

FANUC Series 16*i*/160*i*/160*is*-MODEL B
FANUC Series 18*i*/180*i*/180*is*-MODEL B
FANUC Series 21*i*/210*i*/210*is*-MODEL B
FANUC Series 20*i*-MODEL B

CONNECTION MANUAL (FUNCTION)

- No part of this manual may be reproduced in any form.
- All specifications and designs are subject to change without notice.

The export of this product is subject to the authorization of the government of the country from where the product is exported.

In this manual we have tried as much as possible to describe all the various matters. However, we cannot describe all the matters which must not be done, or which cannot be done, because there are so many possibilities. Therefore, matters which are not especially described as possible in this manual should be regarded as "impossible".

This manual contains the program names or device names of other companies, some of which are registered trademarks of respective owners. However, these names are not followed by ® or ™ in the main body.

Export Control Information

This document and the information contained in this document are classified with an Export Control Classification Number of 2E201. It is restricted and controlled under US export regulations. If you intend to export (or reexport), the document, directly or indirectly, or technical information relating thereto supplied hereunder or any portion thereof, it is your responsibility to ensure compliance with U.S. export control regulations and, if appropriate, to secure any required export licenses in your own name.

DEFINITION OF WARNING, CAUTION, AND NOTE



This manual includes safety precautions for protecting the user and preventing damage to the machine. Precautions are classified into Warning and Caution according to their bearing on safety. Also, supplementary information is described as a Note. Read the Warning, Caution, and Note thoroughly before attempting to use the machine.

WARNING

Applied when there is a danger of the user being injured or when there is a danger of both the user being injured and the equipment being damaged if the approved procedure is not observed.

CAUTION

Applied when there is a danger of the equipment being damaged, if the approved procedure is not observed.

NOTE

The Note is used to indicate supplementary information other than Warning and Caution.

- **Read this manual carefully, and store it in a safe place.**

PREFACE

This manual describes all the NC functions required to enable machine tool builders to design their CNC machine tools. The following items are explained for each function.

1. General

Describes feature of the function. Refer to Operator's manual as required.

2. Signals

Describes names, functions, output conditions and addresses of the signals required to realize a function.

3. Parameters

Describes parameters related with a function.

4. Alarms and messages

Lists the alarms and messages related with a function in a table.

5. Reference item

List the related items of the related manuals in a table.

A list of addresses of all signals and a list of signals are described in the appendix of this manual. Refer to it as required.

Applicable models

The models covered by this manual, and their abbreviations are :

Model name	Abbreviation	
FANUC Series 16i-TB	16i-TB	Series 16i
FANUC Series 16i-MB	16i-MB	
FANUC Series 160i-TB	160i-TB	Series 160i
FANUC Series 160i-MB	160i-MB	
FANUC Series 160is-TB	160is-TB	Series 160is
FANUC Series 160is-MB	160is-MB	
FANUC Series 18i-TB	18i-TB	Series 18i
FANUC Series 18i-MB5	18i-MB5	
FANUC Series 18i-MB	18i-MB	
FANUC Series 180i-TB	180i-TB	Series 180i
FANUC Series 180i-MB5	180i-MB5	
FANUC Series 180i-MB	180i-MB	
FANUC Series 180is-TB	180is-TB	Series 180is
FANUC Series 180is-MB5	180is-MB5	
FANUC Series 180is-MB	180is-MB	
FANUC Series 21i-TB	21i-TB	Series 21i
FANUC Series 21i-MB	21i-MB	
FANUC Series 210i-TB	210i-TB	Series 210i
FANUC Series 210i-MB	210i-MB	
FANUC Series 210is-TB	210is-TB	Series 210is
FANUC Series 210is-MB	210is-MB	
FANUC Series 20i-TB	20i-TB	Series 20i
FANUC Series 20i-FB	20i-FB	

For ease of understanding, the models are categorized as follows:

T series: 16i-TB, 160i-TB, 160is-TB, 18i-TB, 180i-TB, 180is-TB, 21i-TB, 210i-TB, 210is-TB, 20i-TB

M series: 16i-MB, 160i-MB, 160is-MB, 18i-MB5, 180i-MB5, 180is-MB5, 18i-MB, 180i-MB, 180is-MB, 21i-MB, 210i-MB, 210is-MB

F series: 20i-FB

In this manual, the 18i/180i/180is-MB indicates both the 18i/180i/180is-MB5 and 18i/180i/180is-MB unless otherwise specified.

NOTE

- 1 Some functions described in this manual may not be applied to some products.
For details, refer to the DESCRIPTIONS manual (B-63522EN).
- 2 The specifications of each function of the F series are the same as for the M series.
For the F series, read the description for the M series in this manual.

Signal description

Relation of interface signals among the CNC, the PMC and the machine tool is shown below:

[For one-path control]

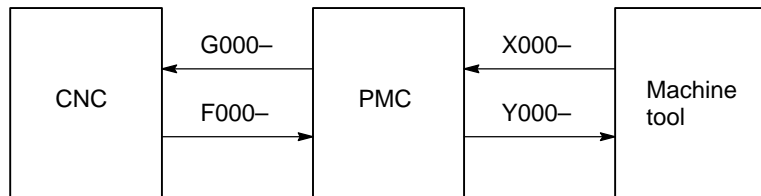

[For two-path control]

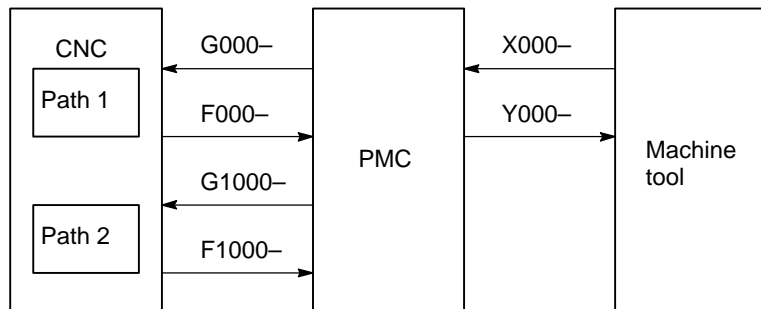

NOTE

- 1 In two-path control, the signals of the same functions are prepared for both of path 1 and path 2. These signals have suffix #1 and #2 to their signal names on path 1 and path 2, respectively.
When a signal is common to both paths, the signal is prepared only to path 1 and the suffix #1 and #2 are not attached.
- 2 In the context, signals are described on path 1 only. Refer to Appendix A.1.2 List of addresses for two-path control for signals on path 2.
- 3 For the signals, a single data number is assigned to 8 bits. Each bit has a different meaning.

● **Expression of signals**

One address accommodates eight signals.

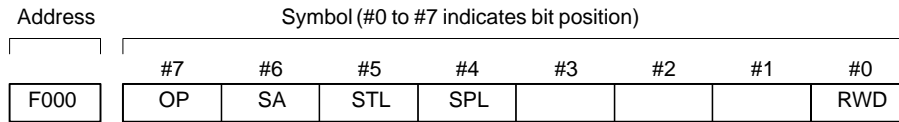

In an item where both T series and M series are described, some signals are covered with shade () in the signal address figure as shown below. This means either T series or M series does not have this signal. Upper part is for T series and lower part is for M series.

[Example 1]

Signal EXLM, ST is a common signal, STLK is for T series only and RLSOT and RVS are for M series only.

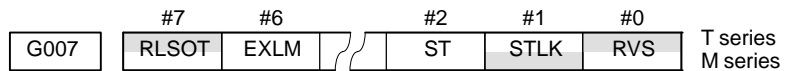

Parameter description

Parameters are classified by data type as follows :

Dta type	Valid data range	Remarks
Bit	0 or 1	
Bit axis		
Byte	-128 to 127 0 to 255	In some parameters, signs are ignored.
Byte axis		
Word	-32768 to 32767 0 to 65535	
Word axis		
2-word	-99999999 to 99999999	
2-word axis		

NOTE

- 1 For the bit type and bit axis type parameters, a single data number is assigned to 8 bits. Each bit has a different meaning.
- 2 The axis type allows data to be set separately for each control axis.
- 3 The valid data range for each data type indicates a general range. The range varies according to the parameters. For the valid data range of a specific parameter, see the explanation of the parameter.

● **Notation of bit type and bit axis type parameters**

Data No.	Data (#0 to #7 indicates bit position)							
	#7	#6	#5	#4	#3	#2	#1	#0
0000			SEQ			INI	ISO	TVC

● **Notation of parameters other than bit type and bit axis type**

Data No.	Data
1023	Servo axis number of a specific axis

NOTE

In an item where both T series and M series are described, parameters having different meanings between the T series and M series and parameters that are valid only for the T or M series are indicated in two levels as shown below. Parameters left blank are unavailable.

[Example 1]

Parameter 5010 has different meanings for the T series and M series.

5010	Tool nose radius compensation . . .	T series
	Cutter compensation C . . .	M series

[Example 2]

DPI is a parameter common to the M and T series, but GSB and GSC are parameters valid only for the T series.

3401	#7	#6	}	#0	T series
	GSC	GSB		DPI	
				DPI	M series

[Example 3]

The following parameter is provided only for the M series.

1450		T series
	F1 digit feed . . .	M series

**Related manuals of
Series 16i/18i/21i/160i/
180i/210i/160is/180is/
210is-MODEL B**

The following table lists the manuals related to Series 16i, Series 18i, Series 21i, Series 160i, Series 180i, Series 210i, Series 160is, Series 180is, Series 210is-MODEL B. This manual is indicated by an asterisk(*).

**Related manuals of
Series 16i/18i/21i/160i/180i/210i/160is/180is/210is MODEL B**

Manual name	Specification number	
DESCRIPTIONS	B-63522EN	
CONNECTION MANUAL (HARDWARE)	B-63523EN	
CONNECTION MANUAL (FUNCTION)	B-63523EN-1	*
Series 16i/18i/160i/180i/160is/180is-TB OPERATOR'S MANUAL	B-63524EN	
Series 16i/160i/160is-MB, Series 18i/180i/180is-MB5, Series 18i/180i/180is-MB OPERATOR'S MANUAL	B-63534EN	
Series 21i/210i/210is-TB OPERATOR'S MANUAL	B-63604EN	
Series 21i/210i/210is-MB OPERATOR'S MANUAL	B-63614EN	
MAINTENANCE MANUAL	B-63525EN	
Series 16i/18i/160i/180i/160is/180is-MODEL B PARAMETER MANUAL	B-63530EN	
Series 21i/210i/210is-MODEL B PARAMETER MANUAL	B-63610EN	
PROGRAMMING MANUAL		
Macro Compiler/Macro Executor PROGRAMMING MANUAL	B-61803E-1	
C Language Executor PROGRAMMING MANUAL	B-62443EN-3	
FAPT MACRO COMPILER (For Personal Computer) PROGRAMMING MANUAL	B-66102E	
CAP (T series)		
FANUC Super CAPi T OPERATOR'S MANUAL	B-63284EN	
FANUC Symbol CAPi T OPERATOR'S MANUAL	B-63304EN	
MANUAL GUIDE For Lathe PROGRAMMING MANUAL	B-63343EN	
MANUAL GUIDE For Lathe OPERATOR'S MANUAL	B-63344EN	
CAP (M series)		
FANUC Super CAPi M OPERATOR'S MANUAL	B-63294EN	
MANUAL GUIDE For Milling PROGRAMMING MANUAL	B-63423EN	
MANUAL GUIDE For Milling OPERATOR'S MANUAL	B-63424EN	
PMC		
PMC Ladder Language PROGRAMMING MANUAL	B-61863E	
PMC C Language PROGRAMMING MANUAL	B-61863E-1	
Network		
I/O Link-II OPERATOR'S MANUAL	B-62714EN	

Manual name	Specification number	
Profibus-DP Board OPERATOR'S MANUAL	B-62924EN	
Ethernet Board/DATA SERVER Board OPERATOR'S MANUAL	B-63354EN	
FAST Ethernet Board/FAST DATA SERVER OPERATOR'S MANUAL	B-63644EN	
DeviceNet Board OPERATOR'S MANUAL	B-63404EN	
PC function		
Screen Display Function OPERATOR'S MANUAL	B-63164EN	

Related manuals of Series 20i-MODEL B

The following table lists the manuals related to Series 20i-MODEL B. This manual is indicated by an asterisk(*).

Related manuals of Series 20i-MODEL B

Manual name	Specification number	
DESCRIPTIONS	B-63522EN	
CONNECTION MANUAL (HARDWARE)	B-64193EN	
CONNECTION MANUAL (FUNCTION)	B-63523EN-1	*
Series 20i-TB OPERATOR'S MANUAL (For Manual Lathes)	B-64194EN	
Series 20i-FB OPERATOR'S MANUAL (For Manual Milling Machine)	B-64204EN	
OPERATOR'S MANUAL (For Manual Lathes)	B-62204E-1	
OPERATOR'S MANUAL (For Manual Milling Machine)	B-62174E-1	
MAINTENANCE MANUAL	B-64195EN	
PARAMETER MANUAL	B-64200EN	
PROGRAMMING MANUAL		
Macro Compiler/Macro Executor PROGRAMMING MANUAL	B-61803E-1	
FANUC MACRO COMPILER (For Personal Computer) PROGRAMMING MANUAL	B-66102E	
PMC		
PMC Ladder Language PROGRAMMING MANUAL	B-61863E	
Network		
FAST Ethernet Board/FAST DATA SERVER OPERATOR'S MANUAL	B-63644EN	

**Related manuals of
SERVO MOTOR α is/ α i/ β is
series**

The following table lists the manuals related to SERVO MOTOR α is/ α i/ β is series

Manual name	Specification number
FANUC AC SERVO MOTOR α is/ α i series DESCRIPTIONS	B-65262EN
FANUC AC SERVO MOTOR β is series DESCRIPTIONS	B-65302EN
FANUC AC SERVO MOTOR α is/ α i/ β is series PARAMETER MANUAL	B-65270EN
FANUC AC SPINDLE MOTOR α i series DESCRIPTIONS	B-65272EN
FANUC AC SPINDLE MOTOR β is series DESCRIPTIONS	B-65312EN
FANUC AC SPINDLE MOTOR α i/ β i series PARAMETER MANUAL	B-65280EN
FANUC SERVO AMPLIFIER α i series DESCRIPTIONS	B-65282EN
FANUC SERVO AMPLIFIER β i series DESCRIPTIONS	B-65322EN
FANUC AC SERVO MOTOR α is/ α i series FANUC AC SPINDLE MOTOR α i series FANUC SERVO AMPLIFIER α i series MAINTENANCE MANUAL	B-65285EN
FANUC AC SERVO MOTOR β is series FANUC AC SPINDLE MOTOR β i series FANUC SERVO AMPLIFIER β i series MAINTENANCE MANUAL	B-65325EN

Related manuals of SERVO MOTOR α series

The following table lists the manuals related to SERVO MOTOR α series

Manual name	Specification number
FANUC AC SERVO MOTOR α series DESCRIPTIONS	B-65142
FANUC AC SERVO MOTOR α series PARAMETER MANUAL	B-65150
FANUC AC SPINDLE MOTOR α series DESCRIPTIONS	B-65152
FANUC AC SPINDLE MOTOR α series PARAMETER MANUAL	B-65160
FANUC SERVO AMPLIFIER α series DESCRIPTIONS	B-65162
FANUC SERVO MOTOR α series MAINTENANCE MANUAL	B-65165

Either of the following servo motors and the corresponding spindle can be connected to the CNC covered in this manual.

- FANUC SERVO MOTOR $\alpha is/\alpha i/\beta i$ series
- FANUC SERVO MOTOR α series

This manual mainly assumes that the FANUC SERVO MOTOR αi series of servo motor is used. For servo motor and spindle information, refer to the manuals for the servo motor and spindle that are actually connected.

Table of Contents

DEFINITION OF WARNING, CAUTION, AND NOTE	s-1
PREFACE	p-1
1. AXIS CONTROL	1
1.1 CONTROLLED AXES	2
1.2 SETTING EACH AXIS	5
1.2.1 Name of Axes	5
1.2.2 Increment System	7
1.2.3 Specifying the Rotation Axis	11
1.2.4 Controlled Axes Detach	15
1.2.5 Outputting the Movement State of an Axis	18
1.2.6 Mirror Image	20
1.2.7 Follow-up	23
1.2.8 Servo Off (Mechanical Handle)	25
1.2.9 Position Switch	27
1.2.10 High-Speed Position Switch	32
1.2.11 Direction-Sensitive High-Speed Position Switch	39
1.3 ERROR COMPENSATION	49
1.3.1 Stored Pitch Error Compensation	49
1.3.2 Backlash Compensation	59
1.3.3 Straightness Compensation	61
1.3.4 Gradient Compensation	65
1.3.5 Bidirectional Pitch Error Compensation	68
1.3.6 Extended Bidirectional Pitch Error Compensation	77
1.3.7 Interpolation Type Pitch Error Compensation	79
1.3.8 About Differences among Pitch Error Compensation, Straightness Compensation, and Gradient Compensation (for Reference Purposes)	81
1.3.9 Interpolation type straightness compensation	82
1.4 SETTINGS RELATED TO SERVO-CONTROLLED AXES	90
1.4.1 Parameters Related to Servo	90
1.4.2 Absolute Position Detection	95
1.4.3 FSSB Setting	97
1.4.4 Tentative Absolute Coordinate Setting (M Series)	115
1.5 SETTINGS RELATED WITH COORDINATE SYSTEMS	118
1.5.1 Machine Coordinate System	118
1.5.2 Workpiece Coordinate System/Addition of Workpiece Coordinate System Pair	120
1.5.3 Rotary Axis Roll Over	127
1.5.4 Rotary Table Dynamic Fixture Offset (M Series)	130
1.6 SIMPLE SYNCHRONOUS CONTROL	139
1.7 TANDEM CONTROL	155
1.8 SYNCHRONOUS CONTROL (T SERIES)	164
1.9 SYNCHRONOUS CONTROL AND COMPOSITE CONTROL (T SERIES (TWO-PATH CONTROL))	174
1.9.1 Overview	174
1.9.2 Synchronous Control	177

1.9.3	Composite Control	184
1.9.4	Superimposed Control	187
1.9.5	Signal	189
1.9.6	Parameter	191
1.9.7	Alarms and messages	202
1.9.8	Definition of Warning, Caution, and Note	203
1.9.9	Examples of Applications	210
1.9.10	Troubleshooting	224
1.10	B-AXIS CONTROL (T SERIES)	228
1.11	ANGULAR AXIS CONTROL/ARBITRARY ANGULAR AXIS CONTROL	244
1.12	CHOPPING FUNCTION (M SERIES)	248
1.13	HOBBING FUNCTION (T SERIES)/ FUNCTION FOR HOBBING MACHINE (M SERIES) ...	262
1.14	ELECTRIC GEAR BOX (M SERIES)	279
1.14.1	SIMPLE ELECTRIC GEAR BOX (G80, G81)	279
1.14.2	Spindle Electronic Gear Box (M series)	291
1.14.3	Electronic Gear Box Automatic Phase Synchronization (M Series)	305
1.14.4	Electronic Gear Box 2 Pair (M Series)	315
1.15	FLEXIBLE SYNCHRONIZATION CONTROL (M SERIES)	337
1.16	GENERAL PURPOSE RETRACT	345
2. PREPARATIONS FOR OPERATION		349
2.1	EMERGENCY STOP	350
2.2	CNC READY SIGNAL	353
2.3	OVERTRAVEL CHECK	355
2.3.1	Overtravel Signal	355
2.3.2	Stored Stroke Check 1	358
2.3.3	Stored Stroke Check 2, 3	365
2.3.4	Chuck/Tailstock Barrier (T series)	373
2.3.5	Tool Post Interference Check (T series (Two-path Control))	379
2.3.6	Stroke Limit Check Before Move	384
2.3.7	Rotation Area Interference Check	388
2.4	ALARM SIGNAL	421
2.5	START LOCK/INTERLOCK	423
2.6	MODE SELECTION	429
2.7	PATH SELECTION/DISPLAY OF OPTIONAL PATH NAMES (TWO-PATH CONTROL)	437
2.8	STATUS OUTPUT SIGNAL	439
2.9	VRDY OFF ALARM IGNORE SIGNAL	441
2.10	ABNORMAL LOAD DETECTION	443
2.11	SERVO/SPINDLE MOTOR SPEED DETECTION	454
3. MANUAL OPERATION		460
3.1	JOG FEED/INCREMENTAL FEED	461
3.2	MANUAL HANDLE FEED	470
3.3	MANUAL HANDLE INTERRUPTION	478
3.4	TOOL AXIS DIRECTION HANDLE FEED FUNCTION/ TOOL AXIS DIRECTION HANDLE FEED FUNCTION B (M SERIES)	481
3.4.1	Tool Axis Direction Handle Feed Function	481

3.4.2	Tool Axis Perpendicular Direction Handle Feed Function	486
3.5	MANUAL LINEAR/CIRCULAR INTERPOLATION	492
3.6	HANDLE-SYNCHRONOUS FEED	509
3.7	MANUAL RIGID TAPPING (M SERIES)	515
3.8	MANUAL NUMERIC COMMAND	518
3.9	STOP POSITION SETTING FOR JOG FEED	523
3.10	HANDLE-SYNCHRONOUS FEED (Series 20i)	525
4.	REFERENCE POSITION ESTABLISHMENT	532
4.1	MANUAL REFERENCE POSITION RETURN	533
4.2	SETTING THE REFERENCE POSITION WITHOUT DOGS	546
4.3	REFERENCE POSITION SHIFT	554
4.4	REFERENCE POSITION RETURN	557
4.5	2ND REFERENCE POSITION RETURN/3RD, 4TH REFERENCE POSITION RETURN	560
4.6	FLOATING REFERENCE POSITION RETURN	563
4.7	BUTT-TYPE REFERENCE POSITION SETTING	566
4.8	LINEAR SCALE I/F WITH ABSOLUTE ADDRESS REFERENCED MARK (A/B PHASE)/ LINEAR SCALE WITH DISTANCE-CODED REFERENCE MARKS (SERIAL)	573
4.9	EXTENDED FUNCTION OF THE LINEAR SCALE WITH ABSOLUTE ADDRESSING REFERENCE MARKS	593
5.	AUTOMATIC OPERATION	601
5.1	CYCLE START/FEED HOLD	602
5.2	RESET AND REWIND	607
5.3	TESTING A PROGRAM	612
5.3.1	Machine Lock	612
5.3.2	Dry Run	615
5.3.3	Single Block	618
5.3.4	Manual Handle Retrace (T Series)	621
5.4	MANUAL ABSOLUTE ON/OFF	636
5.5	OPTIONAL BLOCK SKIP/ADDITION OF OPTIONAL BLOCK SKIP	639
5.6	SEQUENCE NUMBER COMPARISON AND STOP	643
5.7	PROGRAM RESTART	644
5.8	TOOL RETRACTION AND RETURN	647
5.9	EXACT STOP/EXACT STOP MODE/TAPPING MODE/CUTTING MODE (M SERIES)	651
5.10	BALANCE CUT (2-PATH CONTROL FOR T SERIES)	653
5.11	DNC OPERATION	655
5.12	MANUAL INTERVENTION AND RETURN	658
5.13	RETRACTION FOR RIGID TAPPING (M SERIES)	659
6.	INTERPOLATION FUNCTION	666
6.1	POSITIONING	667
6.2	LINEAR INTERPOLATION	670
6.3	CIRCULAR INTERPOLATION	673
6.4	THREAD CUTTING	680
6.4.1	Thread Cutting	680
6.4.2	Thread Cutting Cycle Retract (T series)	687

6.5	SINGLE DIRECTION POSITIONING	689
6.6	HELICAL INTERPOLATION	696
6.7	INVOLUTE INTERPOLATION (M SERIES)	698
6.8	POLAR COORDINATE INTERPOLATION	701
6.9	CYLINDRICAL INTERPOLATION	704
6.10	CYLINDRICAL INTERPOLATION CUTTING POINT COMPENSATION (M SERIES)	707
6.11	POLYGONAL TURNING (T SERIES)	712
6.11.1	Polygonal Turning	713
6.11.2	Polygonal Turning with Two Spindles	718
6.12	NORMAL DIRECTION CONTROL (M SERIES)	736
6.13	EXPONENTIAL INTERPOLATION (M SERIES)	742
6.14	SMOOTH INTERPOLATION (M SERIES)	744
6.15	HYPOTHETICAL AXIS INTERPOLATION	746
6.16	HELICAL INTERPOLATION B (M SERIES)	747
6.17	SPIRAL INTERPOLATION, CONICAL INTERPOLATION (M SERIES)	748
6.18	NURBS INTERPOLATION (M SERIES)	751
6.19	LINEAR INTERPOLATION (G28, G30, G53)	753
6.20	THREE-DIMENSIONAL CIRCULAR INTERPOLATION (M SERIES)	755

7. FEEDRATE CONTROL/ACCELERATION AND DECELERATION CONTROL 757

7.1	FEEDRATE CONTROL	758
7.1.1	Rapid Traverse Rate	758
7.1.2	Cutting Feedrate Clamp	761
7.1.3	Feed Per Minute	763
7.1.4	Feed Per Revolution/Manual Feed Per Revolution	766
7.1.5	One-digit F Code Feed (M series)	768
7.1.6	Feedrate Inverse Time Specification (M series)	771
7.1.7	Override	772
7.1.7.1	Rapid traverse override	772
7.1.7.2	Feedrate override	775
7.1.7.3	Second feedrate override	778
7.1.7.4	Override cancel	779
7.1.8	Automatic Corner Override (M series)	780
7.1.9	External Deceleration	784
7.1.10	Feed Stop Function	786
7.1.11	Feedrate Clamping by Arc Radius (M series)	787
7.1.12	Automatic Corner Deceleration	790
7.1.13	Advanced Preview Control	798
7.1.14	High-precision Contour Control by RISC (M series)	810
7.1.14.1	Look-ahead acceleration/deceleration before interpolation	813
7.1.14.2	Automatic feedrate control function	826
7.1.14.3	Signal	836
7.1.14.4	Parameter	837
7.1.14.5	Alarm and message	849
7.1.14.6	Note	850
7.1.14.7	Reference item	851
7.1.15	Positioning by Optimal Acceleration	852

7.1.16	AI Contour Control/AI Nano Contour Control (M series)	856
7.1.17	AI Advanced Preview Control (M Series)	895
7.1.18	AI High-precision Contour Control/AI Nano High-precision Contour Control (M Series) ..	897
7.1.18.1	Look-ahead acceleration/deceleration before interpolation	899
7.1.18.2	Feedrate control method	905
7.1.19	RISC Processor Operation (AI High-precision Contour Control/ AI Nano High-precision Contour Control/Tool Length Compensation Along the Tool Axis/ Three-dimensional Cutter Compensation/Tool tip Control/ Three-dimensional Circular Interpolation) (M Series)	922
7.1.20	High-speed Linear Interpolation (M series)	934
7.1.21	Look-ahead Bell-Shaped Acceleration/Deceleration Before Interpolation Time Constant Change Function (M Series)	937
7.2	ACCELERATION/DECELERATION CONTROL	943
7.2.1	Automatic Acceleration/Deceleration	943
7.2.1.1	Automatic acceleration/deceleration	943
7.2.1.2	Rapid traverse block overlap	947
7.2.2	Rapid Traverse Bell-shaped Acceleration/Deceleration	949
7.2.3	Linear Acceleration/Deceleration after Cutting Feed Interpolation	952
7.2.4	Bell-Shaped Acceleration/Deceleration after Cutting Feed Interpolation	956
7.2.5	Linear Acceleration/Deceleration before Cutting Feed Interpolation	959
7.2.6	Corner Control	965
7.2.6.1	In-position check	965
7.2.6.2	In-position check independently of feed/rapid traverse	967
7.2.6.3	Error detect (T series)	969
7.2.7	Feed Forward in Rapid Traverse	970
8.	AUXILIARY FUNCTION	971
8.1	MISCELLANEOUS FUNCTION/2ND AUXILIARY FUNCTION	972
8.2	AUXILIARY FUNCTION LOCK	985
8.3	MULTIPLE M COMMANDS IN A SINGLE BLOCK	987
8.4	HIGH-SPEED M/S/T/B INTERFACE	991
8.5	WAITING M CODE (TWO-PATH CONTROL)	995
8.6	M CODE GROUP CHECK FUNCTION	997
9.	SPINDLE SPEED FUNCTION	1001
9.1	SPINDLE SPEED FUNCTION (S CODE OUTPUT)	1002
9.2	SPINDLE SERIAL OUTPUT/SPINDLE ANALOG OUTPUT	1003
9.3	SPINDLE SPEED CONTROL	1011
9.4	SPINDLE SPEED CONTROL FOR TWO-PATH LATHE	1040
9.5	CONSTANT SURFACE SPEED CONTROL	1052
9.6	SPINDLE SPEED FLUCTUATION DETECTION	1059
9.7	ACTUAL SPINDLE SPEED OUTPUT (T SERIES)	1064
9.8	SPINDLE POSITIONING (T SERIES)	1065
9.9	Cs CONTOUR CONTROL	1086
9.9.1	Cs Contour Control	1086
9.9.2	Cs Axis Coordinate Setup Function	1101
9.10	MULTI-SPINDLE CONTROL	1109

9.11	RIGID TAPPING	1126
9.11.1	General	1126
9.11.2	Connection Among Spindle, Spindle Motor, and Position Coder	1128
9.11.3	Rigid Tapping Specification	1133
9.11.4	Display Data on the Diagnosis Screen	1134
9.11.5	Command Format	1138
9.11.6	Signal	1142
9.11.6.1	Signals for the rigid tapping function	1142
9.11.6.2	Signals related to S code output	1143
9.11.6.3	Signals related to gear switching	1144
9.11.6.4	Signals related to second spindle/third spindle rigid tapping	1146
9.11.6.5	Signal addresses	1148
9.11.6.6	Notes on interface with the PMC	1148
9.11.7	Timing Charts for Rigid Tapping Specification	1151
9.11.7.1	When M29 is specified before G84 (G74)	1152
9.11.7.2	M29 and G84 (G74) are specified in the same block	1156
9.11.7.3	Specifying G84 (G74) for rigid tapping by parameters	1160
9.11.7.4	Timing to cancel rigid tapping mode	1164
9.11.8	Parameter	1166
9.11.9	Alarm and Message	1192
9.11.10	Notes	1194
9.11.11	Rigid-Tapping Bell-Shaped Acceleration/ Deceleration (M Series)	1198
9.11.12	Reference Item	1202
9.12	SPINDLE SYNCHRONOUS CONTROL	1203
9.13	SPINDLE ORIENTATION	1207
9.14	SPINDLE OUTPUT SWITCHING	1211
9.15	THREE/FOUR-SPINDLE SERIAL OUTPUT	1213
9.16	SIMPLE SPINDLE SYNCHRONOUS CONTROL	1225
9.17	READY SIGNALS FOR SERIAL SPINDLE OPERATION	1237
10.	TOOL FUNCTIONS	1239
10.1	TOOL FUNCTION	1240
10.2	TOOL COMPENSATION VALUE/TOOL COMPENSATION NUMBER/ TOOL COMPENSATION MEMORY	1243
10.2.1	Tool Compensation Value/Tool Compensation Number/Tool Compensation Memory	1243
10.2.2	Tool Offset Pairs (400 Pairs) and Tool Offset Pairs (999 Pairs) (T Series)	1251
10.3	TOOL LIFE MANAGEMENT	1259
10.3.1	Tool life management	1259
10.3.2	Tool Life Management B (M Series)	1268
10.3.3	Tool Life Arrival Notice Signal (M Series)	1268
10.4	CUTTER COMPENSATION	1270
10.4.1	Cutter Compensation B, C (M Series)	1270
10.4.2	Tool Nose Radius Compensation (T Series)	1276
10.4.3	Tool Axis Direction Tool Length Compensation (M Series)	1280
10.4.3.1	Tool axis direction tool length compensation	1280
10.4.3.2	Control point compensation of tool length compensation along tool axis	1285
10.4.4	Three-dimensional Cutter Compensation (M series)	1296

10.4.5	Tool Center Point Control (M series)	1306
11.	PROGRAM COMMAND	1321
11.1	DECIMAL POINT PROGRAMMING/ POCKET CALCULATOR TYPE DECIMAL POINT PROGRAMMING	1322
11.2	G CODE SYSTEM (T SERIES)	1325
11.3	PROGRAM CONFIGURATION	1331
11.4	INCH/METRIC CONVERSION	1334
11.5	HIGH SPEED CYCLE CUTTING	1339
11.6	CUSTOM MACRO	1346
11.6.1	Custom Macro	1346
11.6.2	Interruption Type Custom Macro	1358
11.6.3	Custom Macro Variables Common to Two-path Control (Two-path Control)	1361
11.6.4	Embedded Macro	1363
11.6.5	Embedded macro for milling (M series)	1376
11.6.6	Embedded Measurement Macros (M Series)	1422
11.7	CANNED CYCLE (M SERIES)/CANNED CYCLE FOR DRILLING (T SERIES)	1453
11.8	EXTERNAL MOTION FUNCTION (M SERIES)	1464
11.9	CANNED CYCLE (T SERIES)/MULTIPLE REPETITIVE CANNED CYCLE (T SERIES)	1466
11.10	MIRROR IMAGE FOR DOUBLE TURRETS (T SERIES)	1474
11.11	INDEX TABLE INDEXING FUNCTION (M SERIES)	1476
11.12	SCALING (M SERIES)	1485
11.13	COORDINATE SYSTEM ROTATION	1489
11.14	THREE-DIMENSIONAL COORDINATE CONVERSION	1492
11.15	RETRACE (M SERIES)	1495
11.16	MACRO COMPILER/ EXECUTER	1499
11.17	SMALL HOLE PECK DRILLING CYCLE (M SERIES)	1500
11.18	HIGH-SPEED CYCLE MACHINING RETRACTING	1507
11.19	HIGH-SPEED CYCLE MACHINING SKIP FUNCTION	1514
12.	DISPLAY/SET/EDIT	1519
12.1	DISPLAY/SET	1520
12.1.1	Clock Function	1520
12.1.2	Displaying Operation History	1521
12.1.3	Help Function	1526
12.1.4	Displaying Alarm History	1527
12.1.5	Servo Tuning Screen	1528
12.1.6	Spindle Setting and Tuning Screen	1528
12.1.7	Waveform Diagnosis Display	1529
12.1.8	Self-diagnosis	1531
12.1.9	Display of Hardware and Software Configuration	1532
12.1.10	Position Display Neglect	1533
12.1.11	Run Hour and Parts Count Display	1534
12.1.12	Graphic Display/Dynamic Graphic Display/Background Graphic	1540
12.1.13	Displaying Operating Monitor	1549
12.1.14	Stamping the Machining Time	1551
12.1.15	Software Operator's Panel	1552

12.1.16	Multi-language Display	1563
12.1.17	Remote Diagnosis	1564
12.1.18	External Operator Message Logging and Display	1566
12.1.19	Erase Screen Display/Automatic Erase Screen Display	1568
12.1.20	Touch Panel	1571
12.1.21	External Touch Panel Interface	1575
12.1.22	Periodic Maintenance Screen	1578
12.1.23	Fine Torque Sensing	1588
12.1.24	Actual Speed Display	1605
12.1.25	Parameter Set Supporting Screen	1606
12.1.26	Machining Condition Selecting	1614
12.1.27	Other Functions	1628
12.1.28	FANUC Two-Byte Character Code Table	1629
12.2	EDIT	1635
12.2.1	Part Program Storage Length	1635
12.2.2	No. of Registered Programs	1636
12.2.3	Memory Protection Key	1637
12.2.4	Password Function	1640
12.2.5	Background Editing	1643
12.2.6	Playback	1644
12.2.7	Conversational Programming with Graphic Function	1645
12.2.8	Program Copy between Two Paths	1645
12.3	ENCRYPTING PROGRAMS	1648
13.	INPUT/OUTPUT OF DATA	1655
13.1	READER/PUNCHER INTERFACE	1656
13.2	REMOTE BUFFER	1670
13.3	DNC1 INTERFACE	1671
13.4	DNC2 INTERFACE	1680
13.5	EXTERNAL I/O DEVICE CONTROL	1681
13.6	SIMULTANEOUS INPUT AND OUTPUT OPERATIONS (M SERIES)	1689
13.7	EXTERNAL PROGRAM INPUT	1692
13.8	DATA INPUT/OUTPUT FUNCTIONS BASED ON THE I/O Link	1697
13.9	SCREEN HARD COPY FUNCTION	1721
14.	MEASUREMENT	1728
14.1	TOOL LENGTH MEASUREMENT (M SERIES)	1729
14.2	AUTOMATIC TOOL LENGTH MEASUREMENT (M SERIES)/ AUTOMATIC TOOL OFFSET (T SERIES)	1730
14.3	SKIP FUNCTION	1737
14.3.1	Skip Function	1737
14.3.2	High-speed Skip Signal	1740
14.3.3	Multi-step Skip	1744
14.3.4	Torque Limit Skip	1748
14.3.5	Continuous High-speed Skip Function (M series)	1751
14.3.6	Skip Function for EGB Axis (M series)	1754
14.4	ENTERING COMPENSATION VALUES	1758

14.4.1	Input of Offset Value Measured A (T series)	1758
14.4.2	Input of Tool Offset Value Measured B (T series)	1760
14.4.3	Input of Measured Workpiece Origin Offsets	1780
14.5	TOOL LENGTH/WORKPIECE ORIGIN MEASUREMENT B (M SERIES)	1781
15.	PMC CONTROL FUNCTION	1785
15.1	PMC AXIS CONTROL	1786
15.1.1	PMC Axis Control	1786
15.1.2	PMC Axis Control Expansion	1833
15.1.3	Constant Velocity Command Position Control	1837
15.2	EXTERNAL DATA INPUT	1839
15.3	EXTERNAL WORKPIECE NUMBER SEARCH	1851
15.3.1	External Workpiece Number Search	1851
15.3.2	Expanded External Workpiece Number Search	1854
15.4	SPINDLE OUTPUT CONTROL BY THE PMC	1856
15.5	EXTERNAL KEY INPUT	1864
15.6	DIRECT OPERATION BY PMC OR OPEN CNC	1870
15.6.1	DNC Operation by the PMC or OPEN CNC (PC with HSSB Connection)	1870
15.6.2	DNC Operation by a PC Connected to the HSSB PORT2	1871
15.7	ONE TOUCH MACRO CALL	1872
16.	INTERFACE WITH THE POWER MATE CNC	1879
16.1	FANUC SERVO MOTOR β SERIES I/O LINK OPTION MANUAL HANDLE INTERFACE (PERIPHERAL DEVICE CONTROL)	1880
17.	EMBEDDED ETHERNET FUNCTION	1888
17.1	EMBEDDED ETHERNET AND PCMCIA ETHERNET	1889
17.2	LIST OF FUNCTIONS	1890
17.2.1	FACTOLINK Function	1890
17.2.2	FOCAS1/Ethernet Function	1891
17.2.3	DNC1/Ethernet Function	1892
17.2.4	FTP File Transfer Function	1894
17.2.5	Functional Differences between the Embedded Ethernet Function and the Ethernet Function Based on the Option Board	1894
17.3	SETTING THE EMBEDDED ETHERNET FUNCTION	1896
17.3.1	Parameter Setting of the FACTOLINK Function	1896
17.3.1.1	Notes on using the FACTOLINK function for the first time	1896
17.3.1.2	FACTOLINK parameter setting screen	1897
17.3.1.3	Parameters	1900
17.3.1.4	Using the FACTOLINK function on a small network	1902
17.3.1.5	Configuring a large network	1903
17.3.2	Parameter Setting of the FOCAS1/Ethernet Function	1903
17.3.2.1	Notes on using the FOCAS1/Ethernet function for the first time	1903
17.3.2.2	FOCAS1/Ethernet parameter setting screen	1904
17.3.2.3	Using the FOCAS1/Ethernet function on a small network	1908
17.3.2.4	Using the DNC1/Ethernet function on a small network	1909
17.3.2.5	Configuring a large network	1910

17.3.3	Parameter Setting of the FTP File Transfer Function	1910
17.3.3.1	Notes on using the FTP file transfer function for the first time	1910
17.3.3.2	FTP file transfer parameter setting screen	1911
17.3.3.3	Parameters	1914
17.3.3.4	Using the FTP file transfer function on a small network	1915
17.3.3.5	Configuring a large network	1916
17.3.4	Communication Parameter Input Method	1916
17.4	SWITCHING BETWEEN THE EMBEDDED ETHERNET DEVICES	1924
17.5	EMBEDDED ETHERNET OPERATIONS	1926
17.5.1	FACTOLINK Function	1926
17.5.2	FTP File Transfer Function	1927
17.5.2.1	Host file list display	1927
17.5.2.2	Host file search	1930
17.5.2.3	Host file deletion	1930
17.5.2.4	NC program input	1931
17.5.2.5	NC program output	1932
17.5.2.6	Input/output of various types of data	1934
17.5.2.7	Checking and changing of the connection host	1940
17.6	EMBEDDED ETHERNET ERROR MESSAGE SCREEN	1942
17.7	EMBEDDED ETHERNET MAINTENANCE SCREEN	1944
17.8	DHCP/DNS FUNCTIONS	1950
17.8.1	Overview	1950
17.8.2	Settings	1952
17.8.2.1	Parameters	1952
17.8.2.2	Ethernet parameter screen	1953
17.8.3	Application functions which can use DHCP/DNS	1955
17.8.3.1	Applications which can utilize DHCP function	1955
17.8.3.2	Application which can utilize DNS function	1955
17.8.4	Example of settings	1956
17.8.4.1	Example of DHCP server settings on Windows2000 server	1957
17.8.4.2	Example of DNS server settings on Windows2000 Server	1965
17.8.5	Application of DHCP and DNS to FOCAS1/Ethernet function	1972
17.8.5.1	Flow of action	1972
17.8.5.2	Setting of a PC	1973
17.8.5.3	Settings of CNC	1973
17.9	TROUBLESHOOTING	1974
17.9.1	Check Items Related to Connection with the Hub	1974
17.9.2	Check Items Related to Connection with a Backbone	1974
17.9.3	Checking the Setting of Each Parameter	1975
17.9.4	Checking Communication	1976
17.10	ERROR MESSAGES	1979
17.10.1	EMB_ETH MASTER CTRL LOG Screen	1979
17.10.2	EMB_ETH FOCAS1/ETHER LOG Screen	1980
17.10.3	EMB_ETH FTP TRANSFER LOG Screen	1980
17.10.4	EMB_ETH FACTOLINK LOG Screen	1980
17.11	GLOSSARY FOR ETHERNET	1981
18.	TROUBLE DIAGNOSIS	1983
18.1	TROUBLE DIAGNOSIS	1984

18.1.1	Outline	1984
18.1.2	Trouble Diagnosis Guidance Screen	1986
18.1.3	Trouble Diagnosis Monitor Screen	1988
18.1.4	Trouble Diagnosis Parameter Screen	1992
18.1.5	Trouble Diagnosis Graphic Screen	1994
18.1.6	Trouble Forecast Level Setting Screen (Only for Servo Axis)	1996
18.2	MACHINE ALARM DIAGNOSIS	1999
18.2.1	Outline	1999
18.2.2	Making Guidance Tables	2000
18.3	α i SERVO WARNING INTERFACE	2008
18.4	WARNING INTERFACE FOR THE α i SPINDLE	2010
19.	INTERFACES RELATED TO Series 20i MACRO	2012
19.1	SIGNALS USED BY MACHINING GUIDANCE FUNCTION (20i-F/T)	2013
19.2	SIGNALS USED FOR POLYGON LIMIT MACHINING (20i-F)	2026
 APPENDIX		
A.	INTERFACE BETWEEN CNC AND PMC	2031
A.1	LIST OF ADDRESSES	2032
A.1.1	Series 16i/18i/160i/180i/160is/180is List of Addresses (One-path Control)	2032
A.1.2	Series 16i/18i/160i/180i/160is/180is List of Addresses (Two-path Control)	2060
A.1.3	Series 21i/210i/210is Address List	2114
A.1.4	Series 20i Address List	2142
A.2	SIGNAL SUMMARY	2161
A.2.1	Signal Summary (In Order of Functions)	2161
A.2.2	List of Signals (In Order of Symbols)	2184
A.2.3	List of Signals (In Order of Addresses)	2204

1

AXIS CONTROL



1.1 CONTROLLED AXES

General

Series 16*i*, Series 160*i*, Series 160*is*

Item		M series	T series
No. of basic controlled axes	1-path	3 axes	2 axes
	2-path	3 axes per path	2 axes per path
Controlled axes expansion (total)	1-path	Max. 8 axes (Including the Cs axis)	Max. 8 axes (Including the Cs axis)
	2-path	Max. 8 axes per path (Including the Cs axis)	At 2 CPUs with 2-path control Max. 8 axes per path (Including the Cs axis) At 1 CPU with 2-path control Max. 4 axes per path (Including the Cs axis)
Basic simultaneously controlled axes	1-path	2 axes	2 axes
	2-path	2 axes per path	2 axes per path
Simultaneously controlled axes expansion (total)	1-path	Max. 6 axes	Max. 6 axes
	2-path	Max. 6 axes per path	Max. 6 axes per path (Max. 4 axes per path at 1 CPU with 2-path control)

Series 18*i*, Series 180*i*, Series 180*is*

Item		M series		T series
		MB5	MB	
No. of basic controlled axes	1-path	3 axes		2 axes
	2-path	—		2 axes per path
Controlled axes expansion (total)	1-path	Max. 8 axes (Including the Cs axis)		Max. 8 axes (Including the Cs axis)
	2-path	—		At 2 CPUs with 2-path control Max. 8 axes per path (Including the Cs axis) At 1 CPU with 2-path control Max. 4 axes per path (Including the Cs axis)
Basic simultaneously controlled axes	1-path	2 axes		2 axes
	2-path	—		2 axes per path
Simultaneously controlled axes expansion (total)	1-path	Max. 5 axes	Max. 4 axes	Max. 4 axes
	2-path	—		Max. 4 axes per path

**Series 21i, Series 210i,
Series 210is**

Item		M series	T series
No. of basic controlled axes	1-path	3 axes	2 axes
Controlled axes expansion (total)	1-path	Max. 5 axes (Including the Cs axis)	Max. 5 axes (Including the Cs axis)
Basic simultaneously controlled axes	1-path	2 axes	2 axes
Simultaneously controlled axes expansion (total)	1-path	Max. 4 axes	Max. 4 axes

Series 20i

Item		F series	M series
Number of basic controlled axes	One path	Three axes	Two axes
Total number of controlled axes including extensions	One path	Up to four axes	Up to two axes
Number of basic simultaneously controlled axes	One path	Three axes	Two axes
Total number of simultaneously controlled axes including extensions	One path	Up to four axes	Up to two axes

Parameter

1010	Number of CNC-controlled axes
------	-------------------------------

NOTE

After setting this parameter, turn the power off then on again so that the setting will take effect.

[Data type] Byte

[Valid data range] 1, 2, 3, ..., the number of controlled axes

Set the maximum number of axes that can be controlled by the CNC.

[Example] Suppose that the first axis is the X axis, and the second and subsequent axes are the Y, Z, A, B, and C axes in that order, and that they are controlled as follows:

X, Y, Z, and A axes: Controlled by the CNC and PMC

B and C axes: Controlled by the PMC (cannot be controlled directly by the CNC)

Then set this parameter to 4 (total 4: X, Y, Z, and A)

Alarm and message

Number	Message	Description
015	TOO MANY AXES COMMANDED (M series)	The number of the commanded axes exceeded that of simultaneously controlled axes. Correct the program.
	TOO MANY AXES COMMANDED (T series)	An attempt was made to move the machine along the axes, but the number of the axes exceeded the specified number of axes controlled simultaneously. Alternatively, in a block where the skip function activated by the torque-limit reached signal (G31 P99/P98) was specified, either moving the machine along an axis was not specified, or moving the machine along multiple axes was specified. Specify movement only along one axis.

Note

NOTE

When the seven-soft key type display unit is used, the overall position display screen and the position display screen for manual handle interrupt can display up to eight axes. The positions of the 9th and 10th axes are not displayed on these screens when used with 2-path control having nine or more axes.

Reference item

Series 16i/18i/160i/180i/ 160is/180is	OPERATOR'S MANUAL (For Machining Center) (B-63534EN)	II.2.1	Controlled Axes
	OPERATOR'S MANUAL (For Lathe) (B-63524EN)	II.2.1	Controlled Axes
Series 21i/210i/210is	OPERATOR'S MANUAL (For Machining Center) (B-63614EN)	II.2.1	Controlled Axes
	OPERATOR'S MANUAL (For Lathe) (B-63604EN)	II.2.1	Controlled Axes
Series 20i	OPERATOR'S MANUAL (For Manual Milling Machine) (B-64204EN)	II.2.1	Controlled Axes
	OPERATOR'S MANUAL (For Manual Lathes) (B-64194EN)	II.2.1	Controlled Axes

1.2 SETTING EACH AXIS

1.2.1 Name of Axes

General

Each axis that is controlled by the CNC (including those controlled by the PMC) must be named. Select and set names from among X, Y, Z, A, B, C, U, V, and W (with parameter 1020).

The names of the basic axes, however, are fixed (X, Y, and Z for the M series and X and Z for the T series). The names of additional axes can be selected, as desired, from the names other than those for the basic axes. The same name cannot be assigned to more than one axis.

With 2-path control, the name of the basic axis for one path is fixed. The names of additional axes can be optionally selected from axes names, except axes names of basic axes by using parameter No. 1020. For one path, the same axis name cannot be assigned to multiple axes, but the same axis name can be used with the other path.

Parameter

1020	Name of the axis used for programming for each axis
------	---

[Data type] Byte axis

Set the name of the program axis for each control axis, with one of the values listed in the following table:

Axis name	Setting	Axis name	Setting	Axis name	Setting	Axis name	Setting
X	88	U	85	A	65	E	69
Y	89	V	86	B	66		
Z	90	W	87	C	67		

NOTE

- 1 With the T series, when G code system A is used, neither U, V, nor W can be used as an axis name. Only when G code system B or C is used, U, V, and W can be used as axis names.
- 2 The same axis name cannot be assigned to more than one axis.
- 3 When the secondary auxiliary function (option) is provided, the address used by the secondary auxiliary function (address B with the T series or, with the M series, the address specified in parameter No.3460) cannot be used as an axis name.
- 4 With the T series, when address C or A is used for chamfering, corner rounding, or direct drawing dimension programming (when the CCR parameter (bit 4 of parameter No.3405) is set to 1), addresses C or A cannot be used as an axis name.
- 5 Only with the T series, address E can be used as an axis name. Address E cannot be used with the M series. When address E is used as an axis name, note the following:
 - When G code system A is used, address E is always assigned to an absolute command.
 - When an equal-lead threading command (G32) is issued in the Series 15 command lead. Use address F to specify the thread lead.

Note**NOTE**

With 2-path control, when information (such as the current position) about each axis is displayed on the screen, an axis name may be followed by a subscript to indicate a path number (e.g., X1 and X2). This is an axis name to help the user to easily understand which path an axis belongs to. When writing a program, the user must specify X, Y, Z, U, V, W, A, B, and C without using a subscript.

Reference item

Series 16 <i>i</i> /18 <i>i</i> /160 <i>i</i> /180 <i>i</i> / 160 <i>is</i> /180 <i>is</i>	OPERATOR'S MANUAL (For Machining Center) (B-63534EN)	II.2.2	NAMES OF AXES
	OPERATOR'S MANUAL (For Lathe) (B-63524EN)	II.2.2	NAMES OF AXES
Series 21 <i>i</i> /210 <i>i</i> /210 <i>is</i>	OPERATOR'S MANUAL (For Machining Center) (B-63614EN)	II.2.2	NAMES OF AXES
	OPERATOR'S MANUAL (For Lathe) (B-63604EN)	II.2.2	NAMES OF AXES
Series 20 <i>i</i>	OPERATOR'S MANUAL (For Manual Milling Machine) (B-64204EN)	II.2.2	NAME OF AXES
	OPERATOR'S MANUAL (For Manual Lathes) (B-64194EN)	II.2.2	NAME OF AXES

1.2.2 Increment System

General

The increment system consists of the least input increment (for input) and least command increment (for output). The least input increment is the least increment for programming the travel distance. The least command increment is the least increment for moving the tool on the machine. Both increments are represented in mm, inches, or degrees.

The increment system is classified as either IS-B or IS-C (Tables 1.2.2(a) and 1.2.2 (b)). Select IS-B or IS-C using bit 1 (ISC) of parameter 1004. When selecting IS-C, the option of increment system 1/10 is necessary.

Table 1.2.2 (a) Increment system IS-B

		Least input increment	Least command increment
Metric system machine	mm input	0.001mm(Diameter)	0.0005mm
		0.001mm(Radius)	0.001mm
		0.001deg	0.001deg
	inch input	0.0001inch(Diameter)	0.0005mm
		0.0001inch(Radius)	0.001mm
		0.001deg	0.001deg
Inch system machine	mm input	0.001mm(Diameter)	0.00005inch
		0.001mm(Radius)	0.0001inch
		0.001deg	0.001deg
	inch input	0.0001inch(Diameter)	0.00005inch
		0.0001inch(Radius)	0.0001inch
		0.001deg	0.001deg

Table 1.2.2 (b) Increment system IS-C

		Least input increment	Least command increment
Metric system machine	mm input	0.0001mm(Diameter)	0.00005mm
		0.0001mm(Radius)	0.0001mm
		0.0001deg	0.0001deg
	inch input	0.00001inch(Diameter)	0.00005mm
		0.00001inch(Radius)	0.0001mm
		0.0001deg	0.0001deg
Inch system machine	mm input	0.0001mm(Diameter)	0.000005inch
		0.0001mm(Radius)	0.00001inch
		0.0001deg	0.0001deg
	inch input	0.00001inch(Diameter)	0.000005inch
		0.00001inch(Radius)	0.00001inch
		0.0001deg	0.0001deg

NOTE

Diameter programming is used only for T series. Diameter programming or radius programming is determined by parameter DIAx (No. 1006#3) for each axis. Also, parameter IPR (No. 1004#7) can make the least input increment of IS-B and IS-C ten times the least command increment on each axis.

Parameter

	#7	#6	#5	#4	#3	#2	#1	#0
0000						INI		

The following parameter can be set at “Setting screen”.

[Data type] Bit

INI Unit of input

0 : In mm

1 : In inches

	#7	#6	#5	#4	#3	#2	#1	#0
1001								INM

NOTE

When this parameter is set, the power must be turned off before operation is continued.

[Data type] Bit

INM Least command increment on the linear axis

0 : In mm (metric system machine)

1 : In inches (inch system machine)

1004	#7	#6	#5	#4	#3	#2	#1	#0
	IPR						ISC	
	IPR						ISC	ISA

NOTE

After setting this parameter, turn the power off then on again so that the setting will take effect.

[Data type] Bit

ISA, ISC The least input increment and least command increment are set.

ISC	ISA	Least input increment and least command increment	Symbol
0	0	0.001mm, 0.001deg, or 0.0001inch	IS-B
0	1	0.01mm, 0.01deg, or 0.001inch	IS-A
1	0	0.0001mm, 0.0001deg, or 0.00001inch	IS-C

NOTE

IS-A is not available.

IPR Whether the least input increment for each axis is set to a value 10 times as large as the least command increment is specified, in increment systems of IS-B and IS-C, mm input.

0 : The least input increment is not set to a value 10 times as large as the least command increment.

1 : The least input increment is set to a value 10 times as large as the least command increment.

If IPR is set to 1, the least input increment is set as follows:

Input increment	Least input increment
IS-B	0.01 mm, 0.01 deg, or 0.0001 inch
IS-C	0.001 mm, 0.001 deg, or 0.00001 inch

NOTE

For IS-A, the least input increment cannot be set to a value 10 times as large as the least command increment. When inch of input is specified, the least input increment does not become 10 times as large as the least command increment.

1006	#7	#6	#5	#4	#3	#2	#1	#0
					DIAx			

NOTE
 When this parameter is changed, turn off the power before continuing operation.

[Data type] Bit axis

DIAx Either a diameter or radius is set to be used for specifying the amount of travel on each axis.

- 0 : Radius
- 1 : Diameter

Reference item

Series 16i/18i/160i/180i/ 160is/180is	OPERATOR'S MANUAL (For Machining Center) (B-63534EN)	II.2.3	Increment System
	OPERATOR'S MANUAL (For Lathe) (B-63524EN)	II.2.3	Increment System
Series 21i/210i/210is	OPERATOR'S MANUAL (For Machining Center) (B-63614EN)	II.2.3	Increment System
	OPERATOR'S MANUAL (For Lathe) (B-63604EN)	II.2.3	Increment System
Series 20i	OPERATOR'S MANUAL (For Manual Milling Machine) (B-64204EN)	II.2.3	Increment System
	OPERATOR'S MANUAL (For Manual Lathes) (B-64194EN)	II.2.3	Increment System

1.2.3 Specifying the Rotation Axis

General

Bit 0 (ROT_x) of parameter 1006 can be used to set each axis to a linear axis or rotation axis. Bit 1 (ROS_x) of parameter 1006 can be used to select the rotation axis type, A or B, for each axis. See the explanation of the parameters for details of types A and B.

When the roll over function is used, the values displayed for absolute coordinates are rounded by the shift amount per rotation, as set in parameter No. 1260. This can prevent coordinates for the rotation axis from overflowing. Displayed values for relative coordinates are also rounded by the angle corresponding to one rotation when bit 2 (RRL_x) of parameter No. 1008 is set to 1. The roll-over function is enabled by setting bit 0 (ROA_x) of parameter 1008 to 1.

For an absolute command, the coordinates after the tool has moved are values rounded by the angle corresponding to one rotation set in parameter No. 1260. The tool moves in the direction in which the final coordinates are closest when bit 1 of parameter No. 1008 is set to 0. For an incremental command, the tool moves the angle specified in the command.

If the rotation axis control function is used together with an absolute command issued for an rotation axis, the axis rotation direction and the coordinates of the end point are determined according to, respectively, the algebraic sign and absolute value of a value specified in the absolute command. The function is enabled by selecting a roll-over function for the rotation axis (parameter No. 1008 (ROA_x) = 1). If the RAA_x parameter (bit 3 of No. 1008) is 1, issuing an absolute command for a rotation axis with the roll-over function selected causes the axis rotation direction and the coordinates of the end point to match, respectively, the algebraic sign and absolute value of a value specified in the absolute command. If the RAA_x parameter (bit 3 of No. 1008) is 0, the axis rotation direction and the coordinates of the end point are caused to match the setting of the RAB_x parameter (bit 1 of parameter No. 1008). (The rotation axis control function is an option.)

Parameter

	#7	#6	#5	#4	#3	#2	#1	#0
1006							ROSx	ROTx

NOTE
 After setting this parameter, turn the power off then on again so that the setting will take effect.

[Data type] Bit axis

ROTx, ROSx Setting linear or rotation axis.

ROSx	ROTx	Meaning
0	0	Linear axis (1) Inch/metric conversion is done. (2) All coordinate values are linear axis type. (Not rounded in 0 to 360°) (3) Stored pitch error compensation is linear axis type (Refer to parameter No. 3624)
0	1	Rotation axis (A type) (1) Inch/metric conversion is not done. (2) Machine coordinate values are rounded in 0 to 360°. Absolute coordinate values and relative coordinate values are rounded or not rounded by parameter No. 1008#0 and #2. (3) Stored pitch error compensation is the rotation type. (Refer to parameter No. 3624) (4) Automatic reference position return (G28, G30) is done in the reference position return direction and the move amount does not exceed one rotation.
1	0	Setting is invalid (unused)
1	1	Rotation axis (B type) (1) Inch/metric conversion is not done. (2) Machine coordinate values, absolute coordinate values and relative coordinate values are linear axis type. (Is not rounded in 0 to 360°) (3) Stored pitch error compensation is linear axis type (Refer to parameter No. 3624) (4) The rotation axis roll over function and index table indexing function (M series) cannot be used.

	#7	#6	#5	#4	#3	#2	#1	#0
1008					RAAx	RRLx	RABx	ROAx

NOTE
 After setting this parameter, turn the power off then on again so that the setting will take effect.

[Data type] Bit axis

ROAx The roll-over function of a rotation axis is

- 0 : Invalid
- 1 : Valid

NOTE

ROAx specifies the function only for a rotation axis (for which ROTx, #0 of parameter No. 1006, is set to 1)

RABx In the absolute commands, the axis rotates in the direction
 0 : In which the distance to the target is shorter.
 1 : Specified by the sign of command value.

NOTE

RABx is valid only when ROAx is 1.

RRLx Relative coordinates are
 0 : Not rounded by the amount of the shift per one rotation
 1 : Rounded by the amount of the shift per one rotation

NOTE

- 1 RRLx is valid only when ROAx is 1.
- 2 Assign the amount of the shift per one rotation in parameter No. 1260.

RAAx The rotation direction of a rotation axis and end point coordinates in the absolute command mode:
 0 : Agree with the setting of bit 1 (RABx) of parameter No.1008.
 1 : Agree with the absolute value of the specified value for the end point cxncxrdimates and the sign of the specified value for the rotation direction.

NOTE

- 1 RAAx is valid only when ROAx is 1.
- 2 Using this function requires the "rotation axis control" option.

1260

Amount of a shift per one rotation of a rotation axis

NOTE

- 1 After setting the parameter, turn off the power once and turn it on again to operate the machine.
- 2 This parameter is valid only when ROAx = 1.

[Data type] Two-word axis

[Unit of data]	Increment system	Unit of data	Standard value	Unit
	IS-A	0.01	36000	deg
	IS-B	0.001	360000	
	IS-C	0.0001	3600000	

[Valid data range] 1000 to 9999999

Set the amount of a shift per one rotation of a rotation axis.

Note

NOTE

- 1 Rotary axis roll-over function cannot be used together with the indexing function of the index table.
- 2 The rotation axis control function is an option.
- 3 The rotation axis control function is enabled for a rotation axis for which a roll-over function is selected.
- 4 If the RAAx parameter (bit 3 of No. 1008) is 1 for the rotation axis control function, the RABx parameter (bit 1 of parameter No. 1008) is ignored. If shorter-distance processing is needed, reset both the RAAx and RABx parameters to 0.
- 5 The rotation axis control function is not supported when a machine coordinate system is selected for the PMC axis control function.

Reference item

Series 16i/18i/160i/180i/ 160is/180is	OPERATOR'S MANUAL (For Machining Center) (B-63534EN)	II.20.2	Rotary Axis Roll-over
	OPERATOR'S MANUAL (For Lathe) (B-63524EN)	II.19.2	Rotary Axis Roll-over
Series 21i/210i/210is	OPERATOR'S MANUAL (For Machining Center) (B-63614EN)	II.20.2	Rotary Axis Roll-over
	OPERATOR'S MANUAL (For Lathe) (B-63604EN)	II.19.2	Rotary Axis Roll-over
Series 20i	OPERATOR'S MANUAL (For Manual Milling Machine) (B-64204EN)	II.18.1	Rotary Axis Roll-over

1.2.4 Controlled Axes Detach

General

These signals release the specified control axes from control by the CNC. When attachments are used (such as a detachable rotary table), these signals are selected according to whether the attachments are mounted. The signals can also be used for switching the C axis and spindle on lathes.

When multiple rotary tables are used in turn, the tables must use motors of the same model. Absolute pulse coders cannot be used.

Signal

Controlled axis detach signals DTCH1 – DTCH8 <G124>

[Classification] Input signal

[Function] These signals detach the control axes from control. These signals are provided for each control axis; the affixed number of the signal name shows the control axis number.

DTCH 1	
├──	1 The 1st axis is detached.
├──	2 The 2nd axis is detached.
├──	: :
├──	: :
└──	8 The 8th axis is detached.

[Operation] When the signals are 1, the control unit operates as follows:

- 1) Position control is not executed at all. Servo motor excitation is cut.
- 2) Servo alarm on the axis is ignored.
- 3) Axis interlock signal is assumed to be zero on the detached axis.
- 4) A command for automatic or manual operation is effective for the axis, but do not execute the command. The command is accepted but the operation is restrained, because the axis interlock is 0. In an automatic operation, the execution may stop and hold at the block.
- 5) Position display also displays the position of the detached axis.

**Controlled axis detach
status signals
MDTCH1 – MDTCH8
<F110>**

[Classification] Output signal

[Function] These signals notify the PMC that the corresponding axes have been released from control.

These signals are provided for each control axis; the affixed number of the signal name shows the control axis number.

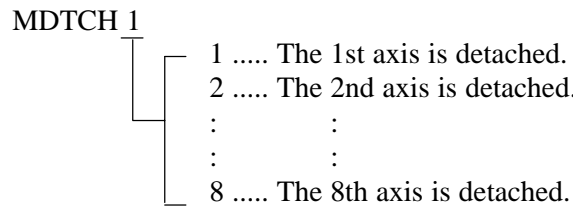

[Output condition] These signals are 1 in the following case:

- When the corresponding axes are released from control

These signals are 0 in the following case:

- When the corresponding axes are under control

Signal address

	#7	#6	#5	#4	#3	#2	#1	#0
G124	DTCH8	DTCH7	DTCH6	DTCH5	DTCH4	DTCH3	DTCH2	DTCH1
	#7	#6	#5	#4	#3	#2	#1	#0
F110	MDTCH8	MDTCH7	MDTCH6	MDTCH5	MDTCH4	MDTCH3	MDTCH2	MDTCH1

Parameter

	#7	#6	#5	#4	#3	#2	#1	#0
0012	RMVx							

Setting entry is acceptable.

[Data type] Bit axis

RMVx Releasing the assignment of the control axis for each axis

0 : Not released

1 : Released

NOTE

RMVx is valid when the bit 7 (RMBx) in parameter 1005 is 1.

	#7	#6	#5	#4	#3	#2	#1	#0
1005	RMBx	MCCx						

[Data type] Bit axis

RMBx Releasing the assignment of the control axis for each axis (signal input and setting input)

0 : Invalid

1 : Valid

MCCx When an axis is released from control, control for the MCC signal for the corresponding servo amplifier is

0 : Disabled

1 : Enabled

NOTE

If the servo motor for an axis is connected to a 2-axis or other multiaxis amplifier, releasing the axis from control causes servo alarm 401 (V ready off) to be output. This alarm can be disabled by this parameter. When the servo motor is disconnected from the CNC, however, servo alarm 401 is output, regardless of the value of the parameter, due to the nature of multiaxis amplifier.

Caution**CAUTION**

When a 2-axis or 3-axis amplifier is used, releasing only one axis from control results in the output of servo alarm 401 (V ready off). Use 1-axis amplifiers for those axes to be released from control, e.g., by replacing the rotary table.

Note**NOTE**

- 1 Controlled axis detach signals DTCH1 <G124#0>, DTCH2 <G124#1>, DTCH3 <G124#2>, ... can be changed from 1 to 0 or from 0 to 1 when the power is first turned on or when no movement is being executed along the corresponding axis. If these signals are changed from 0 to 1 when the tool is moving along the corresponding axis, the axis is released from control upon completion of the movement.
- 2 For these signals to be attached, parameter No. 1005#7 must be set, indicating the axes are detachable.
- 3 Setting parameter No. 0012#7 from the MDI panel detaches the axes in the same way as these signals.
- 4 Those axes that are released from control lose their reference positions. Reference position return must, therefore, be performed for the axes prior to executing move commands for the axes. Specifying a move command before reference position return has been performed causes alarm 224 to be output (the alarm can be disabled by setting bit 0 (ZRNx) of parameter 1005).

1.2.5 Outputting the Movement State of an Axis

General

The movement state of each axis can be output to the PMC.

Signal

Axis moving signals MV1 – MV8 <F102>

[Classification] Output signal

[Function] These signals indicate that a control axis is moving. The signals are provided for each control axis, and the number in the signal name corresponds to the control axis number.

MV 1		
	1 The 1st axis is moving.
	2 The 2nd axis is moving.
	3 The 3rd axis is moving.
	:	:
	:	:

[Output condition] The signals turn to “1” in the following cases:

- . The corresponding axis has started moving.
- . In manual handle feed mode, the handle feed axis of the corresponding axis has been selected.

The signals turn to “0” in the following case:

- . When the move command for the corresponding axis has been distributed (when bit 6 (MVX) of parameter 3003 is 0)
- . When deceleration for the corresponding axis has been completed and the axis is set to the in-position condition. If in-position check is not performed, when the deceleration for the corresponding axis is completed. (When bit 6 (MVX) of parameter 3003 is 1)

Setting 1 in bit 7 (MVG) of parameter 3003 prevents these signals from being output during drawing in dynamic graphics mode (drawing without movement of the machine) in the T system.

In the M system, axis moving signals are not output.

Axis moving direction signals

MVD1 – MVD8 <F106>

[Classification] Output signal

[Function] These signals indicate the movement direction of control axis. They are provided for each control axis, and the number in the signal name corresponds to the control axis number.

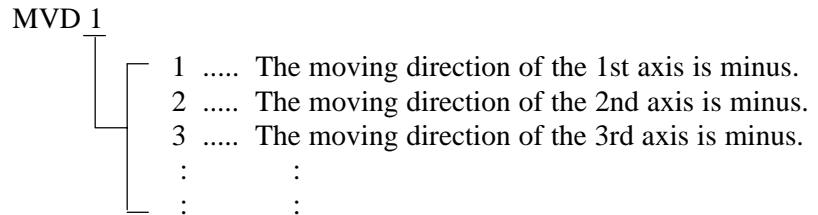

[Output condition] “1” indicates the corresponding axes are moving in the minus direction, and “0” indicates they are moving in the plus direction.

CAUTION
 These signals maintain their condition during a stop, indicating the direction of the axes’ movement before stopping.

Signal address

	#7	#6	#5	#4	#3	#2	#1	#0
F102	MV8	MV7	MV6	MV5	MV4	MV3	MV2	MV1
F106	MVD8	MVD7	MVD6	MVD5	MVD4	MVD3	MVD2	MVD1

Parameter

- **Setting the output format of the axis moving signal**

	#7	#6	#5	#4	#3	#2	#1	#0
3003	MVG	MX						
		MX						

[Data type] Bit

MX The axis moving signal is set to 0 when:
 0 : Distribution for the axis is completed. (The signal is set to 0 in deceleration.)
 1 : Deceleration of the axis is terminated, and the current position is in the in-position.
 When the deceleration-time in-position check is suppressed by setting bit 5 (NCI) of parameter No. 1601, the signal is set to 0 at the end of deceleration.

MVG While drawing using the dynamic graphics function (with no machine movement), the axis moving signal is:
 0: Output
 1: Not output

Caution**CAUTION**

Axis moving signals and axis moving direction signals are output in both automatic and manual operations.

1.2.6 Mirror Image

General

Mirror image can be applied to each axis, either by signals or by parameters (setting input is acceptable). All movement directions are reversed during automatic operation along axes to which a mirror image is applied.

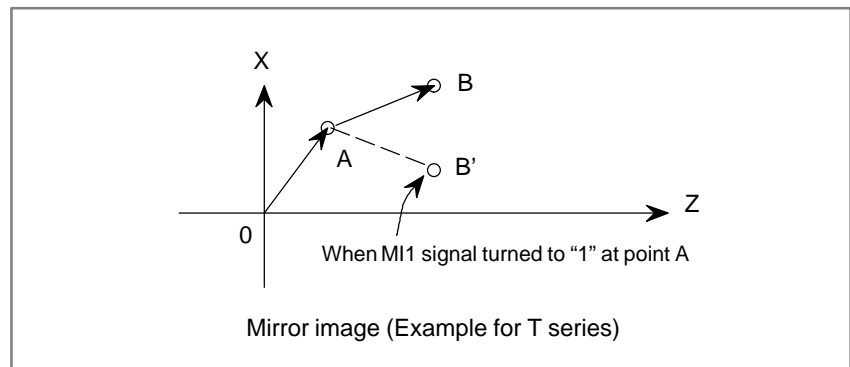

However, the following directions are not reversed:

- Direction of manual operation and direction of movement, from the intermediate position to the reference position during automatic reference position return (for the M and T series)
- Approach direction for single direction positioning (G60) and shift direction for boring cycles (G76 and G87) (for M series only)

Mirror image check signals indicate whether mirror image is applied to each axis. System variable #3007 contains the same information (refer to the operator's manual).

Signal

Mirror image signal MI1 – MI8 <G106>

[Classification] Input signal

[Function] Apply mirror image to the specified axes.

[Operation] Apply mirror image to those axes for which the signals are 1. These signals are provided for the controlled axes on a one-to-one basis. A number appended to a signal represents the controlled axis number.

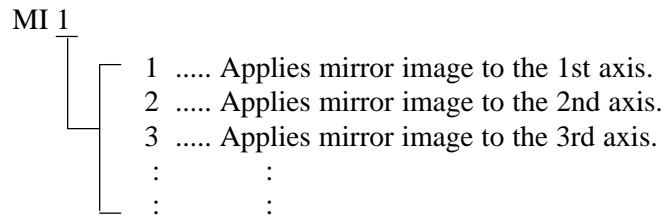

The mirror image signal can be turned to “1” in the following cases:

- a) During offset cancel;
- b) When the CNC is in the automatic operation stop state and not in the feed hold state.

Mirror image check signal

MMI1 – MMI8<F108>

[Classification] Output signal

[Function] These signals indicate the mirror image condition of each axis. The mirror image is set by taking the logical sum of the signal from the MDI panel and the input signal of the machine tool, then relaying the information to the machine tool.

These signals are provided for every control axis; the numeral in the signal name indicates the relevant control axis number.

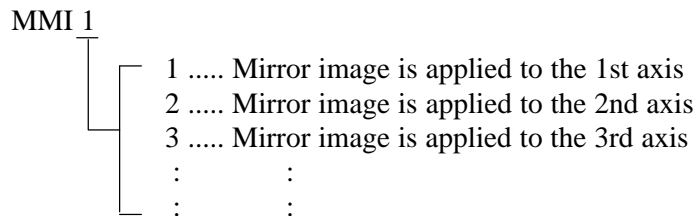

[Output condition] These signals turn to “1” when:

- Mirror image signal MIn of the corresponding axis is “1”; or
- Mirror image of the corresponding axis is turned on by setting data from the MDI panel.

These signals turn to “0” when:

- Mirror image signal (MIn) of the corresponding axis is “0” and the setting of the mirror image in the control unit is turned off.

Signal address

	#7	#6	#5	#4	#3	#2	#1	#0
G106	MI8	MI7	MI6	MI5	MI4	MI3	MI2	MI1
	#7	#6	#5	#4	#3	#2	#1	#0
F108	MMI8	MMI7	MMI6	MMI5	MMI4	MMI3	MMI2	MMI1

Parameter

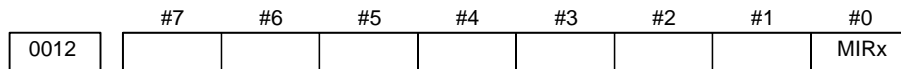

The following parameter can be set at “Setting screen.”

[Data type] Bit axis

MIRx Mirror image for each axis

0 : Mirror image is off.

1 : Mirror image is on.

Warning

WARNING

- 1 When programmable mirror image (M series) and ordinary mirror image are specified at the same time, programmable mirror image is applied first.
- 2 No programmable mirror image (M series) affects mirror image check signals MMI1 to MMI8 <F108>.

Caution

CAUTION

Even when the mirror image is applied, commands which do not actuate mirror image (such as automatic reference position return and manual operation) do not affect mirror image check signals MMI1 to MMI8 <F108>.

Reference item

Series 16i/18i/160i/180i/ 160is/180is	OPERATOR'S MANUAL (For Machining Center) (B-63534EN)	III.4.9	Mirror Image
	OPERATOR'S MANUAL (For Lathe) (B-63524EN)	III.4.7	Mirror Image
Series 21i/210i/210is	OPERATOR'S MANUAL (For Machining Center) (B-63614EN)	III.4.8	Mirror Image
	OPERATOR'S MANUAL (For Lathe) (B-63604EN)	III.4.7	Mirror Image

1.2.7 Follow-up

General

When position control is disabled for the controlled axes (when the servo is off, during emergency stop, or during a servo alarm), if the machine is moved, a positional error occurs. Follow-up is a function for changing the current position of the CNC and resetting the error counter to zero. Assuming a command corresponding to the error has been specified. You can select whether to perform follow-up for axes when the servo is turned off. Follow-up is always performed during emergency stop or a servo alarm.

- **When follow-up is not performed for the axes for which the servo is turned off**

When signal *FLWU is 1 or bit 0 (FUPx) of parameter 1819 is 1, follow-up is not performed. The error is added to the error counter as a servo error. In this case, the machine moves to compensate for the error when the servo off signal changes to 0. In general, follow-up is not used if the machine is mechanically clamped when position control is disabled for the controlled axes.

- **When follow-up is performed for the axes for which the servo is turned off**

When *FLWU is "0", the follow-up function is engaged. The present position of the CNC is changed to reset the error counter to zero. The machine tool remains in a deviated position, but since the present position of the CNC changes correspondingly, the machine moves to the correct position when the absolute command is next applied. In general, follow-up should be used when motors are driven by mechanical handles.

Signal

Follow-up signal *FLWU <G007#5>

[Classification] Input signal

[Function] Select whether to perform follow-up when the servo is turned off for those axes for which bit 0 (FUPx) of parameter 1819 is 0.

[Operation] 0: Performs follow-up.
1: Does not perform follow-up.

Signal address

	#7	#6	#5	#4	#3	#2	#1	#0
G007			*FLWU					

Parameter

	#7	#6	#5	#4	#3	#2	#1	#0
1819								FUPx

[Data type] Bit axis**FUPx** To perform follow-up when the servo is off for each axis.

0 : The follow-up signal, *FLWU, determines whether follow-up is performed or not.

When *FLWU is 0, follow-up is performed.

When *FLWU is 1, follow-up is not performed.

1 : Follow-up is not performed.

CAUTION

When the index table indexing function (M series) is used, be sure to set FUPx of the 4th axis to 1.

Reference item

CONNECTION MANUAL (This manual)	1.2.8	Servo Off (Mechanical handle)
------------------------------------	-------	-------------------------------

1.2.8 Servo Off (Mechanical Handle)

General

Place the controlled axes in the servo off state, stop the current to the servo motor, which disables position control. However, the position detection feature functions continuously, so the current position is not lost. These signals are used to prevent the servo motors from overloading when the tools on the axes are mechanically clamped under certain machining conditions on the machine, or to move the machine by driving the motors by mechanical handles.

Signal

Servo off signal SVF1 – SVF8 <G126>

[Classification] Input signal

[Function] Select whether to place each axis in the servo off state.

These signals are provided for the controlled axes on a single axis basis. A number appended to a signal represents a controlled axis number.

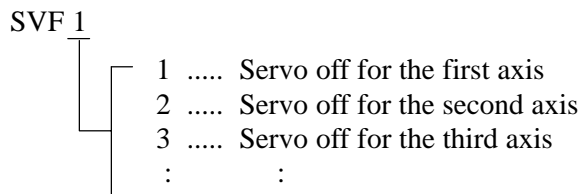

[Operation] These signals put the axes for which the signals are 1 in the servo off state (the current to the servo motor is stopped). This disables position control. However, the position detection feature continues to function, so the current position is not lost.

Signal address

	#7	#6	#5	#4	#3	#2	#1	#0
G126	SVF8	SVF7	SVF6	SVF5	SVF4	SVF3	SVF2	SVF1

Caution

CAUTION

- 1 In general, interlock is applied to an axis while the servo off signal for that axis is 1.
- 2 When one of these signals turns to "1", the servo motor is turned off. The mechanical clamp is done by using the auxiliary function. Set the timing for the auxiliary function, mechanical clamp and servo off signals as shown in the diagram below. The clamp command auxiliary function should be executed only after the distribution end signal (DEN) turned to "1".

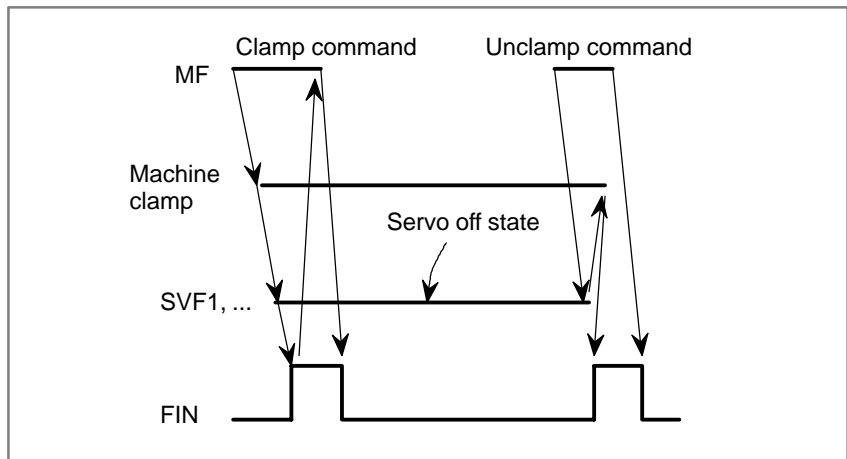

Reference item

CONNECTION MANUAL (This manual)	1.2.7	Follow-up
------------------------------------	-------	-----------

1.2.9 Position Switch

General

Position switch signals can be output to the PMC while the machine coordinates along a controlled axes are within a specified ranges.

Signal

Position switch signal PSW01 – PSW16 <F070#0 – F071#7>

[Classification] Output signal

[Function] Indicates that the machine coordinates along the controlled axes specified by parameters (6910 to 6925) are within the ranges specified by parameters (6930 to 6945 and 6950 to 6965). Up to 16 position switch signals can be output.
(Using 11 or more position switches requires setting the EPS parameter (bit 1 of No. 6901.)

[Output condition] These signals are 1 in the following case:

- When the machine coordinates along the controlled axes are within the specified ranges.

These signals are 0 in the following case:

- When the machine coordinates along the controlled axes are not within the specified ranges.

Signal address

	#7	#6	#5	#4	#3	#2	#1	#0
F070	PSW08	PSW07	PSW06	PSW05	PSW04	PSW03	PSW02	PSW01
F071	PSW16	PSW15	PSW14	PSW13	PSW12	PSW11	PSW10	PSW09

Parameter

- Increasing the number of position switch signals

	#7	#6	#5	#4	#3	#2	#1	#0
6901					PSF	PCM	EPS	IGP

[Data type] Bit

IGP During follow-up for the absolute position detector, position switch signals are:

0 : Output

1 : Not output

EPS The number of position switches is:

0 : Up to 10.

1 : Up to 16.

PCM Position switch signals are output:

0 : Without considering acceleration/deceleration and servo delay.

1 : With considering acceleration/deceleration and servo delay.

PSF In high-precision contour control mode (M series), AI contour control mode (M series), AI nano-contour control mode (M series), AI advanced preview control (21i-M), or advanced preview control mode, position switches are:

0 : Not used.

1 : Used.

To use the position switches in any of the following modes, set this parameter:

High-precision contour control mode (M series), AI contour control mode (M series), AI nano-contour control mode (M series), AI advanced preview control mode (21i-M), or advanced preview control mode

NOTE

1 The position switch signals are output considering acceleration/deceleration after interpolation and servo delay. Acceleration/deceleration after interpolation and servo delay are considered even for position switch signal output in a mode other than the high-precision contour control (M series), AI contour control (M series), AI nano contour control (M series), AI look-ahead control (21i-M), and look ahead control modes. When this parameter is set to 1, however, signals are output from the position switches at different times from the specified ones.

2 When using the high-speed position switch of decision-by-direction type, set bit 1 (HPE) of parameter No. 8501 to 0 (to consider a servo delay amount for decision of direction).

● **Setting the correspondence between the position switch signals and the controlled axes**

6910	Axis corresponding to the first position switch
6911	Axis corresponding to the second position switch
6912	Axis corresponding to the third position switch
6913	Axis corresponding to the fourth position switch
6914	Axis corresponding to the fifth position switch
6915	Axis corresponding to the sixth position switch
6916	Axis corresponding to the seventh position switch
6917	Axis corresponding to the eighth position switch
6918	Axis corresponding to the ninth position switch
6919	Axis corresponding to the tenth position switch
6920	Axis corresponding to the eleventh position switch
6921	Axis corresponding to the twelfth position switch
6922	Axis corresponding to the thirteenth position switch
6923	Axis corresponding to the fourteenth position switch
6924	Axis corresponding to the fifteenth position switch
6925	Axis corresponding to the sixteenth position switch

[Data type] Byte

[Valid data range] 0 to Number of controlled axes

These parameters sequentially specify the numbers of the controlled axes corresponding to the 1st through 16th position switch functions. The corresponding position switch signal is output to the PMC when the machine coordinate of the corresponding axis is within the range set in parameters.

NOTE

- 1 Set 0 for the number corresponding to a position switch which is not to be used.
- 2 Parameter Nos. 6920 to 6925 are valid only when bit 1 (EPS) of parameter No. 6901 is 1.

- **Setting the machine coordinate ranges for which the position switch signals are output**

- **Maximum operation range**

6930	Maximum operation range of the first position switch
6931	Maximum operation range of the second position switch
6932	Maximum operation range of the third position switch
6933	Maximum operation range of the fourth position switch
6934	Maximum operation range of the fifth position switch
6935	Maximum operation range of the sixth position switch
6936	Maximum operation range of the seventh position switch
6937	Maximum operation range of the eighth position switch
6938	Maximum operation range of the ninth position switch
6939	Maximum operation range of the tenth position switch
6940	Maximum operation range of the eleventh position switch
6941	Maximum operation range of the twelfth position switch
6942	Maximum operation range of the thirteenth position switch
6943	Maximum operation range of the fourteenth position switch
6944	Maximum operation range of the fifteenth position switch
6945	Maximum operation range of the sixteenth position switch

[Data type] 2-word

[Unit of data]	Increment system	IS-A	IS-B	IS-C	Unit
	Metric machine	0.01	0.001	0.0001	mm
	Inch machine	0.001	0.0001	0.00001	inch
	Rotation axis	0.01	0.001	0.0001	deg

[Valid data range] -99999999 to 99999999

These parameters sequentially set the maximum operation ranges of the 1st through 16th position switches.

NOTE

Parameter Nos. 6940 to 6945 are valid only when bit 1 (EPS) of parameter No. 6901 is 1.

● **Minimum operation range**

6950	Minimum operation range of the first position switch
6951	Minimum operation range of the second position switch
6952	Minimum operation range of the third position switch
6953	Minimum operation range of the fourth position switch
6954	Minimum operation range of the fifth position switch
6955	Minimum operation range of the sixth position switch
6956	Minimum operation range of the seventh position switch
6957	Minimum operation range of the eighth position switch
6958	Minimum operation range of the ninth position switch
6959	Minimum operation range of the tenth position switch
6960	Minimum operation range of the eleventh position switch
6961	Minimum operation range of the twelfth position switch
6962	Minimum operation range of the thirteenth position switch
6963	Minimum operation range of the fourteenth position switch
6964	Minimum operation range of the fifteenth position switch
6965	Minimum operation range of the sixteenth position switch

[Data type] 2-word

[Unit of data]	Increment system	IS-A	IS-B	IS-C	Unit
	Metric machine	0.01	0.001	0.0001	mm
	Inch machine	0.001	0.0001	0.00001	inch
	Rotation axis	0.01	0.001	0.0001	deg

[Valid data range] -99999999 to 99999999

These parameters sequentially set the minimum operation ranges of the 1st through 16th position switches.

NOTE

Parameter Nos. 6960 to 6965 are valid only when bit 1 (EPS) of parameter No. 6901 is 1.

1.2.10 High-Speed Position Switch

General

The high-speed position switch function obtains the current position along an arbitrary controlled axis from the machine coordinate values and a feedback signal from the position detector, and outputs a signal if the current position is within a certain range. Because this function has a shorter supervisory period than an ordinary position switch function, it supports faster, more accurate monitoring. The function can output up to 16 high-speed position switch signals.

Signal

Signals are used to notify that the current position along an axis corresponding to each high-speed position switch is within a range specified by a parameter.

High-speed position switch signal HPS01 – HPS16 <Yxx#0 – Yxx+1#7>

[Classification] Output signal

[Function] These signals are used to notify that the current position along an axis corresponding to each high-speed position switch is within a range specified by a parameter.

The following table lists the relationships between the output addresses for each high-speed position switch and parameters.

Relationships between high-speed position switches and output addresses

	Output signal address	Controlled-axis number	Maximum operating range	Minimum operating range
1st to 8th	Value of parameter No. 8565	8570 to 8577	8580 to 8587	8590 to 8597
9th to 16th	Value of parameter No. 8565 plus 1	8578 to 8579, 12201 to 12206	8588 to 8589, 12221 to 12226	8598 to 8599, 12241 to 12246

[Output condition] These signals are 1 in the following case:

- When the current position along the controlled axis is within a specified range.

These signals are 0 in the following case:

- When the current position the along the controlled axis is not within a specified range.

Signal address

	#7	#6	#5	#4	#3	#2	#1	#0
Yxx	HPS08	HPS07	HPS06	HPS05	HPS04	HPS03	HPS02	HPS01
Yxx+1	HPS16	HPS15	HPS14	HPS13	HPS12	HPS11	HPS10	HPS09

Parameter

	#7	#6	#5	#4	#3	#2	#1	#0
6901								IGP

[Data type] Bit

IGP During follow-up for the absolute position detector, position switch signals are:

0 : Output

1 : Not output

NOTE

This parameter is used also for the ordinary position switch function.

	#7	#6	#5	#4	#3	#2	#1	#0
8500	EPS							

[Data type] Bit

EPS The maximum number of high-speed position switches is:

0 : 6.

1 : 16.

	#7	#6	#5	#4	#3	#2	#1	#0
8504	HE8	HE7	HE6	HE5	HE4	HE3	HE2	HE1
	#7	#6	#5	#4	#3	#2	#1	#0
8505	HEG	HEF	HEE	HED	HEC	HEB	HEA	HE9

[Data type] Bit

HE1 to HEG The corresponding high-speed position switch is:

0 : Enabled.

1 : Disabled. (A disabled high-speed position switch always outputs 0.)

NOTE

The two-digit number in each parameter name corresponds to the order of the high-speed position switch.

8565

High-speed position switch output address 1

[Data type] Word**[Valid data range]** 1 to 126

This parameter specifies the address of a Y signal used to notify that the axis corresponding to each high-speed position switch is within a range specified by a parameter. The following table lists the relationships between high-speed position switches and output addresses.

Relationships between high-speed position switches and output addresses

	Output signal address	Controlled-axis number	Maximum operating range	Minimum operating range
1st to 8th	Value of parameter No. 8565	8570 to 8577	8580 to 8587	8590 to 8597
9th to 16th	Value of parameter No. 8565 plus 1	8578 to 8579, 12201 to 12206	8588 to 8589, 12221 to 12226	8598 to 8599, 12241 to 12246

WARNING

- 1 Be sure not to use any Y signal already used in the PMC ladder with this function. If used, the machine may behave in an unexpected manner.
- 2 If you want to use high-speed position switches for multiple paths, use a different Y signal output address for each path.

CAUTION

- 1 Specifying a nonexistent address causes the high-speed position switch function to be disabled.
- 2 After setting this parameter, turn the power off then on again so that the setting will take effect.
- 3 Y signal address Y127 cannot be specified for this function.
- 4 Address output signals (Y1001 and above) on the M-NET board cannot be specified for this function.

8570	Axis corresponding to the first high-speed position switch
8571	Axis corresponding to the second high-speed position switch
8572	Axis corresponding to the third high-speed position switch
8573	Axis corresponding to the fourth high-speed position switch
8574	Axis corresponding to the fifth high-speed position switch
8575	Axis corresponding to the sixth high-speed position switch
8576	Axis corresponding to the seventh high-speed position switch
8577	Axis corresponding to the eighth high-speed position switch
8578	Axis corresponding to the ninth high-speed position switch
8579	Axis corresponding to the tenth high-speed position switch
12201	Axis corresponding to the eleventh high-speed position switch
12202	Axis corresponding to the twelfth high-speed position switch
12203	Axis corresponding to the thirteenth high-speed position switch
12204	Axis corresponding to the fourteenth high-speed position switch
12205	Axis corresponding to the fifteenth high-speed position switch
12206	Axis corresponding to the sixteenth high-speed position switch

[Data type] Byte

[Valid data range] 0 to Number of controlled axes

These parameters specify the controlled-axis numbers corresponding to each high-speed position switch function. If the current position along the corresponding axis is within a range specified by a parameter, the corresponding high-speed position switch signal is output. If the parameter value is 0, it means that the high-speed position switch function corresponding to the number is not used.

NOTE

Parameter Nos. 8576 to 8579 and 12201 to 12206 are valid only when bit 7 (EHP) of parameter No. 8500 is 1.

8580	Maximum value of the operation range of the first high-speed position switch or position where the first high-speed position switch is turned on
8581	Maximum value of the operation range of the second high-speed position switch or position where the second high-speed position switch is turned on
8582	Maximum value of the operation range of the third high-speed position switch or position where the third high-speed position switch is turned on
8583	Maximum value of the operation range of the fourth high-speed position switch or position where the fourth high-speed position switch is turned on
8584	Maximum value of the operation range of the fifth high-speed position switch or position where the fifth high-speed position switch is turned on
8585	Maximum value of the operation range of the sixth high-speed position switch or position where the sixth high-speed position switch is turned on
8586	Maximum value of the operation range of the seventh high-speed position switch or position where the seventh high-speed position switch is turned on
8587	Maximum value of the operation range of the eighth high-speed position switch or position where the eighth high-speed position switch is turned on
8588	Maximum value of the operation range of the ninth high-speed position switch or position where the ninth high-speed position switch is turned on
8589	Maximum value of the operation range of the tenth high-speed position switch or position where the tenth high-speed position switch is turned on
12221	Maximum value of the operation range of the eleventh high-speed position switch or position where the eleventh high-speed position switch is turned on
12222	Maximum value of the operation range of the twelfth high-speed position switch or position where the twelfth high-speed position switch is turned on
12223	Maximum value of the operation range of the thirteenth high-speed position switch or position where the thirteenth high-speed position switch is turned on
12224	Maximum value of the operation range of the fourteenth high-speed position switch or position where the fourteenth high-speed position switch is turned on
12225	Maximum value of the operation range of the fifteenth high-speed position switch or position where the fifteenth high-speed position switch is turned on
12226	Maximum value of the operation range of the sixteenth high-speed position switch or position where the sixteenth high-speed position switch is turned on

[Data type] 2-word

[Unit of data]	Increment system	IS-B	IS-C	Unit
	Metric machine	0.001	0.0001	mm
	Inch machine	0.0001	0.00001	inch
	Rotation axis	0.001	0.0001	deg

[Valid data range] -99999999 to 99999999

These parameters set the maximum operating range for each high-speed position switch. Specifying "maximum value < minimum value" disables the high-speed position switch from working because there is no valid operating range.

NOTE

Parameter Nos. 8586 to 8589 and 12221 to 12226 are valid only when bit 7 (EHP) of parameter No. 8500 is 1.

8590	Minimum value of the operation range of the first high-speed position switch or position where the first high-speed position switch is turned off
8591	Minimum value of the operation range of the second high-speed position switch or position where the second high-speed position switch is turned off
8592	Minimum value of the operation range of the third high-speed position switch or position where the third high-speed position switch is turned off
8593	Minimum value of the operation range of the fourth high-speed position switch or position where the fourth high-speed position switch is turned off
8594	Minimum value of the operation range of the fifth high-speed position switch or position where the fifth high-speed position switch is turned off
8595	Minimum value of the operation range of the sixth high-speed position switch or position where the sixth high-speed position switch is turned off
8596	Minimum value of the operation range of the seventh high-speed position switch or position where the seventh high-speed position switch is turned off
8597	Minimum value of the operation range of the eighth high-speed position switch or position where the eighth high-speed position switch is turned off
8598	Minimum value of the operation range of the ninth high-speed position switch or position where the ninth high-speed position switch is turned off
8599	Minimum value of the operation range of the tenth high-speed position switch or position where the tenth high-speed position switch is turned off
12241	Minimum value of the operation range of the eleventh high-speed position switch or position where the eleventh high-speed position switch is turned on
12242	Minimum value of the operation range of the twelfth high-speed position switch or position where the twelfth high-speed position switch is turned on
12243	Minimum value of the operation range of the thirteenth high-speed position switch or position where the thirteenth high-speed position switch is turned on
12244	Minimum value of the operation range of the fourteenth high-speed position switch or position where the fourteenth high-speed position switch is turned on

12245	Minimum value of the operation range of the fifteenth high-speed position switch or position where the fifteenth high-speed position switch is turned on
12246	Minimum value of the operation range of the sixteenth high-speed position switch or position where the sixteenth high-speed position switch is turned on

[Data type] 2-word

[Unit of data]	Increment system	IS-B	IS-C	Unit
	Metric machine	0.001	0.0001	mm
	Inch machine	0.0001	0.00001	inch
	Rotation axis	0.001	0.0001	deg

[Valid data range] -99999999 to 99999999

These parameters set the minimum operating range for each high-speed position switch. Specifying "maximum value < minimum value" disables the high-speed position switch from working because there is no valid operating range.

NOTE

Parameter Nos. 8596 to 8599 and 12241 to 12246 are valid only when bit 7 (EHP) of parameter No. 8500 is 1.

1.2.11 Direction-Sensitive High-Speed Position Switch

General

This function monitors machine coordinate values and the direction of operations related to arbitrary controlled axes and turns on or off the output of the high-speed position switch signal. Two machine coordinate values can be monitored. If a position specified by one of the machine coordinate values is passed through in a specified direction, the signal becomes on. If a position specified by the other machine coordinate value is passed through in a specified direction, the signal becomes off. These coordinate values and directions are specified by parameters. Up to 16 signals can be specified. Using this function requires the high-speed position switch function.

Details of the function

This function obtains the current position and its movement direction from machine coordinate values and a feedback signal received from the position detector at 2 ms intervals. If a specified position (point A) is passed through in a specified direction, a signal is output. If a specified position (point B) is passed through in a specified direction, the signal is discontinued. The total maximum number of direction-sensitive and ordinary high-speed position switches is 6 if bit 7 (EXHPS) of parameter No. 8500 is 0 and 16 if bit 7 (EXHPS) of parameter No. 8500 is 1. The output type (ordinary or direction-sensitive) of the high-speed position switch is selected using parameter Nos. 8508 and 8509.

Parameter No. 8565 is used to specify the address of a Y signal used for outputting a high-speed position switch signal. Specifying a nonexistent address causes the high-speed position switch function to be disabled. Parameter Nos. 8570 to 8579 and 12201 to 12206 specify the axes corresponding to each high-speed position switch. If the parameter value is 0, the corresponding high-speed position switch does not work.

For the direction-sensitive high-speed position switches, parameter Nos. 8580 to 8589 and 12221 to 12226 specify the coordinate values (point A) where the high-speed position switches become ON, and parameter Nos. 8590 to 8599 and 12241 to 12246 specify the coordinate values (point B) where the high-speed position switches become OFF. Parameter Nos. 8512 and 8513 specify the effective movement direction for coordinate values (point A) where the high-speed position switch becomes ON, and parameter Nos. 8516 and 8517 specify the effective movement direction for coordinate values (point B) where the high-speed position switch becomes OFF. If these points are passed through in the opposite direction, the high-speed position switch does not work.

The following figure illustrates the above description.

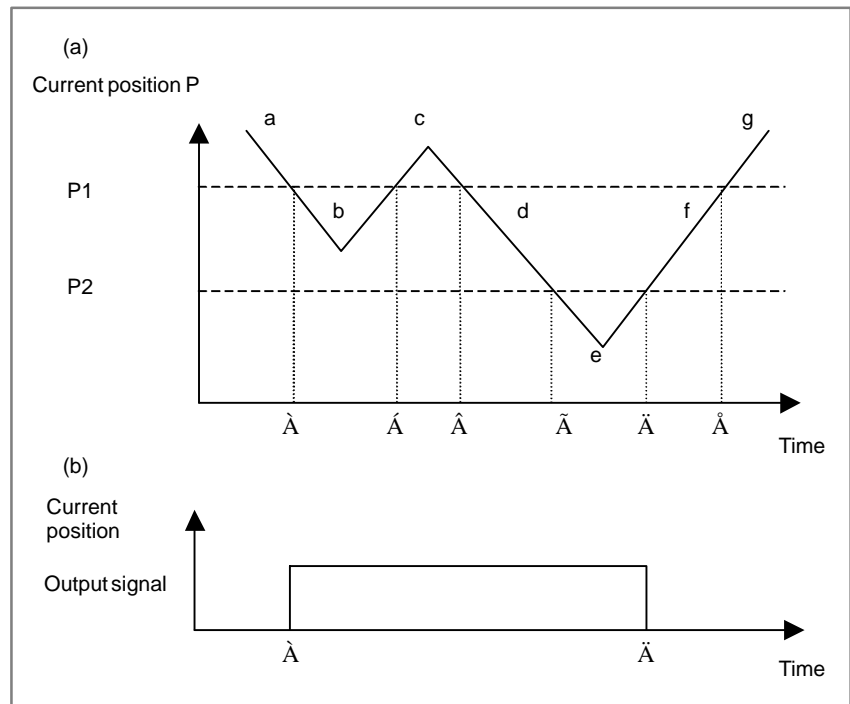

(*1) This setting specifies that, when the current position passes through P1 in the \downarrow direction, the high-speed position switch is to become ON.

(*2) This setting specifies that, when the current position passes through P2 in the \uparrow direction, the high-speed position switch is to become OFF.

In diagram (a), the horizontal axis represents time, and the vertical axis represents the coordinate values of the high-speed position switch. The current position shifts in the sequence $a \rightarrow b \rightarrow c \rightarrow d \rightarrow e \rightarrow f \rightarrow g$ as time elapses. Diagram (b) is a timing chart for indicating when the high-speed position switch is turned ON.

1. Even if the current position starts at point a, passes across border P1, and reaches point b in diagram (a), the high-speed position switch becomes ON because the passing direction is the same as defined (*1).
2. Even if the current position starts at point b, passes across border P1, and reaches point c, the high-speed position switch does not change its state (remains ON) because the passing direction is opposite to the defined direction (*1).
3. If the current position starts at point c, passes across border P1, and reaches point d, the high-speed position switch does not change its state although the passing direction is the same as defined (*1), because it is already ON.
4. Even if the current position starts at point d, passes across border P2, and reaches point e, the high-speed position switch does not change its state (remains ON) because the passing direction is opposite to the defined direction (*2).

5. If the current position starts at point e, passes across border P2, and reaches point f, the high-speed position switch becomes OFF because the passing direction is the same as defined (*2).
6. Even if the current position starts at point f, passes across border P1, and reaches point g, the high-speed position switch does not change its state (remains OFF) because the passing direction is opposite to the defined direction (*1).

Signal

Signals are used to notify that the current position along an axis corresponding to each high-speed position switch is within a range specified by a parameter.

High-speed position switch signal HPS01 – HPS16 <Yxx#0 – Yxx+1#7>

[Classification] Output signal

[Function] These signals are output if the current position along an axis corresponding to each high-speed position switch satisfies a condition. Up to 16 high-speed position switch signals can be output. This number is the total of ordinary and direction-sensitive position switches. The following table lists the relationships between the output addresses for each high-speed position switch and parameters.

Relationships between direction-sensitive high-speed position switches and output addresses

	Output signal address	Controlled -axis number	Output type switching	Enable/disable	Maximum operating range	Effective direction for point A	Minimum operating range	Effective direction for point B
1st to 8th	Value of parameter No. 8565	8570 to 8577	8508	8504	8580 to 8587	8512	8590 to 8597	8516
9th to 16th	Value of parameter No. 8565 plus 1	8578 to 8579, 12201 to 12206	8509	8505	8588 to 8589, 12221 to 12226	8513	8598 to 8599, 12241 to 12246	8517

[Output condition] These signals are 1 in the following case:

- When the current position along the controlled axis is within the specified range.

These signals are 0 in the following case:

- When the current position along the controlled axis is not within the specified range.

NOTE

- 1 The direction-sensitive high-speed position switch becomes ON at point A and OFF at point B.
- 2 The position switch does not change its state when point A or B is passed through in the direction opposite to the effective direction.
- 3 Specifying a nonexistent signal address causes the high-speed position switch function to be disabled.

Signal address

	#7	#6	#5	#4	#3	#2	#1	#0
Yxx	HPS08	HPS07	HPS06	HPS05	HPS04	HPS03	HPS02	HPS01
Yxx+1	HPS16	HPS15	HPS14	HPS13	HPS12	HPS11	HPS10	HPS09

Parameter

	#7	#6	#5	#4	#3	#2	#1	#0
6901								IGP

[Data type] Bit

IGP During follow-up for the absolute position detector, position switch signals are:
 0 : Output
 1 : Not output

NOTE

This parameter is used also for the ordinary position switch function.

	#7	#6	#5	#4	#3	#2	#1	#0
8500	EHP							

[Data type] Bit

EHP The maximum number of high-speed position switches is:
 0 : 6.
 1 : 16.

	#7	#6	#5	#4	#3	#2	#1	#0
8504	HE8	HE7	HE6	HE5	HE4	HE3	HE2	HE1
8505	HEG	HEF	HEE	HED	HEC	HEB	HEA	HE9

[Data type] Bit

HE1 to HEG The corresponding high-speed position switch is:
 0 : Enabled.
 1 : Disabled. (A disabled high-speed position switch always outputs 0.)

NOTE

The two-digit number in each parameter name corresponds to the order of the high-speed position switch.

	#7	#6	#5	#4	#3	#2	#1	#0
8508	HM8	HM7	HM6	HM5	HM4	HM3	HM2	HM1
8509	HMG	HMF	HME	HMD	HMC	HMB	HMA	HM9

[Data type] Bit

HM1 to HMG The output type of the corresponding high-speed position switch is:
 0 : Normal. (The machine coordinate range is used to determine whether to output the signal.)
 1 : Decision by direction. (The machine coordinates and operation direction are used to determine whether to output the signal.)

	#7	#6	#5	#4	#3	#2	#1	#0
8512	HA8	HA7	HA6	HA5	HA4	HA3	HA2	HA1
8513	HAG	HAF	HAE	HAD	HAC	HAB	HAA	HA9

[Input type] Parameter input

[Data type] Bit

HA1 to HAG The signal is turned on when the corresponding high-speed position switch passes through the machine coordinate position set in parameter No. 8580 to 8589 or 12221 to 12226:
 0 : In the negative (-) direction.
 1 : In the positive (+) direction.

	#7	#6	#5	#4	#3	#2	#1	#0
8516	HB8	HB7	HB6	HB5	HB4	HB3	HB2	HB1
	#7	#6	#5	#4	#3	#2	#1	#0
8517	HBG	HBF	HBE	HBD	HBC	HBB	HBA	HB9

[Data type] Bit

HB1 to HBG The signal is turned off when the corresponding high-speed position switch passes through the machine coordinate position set in parameter No. 8590 to 8599 or 12241 to 12246:

0 : In the negative (–) direction.

1 : In the positive (+) direction.

8565	High-speed position switch output address 1
------	---

[Data type] Word

[Valid data range] 1 to 126

This parameter specifies a Y signal address for outputting a high-speed position switch signal. Both ordinary and direction-sensitive high-speed position switches use the same address. The following table lists the high-speed position switches and the output addresses.

Relationships between direction-sensitive high-speed position switches and output addresses

	Output signal address	Controlled –axis number	Output type switching	Enable/disable	Maximum operating range	Effective direction for point A	Minimum operating range	Effective direction for point B
1st to 8th	Value of parameter No. 8565	8570 to 8577	8508	8504	8580 to 8587	8512	8590 to 8597	8516
9th to 16th	Value of parameter No. 8565 plus 1	8578 to 8579, 12201 to 12206	8509	8505	8588 to 8589, 12221 to 12226	8513	8598 to 8599, 12241 to 12246	8517

NOTE

- 1 The direction-sensitive high-speed position switch becomes ON at point A and OFF at point B.
- 2 The position switch does not change its state when point A or B is passed through in the direction opposite to the effective direction.

WARNING

- 1 Be sure not to use any Y signal already used in the PMC ladder with this function. If used, the machine may behave in an unexpected manner.
- 2 If you want to use high-speed position switches for multiple paths, use a different Y signal output address for each path.
- 3 The parameter for setting the point-A machine coordinate value for the direction-sensitive high-speed position switch is identical to the parameter for setting the upper limit of the operating range for the ordinary high-speed position switch. Be careful not to set the parameter incorrectly.
- 4 The parameter for setting the point-B machine coordinate value for the direction-sensitive high-speed position switch is identical to the parameter for setting the lower limit of the operating range for the ordinary high-speed position switch. Be careful not to set the parameter incorrectly.

CAUTION

- 1 Specifying a nonexistent signal address causes the high-speed position switch function to be disabled.
- 2 After setting this parameter, turn the power off then on again so that the setting will take effect.
- 3 Y signal address Y127 cannot be specified for this function.
- 4 Address output signals (Y1001 and above) on the M-NET board cannot be specified for this function.

8570	Axis corresponding to the first high-speed position switch
8571	Axis corresponding to the second high-speed position switch
8572	Axis corresponding to the third high-speed position switch
8573	Axis corresponding to the fourth high-speed position switch
8574	Axis corresponding to the fifth high-speed position switch
8575	Axis corresponding to the sixth high-speed position switch
8576	Axis corresponding to the seventh high-speed position switch
8577	Axis corresponding to the eighth high-speed position switch
8578	Axis corresponding to the ninth high-speed position switch
8579	Axis corresponding to the tenth high-speed position switch
12201	Axis corresponding to the eleventh high-speed position switch
12202	Axis corresponding to the twelfth high-speed position switch

12203	Axis corresponding to the thirteenth high-speed position switch
12204	Axis corresponding to the fourteenth high-speed position switch
12205	Axis corresponding to the fifteenth high-speed position switch
12206	Axis corresponding to the sixteenth high-speed position switch

[Data type] Byte

[Valid data range] 0 to Number of controlled axes

These parameters specify the controlled-axis numbers corresponding to each high-speed position switch function. If the current position along the corresponding axis is within a range specified by a parameter, the corresponding high-speed position switch signal is output. If the parameter value is 0, it means that the high-speed position switch function corresponding to the number is not used.

NOTE

Parameter Nos. 8576 to 8579 and 12201 to 12206 are valid only when bit 7 (EHP) of parameter No. 8500 is 1.

8580	Position where the first high-speed position switch is turned on
8581	Position where the second high-speed position switch is turned on
8582	Position where the third high-speed position switch is turned on
8583	Position where the fourth high-speed position switch is turned on
8584	Position where the fifth high-speed position switch is turned on
8585	Position where the sixth high-speed position switch is turned on
8586	Position where the seventh high-speed position switch is turned on
8587	Position where the eighth high-speed position switch is turned on
8588	Position where the ninth high-speed position switch is turned on
8589	Position where the tenth high-speed position switch is turned on
12221	Position where the eleventh high-speed position switch is turned on
12222	Position where the twelfth high-speed position switch is turned on
12223	Position where the thirteenth high-speed position switch is turned on
12224	Position where the fourteenth high-speed position switch is turned on
12225	Position where the fifteenth high-speed position switch is turned on
12226	Position where the sixteenth high-speed position switch is turned on

[Data type] 2-word

[Unit of data]

Increment system	IS-B	IS-C	Unit
Metric machine	0.001	0.0001	mm
Inch machine	0.0001	0.00001	inch
Rotation axis	0.001	0.0001	deg

[Valid data range] -99999999 to 99999999

These parameters specify the machine coordinates where each high-speed position switch becomes ON. The state of a position switch changes only when the sensor passes through the corresponding position specified in the machine coordinate system in the direction specified in parameter Nos. 8512 and 8513 (bit).

WARNING

The parameter for setting the machine coordinate value where the direction-sensitive high-speed position switch becomes ON is identical to the parameter for setting the upper limit of the operating range for the ordinary high-speed position switch. Be careful not to set the parameter incorrectly.

NOTE

Parameter Nos. 8586 to 8589 and 12221 to 12226 are valid only when bit 7 (EHP) of parameter No. 8500 is 1.

8590	Position where the first high-speed position switch is turned off
8591	Position where the second high-speed position switch is turned off
8592	Position where the third high-speed position switch is turned off
8593	Position where the fourth high-speed position switch is turned off
8594	Position where the fifth high-speed position switch is turned off
8595	Position where the sixth high-speed position switch is turned off
8596	Position where the seventh high-speed position switch is turned off
8597	Position where the eighth high-speed position switch is turned off
8598	Position where the ninth high-speed position switch is turned off
8599	Position where the tenth high-speed position switch is turned off
12241	Position where the eleventh high-speed position switch is turned on
12242	Position where the twelfth high-speed position switch is turned on
12243	Position where the thirteenth high-speed position switch is turned on

12244	Position where the fourteenth high-speed position switch is turned on
12245	Position where the fifteenth high-speed position switch is turned on
12246	Position where the sixteenth high-speed position switch is turned on

[Data type] 2-word

[Unit of data]	Increment system	IS-B	IS-C	Unit
	Metric machine	0.001	0.0001	mm
	Inch machine	0.0001	0.00001	inch
	Rotation axis	0.001	0.0001	deg

[Valid data range] -99999999 to 99999999

These parameters specify the machine coordinates where each high-speed position switch becomes OFF. The state of a position switch changes only when the sensor passes through the corresponding position specified in the machine coordinate system in the direction specified in parameter Nos. 8516 and 8517 (bit).

WARNING

The parameter for setting the machine coordinate value where the direction-sensitive high-speed position switch becomes OFF is identical to the parameter for setting the lower limit of the operating range for the ordinary high-speed position switch. Be careful not to set the parameter incorrectly.

NOTE

Parameter Nos. 8596 to 8599 and 12241 to 12246 are valid only when bit 7 (EHP) of parameter No. 8500 is 1.

1.3 ERROR COMPENSATION

1.3.1 Stored Pitch Error Compensation

General

If pitch error compensation data is specified, pitch errors of each axis can be compensated in detection units per axis.

Pitch error compensation data is set for each compensation position at the intervals specified for each axis. The origin of compensation is the reference position to which the tool is returned.

Pitch error compensation data can be set with external devices such as the Handy File (see Operator's manual). Compensation data can also be set directly with the MDI panel.

The following parameters must be set for pitch error compensation. Set the pitch error compensation value for each pitch error compensation position number set by these parameters.

In the following example, 33 is set for the pitch error compensation number at the reference position.

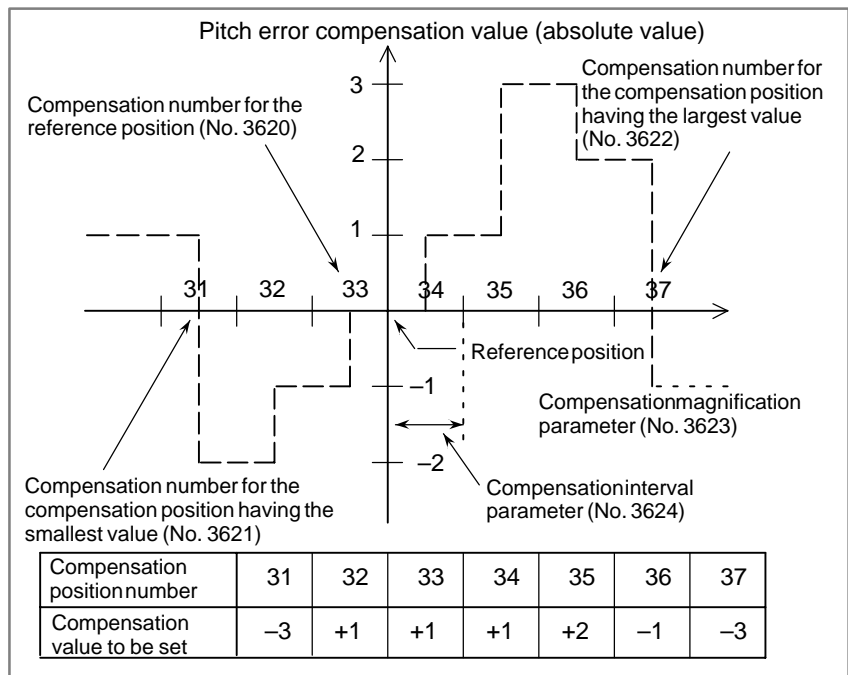



- Pitch error compensation position at the reference position (for each axis): Parameter 3620
- Pitch error compensation position having the smallest value (for each axis): Parameter 3621
- Pitch error compensation position having the largest value (for each axis): Parameter 3622
- Pitch error compensation magnification (for each axis): Parameter 3623

Procedure for displaying and setting the pitch error compensation data

- Interval of the pitch error compensation positions (for each axis): Parameter 3624

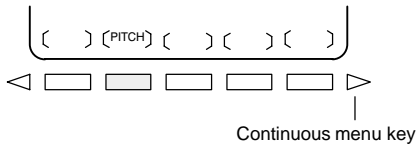
- Set the following parameters:
 - Pitch error compensation position at the reference position (for each axis): Parameter 3620
 - Pitch error compensation position having the smallest value (for each axis): Parameter 3621
 - Pitch error compensation position having the largest value (for each axis): Parameter 3622
 - Pitch error compensation magnification (for each axis): Parameter 3623
 - Interval of the pitch error compensation positions (for each axis): Parameter 3624



- Press function key **SYSTEM**.
- Press the continuous menu key , then press chapter selection soft key **[PITCH]**.







The following screen is displayed:

PIT-ERROR SETTING				0000 N00000	
NO.	DATA	NO.	DATA	NO.	DATA
0000	0	0010	0	0020	0
0001	0	0011	0	0021	0
0002	0	0012	0	0022	0
0003	0	0013	0	0023	0
(X)0004	0	0014	0	0024	0
0005	0	0015	0	0025	0
0006	0	0016	0	0026	0
0007	0	0017	0	0027	0
0008	0	0018	0	0028	0
0009	0	0019	0	0029	0

> _

MEM **** * * * * 16:05:59

[NO.SRH] [ON:1] [OFF:0] [+INPUT] [-INPUT]

- Move the cursor to the compensation position number to be set in either of the following ways:
 - Enter the compensation position number and press the **[NO.SRH]** soft key.
 - Move the cursor to the compensation position number using the page keys,  and , and cursor keys, , , , and .
- Enter a value with numeric keys and press the **[INPUT]** soft key.

Explanations

- **Specifying the compensation position**

To assign the compensation positions for each axis, specify the positive direction or the negative direction relative to the compensation position No. of the reference position. If the machine stroke exceeds the specified range on either the positive direction or the negative direction, the pitch error compensation does not apply beyond the range.

- **Compensation position number**

1024 compensation positions from No. 0 to 1023 are available on the pitch error setting screen. Assign arbitrary positions for each axis using parameters.

The number of the compensation position at the reference position (parameter 3620), number of the compensation position having the smallest value (parameter 3621), and number of the compensation position having the largest value (parameter 3622) must be set for each axis.

The name of each axis is displayed before the smallest compensation position number on the pitch error setting screen.

- **Interval of compensation positions**

The pitch error compensation positions are equally spaced to parameter No. 3624. Set the space between two adjacent positions for each axis.

The minimum interval between pitch error compensation positions is limited and obtained from the following equation:

Minimum interval of pitch error compensation positions = maximum feedrate (rapid traverse rate)/7500

Unit:

- Minimum interval of pitch error compensation positions: mm, inches, deg.
- Maximum feed rate: mm/min, inch/min, deg/min

[Example] When the maximum rapid traverse rate is 15000 mm/min, the minimum interval between pitch error compensation positions is 2 mm.

Examples

- **For linear axis**

- Machine stroke: -400 mm to +800 mm
 - Interval between the pitch error compensation positions: 50 mm
 - No. of the compensation position of the reference position: 40
- If the above is specified, the No. of the farthest compensation position in the negative direction is as follows:

$$\begin{aligned} & \text{No. of the compensation position of the reference position} - (\text{Machine stroke on the negative side} / \text{Interval between the compensation positions}) + 1 \\ & = 40 - 400/50 + 1 = 33 \end{aligned}$$

No. of the farthest compensation position in the positive direction is as follows:

$$\begin{aligned} & \text{No. of the compensation position of the reference position} + (\text{Machine stroke on the positive side} / \text{Interval between the compensation positions}) \\ & = 40 + 800/50 = 56 \end{aligned}$$

The correspondence between the machine coordinate and the compensation position No. is as follows:

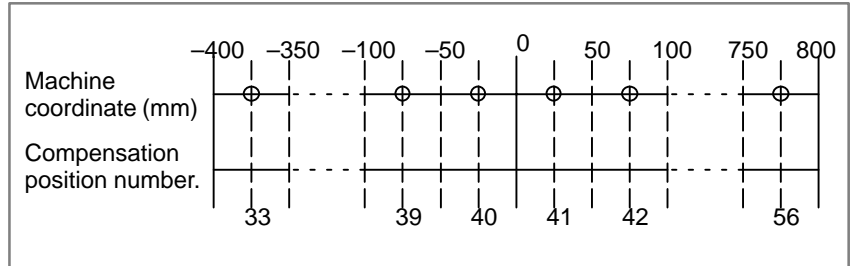

Compensation values are output at the positions indicated by ○.

Therefore, set the parameters as follows:

Parameter	Setting value
3620 : Compensation number for the reference position	40
3621 : Smallest compensation position number	33
3622 : Largest compensation position number	56
3623 : Compensation magnification	1
3624 : Interval between pitch error compensation positions	50000

The compensation amount is output at the compensation position No. corresponding to each section between the coordinates.

The following is an example of the compensation amounts.

No	33	34	35	36	37	38	39	40	41	42	43	44	45	46	47	48	49	56
Compensation value	-2	-1	-1	+2	0	+1	0	+1	+2	+1	0	-1	-1	-2	0	+1	+2	1

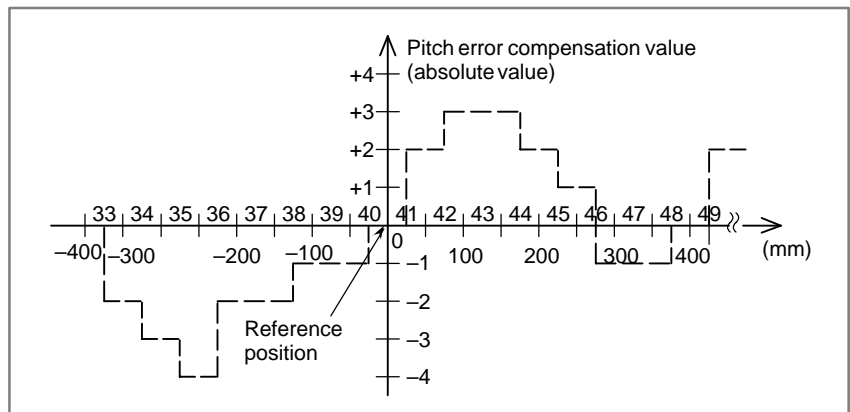

● **For rotary axis**

· Amount of movement per rotation: 360°

· Interval between pitch error compensation positions: 45°

· No. of the compensation position of the reference position: 60

If the above is specified, the No. of the farthest compensation position in the negative direction for the rotating axis is always equal to the compensation position No. of the reference position.

The No. of the farthest compensation position in the positive direction is as follows:

$$\begin{aligned} & \text{No. of the compensation position of the reference position} + (\text{Move} \\ & \text{amount per rotation} / \text{Interval between the compensation positions}) \\ & = 60 + 360/45 = 68 \end{aligned}$$

The correspondence between the machine coordinate and the compensation position No. is as follows:

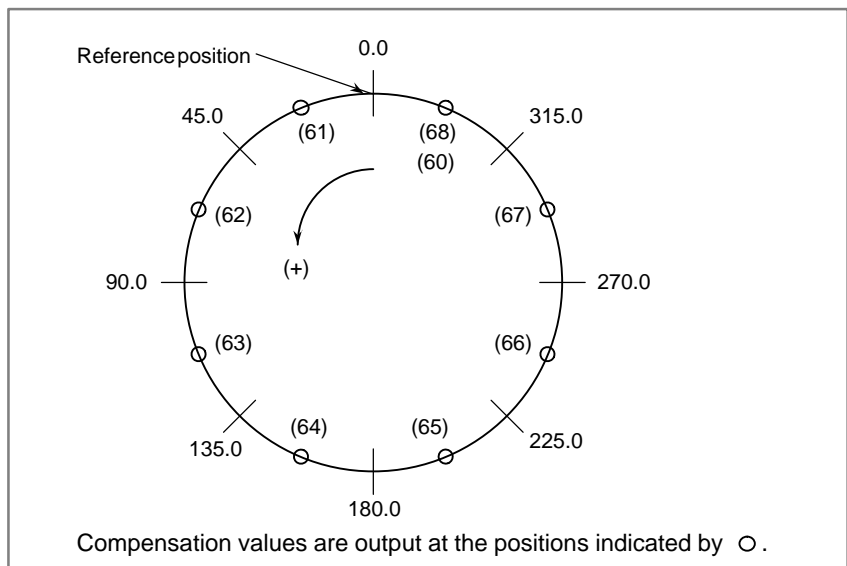

Therefore, set the parameters as follows:

Parameter	Setting value
3620 : Compensation number for the reference position	60
3621 : Smallest compensation position number	60
3622 : Largest compensation position number	68
3623 : Compensation magnification	1
3624 : Interval between pitch error compensation positions	45000
3625 : Movement value per rotation	360000

If the sum of the compensation values for positions 61 to 68 is not 0, pitch error compensation values are accumulated for each rotation, causing positional deviation.

The same value must be set for compensation positions 60 and 68.

The following is an example of compensation amounts.

No	60	61	62	63	64	65	66	67	68
Compensation value	+1	-2	+1	+3	-1	-1	-3	+2	+1

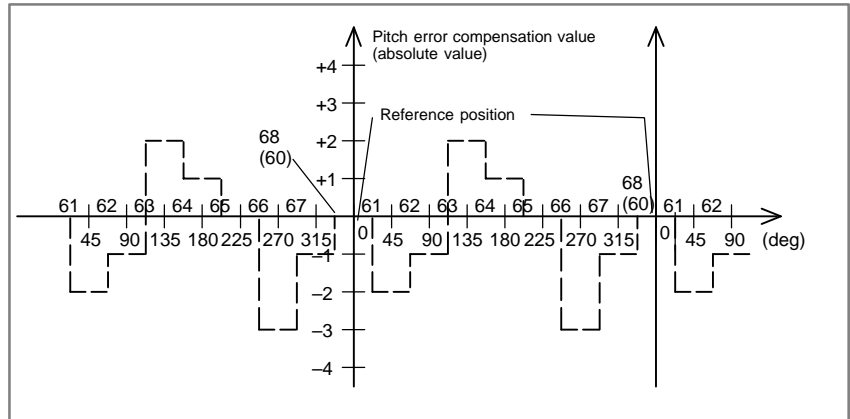

Parameter

3620	Number of the pitch error compensation position for the reference position for each axis
------	--

NOTE
After setting this parameter, turn the power off then on again so that the setting will take effect.

[Data type] Word axis

[Unit of data] Number

[Valid data range] 0 to 1023

Set the number of the pitch error compensation position for the reference position for each axis.

3621	Number of the pitch error compensation position at extreme negative position for each axis
------	--

NOTE
After setting this parameter, turn the power off then on again so that the setting will take effect.

[Data type] Word axis

[Unit of data] Number

[Valid data range] 0 to 1023

Set the number of the pitch error compensation position at the extreme negative position for each axis.

3622

Number of the pitch error compensation position at extreme positive position for each axis

NOTE

After setting this parameter, turn the power off then on again so that the setting will take effect.

[Data type] Word axis

[Unit of data] Number

[Valid data range] 0 to 1023

Set the number of the pitch error compensation position at the extreme positive position for each axis.

NOTE

This value must be larger than the value of parameter (No. 3620).

3623

Magnification for pitch error compensation for each axis

NOTE

After setting this parameter, turn the power off then on again so that the setting will take effect.

[Data type] Byte axis

[Unit of data] 1

[Valid data range] 0 to 100

Set the magnification for pitch error compensation for each axis.

If the magnification is set to 1, the magnification is the same as the detection unit.

3624

Interval between pitch error compensation positions for each axis

NOTE

After setting this parameter, turn the power off then on again so that the setting will take effect.

[Data type] Two-word axis

[Unit of data]	Increment system	IS-A	IS-B	IS-C	Unit
	Metric machine	0.01	0.001	0.0001	mm
	Inch machine	0.001	0.0001	0.00001	inch
	Rotation axis	0.01	0.001	0.0001	deg

[Valid data range] 0 to 99999999

The pitch error compensation positions are equally spaced to parameter No. 3624. Set the space between two adjacent positions for each axis.

The minimum interval between pitch error compensation positions is limited and obtained from the following equation:

Minimum interval of pitch error compensation positions = maximum feedrate (rapid traverse rate)/7500

Unit:

- Minimum interval of pitch error compensation positions: mm, inches, deg.
- Maximum feed rate: mm/min, inch/min, deg/min

[Example] When the maximum rapid traverse rate is 15000 mm/min, the minimum interval between pitch error compensation positions is 2 mm.

3625

Travel distance per revolution in pitch error compensation of rotation axis type
--

NOTE

When this parameter has been set, the power must be turned off before operation is continued.

[Data type] 2-word axis

[Valid data range] 0 to 99999999

If the pitch error compensation of rotation axis type is performed (bit 1 (ROSx) of parameter No. 1006 is set to 0 and bit 0 (ROTx) of parameter No. 1006 is set to 1), set the travel distance per revolution. The travel distance per revolution does not have to be 360 degrees, and a cycle of pitch error compensation of rotation axis type can be set.

However, the travel distance per revolution, compensation interval, and number of compensation points must satisfy the following condition:

$$(\text{Travel distance per revolution}) = (\text{Compensation interval}) \times (\text{Number of compensation points})$$

The compensation at each compensation point must be set so that the total compensation per revolution equals 0.

NOTE

- 1 If 0 is set, the travel distance per revolution becomes 360 degrees.
- 2 If the value excluding 360-degrees (include 0) is set, set the same value for both parameter No.3625 and parameter No.1260.

Warning

WARNING

1 Compensation value range

Compensation values can be set within the range from $-7 \times$ compensation magnification (detection unit) to $+7 \times$ compensation magnification (detection unit). The compensation magnification can be set for each axis within the range from 0 to 100 in parameter 3623.

2 Pitch error compensation of the rotary axis

For the rotating axis, the interval between the pitch error compensation positions shall be set to one per integer of the amount of movement (normally 360°) per rotation. The sum of all pitch error compensation amounts per rotation must be made to 0. Also, set the same compensation value to a position and the same position with one rotation.

3 Conditions where pitch error compensation is not performed

Note that the pitch error is not compensated in the following cases:

- When the machine is not returned to the reference position after turning on the power. This excludes the case where an absolute position detector is employed.
- If the interval between the pitch error compensation positions is 0.
- If the compensation position Nos. on the positive or negative direction do not fall within the range of 0 to 1023.
- If the compensation position Nos. do not conform to the following relationship:

Negative side \leq Reference position $<$ Positive side

Reference item

Series 16 <i>i</i> /18 <i>i</i> /160 <i>i</i> /180 <i>i</i> / 160 <i>s</i> /180 <i>s</i>	OPERATOR'S MANUAL (For Machining Center) (B-63534EN)	III.8.6.3	Inputting pitch error compensa- tion data
		III.8.6.4	Outputting pitch error com- pensation data
		III.11.5.2	Displaying and setting pitch error compensation data
	OPERATOR'S MANUAL (For Lathe) (B-63524EN)	III.8.6.3	Inputting pitch error compensa- tion data
		III.8.6.4	Outputting pitch error com- pensation data
		III.11.5.2	Displaying and setting pitch error compensation data
Series 21 <i>i</i> /210 <i>i</i> /210 <i>s</i>	OPERATOR'S MANUAL (For Machining Center) (B-63614EN)	III.8.6.3	Inputting pitch error compensa- tion data
		III.8.6.4	Outputting pitch error com- pensation data
		III.11.5.2	Displaying and setting pitch error compensation data
	OPERATOR'S MANUAL (For Lathe) (B-63604EN)	III.8.6.3	Inputting pitch error compensa- tion data
		III.8.6.4	Outputting pitch error com- pensation data
		III.11.5.2	Displaying and setting pitch error compensation data
Series 20 <i>i</i>	OPERATOR'S MANUAL (For Manual Milling Machine) (B-64204EN)	III.8.6.3	Inputting pitch error compensa- tion data
		III.8.6.4	Outputting pitch error com- pensation data
		III.13.5.2	Displaying and setting pitch error compensation data
	OPERATOR'S MANUAL (For Manual Lathes) (B-64194EN)	III.8.6.3	Inputting pitch error compensa- tion data
		III.8.6.4	Outputting pitch error com- pensation data
		III.13.5.2	Displaying and setting pitch error compensation data

1.3.2 Backlash Compensation

General

- Backlash compensation** Function for compensating for lost motion on the machine. Set a compensation value in parameter No. 1851, in detection units from 0 to ± 9999 pulses for each axis.
- Backlash compensation for each rapid traverse and cutting feed** More precise machining can be performed by changing the backlash compensating value depending on the feedrate, the rapid traverse or the cutting feed.

Let the measured backlash at cutting feed be A and the measured backlash at rapid traverse be B. The backlash compensating value is shown below depending on the change of feedrate (cutting feed or rapid traverse) and the change of the direction of movement.

Change of feedrate Change of direction of movement	Cutting feed to cutting feed	Rapid traverse to rapid traverse	Rapid traverse to cutting feed	Cutting feed to rapid traverse
Same direction	0	0	$\pm \alpha$	$\pm (-\alpha)$
Opposite direction	$\pm A$	$\pm B$	$\pm (B+\alpha)$	$\pm (B+\alpha)$

- $\alpha = (A-B)/2$
- The positive or negative direction for compensating values is the direction of movement.

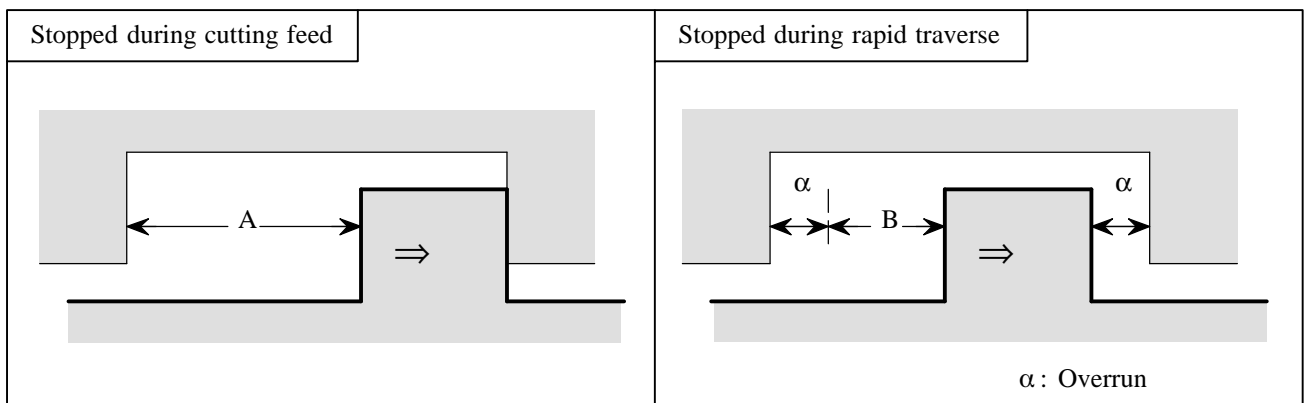

- Assign the measured backlash at cutting feed (A) in parameter No. 1851 and that at rapid traverse (B) in parameter No. 1852.

Parameter

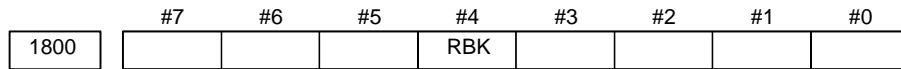

[Data type] Bit

RBK Backlash compensation applied separately for cutting feed and rapid traverse
 0 : Not performed
 1 : Performed

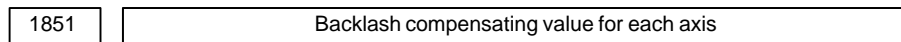

[Data type] Word axis

[Unit of data] Detection unit

[Valid data range] -9999 to +9999

Set the backlash compensating value for each axis.
 When RBK is 1, set the backlash compensating value for cutting feed.
 When the machine moves in the opposite direction from to the reference position return direction after the power is turned on, the first backlash compensation is performed.

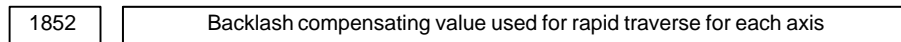

[Data type] Word axis

[Unit of data] Detection unit

[Valid data range] -9999 to +9999

Set the backlash compensating value used in rapid traverse for each axis.
 This parameter is valid when RBK is set to 1.

Caution

CAUTION
 The backlash compensation for rapid traverse and cutting feed is not performed until the first reference position return is completed after the power is turned on. Under this state, the normal backlash compensation is performed according to the value specified in parameter No. 1851 irrespective of a rapid traverse or a cutting feed.

Note

NOTE
 When backlash compensation is applied separately for cutting feed and rapid traverse, jog feed is regarded as cutting feed.

1.3.3 Straightness Compensation

General

For a machine tool with a long stroke, deviations in straightness between axes may affect the machining accuracy. For this reason, when an axis moves, other axes are compensated in detection units to improve straightness. This improvement results in better machining accuracy. When an axis (parameter Nos. 5711 to 5713) moves, the corresponding compensation axis (parameter Nos. 5721 to 5723) is compensated. That is, the compensation axis is compensated at the pitch error compensation position (See 1.3.1) of the moving axis.

Example

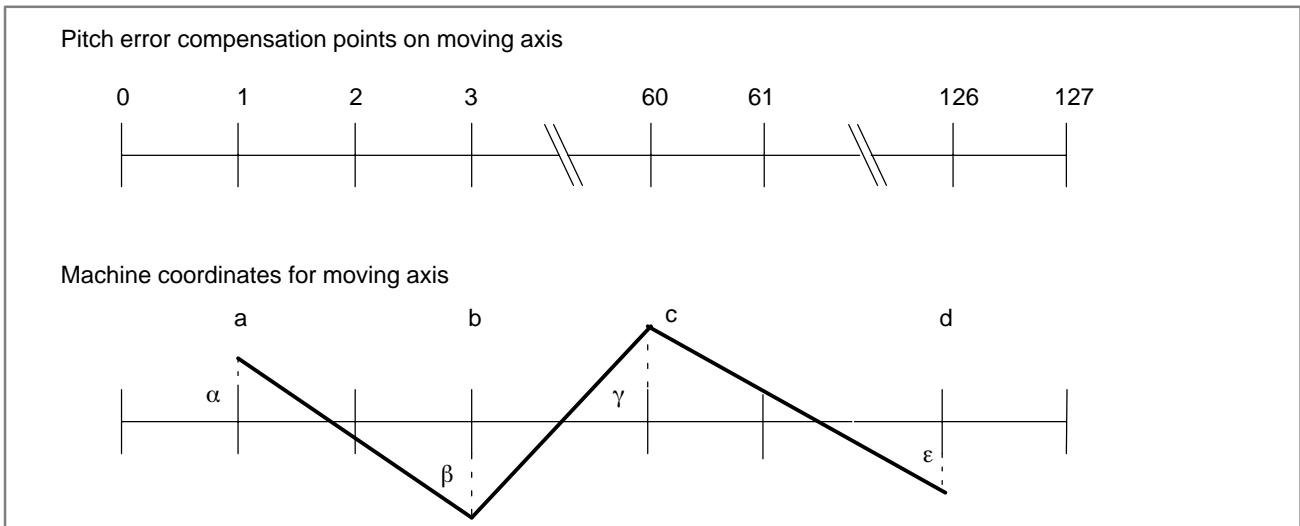

- a, b, c, d Compensation position numbers of the moving axis
(This number is originally a pitch error compensation position number.)
- α , β , γ , ϵ Compensation for compensation axis
Compensation amount for the compensation position number

The compensation from point a to point b is calculated from the formula:
 $(\beta - \alpha) / (b - a)$.

Example

Imagine a table whose Y-axis ball screw is placed on its X-axis ball screw. If the X-axis ball screw is inclined at a certain angle because of, for example, bending, the machining precision related to the Y-axis becomes low because its ball screw is affected by the gradient of the X-axis ball screw. (See Fig. 1.3.3 (a).)

Specifying the X-axis and Y-axis, respectively, as a moving axis and a compensation axis by means of straightness compensation causes the Y-axis (compensation axis) position to be compensated according to the X-axis (moving axis) position, thus increasing the machining precision. (See Fig. 1.3.3 (b).)

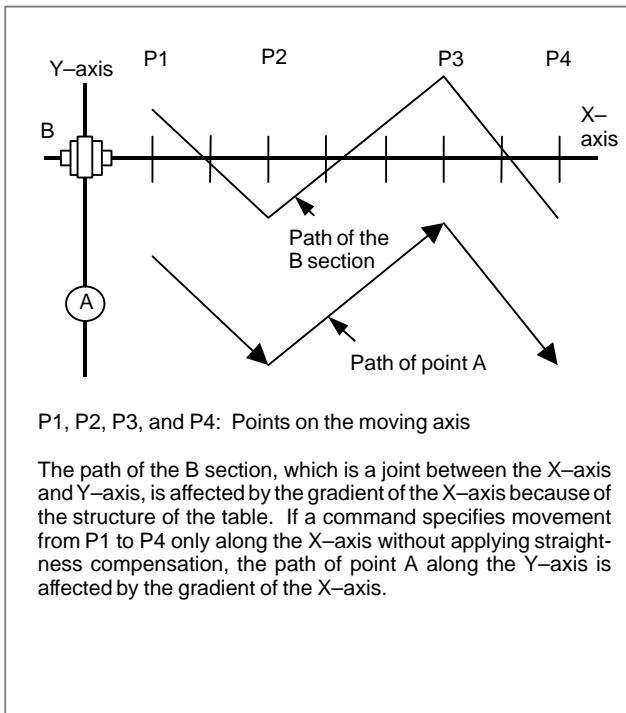

Fig. 1.3.3 (a)

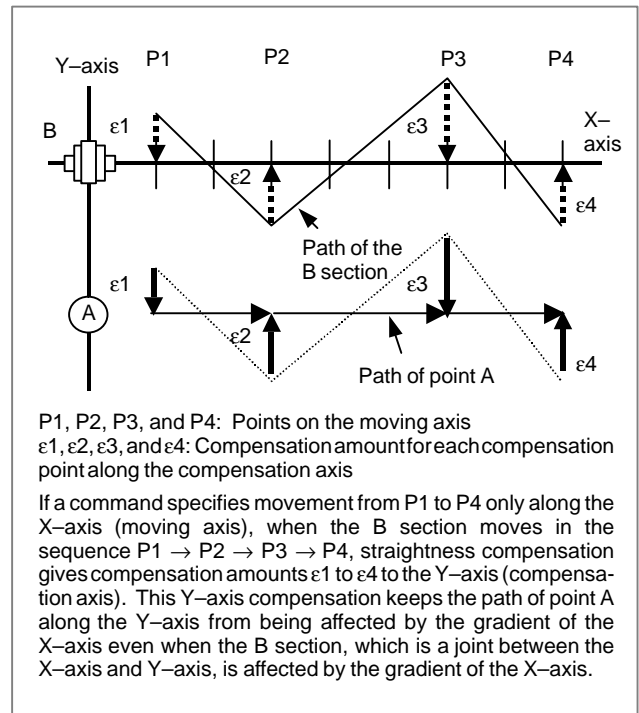

Fig. 1.3.3 (b)

Parameter

5711	Axis number of moving axis 1
5712	Axis number of moving axis 2
5713	Axis number of moving axis 3

[Data type] Byte

[Unit of data] Axis number (When 0, compensation is not performed.)

[Valid data range] 1 to Number of controlled axes

Set the axis numbers of moving axes.

5721	Axis number of compensation axis 1 for moving axis 1
5722	Axis number of compensation axis 2 for moving axis 2
5723	Axis number of compensation axis 3 for moving axis 3

[Data type] Byte

[Unit of data] Axis number (When 0, compensation is not performed.)

[Valid data range] 1 to Number of controlled axes

Set the axis numbers of compensation axes.

5731	Compensation position number a of moving axis 1
5732	Compensation position number b of moving axis 1
5733	Compensation position number c of moving axis 1
5734	Compensation position number d of moving axis 1
5741	Compensation position number a of moving axis 2
5742	Compensation position number b of moving axis 2
5743	Compensation position number c of moving axis 2
5744	Compensation position number d of moving axis 2
5751	Compensation position number a of moving axis 3
5752	Compensation position number b of moving axis 3
5753	Compensation position number c of moving axis 3
5754	Compensation position number d of moving axis 3

[Data type] Word

[Unit of data] Number

(Compensation position numbers in stored pitch error compensation)

[Valid data range] 0 to 1023

Set four compensation positions for each moving axis.

5761	Compensation corresponding to compensation position number a of moving axis 1
5762	Compensation corresponding to compensation position number b of moving axis 1
5763	Compensation corresponding to compensation position number c of moving axis 1
5764	Compensation corresponding to compensation position number d of moving axis 1
5771	Compensation corresponding to compensation position number a of moving axis 2
5772	Compensation corresponding to compensation position number b of moving axis 2
5773	Compensation corresponding to compensation position number c of moving axis 2
5774	Compensation corresponding to compensation position number d of moving axis 2
5781	Compensation corresponding to compensation position number a of moving axis 3
5782	Compensation corresponding to compensation position number b of moving axis 3
5783	Compensation corresponding to compensation position number c of moving axis 3
5784	Compensation corresponding to compensation position number d of moving axis 3

[Data type] Word

[Unit of data] Detection unit

[Valid data range] -32768 to +32767

Set compensation for each compensation position.

Alarm and message

Number	Message	Description
5046	ILLEGAL PARAMETER (ST. COMP)	<p>Parameters related to straightness compensation have been erroneously specified. Possible causes are as follows:</p> <ol style="list-style-type: none"> 1. Invalid axis numbers have been assigned to move or compensation axes. 2. The number of pitch-error compensation positions between the maximum positive and maximum negative positions exceeds 128. 3. Straightness compensation position numbers have been assigned in other than ascending order. 4. Straightness compensation positions could not be located between the maximum positive and maximum negative pitch-error compensation positions. 5. The amount of compensation per compensation position is too large or too small.

Note**NOTE**

- 1 The straightness compensation function can be used after a moving axis and its compensation axis have returned to the reference position.
- 2 After setting parameters for straightness compensation, be sure to turn off the NC power.
- 3 Set parameters for straightness compensation according to the following conditions:
 - The compensation at a compensation position must be within the range -128 to 127 .
 - Compensation positions must be set so that " $a \leq b \leq c \leq d$ " is satisfied.
 - Compensation positions must exist between the compensation position with the largest positive value and that with the largest negative value in the stored pitch error compensation data for each axis. Four compensation positions can be set to 0 at a time. In this case, compensation is not performed.
- 4 To add the straightness compensation function option, the stored pitch error compensation option is needed.
In this case, the number of compensation positions of each axis between the compensation position with the largest positive value and that with the largest negative value in the stored pitch error compensation data must be equal to or less than 128.
- 5 Straightness compensation data is superposed on stored pitch error compensation data and output.
Straightness compensation is performed at pitch error compensation intervals.
- 6 Straightness compensation does not allow the moving axis to be used as a compensation axis. To implement such compensation, use gradient compensation (see Subsection 1.3.4, "Gradient Compensation").

**1.3.4
Gradient
Compensation****Overview**

By compensating for those errors in tools such as feed screws that depend on the position of the machine system in detection units, machining precision can be improved and mechanical life can be prolonged. Compensation is performed along an approximate straight line formed with a parameter-specified compensation point and a compensation amount related to it.

Specification

Three approximate straight lines are formed with four parameter-specified compensation points and compensation amounts related to the respective compensation points. Gradient compensation is carried out along these approximate straight lines at pitch error compensation intervals. The gradient compensation amount is added to the pitch error compensation amount.

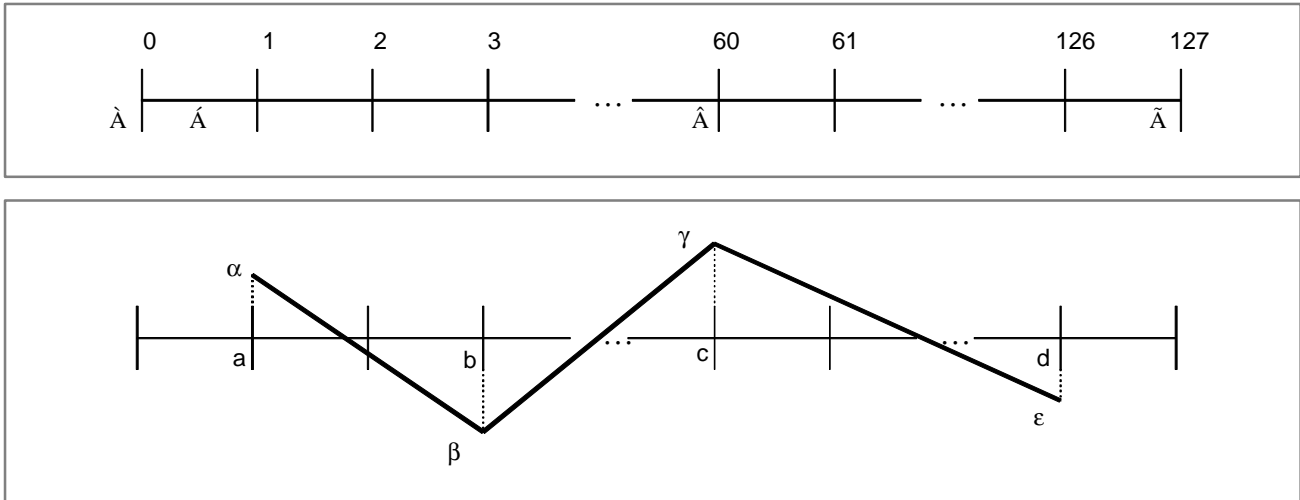

Fig. 1.3.4

To perform gradient compensation, stored pitch error compensation must be set for the axis subject to compensation.

- (1) Number of the most distant pitch error compensation point on the – side (parameter No.3621)
- (2) Pitch error compensation point interval (parameter No. 3624)
- (3) Number of the pitch error compensation point of the reference position (parameter No. 3620)
- (4) Number of the most distant pitch error compensation point on the + side (parameter No. 3623)

Gradient compensation parameters must be set.

a, b, c, d: Compensation point numbers. (Pitch error compensation point numbers are used. Parameters Nos. 5861 to 5864)

α, β, γ, ε: Compensation amounts at compensation points a, b, c, and d (parameters Nos. 5871 to 5874)

In Fig. 1.3.4, a, b, c, and d are 1, 3, 60, and 126, respectively.

Unlike stored pitch error compensation, whose amount is set up for an individual compensation point, an amount of gradient compensation is calculated for individual compensation points by setting up four typical points and compensation amounts for them.

Example: In Fig. 1.3.4, the compensation amounts at the individual compensation points located between points a and b are $(\beta-\alpha)/(b-a)$.

Parameter

5861	Compensation point number a for each axis
5862	Compensation point number b for each axis
5863	Compensation point number c for each axis
5864	Compensation point number d for each axis

[Data type] Word axis

[Unit of data] Number

[Valid data range] 0 to 1023

These parameters set the compensation points for gradient compensation. The points are set for the compensation point numbers for stored pitch error compensation.

5871	Compensation α at compensation point number a for each axis
5872	Compensation β at compensation point number b for each axis
5873	Compensation γ at compensation point number c for each axis
5874	Compensation ϵ at compensation point number d for each axis

[Data type] Word axis

[Unit of data] Detection unit

[Valid data range] -32767 to 32767

These parameters set compensation for each compensation point.

If pitch error compensation is applied at the same compensation point, the valid data range is narrowed by the amount of compensation.

Alarm and message

Number	Message	Contents
5218	ILLEGAL PARAMETER (I-COMP.)	<p>The parameter for setting slope compensation is incorrect.</p> <p>This alarm occurs in the following cases:</p> <ul style="list-style-type: none"> • When the number of pitch error compensation points on the axis on which slope compensation is executed exceeds 128 between the most negative side and most positive side • When the size relationship between the slope compensation point Nos. is incorrect • When the slope compensation point is not located between the most negative side and most positive side of pitch error compensation • When the compensation per compensation point is too small or too great.

Note**NOTE**

- 1 Gradient compensation is enabled after the reference position is established on the compensation axis.
- 2 When the parameters No.5861 – No.5864 (compensation point number a – d for each axis) are set, turn the NC off then back on.
When the parameters No.5871 – No.5874 (compensation value at compensation point number a – d for each axis) are changed, the compensation amounts, which are calculated from the changed compensation values, are outputted after crossing the next gradient compensation amount outputting points.
- 3 Parameters must satisfy the following conditions:
 - The compensation amount at a compensation point must be in the range of –128 to 127.
 - Compensation points must satisfy the following relationships: $a \leq b \leq c \leq d$.
 - Compensation points must be located between the most distant compensation point in stored pitch error compensation on the – side of each axis and the most distant compensation point on the + side. If all four points are equal to 0, compensation is not performed.
- 4 To add the gradient compensation function option, the stored pitch error compensation function option is required. The number of compensation points located between the most distant compensation point on the + side of each axis and the most distant compensation point on the – side in stored pitch error compensation must not exceed 128.
- 5 Gradient compensation is superimposed on the stored pitch error compensation data.
- 6 This function is applied to both linear and rotation axes.

1.3.5 Bidirectional Pitch Error Compensation

Outline

In bidirectional pitch error compensation, different pitch error compensation amounts can be set for travel in the positive direction and that in the negative direction, so that pitch error compensation can be performed differently in the two directions, in contrast to stored pitch error compensation, which does not distinguish between the directions of travel. In addition, when the direction of travel is reversed, the compensation amount is automatically calculated from the pitch error compensation data to perform compensation in the same way as in backlash compensation. This reduces the difference between the paths in the positive and negative directions.

Setting data

1. Setting parameters

Set the following parameters for each axis.

Table 1.3.5 (a)

Data number	Description
3605#0	Bidirectional pitch error compensation, 1: Enabled / 0: Disabled
3620	Number of the pitch error compensation point of the reference position
3621	Number of the most distant pitch error compensation point on the - side for travel in the positive direction
3622	Number of the most distant pitch error compensation point on the + side for travel in the positive direction
3623	Pitch error compensation magnification
3624	Pitch error compensation point interval
3625	For a rotation axis, amount of travel per rotation in pitch error compensation
3626	Number of the most distant pitch error compensation point on the - side for travel in the negative direction
3627	Pitch error compensation amount (absolute value) at the reference position when the machine moves to the reference position in the direction opposite to that of a reference position return

2. Pitch error compensation data

The compensation point numbers can be from 0 to 1023 and from 3000 to 4023. This data may be used for both the positive and negative directions. Note, however, that the set of compensation data for a given axis cannot extend over 1023 and 3000.

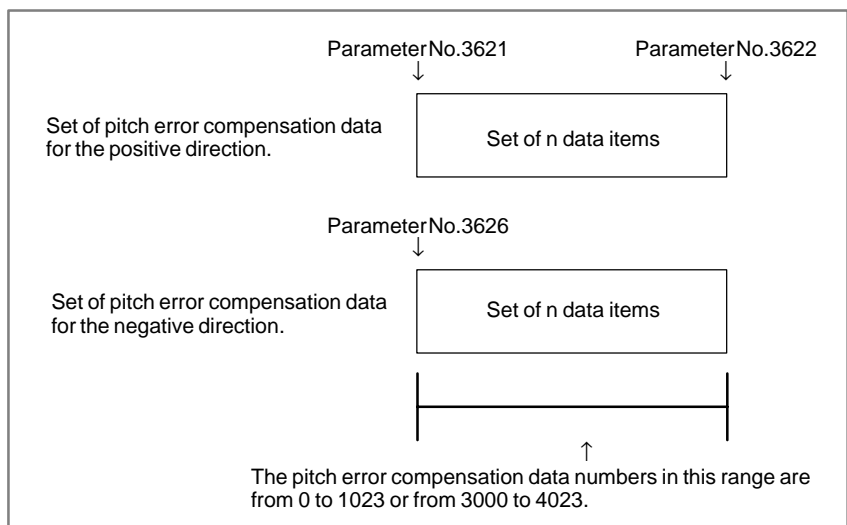

Fig. 1.3.5 (a)

Data setting example

If the direction of a manual reference position return is positive on an axis (linear axis) having the pitch error amounts shown in the figure below (Fig. 1.3.5 (b)), set the data given in the table below (Table 1.3.5 (b)).

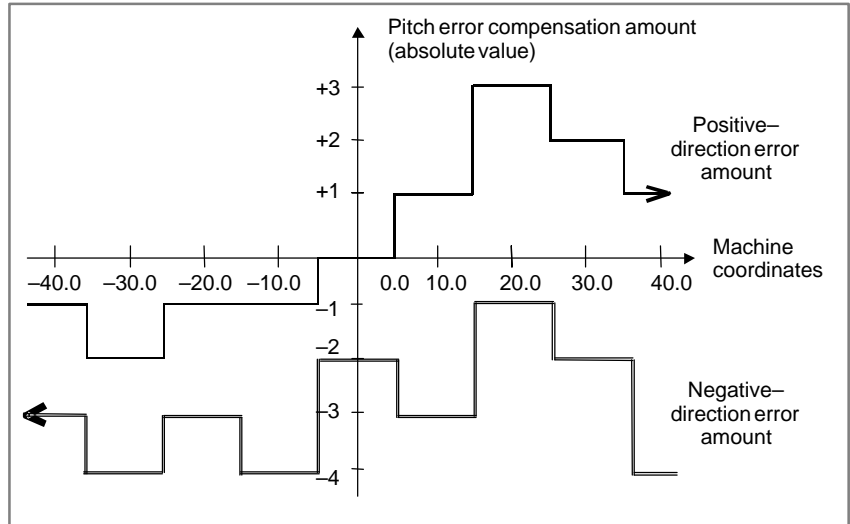

Fig. 1.3.5 (b)

Table 1.3.5 (b) Positive-direction pitch error data

Compensation point number	20	21	22	23	24	25	26	27
Compensation amount to be set	-1	+1	0	+1	+1	+2	-1	-1

As pitch error data, always set incremental values as viewed in the negative direction (direction toward the left in Fig. 1.3.5 (b)).

Table 1.3.5 (c) Negative-direction pitch error data

Compensation point number	30	31	32	33	34	35	36	37
Compensation amount to be set	-1	+1	-1	+2	-1	+2	-1	-2

Set negative-direction pitch error data for all the points for which positive-direction pitch error data has been set.

As negative-direction pitch error data, always set incremental values as viewed in the negative direction.

Table 1.3.5 (d)

Data number	Setting	Description
3605#0	1	Bidirectional pitch error compensation, 1: Enabled / 0: Disabled
3620	23	Number of the pitch error compensation point for the reference position
3621	20	Number of the most distant pitch error compensation point on the – side for travel in the positive direction
3622	27	Number of the most distant pitch error compensation point on the + side for travel in the positive direction
3623	1	Pitch error compensation magnification
3624	10000	Pitch error compensation point interval
3625	–	For a rotation axis, amount of travel per rotation in pitch error compensation
3626	30	Number of the most distant pitch error compensation point on the – side for travel in the negative direction
3627	–2	Pitch error compensation amount (absolute value) at the reference position when the machine moves to the reference position in the direction opposite to that of the reference position return

This example assumes that the direction of a manual reference position return is positive. For parameter No. 3627, therefore, set –2, which is the pitch error compensation amount (absolute value) at the reference position when the machine moves to the reference position in the negative direction.

Compensation example

If, in the setting example given in the previous section, the machine moves

- 0.0 to 40.0,
- 40.0 to -40.0, and
- 40.0 to 0.0

for a manual reference position return, pitch error compensation pulses are output as follows:

Machine coordinate	0.0	5.0	15.0	25.0	35.0	40.0
Compensation pulse	-	-1	-2	+1	+1	+5

Machine coordinate	35.0	25.0	15.0	5.0	-5.0	-15.0	-25.0	-35.0	-40.0
Compensation pulse	-2	-1	+2	-1	+2	-1	+1	-1	-2

Machine coordinate	-35.0	-25.0	-15.0	-5.0	0.0
Compensation pulse	+1	-1	0	-1	-

When the travel direction changes from positive to negative at the position of 40.0, the compensation for the reverse of the travel direction is output.

A pulse of +5 is the result of the following calculation:

$$+5 = - ((-4) - (+1))$$

Pitch error associated with the positive-direction absolute value at the position of 40.0

Pitch error associated with the negative-direction absolute value at the position of 40.0

When the travel direction changes from negative to positive at the position of -40.0, the compensation for the reverse of the travel direction is output.

A pulse of -2 is the result of the following calculation:

$$-2 = - ((-1) - (-3))$$

Pitch error associated with the negative-direction absolute value at the position of -40.0

Pitch error associated with the positive-direction absolute value at the position of -40.0

Setting and displaying data

All the compensation data can be displayed and set on the conventional screen for the pitch error compensation data.

And those data can be input and output by the following methods.

- * Input by MDI
- * Input by G10
- * Input and output by input/output device interface
- * Input by PMC window (function code 18)
(It is not possible to input and output by the method other than the above methods.)

Output format : The output format is as follows:

N20000 P... ;
 N21023 P... ;
 N23000 P... ;
 N24023 P... ;
 N : Pitch error compensation point No. + 20000
 P : Pitch error compensation data

Parameter

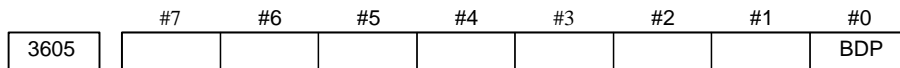

[Data type] Bit axis

BDP Specifies whether to use bidirectional pitch error compensation.

- 0 : Do not use.
- 1 : Use.

NOTE

When this parameter is set, the power must be turned off before operation is continued.

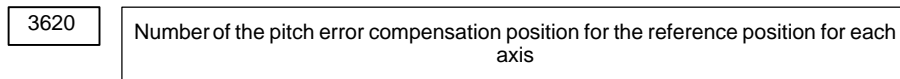

[Data type] Word axis

[Unit of data] Number

[Valid data range] 0 to 1023, 3000 to 4023

Set the number of the pitch error compensation position for the reference position for each axis

NOTE

When this parameter is set, the power must be turned off before operation is continued.

3621

Number of the pitch error compensation position at extremely negative position for each axis (In case of positive-direction movement)

[Data type] Word axis

[Unit of data] Number

[Valid data range] 0 to 1023, 3000 to 4023

Set the number of the pitch error compensation position at the extremely negative position for each axis.

NOTE

When this parameter is set, the power must be turned off before operation is continued.

3622

Number of the pitch error compensation position at extremely positive position for each axis (In case of positive-direction movement)

[Data type] Word axis

[Unit of data] Number

[Valid data range] 0 to 1023, 3000 to 4023

Set the number of the pitch error compensation position at the extremely positive position for each axis.

NOTE

When this parameter is set, the power must be turned off before operation is continued.

3623

Magnification for pitch error compensation for each axis

[Data type] Byte axis

[Unit of data] 1

[Valid data range] 0 to 100

Set the magnification for pitch error compensation for each axis. If the magnification is set to 1, the same unit as the detection unit is used for the compensation data. If the magnification is set to 0, the pitch error compensation is not valid.

NOTE

When this parameter is set, the power must be turned off before operation is continued.

3624

Interval between pitch error compensation positions for each axis

[Data type] 2-word axis

[Unit of data]	Increment system	IS-A	IS-B	IS-C	Unit
	Metric machine	0.01	0.001	0.0001	mm
	Inch machine	0.001	0.0001	0.00001	inch
	Rotation axis	0.01	0.001	0.0001	deg

[Valid data range] 0 to 99999999

The pitch error compensation positions are arranged with equal spacing. The space between two adjacent positions is set for each axis. The minimum interval between pitch error compensation positions is limited and obtained from the following equation:

$$\text{Minimum interval between pitch error compensation positions} = \frac{\text{Maximum feedrate (rapid traverse rate)}}{7500}$$

Units: Minimum interval between pitch error compensation positions:
mm, inch, deg
Maximum feedrate : mm/min, inch/min, deg/min

NOTE

When this parameter is set, the power must be turned off before operation is continued.

3625

Angular displacement per rotation in rotation-axis pitch error compensation

[Data type] 2-word axis

[Unit of data]	Increment system	IS-A	IS-B	IS-C	Unit
	Rotation axis	0.01	0.001	0.0001	deg

[Valid data range] 0 to 99999999

For rotation-axis pitch error compensation (with bit 0 (ROT) of parameter No. 1006 set to 1 and bit 1 (ROS) of parameter No.1006 set to 0), set angular displacement per rotation for each axis. The angular displacement per rotation need not always be 360 degrees. The period in rotation-axis pitch error compensation can be set.

The angular displacement per rotation, compensation interval, and number of compensation points must satisfy the following equation:

$$\text{Angular displacement per rotation} = \text{compensation interval} \times \text{number of compensation points}$$

The sum of the compensation values per rotation must always be 0. When this parameter is set to 0, it assumes that 360 degree is set.

NOTE

When this parameter is set, the power must be turned off before operation is continued.

3626

Number of the pitch error compensation position at extremely negative position for each axis (In case of negative-direction movement)

[Data type] Word axis

[Unit of data] Number

[Valid data range] 0 to 1023, 3000 to 4023

When using bidirectional pitch error compensation, set the number of the pitch error compensation position at the extremely negative position for each axis in the case of negative-direction movement.

NOTE

When this parameter is set, the power must be turned off before operation is continued.

3627

Pitch error compensation value at the reference position when a movement is made to the reference position in the direction opposite to the reference position return direction

[Data type] Word axis

[Unit of data] Detection unit

[Valid data range] -32768 to 32767

By using an absolute value, set a pitch error compensation value at the reference position when a movement is made to the reference position in the negative direction if the reference position return direction (bit 5 (ZMI) of parameter No. 1006) is positive, or when a movement is made to the reference position in the positive direction if the reference position return direction is negative.

NOTE

When this parameter is set, the power must be turned off before operation is continued.

Note

- (1) To use this function, the stored pitch error compensation option is required.
- (2) This function is enabled after a manual reference position return or an automatic reference position return with the same sequence as that of a manual reference position return is performed. When an absolute position detector is used, however, the function is enabled after the power is turned on.
- (3) When the machine moves to the reference position in the reference position return direction, set the absolute value of the pitch error compensation pulse to 0.
- (4) When this function and backlash compensation are used at the same time, the pulse resulting from backlash compensation is superimposed on the compensation pulse when the travel direction is reversed.

- (5) When this function is used for a rotation axis, the sum of the pitch error compensation amounts per rotation about the rotation axis must be 0 for both the positive and negative directions.
- (6) The function cannot be used with the inclination compensation function.
- (7) The function cannot be used with the distance coded linear scale function.

1.3.6 Extended Bidirectional Pitch Error Compensation

Outline

In bidirectional pitch error compensation, it is possible to use 0 – 1023, 3000 – 4023 points as the compensation points. By using this function, the compensation points are extended and it is possible to use 0 – 2559, 3000 – 5559 points as the compensation points.

Note

- (1) To use this function, the bidirectional pitch error compensation option is required.
- (2) The handling of this function is same as usual bidirectional pitch error compensation.
- (3) The compensation point numbers can be from 0 to 2559 and from 3000 to 5559. This data may be used for both the positive and negative directions. Note, however, that the set of compensation data for a given axis cannot extend over 2559 and 3000.

Parameter

In the case that this function is available, the valid ranges of the following parameters are extended.

3620

Number of the pitch error compensation position for the reference position for each axis
--

NOTE

When this parameter is set, the power must be turned off before operation is continued.

[Data type] Word axis

[Unit of data] Number

[Valid data range] 0 to 2559, 3000 to 5559

Set the number of the pitch error compensation position for the reference position for each axis

3621

Number of the pitch error compensation position at extremely negative position for each axis (In case of positive-direction movement)

NOTE

When this parameter is set, the power must be turned off before operation is continued.

[Data type] Word axis

[Unit of data] Number

[Valid data range] 0 to 2559, 3000 to 5559

Set the number of the pitch error compensation position at the extremely negative position for each axis.

3622

Number of the pitch error compensation position at extremely positive position for each axis (In case of positive-direction movement)

NOTE

When this parameter is set, the power must be turned off before operation is continued.

[Data type] Word axis

[Unit of data] Number

[Valid data range] 0 to 2559, 3000 to 5559

Set the number of the pitch error compensation position at the extremely positive position for each axis.

NOTE

This value must be larger than the value of parameter (No. 3620).

3626

Number of the pitch error compensation position at extremely negative position for each axis (In case of negative-direction movement)

NOTE

When this parameter is set, the power must be turned off before operation is continued.

[Data type] Word axis

[Unit of data] Number

[Valid data range] 0 to 2559, 3000 to 5559

When using bidirectional pitch error compensation, set the number of the pitch error compensation position at the extremely negative position for each axis in the case of negative-direction movement.

1.3.7 Interpolation Type Pitch Error Compensation

Outline

In stored pitch error compensation, the pitch error compensation pulse at each pitch error compensation point is output in the interval between that point and the next compensation point, as shown in the figure below.

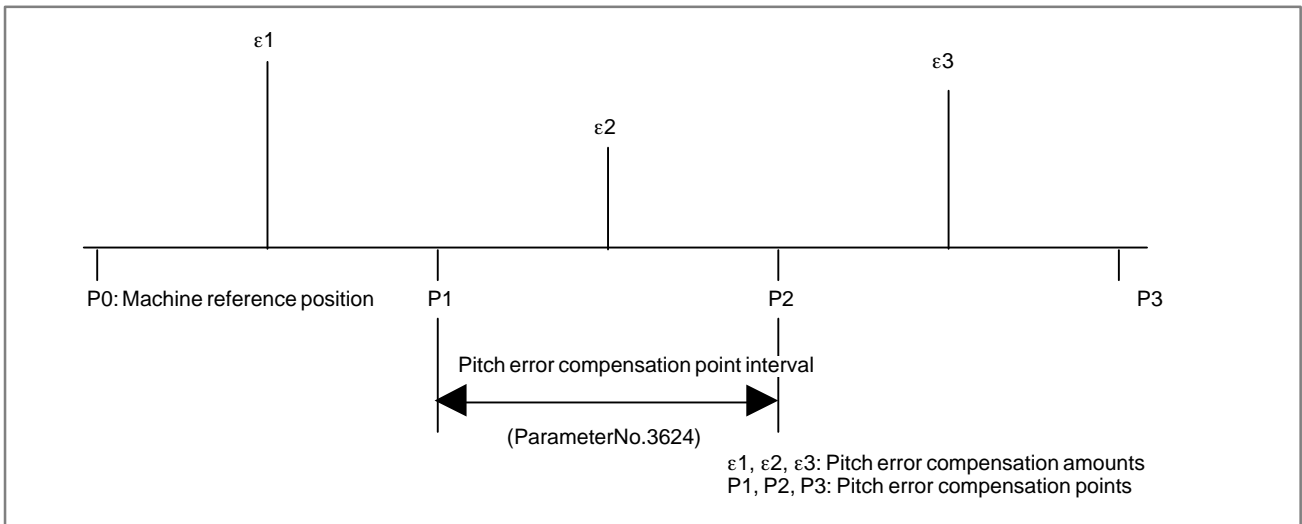

Fig. 1.3.7(a) Stored Pitch Error Compensation

In interpolation type pitch error compensation, the compensation amount at each error compensation point is divided into pulses in the interval between that point and the next point on the travel axis and output, as shown in the figure below.

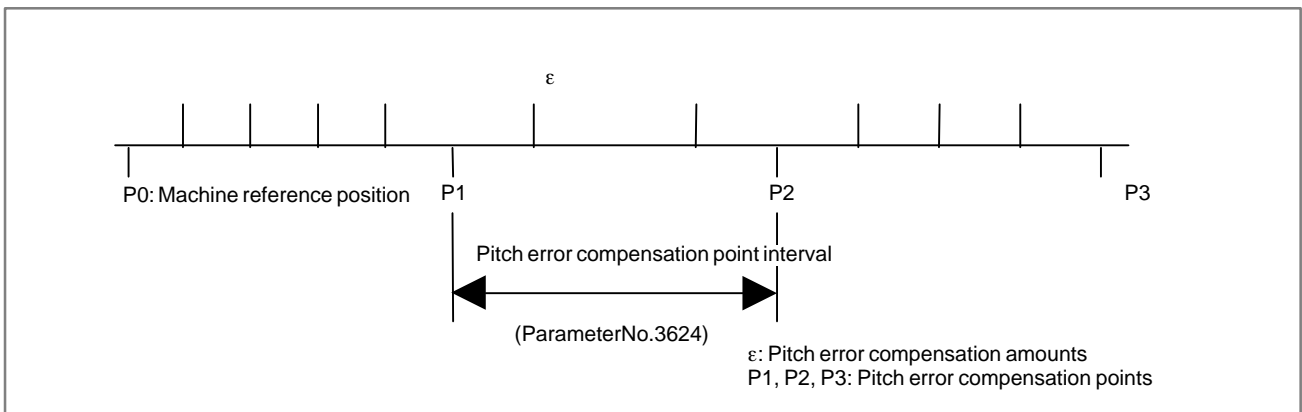

Fig. 1.3.7(b) Interpolation Type Pitch Error Compensation Method

Setting the parameters

When interpolation type pitch error compensation is used, the following parameters are assigned the same values as those in stored pitch error compensation.

- Number of the pitch error compensation point of the reference position on each axis (No.3620)
- Number of the most distant pitch error compensation point on the - side of each axis (No.3621)
- Number of the most distant pitch error compensation point on the + side of each axis (No.3622)
- Pitch error compensation magnification for each axis (No.3623)
- Pitch error compensation point interval on each axis (No.3624)

Minimum pitch error compensation point interval

If the feedrate is high, multiple compensation pulses may be output at the same time. The minimum interval in which multiple compensation pulses are not output at the same time is determined with the following formula. The compensation point interval must be larger than the distance calculated with the following formula.

$$\text{Minimum pitch error compensation point interval} = (F_{\text{max}}/7500) * (P_{\text{max}} + 1)$$

F_{max} : Maximum feedrate

P_{max} : Maximum pitch error compensation amount

Example) If the maximum feedrate is 15000 mm/min and the maximum pitch error compensation amount is equal to seven pulses, the minimum compensation interval is 16mm.

Parameter

	#7	#6	#5	#4	#3	#2	#1	#0
3605							IIP	

[Data type] Bit axis

IIP Specifies whether to use interpolation type pitch error compensation.

0 : Do not use.

1 : Use.

NOTE

When this parameter is set, power must be turned off before operation is continued.

Note

- This function is an option function.
- Stored pitch error compensation option is necessary to use this function.
- This function is available in bi-directional pitch error compensation.

1.3.8 About Differences among Pitch Error Compensation, Straightness Compensation, and Gradient Compensation (for Reference Purposes)

Any of pitch error compensation, straightness compensation, and gradient compensation is applied to each compensation point based on the machine position at parameter-specified compensation intervals into which the machine stroke is divided.

Both gradient compensation and straightness compensation use the same compensation intervals and compensation points as for pitch error compensation. However, they use their own compensation amounts defined for respective compensation functions.

Pitch error compensation

For pitch error compensation, a compensation amount is set up for each compensation point. The compensation amount is output at each compensation point.

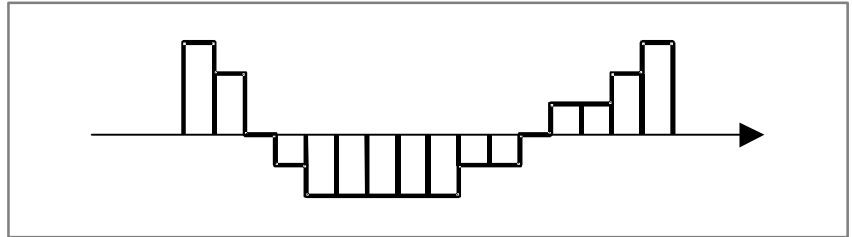

Bidirectional pitch error compensation

For bidirectional pitch error compensation, a compensation amount can be varied according to the axis movement direction.

Interpolation type pitch error compensation

Interpolation type pitch error compensation outputs divided compensation pulses between compensation points, so smoother pitch error compensation can be realized.

Gradient compensation

In gradient compensation, four typical pitch error compensation points (a, b, c, and d) are selected from pitch error compensation points and specified as gradient compensation points, and compensation amounts are set up only for these four points; a compensation amount is not set up for every individual point. For pitch error compensation points between gradient compensation points, the NC calculates and outputs amounts that match gradient compensation. Gradient compensation can be applied if a pitch error has a constant gradient.

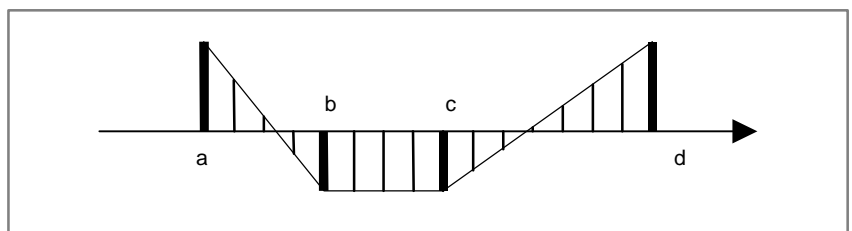

Straightness compensation

In straightness compensation, similarly to gradient compensation, four typical pitch error compensation points (a, b, c, and d) are selected from pitch error compensation points and specified as straightness compensation points, and compensation amounts are set up only for these four points. For pitch error compensation points between straightness compensation points, the NC calculates and outputs amounts that match straightness compensation.

Straightness compensation largely differs from gradient compensation in that the moving axis is not a compensation axis; gradient compensation is applied directly to the moving axis. This relationship is specified by a parameter (for example, to apply compensation to the Y-axis as movement occurs along the X-axis).

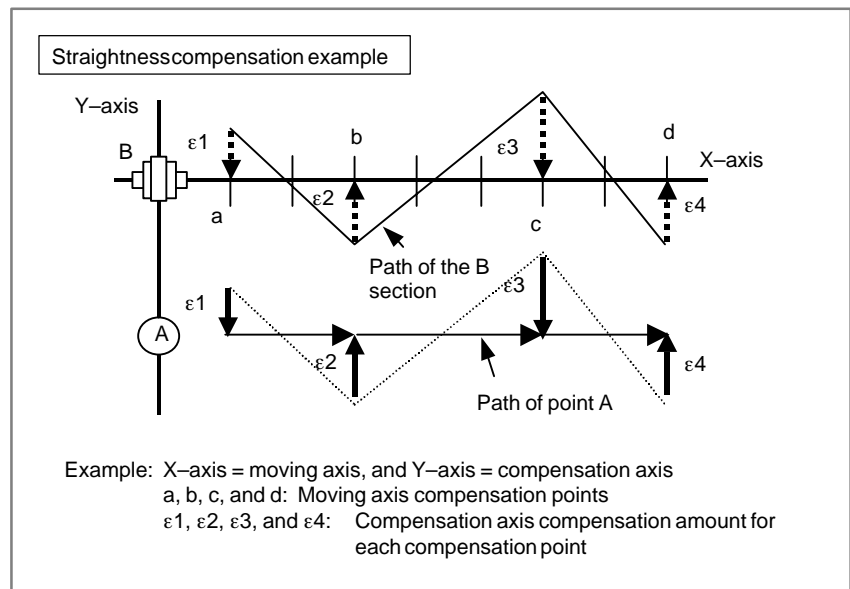

1.3.9 Interpolation type straightness compensation

General

By this function, the following two functions can be used.

- (1) 128 straightness compensation points
- (2) Interpolation type straightness compensation

128 straightness compensation points

- Specification

In straightness compensation, compensation data is set as the compensation amounts at the individual compensation points, in the same way as in stored pitch error compensation. This enables fine compensation.

Up to six combinations of moving axes and compensation axes can be used in the straightness compensation function.

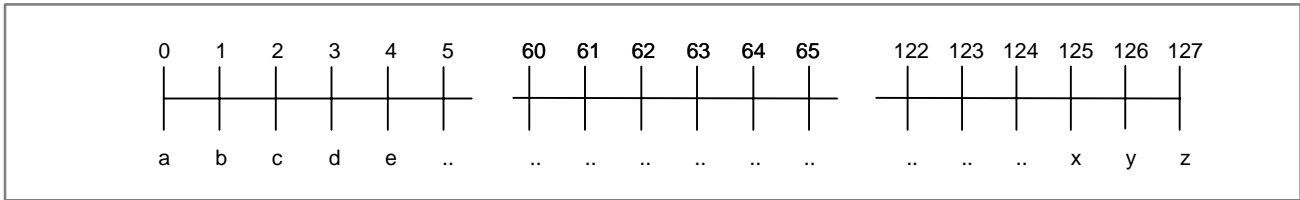

- Up to 128 compensation points can be set per axis.
- The settings (a, b, , , y and z) at the individual compensation points can be from -128 to +127.
- The method of setting data and the compensation timing are the same as those of pitch error compensation.
- To use this function, the pitch error compensation points of a moving axis should be within 128 points.
- The number of straightness compensation points is the same as that of stored pitch error compensation points of a moving axis.

• **Relationship between pitch error compensation points and straightness compensation points on a moving axis**

The relationship between pitch error compensation points and straightness compensation points on a moving axis is as follows.

Stored pitch error compensation points on a moving axis.

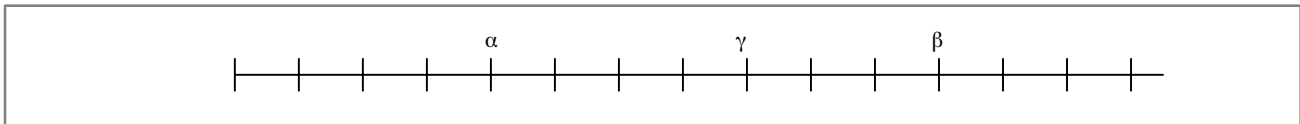

Straightness compensation points on a moving axis

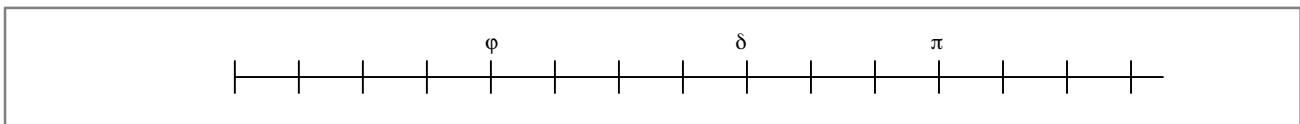

- α: Number of the pitch error compensation point at extremely negative point of the moving axis (parameter No.3621)
- β: Number of the pitch error compensation point at extremely positive point of the moving axis (parameter No.3622)
- γ: Number of the pitch error compensation point for the reference point of the moving axis (parameter No.3620)
- φ: Number of the straightness compensation point at extremely negative point of the moving axis (parameter No.13381 – 13386)
- π: Number of the straightness compensation point at extremely positive point of the moving axis
- δ: Number of the straightness compensation point for the reference point of the moving axis

The following relationships hold :

1. $\delta = \varphi + (\gamma - \alpha)$
2. $\pi = \varphi + (\beta - \alpha)$

and π, δ are automatically calculated from α, β, γ and φ. Therefore, no parameters need to be set for them.

- **Display and setting of straightness compensation data**

The 128-point straightness compensation data is set by the stored pitch error compensation data setting screen. On this setting screen, set 128-point straightness compensation data above compensation point number 6000.

These data can be input and output by the following methods.

- Input by MDI
- Input by G10
- Input and output by input/output device interface
- Input by PMC window (function code 18)

(It is not possible to input and output by the method other than the above methods.)

The 128-point straightness compensation data is input and output in parameter format, in the same way as stored pitch error compensation data. A straightness compensation point number plus 20000 is equal to the corresponding parameter number. (The format is the same as that of pitch error compensation data.)

The input/output of 128-point straightness compensation data is performed at the same time as stored pitch error compensation data.

When 128-point straightness compensation data is used, the point number plus 20000 is equal to the corresponding parameter number as for the stored pitch error compensation.

- **Examples for parameter setting**

As for the method of setting parameters for the moving axes, the compensation axes and the effective magnification, the followings can be set.

(1) A single compensation axis can be set for a single moving axis.

Setting of moving axis		Setting of compensation axis		Effective magnification
Parameter No	Setting value	Parameter No	Setting value	
5711	1	5721	2	Value set in parameter No.13391
5712	3	5722	4	Value set in parameter No.13392
5713	5	5723	6	Value set in parameter No.13393
5714	7	5724	8	Value set in parameter No.13394

When the parameters are set as shown above, by moving the machine along the 1st axis, compensation is applied to the 2nd axis. Similarly, by moving the machine along the 3rd and 5th axis, compensation is applied to the 4th and 6th axis, respectively.

The number of parameter for the magnification that is effective for the individual moving and compensation axis combination is as given in the table above.

(2) Two or more compensation axes can be set for a single moving axis.

Setting of moving axis		Setting of compensation axis		Effective magnification
Parameter No	Setting value	Parameter No	Setting value	
5711	1	5721	2	Value set in parameter No.13391
5712	1	5722	3	Value set in parameter No.13392
5713	1	5723	4	Value set in parameter No.13393
5714	1	5724	5	Value set in parameter No.13394

As described above, two or more compensation axes can be set for a single moving axis.

(3) A compensation axis can be set as a moving axis.

Setting of moving axis		Setting of compensation axis		Effective magnification
Parameter No	Setting value	Parameter No	Setting value	
5711	1	5721	2	Value set in parameter No.13391
5712	2	5722	3	Value set in parameter No.13392
5713	3	5723	4	Value set in parameter No.13393
5714	4	5724	5	Value set in parameter No.13394

As described above, a compensation axis can be set as a moving axis. In this case, the movement amount due to compensation of the moving axis is not subject to compensation.

(4) Two or more moving axes can be set for a single compensation axis.

Setting of moving axis		Setting of compensation axis		Effective magnification
Parameter No	Setting value	Parameter No	Setting value	
5711	1	5721	5	Value set in parameter No.13391
5712	2	5722	5	Value set in parameter No.13392
5713	3	5723	5	Value set in parameter No.13393
5714	4	5724	5	Value set in parameter No.13394

As described above, two or more moving axes can be set for a single compensation axis.

**Interpolation type
straightness
compensation**

● **Specification**

Compensation data, which is set using 128-point straightness compensation data, is divided into parts in each compensation point interval and output.

● **Compensation method**

With the 128-point straightness compensation method, the straightness compensation amount at each compensation point is output to the compensation axis, in the interval between that point and the next point on the moving axis, as shown in the figure below.

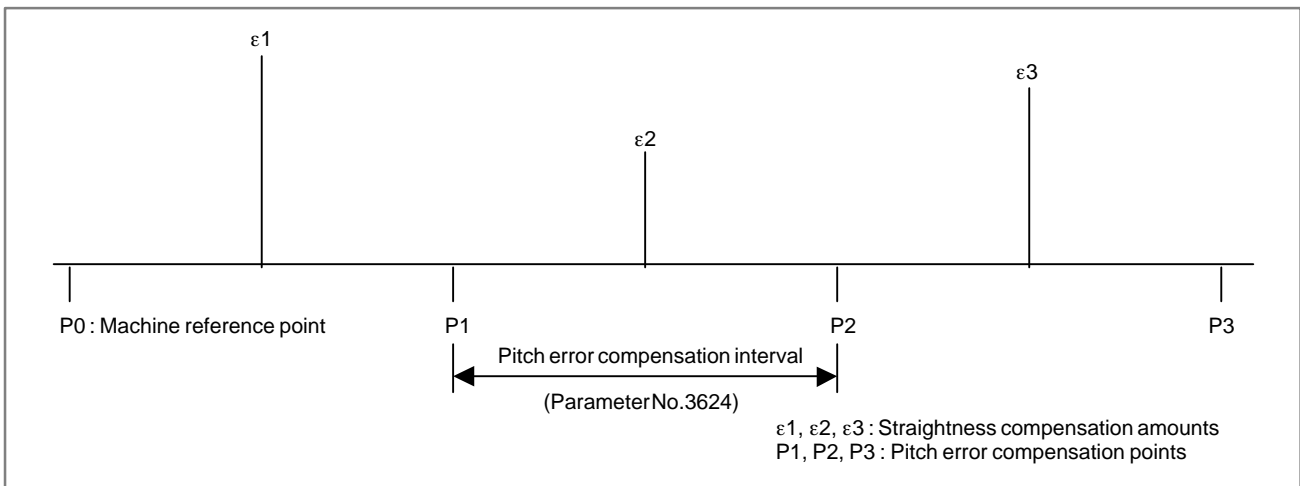

Fig. 1.3.9(a) 128-point straightness compensation method

With the interpolation type straightness compensation method, the straightness compensation amount at each compensation point is divided into pulses in the interval between that point and the next point on the moving axis, and output to the compensation axis.

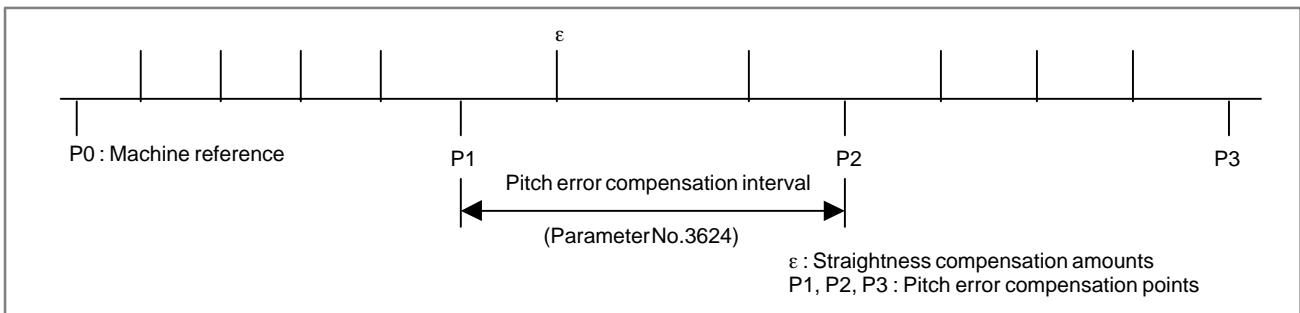

Fig. 1.3.9(b) Interpolation type straightness compensation method

● **Compensation data**

Compensation data is set using 128 straightness compensation points.

Parameter

5711	Axis number of moving axis 1
5712	Axis number of moving axis 2
5713	Axis number of moving axis 3
5714	Axis number of moving axis 4
5715	Axis number of moving axis 5
5716	Axis number of moving axis 6

[Data type] Byte**[Valid data range]** 1 – Number of controlled axes

Set the axis number of moving axes.

5721	Axis number of compensation axis 1 for moving axis 1
5722	Axis number of compensation axis 2 for moving axis 2
5723	Axis number of compensation axis 3 for moving axis 3
5724	Axis number of compensation axis 4 for moving axis 4
5725	Axis number of compensation axis 5 for moving axis 5
5726	Axis number of compensation axis 6 for moving axis 6

[Data type] Byte**[Valid data range]** 1 – Number of controlled axes

Set the axis number of compensation axes.

13381	Number of straightness compensation point at extremely negative point of moving axis 1
13382	Number of straightness compensation point at extremely negative point of moving axis 2
13383	Number of straightness compensation point at extremely negative point of moving axis 3
13384	Number of straightness compensation point at extremely negative point of moving axis 4
13385	Number of straightness compensation point at extremely negative point of moving axis 5
13386	Number of straightness compensation point at extremely negative point of moving axis 6

[Data type] Word

[Valid data range] 6000 to 6767

Set the number of the straightness compensation point at the extremely negative point for each moving axis.

When the value set in this parameter is out of the data range, an alarm is generated and compensation can not be performed.

13391	Magnification of straightness compensation for moving axis 1
13392	Magnification of straightness compensation for moving axis 2
13393	Magnification of straightness compensation for moving axis 3
13394	Magnification of straightness compensation for moving axis 4
13395	Magnification of straightness compensation for moving axis 5
13396	Magnification of straightness compensation for moving axis 6

[Data type] Byte

[Valid data range] 0 to 100

Set the magnification of straightness compensation for each moving axis. When the magnification is set to 1, the unit of compensation data is the same as the detection unit. When the magnification is set to 0, the straightness compensation is not applied.

	#7	#6	#5	#4	#3	#2	#1	#0
3605						IST		

[Data type] Bit

IST Interpolated type straightness compensation is

0 : Not used.

1 : Used.

	#7	#6	#5	#4	#3	#2	#1	#0
5700						SMT	ST6	

[Data type] Bit

SMT Parameter (No.13391–No.13396) for straightness compensation magnification

0 : Are effective only for the first moving axis when two or more moving axes are set using the same axis number.

1 : Are effective for the respective moving axes even when two or more moving axes are set using the same axis number.

ST6 Combination of moving axis and compensation axis is

0 : 3 combinations

1 : 6 combinations

Alarm and message

Number	Message	Description
5046	ILLEGAL PARAMETER (ST.COMP)	The parameter for straightness compensation is not correct. This alarm occurs in the following case: <ul style="list-style-type: none"> • Invalid axis number is assigned to moving or compensation axis. • Parameter No.13881–13886 setting is not correct.
5321	S-COMP. VALUE OVERFLOW	The value of straightness compensation with interpolation type straightness compensation is exceeded maximum value 32767. When this alarm occurs, perform the manual reference position return.

Note

- (1) This function is an option function
- (2) Stored pitch error compensation option is necessary to use this function.
- (3) If the feedrate is high, multiple compensation pulses may be output at the same time depending on the straightness compensation amount.
- (4) The compensation point interval is the same as that of the stored pitch error compensation. (No.3624)
- (5) The compensation magnification can be set separately from that of the stored pitch error compensation.
- (6) The compensation amount corresponding to a compensation point on the moving axis is superimposed on the stored pitch error compensation data for the compensation axis.
- (7) To use this function, the number of pitch error compensation points on the moving axis must not exceed 128 points.
- (8) When setting the straightness compensation parameters, turn the CNC off and on. (When the parameters are set, P/S000 "PLEASE TURN OFF POWER" alarm is generated.)

1.4 SETTINGS RELATED TO SERVO- CONTROLLED AXES

The servo interface of the Series 16 features the following:

Digitally controlled AC servo motor

Motor feedback with serial pulse coders

(1) Absolute pulse coder with a resolution of 1,000,000 pulses/rev

(2) Absolute pulse coder with a resolution of 65,536 pulses/rev

(3) Incremental pulse coder with a resolution of 10,000 pulses/rev

Scale feedback with A/B/Z signal interface

1.4.1 Parameters Related to Servo

General

Explanation of terms frequently used in CNC

Least command increment

The minimum unit of a command to be given from CNC to the machine tool

Detection unit

The minimum unit which can detect the machine tool position

Command multiplier (CMR)

A constant to enable the weight of CNC command pulses to meet the weight of pulses from the detector

Detection multiplier (DMR)

A constant to enable the weight of CNC command pulses to meet the weight of pulses from the detector

CAUTION

The relations among the least command increment, detection unit, CMR, and DMR are as specified below.

Least command increment = CMR × detection unit

$$\text{Detection unit} = \frac{\text{Move amount per revolution of motor}}{\text{DMR} \times \text{number of pulses of detector per revolution}}$$

The flexible feed gear function in the digital servo defines constant DMR using two parameters (Nos. 2084 and 2085) n and m (DMR = n/m).

Parameter

	#7	#6	#5	#4	#3	#2	#1	#0
1800							CVR	

[Data type] Bit

CVR When velocity control ready signal VRDY is set ON before position control ready signal PRDY comes ON

0 : A servo alarm is generated.

1 : A servo alarm is not generated.

	#7	#6	#5	#4	#3	#2	#1	#0
1815			APCx	APZx			OPTx	

NOTE

When this parameter has been set, the power must be turned off before operation is continued.

[Data type] Bit axis

OPTx Position detector

0 : A separate pulse coder is not used.

1 : A separate pulse coder is used.

APZx Machine position and position on absolute position detector when the absolute position detector is used

0 : Not corresponding

1 : Corresponding

WARNING

When an absolute position detector is used, after primary adjustment is performed or after the absolute position detector is replaced, this parameter must be set to 0, power must be turned off and on, then manual reference position return must be performed. This completes the positional correspondence between the machine position and the position on the absolute position detector, and sets this parameter to 1 automatically.

APCx Position detector

0 : Other than absolute position detector

1 : Absolute position detector (absolute pulse coder)

	#7	#6	#5	#4	#3	#2	#1	#0
1816		DM3x	DM2x	DM1x				

NOTE

When this parameter has been set, the power must be turned off before operation is continued.

[Data type] Bit axis

DM1x to DM3x Setting of detection multiplier

Set value			Detection multiplier
DM3x	DM2x	DM1x	
0	0	0	1/2
0	0	1	1
0	1	0	3/2
0	1	1	2
1	0	0	5/2
1	0	1	3
1	1	0	7/2
1	1	1	4

NOTE

When the flexible feed gear is used, do not use these parameters. Set the numerator and denominator of DMR to an appropriate values in parameters 2084 and 2085 respectively.

1820

Command multiplier for each axis (CMR)

NOTE

When this parameter has been set, the power must be turned off before operation is continued.

[Data type] Byte axis

Set a command multiplier indicating the ratio of the least command increment to the detection unit for each axis.

Least command increment = detection unit x command multiplier

Relationship between the increment system and the least command increment

Increment system	Least command increment			Unit
	IS-A	IS-B	IS-C	
Metric machine	0.01	0.001	0.0001	mm
Inch machine	0.001	0.0001	0.00001	inch
Rotation axis	0.01	0.001	0.0001	deg

The value set in the parameter is obtained as follows:

(1) When command multiplier is 1/2 to 1/27

$$\text{Set value} = \frac{1}{(\text{Command multiplier})} + 100$$

Valid data range: 102 to 127

(2) When command multiplier is 1 to 48

Set value = 2 × command multiplier

Valid data range: 2 to 96

NOTE

When command multiplier is 1 to 48, the set value must be determined so that an integer can be set for command multiplier.

1821

Reference counter size for each axis

[Data type] Two-word axis

[Valid data range] 0 to 99999999

Set the size of the reference counter.

NOTE

When this parameter has been set, the power must be turned off before operation is continued.

1825

Servo loop gain for each axis

[Data type] Word axis

[Unit of data] 0.01 s^{-1}

[Valid data range] 1 to 9999

Set the loop gain for position control for each axis.

When the machine performs linear and circular interpolation (cutting), the same value must be set for all axes. When the machine requires positioning only, the values set for the axes may differ from one another. As the loop gain increases, the response by position control is improved. A too large loop gain, however, makes the servo system unstable.

The relationship between the positioning deviation (the number of pulses counted by the error counter) and the feedrate is expressed as follows:

$$\text{Positioning deviation} = \frac{\text{feedrate}}{60 \times (\text{loop gain})}$$

Unit : Positioning deviation: mm, inches, or deg
 Feedrate: mm/min, inches/min, or deg/min
 Loop gain: s^{-1}

1828

Positioning deviation limit for each axis in movement

[Data type] Two-word axis

[Unit of data] Detection unit

[Valid data range] 0 to 99999999

Set the positioning deviation limit in movement for each axis.

If the positioning deviation exceeds the positioning deviation limit during movement, a servo alarm is generated, and operation is stopped immediately (as in emergency stop).

Generally, set the positioning deviation for rapid traverse plus some margin in this parameter.

1829

Positioning deviation limit for each axis in the stopped state

[Data type] Word axis

[Unit of data] Detection unit

[Valid data range] 0 to 32767

Set the positioning deviation limit in the stopped state for each axis.

If, in the stopped state and the positioning deviation exceeds the positioning deviation limit set for stopped state, a servo alarm is generated, and operation is stopped immediately (as in emergency stop).

1832

Feed stop positioning deviation for each axis

[Data type] Two-word axis

[Unit of data] Detection unit

[Valid data range] 0 to 99999999

Set the feed stop positioning deviation for each axis.

If the positioning deviation exceeds the feed stop positioning deviation during movement, pulse distribution and acceleration/deceleration control are stopped temporarily. When the positioning deviation drops to the feed stop positioning deviation or below, pulse distribution and acceleration/deceleration control are resumed.

The feed stop function is used to reduce overshoot in acceleration/deceleration mainly by large servo motors.

Generally, set the mid range value between the positioning deviation limit during movement and the positioning deviation during rapid traverse as the feed stop positioning deviation.

1850

Grid shift for each axis

[Data type] Two-word axis

[Unit of data] Detection unit

[Valid data range] -99999999 to +99999999

A grid shift is set for each axis.

To shift the reference position, the grid can be shifted by the amount set in this parameter. Up to the maximum value counted by the reference counter can be specified as the grid shift.

NOTE

When this parameter has been set, the power must be turned off before operation is continued.

1.4.2 Absolute Position Detection

General

Even when the power to the CNC is turned off, a battery-powered pulse coder stores the current position. No reference position return is required when the power to the CNC is restored.

Signal

Absolute position detector battery voltage low alarm signal PBATL <F172#7>

[Classification] Output signal

[Function] Notifies that the life of the absolute position detector battery, which is used to keep the machine position even when the CNC power is off, is about to expire. Generally, this signal is used to turn on a lamp for calling the operator's attention.

[Operation] The signal becomes 1 when:

- The battery voltage for the absolute position detector becomes lower than or equal to the rating.
The battery need be replaced in the immediate future.

The signal becomes 0 when:

- The battery voltage for the absolute position detector is higher than or equal to the rating.

Absolute position detector battery voltage zero alarm signal PBATZ <F172#6>

[Classification] Output signal

[Function] Notifies that the life of the absolute position detector battery, which is used to keep the machine position even when the CNC power is off, has expired.

[Operation] The signal becomes 1 when:

- The battery voltage for the absolute position detector becomes 0 V.
The battery need be replaced before the CNC power is turned off.

The signal becomes 0 when:

- The battery voltage for the absolute position detector is higher than or equal to 0 V.

Signal address

	#7	#6	#5	#4	#3	#2	#1	#0
F172	PBATL	PBATZ						

Parameter

	#7	#6	#5	#4	#3	#2	#1	#0
1815			APCx					

NOTE

When this parameter has been set, the power must be turned off before operation is continued.

[Data type] Bit axis

APCx Position detector

0: Other than absolute position detector

1: Absolute position detector (absolute pulse coder)

1.4.3 FSSB Setting

Overview

Connecting the CNC control section to servo amplifiers via a high-speed serial bus (FANUC Serial Servo Bus, or FSSB), which uses only one fiber optics cable, can significantly reduce the amount of cabling in machine tool electrical sections.

In a system using the FSSB, it is necessary to set up the following parameters to specify its axes. (The other parameters should be specified as usual.)

- Parameter No. 1023
- Parameter No. 1905
- Parameter Nos. 1910 to 1919
- Parameter Nos. 1936 and 1937

These parameters can be specified using the following methods:

1. Manual setting 1

Parameters are defaulted according to the setting of parameter No. 1023. There is no need to specify parameter Nos. 1905, 1910 to 1919, 1936 and 1937. No automatic setting is used. Note that some functions are unusable.

2. Automatic setting

Axis settings are calculated automatically according to the interrelationships between axes and amplifiers entered on the FSSB setting screen. Parameter Nos. 1023, 1905, 1910 to 1919, 1936, and 1937 are specified automatically according to the results of the calculation.

3. Manual setting 2

Parameter Nos. 1023, 1905, 1910 to 1919, 1936, and 1937 are specified according to manually entered values. The user must be totally familiar with the meaning of each parameter before entering any values.

Slave

In an FSSB-based system, a fiber optics cable is used to connect the CNC to servo amplifiers and separate detector interface units. These amplifiers and separate detector interface units are called slaves. The two-axis amplifier consists of two slaves, and the three-axis amplifier consists of three slaves. The slaves are numbered 1, 2, ..., 10 (slave number) sequentially, with that nearest to the CNC starting at number 1.

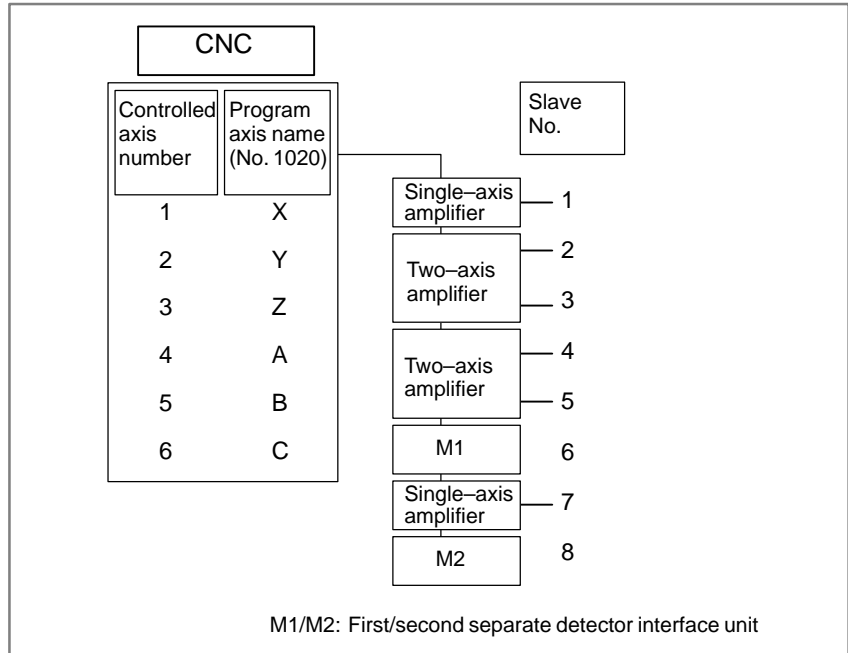

Manual setting 1

The manual setting 1 is valid when the following parameter have the following values:

- Bit 0 of parameter No. 1902 = 1
- Bit 1 of parameter No. 1902 = 0
- Parameter Nos. 1910 to 1919 = all 0s

By manual setting 1, the value set for parameter No. 1023 when the power is switched on is regarded as a slave number. Specifically, an axis for which parameter No. 1023 is set to 1 is connected to the amplifier nearest to the CNC, while an axis for which parameter No. 1023 is set to 2 is the second one from the CNC.

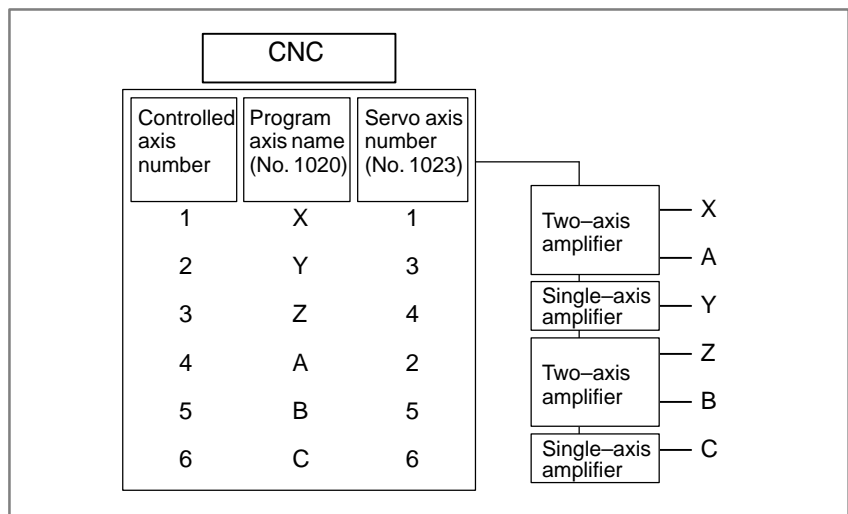

By manual setting 1, some of the following functions and values cannot be used, as described below. They should be used with automatic setting or manual setting 2.

- No separate detector interface unit can be used; hence, no separate position detectors can be used.
- No number can be skipped in parameter No. 1023; for example, number 3 cannot be used for any axis unless number 2 is used.
- The following servo functions cannot be used:
 - Learning control
 - High-speed current loop
 - High-speed interface axis
 - Simple electronic gearbox (EGB)

Automatic setting

Automatic setting can be used on the FSSB setting screen, if the following parameter is set as follows:

Bit 0 of parameter No. 1902 = 0

On the FSSB setting screen, automatic setting should be enabled by means of the following procedure:

1. On the amplifier setting screen, specify the axis number of a controlled axis to be connected to each amplifier.
2. Press the [SETTING] soft key. (If a warning message is displayed, restart from step 1.)
3. On the axis setting screen, specify information about each axis, such as a separate detector interface unit connector No.
4. Press the [SETTING] soft key. (If a warning message is displayed, repeat the procedure, starting from step 3.)

In this way, parameter Nos. 1023, 1905, 1910 to 1919, 1936, and 1937 are set according to the results of automatic calculation. In addition, bit 1 of parameter No. 1902 is set to 1 to indicate that each parameter has been set up. Switching the power off then back on again causes axis setting to be performed according to these parameter settings.

For details of the FSSB setting screen, see the FSSB data display and setting procedure, described below.

NOTE

To use the simple electronic gearbox (EGB), perform EGB axis setting (parameter No. 7771) before automatic setting on the FSSB setting screen. Otherwise, automatic setting cannot be performed correctly.

Manual setting 2

If the following parameter is set, manual setting 2 can be used for each parameter axis setting.

Bit 0 of parameter No. 1902 = 1

To perform manual setting 2, set parameter Nos. 1023, 1905, 1910 to 1919, 1936, and 1937. Refer to the Parameter Manual for the definition of each parameter.

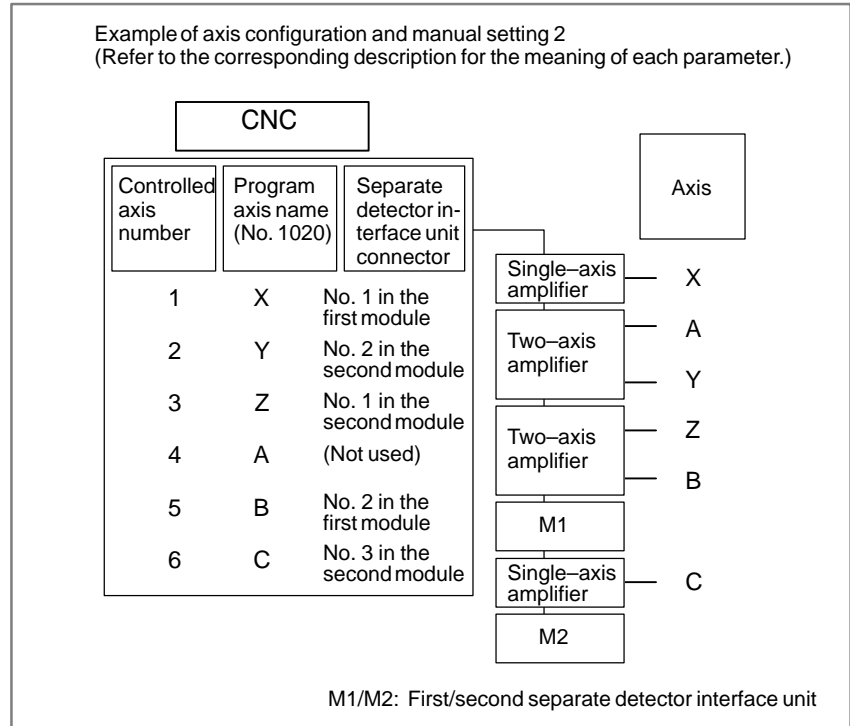

No.	1902#0 FMD
	1



No.	1910	1911	1912	1913	1914	1915	1916	1917	1918	1919
	0	1	2	3	4	16	5	48	40	40

No.	1023	1905#0 FSL	1905#6 PM1	1905#7 PM2	1936	1937
X	1	0	1	0	0	0
Y	3	0	0	1	0	1
Z	4	1	0	1	0	0
A	2	1	0	0	0	0
B	5	0	1	0	1	0
C	6	1	0	1	0	2

FSSB display and setting procedure

• Display

The FSSB setting screen displays FSSB-based amplifier and axis information. This information can also be specified by the operator.

1. Press the  function key.
2. To display [FSSB], press the  next menu page key several times.
3. Pressing the [FSSB] soft key causes the [AMPLIFIER SETTING] screen (or the previously selected FSSB setting screen) to appear, with the following soft keys displayed.

[AMP] [AXIS] [MAINTE] [] [(OPRT)]

The FSSB setting screens include: [AMPLIFIER SETTING], [AXIS SETTING], and [AMPLIFIER MAINTENANCE]

Pressing the [AMP] soft key causes the [AMPLIFIER SETTING] screen to appear.

Pressing the [AXIS] soft key causes the [AXIS SETTING] screen to appear.

Pressing the [MAINTE] soft key causes the [AMPLIFIER MAINTENANCE] screen to appear.

(1) Amplifier setting screen

The amplifier setting screen consists of two sections: the first section displays information about the amplifiers, while the second section displays information about the separate detector interface units.

AMPLIFIER SETTING				O1000 N00001		
NO.	AMP	SERIES	UNIT	CUR.	AXIS	NAME
1	A1-L	α	SVM-HV	40AL	1	X
2	A1-M	α	SVM	12A	2	Y
3	A2-L	β	SVM	40A	3	Z
4	A3-L	α	SVM	20A	4	A
5	A3-M	α	SVM	40A	5	B
7	A4-L	α	SVU	240A	6	C
NO. EXTRA TYPE PCB ID						
6	M1	A	0000 DETECTOR (8AXES)			
8	M2	B	12AB			
>_						
MDI **** * * * *				13:11:56		
[AMP] [AXIS] [MAINTE] [] [(OPRT)]						

The amplifier setting screen consists of the following items:

- NO. . . slave number
The numbers of up to ten slaves (up to eight amplifiers and up to two separate detector interface units) connected via the FSSB are displayed sequentially, with the one nearest the CNC being number 1.

- **AMP** amplifier type
The amplifier type display consists of the letter A, which stands for “amplifier”, a number that indicates the placing of the amplifier, as counted from that nearest to the CNC, and a letter such as L (first axis) or M (second axis) indicating the placing of the axis in the amplifier.
- **AXIS** controlled axis number
The axis number of each controlled axis specified in parameters (Nos. 1920 to 1929) is displayed. If a number specified in these parameters falls outside the range of 1 and the maximum number of controlled axes, 0 is displayed.
- **NAME . . .** controlled axis name
The axis name assigned to a parameter (No. 1020) corresponding to a particular controlled axis number is displayed. If the controlled axis number is 0, – is displayed.
- The following items are displayed as amplifier information:
 - **UNIT** servo amplifier unit type
 - **SERIES . . .** servo amplifier series
 - **CUR.** maximum rating current
- The following items are displayed as separate detector interface unit information:
 - **EXTRA**
This consists of the letter M, which stands for “separate detector interface unit”, and a number indicating the placing of the separate detector interface unit, as counted from that nearest to the CNC.
 - **TYPE**
This is a letter indicating the type of the separate detector interface unit.
 - **PCB ID**
This consists of four digits indicating the separate detector interface unit ID (hexadecimal). The separate detector interface unit ID is followed by DETECTOR (8AXES) when 8–axes separate detector interface unit or DETECTOR (4AXES) when 4–axes separate detector interface unit.

(2) Axis setting screen

The axis setting screen displays the information shown below:

AXIS SETTING						O1000	N00001
AXIS	NAME	AMP	M1	M2	1-DSP	CS	TNDM
1	X	A1-L	0	0	0	0	1
2	Y	A1-M	1	0	1	0	0
3	Z	A2-L	0	0	0	1	0
4	A	A3-L	0	0	0	0	2
5	B	A3-M	0	0	0	0	0
6	C	A4-L	0	0	0	0	0



>
 MDI **** * * * * 13:11:56
 [AMP] [AXIS] [MAINT] [(OPRT)]

The axis setting screen displays the following items:

- **AXIS** controlled axis number
This item is the placing of the NC controlled axis.
- **NAME** . . . controlled axis name
- **AMP** type of the amplifier connected to each axis
- **M1** connector number for separate detector interface unit 1
This item is the number of the connector for separate detector interface unit 1, specified in parameter No. 1931.
- **M2** connector number for separate detector interface unit 2
This item is the number of the connector for separate detector interface unit 2, specified in parameter No. 1932.
- **1-DSP**
This item is the value specified in bit 0 (parameter 1DSP) of parameter No. 1904. It is 1 for an axis (such as a learning control axis, high-speed current loop axis, or high-speed interface axis) that exclusively uses a DSP, which is usually shared by two axes.
- **CS** Cs contour controlled axis
This item is the value specified in parameter No. 1933. It is 1 for the Cs contour controlled axis.
- **TNDM** (M series only)
This item is the number specified in parameter No. 1934. Consecutive odd and even numbers are displayed for the master and slave axes for tandem control.

(3) Amplifier maintenance screen

The amplifier maintenance screen displays maintenance information for servo amplifiers. This screen consists of the following two pages,

either of which can be selected by pressing the  or  key.

AMPLIFIER MAINTENANCE						O1000 N00001
AXIS	NAME	AMP	SERIES	UNIT	AXES	CUR.
1	X	A1-L	α	SVM-HV	2	40AL
2	Y	A1-M	α	SVM	2	12A
3	Z	A2-L	β	SVM	1	40A
4	A	A3-L	α	SVM	2	20A
5	B	A3-M	α	SVM	2	40A
6	C	A4-L	α	SVU	1	240A

>_
MDI **** * 13:11:56
[AMP][AXIS][MAINTE][]

AMPLIFIER MAINTENANCE					O1000 N00001
AXIS	NAME	EDITION	TEST	MEINTE-NO.	
1	X	01A	010123	01	
2	Y	01A	010123	01	
3	Z	01A	010123	01	
4	A	02B	010123	01	
5	B	02B	010123	01	
6	C	02B	010123	01	

>_
MDI **** * 13:11:56
[AMP][AXIS][MAINTE][]

The amplifier maintenance screen displays the following items:

- AXIS controlled axis number
- NAME controlled axis name
- AMP type of amplifier connected to each axis
- SERIES servo amplifier series of an amplifier connected to each axis
- UNIT unit type of a servo amplifier connected to each axis
- AXES maximum number of axes controlled by an amplifier connected to each axis
- CUR. maximum rating current for amplifiers connected to each axis
- EDITION unit version number of an amplifier connected to each axis

- TEST date of test performed on an amplifier connected to each axis
Example) 010123 = January 23, 2001
- MEINTE-No. . . engineering change number for an amplifier connected to each axis

● **Setting**

On an FSSB setting screen (other than the amplifier maintenance screen), pressing the [(OPRT)] soft key displays the following soft keys:



To enter data, place the machine in MDI mode or the emergency stop state, position the cursor to the point where a desired item is to be input, then enter the desired data and press the [INPUT] soft key (or the key on the MDI panel).

When the [SETING] key is pressed after data has been entered, a warning message is displayed if the entered data contains an error. When the data is valid, the corresponding parameter is set up.

To restore the previous value of a parameter if, for example, an entered value is incorrect, press the [CANCEL] soft key.

When the power is switched on, values are read from the parameters and displayed on the screen.

CAUTION

- 1 For the parameters to be specified on the FSSB setting screen, do not attempt to enter values on the parameter screen using the MDI or a G10 command. Use only the FSSB screen to enter values for these parameters.
- 2 If pressing the [SETING] key results in a warning message being displayed, retry data entry, or press the [CANCEL] key to clear the warning message. Note that pressing the reset key does not clear the warning message.

(1) Amplifier setting screen

AMPLIFIER SETING					O1000 N00001	
NO.	AMP	SERIES	UNIT	CUR.	AXIS	NAME
1	A1-L	α	SVM-HV	40AL	1	X
2	A1-M	α	SVM	12A	2	Y
3	A2-L	β	SVM	40A	3	Z
4	A3-L	α	SVM	20A	4	A
5	A3-M	α	SVM	40A	5	B
7	A4-L	α	SVU	240A	6	C
NO.	EXTRA	TYPE	PCB ID			
6	M1	A	0000 DETECTOR (8AXES)			
8	M2	B	12AB			
>_						
MDI **** * * * *				13:11:56		
[AMP]	[AXIS]	[MAINTE]	[(OPRT)]			

The amplifier setting screen displays the following items:

- **AXIS . . . controlled axis number**
 For this item, enter a value of between 1 and the maximum number of controlled axes. If a number that falls outside this range is entered, the warning message **FORMAT ERROR** appears. If the entered controlled axis number is duplicate or 0, the warning message **DATA IS OUT OF RANGE** appears when the [SETTING] soft key is pressed to assert the entered value. In this case, no value can be entered for the parameter.

(2) Axis setting screen

AXIS SETTING							O1000 N00001	
AXIS	NAME	AMP	M1	M2	1-DSP	CS	TNDM	
1	X	A1-L	0	0	0	0	1	
2	Y	A1-M	1	0	1	0	0	
3	Z	A2-L	0	0	0	1	0	
4	A	A3-L	0	0	0	0	2	
5	B	A3-M	0	0	0	0	0	
6	C	A4-L	0	0	0	0	0	

>_

MDI **** * * * * 13:11:56

[SETING] [] [CANCEL] [] [INPUT]

On the axis setting screen, the following items can be specified:

- **M1 . . . connector number for separate detector interface unit 1**
 For an axis that uses separate detector interface unit 1, enter a connector number using a number in the range of between 1 and the maximum number of axes for separate detector interface unit 1. When separate detector interface unit 1 need not be used, enter 0. If a number that falls outside the valid range is entered, the message **FORMAT ERROR** is displayed.
- **M2 . . . connector number for separate detector interface unit 2**
 For an axis that uses separate detector interface unit 2, enter a connector number using a number in the range of between 1 and the maximum number of axes for separate detector interface unit 2. When separate detector interface unit 2 need not be used, enter 0. If a number that falls outside the valid range is entered, the message **FORMAT ERROR** is displayed.
- **1-DSP**
 Enter 1 for the following axes, each of which exclusively uses a DSP, which is usually shared by two axes. If a number other than 0 or 1 is entered, the message **FORMAT ERROR** is displayed.
 - Learning control axis
 - High-speed current loop axis
 - High-speed interface axis
- **CS . . Cs contour controlled axis**
 Enter 1 for the Cs contour controlled axis. If a number other than 0 or 1 is entered, the message **FORMAT ERROR** is displayed.

- **TNDM**
Enter odd and even numbers for the master and slave axes for tandem control. These numbers must be consecutive and in the range of between 1 and 8. If a number that falls outside the valid range is entered, the message **FORMAT ERROR** is displayed.

When the [SETTING] soft key is pressed on the axis setting screen after data entry, the message **DATA IS OUT OF RANGE** is displayed if any of the following conditions is satisfied.

- Both M1 and M2 are nonzero for an axis.
- Any two of the 1-DSP, CS, and TNDM are nonzero for an axis.
- A duplicate value is specified for M1.
- A duplicate value is specified for M2.
- A duplicate value is specified for CS.
- A duplicate value is specified for TNDM.
- An invalid master/slave axis pair is specified for TNDM.

Parameter

	#7	#6	#5	#4	#3	#2	#1	#0
1902							ASE	FMD

[Data type] Bit

- FMD** Specifies the FSSB setting mode.
0 : Automatic setting mode.
(If the interrelationships between axes and amplifiers are specified on the FSSB setting screen, parameter Nos. 1023, 1905, 1910 to 1919, 1936, and 1937 are set automatically.)
1 : Manual setting 2 mode.
(Parameter Nos. 1023, 1905, 1910 to 1919, 1936, and 1937 must be set manually.)
- ASE** Indicates whether automatic setting is complete, if bit 0 of parameter No. 1902 is 0 (automatic setting mode).
0 : Incomplete.
1 : Complete.
(This bit automatically becomes 1 upon the completion of automatic setting.)

	#7	#6	#5	#4	#3	#2	#1	#0
1904								DSP

[Data type] Bit axis

- DSP** 0 : Two axes share a DSP. (Ordinary axis)
1 : One axis occupies a DSP. (Learning control axis, and so on)
Usually, the user should not attempt to manipulate this bit, because it is set using the FSSB setting screen. It need not be used in FSSB manual setting 2 mode.

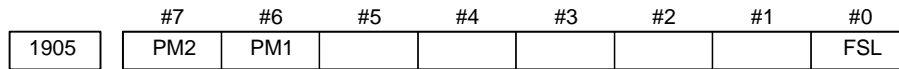

[Data type] Bit axis

FSL Specifies whether to use a fast or slow interface between a servo amplifier and the servo software.

0 : Fast type

1 : Slow type

There are two types of servo data transfer interfaces: fast and slow types. They are selected as described below.

- Both types are usable for single-axis amplifiers.
- For two-axis amplifiers, do not use fast type interfaces for both axes simultaneously. Slow types can be used simultaneously for both axes.
- For three-axis amplifiers, the same rules as those for two-axis amplifiers apply for the first and second axes, while the same rules as those for single-axis amplifiers apply for the third axis.
- For those axes for which an odd number is set for parameter No. 1023, the fast type must be used, except for the EGB workpiece, learning control, high-speed current loop, and high-speed interface axes, for which the slow type can also be used.
- For those axes for which an even number is set for parameter No. 1023, only the slow type is usable; this bit must be set to 1.

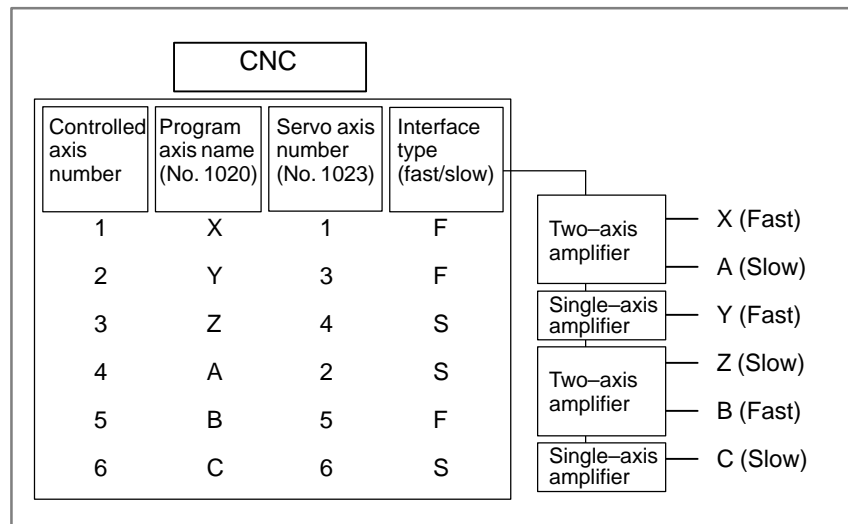

PM1 Specifies whether the first separate detector unit is to be used.

0 : Not used.

1 : Used.

PM2 Specifies whether the second separate detector unit is to be used.

0 : Not used.

1 : Used.

If automatic setting is set as the FSSB setting mode (bit 0 of parameter No. 1902 = 0), this parameter is set automatically when data is entered using the FSSB setting screen. For manual setting 2 (bit 0 of parameter No. 1902 = 1), the user must set this parameter. When using a separate detector interface unit, a connection number must be specified separately (parameter Nos. 1936 and 1937).

1910	Address conversion table value for slave 1 (ATR)
1911	Address conversion table value for slave 2 (ATR)
1912	Address conversion table value for slave 3 (ATR)
1913	Address conversion table value for slave 4 (ATR)
1914	Address conversion table value for slave 5 (ATR)
1915	Address conversion table value for slave 6 (ATR)
1916	Address conversion table value for slave 7 (ATR)
1917	Address conversion table value for slave 8 (ATR)
1918	Address conversion table value for slave 9 (ATR)
1919	Address conversion table value for slave 10 (ATR)

[Data type] Byte

[Valid data range] 0 to 7, 16, 40, and 48

An address conversion table value must be specified for each of slaves 1 to 10. The term “slave” refers to any of the servo amplifiers and separate detector interface units connected to the CNC. Each slave is assigned a number of between 1 and 10 sequentially, with the one nearest to the CNC assigned number 1. A two-axis amplifier is regarded as being two slaves, while a three-axis amplifier is regarded as being three slaves. Each of these parameters is set depending on whether the slave is an amplifier or separate detector interface unit, as follows:

- When the slave is an amplifier:
The parameter is set to the “value in parameter No. 1023 for an axis to which the amplifier is assigned,” minus 1.
- When the slave is a separate detector interface unit:
The parameter is set to 16 for the first separate detector interface unit (that nearest to the CNC) or to 48 for the second separate detector interface unit (that farthest from the CNC).
- When there is no slave:
The parameter is set to 40 except when the simple electronic gearbox (EGB) is used, in which case the following should be observed.
- When the simple electronic gearbox (EGB) is used:
The EGB axis (that axis specified with parameter No. 7771) requires no amplifier. It should be regarded as being connected to a dummy amplifier; that is, the address conversion table value for one of the non-existing slaves should be set to the “value set in parameter No. 1023 for the EGB axis,” minus 1, rather than 40.

If automatic setting is set as the FSSB setting mode (bit 0 of parameter No. 1902 = 0), this parameter is set automatically when data is entered on the FSSB setting screen. For manual setting 2 (bit 0 of parameter No. 1902 = 1), the parameter must be set manually.

○ Example of axis configuration and parameter setting

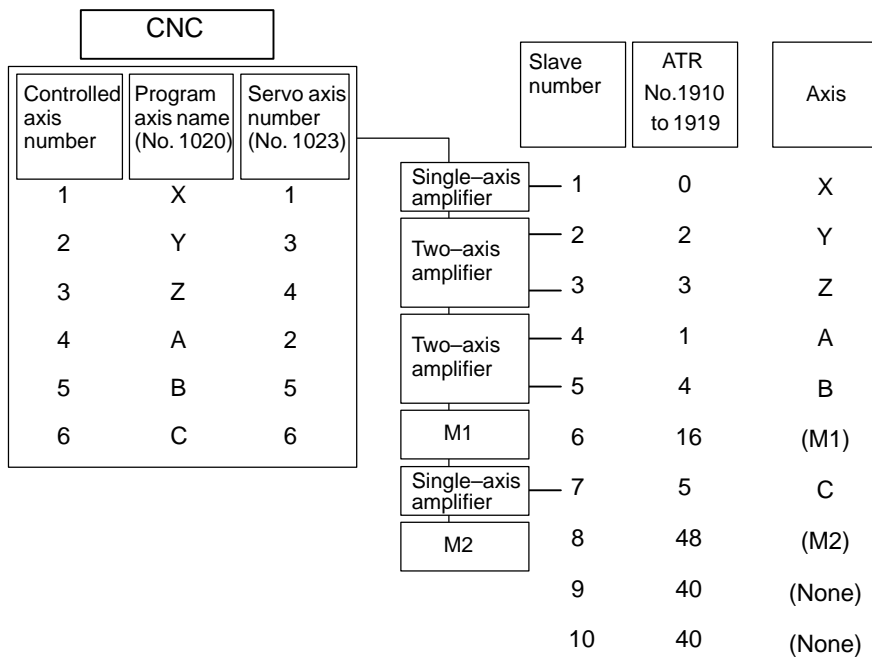
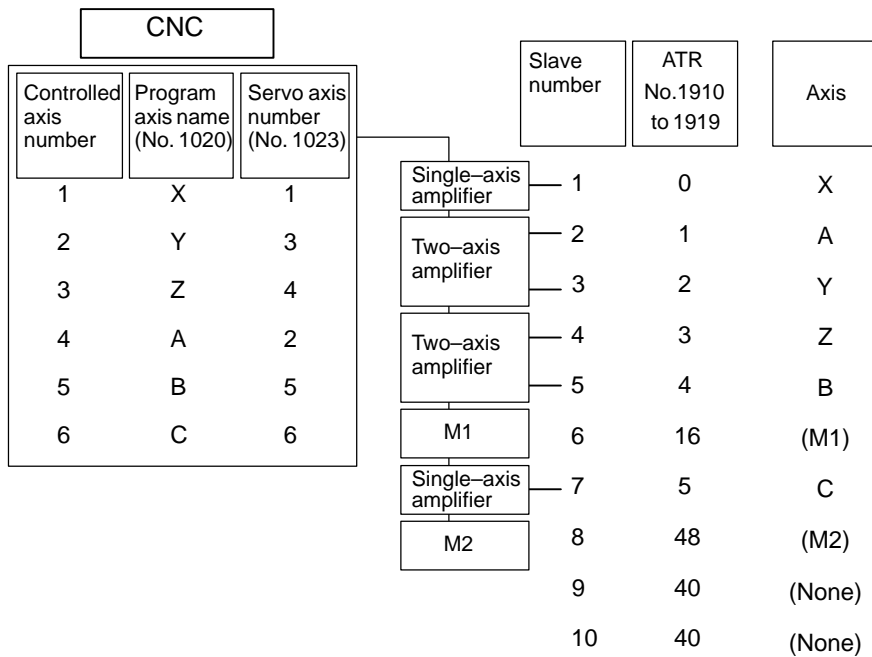

M1/M2: First/second separate detector interface unit

- Example of axis configuration and parameter setting when the simple electronic gearbox (EGB) function is used
(EGB workpiece axis = A-axis; EGB axis = B-axis (parameter No. 7771 = 5))

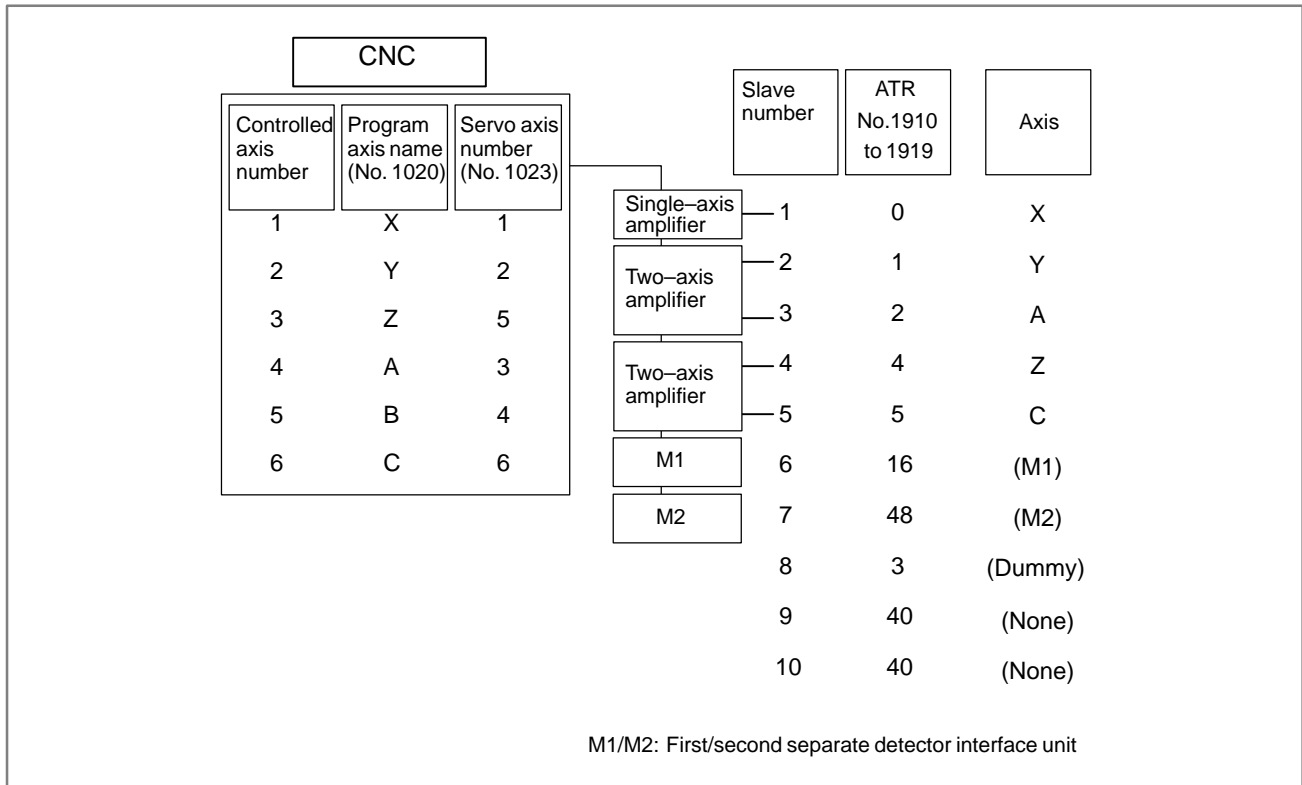

1920	Controlled axis number for slave 1 (FSSB setting screen only)
1921	Controlled axis number for slave 2 (FSSB setting screen only)
1922	Controlled axis number for slave 3 (FSSB setting screen only)
1923	Controlled axis number for slave 4 (FSSB setting screen only)
1924	Controlled axis number for slave 5 (FSSB setting screen only)
1925	Controlled axis number for slave 6 (FSSB setting screen only)
1926	Controlled axis number for slave 7 (FSSB setting screen only)
1927	Controlled axis number for slave 8 (FSSB setting screen only)
1928	Controlled axis number for slave 9 (FSSB setting screen only)
1929	Controlled axis number for slave 10 (FSSB setting screen only)

[Data type] Byte

[Valid data range] 0 to 8

Each of these parameters is set using a controlled axis number for a slave numbered 1 to 10. This parameter is set automatically when data is entered using the FSSB setting screen; do not specify it manually. For manual setting 2, the parameter need not be set.

1931	Connector number for first separate detector interface unit (FSSB setting screen only)
1932	Connector number for second separate detector interface unit (FSSB setting screen only)

[Data type] Byte axis

[Valid data range] 0 to the number of connectors in each separate detector interface unit

To use a separate detector interface unit, the user must specify a connector number for the separate detector interface unit on each axis. This parameter is set automatically when data is entered using the FSSB setting screen; do not specify it manually. For manual setting 2, the parameter need not be set.

1933	Cs contour controlled axis (FSSB setting screen only)
------	---

[Data type] Byte axis

[Valid data range] 0 and 1

To use Cs contour control, this parameter must be set to 1 for the corresponding axis. This parameter is set automatically when data is entered using the FSSB setting screen; do not specify it manually. For manual setting 2, the parameter need not be set.

1934	Master/slave number for tandem-controlled axes (FSSB setting screen only)
------	---

[Data type] Byte axis

[Valid data range] 0 to 8

To use tandem control, this parameter must be set to an odd number (for the master axis) or to an even number (slave axis). This parameter is set automatically when data is entered using the FSSB setting screen; do not set it manually. For manual setting 2, the parameter need not be set.

1936	Connector number for first separate detector interface unit
1937	Connector number for second separate detector interface unit

[Data type] Byte axis

[Valid data range] 0 to 7

To use a separate detector interface unit, this parameter must be set to “connection number for the separate detector interface unit,” minus 1; that is, 0 for connector number 1, 1 for connector number 2, and so on. It is also necessary to set up bits 6 and 7 of parameter No. 1905. For an axis that does not use a separate detector interface unit, 0 is specified for the parameter. Any connector can be used for any axis, however the connectors in a single separate detector interface unit should be used in ascending order of connector number. For instance, connector 4 of a separate detector interface unit cannot be used without using connector 3 of the same separate detector interface unit.

Example)

Controlled axis	Connector number for first separate detector interface unit	Connector number for second separate detector interface unit	No.1936	No.1937	No.1905 (#7, #6)
X	1	Not used	0	0	0,1
Y	Not used	2	0	1	1,0
Z	Not used	1	0	0	1,0
A	Not used	Not used	0	0	0,0
B	2	Not used	1	0	0,1
C	Not used	3	0	2	1,0

If the FSSB setting mode is automatic setting (bit 0 of parameter No. 1902 = 0), this parameter is set automatically when data is entered using the FSSB setting screen. For manual setting 2 (bit 0 of parameter No. 1902 = 1), the user must set this parameter.

Alarm and message

• Servo alarms

Number	Message	Description
456	ILLEGAL CURRENT LOOP	The current control cycle settings (parameter No. 2004, bit 0 of parameter No. 2003, and bit 0 of parameter No. 2013) are incorrect. Possible problems are as follows. <ul style="list-style-type: none"> For the two axes whose servo axis numbers (settings of parameter No. 1023) are an odd number followed by an even number (a pair of axes 1 and 2 or axes 5 and 6, for example), a different current control cycle is set for each of the axes. The requirements for slaves needed for the set current control cycle, including the number, type, and connection method of them, are not satisfied.
457	ILLEGAL HI HRV (250US)	Use of high-speed HRV is specified although the current control cycle is 200 μ s.
458	CURRENT LOOP ERROR	The current control cycle setting does not match the actual current control cycle.
459	HI HRV SETTING ERROR	For the two axes whose servo axis numbers (settings of parameter No. 1023) are an odd number followed by an even number (a pair of axes 1 and 2 or axes 5 and 6, for example), the SVM for one of the axes supports high-speed HRV control but the SVM for the other does not. Refer to the SVM specification.

Number	Message	Description
460	n AXIS : FSSB DISCONNECT	FSSB communication was interrupted. The most likely causes are: 1. The FSSB communication cable is disconnected or has a broken conductor. 2. The amplifier power supply was turned off. 3. A low-voltage alarm condition occurred in the amplifier.
461	n AXIS : ILLEGAL AMP INTERFACE	The fast type interface was assigned to both axes of a two-axis amplifier.
462	n AXIS : SEND CNC DATA FAILED	The slave could not receive data correctly because of an FSSB communication error.
463	n AXIS : SEND SLAVE DATA FAILED	The servo section failed to receive data correctly because of an FSSB communication error.
465	n AXIS : READ ID DATA FAILED	An attempt to read the initial ID information for the amplifier failed when the power was switched on.
466	n AXIS : MOTOR/AMP COMBINATION	The maximum current rating for the amplifier does not match that for the motor.
467	n AXIS : ILLEGAL SETTING OF AXIS	The servo function for the following has not been enabled when an axis occupying a single DSP is specified on the axis setting screen. 1. Learning control (bit 5 of parameter No. 2008 = 1) 2. High-speed current loop (bit 0 of parameter No. 2004 = 1) 3. High-speed interface axis (bit 4 of parameter No. 2005 = 1)
468	HI HRV SETTING ERROR(AMP)	Use of high-speed HRV is specified for a controlled axis of an amplifier which does not support high-speed HRV.

- P/S alarms

Number	Message	Description
5134	FSSB : OPEN READY TIME OUT	The FSSB did not become ready to open during initialization.
5135	FSSB : ERROR MODE	The FSSB entered an error mode.
5136	FSSB : NUMBER OF AMPS IS SMALL	The number of amplifiers recognized by the FSSB is insufficient, compared with the number of controlled axes.
5137	FSSB : CONFIGURATION ERROR	The FSSB detected a configuration error. The address conversion table value (ATR) setting (parameter Nos. 1910 to 1919 and 1970 to 1979) for a slave axis does not match the type of a slave axis actually connected to the FSSB.

Number	Message	Description
5138	FSSB : AXIS SETTING NOT COMPLETE	Axis setting has not been performed in automatic setting mode. Perform axis setting using the FSSB setting screen.
5139	FSSB : ERROR	The initialization of the servo was not completed normally. Probable cases are a defect of optical cable or a mistake of the connection between the amplifier and other modules.
5197	FSSB : OPEN TIME OUT	The FSSB did not open when the CNC had allowed the FSSB to open.
5198	FSSB : ID DATA NOT READ	The initial ID information for the amplifier cannot be read because of a failure in the temporary assignment.
5311	FSSB: ILLEGAL CONNECTION	A connection related to FSSB is illegal. This alarm is issued when either of the following is found: <ol style="list-style-type: none"> 1 Two axes having adjacent servo axis numbers (parameter No. 1023), odd number and even number, are assigned to amplifiers to which different FSSB systems are connected. 2 The system does not satisfy the requirements for performing HRV control, and use of two pulse modules connected to different FSSB systems having different FSSB current control cycles is specified.

1.4.4 Tentative Absolute Coordinate Setting (M Series)

General

In a full-closed system with a built-in absolute position detector (serial pulse coder) and incremental linear scale, a coordinate system is set up, using absolute position data received from the built-in absolute position detector when the power is switched on. After this, position control is carried out using the linear scale incremental data. Because the machine position obtained immediately after the power is switched on is tentative, obtaining the accurate machine position requires making a manual reference position return.

Even before a reference position return is made, using this function enables a stroke limit, although the machine position obtained when the power is switched on is approximate.

Note that this function is not intended to use an incremental linear scale as an absolute position detector.

This function can be used only for a linear scale with absolute addressing reference marks.

This function is an option.

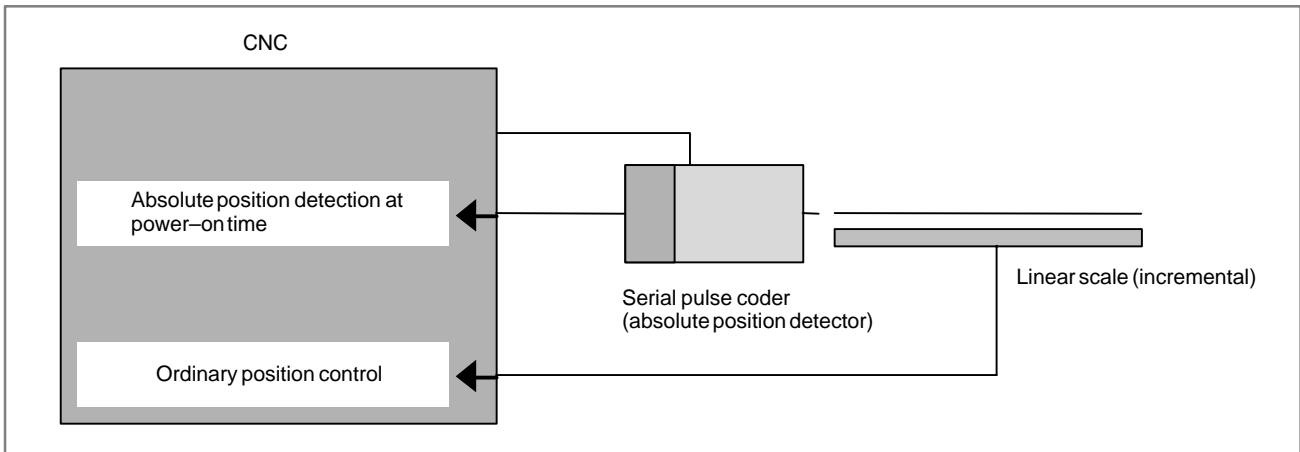

Fig. 1.4.4 System using tentative absolute coordinate system setting

Parameter

	#7	#6	#5	#4	#3	#2	#1	#0
1801					INA			

[Data type] Bit

INA Specifies whether to perform absolute position communication for re-setting up the machine position at a reset after a servo alarm other than alarm 413 (LSI overflow), 416, 445, 446, or 447 (broken-wire alarm) occurs in a system that uses an absolute position detector, as follows:

- 0 : To perform.
- 1 : Not to perform.

NOTE

- 1 If INA = 0 in a system that uses tentative absolute coordinate system setting, the machine position is approximate after a servo alarm other than 413, 416, 445, 446, or 447 is reset, because it has been re-set up using data received from the built-in absolute position coder.
- 2 When a reset is performed after a servo alarm 413, 416, 445, 446, or 447 occurs, absolute position communication for re-setting up the machine position always takes place.

	#7	#6	#5	#4	#3	#2	#1	#0
1815			APCx				OPTx	

[Data type] Bit axis

OPTx Specifies whether to use a separate position detector, as follows:

- 0 : Not to use.
- 1 : To use.

APCx Specifies whether to use a absolute position detector, as follows:

- 0 : Not to use.
- 1 : To use.

NOTE

- 1 When using tentative absolute coordinate system setting, set both OPTx and APCx to 1.
- 2 After setting any of these parameters, turn the power off then on again so that the setting will take effect.

1874	Flexible feed gear numerator for built-in position detector
1875	Flexible feed gear denominator for built-in position detector

[Data type] Word axis

[Valid data range] 1 to 32,767

Specifies a flexible feed gear for a built-in position detector for each axis when using tentative coordinate system setting, according to the following expression:

$$\frac{\text{NO.1874}}{\text{NO.1875}} = \frac{\text{Number of position feedback pulses per motor revolution}}{1,000,000}$$

NOTE

- 1 These parameters can be used also in a system that uses the Inductosyn.
- 2 After setting any of these parameters, turn the power off then on again so that the setting will take effect.

	#7	#6	#5	#4	#3	#2	#1	#0
2011	XIAX							

[Data type] Bit axis

INI Specifies whether to enable tentative absolute coordinate system setting, as follows:

- 0 : To disable.
- 1 : To enable.

NOTE

Using tentative absolute coordinate system setting requires setting bit 1 (OPTx) of parameter No. 1815, bit 5 (APCx) of parameter No. 1815, parameter No. 1874, and parameter No. 1875.

1.5 SETTINGS RELATED WITH COORDINATE SYSTEMS

1.5.1 Machine Coordinate System

General

Machine coordinate system is a coordinate system set with a zero point proper to the machine system.

A coordinate system in which the reference position becomes the parameter-preset (No. 1240) coordinate value when manual reference position return is performed, is set. With G53 command, the machine coordinate system is selected and the axis can be moved at rapid traverse to the position expressed by the machine coordinates.

High-speed G53 function

This function enables the inter-rapid traverse block overlap function between machine coordinate system select command (G53) and positioning (rapid traverse) command (G00) blocks and allows the next rapid traverse command (G00) to be executed at the end of the machine coordinate system select command (G53) without decelerating to a stop. This way, high-speed positioning becomes possible even when the machine coordinate system select command (G53) is used.

Specifying P1 in the G53 block enables the high-speed G53 function.

G53 IP_ P1;

G53: Machine coordinate system select command G code
(00 group)

IP_: End-point dimension word

P1: Enable high-speed G53 function

Parameter

1240	Coordinate value of the reference position on each axis in the machine coordinate system
------	--

NOTE

After setting this parameter, turn the power off then on again so that the setting will take effect.

[Data type] Two-word axis

[Unit of data]	Increment system	IS-A	IS-B	IS-C	Unit
	Metric machine	0.01	0.001	0.0001	mm
	Inch machine	0.001	0.0001	0.00001	inch
	Rotation axis	0.01	0.001	0.0001	deg

[Valid data range] –99999999 to 99999999

Set the coordinate values of the reference positions in the machine coordinate system.

1722	Rapid traverse deceleration rate at inter-rapid traverse block overlap
------	--

[Data type] Byte axis

[Unit of data] %

[Valid data range] 0 to 100

If a high-speed G53 command (G53 P1) block is followed by a rapid traverse block, the latter block (rapid traverse) is executed after the feedrate specified for each axis in the G53 P1 block has decreased to the deceleration rate specified in this parameter.

NOTE

- 1 Enabling the high-speed G53 function does not require setting the RTO parameter (bit 4 of parameter No. 1601) for enabling inter-rapid traverse block overlap to 1.
- 2 If the RTO parameter (bit 4 of parameter No. 1601) is set to 1, a value specified in parameter No. 1722 is used also for ordinary inter-rapid traverse block overlap.

Warning

WARNING

Since the machine coordinate system must be set before the G53 command is specified, at least one manual reference position return or automatic reference position return by the G28 command must be performed after the power is turned on. This is not necessary when an absolute-position detector is attached.

Reference item

Series 16i/18i/160i/180i/ 160is/180is	OPERATOR'S MANUAL (For Machining Center) (B-63534EN)	II.7.1	MACHINE COORDINATE SYSTEM
	OPERATOR'S MANUAL (For Lathe) (B-63524EN)	II.7.1	MACHINE COORDINATE SYSTEM
Series 21i/210i/210is	OPERATOR'S MANUAL (For Machining Center) (B-63614EN)	II.7.1	MACHINE COORDINATE SYSTEM
	OPERATOR'S MANUAL (For Lathe) (B-63604EN)	II.7.1	MACHINE COORDINATE SYSTEM
Series 20i	OPERATOR'S MANUAL (For Manual Milling Machine) (B-64204EN)	II.7.1	MACHINE COORDINATE SYSTEM
	OPERATOR'S MANUAL (For Manual Lathes) (B-64194EN)	II.7.1	MACHINE COORDINATE SYS- TEM

1.5.2 Workpiece Coordinate System/Addition of Workpiece Coordinate System Pair

General

A coordinate system used for machining a workpiece is referred to as a workpiece coordinate system. A workpiece coordinate system is to be set with the CNC beforehand (setting a workpiece coordinate system). A machining program sets a workpiece coordinate system (selecting a workpiece coordinate system). A set workpiece coordinate system can be changed by shifting its origin (changing a workpiece coordinate system).

**Setting a workpiece
coordinate system**

A workpiece coordinate system can be set using one of four methods:

(1) Method using G92 (G50 for G code system A)

A workpiece coordinate system is set by specifying a value after G92 (G50) in the program.

(2) Automatic setting

If bit 0 (ZPR) of parameter No. 1201 is set beforehand, a workpiece coordinate system is automatically set when manual reference position return is performed.

This method can be used when no option is specified for the workpiece coordinate system.

(3) Method of using G54 to G59

Six workpiece coordinate systems are set in advance, using the MDI panel, and the workpiece coordinate system to be used is selected using program commands G54 to G59.

(4) Method of specifying the workpiece coordinate system counter

If the WKINC parameter (bit 4 of parameter No. 3108) has been set, pressing an axis address and the [INP.C.] soft key on the workpiece coordinate system screen in succession causes the relative coordinate value of the specified axis to be set as workpiece coordinate system data at the cursor position.

Selecting a workpiece coordinate system

The user can choose from set workpiece coordinate systems as described below.

(1) Selecting a workpiece coordinate system set by G92 (G50) or automatic workpiece coordinate system setting

Once a workpiece coordinate system is selected, absolute commands work with the workpiece coordinate system.

(2) Choosing from six workpiece coordinate systems set using the MDI panel

By specifying a G code from G54 to G59, one of the workpiece coordinate systems 1 to 6 can be selected.

- G54 Workpiece coordinate system 1
- G55 Workpiece coordinate system 2
- G56 Workpiece coordinate system 3
- G57 Workpiece coordinate system 4
- G58 Workpiece coordinate system 5
- G59 Workpiece coordinate system 6

Workpiece coordinate system 1 to 6 are established after reference position return after the power is turned on. When the power is turned on, G54 coordinate system is selected as default.

Changing workpiece coordinate system

The six workpiece coordinate systems specified with G54 to G59 can be changed by changing an external workpiece zero point offset value or workpiece zero point offset value.

Three methods are available to change an external workpiece zero point offset value or workpiece zero point offset value.

- (1) Inputting from the MDI panel
- (2) Programming by G10 or G92 (G50)
- (3) Using external data input (refer to 15.2)

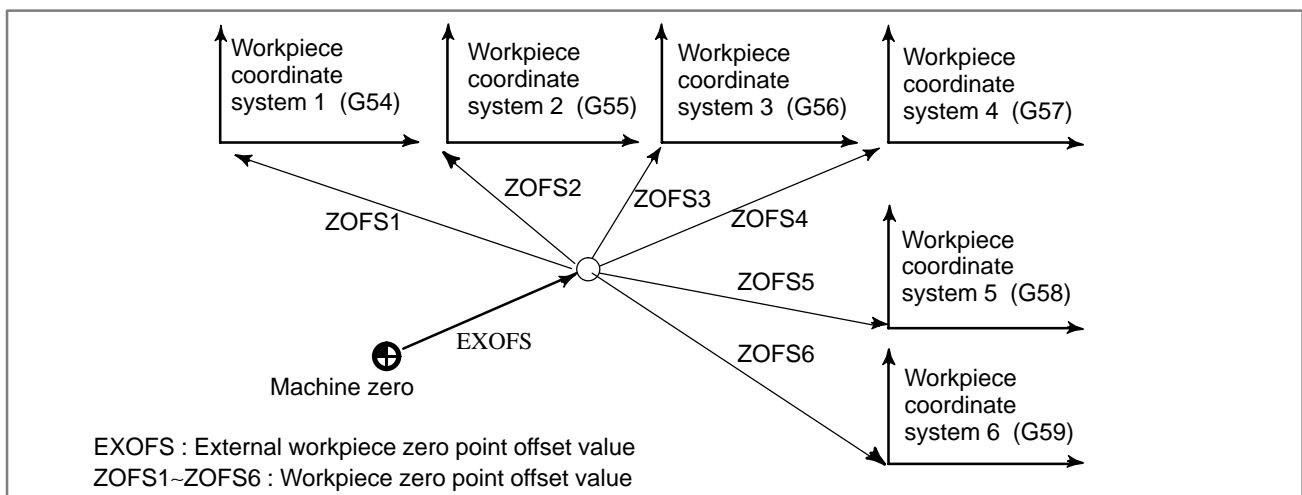

Changing an external workpiece zero point offset value or workpiece zero point offset value

Workpiece coordinate system shift (T series)

When the coordinate system actually set by the G92 (G50) command or the automatic coordinate system setting deviates from the programmed workpiece coordinate, the set coordinate system can be shifted. Set the desired shift amount in the workpiece coordinate system shift memory.

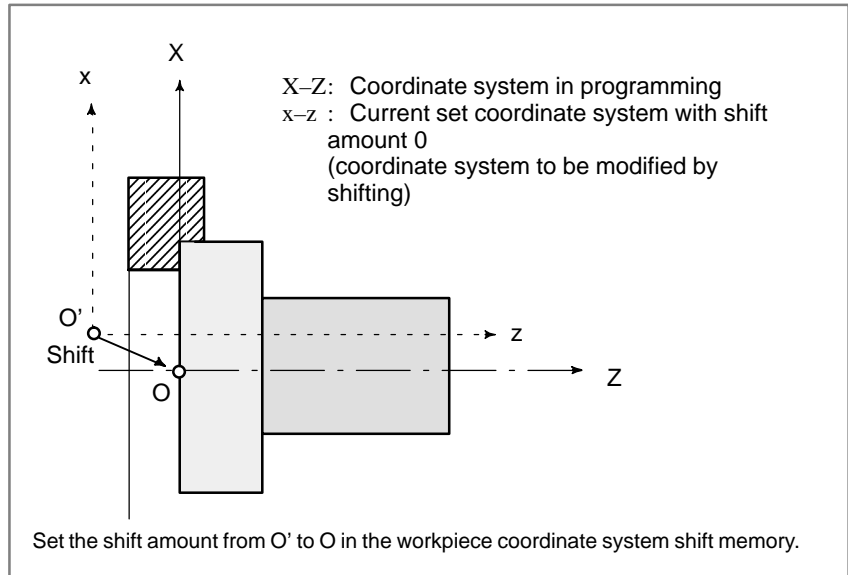

Workpiece Coordinate System shift

Addition of workpiece coordinate system pair (M series)

Besides the six workpiece coordinate systems (standard workpiece coordinate systems) selectable with G54 to G59, 48 or 300 additional workpiece coordinate systems (additional workpiece coordinate systems) can be used.

Parameter

	#7	#6	#5	#4	#3	#2	#1	#0
1201			AWK				ZPI	ZPR

[Data type] Bit

ZPR Automatic setting of a coordinate system when the manual reference position return is performed

0 : Not set automatically

1 : Set automatically

NOTE

If a workpiece coordinate system option is available, automatic coordinate system setting is not performed. Whenever manual reference position return is performed, the workpiece coordinate system is established according to the workpiece origin offset (parameter Nos. 1220 to 1226).

ZPI Coordinates at the reference position when a coordinate system is set automatically

0 : Value set in parameter No. 1250 is used.

1 : For input in mm, the value set in parameter 1250 is used, or for input in inches, the value set in parameter No. 1251 is used.

AWK Action taken after the workpiece zero point offset value is changed

0 : The absolute coordinate value is changed when the first automatic operation is performed.

1 : The absolute coordinate value is changed immediately.(If automatic operation is not in the start-up sequence)

NOTE

In either case, the change becomes effective when the next block is buffered.

	#7	#6	#5	#4	#3	#2	#1	#0
1202						G50	EWS	EWD

[Data type] Bit

EWD The shift direction of the workpiece coordinate system is:

0 : The direction specified by the external workpiece zero point offset value

1 : In the opposite direction to that specified by the external workpiece zero point offset value

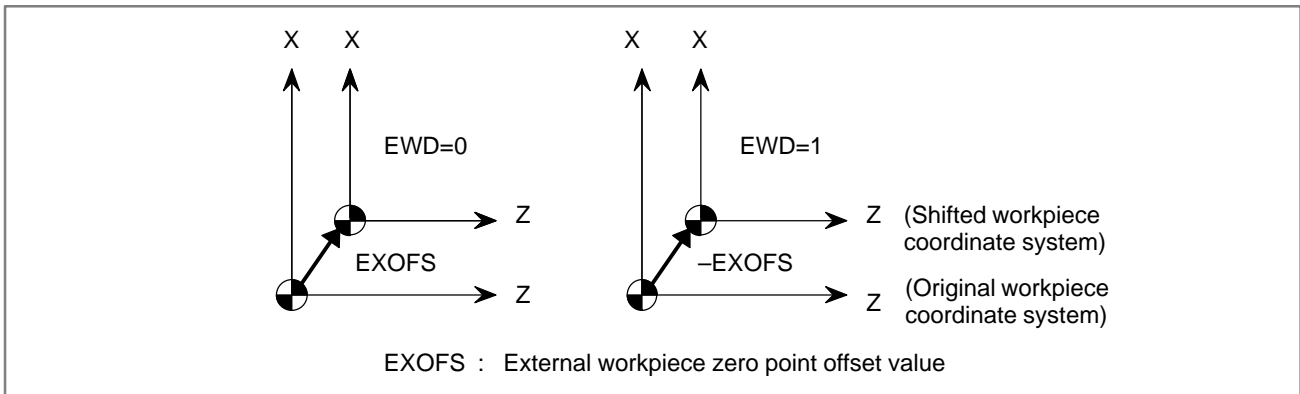

EWS Shift value of the workpiece coordinate system and external workpiece zero point offset value are

0 : Stored in the separate memory areas.

1 : Stored in the same memory area, that is, the shift and the offset values are the same.

G50 When the CNC has commands G54 to G59 specifying workpiece coordinate systems (optional function), if the G50 command for setting a coordinate system (or the G92 command in G command system B or C) is specified,

0 : The G50 (or G92) command is executed without an alarm.

1 : P/S alarm No. 010 is issued and the G50 (or G92) command is not executed.

1220	External workpiece zero point offset value
------	--

[Data type] Two-word axis

[Unit of data]	Input increment	IS-A	IS-B	IS-C	Unit
	Linear axis (input in mm)	0.01	0.001	0.0001	mm
	Linear axis (input in inches)	0.001	0.0001	0.00001	inch
	Rotation axis	0.01	0.001	0.0001	deg

[Valid data range] -99999999 to 99999999

This is one of the parameters that give the position of workpiece coordinate system (G54 to G59). It gives an offset of the workpiece zero point common to all workpiece coordinate systems. In general, the offset varies depending on the workpiece coordinate systems. The parameter value can also be set from the PMC by using the external data input function.

1221	Workpiece zero point offset value in workpiece coordinate system1 (G54)
1222	Workpiece zero point offset value in workpiece coordinate system2 (G55)
1223	Workpiece zero point offset value in workpiece coordinate system3 (G56)
1224	Workpiece zero point offset value in workpiece coordinate system4 (G57)
1225	Workpiece zero point offset value in workpiece coordinate system5 (G58)
1226	Workpiece zero point offset value in workpiece coordinate system6 (G59)

[Data type] Two-word axis

[Unit of data]	Input increment	IS-A	IS-B	IS-C	Unit
	Linear axis (input in mm)	0.01	0.001	0.0001	mm
	Linear axis (input in inches)	0.001	0.0001	0.00001	inch
	Rotation axis	0.01	0.001	0.0001	deg

[Valid data range] -99999999 to 99999999

The workpiece zero point offset values in workpiece coordinate systems 1 to 6 (G54 to G59) are set.

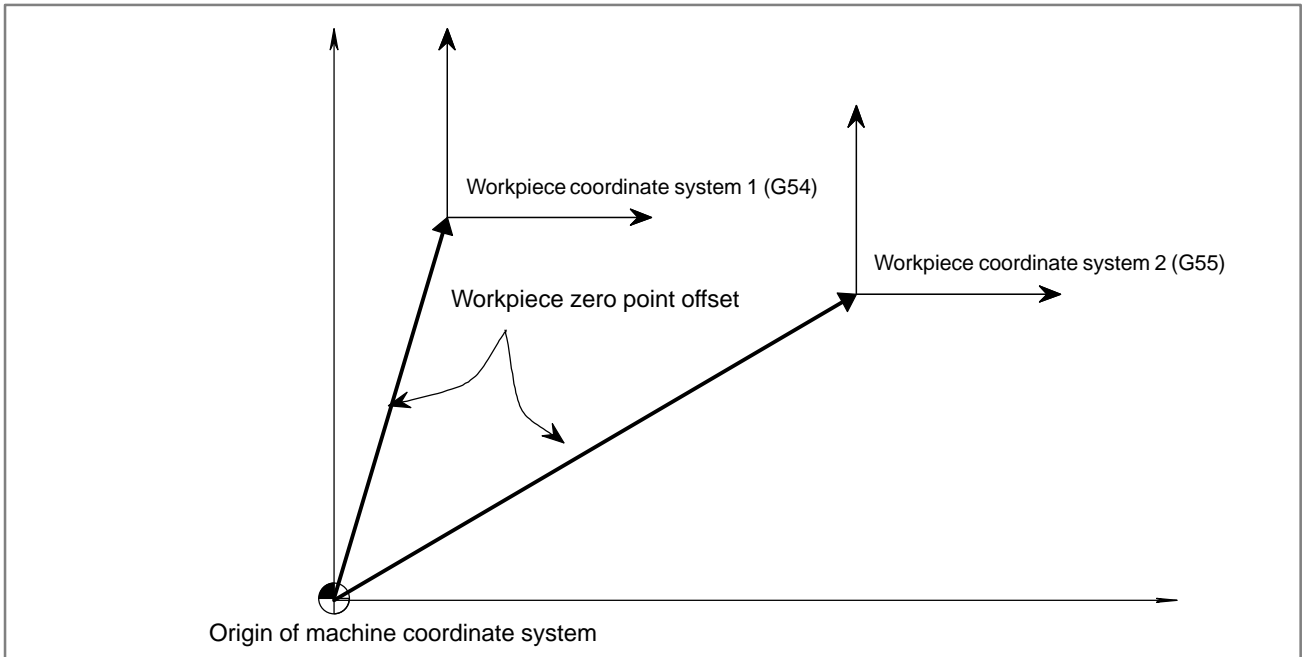

1250	Coordinate value of the reference position used when automatic coordinate system setting is performed
------	---

[Data type] Two-word axis

[Unit of data]	Input increment	IS-A	IS-B	IS-C	Unit
	Linear axis (input in mm)	0.01	0.001	0.0001	mm
	Linear axis (input in inches)	0.001	0.0001	0.00001	inch
	Rotation axis	0.01	0.001	0.0001	deg

[Valid data range] -99999999 to 99999999

Set the coordinate value of the reference position on each axis to be used for setting a coordinate system automatically.

1251	Coordinate value of the reference position used when automatic coordinate system setting is performed with inch input
------	---

[Data type] Two-word axis

[Unit of data]	Input increment	IS-A	IS-B	IS-C	Unit
	Linear axis (input in inches)	0.001	0.0001	0.00001	inch

[Valid data range] -99999999 to 99999999

Set the coordinate value of the reference position on each axis to be used for setting a coordinate system automatically when input is performed in inches.

NOTE
This parameter is valid when ZPI in parameter 1201 is set to 1.

	#7	#6	#5	#4	#3	#2	#1	#0
3108				WCI				

[Data type] Bit

WCI On the workpiece coordinate system screen, a counter input is:

0 : Disabled.

1 : Enabled.

Reference item

Series 16i/18i/160i/180i/ 160is/180is	OPERATOR'S MANUAL (For Machining Center) (B-63534EN)	II.7.2	WORKPIECE COORDINATE SYSTEM
	OPERATOR'S MANUAL (For Lathe) (B-63524EN)	II.7.2	WORKPIECE COORDINATE SYSTEM
Series 21i/210i/210is	OPERATOR'S MANUAL (For Machining Center) (B-63614EN)	II.7.2	WORKPIECE COORDINATE SYSTEM
	OPERATOR'S MANUAL (For Lathe) (B-63604EN)	II.7.2	WORKPIECE COORDINATE SYSTEM
Series 20i	OPERATOR'S MANUAL (For Manual Milling Machine) (B-64204EN)	II.7.2	WORKPIECE COORDINATE SYSTEM

1.5.3 Rotary Axis Roll Over

General

The roll-over function prevents coordinates for the rotation axis from overflowing. The roll-over function is enabled by setting bit 0 (ROAx) of parameter 1008 to 1.

For an incremental command, the tool moves the angle specified in the command. For an absolute command, the coordinates after the tool has moved are values rounded by the angle corresponding to one rotation set in parameter No. 1260. The tool moves in the direction in which the final coordinates are closest when bit 1 (RABx) of parameter No. 1008 is set to 0. Displayed values for relative coordinates are also rounded by the angle corresponding to one rotation when bit 2 (RRLx) of parameter No. 1008 is set to 1.

Parameter

	#7	#6	#5	#4	#3	#2	#1	#0
1006							ROSx	ROTx

NOTE

After setting this parameter, turn the power off then on again so that the setting will take effect.

[Data type] Bit axis

ROT_x, ROS_x Setting linear or rotation axis

ROSx	ROTx	Description
0	0	Linear axis (1) Inch/metric conversion is done. (2) All coordinate values are linear axis type. (Not rounded in 0 to 360°) (3) Stored pitch error compensation is linear axis type (Refer to parameter No. 3624)
0	1	Rotation axis (A Type) (1) Inch/metric conversion is not done. (2) Machine coordinate values are rounded in 0 to 360°. Absolute coordinate values and relative coordinate values are rounded or not rounded by parameter No. 1008 #0 and #2. (3) Stored pitch error compensation is the rotation type. (Refer to parameter No. 3624) (4) Automatic reference position return (G28, G30) is done in the reference position return direction and the move amount does not exceed one rotation.
1	0	Setting is invalid (unused)
1	1	Rotation axis (B type) (1) Inch/metric conversion is not done. (2) Machine coordinate values, absolute coordinate values and relative coordinate values are linear axis type. (Is not rounded in 0 to 360°) (3) Stored pitch error compensation is linear axis type (Refer to parameter No. 3624) (4) The rotation axis roll over function and index table indexing function (M series) cannot be used.

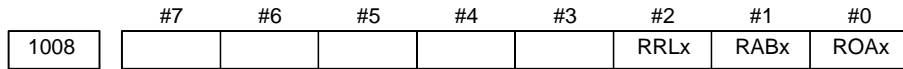

NOTE
After setting this parameter, turn the power off then on again so that the setting will take effect.

[Data type] Bit axis

ROAx The roll-over function of a rotation axis is
0 : Invalid
1 : Valid

NOTE
ROAx specifies the function only for a rotation axis (for which ROTx, #0 of parameter No. 1006, is set to 1)

RABx In the absolute commands, the axis rotates in the direction
0 : In which the distance to the target is shorter.
1 : Specified by the sign of command value.

NOTE
RABx is valid only when ROAx is 1.

RRLx Relative coordinates are
0 : Not rounded by the amount of the shift per one rotation
1 : Rounded by the amount of the shift per one rotation

NOTE
1 RRLx is valid only when ROAx is 1.
2 Assign the amount of the shift per one rotation in parameter No. 1260.

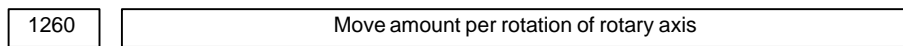

NOTE
When this parameter is changed, turn off the power before continuing operation.

[Data type] Two-word axis

[Unit of data]	Increment system	IS-A	IS-B	IS-C	Unit
	Unit of data	0.01	0.001	0.0001	deg
	Standard setting value	36000	360000	3600000	

[Valid data range] 1000 to 99999999
Set move amount per rotation of rotation axis.

Note**NOTE**

This function cannot be used together with the indexing function of the index table (M series).

Reference item

Series 16i/18i/160i/180i/ 160is/180is	OPERATOR'S MANUAL (For Machining Center) (B-63534EN)	II.20.2	ROTARY AXIS ROLL-OVER
	OPERATOR'S MANUAL (For Lathe) (B-63524EN)	II.19.2	ROTARY AXIS ROLL-OVER
Series 21i/210i/210is	OPERATOR'S MANUAL (For Machining Center) (B-63614EN)	II.20.2	ROTARY AXIS ROLL-OVER
	OPERATOR'S MANUAL (For Lathe) (B-63604EN)	II.19.2	ROTARY AXIS ROLL-OVER
Series 20i	OPERATOR'S MANUAL (For Manual Milling Machine) (B-64204EN)	II.18.1	ROTARY AXIS ROLL-OVER

1.5.4 Rotary Table Dynamic Fixture Offset (M Series)

General

Suppose that a workpiece has been set on the rotary table, its position has been measured, and the workpiece coordinate system has been set up. Once the rotary table rotates before cutting begins, it has conventionally become necessary to measure the workpiece position and set up the workpiece coordinate system again. With this function, setting the workpiece position with a reference fixture offset value at a certain rotary table position causes the fixture offset value to be calculated automatically from the angle of the rotary table and a workpiece coordinate system to be generated according to the calculated value even if the rotary table rotates. For this reason, once the workpiece position is set with a reference fixture offset value, the workpiece coordinate system can be dynamically preserved in accordance with the position of the rotary table no matter which position the rotary table is situated at. The origin of the workpiece coordinate system is obtained by adding the workpiece zero point offset value to the fixture offset value.

Data setting

- 1) Three-parameter set for specifying a rotation axis and two linear axes that form a rotation plane

The first parameter in the parameter set is a rotation axis number, and the second and third parameters are linear axis numbers. The two linear axes are arranged in such a sequence that a rotation from the positive linear axis specified in the second parameter to that specified in the third parameter corresponds to the positive rotation of the rotation axis specified in the first parameter.

Example) Let us examine a right-handed (X, Y, Z) coordinate system and a four-axis machine in which the C-axis is defined as a rotation axis whose positive rotation around the Z-axis is counterclockwise as viewed from the positive direction of the Z-axis toward the negative direction.

The parameters specify as follows:

First parameter: 4 (C-axis)

Second parameter: 1 (X-axis)

Third parameter: 2 (Y-axis)

Up to three sets of parameters like those listed above can be set up. First, a fixture offset value is obtained by performing calculation on the rotation axis specified in the first parameter set. Calculation based on the second and third sets is performed on the result.

If there are two or more rotation axes, and the rotation plane of a rotation axis varies with rotation around another rotation axis, it is necessary to fix the rotation plane when the rotation axis is at 0°.

- 2) Reference angle for the rotation axis and the corresponding reference fixture offset value

Set up a certain position (reference angle) for the rotation axis and the corresponding fixture offset value.

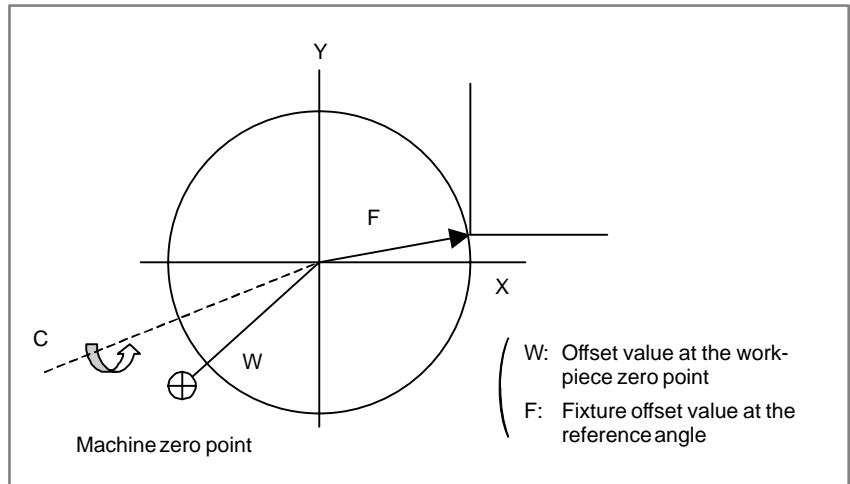

The setting is carried out on the fixture offset screen. (See Fig. 2.1.5.) There are eight sets.

- 3) Bit 0 of parameter No. 7575 for enabling/disabling a fixture offset for an individual axis

Set, to 1, the parameter for the axis whose fixture offset is to be enabled.

This is not needed for rotation axes.

- 4) Fixture offset type (bit 0 of parameter No. 7570)

If a fixture offset vector varies (if the G54.2 command is issued or the rotation axis is moved when the G54.2 command is being issued), specify whether to move the rotation axis by a vector change, as follows:

- 0: To move.
(The workpiece coordinates of the current position do not change, but the machine coordinates change.)
- 1: Not to move.
(The workpiece coordinates of the current position change, but the machine coordinates do not change.)

Format

G54.2 Pn;

Pn: Fixture offset value number (1 to 8)
If n = 0, the fixture offset value is disabled.

Obtain a fixture offset value from the current rotation angle and the data specified with n, and enable the fixture offset value.

If the rotation axis related to the fixture offset moves in the G54.2 mode, vector calculation is carried out again.

Operation at reset

The CLR parameter (bit 6 of parameter No. 3402) and C23 parameter (bit 7 of parameter No. 3408) specify whether to cancel the fixture offset when a reset occurs.

If CLR = 0 or if CLR = 1 and C23 = 1, the vector is saved before the reset occurs.

If CLR = 1 and C23 = 0, the vector is cleared. In this case, however, the machine does not move by a cleared vector regardless of the FTP parameter (bit 0 of parameter No. 7570).

Program example and operation

Assume parameters and data are set as follows:

Parameter 7580 = 4 (C-axis)
 7581 = 1 (X-axis) Bit 0 of 7575 (X) = 1 (X-axis enabled)
 7582 = 2 (Y-axis) Bit 0 of 7575 (Y) = 1 (Y-axis enabled)
 7583 to 7588 = 0

Bit 0 of 7570 = 0 (Data enclosed in [] applies when bit 0 of 7570 is 1 (for shift type))

Data if n = 1

C = 180.0 (reference angle)
 X = -10.0
 Y = 0.0

The result of the above settings is as follows:

Coordinate value Program	Position in the workpiece coordinate system (ABSOLUTE)			Position in the machine coordinate system (MACHINE)			Fixture offset value		
	X	Y	C	X	Y	C	X	Y	C
N1 G90 G00 X0 Y0 C90.;	0	0	90.	0	0	90.	0	0	0.
N2 G54.2 P1;	0	0	90.	0	10	90.	0	10.	0
	[0	-10.	90.]	[0	0.	90.]	[0	10.	0]
N3 G01 X10. Y2. F100.;	10.	2.	90.	10.	12.	90.	0	10.	0
N4 G02 X2. Y10. R10.;	2.	10.	90.	2.	20.	90.	0	10.	0
N5 G01 X0 Y0;	0	0	90.	0	10	90.	0	10.	0
...									

Machine movement

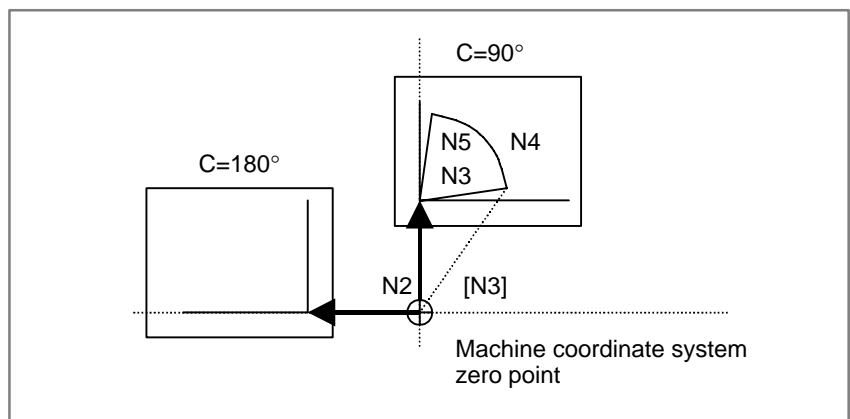

If block N2 issues G54.2P1, a vector (X = 0, Y = 10.0) for the fixture offset is calculated. This vector is treated in the same manner as for the offset value at the workpiece zero point, and at this point of time, the current position in the workpiece coordinate system is (X = 0, Y = -10.0).

If bit 1 of parameter No. 7570 is 0, the machine actually moves further by this vector, resulting in the current position in the workpiece coordinate system becoming the previous value (X = 0, Y = 0).

Fixture offset screen

The fixture offset screen is either a fixture offset (ACT) screen for verifying the currently selected fixture offset value or a fixture offset screen for setting and verifying eight fixture offset value sets.

1) Fixture offset (ACT) screen

FIXTURE OFFSET (ACT)						
ACT(P=01)						
X	0.000					
Y	0.000					
Z	0.000					
C	0.000					
B	0.000					
A	0.000					
<table border="1" style="width: 100%; height: 20px;"> <tr> <td style="width: 20%;"></td> <td style="width: 20%;"></td> <td style="width: 20%;"></td> <td style="width: 20%;"></td> <td style="width: 20%;"></td> </tr> </table>						

This screen displays the currently selected fixture offset number (P) and fixture offset vector.

2) Fixture offset screen

FIXTURE OFFSET								
	NO.01		NO.02					
X	0.000	X	0.000					
Y	0.000	Y	0.000					
Z	0.000	Z	0.000					
C	0.000	C	0.000					
B	0.000	B	0.000					
A	0.000	A	0.000					
<table border="1" style="width: 100%; height: 20px;"> <tr> <td style="width: 25%;">NO.SRH</td> <td style="width: 25%;"></td> <td style="width: 25%;">PUNCH</td> <td style="width: 25%;">+INPUT</td> <td style="width: 25%;">INPUT</td> </tr> </table>				NO.SRH		PUNCH	+INPUT	INPUT
NO.SRH		PUNCH	+INPUT	INPUT				

On this screen, the cursor is set to the desired location, using the page key, cursor key, and the [NO.SRH] soft key, and a value is entered at the cursor position, using the INPUT key on the MDI or the [INPUT] and [+INPUT] soft keys.

Fixture offset input/output

Program setting and external input/output can be performed as stated below:

- 1) Setting a reference fixture offset value, using G10

G10L21 Pn IP; (n: Fixture offset number
IP: Reference fixture offset value or reference angle for an individual axis

The command shown above can be used to set a reference fixture offset value or reference angle in a program.

If the program is executed in the G90 mode, a value specified in the program is set up without being modified.

If the program is executed in the G91 mode, a value specified before the execution is added to a value specified in the program.

NOTE

The programmable data input (G10) option is needed.

- 2) Reading/writing based on a custom macro system variable

The following system variable number can be used to read and write a reference fixture offset value or a reference angle. However, it is impossible to write to a system variable area (5500 to 5508) if $n = 0$.

System variable number = $5500 + 20 * n + m$

n: Fixture offset number (1 to 8)

The current offset is used if $n = 0$.

m: Axis number (1 to the number of controlled axes)

System variable 5500 can be used to read a selected offset number.

NOTE

The custom macro option is needed.

- 3) Reading/writing through the PMC window and OpenCNC

The window function can be used to read/write a custom macro system variable having the same number as in 2).

NOTE

The custom macro option is needed.

- 4) Output to external units

Selecting [PUNCH] on the fixture offset screen enables outputting to external units such as a floppy cassette and memory card. Output data is in the G10 format with no program number. To enter the program, register and execute it.

NOTE

The reader/punch interface and programmable data input (G10) options are needed.

Method of calculating fixture offset values

1) Relationships between rotation and linear axes
(when A = 0 and B = 0)

First set: 5 (B-axis), 1 (X-axis), 3 (Z-axis)

First set: 4 (A-axis), 3 (Z-axis), 2 (Y-axis)

First set: 0, 0, 0 (Z-axis)

2) Reference angle and reference fixture offset value

X: F0X

Y: F0Y

Z: F0Z

A: ϕ_0

B: θ_0 If the above data is set up, the method of calculating fixture offset values is as follows:

- O: Rotary table center
- W: Workpiece zero point offset value
- F0: Fixture offset value for A = ϕ_0 and B = θ_0
- FA: Fixture offset value for A = 0 and B = 0
- F1: Fixture offset value for A = 0 and B = θ
- F: Fixture offset value for A = ϕ and B = θ

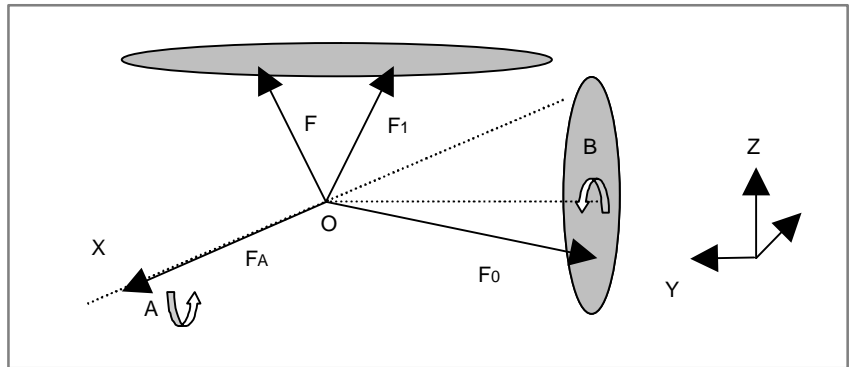

$$F_A = (F_{AX}, F_{AY}, F_{AZ})$$

$$F_1 = (F_{1X}, F_{1Y}, F_{1Z})$$

$$F = (F_X, F_Y, F_Z) \quad \text{Assuming the above, the following are obtained:}$$

$$\begin{matrix} F_{AX} = \\ F_{AY} = \\ F_{AZ} = \end{matrix} \begin{pmatrix} \cos(-\theta_0) & \cos(-\theta_0) & -\sin(-\theta_0) \\ 0 & 1 & 0 \\ \sin(-\theta_0) & 0 & \cos(-\theta_0) \end{pmatrix} \begin{pmatrix} 1 & 0 & 0 \\ 0 & \cos(\phi_0) & -\sin(\phi_0) \\ 0 & \sin(\phi_0) & \cos(\phi_0) \end{pmatrix} \begin{pmatrix} F_{0X} \\ F_{0Y} \\ F_{0Z} \end{pmatrix}$$

$$\begin{matrix} F_{1X} = \\ F_{1Y} = \\ F_{1Z} = \end{matrix} \begin{pmatrix} \cos(\theta) & 0 & -\sin(\theta) \\ 0 & 1 & 0 \\ \sin(\theta) & 0 & \cos(\theta) \end{pmatrix} \begin{pmatrix} F_{0X} \\ F_{0Y} \\ F_{0Z} \end{pmatrix}$$

$$\begin{matrix} F_X = \\ F_Y = \\ F_Z = \end{matrix} \begin{pmatrix} 1 & 0 & 0 \\ 0 & \cos(-\phi) & -\sin(-\phi) \\ 0 & \sin(-\phi) & \cos(-\phi) \end{pmatrix} \begin{pmatrix} F_{1X} \\ F_{1Y} \\ F_{1Z} \end{pmatrix}$$

Caution

CAUTION

- 1 If parameter Nos. 7580 to 7588 or a reference fixture offset value is changed in the G54.2 mode, the new setting takes effect after the next G54.2Pn command is issued.
- 2 If changing the fixture offset vector causes movement, the same mode and movement speed as for the modal setting of group 01 take effect except for modes (G02, G03, etc.) other than G00 or G01, in which case movement occurs temporarily in the G01 mode.
- 3 If an automatic operation is stopped, for example, with an SBK stop in the G54.2 mode, and the rotation axis is moved manually, the fixture offset vector does not change. If a rotation axis command or G54.2 command is issued during an automatic operation or MDI operation, vector calculation is carried out. If a rotation axis command is issued in the incremental mode (G91) after manual intervention is made by setting the manual absolute switch to ON, however, vector calculation is carried out using coordinate values to which the manual intervention has been reflected, though this is different from the specification of the FS15.
- 4 If a block specifies rotation axis movement related to the fixture offset in the G54.2 mode, vector calculation is carried out at the end of the block, using the coordinate values of the rotation axis, and movement is made to a position specified in the workpiece coordinate system indicated by the vector.
- 5 Fixture offset calculation uses rotation coordinate values in the workpiece coordinate system. If an offset such as a tool offset is in effect, the coordinate values that existed before the offset was applied are used.
- 6 If the following commands are issued for the rotation axis in the G54.2 mode, vector calculation is not carried out for the fixture offset.
 - Machine coordinate system selection (G53)
 - Workpiece coordinate system change (G54 to G59, G54.1, G92, and G52)
 - Reference position return (G27, G28, G29, G30, G30.1)
- 7 No fixture offset rotation axis can be specified to be used with polar coordinate system interpolation (G12.1).
- 8 To use the rotation axis roll-over function, be sure to define a movement amount per rotation axis revolution as 360.
- 9 The following functions cannot be specified in the G54.2 mode:
 - Program restart function
 - Mirror image function
 - Scaling function
 - Coordinate system rotation function
 - High-precision contour control function and AI contour control function
 - Figure copy function

Parameter

7580	Specifying rotation axis to which the fixture offset is to be applied (first set)
7581	Specifying linear axis 1 forming a plane to which the fixture offset is to be applied (first set)
7582	Specifying linear axis 2 forming a plane to which the fixture offset is to be applied (first set)
7583	Specifying rotation axis to which fixture offset is to be applied (second set)
7584	Specifying linear axis 1 forming a plane to which fixture offset is to be applied (second set)
7585	Specifying linear axis 2 forming a plane to which fixture offset is to be applied (second set)
7586	Specifying rotation axis to which fixture offset is to be applied (third set)
7587	Specifying linear axis 1 forming a plane to which fixture offset is to be applied (third set)
7588	Specifying linear axis 2 forming a plane to which fixture offset is to be applied (third set)

[Data type] Byte

[Valid data range] 1, 2, 3, ..., number of controlled axes

Specify a rotation axis and two linear axes (for forming a rotation plane for the rotation axis) to which fixture offset is to be applied. The two linear axes are in such a sequence that a rotation from the positive direction of linear axis 1 to that of linear axis 2 corresponds to the positive rotation of the rotation axis. Up to three sets of these settings can be made. First, a fixture offset value is obtained by performing calculation on the rotation axis specified in the first set of parameters. Calculation based on the second and third sets is performed on the result. If only one or two sets are needed, reset unnecessary rotation axis parameters to 0.

	#7	#6	#5	#4	#3	#2	#1	#0
7570								FTP

[Data type] Bit

FTP Specifies a fixture offset type, as follows:

- 0 : Movement type (movement occurs if the fixture offset changes)
- 1 : Shift type (movement does not occur even if the fixture offset changes)

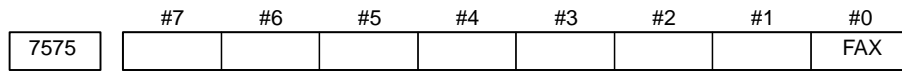

[Data type] Bit axis

FAX Specifies whether to enable the fixture offset for an individual axis.

0 : To disable.

1 : To enable.

Alarm and message

Number	Message	Description
5251	There is an error in the G54.2 parameter.	The fixture offset parameter is incorrect (7580 to 7588).
5252	There is an invalid P code specification in the G54.2 parameter.	The P value for specifying an offset number for the fixture offset is too large. Correct the program.

1.6 SIMPLE SYNCHRONOUS CONTROL

General

A movement along an axis can be executed simply by executing a move command specified for that axis or by synchronizing the movement with another axis. Either of these two types can be selected by means of a signal sent from the machine.

In synchronous operation, that axis for which move commands can be specified is called the master axis, while an axis along which the tool moves in sync with the master axis is called a slave axis.

- **Simple synchronous control for the M series and T series**

The M series and T series support different simple synchronization control functions. One of the greatest differences is that:

<T series> The function can synchronize only automatic operations. It cannot synchronize manual operations. Only one master/slave axis pair can be used.

<M series> The function can synchronize both automatic and manual operations.

The following functions are provided only for the M series:

- Synchronization error check function
- Synchronization compensation function

- **Synchronization error check based on positional deviation (M series)**

Any difference between the servo positional deviation of the master axis and that of the slave axis is monitored constantly. A P/S alarm condition (No. 213) is detected if a limit set in parameter No. 8313 (if only one master/slave axis pair is in sync) or 8323 (if more than one master/slave axis pair is in sync) is exceeded.

- **Synchronization error check based on machine coordinates (M series)**

The function monitors the difference between the machine coordinates on the master and slave axes. If the function detects a difference greater than or equal to a preset value, it stops the machine. This function constantly monitors the difference. Even if the synchronization control signal is erroneously set to 0, thus disabling synchronization control, the function can issue an alarm, stop the machine, and thus prevent damage.

If the detected difference is greater than or equal to the maximum error set in parameter 8314, servo alarm 407 is output.

WARNING

- 1 Before using the synchronization error check function, set identical values for the reference positions of the master and slave axes.
- 2 To clear the alarm, first increase the maximum synchronization error set in parameter 8314, then press the reset key. Next, perform handle operations or other manual operations so that the machine coordinates agree. Then, restore the original value in parameter 8314.
- 3 If an alarm is detected during a synchronous operation, set the signals indicating that a synchronous operation is in progress (G138, G140) to off, then follow the procedure for clearing an alarm.

NOTE

If the synchronization error check function is not used, set parameter 8314 to 0.

- **Synchronization compensation function (M series)**

If the synchronization between the positions of the master and slave axes is lost when the system power is turned off, the function compensates for the difference between them. After performing a follow-up at power on, the function sends compensation pulses to the slave axis to adjust its position such that it agrees with that of the master axis. This function is enabled only when the slave axis of synchronization control supports the absolute-position detection function.

This function, however, cannot be used for rotation axes.

WARNING

- 1 The synchronization compensation function is enabled after reference position returns have been performed. The function is not executed if the parameter is set before reference position returns are performed.
- 2 The synchronization compensation function is not executed when the servo alarm is eliminated.

CAUTION

The synchronization deviation is processed as a position error on the slave axis while at rest. The position error is displayed as diagnostic data 300, in the same units as used to detect the error. If the error exceeds the value set in parameter 8315 (if only one master/slave axis pair is in sync) or 8325 (if more than one master/slave axis pair is in sync), servo alarm 410 is triggered. The alarm can be cleared by pressing the reset key. As the position error for the slave axis remains even after the alarm is cleared, however, the positions must be adjusted.

NOTE

- 1 To use the synchronization compensation function, set the SOF bit, bit 7 of parameter 8301 (if only one master/slave axis pair is in sync) or SOF_x bit, bit 7 of parameter 8303 (if more than one master/slave axis pair is in sync), to 1.
- 2 The synchronization compensation function is also enabled when emergency stop is canceled.

- **Automatic setting of grid positioning (M series)**

To use simple synchronous control, it is necessary to perform reference position return for the master and slave axes. This function causes the CNC to automatically perform reference position return (grid position) for both the master and slave axes in simple synchronization.

[Operating procedure] This procedure can be applied only when one master/slave axis pair is in sync, and when bit 0 (ATE) of parameter No. 8302 is set to 1. If more than one master/slave axis pair is in sync, it is necessary to use parameters ATE_x (bit 0 of parameter No. 8303) and ATS_x (bit 1 of parameter No. 8303).

- 1 Set bit 1 (ATS) of parameter No. 8302 to 1.
- 2 Power off/on.
- 3 Enter REF mode (or JOG mode for reference position setting without dogs), and move along the axis toward the reference position.
- 4 Motion along the master and slave axes stops automatically, and the grid deviation is set in parameter No. 8316. At the same time, bit 1 (ATS) of parameter No. 8302 becomes 0, and a power-off request alarm (No. 000) occurs.
- 5 Switch the power off then back on.
- 6 Perform ordinary reference position return.

NOTE**Parameter setting**

When parameter ATS (bit 1 of parameter No. 8302) or ATS_x (bit 1 of parameter No. 8303) is set, parameter APZ (bit 4 of parameter No. 1815) for the master and slave axes and parameter No. 8316 become 0. If the operator specifies parameter No. 8316 (MDI, G10L50), parameter ATE (bit 0 of parameter No. 8302) becomes 0.

• Torque difference alarm detection (M series)

If the master and slave axes operate independently while simple synchronous control is applied, the machine may be damaged. To prevent this, the torque command difference between the axes is monitored. If the difference is found to be abnormal, an alarm can be issued.

[System configuration]

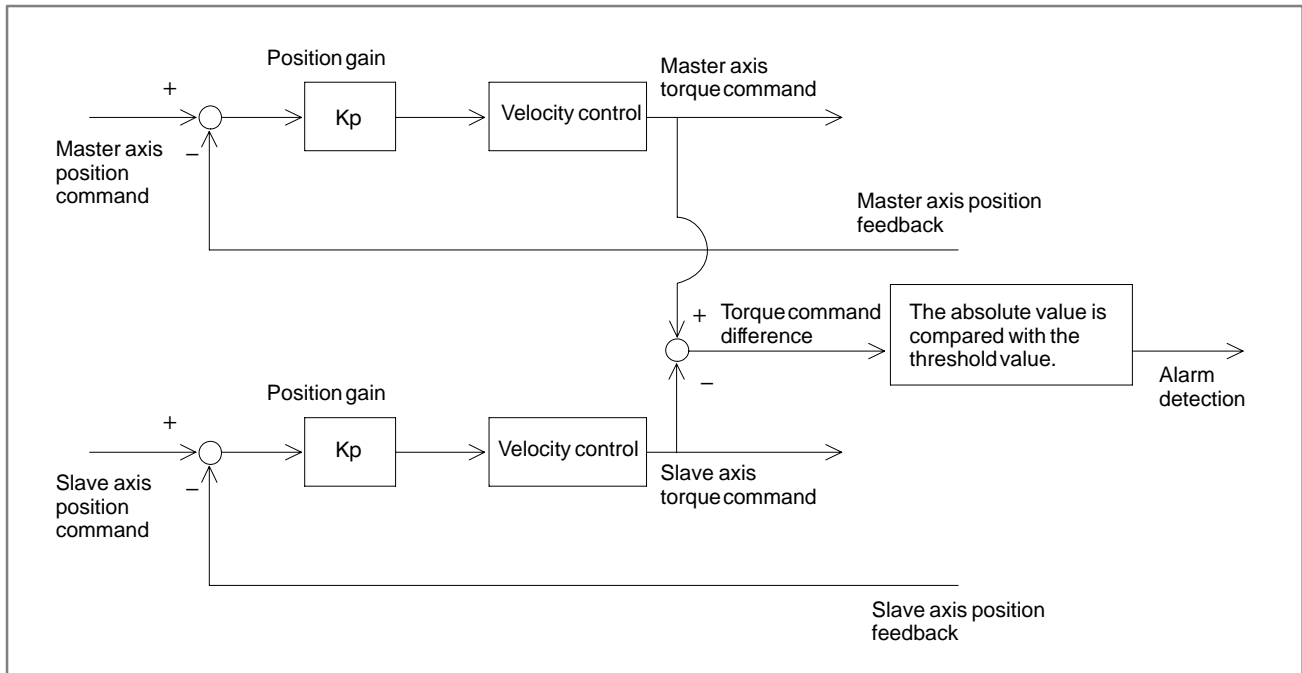

[How to use]

Determine the threshold parameter using the following procedure.

- Set up the following parameters:
 Parameter No. 2031 = 0 : Disable torque difference alarm detection.
 Parameter Nos. 2115 and 2151: Display the absolute value of a torque difference between axes in synchronization on the diagnosis screen. Set the same value for the two axes in simplified synchronization.
 Setting
 Parameter No. 2115 = 0
 Parameter No. 2151 = 178
- Cause the diagnosis screen to appear, using the <SYSTEM> function key → the [DGNOS] soft key.
 The diagnosis screen No. 353 displays the absolute value of a torque difference between the two axes in synchronization.
- Read a maximum of the absolute values of torque differences during a normal operation.
 Set the threshold parameter with the maximum absolute value with some margin allowed.
 If it is difficult to read the absolute values of torque differences on the diagnosis screen, observe the absolute values of torque differences with an oscilloscope, using the following method:
- Set parameter Nos. 2115 and 2151 with:
 Setting
 Parameter No. 2115 = 4
 Parameter No. 2151 = 178

- 5 Connect a check board to observe torque differences.
If an analog check board is used, set the rotary switch of the check board to 1, and observe signals on CH7.
If the oscilloscope is a combined analog/digital model, set the DATA digit for CH1 to 5, and observe signals on CH1.
- 6 Convert the observed value, using the formula $1\text{ V} = 410$ (specified threshold value). Read the maximum value during ordinary operation, and allow an appropriate margin.

[Timing chart]

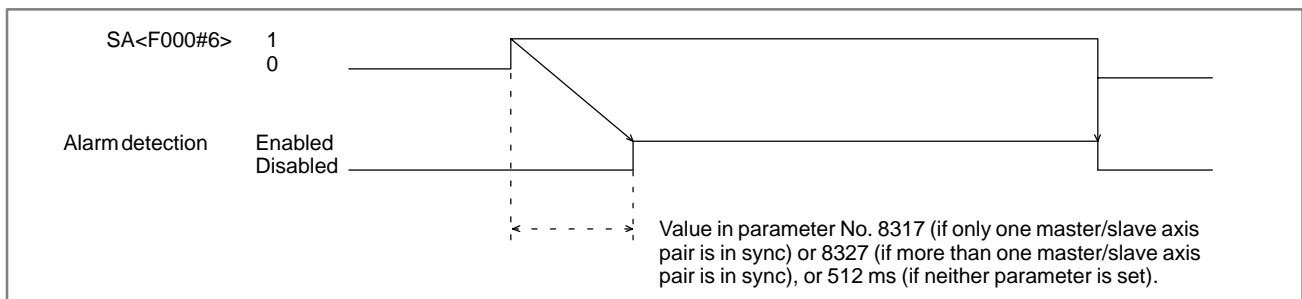

If the servo preparation completed signal SA <F000#6> is 0, torque difference alarm detection is not performed.

The simple synchronous control functions are described separately for the T series and M series in the following explanations.

Signal

<T series and M series>

Signals to select the slave axis for simple synchronous control SYNC1 to SYNC8 <G138>

[Classification] Input signal

[Function] synchronous control is performed for memory or MDI operation. The signal is provided for each controlled axis. The number at the end of the signal name represents the number of the controlled axis.

SYNC 1

1. ... The first axis becomes the slave axis for synchronous control.
2. ... The second axis becomes the slave axis for synchronous control.
3. ... The third axis becomes the slave axis for synchronous control.
- :
- :

[Operation] When the signal is set to 1, the control unit operates as described below:

- During memory or MDI operation, the control unit supplies the move command, specified for the master axis, to both the master and slave axes of synchronous control.

The master axis is specified with a parameter.

<M series>

**Signals for selecting the manual feed axis for simple synchronous control
SYNCJ1 to SYNCJ8
<G140>**

[Classification] Input signal

[Function] synchronous control is performed in jog, handle, or incremental feed mode.

The signal is provided for each controlled axis. The number at the end of the signal name represents the number of the controlled axis.

SYNCJ 1

- 1. ... The first axis becomes the slave axis for synchronous control.
- 2. ... The second axis becomes the slave axis for synchronous control.
- 3. ... The third axis becomes the slave axis for synchronous control.
- :
- :

[Operation] When the signal is set to 1, the control unit operates as described below:

- In jog, handle, or incremental feed mode, the control unit supplies the move command, specified for the master axis, to both the master and slave axes of synchronous control.

The master axis is specified with a parameter.

Signal address

T series

	#7	#6	#5	#4	#3	#2	#1	#0
G138	SYNC8	SYNC7	SYNC6	SYNC5	SYNC4	SYNC3	SYNC2	SYNC1

M series

	#7	#6	#5	#4	#3	#2	#1	#0
G138	SYNC8	SYNC7	SYNC6	SYNC5	SYNC4	SYNC3	SYNC2	SYNC1
G140	SYNCJ8	SYNCJ7	SYNCJ6	SYNCJ5	SYNCJ4	SYNCJ3	SYNCJ2	SYNCJ1

Parameter

T series

1010	Number of CNC-controlled axes
------	-------------------------------

NOTE

When this parameter is set, the power must be turned off before operation is continued.

[Data type] Byte

[Valid data range] 1, 2, 3, ..., the number of controlled axes

Set the maximum number of axes that can be controlled by the CNC.

[Example]

Suppose that the first axis is the X axis, and the second and subsequent axes are the Y, Z, A, B, and C axes in that order, and that they are controlled as follows:

X, Y, Z, and A axes: Controlled by the CNC

A axis: Controlled by the CNC and PMC

B and C axes: Controlled by the PMC

Then set this parameter to 4 (total 4: X, Y, Z, and A)

With this setting, the fifth and sixth axes (B and C axes) are controlled only by the PMC, and therefore cannot be controlled directly by the CNC.

NOTE

When using simplified synchronization control, specify slave axes as well as the master axis.

	#7	#6	#5	#4	#3	#2	#1	#0
1015			SVS					

[Data type] Bit

SVS When the servo along an axis is turned off, simple synchronous control is:

0 : Released.

1 : Not released.

8311	Axis number of master axis in synchronous control
------	---

[Data type] Byte axis

[Valid data range] 0 to 7

Select a master axis for simple synchronous control. Set a master axis number for the axis used as a slave axis. If the value of this parameter is 0, the first axis is the master axis. In this case, when the synchronous control select signal G138 is set to 1, operation starts with the 1st axis being the master axis.

Units digit in the parameter for the first axis

→ Set the axis number for the master axis when the first axis is used as a slave axis.

Tens digit in the parameter for the first axis

→ Set the axis number for the master axis when the second axis is used as a slave axis.

Units digit in the parameter for the second axis

→ Set the axis number for the master axis when the third axis is used as a slave axis.

Tens digit in the parameter for the second axis

→ Set the axis number for the master axis when the fourth axis is used as a slave axis.

Units digit in the parameter for the third axis

→ Set the axis number for the master axis when the fifth axis is used as a slave axis.

Tens digit in the parameter for the third axis

→ Set the axis number for the master axis when the sixth axis is used as a slave axis.

Units digit in the parameter for the fourth axis

→ Set the axis number for the master axis when the seventh axis is used as a slave axis.

Tens digit in the parameter for the fourth axis

→ Set the axis number for the master axis when the eighth axis is used as a slave axis.

Number	Tens digit	Units digit
First	Second axis	First axis
Second	Fourth axis	Third axis
Third	Sixth axis	Fifth axis
Fourth	Eighth axis	Seventh axis

NOTE

The axis number settings are: 0 for the first axis, 1 for the second axis, 2 for the third axis, and so on.

Example) To set the 3rd axis as the master axis and the 4th axis to the slave axis, set as follows:

No. 8311
 1st axis 00
 2nd axis 20
 3rd axis 00
 4th axis 00

8312

Enabling/disabling mirror image in synchronous control

[Data type] Byte axis

[Valid data range] -127 to +128

This parameter sets the mirror image function. When 100 or a greater value is set with this parameter, the mirror image function is applied to synchronous control. Set this parameter to the slave axis.

Example: To establish reversed synchronization when using the third axis as the master axis and the fourth axis as the slave axis, set parameter No. 8312 as follows:

- Parameter No. 8312 (first axis) = 0
- Parameter No. 8312 (second axis) = 0
- Parameter No. 8312 (third axis) = 0
- Parameter No. 8312 (fourth axis) = 100

M series

1010	Number of CNC-controlled axes
------	-------------------------------

NOTE
When this parameter is set, the power must be turned off before operation is continued.

[Data type] Byte

[Valid data range] 1, 2, 3, ..., the number of controlled axes

Set the maximum number of axes that can be controlled by the CNC.

[Example]

Suppose that the first axis is the X axis, and the second and subsequent axes are the Y, Z, A, B, and C axes in that order, and that they are controlled as follows:

X, Y, Z, and A axes: Controlled by the CNC

A axis: Controlled by the CNC and PMC

B and C axes: Controlled by the PMC

Then set this parameter to 4 (total 4: X, Y, Z, and A)

With this setting, the fifth and sixth axes (B and C axes) are controlled only by the PMC, and therefore cannot be controlled directly by the CNC.

NOTE
When using simplified synchronization control, specify slave axes as well as the master axis.

	#7	#6	#5	#4	#3	#2	#1	#0
3105	SMF							

[Data type] Bit

SMF During simple synchronous control, movement along a slave axis is:

0 : Included in the actual speed display

1 : Not included in the actual speed display

NOTE
This parameter is valid when simple synchronous control is applied according to the setting of parameter No. 8311 (master and slave axes can be arbitrarily selected).

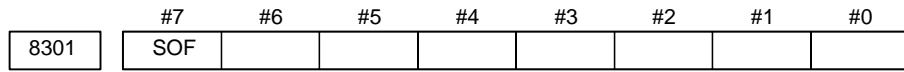

[Data type] Bit

SOF The synchronization compensation function under simple synchronous control (one master/slave axis pair) is:

- 0 : Not used.
- 1 : Used.

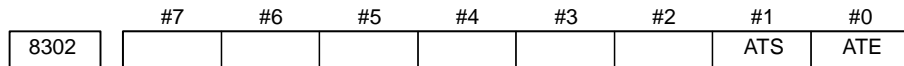

NOTE

The system power must be turned off then back on in order for this parameter setting to become effective.

[Data type] Bit

ATE Specify whether to enable the automatic setting of grid positioning under simple synchronous control (one master/slave axis pair)

- 0 : Disabled
- 1 : Enabled

ATS Specify whether to start the automatic setting of grid positioning under simple synchronous control (one master/slave axis pair)

- 0 : Not started
- 1 : Started

NOTE

- 1 Setting this parameter resets parameter APZx (bit 4 of parameter No. 1815) for the master and slave axes and parameter No. 8316 to 0.
- 2 This parameter automatically becomes 0 upon the completion of grid positioning.

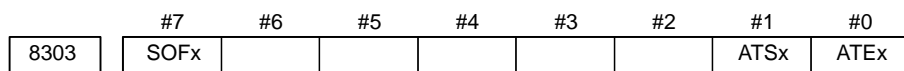

[Data type] Bit axis

ATEx Specify whether to enable the automatic setting of grid positioning under simple synchronous control (more than one master/slave axis pair)

- 0 : Disabled
- 1 : Enabled

ASTx Specify whether to start the automatic setting of grid positioning under simple synchronous control (more than one master/slave axis pair)

- 0 : Not started
- 1 : Started

NOTE

To start the automatic setting of grid positioning, set ATStx to 1. ATStx automatically becomes 0 upon the completion of automatic setting.

SOFx Specify whether to enable synchronization compensation during simple synchronous control (more than one master/slave axis pair)

0 : Disabled

1 : Enabled

8311

Axis number of master axis in synchronous control

[Data type] Byte axis

[Valid data range] 0 to 7

Select a master axis and slave axis for simple synchronous control. Set a master axis number for the slave axis side.

Example1: When using the first axis (X-axis) as the master axis, and the third axis (Z-axis) as the slave axis, set parameter No. 8311 as follows:

Parameter No. 8311 X (first axis) = 0

Parameter No. 8311 Y (second axis) = 0

Parameter No. 8311 Z (third axis) = 1

Parameter No. 8311 A (fourth axis) = 0

Example2: If there are three master/slave axis pairs under simple synchronous control:

To specify the:

master axis as the 1st axis, and the slave axis as the 6th axis

master axis as the 2nd axis, and the slave axis as the 5th axis

master axis as the 3rd axis, and the slave axis as the 4th axis,

set the following:

Parameter No. 8311 X(1st axis) = 0

Y(2nd axis) = 0

Z(3rd axis) = 0

(4th axis) = 3

(5th axis) = 2

(6th axis) = 1

NOTE

Specifying the third axis (Z-axis) as the master axis, and the first axis (X-axis) as the slave axis is not allowed. The master axis number must always be smaller than the slave axis number.

It is impossible to specify more than one slave axis for a master axis.

8313	Limit of the difference between the amount of positioning deviation of the master and slave axes (one master/slave axis pair under synchronous control)
------	---

[Data type] Word

[Unit of data] Detection unit

[Valid data range] 0 to 32767

This parameter specifies a limit imposed on the positional deviation difference between the master and slave axes. If the limit is exceeded, a P/S alarm (No. 213) is issued.

8314	Allowable error in synchronization error check
------	--

[Data type] Word axis

[Unit of data]	Increment system	IS-A	IS-B	IS-C	Unit
	Metric machine	0.01	0.001	0.0001	mm
	Inch machine	0.001	0.0001	0.00001	inch
	Rotation axis	0.01	0.001	0.0001	deg

[Valid data range] 0 to 32767

This parameter sets, in the detection unit, the allowable error when a synchronization error check is made. The mechanical coordinates of the master axis and slave axis are monitored. When a synchronization error equal to or greater than the value set in this parameter is detected, servo alarm No. 407 is issued, and the machine is stopped. Set this parameter to the master axis. When 0 is set with this parameter, no synchronization error check is performed.

8315	Maximum compensation value for synchronization compensation
------	---

[Data type] Word

[Unit of data] Detection unit

[Valid data range] 0 to 32767

This parameter sets the maximum compensation value for synchronization. When a compensation value greater than the value set in this parameter is used, servo alarm No. 410 is issued.

8316	Reference counter difference between the master and slave axes (one master/slave axis pair under synchronous control)
------	---

NOTE

The system power must be turned off then back on in order for this setting to become effective.

[Data type] Two-word

[Unit of data] Detection unit

[Valid data range] –99999999 to 99999999

This parameter is set to the reference counter difference between the master and slave axes.

NOTE

Upon the completion of grid positioning, the reference counter difference is set automatically. At the same time, parameter ATS (bit 1 of parameter 8302) is reset to 0.

8317

Torque difference alarm detection timer (one master/slave axis pair under synchronous control)

[Data type] Word

[Unit of data] ms

[Valid data range] 0 to 4000 (if 0 is specified, the system assumes 512 ms.)

This parameter specifies the time between the servo preparation completed signal SA <F000#6> becoming 1 and the torque difference alarm detection function starting to check for a torque difference alarm condition. The specified value is rounded up to the nearest multiple of 16 ms.

(Example) If 100 is specified, 112 ms is assumed.

8323

Limit imposed on the positional deviation difference between the master and slave axes (more than one master/slave axis pair under synchronous control)

[Data type] Word axis

[Unit of data] Detection unit

[Valid data range] 0 to 32767

This parameter specifies a limit imposed on the positional deviation difference between the compensation and slave axes. If the limit is exceeded, a P/S alarm (No. 213) is issued. This parameter must be set for the master axis. If 0 is specified, a positional deviation difference check is not performed.

8325

Maximum compensation to be applied during synchronization matching (more than one master/slave axis pair under synchronous control)

[Data type] Word axis

[Unit of data] Detection unit

[Valid data range] 0 to 32767

This parameter specifies the maximum compensation to be applied during synchronous compensation. If the compensation exceeds the set value, a servo alarm (No. 410) is issued. This parameter must be set for the master axis. For this setting to become effective, parameter SOFx (bit 7 of parameter No. 8303) must be set to 1.

8326

Reference counter difference between the master and slave axes (more than one master/slave axis pair under synchronous control)

[Data type] Two-word axis**[Unit of data]** Detection unit**[Valid data range]** -99999999 to 99999999

This parameter is automatically set to the reference counter difference (grid deviation) between the master and slave axes, when automatic grid position setting is performed. This parameter setting, together with an ordinary grid shift, is transferred to the servo section, when the user subsequently switches the power off then back on. This parameter must be set for the master axis.

8327

Torque difference alarm detection timer (more than one master/slave axis pair under synchronous control)

[Data type] Word axis**[Unit of data]** ms**[Valid data range]** 0 to 4000

This parameter specifies the time between the servo preparation completed signal SA <F000#6> becoming 1 and the torque difference alarm detection function starting to check for a torque difference alarm condition during simple synchronous control. The specified value is rounded up to the nearest multiple of 16 ms.

(Example) If 100 is specified, 112 ms is assumed.

This parameter must be specified for the master axis. If the set value is 0, then 512 ms is assumed.

Alarm and message

T series

Number	Message	Description
213	ILLEGAL COMMAND IN SYNCHRO-MODE	A move command was specified for the slave axis of synchronous control.
214	ILLEGAL COMMAND IN SYNCHRO-MODE	A command for coordinate system setting or shift-type tool compensation was executed during synchronous control. Correct the program.

M series

Number	Message	Description
213	ILLEGAL COMMAND IN SYNCHRO-MODE	<p>One of the following errors occurred during synchronous operation (simple synchronous control):</p> <p>(1) The program contains a move command for the slave axis.</p> <p>(2) A command for jog feed, manual handle feed, or incremental feed was issued for the slave axis.</p> <p>(3) After power on, the command for automatic reference position return was specified before a manual reference position return had been performed.</p> <p>(4) The difference in position error between the master and slave axes exceeded the value set in parameter 8313 or 8323.</p>

Servo alarm

Number	Message	Description
407	SERVO ALARM: EXCESS ERROR	<p>The following error has occurred during an operation under simplified synchronization control:</p> <p>The difference in machine coordinate value between axes in synchronization has exceeded a value specified in parameter No. 8314.</p>
410	SERVO ALARM: n AXIS EXCESS ERR	<p>The most likely causes are:</p> <ol style="list-style-type: none"> 1 For the n axis, the positional deviation observed when the axis is stopped has exceeded the value set in parameter No. 1829. 2 In simple synchronous control, the compensation used during synchronous compensation has exceeded the value set in parameter No. 8315 or 8325. This alarm occurs only for the slave axis.
420	SERVO ALARM: n AXIS SYNC TORQUE	<p>A torque command issued for the master or slave axis is greater than the value specified in parameter No. 2031. This alarm condition occurs only for the master axis.</p>

Diagnostic data

Number	Message	Description
540	SYNCHRO ERROR	The data represents the difference in position error between the master and slave axes during synchronous control. (One master/slave axis pair under synchronous control)
541	SYNCHRO ERROR	The positional difference between the master and slave axes under synchronous control is displayed. (More than one master/slave axis pair under synchronous control)

Caution

CAUTION

- 1 Set the same detection unit for both the master and slave axes.
- 2 When a manual reference position return is executed, identical movements are performed along the master and slave axes until deceleration commences. Subsequently, grids are detected separately.
- 3 Pitch error compensation and backlash compensation are executed separately for the master and slave axes.
- 4 If control of more than one master/slave axis pair is specified in parameter No. 8311, parameters to perform setting for, and display diagnostic information about, only one master/slave axis pair are invalid, and if control of only one master/slave axis pair is specified, parameters to perform setting for, and display diagnostic information about, only one master/slave axis pair are valid (except for common parameter Nos. 8311 and 8314).

Reference item

Series 16i/18i/160i/180i/ 160is/180is	OPERATOR'S MANUAL (For Machining Center) (B-63534EN)	II.20.1	Simple synchronous control
	OPERATOR'S MANUAL (For Lathe) (B-63524EN)	II.19.3	Simple synchronous control
Series 21i/210i/210is	OPERATOR'S MANUAL (For Machining Center) (B-63614EN)	II.20.1	Simple synchronous control
	OPERATOR'S MANUAL (For Lathe) (B-63604EN)	II.19.3	Simple synchronous control

1.7 TANDEM CONTROL

General

If a single motor cannot produce sufficient torque to move a large table, for example, this function allows two motors to be used. By means of this function, two motors can be used to perform movement along a single axis.

Positioning is carried out only for the master axis. The slave axis is used only to produce a torque. By means of this function, double the amount of torque can be obtained.

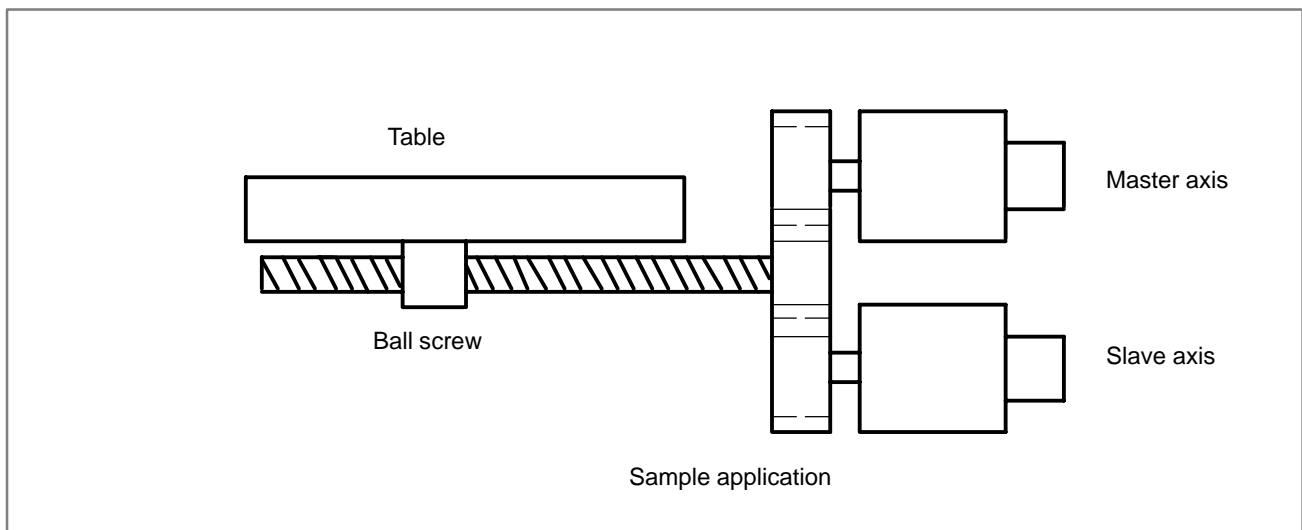

The CNC generally processes the two axes of tandem control as a single axis. In the management of servo parameters and the monitoring of servo alarms, however, the two axes are handled individually.

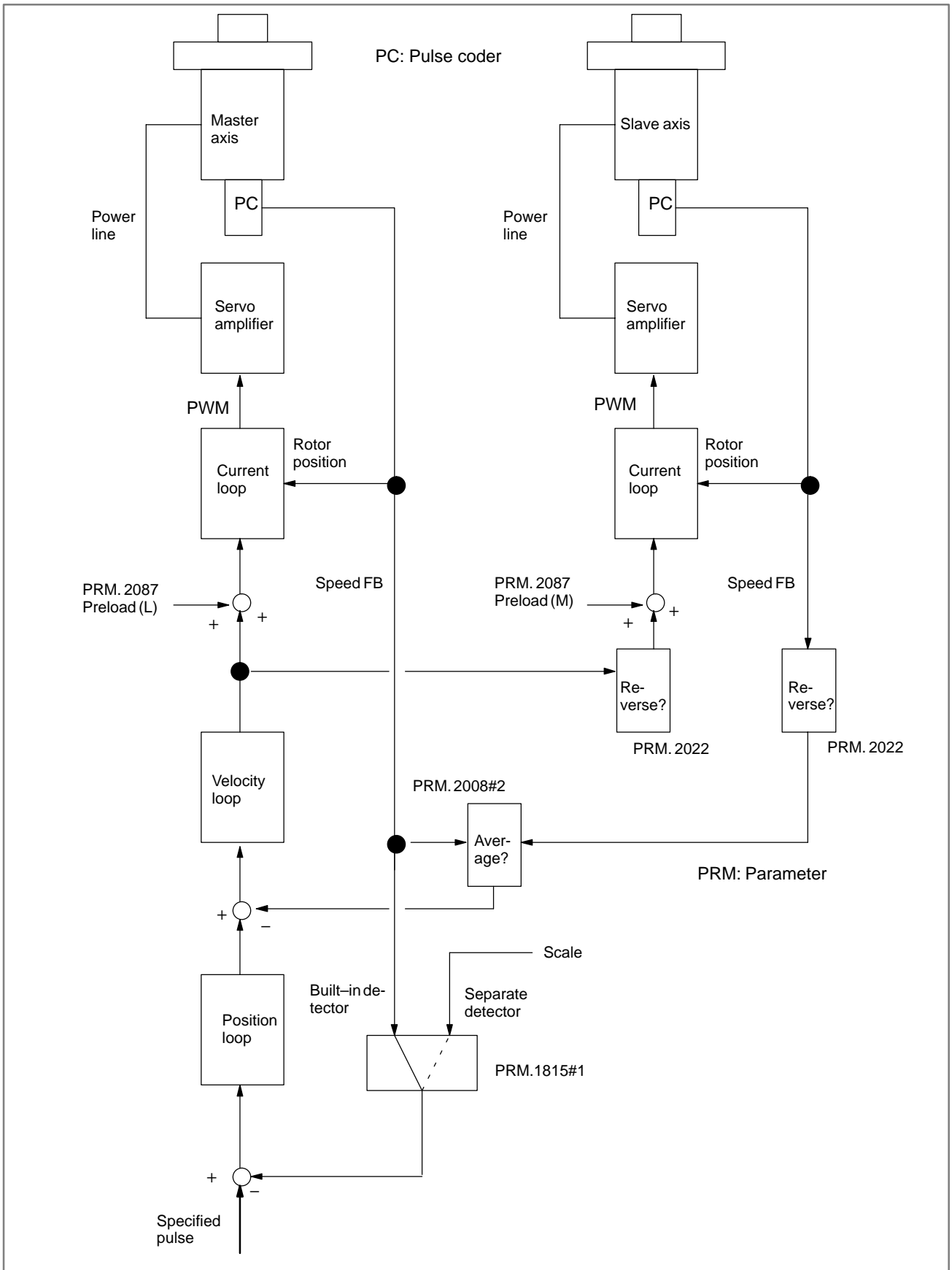

Block Diagram of Tandem Control

Explanations

● Axis configuration in tandem control

To specify the axis configuration in tandem control, follow the procedure below:

- (1) Tandem control can be performed for up to four pairs of axes.
- (2) In terms of controlled axes, the pair of axes is handled as two separate axes. In terms of CNC-controlled axes (command axes), the pair of axes is handled as a single axis (master axis). Specify the number of CNC-controlled axes with parameter 1010, excluding the slave axis of tandem control. The slave axis must be handled as if it were controlled only by the PMC.
- (3) The pair of axes is handled as two separate axes in the management of servo parameters and the monitoring of servo alarms.
- (4) Assign two consecutive numbers, that is one odd and one even number, to the master and slave axes as their servo axis numbers (parameter 1023). Assign the smaller number to the master axis.
(Example) If the servo axis number of the master axis (parameter 1023) is set to 1, specify servo axis number 2 for the corresponding slave axis. If the servo axis number of the master axis is set to 3, specify servo axis number 4 for the corresponding slave axis.
- (5) If tandem control is performed for two or more pairs of axes, assign servo axis numbers to the master and slave axes in identical order.
- (6) Specify a unique axis name for the slave axis.
- (7) The slave axis is handled as a controlled axis. Set the NDPx bit (bit 0 of parameter 3115) to 1 to suppress the position display.

The following sample axis configuration is for a machine with six axes X, Y, Z, A, B (PMC axis), and C. The X-axis and Y-axis are the master axes of tandem control.

Number of controlled axes (optional parameter): 6

Number of CNC controlled axes (parameter 1010): 3

Axis number	Axis name	Servo axis number (PRM. 1023)	
1	X	3	CNC axis (master axis of tandem control)
2	Y	1	CNC axis (master axis of tandem control)
3	Z	6	CNC axis
4	A	4	Slave axis of tandem control (master axis: X-axis)
5	B	5	PMC axis
6	C	2	Slave axis of tandem control (master axis: Y-axis)

- **Preload function**

By adding an offset to the torque controlled by the position (velocity) feedback device, the function can apply opposite torques to the master and slave axes so that equal and opposite movements are performed for both axes. This function can reduce the effect of backlash on the master and slave axes caused by the tandem connection of the two motors via a gear. This function, however, cannot reduce backlash between the ball screw and table or other backlash inherent to the machine.

If a preload of x is set for the master axis and $-x$ for the slave axis, the opposing preload torques are continuously applied to the two axes, even at rest, as shown below:

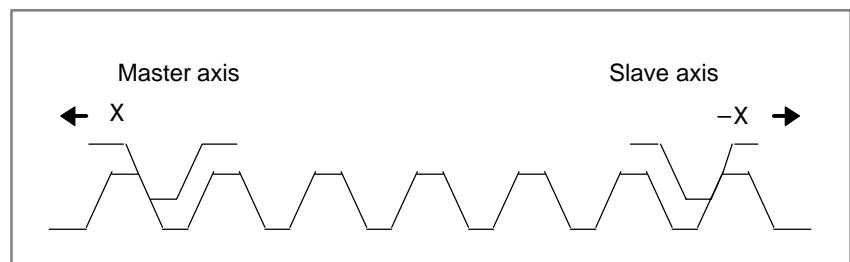

CAUTION

- 1 Specify as low a preload as possible. Avoid specifying a preload higher than the rated torque. Too high a preload will trigger an overload alarm because the specified torques continue to be applied, even at rest. A preload that is only slightly higher than the frictional force is recommended. Thus, the recommended preload may be about one-third of the rated torque.
- 2 If the motors rotate in opposite directions (different signs are specified in parameter 2022), specify the preload values with the same sign.

- **Velocity feedback average function**

As shown in the block diagram of tandem control, the motor of the slave axis is not subject to velocity control. A machine with a large amount of backlash may become unstable if the motor of the slave axis vibrates as a result of backlash in the gear. This can be overcome by applying velocity control to the slave axis also. This velocity feedback average function is enabled when bit 2 of parameter 2008 is set to 1.

- **Improved stability of a closed-loop system**

The following two functions can increase the stability and position gain of a closed-loop system having a linear scale:

- Dual position feedback function
- Machine velocity feedback function

For details of these functions, refer to FANUC AC SERVO MOTOR α series PARAMETER MANUAL (B-65150E) or FANUC AC SERVO MOTOR αi series PARAMETER MANUAL (B-65270EN).

- **Notes on stability of tandem control**

An important factor affecting stability in tandem control is the capability of back feed. Back feed is to cause movement along either the master or slave axis from the other axis, via the transmission mechanism connecting the two axes. A machine without this capability may be inclined to become unstable and require adjustments.

- **Connection of axis signals**

The DI/DO signals, generally connected to each axis, must be connected only to the master axis of two axes of tandem control. The signals need not be connected to the slave axis. The following signals, however, may have to be connected depending on the application.

- i) Controlled axis detach signal and servo off signal
Connect these signals so that the master and slave axis signals are simultaneously input.
- ii) Overtravel limit signal
Connect the signal so that 1 is always output as the overtravel limit signal for the slave axis.

If the slave axis stroke limit must also be detected, connect the signals so that the signal detected on the slave axis is sent to the overtravel limit signal of the master axis.

- **Connecting motors**

Connect the motors according to the servo axis numbers. Connect the feedback cable of the slave axis.

(Sample connection for position feedback cable)

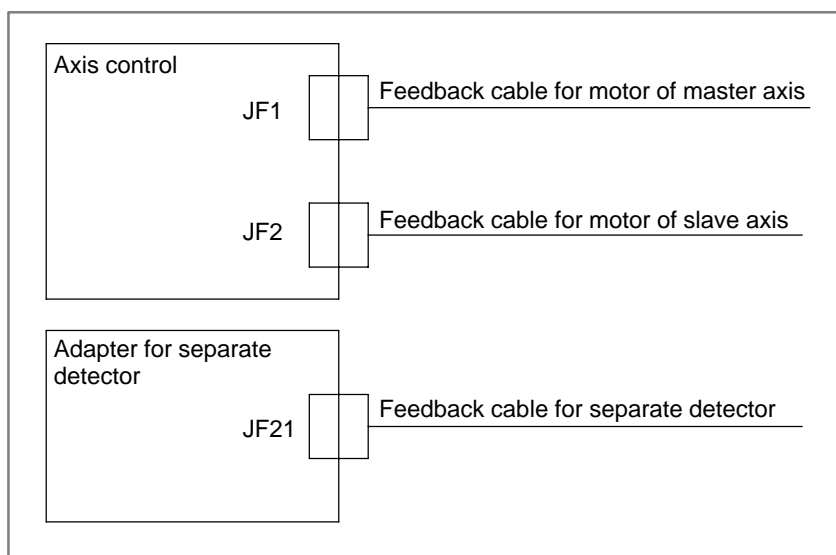

- **Servo alarms**

Motor overload and other servo alarms are displayed separately for the master and slave axes.

Parameter

Setting data (parameters)

The parameters that are generally set for each axis can, when set for axes under tandem control, be classified into the following three groups:

- i) Parameters in which identical values must be set for the master and slave axes
- ii) Parameters that must be specified only for the master axis (The corresponding parameter for the slave axis is not used.)
- iii) Parameters for which different values may be set for the master and slave axes

The classifications of the parameters are described below. Any parameter that is not listed in the tables for the three classifications should be processed as a parameter of type i) and, specify identical values for the master and slave axes.

WARNING

Note that, if different values are set for the master and slave axes in a parameter of type i), the operations for the two axes of tandem control will not be performed correctly.

- Care must be taken to specify the following two servo parameters, according to the directions of rotation around the master and slave axes.

Parameter 2022: Direction of rotation of the motor

Parameter 2087: Preload value

In parameter 2022, specify 111 for forward rotation and –111 for the reverse rotation.

In parameter 2087, specify values having identical signs when the motors of the master and slave axes rotate in opposite directions. Specify values having different signs when the motors of the master and slave axes rotate in the same direction.

- If a separate pulse coder is used, use of the separate pulse coder must be set for the master axis. For the slave axis, use of a built-in pulse coder must be set. Therefore, pay particular attention to setting the following parameters.

Bit 1 of parameter 1815: Separate pulse coder

Bits 6 to 4 of parameter 1816: Detection multiplier (DMR)

Parameter 2024: Number of position detection feedback pulses (PPLS)

Parameter 1821: Capacity of an optional reference counter

Parameter 2084: Numerator of flexible feed gear ratio

Parameter 2085: Denominator of flexible feed gear ratio

If, for example, a motor with serial pulse coder A is used with a linear scale capable of detecting a position in 1- μ m units, and if a single rotation of the motor produces a movement of 4 mm, specify the parameters as shown below:

		Master axis	Slave axis
No. 1815#1	=	1	0
No. 1816	=	01110000	01110000
No. 2024	=	4000	12500
No. 1821	=	4000	4000
No. 2084	=	0	4
No. 2085	=	0	1000

Parameters that should be set only for the master axes

Parameter No.	Meaning of parameters
0012#0	Mirror image
0012#7	Servo control off
1004#7	Input unit 10 times
1005#4	External deceleration in plus direction
1005#5	External deceleration in minus direction
1005#7	Servo control off
1022	Parallel axis specification
1220	External workpiece coordinate shift
1221	Workpiece zero point offset by G54
1222	Workpiece zero point offset by G55
1223	Workpiece zero point offset by G56
1224	Workpiece zero point offset by G57
1225	Workpiece zero point offset by G58
1226	Workpiece zero point offset by G59
1423	Jog feedrate
1424	Manual rapid traverse
1425	FL rate in manual reference position return
1427	External deceleration rate at rapid traverse
1430	Maximum feedrate
1815#1	Separate type pulse coder
1815#5	Absolute pulse coder
2008#2	Velocity feedback average function

Parameters that may be set to different values for the master and slave axes

Parameter No.	Meaning of parameters
1020	Axis name
1023	Servo axis number
2022	Motor rotation direction
2087	Preload value
3115	Current position display
1310#0	Soft OT2
1310#1	Soft OT3
1320	1st stroke limit of plus side
1321	1st stroke limit of minus side
1322	2nd stroke limit of plus side
1323	2nd stroke limit of minus side
1815#1	Separate type pulse coder
1816#6 to #4	Detection multiplier (DMR)
1821	Arbitrary reference counter capacity
2024	Position detection feedback pulses (PPLS)
2084	Numerator of flexible feed gear ratio
2085	Denominator of flexible feed gear ratio

Parameters that should be set to the same values for the master and slave axes

Parameter No.	Meaning of parameters
1005#0	Movement before reference position return
1005#1	Dogless reference position setting
1006#0	Rotary axis
1006#1	Machine coordinate of rotary axis is rotary type
1006#3	Diameter/radius specification
1006#5	Direction of reference position return
1006#7	Least input increment (0.0001 mm)
1240	Reference position as viewed from machine zero
1241	Coordinate of 2nd reference position
1242	Coordinate of 3rd reference position
1243	Coordinate of 4th reference position
1260	Move distance per rotation of rotary axis
1420	Rapid traverse rate
1421	F0 of rapid traverse override
1620	Time constant of rapid traverse linear acceleration/deceleration
1621	Time constant of rapid traverse bell shaped acceleration/deceleration
1622	Time constant of feed exponential acceleration/deceleration
1623	FL of feed exponential acceleration/deceleration
1624	Time constant of manual continuous exponential acceleration/deceleration
1625	FL of manual continuous exponential acceleration/deceleration
1626	Time constant of exponential acceleration/deceleration during thread cutting cycle
1627	FL of exponential acceleration/deceleration during thread cutting cycle
1820	Command multiplier (CMR)
18XX	Digital servo parameters
20XX	Digital servo parameters

	#7	#6	#5	#4	#3	#2	#1	#0
1817		TAN						

[Data type] Bit axis (set to each axis)
Set for both master and slave axes.

TAN Tandem control is
0 : ignored
1 : valid

	#7	#6	#5	#4	#3	#2	#1	#0
2008						VFBAVE		

[Data type] Bit axis (set to each axis)
Set only for the master axes.

VFBAVE Velocity feedback average function
0 : invalid
1 : valid

2087	Preload of each axis (Tcmd offset)
------	------------------------------------

[Data type] Word axis

[Unit of data] (Preamplifier limit) /7282

[Valid data range] -1821 to 1821

An offset is added to a torque command to reduce backlash.
Set a slightly large value than that of the friction torque of the motor.
As a reference set a value one-third the rated torque.

[Example] To set a torque of 3A in the opposing directions for the master and slave amplifiers that have current limit of 40A:

$$3 / (40 / 7282) = 546$$

$$\text{Master side} = 546$$

$$\text{Slave side} = -546$$

2021	Load inertia
------	--------------

[Data type] Word axis

Set the same value to the master and slave axes.

[Unit of data] $\frac{(\text{All load inertia})}{2} / (\text{Motor inertia}) \times 256$

2022	Direction of rotation of motor
------	--------------------------------

[Data type] Word axis

Set the direction of motor rotation.

If the rotation directions of master and slave axes are opposite, set them by this parameter.

Alarm and message

Number	Message	Description
417	SERVO ALARM: n AXIS DGTL PARAM	Illegal values are set for parameter 1010, 1023, or 1817 when tandem control is performed.

Reference item

Series 16i/18i/160i/180i/ 160is/180is	OPERATOR'S MANUAL (For Machining Center) (B-63534EN)	II.20.4	Tandem control
---	--	---------	----------------

1.8 SYNCHRONOUS CONTROL (T SERIES)

General

This function enables synchronous control, in which an axis can be synchronized with another axis.

An axis can be moved in synchronization with another axis. This is done by issuing a move command for one axis (synchronous master axis) to another axis so that both axes behave in the same way. When this function is used in conjunction with the parking function, which keeps an axis at rest by ignoring a move command for it, the following operations can be performed.

- (1) Two axes move in synchronization. (Both master and slave axes move.)
- (2) One axis moves according to a move command originally issued to another axis which remains stopped. (The master parks, but the slave moves.)
- (3) The coordinate values for one axis are updated according to the amount of movement specified for another axis, but remains stopped. (The master moves, but the slave parks.)

CAUTION

- 1 The term synchronous control used here only refers to an operation in which the same move command is issued to two different servo systems at one time. Note that synchronous control does not involve out-of-synchronization compensation, in which the deviation between two servo motors is constantly checked and one of the servo motors is subjected to compensation to reduce the deviation.
- 2 The term parking means to issue no move command to a servo system. No coordinate values are updated during parking. However appropriate parameter setting can change absolute and relative coordinate systems.
- 3 If synchronous control is terminated during automatic operation, a move command or coordinate system setting may not be specified for the synchronous slave axis in the current block and two blocks that follows it (or three blocks for tool-nose radius compensation).

Automatic setting of workpiece coordinate system

• Explanation

When synchronous control is started for a workpiece coordinate system, it is possible to specify the workpiece coordinate system automatically. When synchronous control for a workpiece coordinate system is terminated, it is possible to return the workpiece coordinate system to ordinary machining (not synchronous control). The explanation of the workpiece coordinate system used during synchronous control follows: For example, when synchronous control is used to move an axis differently from the way originally specified, the master axis may be placed in a parking state, while the slave axis is allowed to move. In such a case, it will be convenient if a coordinate system used to represent the current position of the slave axis is used as a workpiece coordinate system for the master axis. Conventionally, this workpiece coordinate system must be specified by program when synchronous control is started, because the workpiece coordinate system does not originally belong to the master axis. This automatic workpiece coordinate system setting function for synchronous control sets up this workpiece coordinate system automatically. This function can also resume the original workpiece coordinate system for the master axis automatically. This function does not work for the slave axis.

• Setting and command

In addition to setting ordinary synchronous control, parameters must be specified as follows:

- (1) To set up a workpiece coordinate system for synchronous control automatically when starting synchronous control
 - Set parameter No. 8163 (SPMx) to "1". (Master axis parameter only)
 - Set parameter No. 8185 with the coordinates of the master axis when both master and slave axes are at the reference position.
- (2) To resume the ordinary workpiece coordinate system automatically when synchronous control is terminated
 - Set parameter No. 8163 (SPSx) to "1". (Master axis parameter only)
 - Set parameter No. 1250 with the workpiece coordinates of the master axis when the master axis is at the reference position.

This synchronous control can be specified using the G0138 signal similarly to the ordinary synchronous control. When the signal is raised to start synchronous control, the workpiece coordinate system for the master axis is automatically set up. Likewise, when the signal is dropped to terminate synchronous control, the original workpiece coordinate system for the master axis is set automatically.

• Workpiece coordinate value calculation method

(1) Workpiece coordinate system for synchronous control

$$\begin{aligned}
 & \text{(Master axis workpiece coordinate value)} \\
 & = \text{(parameter No. 8185 for the master axis)} \\
 & \pm \text{(slave axis machine coordinate value)} \quad \boxed{1} \\
 & + \text{(master axis machine coordinate value)} \quad \boxed{2}
 \end{aligned}$$

$\boxed{1}$ + :Master axis parameter SCDx = 0

- :Master axis parameter SCDx = 1

$\boxed{2}$ Master axis parameter SCMx = 1 only

(2) Workpiece coordinate system for ordinary operation

$$\begin{aligned} & \text{(Master axis workpiece coordinate value)} \\ & = \text{(parameter No. 1250 for the master axis)} \\ & + \text{(master axis machine coordinate value)} \end{aligned}$$

- Others

- If many slave axes are synchronized with one master axis, the master axis is set with the workpiece coordinate system that corresponds to the current position of the first slave axis that is synchronized with the master axis.
- The same least command and input increments must be applied to both master and slave axes.
- The tool offset is taken into consideration when the coordinate system is set up. So, the coordinate system is set up normally even when tool geometry compensation is applied.
- If synchronous control that involves automatic coordinate system setting is started or terminated during automatic operation, a move command or other commands that reference the current position of an axis may not be specified in the current block and two blocks that follow it (or three blocks for tool-nose radius compensation). An exception is an M code in which the current block is not buffered. For the M code, a move command can be executed in the block next to the block that involves synchronous control.

Signal

Synchronous control axis selection signals SYNC1 to SYNC8 <G138>

[Classification] Input signal

[Function] These signals perform synchronous control.

[Operation] When one of these signals becomes “1”, the control unit:

- Starts synchronous control with the axis corresponding to this signal used as the slave axis.

The axis with which the slave axis is synchronized is determined by parameter No. 8180.

Parking signals PK1 to PK8 <G122>

[Classification] Input signal

[Function] These signals place each axis in a parking state.

[Operation] When one of these signals becomes “1”, the control unit:

- Places the corresponding axis in a parking state.

If the corresponding axis is under synchronous control, it enters a parking state immediately regardless of whether the axis is moving. If a parking signal is set to “1” without specifying synchronous control, it is ignored.

Synchronous control under way signals SYN10 to SYN80 <F118>

[Classification] Output signal

[Function] These signals indicate each axis is being subjected to synchronous control.

[Operation] These signals become “1” under the following condition:

- The corresponding axis is under synchronous control.

These signals become “0” under the following condition:

- The corresponding axis is not under synchronous control.

CAUTION

Whether each axis is under synchronous control does not always match whether the corresponding selection signal (synchronous control axis selection signal) has been issued or not. For example, if these signals are set to “1” during an alarm, they are ignored. If a servo alarm occurs during synchronous control, it is terminated automatically. Before attempting to perform synchronous control, always check the state of these signals.

Signal address

	#7	#6	#5	#4	#3	#2	#1	#0
G0138	SYNC8	SYNC7	SYNC6	SYNC5	SYNC4	SYNC3	SYNC2	SYNC1
G0122	PK8	PK7	PK6	PK5	PK4	PK3	PK2	PK1
	#7	#6	#5	#4	#3	#2	#1	#0
F0118	SYN80	SYN70	SYN60	SYN50	SYN40	SYN30	SYN20	SYN10

Parameter

	#7	#6	#5	#4	#3	#2	#1	#0
8160	NRS							

[Data type] Bit

NRS When the system is reset, synchronous, composite, or superimposed control is:

0 : Released.

1 : Not released.

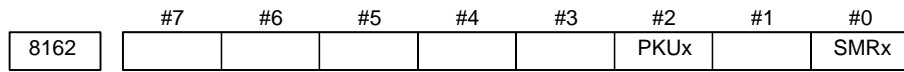

[Data type] Bit axis

SMRx Synchronous mirror-image control is:

- 0 : Not applied. (The master and slave axes move in the same direction.)
- 1 : Applied. (The master and slave axes move in opposite directions.)

PKUx In the parking state,

- 0 : The absolute, relative, and machine coordinates are not updated.
- 1 : The absolute and relative coordinates are updated. The machine coordinates are not updated.

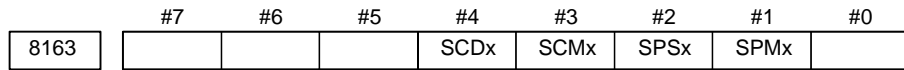

[Data type] Bit axis

Set the parameters SPMx, SPSx, SCMx, and SCDx for the master axis.

SPMx When synchronous control is started, automatic workpiece coordinate system setting for the master axis is

- 0 : Not performed.
- 1 : Performed.

NOTE

When a workpiece coordinate system is automatically set at the start of synchronous control, the workpiece coordinate system is calculated from the current machine coordinates and the workpiece coordinates of each axis at the reference position are set in parameter No. 8185.

SPSx When synchronous control terminates, automatic workpiece coordinate system setting for the master axis is:

- 0 : Not performed.
- 1 : Performed.

NOTE

When a workpiece coordinate system is automatically set at the end of synchronous control, the workpiece coordinate system is calculated from the current machine coordinates and the workpiece coordinates for each axis at the reference position are set in parameter No. 1250.

SCMx When workpiece coordinates are calculated in synchronous control:

- 0 : The workpiece coordinates are calculated from the machine coordinates of the slave axis.
- 1 : The workpiece coordinates are calculated from the machine coordinates of the master axis and slave axis.

SCDx The positive (+) directions of the master axis and slave axis in the coordinate system in synchronous control are:

0 : Identical.

1 : Opposite.

The value set in this parameter is referenced when the workpiece coordinates of the master axis are set up automatically at the beginning of synchronous control.

8180

Master axis with which an axis is synchronized under synchronous control

[Data type] Byte axis

[Valid data range] 201, 202, 203, ... to 200 plus the maximum number of control axes

This parameter specifies the number of the master axis with which an axis is synchronized. When zero is specified, the axis does not become a slave axis and is not synchronized with another axis. When an identical number is specified in two or more axes, one master axis has two or more slave axes.

In the parameter of a slave axis, specify 200 plus the number of the master axis with which the slave axis is to be synchronized.

Setting: 201 to 208

The value specified here must not exceed 200 plus the maximum number of control axes.

8185

Workpiece coordinates on each axis at the reference position

[Data type] Two-word axis

[Unit of data]	Increment system	IS-A	IS-B	IS-C	Unit
	Millimeter machine	0.01	0.001	0.0001	mm
	Inch machine	0.001	0.0001	0.00001	inch
	Rotation axis	0.01	0.001	0.0001	deg

[Valid data range] -99999999 to 99999999

This parameter sets the workpiece coordinates on each master axis, subject to synchronous control, when the master and slave axes are at the reference position. This parameter is enabled when SPMx of bit 1 parameter No. 8163 is set to 1. Set this parameter for the master axis.

Alarm and message

Number	Message	Description
225	Axis recomposition error	This alarm occurs under either of the following conditions. (It is detected when synchronous control is specified.) (1) There is an error in axis number parameter setting. (2) There is an error in a control command.
226	A move command was issued to a synchronous axis.	A move command was issued to an axis to be synchronized with another axis.

Warning, Caution, and Note for synchronous control**WARNING**

- 1 When synchronous control is started or terminated, the target axes must be at a stop.
- 2 All axes subjected to synchronous control must have the same least command increment, detection unit, and diameter/radius specification. Otherwise, the amount of movement will differ from one axis to another.
- 3 During synchronous control, do not change the parameters related to synchronous control.
- 4 Before starting synchronous control after an emergency stop, servo-off, or servo alarm is released, be sure to make a return to the reference position and set up the necessary coordinate system.
- 5 Before starting synchronous control, make sure that for the target axes, a reference position return after power-on has been made and a reference position has been set up according to the absolute pulse coder.
- 6 Acceleration/deceleration control, pitch error compensation, backlash compensation, and stored stroke limit check are performed independently of synchronization control.
- 7 A move command should not be issued to a synchronous slave axis during synchronous control.
- 8 The same acceleration/deceleration time constants and servo parameters should be used for the axes subjected to synchronous control as much as possible.
- 9 The workpiece coordinate system of a synchronous slave is not affected by the synchronous master axis operations that affect the workpiece coordinate system but do not cause the machines to move, such as workpiece coordinate system set/shift and geometry offset commands.
- 10 If a wear offset command or tool-tip radius compensation is performed for a synchronous master axis, the travel path of the slave axis is shifted by the offset, but the offset is not set (no offset vector is created).
- 11 When using parking signal PK7 or PK8 while both spindle synchronous control and simple spindle synchronous control are being applied, set the SPK bit (bit 7 of parameter No. 4800) to 1. This sets parking signals PKESS1 and PKESS2, used for simple spindle synchronous control, to #6 and #7 of G031.

NOTE

- 1 More than one axis can be placed in a synchronous state at the same time. However, an axis cannot be synchronized with more than one axis simultaneously.
- 2 Synchronous control and simplified synchronous control cannot be specified simultaneously.

Restrictions imposed during synchronous control

Function	During synchronous control
Acceleration/deceleration control	The same type of acceleration/deceleration control is performed for the synchronous axes, but different time constants are used.
Feedrate clamping	The axes are clamped at the feedrate of the master axis.
Reference position return	A reference position return is possible for the master axis unless it is in a parking state. In a parking state, only automatic reference position return (G28) is possible for the master axis (*1).
Reference position return check	Possible (*2)
PMC axis control	Possible for other than synchronous slave axes.
Polar coordinate interpolation and cylindrical interpolation	Possible
Handle interrupt	Performed regardless of synchronous control
Axial mirror image	Each signal originally belonging to a particular axis is effective for that axis.
Machine lock	Each signal originally belonging to a particular axis is effective for that axis.
Interlock	The signals for the master axis are effective for the slave axes.
Override	The signals for the master axis are effective for the slave axes.
External deceleration	The signals for the master axis are effective for the slave axes.
Skip function	Ineffective for slave axes.
Automatic tool compensation	Ineffective for slave axes.
Tool setter	Ineffective for slave axes.
Follow-up	Impossible during synchronous control.
Program restart	Impossible for a program involving synchronous control.
Spindle positioning	Synchronous control is impossible.

WARNING

If a reference position return command is issued for a synchronous master axis during synchronous control, it is executed normally for the master axis, but the slave axis does not return to their reference position (the slave axis only moves in synchronization with the reference position return of the master axis) except for an automatic reference position return (G28) issued when the master axis is in a parking state, in which case the amount of movement is calculated so that the slave axis returns to its reference position provided that a reference position return has been carried out for the slave axis. If more than one slave axis belongs to one master axis, a reference position return command is executed so that the lowest-numbered slave axis returns to its reference position. A return to the second (third or fourth) reference position by the G30 command works in the same way as G28.

CAUTION

If a reference position return check (G27) is specified during synchronous control, the master and slave axes move to the specified position. Upon completion of axis movement, a check is made to see whether the master axis is at its reference position (no check is made for the slave axes) unless the master axis is in a parking state, in which case a check is made to see whether the lowest-numbered slave axis is at its reference position after completion of positioning.

Reading the coordinate values during synchronous control

The following list summarizes how positional information such as custom macro system variables and current coordinates from the PMC window are read during synchronous control.

Positional information	During synchronous control
Absolute coordinate	Readable
Machine coordinate	Readable
End of each block	Readable only for the master axis
Skip signal position	Readable only for the master axis

**Terminating
synchronous control**

Synchronous control is terminated not only when the corresponding synchronization signal becomes off but also when one of the following conditions occurs.

- (1) Emergency stop
- (2) Reset
- (3) Servo alarm
- (4) Servo off
- (5) Overtravel
- (6) Alarm related to synchronous control
- (7) P/S000 alarm

The above conditions terminate synchronous control for all axes.

Reference item

Series 16i/18i/160i/180i/ 160is/180is	OPERATOR'S MANUAL (For Lathe) (B-63524EN)	II.19.4	Synchronous control
---	--	---------	---------------------

1.9 SYNCHRONOUS CONTROL AND COMPOSITE CONTROL (T SERIES (TWO-PATH CONTROL))

1.9.1 Overview

The T series CNC has two independent control paths. For example, it can be used to control two turrets of a multiple-turret lathe independently. The axes (such as X1- and Z1-axes) belonging to path 1 are controlled by commands in path 1, and the axes (such as X2- and Z2-axes) belonging to path 2 are controlled by commands in path 2.

- Independent control in each path

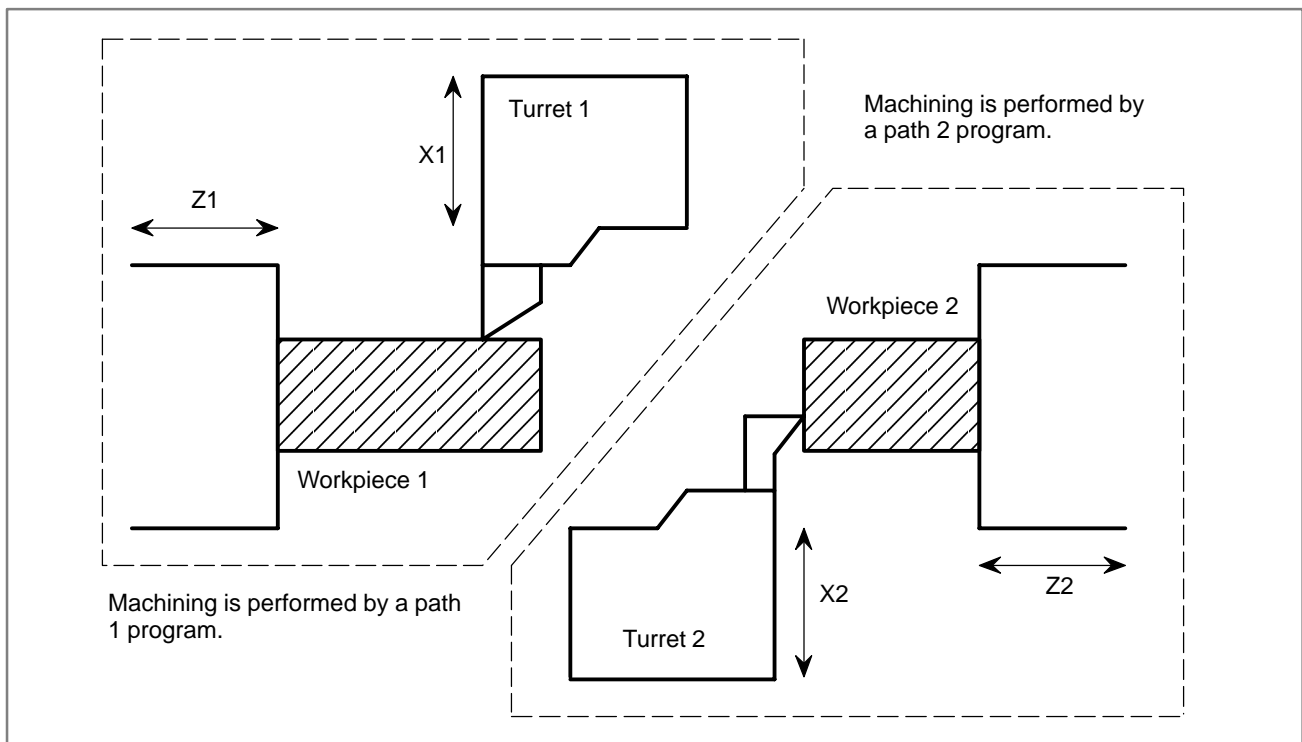

This function enables synchronous control between paths or within a path, composite control between paths, and superimposed control between paths, as explained below.

(1) Synchronous control

- Synchronization of an axis in one path with an axis in the other path

(Example) Synchronization of the Z1-axis with the Z2-axis

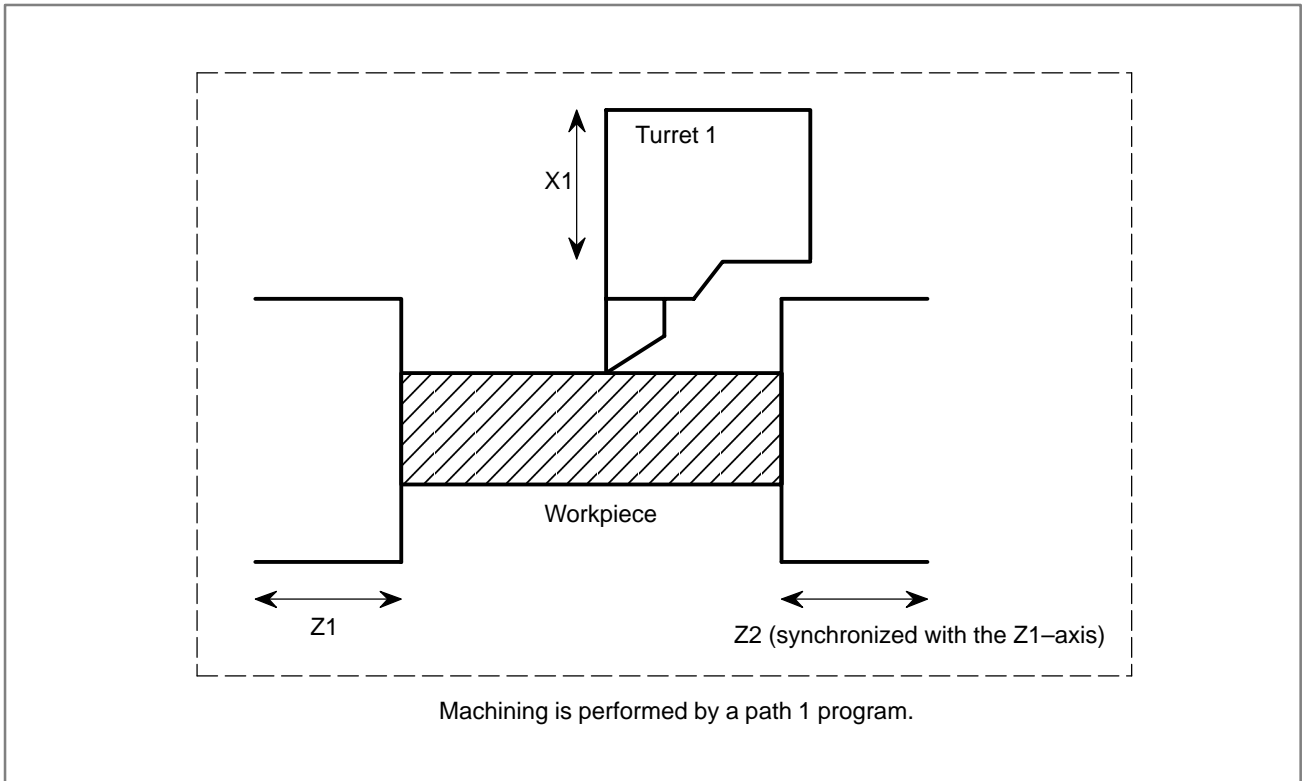

- Synchronization of an axis in one path with another axis in the same path

(Example) Synchronization of the Z1-axis with the B1-axis

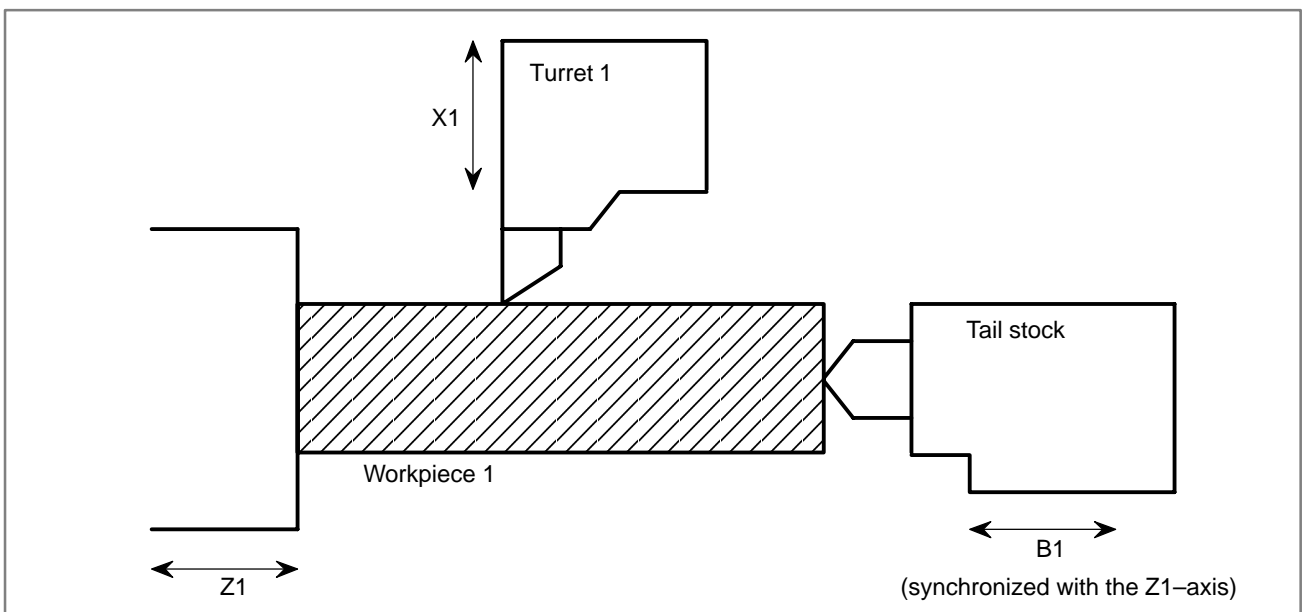

(2) Composite control

- Interchanging move commands for an axis in one path with those for an axis in the other path.

(Example) Interchanging commands between the X1- and X2-axes

- Control both X2- and Z1-axes by commands in a path 1 program
- Control both X1- and Z2-axes by commands in a path 2 program

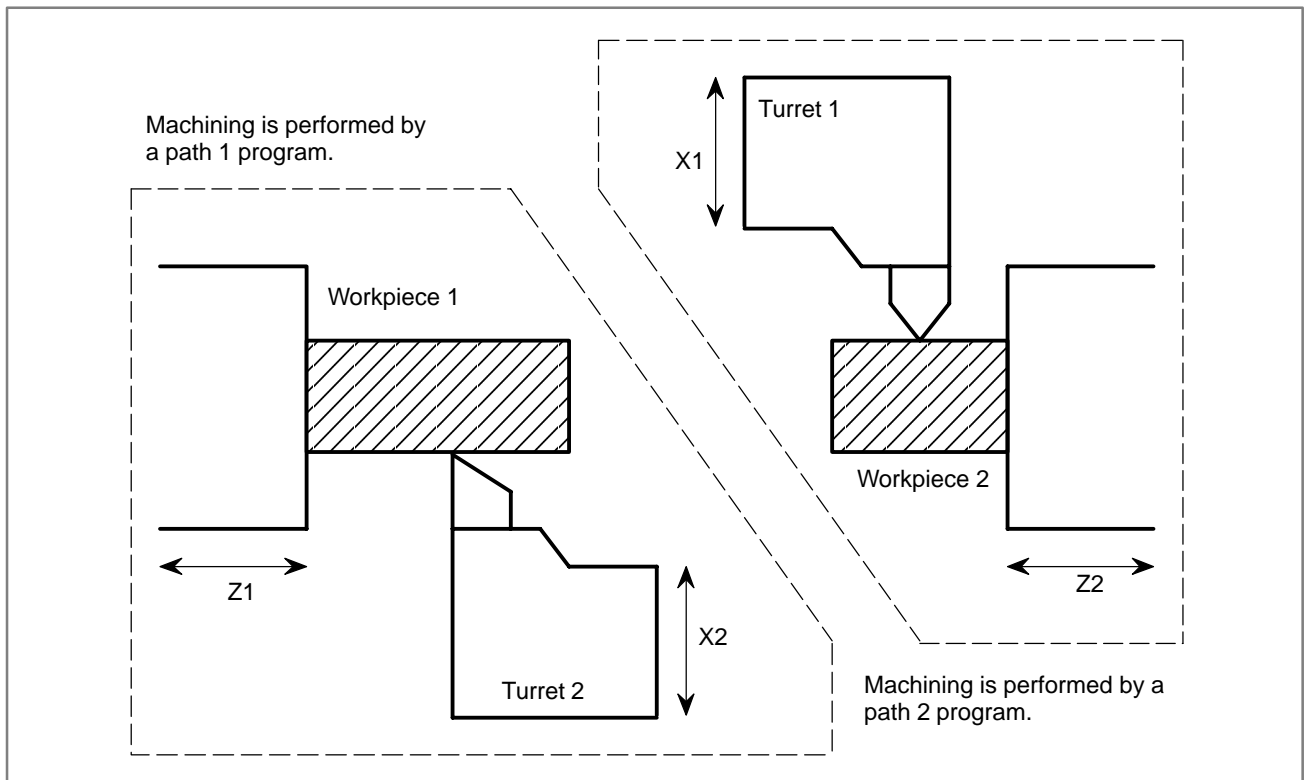

(3) Superimposed control

- Superimposing move commands for an axis in one path on an axis in the other path

(Example) Superimposing the movement of the Z1-axis on the Z2-axis

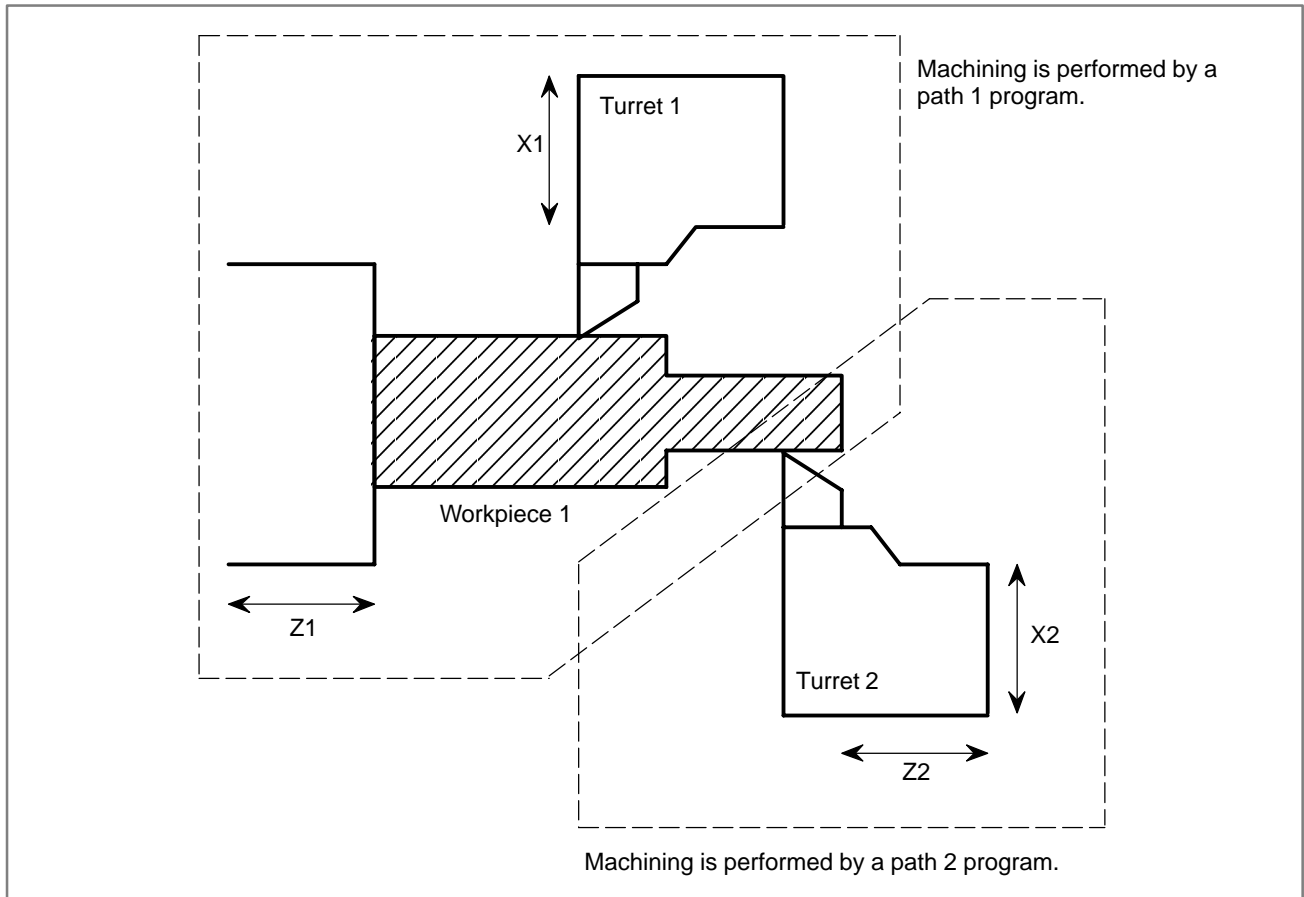

1.9.2 Synchronous Control

An axis in one path can be synchronized with another axis in the same path or an axis in another path. This is done by issuing the same move commands for one axis (synchronous master axis) to another axis (synchronous slave axis). Using parameter SMRx (bit 0 of parameter No. 8162) can cause the slave axis to move in the direction opposite to that of the master axis. It is possible to place either the master or slave axis in a parking state. The term parking here means to discontinue giving move commands to a servo system. No coordinates are updated in the parking state. Note however that absolute and relative coordinates can be updated using parameter PKUx (bit 2 of parameter No. 8162).

Setting

Parameter No. 8180 specifies which axis is to be synchronized with which axis.

(Example)

To synchronize the Z1-axis with the Z2-axis:

Parameter No. 8180z of path 1 = 2

To synchronize the Y2-axis with the X1-axis:

Parameter No. 8180y of path 2 = 1

To synchronize the Y1-axis with the X1-axis:

Parameter No. 8180y of path 1 = 201

Programming

Use M codes for wait, beginning, and terminating synchronization in a machining program in the stated order. It is also possible to begin and terminate synchronous control without using M codes.

Signal operation

When synchronization begins or ends (when an M code is issued, for example), the synchronous control axis selection signals SYNC1 to SYNC7 for the slave axis (from the PMC to the CNC) are changed from “0” to “1” (to begin synchronization) or from “1” to “0” (to terminate synchronization). To place an axis in a parking state, a parking signal PK1 to PK7 is set to “1” for the target axis.

Examples of applications

The following operations can be performed by using the synchronization functions together with the parking function, which causes move commands for an axis to be ignored and keeps the axis at a rest.

(1) Moving an axis in one path in synchronization with an axis in the other path (Both master and slave axes move.)

(Example 1) Synchronizing the Z2-axis with the Z1-axis
(machining with both ends of a workpiece chucked)

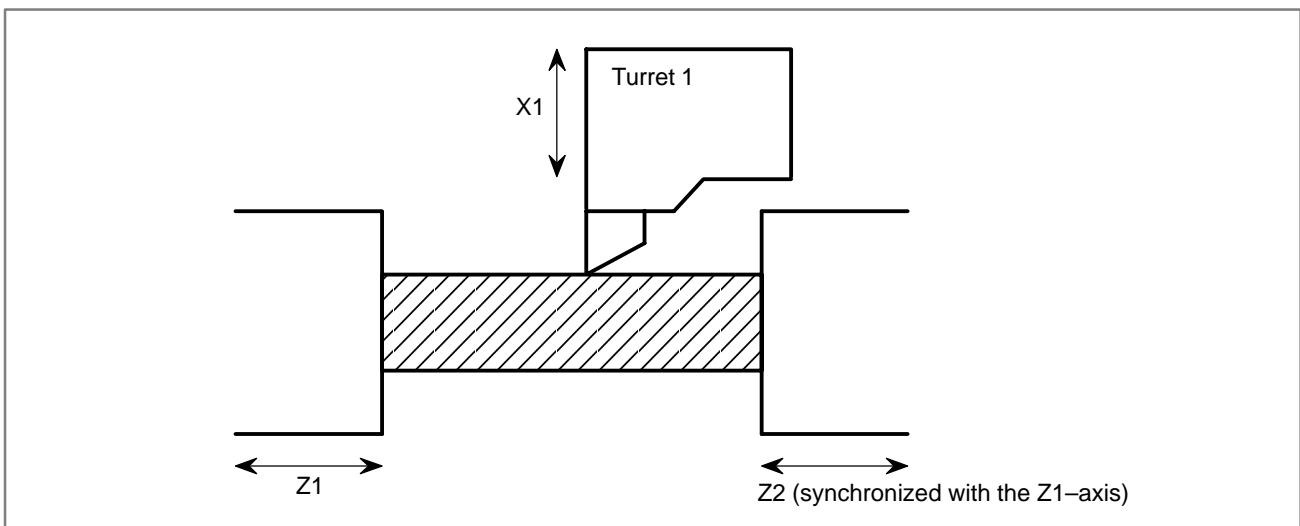

(Example 2) Synchronizing the X2- and Z2-axes with the X1- and Z1-axes (balanced cutting)

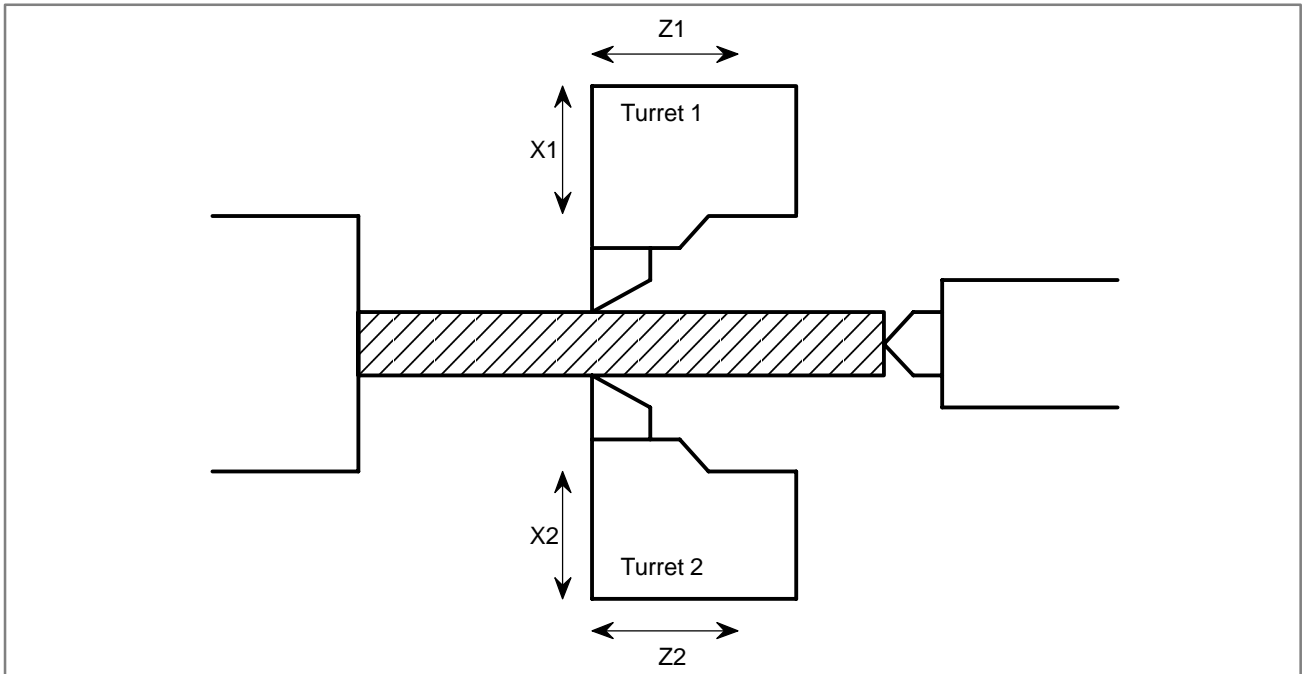

(Example 3) Synchronizing the B1-axis (tail stock axis) with the Z1-axis

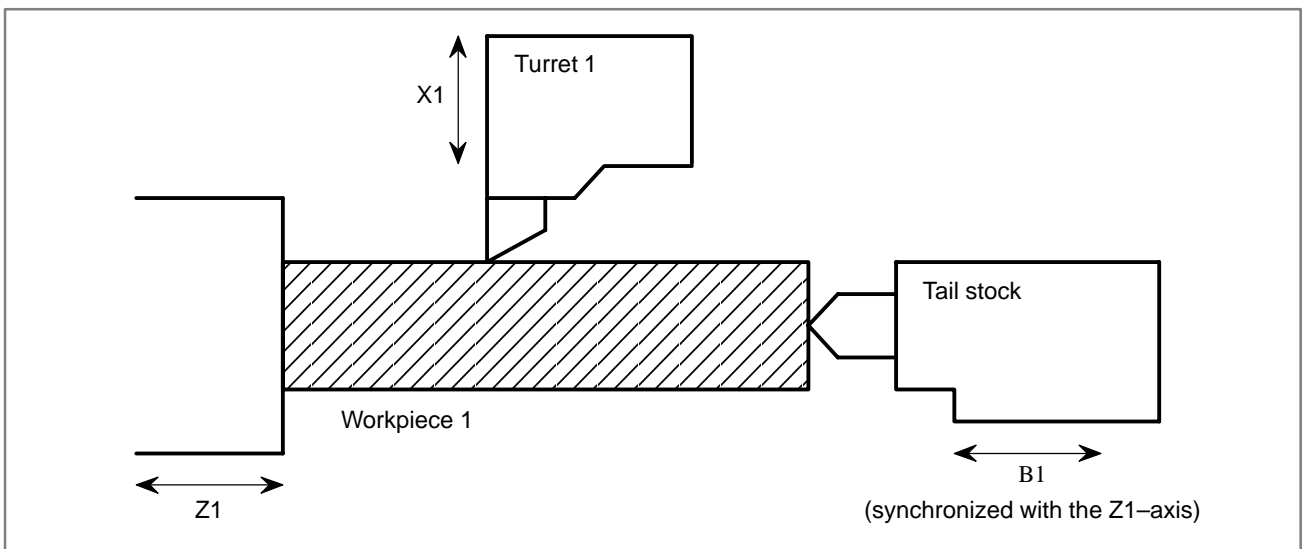

(2) Moving an axis in one path using move commands for an axis in the other path (The master axis parks and the slave axis moves.)

(3) Updating the coordinates of an axis in one path by the amount of movement for an axis in the other path (The master axis moves and the slave axis parks.)

Using method (2) or (3) can control one motor from both paths.

(Example 4) Sharing one motor with the Z1- and Z2-axes (assuming that the motor is linked to the Z1-axis)

• Master axis parking

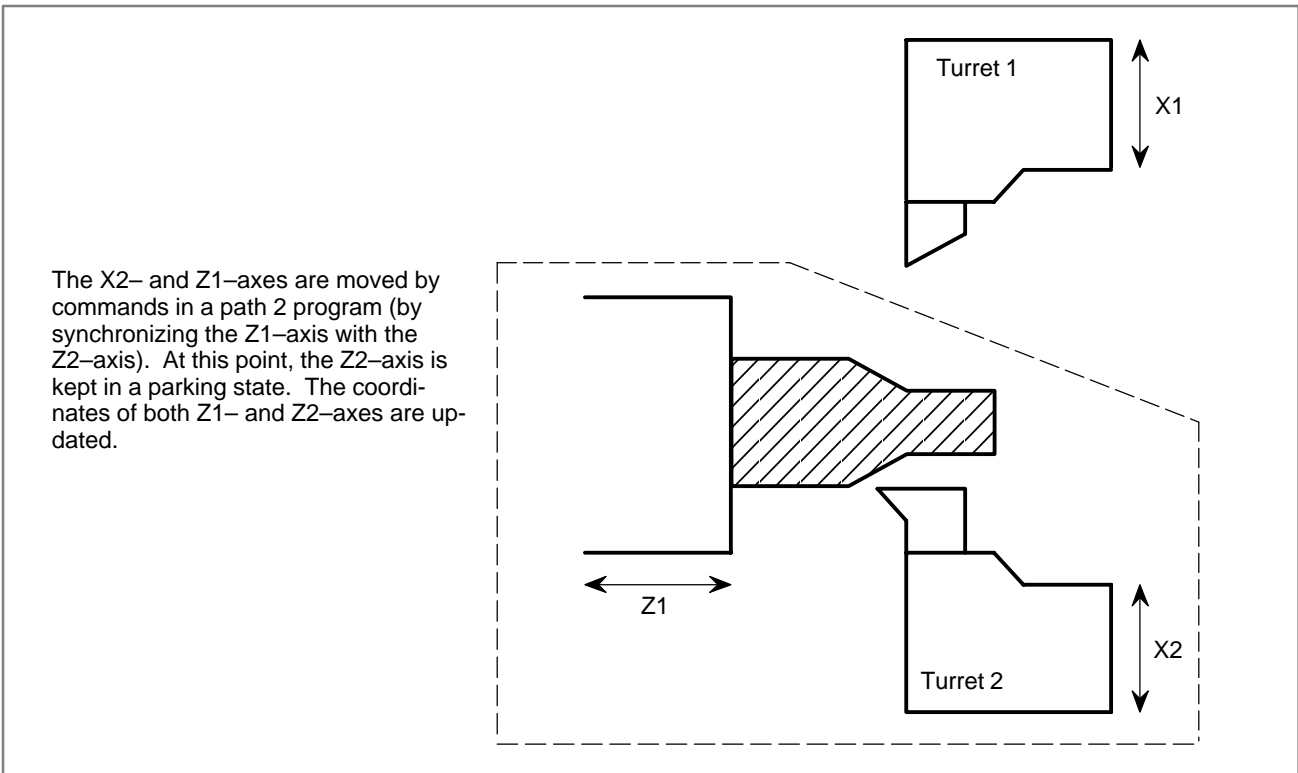

• Slave axis parking

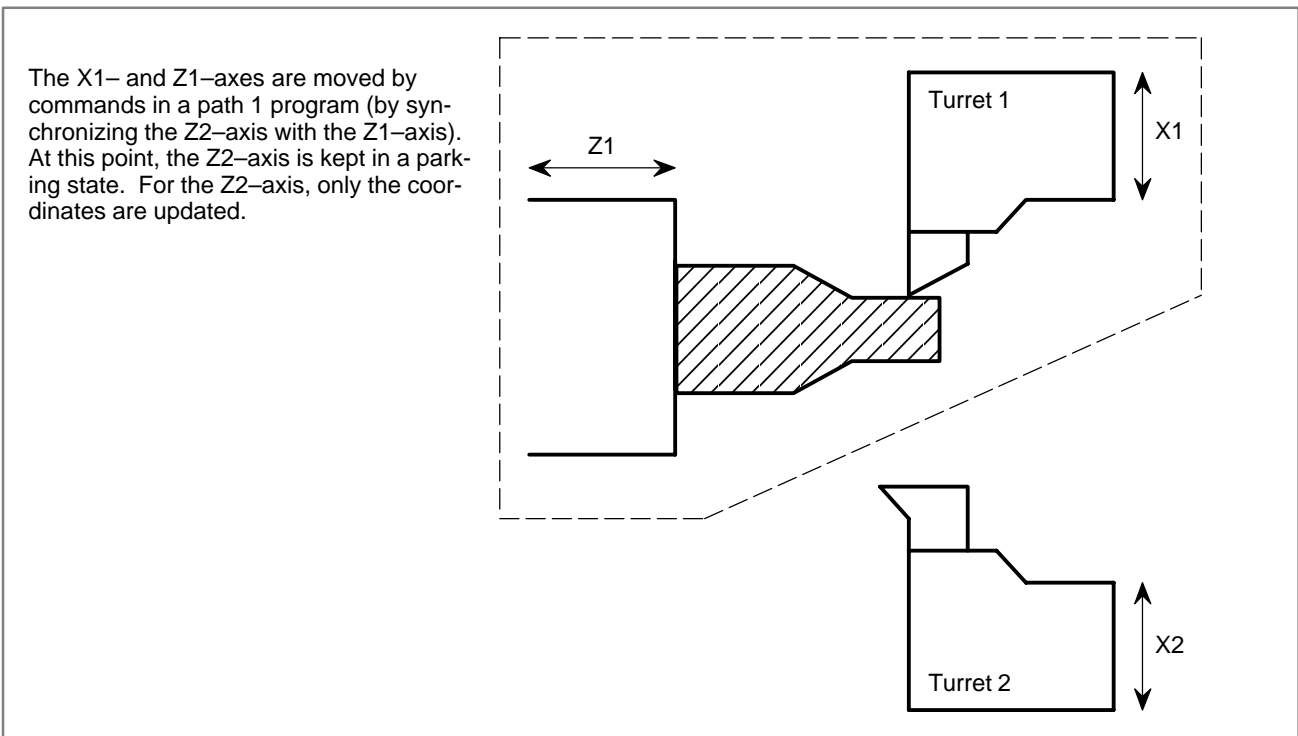

Because the coordinates of both Z1- and Z2-axes are updated, move commands can be executed immediately, without resetting up the coordinate system, when the synchronization state is switched.

Reference position return and its check during synchronous control

If a reference position return command is issued for a synchronous master axis during synchronous control, it is executed normally for the master axis, but the slave axis does not return to its reference position (the slave axis only moves in synchronization with the reference position return of the master axis). An exception is for automatic reference position return (G28) issued when the master axis is in a parking state, in which case the amount of movement is calculated so that the slave axis returns to its reference position provided that a reference position return has been carried for the slave axis. If more than one slave axis belongs to one master axis, a reference position return command is executed so that the lowest-numbered slave axis returns to its reference position. If the master axis in one path is subjected to both synchronization with an axis in the same path and synchronization with an axis in the other path simultaneously, the lowest-numbered slave axis in the two paths is moved to the reference position.

A return to the second (third or fourth) reference position by the G30 command works in the same way as G28. In other words, usually only the master axis moves to the second (third or fourth) reference position. If the master axis is parking, the lowest-numbered axis is caused to move to its second (third or fourth) reference position.

If a reference position return check (G27) is specified during synchronous control, the master and slave axes move to the specified position. Upon completion of movement, a check is made to see whether the master axis is at its reference position (no check is made for the slave axes) unless the master axis is in a parking state, in which case a check is made upon completion of positioning to see whether the lowest-numbered slave axis is at its reference position.

Out-of-synchronization detection

The term synchronous control used here only refers to an operation in which the same move command is issued to two different servo systems at one time. Note that synchronous control does not involve out-of-synchronization compensation, in which the positional deviation between two servo motors is constantly checked and one of the servo motors is subjected to compensation to reduce the deviation. However, using parameter SERx (bit 1 of parameter No. 8162) can specify detection of out-of-synchronization.

If out-of-synchronization is detected, synchronous control is immediately terminated, turning off the servo ready signal.

CAUTION

Out-of-synchronization detection is not applied to synchronous control within one path.

Move command after switching between independent control and synchronous control

If synchronous control is terminated during automatic operation, do not issue a move command or coordinate system setting for the synchronous slave axis in the current block and one or two (during tool–nose radius compensation) subsequent blocks. This restriction is intended to reflect the coordinates changed during synchronous control in the preprocessing for the subsequent blocks.

(Example) Terminating synchronous control of the Z–axis (slave axis) in block N200

```
N190 ..... ;
N200 M55 ; (This M code terminates synchronous control.)
N210 ..... ;
N220 ..... ;
N230 ..... ;
```

In this example, block N210 (and N220 during tool–nose radius compensation) cannot issue a move command to the Z–axis. However, if the M55 code does not involve buffering, it can be issued in block N210 to move the Z–axis or update its coordinates. For other than the Z–axis, block N210 can issue move commands. These restrictions do not apply to the synchronous master axis.

Automatic setting of a workpiece coordinate system

When synchronous control is started in a workpiece coordinate system, it is possible to specify the workpiece coordinate system automatically. When synchronous control for a workpiece coordinate system is terminated, it is possible to return the workpiece coordinate system to ordinary machining (not synchronous control). The explanation of the workpiece coordinate system used during synchronous control follows. When synchronous control is used to move an axis differently from the way originally specified, for example, the master axis may be placed in a parking state, while the slave axis is allowed to move. In such a case, it will be convenient if a coordinate system that indicates the current position of the slave axis is used as a workpiece coordinate system for the master axis. Conventionally, this workpiece coordinate system must be specified by program when synchronous control is started, because the workpiece coordinate system does not originally belong to the master axis. This automatic workpiece coordinate system setting function for synchronous control sets up this workpiece coordinate system automatically. This function can also resume the original workpiece coordinate system for the master axis automatically. This function does not work for the slave axis.

● Setting and commands

In addition to setting ordinary synchronous control, parameters must be specified as follows:

(1) To set up a workpiece coordinate system for synchronous control automatically when starting synchronous control

Set parameter SPMx (bit 1 of parameter No. 8163) to “1”.

Set parameter No. 8185 with the coordinates of the slave axis reference position relative to the coordinates of the master axis when the master axis is at the reference position.

(2) To resume the ordinary workpiece coordinate system automatically when terminating synchronous control

Set parameter SPSx (parameter No. 8163) to “1”.

Set parameter No. 1250 with the master axis coordinates in the workpiece coordinate system when the master axis is at the reference position.

This synchronous control can be specified using the synchronous control axis selection signal (SYNC1 to SYNC7) similarly to the ordinary synchronous control. When the signal is raised to start synchronous control, a workpiece coordinate system for the master axis is automatically set up. When the signal is dropped to terminate synchronous control, the original workpiece coordinate system for the master axis is resumed automatically.

- **Workpiece coordinate calculation method**

(1) Workpiece coordinate system for synchronous control

(Master axis workpiece coordinate value)

= (parameter No. 8185 for the master axis)

± (slave axis machine coordinate value) ①

+ (master axis machine coordinate value) ②

① +: Master axis parameter SCDx (bit 4 of parameter No. 8163) = 0

–: Master axis parameter SCDx (bit 3 of parameter No. 8163) = 1

② Master axis parameter SCMx (bit 3 of parameter No. 8163) = 1 only

(2) Workpiece coordinate system for ordinary operation

(Master axis workpiece coordinate value)

= (parameter No. 1250 for the master axis)

+ (master axis machine coordinate value)

Caution

CAUTION

- 1 The same least command and input increments must apply to both master and slave axes.
- 2 If synchronous control that involves automatic coordinate system setting is started or terminated during automatic operation, a move command or other commands that reference the current position of an axis may not be specified in the current block and the next one or two (during tool–nose radius compensation) blocks, except when the M code in the current block does not involve buffering.

Note**NOTE**

- 1 If more than one slave axis is synchronized with one master axis, the master axis is set with the workpiece coordinate system that corresponds to the current position of the first slave axis that is synchronized with the master axis.
- 2 The tool offset is taken into account when the coordinate system is set up. So, the coordinate system is set up normally even when tool geometry compensation is applied.

1.9.3 Composite Control

Move commands can be interchanged between an axis in one path and an axis in the other path. In other words, when a machining program is executed for one path, actual machining can be performed with an axis in the other path. Coordinate systems can also be switched automatically between independent control and composite control.

Setting

Parameter No. 8183 of path 2 specifies the axes between which commands are to be interchanged.

(Example) Between the X1- and X2-axes:

Parameter No. 8183x of path 2 = 1

Between the Y1- and X2-axes:

Parameter No. 8183x of path 2 = 4

Between The X1- and Y2-axes:

Parameter No. 8183y of path 2 = 1

To set up coordinate systems automatically when composite control begins or ends, set parameters MPMx and MPSx (bits 4 and 5 of parameter No. 8162) to "1", and specify the positional relationship between the coordinate systems in parameter No. 8184.

Programming

Use M codes for wait, beginning, and terminating composite control in a machining program in the stated order. It is also possible to begin and terminate composite control without using M codes.

Signal operation

When composite control begins or ends (when an M code is issued), the composite control axis selection signals MIX1 to MIX7 for the target axis in path 1 (from the PMC to the CNC) are changed from "0" to "1" (to begin composite control) or from "1" to "0" (to end composite control).

Examples of applications

Suppose that a machine has the X1- and Z1-axes belonging to path 1 and the X2- and Z2-axes belonging to path 2 and that a workpiece moves along the Z1- and Z2-axes as directed by move commands. The following examples interchange commands between the X1- and X2-axes.

(1) Independent control

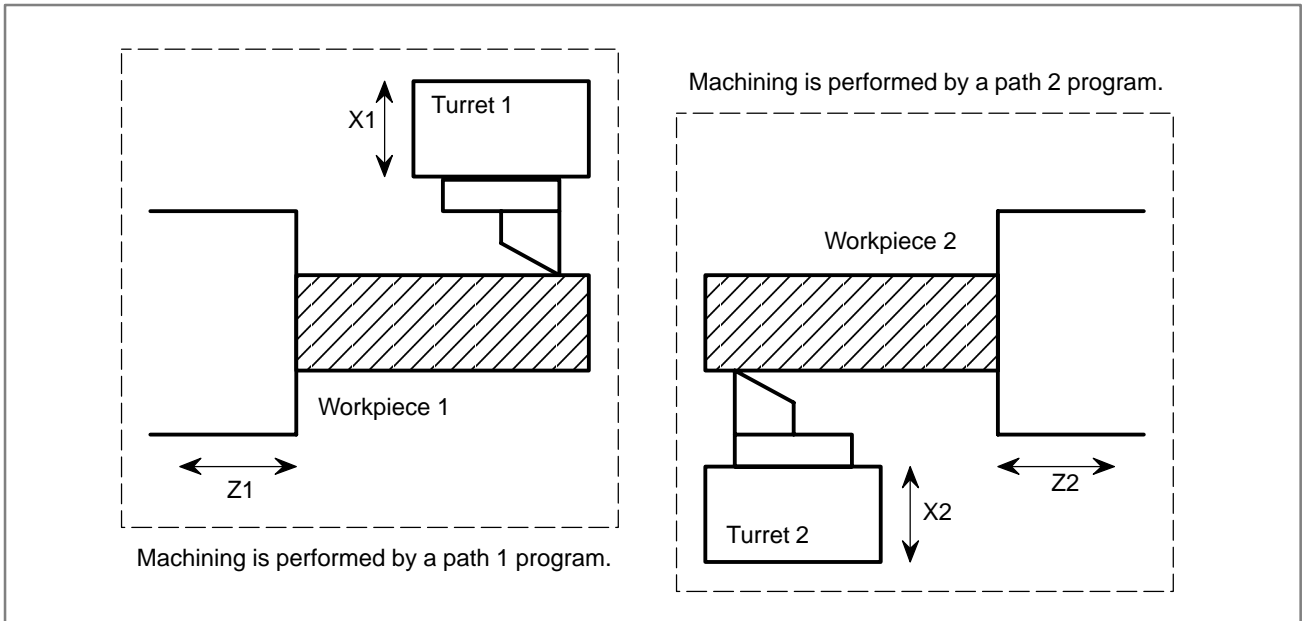

(2) Composite control

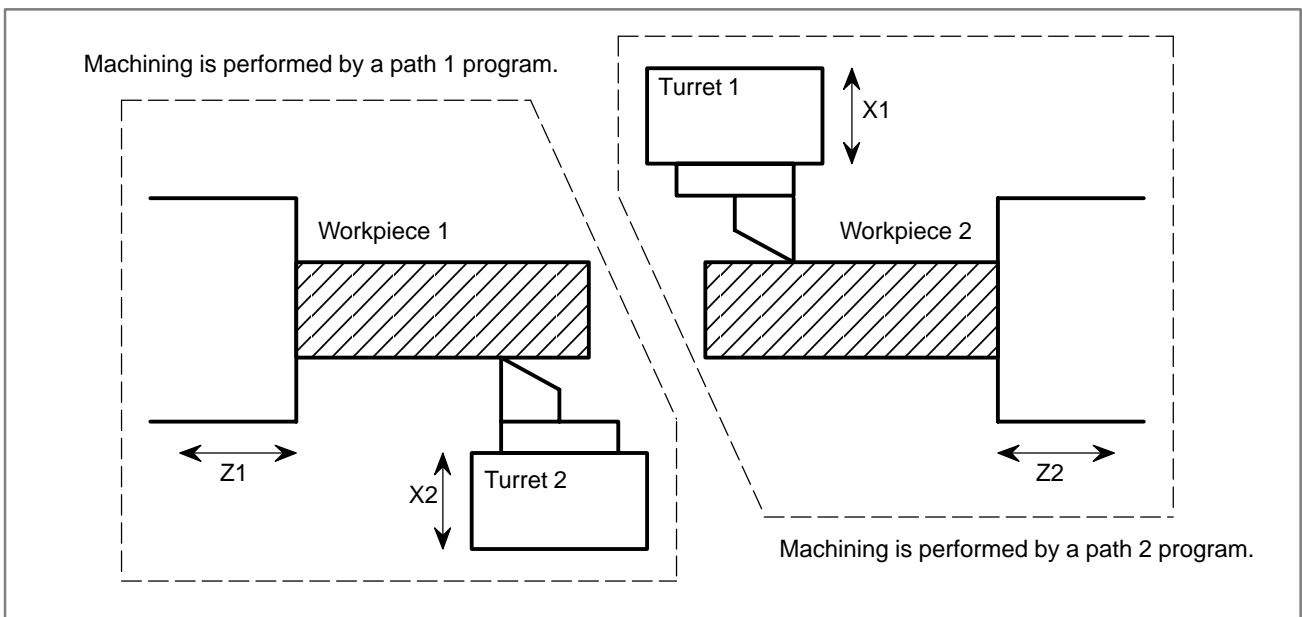

During composite control, the X2- and Z1-axes are moved by a path 1 program, and the workpiece coordinates of the X-axis in path 1 indicates the position of turret 2. Similarly, the X1- and Z2-axes are moved by a path 2 program, and the workpiece coordinates of the X-axis in path 2 indicates the position of turret 1.

Spindle control

The composite control function does not switch the spindle speed command or the feed per rotation command based on feedback pulses from the position coder. Therefore, the spindle speed command and feedback pulses should be switched using the following signals. (See Section 9.4.2 for details.)

- Spindle command selection signal SLSPA <G063#2> and SPSPB <G063#3>
- Spindle feedback selection signal SLPCA <G064#2> and SLPCB <G064#3>

Tool offset during composite control

A preset offset or tool-nose radius compensation is not changed when the control mode is switched between independent control and composite control. It is necessary to reset the offset using a T code after the control mode is switched.

Reference position return during composite control

If G28 is issued to specify an automatic reference position return for an axis in one path during composite control, an amount of movement is calculated so that the associated axis in the other path can move to the reference position. In this case, the reference position for that axis must have already been established. A manual reference position return is not allowed.

Move commands after the control mode is switched between independent control and composite control

If the control mode is switched between independent control and composite control during automatic operation, do not issue a move command or coordinate system setting for the switched axis in the current block and next one or two (during tool-nose radius compensation) subsequent blocks. This restriction is intended to reflect the coordinates changed due to coordinate system setting during control mode switching in the preprocessing for the subsequent blocks.

(Example) Starting composite control to switch between the X1- and X2-axes in block N200

```
N190 ..... ;
N200 M55 ; (This M code starts composite control.)
N210 ..... ;
N220 ..... ;
N230 ..... ;
```

In this example, block N210 (and N220 during tool-nose radius compensation) cannot issue a move command to the X-axis. However, if the M55 code does not involve buffering, it can be issued in block N210 to move the X-axis or update its coordinates. For other than the X-axis, block N210 can issue move commands.

1.9.4 Superimposed Control

The superimposed control function adds the amount of movement of an axis (superimposed control master axis) in one path to an axis (superimposed control slave axis) on the other path for which ordinary move commands are being executed. This function is similar to synchronous control but differs from it in that move commands can be issued not only for the master axis but also for the slave axis. The slave axis moves by the sum of the amount of movement specified by its own move commands and the amount of movement specified by move commands for the master axis. Appropriate setting of parameter OMRx (bit 3 of parameter No. 8162) can reverse the direction in which the master and slave axes move.

Setting

Parameter No. 8186 specifies between which axes move commands are to be superimposed.

(Example) To superimpose the amount of movement of the Z2-axis to that of the Z1-axis: Parameter No. 8186z of path 1 = 2
To superimpose the amount of movement of the X1-axis to that of the Y2-axis: Parameter No. 8186y of path 2 = 1

Programming

Use M codes for wait, beginning, and terminating superimposed control in a machining program in the stated order. It is also possible to begin and terminate superimposed control without using M codes.

Signal operation

When superimposed control begins or ends (when an M code is issued), the superimposed control axis selection signals OVLS1 to OVLS7 for the target slave axis (from the PMC to the CNC) are changed from “0” to “1” (to begin superimposed control) or from “1” to “0” (to terminate superimposed control).

Examples of applications

Suppose that a workpiece on the spindle (Z1-axis) that moves along the axis is to be cut with a tool in path 1 and a tool in path 2 simultaneously. This example superimposes the amount of movement of the Z1-axis on that of the Z2-axis.

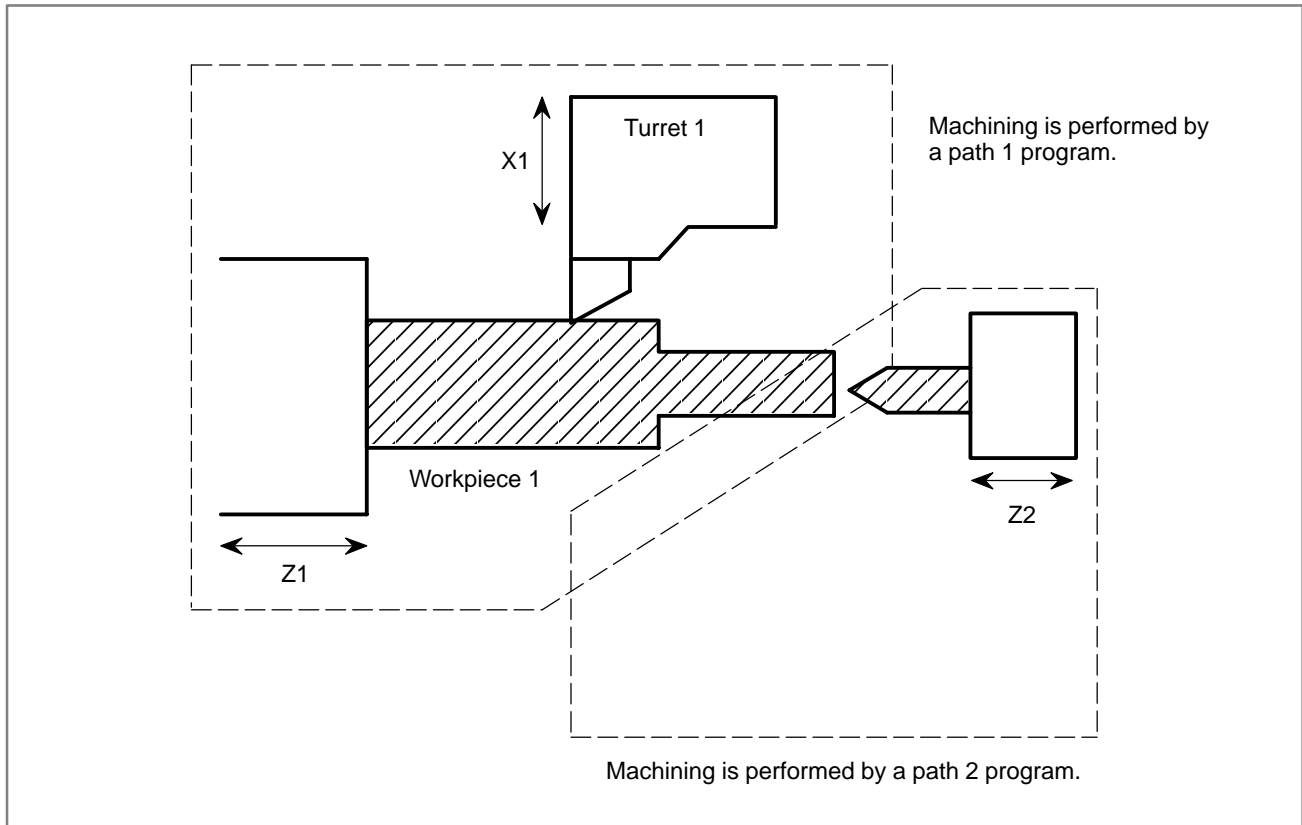

Feedrate

Because the amount of movement of the master axis is added to that of the slave axis, the resulting speed of the slave axis may become much larger than a normal speed (such as rapid traverse speed specified in a parameter). To solve this problem, it is necessary to set feedrates that are used only during superimposed control. The feedrates and time constants that are used only during superimposed control include:

- Rapid traverse rate: Parameter No. 8190
- Rapid traverse override F0 rate: parameter No. 8191
- Rapid traverse linear acceleration/deceleration time constant: Parameter No. 8192
- Maximum cutting feedrate: Parameter No. 8193
- Manual rapid traverse rate: Parameter No. 8190 or 1424 whichever is smaller

These special parameters are used for both master and slave axes during superimposed control. Appropriate values should be specified with the resulting feedrate taken into account. When superimposed control begins or ends during automatic operation, it is impossible to switch the maximum cutting feedrate in the current block and the next block. If an M code that does not involve buffering is used to direct superimposed control to begin or end, the maximum cutting feedrate is switched in a block next to the current block. The rates other than the maximum cutting feedrate are switched immediately when superimposed control begins or ends.

Differences between superimposed control and ordinary synchronous control

- Neither out-of-synchronization compensation or detection is performed between the master and slave axes during superimposed control.
- A parking signal is ineffective for axes under superimposed control.
- When superimposed control is terminated during automatic operation, move commands and coordinate system setting can be executed for the slave axis immediately. Unlike synchronous control, superimposed control does not inhibit move commands in the next one or two blocks.
- A reference position return cannot be specified for the slave axis under superimposed control.

1.9.5 Signal

Synchronous control axis selection signals SYNC1 to SYNC8 <G138#0 to G138#7>

[Classification] Input signal

[Function] These signals perform synchronous control.

[Operation] When one of these signals becomes “1”, the control unit:

- Begins synchronous control in such a way that the corresponding axis becomes a slave axis.

The axis with which the slave axis is synchronized is determined by parameter No. 8180.

Parking signals PK1 to PK8 <G122#0 to G122#7>

[Classification] Input signal

[Function] These signals place each axis in a parking state.

[Operation] When one of these signals becomes “1”, the control unit:

- Places the corresponding axis in a parking state.

If the corresponding axis is under synchronous control, it enters a parking state immediately regardless of whether the axis is moving. If a parking signal is set to “1” without specifying synchronous control, it is ignored.

**Composite control axis
selection signal MIX1 to
MIX8 <G128#0 to
G128#7>**

[Classification] Input signal

[Function] These signals perform composite control.

[Operation] When one of these signals becomes “1”, the control unit:

- Begins composite control over the corresponding axis.

The axis with which the corresponding axis is controlled together is determined by parameter No. 8183.

<p>NOTE</p>

<p>These signals are available only for path 1.</p>

**Superimposed control
axis selection signals
OVLS1 to OVLS8
<G190#0 to G190#7>**

[Classification] Input signal

[Function] These signals perform superimposed control.

[Operation] When one of these signals becomes “1”, the control unit:

- Begins superimposed control over the corresponding axis.

The master axis is selected according to parameter No. 8186.

**Synchronous/composite/
superimposed control
under way signals
SYN10 to SYN80
<F118#0 to F118#7>**

[Classification] Output signal

[Function] These signals indicate each axis is being subjected to synchronous/composite/superimposed control.

[Output condition] These signals become “1” under the following condition:

- The corresponding axis is under synchronous, composite, or superimposed control.

These signals become “0” under the following condition:

- The corresponding axis is not under synchronous, composite, or superimposed control.

CAUTION

Whether each axis is under synchronous, composite, or superimposed control does not always match whether the corresponding selection signal (synchronous control axis selection, composite control axis selection, or superimposed control axis selection signal) has been issued or not. For example, if these signals are set to “1” during an alarm, they are ignored. If a servo alarm occurs during these types of control, they are terminated automatically. Before attempting to perform these types of control, always check the state of these signals.

Signal address

	#7	#6	#5	#4	#3	#2	#1	#0
G122	PK8	PK7	PK6	PK5	PK4	PK3	PK2	PK1
G128	MIX8	MIX7	MIX6	MIX5	MIX4	MIX3	MIX2	MIX1
G138	SYNC8	SYNC7	SYNC6	SYNC5	SYNC4	SYNC3	SYNC2	SYNC1
G190	OVLS8	OVLS7	OVLS6	OVLS5	OVLS4	OVLS3	OVLS2	OVLS1
	#7	#6	#5	#4	#3	#2	#1	#0
F118	SYN8O	SYN7O	SYN6O	SYN5O	SYN4O	SYN3O	SYN2O	SYN1O

1.9.6

Parameter

	#7	#6	#5	#4	#3	#2	#1	#0
8160	NRS	SPE				ZSI	XSI	MXC

[Data type] Bit

MXC During mixed control of the X- or Z-axis, measurement direct input function B for tool compensation performs calculation based on:

- 0 : Machine coordinates for the path being controlled
- 1 : Machine coordinates for another path subject to mixed control

NOTE

- 1 This parameter is valid for setting tool compensation values for the X- or Z axis and setting shift of the workpiece coordinate system for the Z-axis in direct input of tool offset value function B.
- 2 This parameter cannot be used when mixed control is applied to paths for which different minimum command increments (metric or inch) are specified.

XSI When $MXC = 1$, the machine coordinates along the X-axis for the other path subject to mixed control are fetched:

- 0 : With the sign as is
- 1 : With the sign inverted

ZSI When $MXC = 1$, machine coordinates along the Z-axis for the other path subject to mixed control are fetched:

- 0 : With the sign as is
- 1 : With the sign inverted

SPE The synchronization deviation is:

- 0 : The difference between the positioning deviation of the master axis and that of the slave axis.
- 1 : The difference between the positioning deviation of the master axis and that of the slave axis plus the acceleration/deceleration delay.

NOTE

When the master and slave axes have different acceleration/deceleration time constants, set 1.

NRS When the system is reset, synchronous, composite, or superimposed control is:

- 0 : Released.
- 1 : Not released.

	#7	#6	#5	#4	#3	#2	#1	#0
8161							CZM	NMR

[Data type] Bit

NMR When an axis subject to mixed control is placed in servo-off state:

- 0 : Mixed control is stopped.
- 1 : Mixed control is not stopped, provided bit 0 (FUP) of parameter No. 1819 is set to 1 to disable follow-up for the axis.

NOTE

Mixed control is not stopped only when bit 0 (FUP) of parameter No. 1819 is set to 1. If follow-up is disabled with the follow-up signal (*FLWU <G007 bit 5> =1), mixed control is stopped.

CZM When two Cs contour axes are subject to mixed control, the function for mixing reference position return commands for Cs contour axes is:

- 0 : Not used
- 1 : Used

	#7	#6	#5	#4	#3	#2	#1	#0
8162	MUMx	MCDx	MPSx	MPMx	OMRx	PKUx	SERx	SMRx

[Data type] Bit axis

SMRx Synchronous mirror-image control is:

- 0 : Not applied. (The master and slave axes move in the same direction.)
- 1 : Applied. (The master and slave axes move in opposite directions.)

- SERx** The synchronization deviation is:
 0 : Not detected.
 1 : Detected.

NOTE

When both master and slave axes move in synchronization, the positioning deviations of the corresponding axes are compared with each other. If the difference is larger than or equal to the value specified in parameter No. 8181, an alarm occurs. When either axis is in the parking or machine-locked state, however, the synchronization deviation is not detected.

- PKUx** In the parking state,
 0 : The absolute, relative, and machine coordinates are not updated.
 1 : The absolute and relative coordinates are updated. The machine coordinates are not updated.

WARNING

Set the parameter to 1 for any axes for which polar coordinate interpolation will be specified. Otherwise, coordinates may shift when single block stop or feed hold is specified in polar coordinate interpolation mode.

- OMRx** Superimposed mirror-image control is:
 0 : Not applied. (The superimposed pulse is simply added.)
 1 : Applied. (The inverted superimposed pulse is added.)
- MPMx** When composite control is started, the workpiece coordinate system is:
 0 : Not set automatically.
 1 : Set automatically.

NOTE

When the workpiece coordinate system is automatically set at the start of composite control, it is calculated from the following: Current machine coordinates and the workpiece coordinates at the reference point of each axis (parameter No. 8184).

- MPSx** When composite control is terminated, the workpiece coordinate system is:
 0 : Not set automatically.
 1 : Set automatically.

NOTE

When the workpiece coordinate system is automatically set at the end of composite control, it is calculated from the following: Current machine coordinates and the workpiece coordinates at the reference point of each axis under composite control (parameter No. 1250)

MCDx The axes to be replaced with each other under composite control have the coordinate systems placed:

0 : In the same direction. Simple composite control is applied. (The axes of paths 1 and 2 move in the same direction.)

1 : In opposite directions. Mirror-image composite control is applied. (The axes of paths 1 and 2 move in opposite directions.)

This parameter determines the direction in which an axis moves. The parameter is also used to automatically set the coordinate system when composite control is started or terminated.

[Example]

MCDz and MCDz are set in accordance with the relationship among the X- and Y-axes of tool posts 1 and 2, as indicated in the figure below. (Swapping the X-axis and Z-axis with their counterparts respectively)

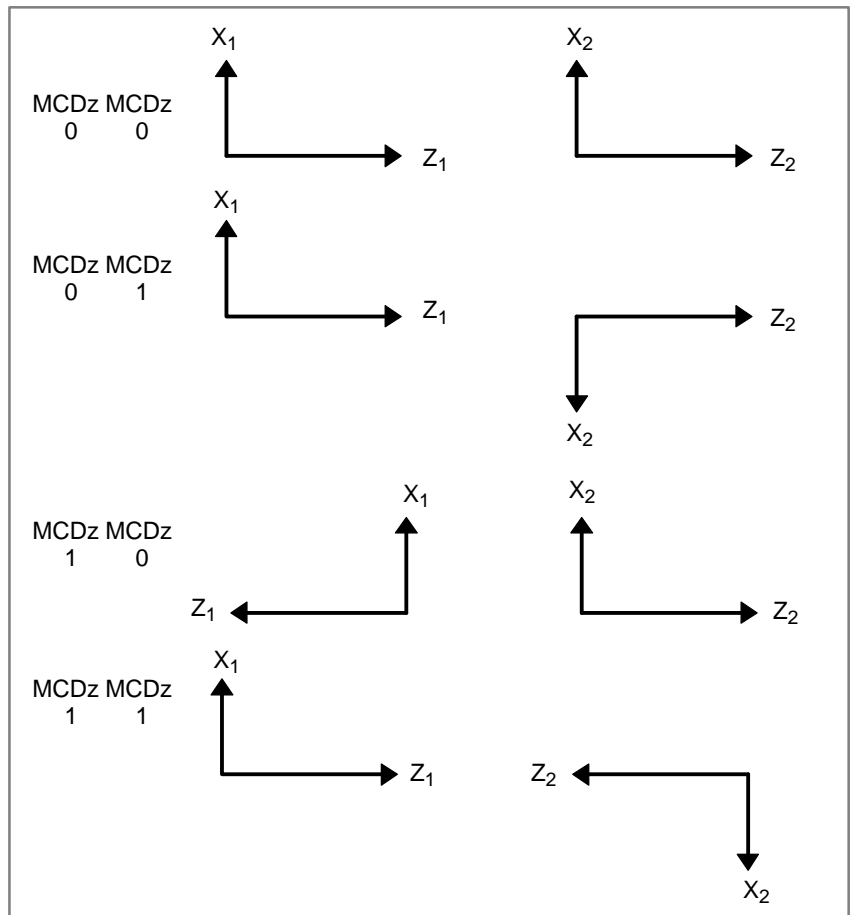

MUMx In mixed control, a move command for the axis:

0 : Can be specified.

1 : Cannot be specified.

NOTE

Upon the execution of a move command along an axis for which MUMx is set to 1 during mixed control, alarm P/S 226 is issued. If the X1-axis and X2-axis are under mixed control, for example, a command for the X2-axis (X1-axis motor) is disabled by setting the MUMx parameter for tool post No. 2 to 1.

	#7	#6	#5	#4	#3	#2	#1	#0
8163				SCDx	SCMx	SPSx	SPMx	MDXx

[Data type] Bit axis

MDXx In mixed control, the current position (absolute/relative coordinates) display indicates:

- 0 : Coordinates in the local system.
- 1 : Coordinates in the other system under mixed control.

SPMx When synchronous control is started, automatic workpiece coordinate system setting for the master axis is

- 0 : Not Performed.
- 1 : Performed.

NOTE

When a workpiece coordinate system is automatically set at the start of synchronous control, the workpiece coordinate system is calculated from the current machine coordinates and the workpiece coordinates of each axis at the reference position set in parameter No. 8185.

SPSx When synchronous control terminates, automatic workpiece coordinate system setting for the master axis is:

- 0 : Not performed.
- 1 : Performed.

NOTE

When a workpiece coordinate system is automatically set at the end of synchronous control, the workpiece coordinate system is calculated from the current machine coordinates and the workpiece coordinates for each axis at the reference position set in parameter No. 1250.

SCMx When workpiece coordinates are calculated in synchronous control:

- 0 : The workpiece coordinates are calculated from the machine coordinates of the slave axis.
- 1 : The workpiece coordinates are calculated from the machine coordinates of the master axis and slave axis.

SCDx The positive (+) directions of the master axis and slave axis in the coordinate system in synchronous control are:

- 0 : Identical.
- 1 : Opposite.

Parameters SPMx, SPSx, SCMx, and SCDx must be specified for the master axis. These parameter settings are referenced in automatic setting of the workpiece coordinates for the master axis when synchronization control begins.

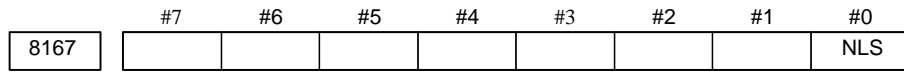

[Data type] Bit axis

NLS For an axis under composite control, acceleration/deceleration with a constant time for linear interpolation type rapid traverse (bit 4 (PRT) of parameter No. 1603) is:
 0 : Enabled.
 1 : Disabled.

Example: When composite control is exercised on the C1 axis and X2 axis

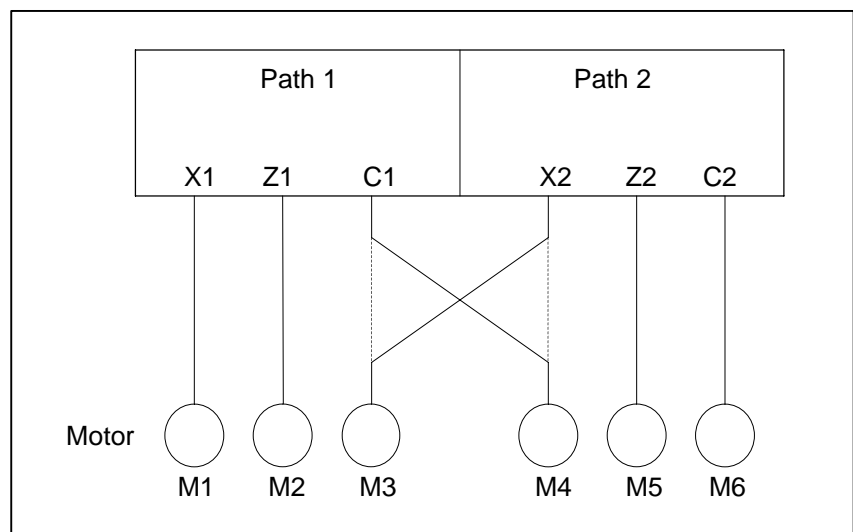

To disable the acceleration/deceleration with a constant time of motor M3, set bit 0(x) of parameter No. 8167 to 1. Similarly, to disable the acceleration/deceleration with a constant time of motor M4, set bit 0(c) of parameter No. 8167 to 1.

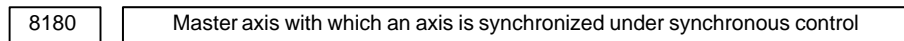

[Data type] Byte axis

[Valid data range] 1, 2, 3, ... to the maximum number of control axes, or 201, 202, 203, ... to 200 plus the maximum number of control axes

This parameter specifies the number of the master axis with which an axis is synchronized. When zero is specified, the axis does not become a slave axis and is not synchronized with another axis. When an identical number is specified in two or more axes, one master axis has two or more slave axes.

- Exercising synchronous control between two paths
 In the parameter of a slave axis, specify the axis number of the master axis with which the slave axis is to be synchronized.
 Setting: 1 to 8
 The value specified here must not exceed the maximum number of control axes.

(Example 1) Synchronizing the Z₂-axis with the Z₁-axis

Path 1	Path 2
Parameter No. 8180x 0	Parameter No. 8180x 0
Parameter No. 8180z 0	Parameter No. 8180z 2
Parameter No. 8180c 0	Parameter No. 8180c 0
Parameter No. 8180y 0	Parameter No. 8180y 0

- Exercising synchronous control in a path

In the parameter of a slave axis, specify 200 plus the number of the master axis with which the slave axis is to be synchronized.

Setting: 201 to 208

The value specified here must not exceed 200 plus the maximum number of control axes.

(Example 1) Synchronizing the Y₁-axis with the Z₁-axis

Path 1	Path 2
Parameter No. 8180x 0	Parameter No. 8180x 0
Parameter No. 8180z 0	Parameter No. 8180z 0
Parameter No. 8180c 0	Parameter No. 8180c 0
Parameter No. 8180y 202	Parameter No. 8180y 0

8181

Synchronization error limit of each axis (Synchronous or composite control)

[Data type] Two-word axis

[Unit of data] Unit of detection

[Valid data range] 0 to 32767

When the synchronization deviation detected (SERx of Bit #1 parameter No. 8162 is set to 1), this parameter specifies the limit of the difference between the positioning deviation of the slave axis and that of the master axis. Set this parameter for the slave axis.

8182

Display of the synchronization error of an axis (synchronous or composite control)

[Data type] Two-word axis

[Unit of data] Unit of detection

[Valid data range] 0 or more

When the synchronization deviation is detected (SERx of Bit #1 parameter No. 8162 is set to 1), this parameter specifies the difference between the positioning deviation of the slave axis and that of the master axis. (The value is used for diagnosis.) The deviation is displayed on the slave side

The parameter is only for the display.

The difference between the positioning deviation is:

(Positioning deviation of the master axis) \pm (Positioning deviation of the slave axis)



Plus for a mirror-image synchronization command

Minus for a simple synchronization command

8183	Axis under composite control in path 1 corresponding to an axis of path 2
------	---

[Data type] Byte axis

[Valid data range] 1, 2, 3, ... to the maximum number of control axes

This parameter specifies an axis of path 1 to be placed under composite control with each axis of path 2. The value specified here must not exceed the maximum number of axes that can be used in path 1. When zero is specified, control of the axis is not replaced under composite control. An identical number can be specified in two or more axes, but composite control cannot be exercised for all of them at a time.

NOTE
Specify this parameter only for path 2.

(Example 1) Exercising composite control to replace the X₁-axis with the X₂-axis

Path 1	Path 2
Parameter No. 8183x 0	Parameter No. 8183x 1
Parameter No. 8183z 0	Parameter No. 8183z 0
Parameter No. 8183c 0	Parameter No. 8183c 0
Parameter No. 8183y 0	Parameter No. 8183y 0

(Example 2) Exercising composite control to replace the Y₁-axis with the X₂-axis

Path 1	Path 2
Parameter No. 8183x 0	Parameter No. 8183x 4
Parameter No. 8183z 0	Parameter No. 8183z 0
Parameter No. 8183c 0	Parameter No. 8183c 0
Parameter No. 8183y 0	Parameter No. 8183y 0

8184	Coordinates of the reference point of an axis on the coordinate system of another axis under composite control
------	--

[Data type] Two-word axis

[Unit of data]	Increment system	IS-A	IS-B	IS-C	Unit
	Millimeter machine	0.01	0.001	0.0001	mm
	Inch machine	0.001	0.0001	0.00001	inch
	Rotation axis	0.01	0.001	0.0001	deg

[Valid data range] -99999999 to 99999999

This parameter specifies the coordinates of the reference point of an axis on the coordinate system of another axis under composite control. The parameter is validated when MPMx of bit 4 parameter No. 8162 is set to 1.

(Example) Exercising composite control to replace the X_1 -axis with the X_2 -axis

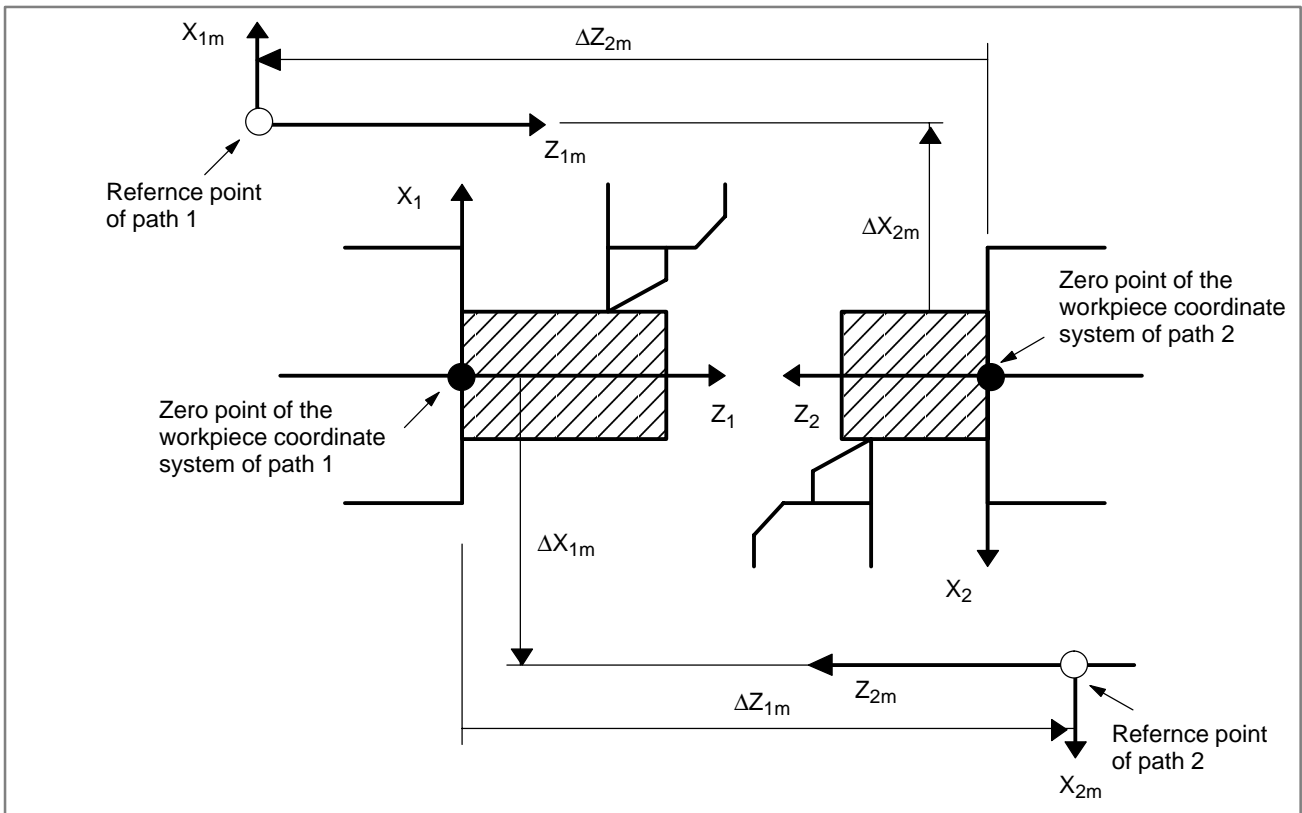

$(\Delta X_{1m}, \Delta Z_{1m})$ are the coordinates of the reference point of path 2 on the workpiece coordinate system of path 1. $(\Delta X_{2m}, \Delta Z_{2m})$ are the coordinates of the reference point of path 1 on the workpiece coordinate system of path 2.

ΔX_{1m} is specified for the X-axis of path 1 and ΔX_{2m} for the X-axis of path 2.

If bit 4 of parameter No. 8162 MPMx is set to 1 when composite control is started, the workpiece coordinate system satisfying the following conditions is specified:

$$X_1 = (\text{Value specified for the X-axis of path 1}) \pm (\text{Machine coordinates of } X_2)$$

↑
 Plus when parameter No. 8162#6 MCDx of path 1 is set to 0
 Minus when parameter No. 8162#6 MCDx of path 1 is set to 1

$$X_2 = (\text{Value specified for the X-axis of path 2}) \pm (\text{Machine coordinates of } X_1)$$

↑
 Plus when parameter No. 8162#6 MCDx of path 2 is set to 0
 Minus when parameter No. 8162#6 MCDx of path 2 is set to 1

If bit 5 of parameter No. 8162 MPSx is set to 1 when composite control is terminated, the workpiece coordinate system satisfying the following conditions is specified:

$$X_1 = \text{Parameter No. 1250 of path 1} + \text{Machine coordinate of } X_1$$

$$X_2 = \text{Parameter No. 1250 of path 2} + \text{Machine coordinate of } X_2$$

8185	Workpiece coordinates on each axis at the reference position
------	--

[Data type] Two-word axis

[Unit of data]	Increment system	IS-A	IS-B	IS-C	Unit
	Millimeter machine	0.01	0.001	0.0001	mm
	Inch machine	0.001	0.0001	0.00001	inch
	Rotation axis	0.01	0.001	0.0001	deg

[Valid data range] -99999999 to 99999999

This parameter specifies the reference position coordinates along the slave axes, according to the workpiece coordinate system for the master axis, when the tool is positioned to the reference position along the master axis. This parameter is enabled when SPMx of bit 1 parameter No. 8163 is set to 1. Set this parameter for the master axis.

8186	Master axis under superimposed control
------	--

[Data type] Byte axis

[Valid data range] 1, 2, 3, ... to number of control axes

This parameter specifies the axis number of an axis that functions as a master axis for other axes to be put under superimposed control. If an axis is set with 0, it cannot work as a slave axis to which the movement pulses of another axis under superimposed control are assigned. The same axis number can be set in two or more parameters, but the axis cannot be subjected to superimposed control with two or more other axes at a time. To put another way, it is impossible to use such superimposed control that one master axis and two or more slave axes are involved.

(Example) Superimposed control where the travel distance for the Z₁-axis is superimposed onto the Z₂-axis

Path 1	Path 2
Parameter No. 8186x 0	Parameter No. 8186x 0
Parameter No. 8186z 0	Parameter No. 8186z 2
Parameter No. 8186c 0	Parameter No. 8186c 0
Parameter No. 8186y 0	Parameter No. 8186y 0

8190

Rapid traverse rate of an axis under superimposed control

[Data type] Two-word axis**[Unit of data]****[Valid data range]**

Increment system	Unit of data	Valid data range	
		IS-A, IS-B	IS-C
Millimeter machine	1 mm/min	30 to 240000	30 to 100000
Inch machine	0.1 inch/min	30 to 96000	30 to 48000
Rotation axis	1 deg/min	30 to 240000	30 to 100000

Set a rapid traverse rate for each of the axes when the rapid traverse override of the axes (master and slave axes) under superimposed control is 100%. A manual rapid traverse rate depends on this parameter or No. 1424 (When No. 1424 is set to 0, No. 1420) whichever is smaller.

8191

F0 velocity of rapid traverse override of an axis under superimposed control

[Data type] Word axis**[Unit of data]****[Valid data range]**

Increment system	Unit of data	Valid data range	
		IS-A, IS-B	IS-C
Millimeter machine	1 mm/min	6 to 15000	6 to 12000
Inch machine	0.1 inch/min	6 to 6000	6 to 4800
Rotation axis	1 deg/min	6 to 150000	6 to 12000

This parameter specifies the F0 velocity of rapid traverse override for each of the axes (master and slave axes) under superimposed control.

8192

Linear acceleration/deceleration time constant in rapid traverse of an axis under superimposed control

[Data type] Word axis**[Unit of data]** ms**[Valid data range]** 0 to 4000

This parameter specifies the linear acceleration/deceleration time constant in rapid traverse for each of the axes (master and slave axes) under superimposed control.

8193

Maximum cutting feedrate under superimposed control

[Data type] Two-word**[Unit of data]****[Valid data range]**

Increment system	Unit of data	Valid data range	
		IS-A, IS-B	IS-C
Millimeter machine	1 mm/min	30 to 240000	30 to 100000
Inch machine	0.1 inch/min	30 to 96000	30 to 48000
Rotation axis	1 deg/min	30 to 240000	30 to 100000

This parameter specifies the maximum cutting feedrate under superimposed control.

1.9.7 Alarms and messages

If one of the alarms listed below occurs, it terminates synchronous, composite, and superimposed control for all axes.

P/S alarms

Number	Message	Description
225	Synchronous or composite control error	<p>This alarm occurs under either of the following conditions (detected when synchronous, composite, or superimposed control is terminated).</p> <p>(1) There is an error in an axis number parameter (parameter No. 1023).</p> <p>(2) An invalid control command is issued.</p> <p>If this alarm occurs when synchronous, composite, or superimposed control is terminated, place the machine in an emergency stop state before resetting the alarm.</p>
226	A move command was issued to a synchronous axis.	<p>When an axis is in a synchronization mode, a move command was issued to that axis. (Only during synchronous control)</p> <p>During composite control, a move command was issued to an axis for which parameter MUMx (bit 7 of parameter No. 8162) is "1". (Only during composite control)</p> <p>In a control mode other than synchronous or composite control, a move command was issued to an axis for which parameter NUMx (bit 7 of parameter No. 8163) was "1".</p>
229	Synchronization cannot be maintained.	<p>This alarm occurs under either of the following conditions.</p> <p>(1) Synchronous or composite control cannot be maintained because of system overload.</p> <p>(2) Synchronous or composite control cannot be maintained because of a hardware failure. (This alarm does occur during normal use.)</p>
000	Turn the power off.	<p>This message is issued if superimposed control is suspended because of an alarm that occurs when the axis is moving. Turn the power of the CNC off, then on gain.</p>

Servo alarms

Number	Message	Description
407	Servo alarm: Excessive error	A positional deviation for a synchronous axis exceeded the specified value. (Only during synchronous control).

**1.9.8
Definition of Warning,
Caution, and Note**

**Items common to
synchronous,
composite, and
superimposed control****WARNING**

- 1 When synchronous, composite, or superimposed control begins or ends, the target axes must be at a stop.
- 2 All axes subjected to synchronous, composite, or superimposed control must have the same least command, detection increment, and diameter/radius specification. Otherwise, the amount of movement will differ from one axis to another.
- 3 When an axis is under synchronous, composite, or superimposed control, do not change the parameters related to that axis.
- 4 Before starting synchronous, composite, or superimposed control, make sure that for the target axis a reference position return after power-on has been made or a reference position has been set up according to the absolute pulse coder.
- 5 Before starting synchronous, composite, or superimposed control after an emergency stop, servo-off, or servo alarm is released, be sure to make a return to the reference position and set up the necessary coordinate system.
- 6 Acceleration/deceleration control, pitch error compensation, backlash compensation, and stored stroke limit check are carried out regardless of synchronous or composite control. During superimposed control, these operations except acceleration/deceleration are performed on the position where superimposed pulses have been added.
- 7 The following servo software functions cannot be used for synchronization control, composite control, or superposition control.
 - Feed-forward function
 - Advanced feed-forward function
 - Fine acceleration/deceleration
 - Function for switching abnormal-load detection by cutting and rapid traverse
 - Learning-control function
 - Function for switching fine acceleration/deceleration by cutting and rapid traverse
 - Function for switching speed and gain by cutting and rapid traverse
 - Function for switching current and PI by cutting and rapid traverse
 - Function for switching the torque command filter by cutting and rapid traverse
 - Learning tandem function
- 8 Advanced preview control cannot be used together with synchronization control, composite control, or superposition control.

NOTE

- 1 More than one axis can be subjected to synchronous, composite, or superimposed control. On the other hand, an axis cannot be synchronized with more than one axis simultaneously. Moreover, an axis under composite control cannot be synchronized with another axis or cannot doubly be subjected to composite control.
- 2 Synchronous, composite, or superimposed control cannot be performed between a linear axis and a rotation axis.
- 3 Synchronous, composite, or superimposed control cannot be specified simultaneously with simplified synchronous control. Synchronous control within one path provides the same functions as simplified synchronous control.

Items related only to synchronous control**CAUTION**

- 1 The same acceleration/deceleration time constants and servo parameters should be used for axes subjected to synchronous control as much as possible. If there is a large difference in a set value between the axes, a deviation will occur in the actual movement of the machine.
- 2 The workpiece coordinate system of a synchronous slave axis is not affected by the synchronous master axis operations that affect workpiece coordinate systems but do not cause the machine to move, such as workpiece coordinate system set/shift and geometry offset commands.
- 3 If a wear offset command or tool-nose radius compensation is performed for the synchronous master axis, the travel path of the slave axis is shifted by the offset, but the shift is not set as an offset (no offset vector is created).
- 4 A move command should not be issued to a synchronous slave axis during synchronous control.

Restrictions imposed during synchronous, composite, and superimposed control

Function	During synchronous control	During composite control	During superimposed control
Acceleration/deceleration control	The acceleration/deceleration control for the master axis is performed also for the synchronous slave axes, but different time constants are used.	The acceleration/deceleration control originally specified for one path is used also for the other path, but different time constants are used (*3).	The move pulses that are effective after acceleration/deceleration for the superimposed control master axis are added to those for the slave axes.
Linear acceleration/deceleration after cutting feed interpolation	Possible	Possible	Possible
Feedrate clamping	The axes are clamped at the feedrate of the master axis.	The axes in both paths are clamped at the feedrate originally specified for one path (*4).	The axes are clamped to the feedrate specified for superimposed control.
Reference position return	A reference position return is possible for the master axis unless it is in a parking state. If the master axis is in a parking state, only automatic reference position return (G28) is possible for the master axis. (⇒ Section 1.9.2.5)	A reference position return is possible for axes not under composite control. For axes under composite control, only an automatic reference position return (G28) is possible.	Impossible for superimposed control slave axes.
Second-, third-, or fourth-reference position return	Possible (⇒ 1.9.2.5).	Possible	Impossible for superimposed control slave axes.
Reference position return check	Possible (⇒ 1.9.2.5).	Possible	Impossible for superimposed control slave axes.
PMC axis control	Possible for other than synchronous slave axes.	Possible	Possible
Polar coordinate interpolation and cylindrical interpolation	Possible	Switching between independent control and composite control should be carried out during cancel mode.	Possible
Handle interrupt	Performed regardless of synchronous control.	Possible for axes having nothing to do with composite control.	Performed regardless of superimposed control (*5).
Mirror image	Each signal originally belonging to a particular axis is effective for that axis (*1).	Signals originally specified for one path are effective for the other path (*4).	Signals for the master axis are effective as superimposed control pulses (*5).
Machine lock	Each signal originally belonging to a particular axis is effective for that axis (*1).	Signals originally specified for one path are effective for the other path (*4).	Signals for the master axis are effective as superimposed control pulses (*5).

Function	During synchronous control	During composite control	During superimposed control
Interlock	The signals for the synchronous master axis are effective for the synchronous slave axes (*2).	Signals originally specified for one path are effective for the other path (*4).	Signals for the master axis are effective as superimposed control pulses (*5).
Override	The signals for the synchronous master axis are effective for the synchronous slave axes (*2).	Signals originally specified for one path are effective for the other path (*4).	Signals for the master axis are effective as superimposed control pulses (*5).
External deceleration	The signals for the synchronous master axis are effective for the synchronous slave axes (*2).	Signals originally specified for one path are effective for the other path (*4).	Signals for the master axis are effective as superimposed control pulses (*5).
Skip function	Impossible for slave axes.	Possible for axes having nothing to do with composite control.	Possible.
Automatic tool compensation	Impossible for slave axes.	Possible for axes having nothing to do with composite control.	Impossible for superimposed control slave axes.
Direct tool compensation measurement input B	Impossible for slave axes.	Possible (*7)	Impossible for superimposed control slave axes.
Follow-up	Impossible during synchronous control.	Impossible during composite control.	Impossible during superimposed control.
Program restart	Impossible for a program involving synchronous control.	Impossible for a program involving composite control.	Impossible for a program involving superimposed control.
Cs contour control	Synchronous control is possible (*6).	Composite control is possible (*6).	Superimposed control is possible (*6).
Spindle positioning	Synchronous control is impossible.	Composite control is impossible.	Superimposed control is impossible.

(*1) Processed after synchronization pulses are sent to the slave axes.

(*2) After it is processed on the master side, synchronization pulses are sent.

(*3) Composite control pulses and acceleration/deceleration type are sent. The time constant for the slave axis is used.

(*4) Composite control pulses are sent after being processed on the master side.

(*5) Performed normally for move commands originally intended for the master or slave axes, but not performed on the slave side for superimposed control pulses received from the master axis.

(*6) Restricted to a combination of Cs axes. Necessary signal operations and orientation should be performed for each axis separately. Also specify parameter CZM (bit 1 of parameter No. 8161).

(*7) Specify parameters MXC, XSI, and ZSI (bits 0, 1, and 2 of parameter No. 8160).

Reading the coordinates during synchronous, composite, or superimposed control

The following list summarizes how positional information such as custom macro system variables and current coordinates from the PMC window are read during synchronous, composite, or superimposed control.

Positional information	During synchronous control	During composite control	During superimposed control
Absolute coordinate	Readable	Readable (*1)	Readable (*2)
Machine coordinate	Readable	Readable	Readable
End of each block	Readable only for the master axis	Readable (*1)	Readable (*2)
Skip signal position	Readable only for the master axis	Unreadable	Readable (*2)

(*1) The coordinates are represented in the coordinate system that is effective during composite control. Their relationship with the machine coordinate system differs from the relationship that exists during independent control.

(*2) No superimposed control pulse is added.

Terminating synchronous, composite, or superimposed control

Synchronous, composite, or superimposed control is terminated not only when the corresponding synchronization signal becomes off but also when the following conditions occur.

- (1) Emergency stop
- (2) Reset
- (3) Servo alarm
- (4) Servo off (*1)
- (5) Overtravel
- (6) Alarm related to synchronous, composite, or superimposed control
- (7) P/S000 alarm

If one of the above conditions occurs for either path, it terminates synchronous control, composite, and superimposed control for all axes. If one of the above conditions occurs for one path during synchronous, composite, or superimposed control, the other path is placed in a feed hold state (during automatic operation) or interlock state (during manual operation).

(*1) Setting parameter NMR (bit 0 of parameter No. 8161) specifies that synchronous, composite, or superimposed control be not terminated even when an axis under composite control enters a servo-off state. (If an axis under synchronous or superimposed control enters a servo-off state, synchronous, composite, and superimposed control is terminated.)

Status output signals for an axis under synchronous, composite, or superimposed control

Status output signal	During synchronous control	During composite control	During superimposed control
Axis moving signal MVn F0102/F1102 (See Section 1.2.5.)	<ul style="list-style-type: none"> The master axis moving signal becomes "1" when the master or slave axis is moving. The slave axis moving signal is always "0" (*1). 	<ul style="list-style-type: none"> The moving signal for an axis to which a move command is originally issued becomes "1". The moving signal for the axis that is actually moving does not become "1" (*1). 	<ul style="list-style-type: none"> The master axis moving signal works as usual. The slave axis moving signal reflects the state of movement due to a command for the slave axis rather than superimposed control pulses.
Axis movement direction signal MVDn F0106/F1106 (See Section 1.2.5.)	<ul style="list-style-type: none"> The master axis movement direction signal indicates the direction in which the master axis is moving. The slave axis movement direction signal indicates the direction of movement after synchronous control mirror image processing. 	<ul style="list-style-type: none"> The axis movement direction signal indicates the actual movement direction (that is, direction after composite control mirror image processing). 	<ul style="list-style-type: none"> The master axis movement direction signal indicates the direction in which the master axis is moving. The slave axis movement direction signal indicates the direction of movement after superimposed control pulses are added.
Axis in position signal INPn F0104/F1104 (See Section 7.2.6.1.)	<ul style="list-style-type: none"> The master axis in position signal becomes "1" when both master and slave axes are in position. The slave axis in position signal is always "1". 	<ul style="list-style-type: none"> The in position signal for an axis in a path for which a move command is issued reflects the state of the axis that is driven by that move command. 	<ul style="list-style-type: none"> The master axis in position signal works as usual. The slave axis in position signal is always "1".

(*1) A positional deviation check does not depend on the state of this signal. If move command pulses have been output to a motor (either master or slave), parameter No. 1828 is used as a limit. Otherwise, parameter No. 1829 is used.

1.9.9 Examples of Applications

Independent control and synchronous control of the Z1- and Z2-axes

(1) Machine configuration

(a) Independent control

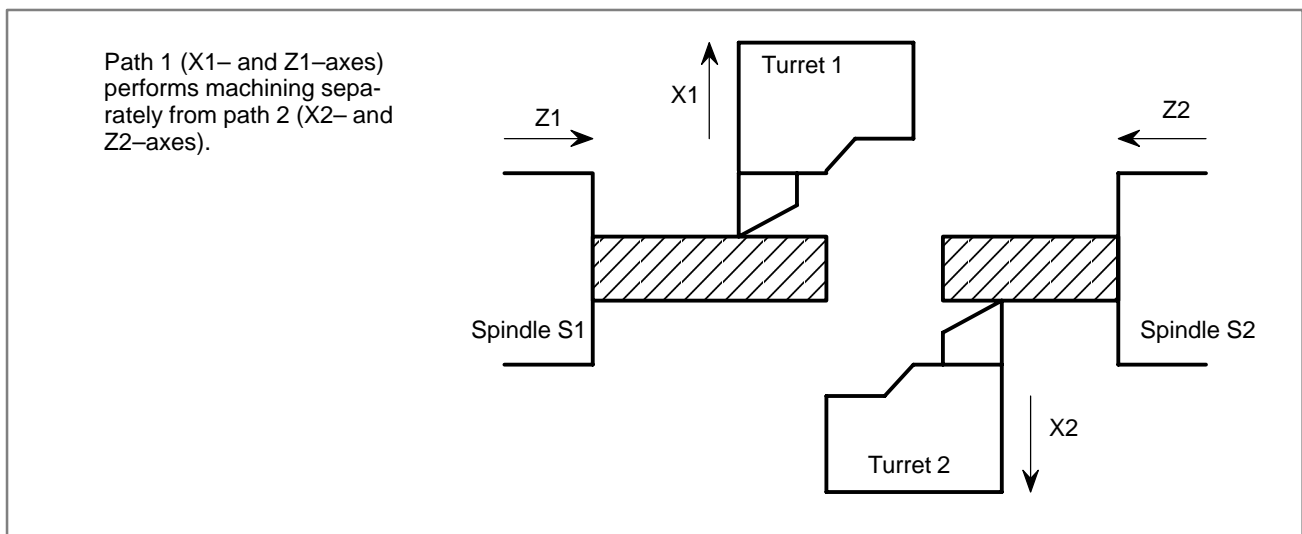

(b) Synchronous control of the Z1- and Z2-axes

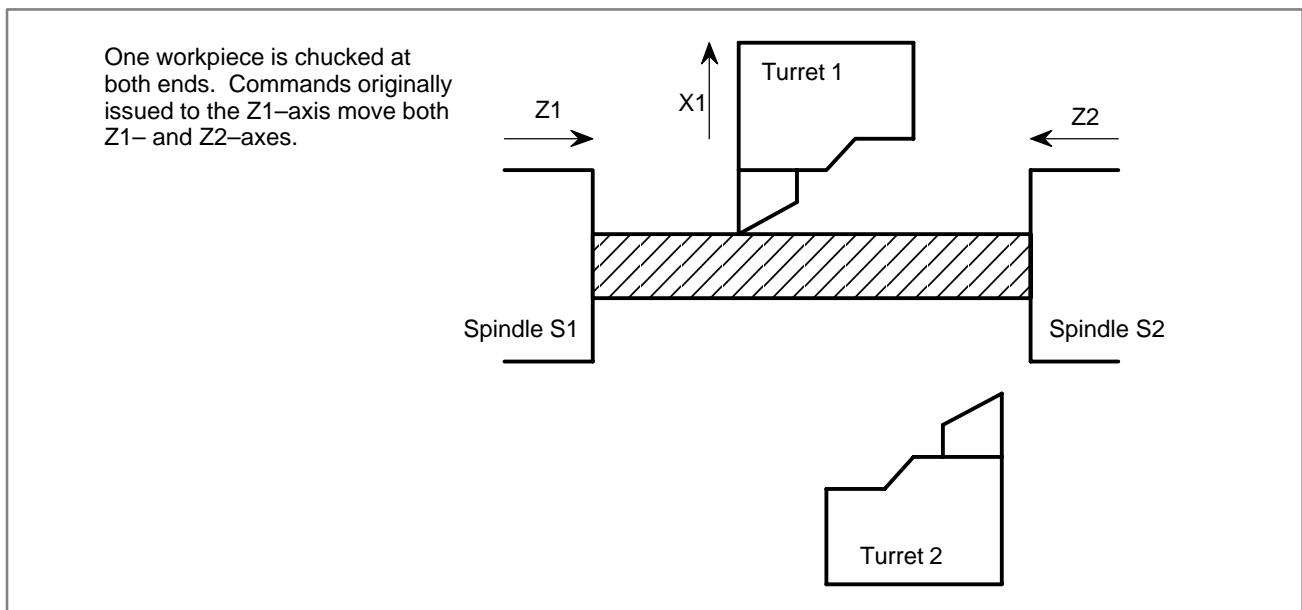

(2) Parameter setting

- To synchronize the Z2-axis with the Z1-axis, set parameter No. 8180z of path 2 to "2".

- To apply mirror-image synchronization (because initially the positive direction of one axis is opposite to that of the other axis), set SMRz (bit 0 of parameter No. 8162) of path 2 to “1”.
- To detect out-of-synchronization (because both axes should move by the same amount), set SERz (bit 1 of parameter No. 8162) to “1”. Set a value from 100 to 1000 as a limit to out-of-synchronization in parameter No. 8181z of path 2 (this limit varies from one machine to another).
- A difference in the positional deviation between the Z1- and Z2-axes is indicated in parameter No. 8182z during synchronization.

(3) Signal operation

- Set signal G1138#1 SYNC2 to “1” when the Z1- and Z2-axes start moving in synchronization.
- Reset signal G1138#1 SYNC2 to “0” when synchronization is terminated.
- Also reset signal G1138#1 SYNC2 to “0” if an emergency stop, NC reset, or alarm occurs.
- Keep signals other than G1138#1 SYNC2 reset to “0”.

(4) Sample program

<u>Path 1</u>	<u>Path 2</u>	
N1000	N2000	Machining under control independent of the other path
N1010 Z80. ;	N2010 Z150. ;	Moves the workpiece and chuck to the specified position.
N1020 M200 ;	N2020 M200 ;	Waits for completion of movement.
N1030 M61 ;		Clamps the workpiece and begins synchronization
N1040 M3 S800 ;		Turns the spindle in normal direction.
N1050 Z- 25. ;		Moves the Z1-axis.
N1060		Machining with the X1- and Z1-axes
N1070 M62 ;		Terminates synchronization and unclamps the workpiece.
N1080 M201 ;	N2080 M201 ;	Waits for synchronization to be terminated.
N1090 ;	N2090 ;	Dummy block (performing no move command)
N1100	N2100	Machining under control independent of the other path

In this example, assume that M61 clamps the workpiece and sets signal G1138#1 SYNC2 to “1” and that M62 resets signal G1138#1 SYNC2 to “0” and unclamps the workpiece.

NOTE

It is necessary to make the speed of spindle S1 equal that of spindle S2. For example, issue spindle commands of path 1 to both S1 and S2.

Independent control and interpolation for the X1- and Z2-axes

- (1) Machine configuration
- (a) Independent control

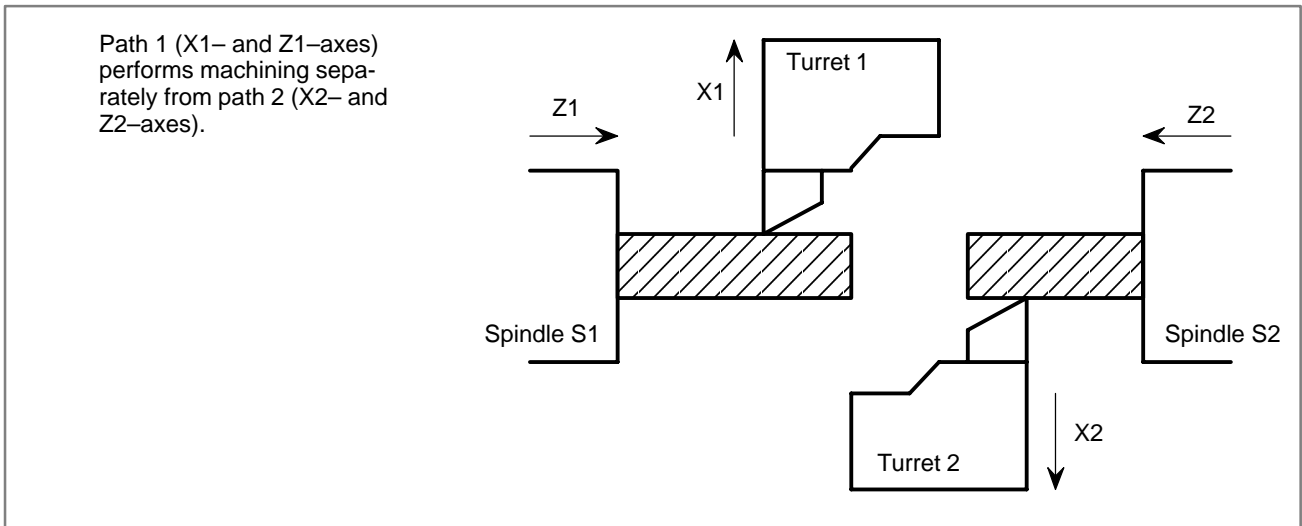

(b) Interpolation for the X1- and Z2-axes

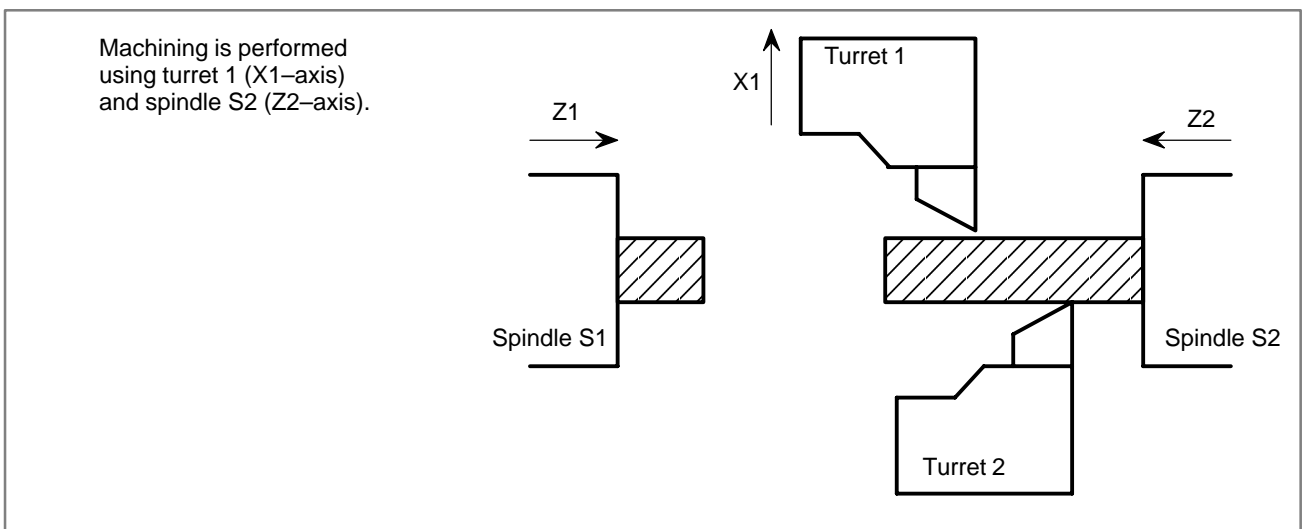

Interpolation for the X1- and Z2-axes can be carried out by either of the following two methods.

1. The path 2 program directs the X2- and Z2-axes, synchronizes the X1-axis with the X2-axis, and causes the X2-axis to park. The path 1 program issues no move command.
2. Composite control is performed in which move commands are switched between the X1-axis in one path and the X2-axis in the other path. Path 1 does not issue move commands.

The following sections describe a case in which synchronous control is used and a case in which composite control is used, separately.

Using synchronous control

(1) Parameter setting

- To synchronize the X1-axis with the X2-axis, set parameter No. 8180x of path 1 to "1".
- Do not specify mirror image, because for both X1- and X2-axes, the direction in which they go away from the workpiece center is defined as positive.
- Do not specify out-of-synchronization detection for the X2-axis because it is caused to park.
- Parameter No. 8182x indicates a difference in the positional deviation between the X2- and X1-axes during synchronous control.

(2) Signal operation

- Set signals G0138#0 SYNC1 and G1122#0 PK1 to "1" when synchronous control begins for the X2- and X1-axes.
- Reset signals G0138#0 SYNC1 and G1122#0 PK1 to "0" when synchronization is terminated.
- Also reset signals G0138#0 SYNC1 and G1122#0 PK1 to "0" if an emergency stop, NC reset, or alarm occurs.
- Keep signals other than G0138#0 SYNC1 or G1122#0 PK1 reset to "0".

(3) Sample program

<u>Path 1</u>	<u>Path 2</u>	
N1000	N2000	Machining under control independent of the other path
N1010 Z0 ;	N2010 Z20. ;	Moves the workpiece to the specified position.
N1020 X120. ;	N2020 X120. ;	Moves each X-axis to their start position for synchronization (X1 = X2)
N1030 M200 ;	N2030 M200 ;	Waits for completion of movement.
	N2040 M55 ;	Synchronizes the X2- and X1-axes and causes the X2-axis to park.

	N2050 T0212 ;	Specifies an offset for turret 1.
	N2060 S1000 M4 ;	Reverses the spindle.
	N2070 G0 X30. Z55. ;	} Performs machining using the X1- and Z2-axes.
	N2080 G1 F0.2 W-15. ;	
	N2090	
	N2100 M56 ;	Terminates synchronization and parking.
N1110 M201 ;	N2110 M201 ;	Waits for synchronization to be terminated.
N1120 ;	N2120 ;	Dummy block (performing no move command)
N1130	N2130	Machining under control independent of the other path

In this example, assume that M55 begins control of turret 1 in path 2 and that M56 terminates control of turret 1 in path 2.

NOTE

When the X-axis is under synchronous control, path 1 cannot issue a move command to the X1-axis, but can move the Z1-axis.

Using composite control

(1) Parameter setting

- To specify composite control in which commands for the X1-axis are interchanged with those of the X2-axis, set parameter No. 8183x of path 2 to "1".
- Set MCDx (bit 6 of parameter No. 8162) of path 2 to "1", because the direction of the X1-axis is opposite to that of the X2-axis.
- To cause the position of turret 1 to be specified automatically in the workpiece coordinate system in path 2 when composite control begins, set MPSx (bit 5 of parameter No. 8162) to "1".
- To cause the position of turret 1 to be specified automatically in the workpiece coordinate system in path 1 when composite control ends, set MPMx (bit 4 of parameter No. 8162) to "1".
- Assuming that the X-coordinate of the reference position of turret 1 in the workpiece coordinate system in path 2 is -150.0 mm as shown below, set "-150000" in parameter No. 8184x of path 2 for automatic coordinate system setting.

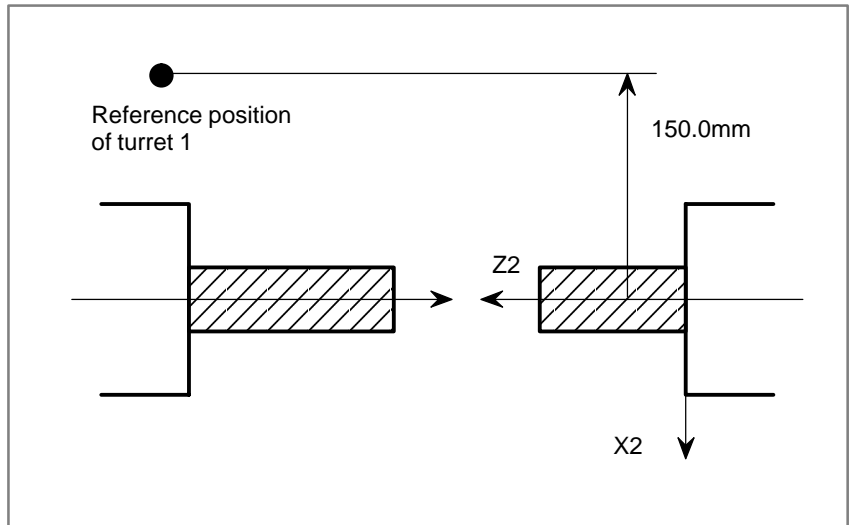

(2) Signal operation

- Set signal G0128#0 MIX1 to “1” when composite control begins for the X2- and X1-axes.
- Reset signal G0128#0 MIX1 to “0” when composite control ends.
- Also reset G0128#0 MIX1 to “0” when an emergency stop, NC reset, or alarm occurs.
- Keep signals other than G0128#0 MIX1 reset to “0”.

(3) Sample program

<u>Path 1</u>	<u>Path 2</u>	
N1000	N2000	Machining under control independent of the other path
N1010 Z0 ;	N2010 Z20. ;	Moves each workpiece to the specified position.
	N2020 X120. ;	Moves the X2-axis to a position where no interference occurs.
N1030 M200 ;	N2030 M200 ;	Waits for completion of movement.
	N2040 M55 ;	Begins composite control of the X2- and X1-axes (the position of turret 1 is set up as workpiece coordinates in path 2.)
	N2050 ;	Dummy block (performing no move command)
	N2060 T0212 ;	Specifies an offset for turret 1.
	N2070 S1000 M4 ;	} Performs machining using the X1- and Z2-axes.
	N2080 G0 U10. W- 20. ;	
	N2090 G1 F0.2 W- 15. ;	
	N2100	

	N2110 M56 ;	Terminates composite control (the position of turret 1 is set up as workpiece coordinates in path 1.)
N1120 M201;	N2120 M201 ;	Waits for composite control to be terminated.
N1130 ;	N2130 ;	Dummy block (performing no move command)
N1140	N2140	Machining under control independent of the other path

In this example, assume that M55 begins control of turret 1 by a path 2 program and that M56 terminates control of turret 1 by a path 2 program.

NOTE

- 1 It is not always necessary to cause a coordinate system to be set up automatically when composite control begins or ends. If automatic coordinate system setting is not specified, an appropriate coordinate system is set by program.
- 2 When the X-axis is under composite control, the X2-axis can be moved in path 1 using move commands for the X-axis.
- 3 The above parameter setting specifies that turret 1 is located on the negative side of the X-coordinate in the workpiece coordinate system of path 2. So, for example, to move turret 1 toward the center of the workpiece, specify U+10, and to move it away from the center, specify U-10 (note the sign is a minus). If this is inconvenient, set the following parameters as follows:
 Bit 6 of parameter No. 8162 (MCDx) = 0
 Parameter No. 8184x = 150000
 This parameter setting specifies that turret 1 be located virtually on the positive side of the X-coordinate.

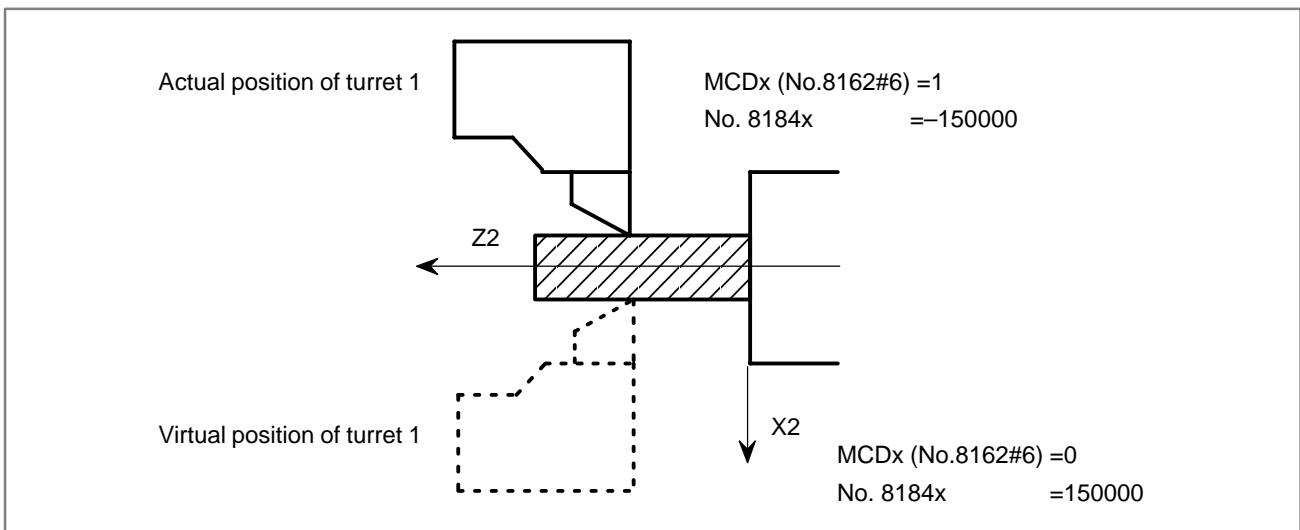

Independent control and interpolation between the X1- and Z2-axes and between the X2- and Z1-axes

(1) Machine configuration
(a) Independent control

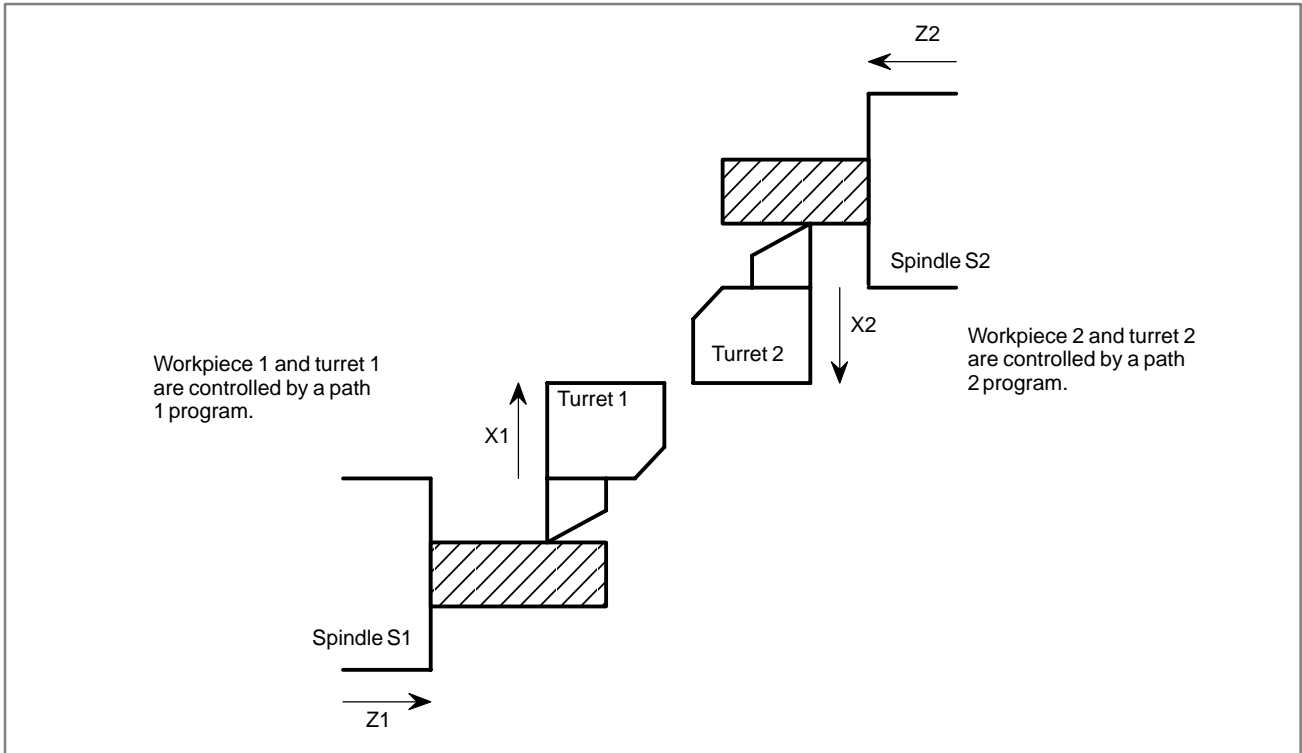

(b) Interpolation between the X1- and Z2-axes and between the X2- and Z1-axes

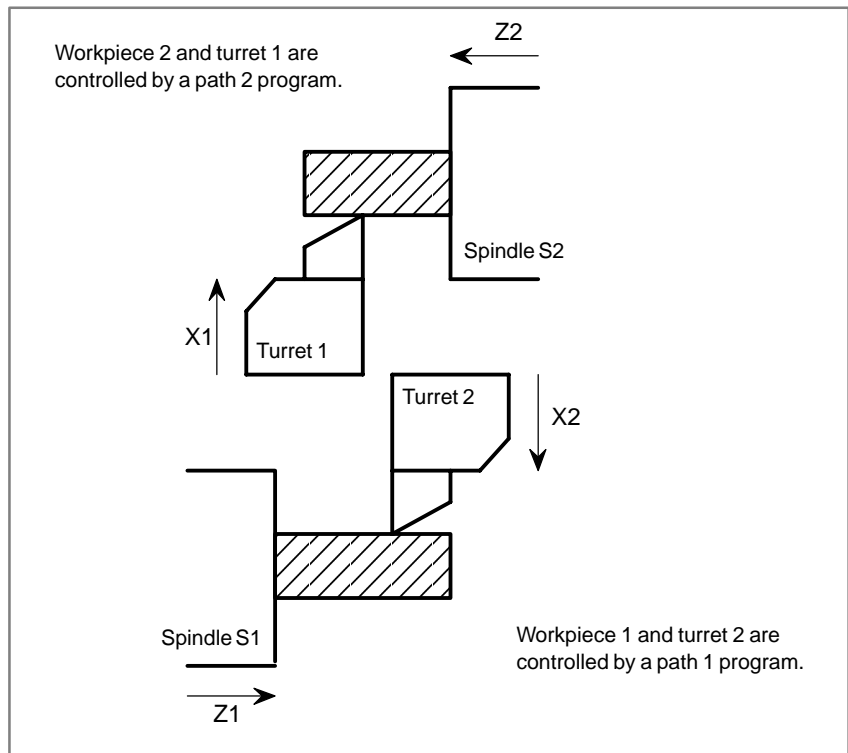

(2) Parameter setting

- To specify composite control in which commands for the X1-axis are interchanged with those for the X2-axis, set parameter No. 8183x of path 2 to “1”.
- Set MCDx (bit 6 of parameter No. 8162) of paths 1 and 2 to “1”, because the direction of the X1-axis is opposite to that of the X2-axis.
- To cause the position of a turret in one path to be specified automatically in the workpiece coordinate system of the other path when composite control begins, set MPMx (bit 4 of parameter No. 8162) to “1”.
- To cause the position of a turret in each path to be specified automatically in the workpiece coordinate system of that path when composite control ends, set MPSx (bit 5 of parameter No. 8162) to “1”.
- Assuming that the relationships between the workpiece coordinates and reference position of each path are as shown below, set “200000” in parameter No. 8184x of path 1 and “180000” in parameter No. 8184x of path 2 for automatic coordinate system setting.

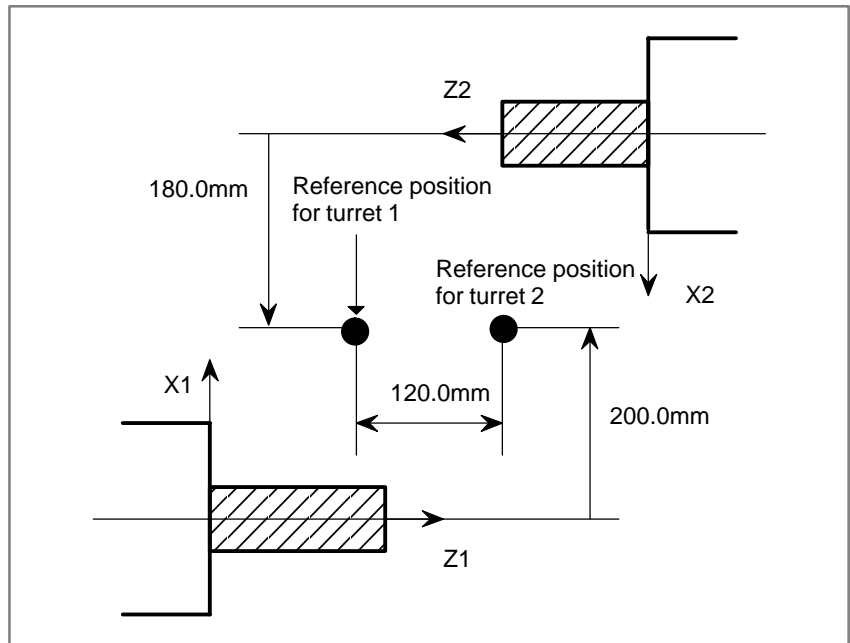

(3) Signal operation

- Set signal G0128#0 MIX1 to “1” when composite control begins for the X2- and X1-axes.
- Reset signal G0128#0 MIX1 to “0” when composite control ends.
- Also reset G0128#0 MIX1 to “0” when an emergency stop, NC reset, or alarm occurs.
- Keep signals other than G0128#0 MIX1 reset to “0”.

(4) Sample program

<u>Path 1</u>	<u>Path 2</u>	
N1000	N2000	Machining under control independent of the other path
N1010 M350 ;	N2010 M350 ;	Waits for composite control to begin.
	N2020 M55 ;	Begins composite control for the X1- and X2-axes.
N1030 M351 ;	N2030 M351 ;	Composite control has begun.
N1040 ;	N2040 ;	Dummy block (performing no move command)

N1050 T0313	N2050 T0212 ;	Selects a tool for composite control and sets the offset.
N1060 G50 W120. ;	N2060 G50 W120. ;	Shifts the Z-axis workpiece coordinate system.
N1070 S1000 M4 ;	N2070 S1500 M4 ;	} Performs machining under composite control.
N1080 G0 X20. Z15. ;	N2080 G0 X15. Z30. ;	
N1090 G1 F0.5 W- 8. ;	N2090 G1 F0.1 W- 5. ;	
N1100	N2100	
N1110 M360 ;	N2110 M360 ;	Waits for composite control to be terminated.
	N2120 M56 ;	Terminates composite control.
N1130 M361 ;	N2130 M361 ;	Composite control has ended.
N1140 ;	N2140 ;	Dummy block (performing no move command)
N1150 G50 W- 120. ;	N2150 G50 W- 120. ;	Shifts the Z-axis workpiece coordinate system.
N1160	N2160	Machining under control independent of the other path

In this example, assume that M55 begins composite control (sets signal G0128#0 MIX1 to “1”) and that M56 terminates composite control (resets signal G0128#0 MIX1 to “0”).

NOTE

It is not always necessary to cause a coordinate system to be set up automatically when composite control begins or ends. If automatic coordinate system setting is not specified, an appropriate coordinate system is set by program.

Independent control and superimposed control for the Z1- and Z2-axes

(1) Machine configuration

(a) Independent control

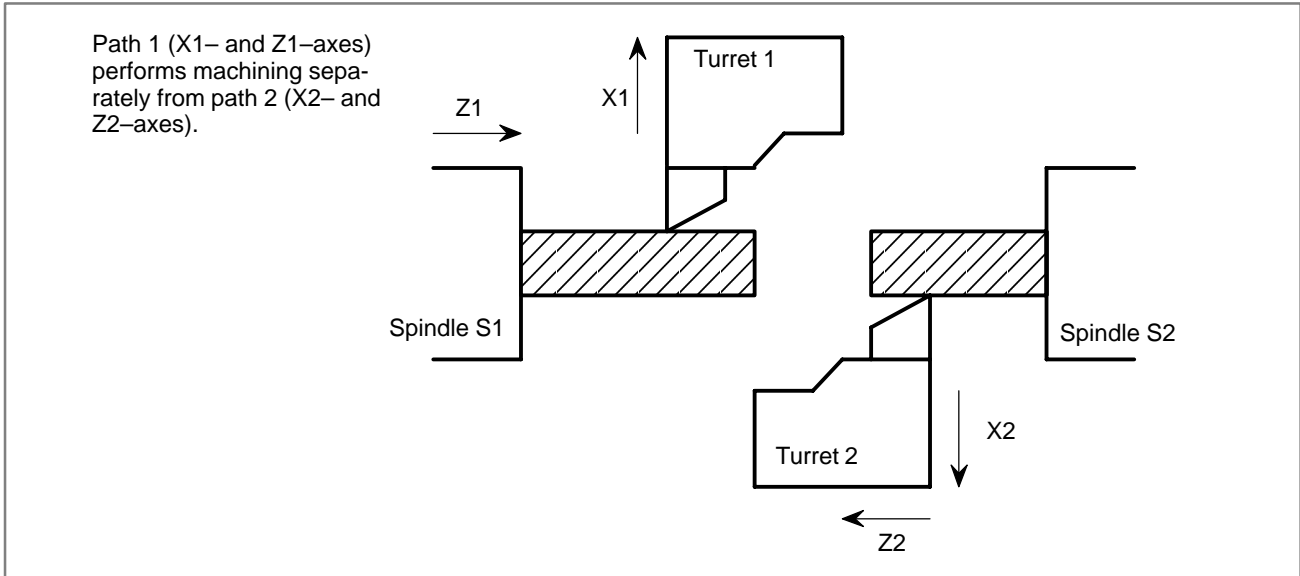

(b) Superimposed control for the Z1- and Z2-axes

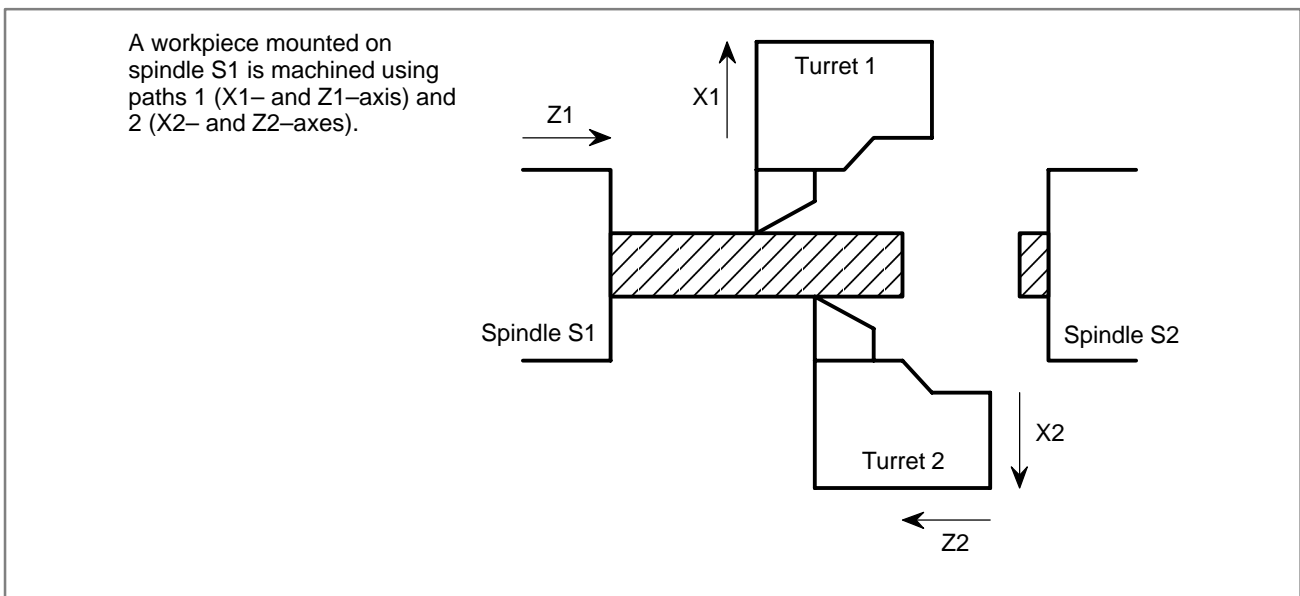

(2) Parameter setting

- To superimpose the move commands for the Z1-axis on the Z2-axis, set parameter No. 8186z of path 2 to "2".
- To apply mirror-imaged superimposed control (because the positive directions of the Z1- and Z2-axes do not match), set parameter No. 8162 (OMRz) of path 2 to "1".

- Set the feedrate along each Z-axis for superimposed control in parameter Nos. 8190z, 8191z, and 8193 of both paths. Each value to be set must be about half the one for independent control.
- Set the rapid traverse time constant for each Z-axis under superimposed control in parameter No. 8192z of both paths. Each value to be set must be 1 to 2 times the one for independent control.

(3)Signal setting

- Set signal G1190#1 OVLS2 to “1” when superimposed control begins for the Z1- and Z2-axes.
- Reset signal G1190#1 OVLS2 to “0” when superimposed control ends.
- Also reset G1190#1 OVLS2 to “0” when an emergency stop, NC reset, or alarm occurs.
- Keep signals other than G1190#1 OVLS2 reset to “0”.

(4)Sample program

<u>Path 1</u>	<u>Path 2</u>	
N1000	N2000	Machining under control independent of the other path
N1010 M300 ;	N2010 M300 ;	Waits for superimposed control to begin.
N1020 M55 ;		Begins superimposed control in which commands for the Z1-axis are superimposed on those for the Z2-axis.
N1030 M301 ;	N2030 M301 ;	Superimposed control has begun.
	N2040 T0414 ;	Selects a tool for superimposed control and sets the offset.
N1050 S1000 M3 ;		} Performs machining with turrets 1 and 2.
N1060 G0 X20. Z15. ;	N2060 G0 X18. Z120. ;	
N1070 G1 F0.5 W-8. ;	N2070 G1 F0.1 W5. ;	
N1080	N2080	
N1090 M302 ;	N2090 M302 ;	Waits for superimposed control to end.
N1100 M56 ;		Terminates superimposed control.
N1110 M303 ;	N2110 M303 ;	Superimposed control has ended.

N1120	N2120	Machining under control independent of the other path
-------------	-------------	---

WARNING

When using constant surface speed control, be careful about which path has the spindle command that is effective for spindle S1.

NOTE

The speed of spindle S1 (feedback pulses from the position coder) is specified for both paths 1 and 2.

Miscellaneous

- Synchronous control and composite control were described so far. In reality, however, it is possible to perform more than one set of synchronous control and/or composite control selectively or simultaneously. For this purpose, specify all necessary parameters and select which synchronous control or composite control to be performed using the appropriate signals. However, be careful not to perform more than one set of synchronous control or composite control for one axis at one time.
- Usually, it is possible to specify only one pair of axes for synchronous control and one pair for composite control. If it is necessary to specify more than one pair, specify so in a parameter with a program, using the programmable parameter input function (G10). This must be done when the related axes are not under synchronous or composite control.

(Example) Changing the parameter so that the Z2-axis is synchronized with the Y1-axis

(To set parameter No. 8180z of path 2 to “4”, run the following program in path 2.)

```

N0200 .....
N0210 G10 L50 ;           Begins parameter setting.
N0220 N8180 P2 R4 ;       Sets parameter No. 8180z
                           to “4”.
N0230 G11 ;               Terminates parameter
                           setting.
N0240 .....
```

The blocks with G10 to G11 must be run when the Z2- or Y1-axis is not under synchronous or composite control.

1.9.10 Troubleshooting

1. Synchronous, composite, or superimposed control cannot be started, but no alarm is issued.

(1) The synchronous or composite control option has not been specified.

⇒ The synchronous and composite control must be specified.

(2) The G0128, G0138, G0190, G1128, G1138, or G1190 signal has not been set.

⇒ Synchronous, composite, or superimposed control begins on the positive-going edge of the G0128, G0138, G0190, G1128, G1138, or G1190 signal. If synchronous, composite, or superimposed control ends because of a reset or alarm, merely releasing the reset or alarm cannot restart synchronous, composite, or superimposed control. It is also necessary to initiate the signal.

(3) The axis number of an axis to be subjected to synchronous, composite, or superimposed control has not been specified in a parameter.

⇒ To use synchronous control, specify the axis number of the target master axis in parameter No. 8180. To use composite control, specify the axis number of the target axis in parameter No. 8183 of path 2. To use superimposed control, specify the axis number of the target master axis in parameter No. 8186.

(4) Synchronous, composite, or superimposed control cannot be started when the NC unit is under one of the following conditions.

- Emergency stop
- Reset
- Servo alarm
- P/S000 alarm
- Alarm related to synchronous, composite, or superimposed control

In addition, synchronous, composite, or superimposed control cannot be started when the NC unit is under one of the following conditions.

- Servo-off
- Overtravel

2. The P/S225 alarm occurs when a signal for synchronous, composite, or superimposed control is initiated if:

(1) An attempt was made to perform synchronous, composite, or superimposed control for an axis that was already under synchronous, composite, or superimposed control.

⇒ It is impossible to place an axis under more than one combination of synchronous, composite, and/or superimposed control simultaneously. However, a synchronous master axis can be the master of more than one synchronous slave axis, and other slave axes can be added under the same synchronous control.

(2) The axis number specified in a parameter is greater than the number of controllable axes.

⇒ The axis number of a synchronous master axis, an axis under composite control, or the master axis under superimposed control in one path must not be greater than the number of controllable axes in the other path (or in the same path if synchronous control is performed within one path).

(3) An axis to be placed in synchronization is already moving.

⇒ When synchronous, composite, or superimposed control begins, the target axis must be at a stop. An axis being at a stop means that the speed that is effective after acceleration/deceleration is zero.

3. The P/S225 alarm occurs when synchronous, composite, or superimposed control ends if:

(1) An axis to be released from synchronization is moving.

⇒ When synchronous, composite, or superimposed control ends, the target axis must be at a stop. An axis being at a stop means that the speed that is effective after acceleration/deceleration is zero. When terminating synchronization, make sure that the axis moving signal F0102/F1102 is "0".

NOTE

Before the P/S225 alarm that occurs when synchronous, composite, or superimposed control is terminated can be reset, it is necessary to place the machine in an emergency stop state.

4. The P/S226 alarm occurs during synchronous or composite control if:

(1) A move command was issued to a synchronous slave axis.

⇒ A move command (either automatic or manual) cannot be used for a synchronous slave axis.

-
- (2) A move command was issued to an axis under composite control for which parameter MUMx (bit 7 of parameter No. 8162) is “1”.
⇒ No move command (either automatic or manual) can be issued to an axis under composite control for which parameter MUMx (bit 7 of parameter No. 8162) is “1”.
5. Servo alarm No. 407 occurs during synchronous control if:
- (1) There is an excessive difference in the positional deviation between the synchronous master and slave axes.
⇒ Alarm SV407 can occur only when a check is being made for synchronous error. This alarm occurs typically when there is a large difference in acceleration/deceleration constants or servo parameters between the synchronous master and slave axes or when the actual machine movement is incorrect for any reason (such as incorrect synchronization).
6. The machine position deviates during synchronous control if:
- (1) The acceleration/deceleration constants or servo parameters (such as loop gain) do not match between the master and slave axes.
⇒ During synchronous control, acceleration/deceleration and servo control are performed for master and slave axes separately. (Instead, move commands are placed in synchronization.) Acceleration/deceleration time constants or servo characteristics may vary between the master and slave axes. In such cases, the actual machine movement does not match between axes.
7. The amount of movement is incorrect during synchronous, composite, or superimposed control if:
- (1) The diameter/radius specification or inch/metric input setting does not match between the master and slave axes.
⇒ Synchronous, composite, superimposed control does not make conversion on diameter/radius or inch/metric input specifications between the master and slave axes. The least command input must match between the master and slave axes.

8. An axis does not move to a specified position after synchronous or composite control switching if:

(1) A move command was issued within two blocks after synchronous or composite control switching.

⇒ The coordinate system in the CNC must be re-set at synchronous or composite control switching. No move command can be issued to an axis subjected to synchronous or composite control during automatic operation within two (or three for tool-tip radius compensation) blocks (including the current one) after synchronous or composite control switching. However, this restriction does not apply when the current block is an M code that does not buffer the next block or when the target axis is a synchronous master axis.

9. Synchronous, composite, or superimposed control was terminated when the G0128, G0138, G0190, G1128, G1138, or G1190 did not drop if:

⇒ Synchronous, composite, or superimposed control is terminated automatically, if one of the following conditions occurs in either path.

- Emergency stop
- Reset
- Servo alarm
- P/S000 alarm
- Alarm related to synchronous, composite, or superimposed control

In addition, synchronous, composite, or superimposed control is terminated for all axes, if one of the following conditions occurs for any axis under synchronous, composite, or superimposed control.

- Servo-off
- Overtravel

1.10 B-AXIS CONTROL (T SERIES)

General

This function sets an axis (B-axis) independent of the basic controlled axes X_1 , Z_1 , X_2 , and Z_2 and allows drilling, boring, or other machining along the B-axis, in parallel with the operations for the basic controlled axes. The X_2 and Z_2 axes can be used in two-path control mode

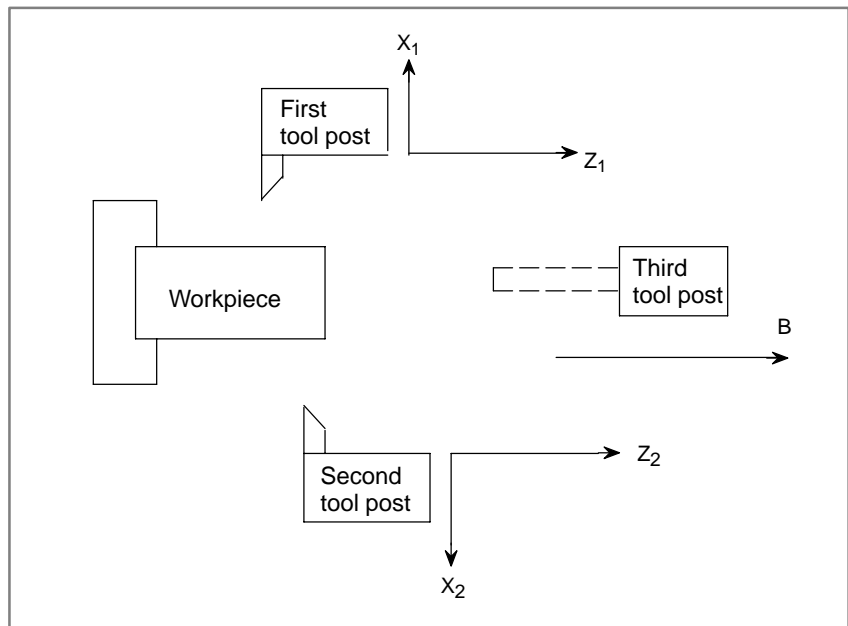

Format

- Registering operation programs

G101–G100 : Starts registering the first program.
G102–G100 : Starts registering the second program.
G103–G100 : Starts registering the third program.
G100 : Ends registering of the programs.

Three operations (programs) on the B-axis can be registered. (In two-path control mode, three programs can be registered for each tool post.) The B-axis operation program must be specified in the blocks between G101, G102, or G103 and G100, allowing it to be discriminated from the normal NC program.

The registered operation is started upon executing the corresponding M code, described below.

```
O1234 ;
  ⋮
      Normal NC program
G101 ; - ----- Starts registering of a B-axis
  ⋮                               operation program.
      B-axis operation program
G100 ; - ----- Ends registering of the B-axis
  ⋮                               operation program.
      Normal NC program
M30 ;
```

NOTE

- 1 In the block of G101, G102, G103, or G100, specify no other codes.
- 2 Use the PMC axis interface for the B-axis.

● **Command used to start the operation**

To start an operation, the miscellaneous functions (M**) specified in parameters 8251 to 8253 are used.

Parameter 8251:
M code used to start operation of the first program

Parameter 8252:
M code used to start operation of the second program

Parameter 8253:
M code used to start operation of the third program

```
O1234 ;
:
M** ; -           Starts executing the registered B-axis operation. In
:               subsequent blocks, the normal NC program and the
M30 ;           B-axis operation program are executed in parallel.
                (** is specified in parameters 8251 to 8253.)
```

Example

```
O1234 ;
G50 X100. Z200. ;
G101 ;           ① Starts registering of an
G00 B10. ;       operation program.
M03 ;           ② Blocks of the B-axis
G04 P2500 ;       operation program
G81 B20. R15. F500 ;
G28 ;
G100 ;           ③ Ends registering of the
G00 X80. Z50. ;   operation program.
G01 X45. F1000 ;
:
G00 X10. ;
M** ;           ④ Command used to start the
G01 Z30. F300 ;   programmed operation
:
M30 ;
```

① to ③ : Specify the B-axis operation program in blocks between G101, G102, or G103 and G100. The program is registered in program memory.

④ : Starts executing the B-axis operation registered with ① to ③ above. In subsequent blocks, the normal NC operation and the B-axis operation are executed in parallel. An M code of the miscellaneous function is used to start the B-axis operation. The M code, used to start the operation, is specified in parameters 8251 to 8253.

● **Single-motion operation**

G110 [operation command];

A single-motion operation for the B-axis can be specified and executed as shown above. Such an operation need not be registered as a special (first to third) program. Nor does it need to be by a special command, as described above.

Explanations

- **Specifying two-path control mode**

One of the following three two-path control modes can be selected:

- 1 B-axis control is executed for either tool post 1 or 2.
- 2 B-axis control is executed separately for tool posts 1 and 2.
- 3 Identical B-axis control is executed for tool posts 1 and 2.

The axis is selected by parameter 8250 setting for each tool post.

- **Codes that can be used in a B-axis operation program**

The following 13 G codes, and the M, S, and T codes of the miscellaneous functions, can be used in a B-axis operation program:

Code	Description
G00	Positioning (rapid traverse)
G01	Linear interpolation (cutting feed)
G04	Dwell
G28	Reference position return, automatic coordinate system setting
G80	Canned cycle, cancel
G81	Drilling cycle, spot drilling
G82	Drilling cycle, counterboring
G83	Peck drilling cycle
G84	Tapping cycle
G85	Boring cycle
G86	Boring cycle
G98	Feed per minute
G99	Feed per rotation
M**	Auxiliary function
S**	Auxiliary function
T**	Auxiliary function, tool offset

G28 (reference position return)

Unlike the normal G28 cycle, the G28 cycle for a B-axis operation does not include intermediate point processing. For example, the following cannot be specified:

G28 B99.9;

G80 to G86 (canned drilling cycle)

Of the canned drilling cycles supported by the CNC for machining centers, those cycles equivalent to G80 to G86 can be executed.

Data can be specified in the same way as for the CNC for machining centers, except for the following points:

1. The drilling position is not specified with X and Y.
2. The distance from point R to the bottom of the hole is specified with B.
3. All operations are executed in the initial level return mode.
4. The repetition count (K) cannot be specified.
5. In canned cycle mode, point R must be specified. (If point R is omitted, P/S alarm No. 5036 is output.)
6. The drilling clearance (d) for the G83 (peck drilling) cycle is specified with parameter 8258.

G98, G99 (feed per minute, feed per rotation)

The MDF bit (bit 2 of parameter 8241) specifies an initial continuous-state G code for G110, or the G code to start registration of the operation program (G101, G102, G103).

When the MDF bit is set to 0, the initial continuous-state code is G98.

When the MDF bit is set to 1, the initial continuous-state code is G99.

Example)

When MDF is set to 0

G110 B100. F1000. ; 1000 mm/min

G110 G99 B100. F1 ; 1 mm/rev

NOTE

In two-path control mode, the system uses the actual spindle speed, calculated from the feedback signal output by the position coder connected to the tool post to which the controlled axis belongs.

M, S, and T codes (auxiliary functions)

Based on the numeric value following the M, S, or T address, the binary code and strobe signal are sent to the PMC. The codes and signals for addresses M, S, and T are all output to an identical interface (auxiliary function code signals (EM 11g to EM 48g) and auxiliary function strobe signals (EMFg)) and can be used to control on or off of the PMC machine. For this purpose, the PMC axis control interface is used, which differs from that used for the miscellaneous functions for the normal NC program. The following M codes, used to control the spindle, are automatically output during the G84 (tapping) or G86 (boring) cycle:

M03: Forward spindle rotation

M04: Reverse spindle rotation

M05: Spindle stop

T** to T(** + 9), where ** is the number specified in parameter 8257, are used as the codes of the auxiliary functions to adjust the tool offset.

Example)

T50 to T59 if parameter 8257 is set to 50

NOTE

- 1 Range of commands of M, S, and T codes
- 2 An M, S, or T code must not be specified in a block containing another move command. The M, S, and T codes must not be specified in an identical block.
- 3 Usually, normal NC operation and B-axis operation are independent of each other. Synchronization between operations can be established by coordinating the miscellaneous functions of the normal NC program and B-axis operation program.

(Normal NC operation) (Registered B-axis operation)

:	:
M11 ;	G00 B111 ;
G01 X999 ;	G01 B222 ;
G28 Z777 ;	G28 ;
M50 ;	M50 ;
G00 X666 ;	G81 B444 R111 F222 ;
:	:

Upon receiving M50 of both the normal NC program and the B-axis program in the PMC ladder, the completion signals (FIN and EFING) are turned to a "1". G00 X666 of the normal NC program and G81 B444 R111 F222 of the B-axis program are executed simultaneously.

Custom macro

Custom macro variables (local variables, common variables, system variables #****) can be used in an operation program between G101, G102, or G103 and G100.

1. The value of the macro variable is calculated not from the data existing upon execution of the B-axis operation, but from the data existing at registration of the operation program.
2. An instruction that causes a branch to a location beyond the range of G101, G102, or G103 to G100 is processed without being checked.
3. In the two-path control mode, tool posts 1 and 2 use different macro variables.

- **Operation program**

When a new operation program is registered, the previous operation program is automatically deleted.

If an error is detected in an operation program to be registered, the program is initialized but is not registered.

- **Modal**

In the same way as a normal NC program, the B-axis operation program can use the following as modal data: modal G codes, F codes, and P, Q, and R codes in the canned cycle. These codes do not affect the modal information of the normal NC program. When a B-axis operation program is started (by G101, G102, or G103), the initial modal data is set for the program. It is not affected by the previous modal information.

Example)

```

:
G01 X10. F1000 ;           [1]
G101 (G102, G103) ;      [2]
B10. ;                    [3]
G01 B-10. F500 ;         [4]
G100 ;                    [5]
X-10. ;                   [6]
:

```

Irrespective of the modal information for normal operation (G01 specified in block), block [3] specifies G00 if the MDG bit (bit 1 of parameter 8241) is set to 0, or G01 if the MDG bit is set to 1. Block [6] causes movement of F1000, specified in block [1].

- **Operation start command**

The MST bit (bit 7 of parameter 8240) specifies the method used to start the B-axis operation as described below:

If the MST bit is set to 1, the B-axis operation is started when the M code to start the operation is executed.

If the MST bit is set to 0, the B-axis operation is started when the M code used to start the operation is executed and the PMC outputs the completion signal (FIN).

Up to five M codes for starting the programs can be stored. The programs corresponding to these M codes are executed in succession. (In two-path control mode, up to five codes can be stored for each tool post.)

Example)

```

When the first, second, and third programs are started by M40, M41,
and M42, respectively
O1234. ;
:
:
M40 ; M code for starting the first program
M41 ; M code for starting the second program
M42 ; M code for starting the third program
M40 ; M code for starting the first program
M41 ; M code for starting the second program
:
:
M30 ;

```

As M41 is specified while the program started by M40 is being executed, the second program is automatically started upon termination of the first program.

M42, M40, and M41, specified during execution of the first program, are stored such that the corresponding programs are executed in the same order as that in which the M codes are specified.

If six or more M codes for starting the programs are specified while a program is being executed, P/S alarm 5038 is output.

In two-path control mode, the M code specified for tool post 1 starts the B-axis program registered for tool post 1. The M code specified for tool post 2 starts the B-axis program registered for tool post 2.

- **Specifying absolute or incremental mode**

The amount of travel along the B-axis can be specified in either absolute or incremental mode. In absolute mode, the end point of travel along the B-axis is programmed. In incremental mode, the amount of travel along the B-axis is programmed directly.

The ABS bit (bit 6 of parameter 8240) is used to set absolute or incremental mode. When the ABS bit is set to 1, absolute mode is selected. When the ABS bit is set to 0, incremental mode is selected. The mode is specified with this parameter when the program is registered.

- **Specifying a tool offset**

The T** command shifts the end point of the specified B-axis travel, in either the positive or negative direction, by the amount specified with the B-axis offset screen. If this function is used to set the difference between the programmed tool position and actual tool position in machining, the program need not be modified to correct the tool position.

The value specified with parameter 8257 is assigned to the auxiliary function to cancel the offset. The subsequent nine numbers are assigned to the tool offset functions. These auxiliary function numbers are displayed on the B-axis offset screen. For details, see Operator's Manual.

- **Single-motion operation**

If a G110 block is specified, a single-motion operation along the B-axis can be specified and executed. In single-motion operation mode, a single block results in a single operation. The single-motion operation is executed immediately provided if it is specified before the B-axis operation is started. If the operation is specified while a registered program is being executed, the operation is executed once that program has terminated.

After the specified single-motion operation has been executed, the next block is executed.

```

:
G110 G01 B100. F200 ; Block for single-motion
                        operation along B-axis
G00 X100. Z20. ;
:

```

- **Program memory**

An operation program is registered in program memory as a series of different blocks of the move, dwell, auxiliary, and other functions. Program memory can hold a desired number of blocks, up to a maximum of 65535 blocks for each program. If the program memory contains no free space when an attempt is made to register a B-axis program, P/S alarm 5033 is output. Six blocks require 80 characters of program memory. A canned cycle (G81 to G86) is also registered as a series of blocks, such as travel and dwell.

The entire program memory is backed up by battery. The programs registered in program memory are thus retained even after the system power is turned off. After turning the system power on, the operation can be started simply by specifying the M code for starting the program.

Example)

```

:
G101 ;
G00 B10. ; ..... One block
G04 P1500 ; ..... One block
G81 B20. R50. F600 ; ..... Three blocks
G28 ; ..... One block
M15 ; ..... One block
G100 ;
: (Total 7 blocks)
    
```

• **Reset**

When the NC is reset by pressing the MDI reset key or by the issue of an external reset signal, reset and rewind signal, or emergency stop, B-axis control is also reset. The reset signal (ECLRg) can reset only B-axis control.

Limitations

• **Single-motion operation**

1. Only a single-motion operation can be specified with G110.

```

G110 G00 B100. ; ..... OK
G110 G28 ; ..... OK
G110 G81 B100. R150.0 F100 ; ... P/S alarm No.5034
            
```
2. A canned cycle (G81 to G86), and other operations containing multiple motions, cannot be specified with G110. If an inhibited operation is specified, P/S alarm No.5034 is output.
3. modal information specified with G110 does not affect the subsequent blocks. In the G110 block, the initial modal value specified at the start of the operation becomes valid, irrespective of the modal information specified the previous blocks.

Example)

When the MDG bit (bit 1 of parameter 8241) is set to 1 and the MDF bit (bit 2 of parameter 8241) is set to 1

```

G98 G00 X100. F1000 ; ..... (1)
G110 B200. F2.; ..... (2)
X200. ; ..... (3)
G01 X200. ; ..... (4)
    
```

Block (2) initiates cutting feed (G01) at 2.0 mm/rev (G99).

Block (3) initiates rapid traverse (G00).

Block (4) initiates cutting feed (G01) at 1000 mm/min (G98).

4. During tool-nose radius compensation, two or more G110 blocks cannot be specified in succession. If such blocks are specified in succession, P/S alarm No. 5041 is output. To specify two or more G110 blocks in succession for a B-axis operation, register the blocks as a program with G101, G102, or G103 and G100.

Examples

- Absolute or incremental mode

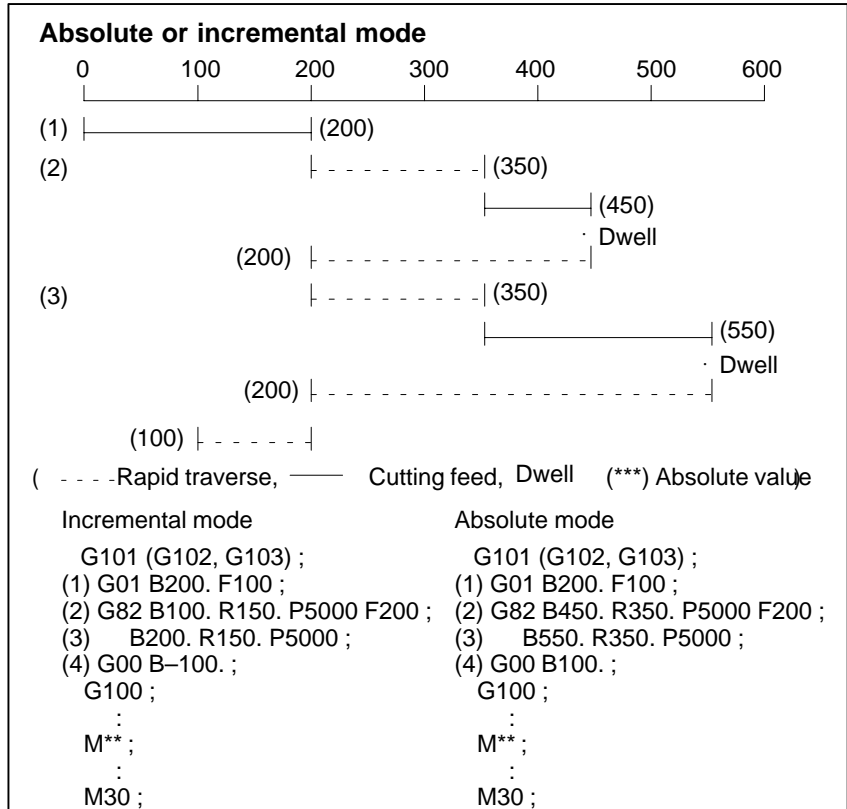

- Tool posts 1 and 2

If a single axis is used as the common B-axis of the two tool posts in two-path control, tool posts 1 and 2 share the B coordinate. For example, after program 1 for tool post 1 and program 2 for tool post 2 are executed in that order, the total travel along the B-axis appears to be +100.

```

<Program 1>
G101;
·
G00 B200.; (Absolute mode)
G100;
·
M30;

<Program 2>
G101;
G00 B300.; (Absolute mode)
·
G100;
·
M30;
    
```

● Tool offset

Example)
 When parameter 8257 is set to 50
 Auxiliary function used to cancel the offset: T50
 Auxiliary functions used to adjust a tool offset: T51 to T59

(Absolute mode)

(1) → (10)
 (2) → (20)
 (3) → (30)
 (4) → (25)
 (5) → (5)
 (6) → (0)

(Incremental mode)

(1) → (10)
 (2) → (20)
 (3) → (40)
 (4) → (35)
 (5) → (35)
 (6) → (30)

Program

```
G101 (G102, G103);
(1) G01 B10. F100;
(2) T51;
(3) G00 B20.;
(4) T52;
(5) B0.;
(6) T50;
G100;
:
M**;
```

Where the offset of T51 is 10.0 and the offset of T52 is 5.0

Parameter

	#7	#6	#5	#4	#3	#2	#1	#0
8240	MST	ABS	SOV	TEM	REF			

[Data type] Bit

REF Reference position return operation by G28:

0 : Always uses deceleration dogs in the same way as a manual reference position return operation.

1 : Uses deceleration dogs when a reference position has not yet been set, but is performed by rapid traverse when a reference position has already been set (in the same way as an ordinary G28 command).

TEM When an offset movement is made in a block containing a T code:

0 : Auxiliary function code signal and auxiliary function strobe signal are output before a movement along an axis.

1 : Auxiliary function code signal and auxiliary function strobe signal are output after a movement along an axis.

SOV A G110 block:

0 : Overlaps the next block.

1 : Does not overlap the next block.

ABS The B-axis command is:

0 : An incremental command.

1 : An absolute command.

MST When an M code for starting a movement along the B-axis is specified:

0 : Operation is started after a ready notice using the FIN signal is received.

1 : Operation is started without waiting for a ready notice.

	#7	#6	#5	#4	#3	#2	#1	#0
8241						MDF	MDG	FXC

[Data type] Bit

FXC In canned cycle G84:

0 : The spindle is rotated clockwise or counterclockwise after M05 is output.

1 : The spindle is rotated clockwise or counterclockwise without first outputting M05.

MDG The initial continuous-state value for starting B-axis operation command registration is:

0 : G00 mode (rapid traverse).

1 : G01 mode (cutting feed).

MDF The initial continuous-state value for starting B-axis operation command registration is:

0 : G98 (feed per minute).

1 : G99 (feed per rotation).

	#7	#6	#5	#4	#3	#2	#1	#0
8242								COF

[Data type] Bit

COF For tool post 1 and tool post 2 (under two-path control):

- 0 : A separate B-axis offset value is set.
- 1 : A common B-axis offset value is set.

8250	Axis number used for B-axis control
------	-------------------------------------

[Data type] Byte

[Valid data range] 1 to number of controlled axes (in one-path control)
 11 to ((number of controlled axes for tool post 1) + 10), or
 21 to ((number of controlled axes for tool post 2) + 20) (in two-path control)

This parameter sets which axis is to be used for B-axis control.

In one-path control, set the controlled axis number of a selected B-axis.

In two-path control, set the axis number, used for B-axis control on tool post 1, added to 10 when a tool post 1 axis is used.

Set an axis number, used for B-axis control on tool post 2, added to 20 when a tool post 2 axis is used.

Example of setting:

- (1) For one-path control
 - When the fourth axis is controlled as the B-axis, set 4 in this parameter. Furthermore, specify a DI/DO number to be used for the fourth axis in parameter No. 8010.
- (2) For two-path control
 - (a) When B-axis control is applied to tool post 1 only
 - When the fourth axis of tool post 1 is controlled as the B-axis, set 14 with this parameter of tool post 1. Furthermore, specify the DI/DO number to be used for the fourth axis with parameter No. 8010 for tool post 1.
 - (b) When B-axis control is applied to tool post 2 only
 - When the fourth axis on tool post 2 is controlled as the B-axis, set 24 with this parameter of tool post 2. Furthermore, specify a DI/DO number to be used for the fourth axis in parameter No. 8010 for tool post 2.
 - (c) When B-axis control is applied separately to tool post 1 and tool post 2
 - Make the settings described in (a) and (b) above.
 - (d) When B-axis control is simultaneously applied to both tool post 1 and tool post 2
 - When the fourth axis for tool post 1 is controlled as the common B-axis, set 14 with this parameter for both tool post 1 and tool post 2. Furthermore, specify a DI/DO number to be used for the fourth axis in parameter No. 8010 for tool post 1.

8251	M code (G101) for specifying the start of first program operation
8252	M code (G102) for specifying the start of second program operation
8253	M code (G103) for specifying the start of third program operation

[Data type] 2-word

[Valid data range] 6 to 99999999

These parameters set M codes for starting previously registered B-axis operation programs. M codes (such as M30, M98, and M99), already used for other purposes, cannot be set.

8257	T code number for tool offset cancellation
------	--

[Data type] Byte

[Valid data range] 0 to 90

This parameter sets a T code number for tool offset cancellation. When a T code from (setting + 1) to (setting + 9) is specified, tool offset is specified.

8258	Clearance, used in canned cycle G83, for the B-axis
------	---

[Data type] 2-word

[Valid data range] 0 to 99999999

[Unit of data]	Increment system	IS-B	IS-C	Unit
	Millimeter machine	0.001	0.0001	mm
	Inch machine	0.0001	0.00001	inch

This parameter sets the clearance used for peck drilling cycle G83.

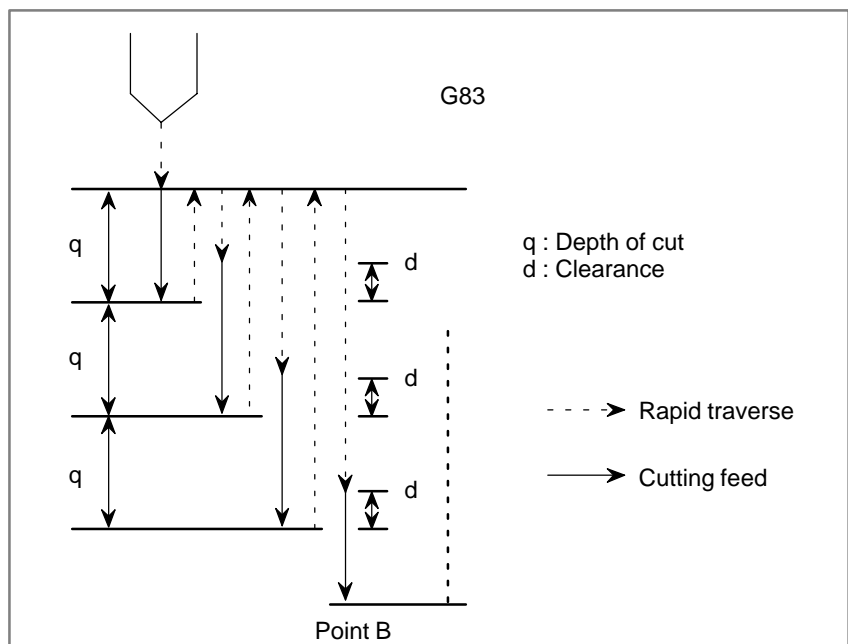

Alarm and message

Number	Message	Contents
5030	ILLEGAL COMMAND (G100)	The end command (G110) was specified before the registration start command (G101, G102, or G103) was specified for the B-axis.
5031	ILLEGAL COMMAND (G100, G102, G103)	While a registration start command (G101, G102, or G103) was being executed, another registration start command was specified for the B-axis.
5032	NEW PRG REGISTERED IN B-AXIS MOVE	While the machine was moving about the B-axis, an attempt was made to register another move command.
5033	NO PROG SPACE IN MEMORY B-AXIS	Commands for movement about the B-axis were not registered because of insufficient program memory.
5034	PLURAL COMMAND IN G110	Multiple movements were specified with the G110 code for the B-axis.
5035	NO FEEDRATE COMMANDED B-AXIS	A feedrate was not specified for cutting feed about the B-axis.
5036	ADDRESS R NOT DEFINED IN G81-G86	Point R was not specified for the canned cycle for the B-axis.
5037	ADDRESS Q NOT DEFINED IN G83	Depth of cut Q was not specified for the G83 code (peck drilling cycle). Alternatively, 0 was specified in Q for the B-axis.
5038	TOO MANY START M-CODE COMMAND	More than six M codes for starting movement about the B-axis were specified.
5039	START UNREGISTERED B-AXIS PROG	An attempt was made to execute a program for the B-axis which had not been registered.
5040	CAN NOT COMMANDED B-AXIS MOVE	The machine could not move about the B-axis because parameter No.8250 was incorrectly specified, or because the PMC axis system could not be used.
5041	CAN NOT COMMANDED G110 BLOCK	Blocks containing the G110 codes were successively specified in tool-tip radius compensation for the B-axis.

Caution

CAUTION

B-axis control uses the PMC axis control interface. This means that, before a B-axis command can be executed, the axis used as the B-axis must be placed under PMC axis control. To specify operations such as single block and feed hold, use PMC axis control signals. Referring to Section 15.1, set the PMC axis control parameters and signals.

Reference item

Series 16 <i>i</i> /18 <i>i</i> /160 <i>i</i> /180 <i>i</i> / 160 <i>is</i> /180 <i>is</i>	OPERATOR'S MANUAL (For Lathe) (B-63524EN)	III.11.2.7	Displaying the B-axis Operation State
		III.11.4.15	Setting and Displaying B-axis Tool Compensation
Series 21 <i>i</i> /210 <i>i</i> /210 <i>is</i>	OPERATOR'S MANUAL (For Lathe) (B-63604EN)	III.11.2.6	Displaying the B-axis Operation State
		III.11.4.15	Setting and Displaying B-axis Tool Compensation
CONNECTION MANUAL (This manual)		15.1	PMC Axis Control/PMC Axis Speed Control Function

1.11 ANGULAR AXIS CONTROL/ ARBITRARY ANGULAR AXIS CONTROL

General

When the angular axis makes an angle other than 90° with the perpendicular axis, the angular axis control function controls the distance traveled along each axis according to the inclination angle. For the ordinary angular axis control function, the X-axis is always used as the angular axis and the Z-axis is always used as the perpendicular axis. For angular axis control B, however, arbitrary axes can be specified as the angular and perpendicular axes, by specifying parameters accordingly. A program, when created, assumes that the angular axis and perpendicular axis intersect at right angles. However, the actual distance traveled is controlled according to an inclination angle.

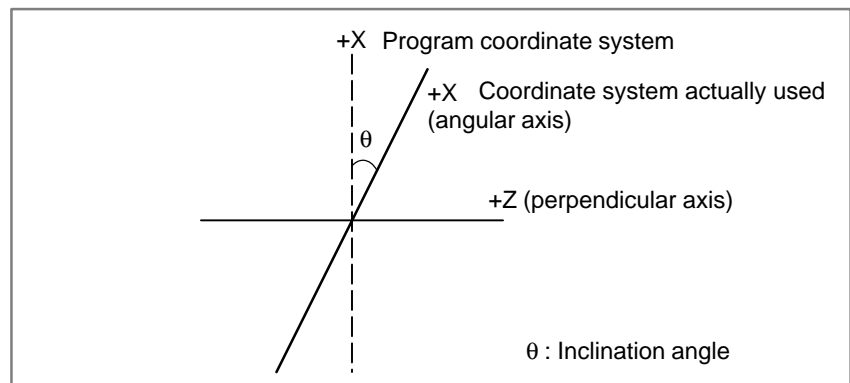

Explanations

When the angular axis is the X-axis and the perpendicular axis is the Z-axis, the amount of travel along each axis is controlled according to the formulas shown below.

The distance to be traveled along the X-axis is determined by the following formula :

$$X_a = \frac{X_p}{\cos \theta}$$

The distance traveled along the Z-axis is corrected by the inclination of the X-axis, and is determined by the following formula:

$$Z_a = Z_p - X_p \tan \theta$$

The speed component along the X-axis of feed rate is determined by the following formula:

$$F_a = \frac{F_p}{\cos \theta}$$

X_a, Z_a, F_a: Actual distance and speed

X_p, Z_p, F_p: Programmed distance and speed

- **Method of use**

The angular and perpendicular axes to which angular axis control is to be applied must be specified beforehand, using parameters (No. 8211 and 8212).

Parameter AAC (No. 8200#0) enables or disables the angular axis control function. If the function is enabled, the distance traveled along each axis is controlled according to an inclination angle (No. 8210).

Parameter AZR (No. 8200#2) enables angular axis manual reference point return only with a distance along the angular axis.

If perpendicular/angular axis control disable signal NOZAGC has been set to 1, the angular axis control function is enabled only for the angular axis. In that case, the move command for the angular axis is converted to angular coordinates. The perpendicular axis is not affected by the move command for the angular axis.
- **Absolute and relative position display**

An absolute and a relative position are indicated in the programmed Cartesian coordinate system.
- **Machine position display**

A machine position indication is provided in the machine coordinate system where an actual movement is taking place according to an inclination angle. However, when inch/metric conversion is performed, a position is indicated which incorporates inch/metric conversion applied to the results of the inclination angle operation.

Signal

Perpendicular/angular axis control disable signal NOZAGC

<G063#5>

[Classification] Input signal

[Function] Disables angular axis control for the perpendicular axis.

[Operation] When this signal is set to 1, the control unit behaves as follows:

- Converts an angular axis move command to angular coordinates. The perpendicular axis is, however, not affected by an angular axis move command.

Signal address

	#7	#6	#5	#4	#3	#2	#1	#0
G063			NOZAGC					

Parameter

	#7	#6	#5	#4	#3	#2	#1	#0
8200						AZR		AAC

[Data type] Bit

AAC 0 : Does not perform angular axis control.
1 : Performs angular axis control.

AZR 0 : The machine tool is moved along the Cartesian axis during manual reference position return along the angular axis under angular axis control.
1 : The machine tool performs manual reference position return along the angular axis under angular axis control.

8210	Inclination angle for angular axis control
------	--

[Data type] 2 words**[Unit of data]** 0.001 degree**[Valid data range]** 20000 to 60000

8211	Axis number of a angular axis subject to angular axis control
------	---

8212	Axis number of a Cartesian axis subject to angular axis control
------	---

[Data type] Word**[Unit of data]** Number**[Valid data range]** 1 to number of controlled axes

These parameters set the axis numbers of a angular axis and Cartesian axis subject to angular axis control.

Warning**WARNING**

- 1 After angular axis control parameter setting, be sure to perform manual reference point return operation.
- 2 If bit 2 (AZK) of parameter No. 8200 has been set to 0, such that manual reference position return along the angular axis also causes movement along the perpendicular axis, once manual reference position return has been performed along the angular axis, also perform manual reference position return along the perpendicular axis.
- 3 Once the tool has been moved along the angular axis with perpendicular/angular axis control disable signal NOZAGC set to 1, manual reference position return must be performed.
- 4 Before attempting to manually move the tool along both the angular and perpendicular axes simultaneously, set perpendicular/angular axis control disable signal NOZAGC to 1.

Note**NOTE**

1 For arbitrary angular axis control, if the same axis number has been specified in both parameters No. 8211 and 8212, or if a value outside the valid data range has been specified for either parameter, the angular and perpendicular axes will be as follows:

Angular axis: First axis (T series), Second axis (M series)

Perpendicular axis: Second axis (T series), First axis (T series)

2 If an inclination angle close to 0° or $\pm 90^\circ$ is set, an error can occur. A range from $\pm 20^\circ$ to $\pm 60^\circ$ should be used.

3 Before a perpendicular axis reference point return check (G27) can be made, angular axis reference point return operation must be completed.

Reference item

Series 16i/18i/160i/180i/ 160is/180is	OPERATOR'S MANUAL (For Machining Center) (B-63534EN)	II.20.5	Angular axis control/arbitrary angular axis control
	OPERATOR'S MANUAL (For Lathe) (B-63524EN)	II.19.6	Angular axis control/arbitrary angular axis control
Series 21i/210i/210is	OPERATOR'S MANUAL (For Lathe) (B-63604EN)	II.19.5	Angular axis control

1.12 CHOPPING FUNCTION (M SERIES)

General

When contour grinding is performed, the chopping function can be used to grind the side face of a workpiece. By means of this function, while the grinding axis (the axis with the grinding wheel) is being moved vertically, a contour program can be executed to initiate movement along other axes.

In addition, a servo delay compensation function is supported for chopping operations. When the grinding axis is moved vertically at high speed, a servo delay and acceleration/deceleration delay occur. These delays prevent the tool from actually reaching the specified position. The servo delay compensation function compensates for any displacement by increasing the feedrate. Thus, grinding can be performed almost up to the specified position.

There are two types of chopping functions: that specified by programming, and that activated by signal input. For details of the chopping function activated by signal input, refer to the manual provided by the machine tool builder.

Format

G81.1 Z__ Q__ R__ F__ ;

Z : Upper dead point

(For an axis other than the Z-axis, specify the axis address.)

Q : Distance between the upper dead point and lower dead point
(Specify the distance as an incremental value, relative to the upper dead point.)

R : Distance from the upper dead point to point R
(Specify the distance as an incremental value, relative to the upper dead point.)

F : Feedrate during chopping

G80; Cancels chopping

Explanations

● **Chopping activated by signal input**

Before chopping can be started, the chopping axis, reference position, upper dead point, lower dead point, and chopping feedrate must be set using the parameter screen (or the chopping screen).

Chopping is started once chopping start signal CHPST has been set to 1. This signal is ignored, however, during chopping axis movement.

When chopping hold signal *CHLD is set to 0 during chopping, the tool immediately moves to point R. Again setting the chopping hold signal to 1 restarts chopping.

Chopping can also be stopped by setting chopping start signal CHPST to 0, but only when chopping was started by using that signal.

Method of starting chopping	Method of stopping chopping	State
Signal CHPST = 1	Signal CHPST = 0	Stopped
	G80	Stopped
G81.1	Signal CHPST = 0	Not stopped
	G80	Stopped

NOTE

- 1 Switching to manual mode or suspending automatic operation, by means of feed hold, does not stop chopping.
- 2 In chopping mode, a chopping axis move command or canned cycle command cannot be specified.
- 3 If a G81.1 command is specified during chopping started by the signal, chopping is not stopped. If point R, the upper dead point, lower dead point, or chopping feedrate has been modified by using the G81.1 command, chopping is continued, but using the modified data.
- 4 The use of chopping start signal CHPST to start chopping is not enabled immediately after power-on; it is not enabled until the completion of manual reference position return.

● **Chopping feedrate (feedrate of movement to point R)**

From the start of chopping to point R, the tool moves at the rapid traverse rate (specified by parameter No. 1420).

The override function can be used for either the normal rapid traverse rate or chopping feedrate, one of which can be selected by setting ROV (bit 0 of parameter No. 8360).

When the chopping feedrate is overridden, settings between 110% and 150% are clamped to 100%.

● **Chopping feedrate (feedrate of movement from point R)**

Between point R, reached after the start of chopping, and the point where the chopping is canceled, the tool moves at the chopping feedrate (specified by parameter No. 8374).

The chopping feedrate is clamped to the maximum chopping feedrate (set with parameter No. 8375) if the specified feedrate is greater than the maximum chopping feedrate.

The feedrate can be overridden by 0% to 150% by applying the chopping feedrate override signal.

- **Setting chopping data**

Set the following chopping data:

- Chopping axis: Parameter No. 8370
- Reference point (point R): Parameter No. 8371
- Upper dead point: Parameter No. 8372
- Lower dead point: parameter No. 8373
- Chopping feedrate: Parameter No. 8374
- Maximum chopping feedrate: Parameter No. 8375

All data items other than the chopping axis and maximum chopping feedrate can be set on the chopping screen.

For details of how to set chopping data on the chopping screen, refer to the operator's manual.

- **Chopping after the upper dead point or lower dead point has been changed**

When the upper dead point or lower dead point is changed while chopping is being performed, the tool moves to the position specified by the old data. Then, chopping is continued using the new data.

While chopping is being performed, data can be changed only on the chopping screen. Changing the data on the parameter screen has no effect on the current chopping operation.

When movement according to the new data starts, the servo delay compensation function stops the servo delay compensation for the old data, and starts the servo delay compensation for the new data.

The following describes the operations performed after the data has been changed.

(1) When the upper dead point is changed during movement from the upper dead point to the lower dead point

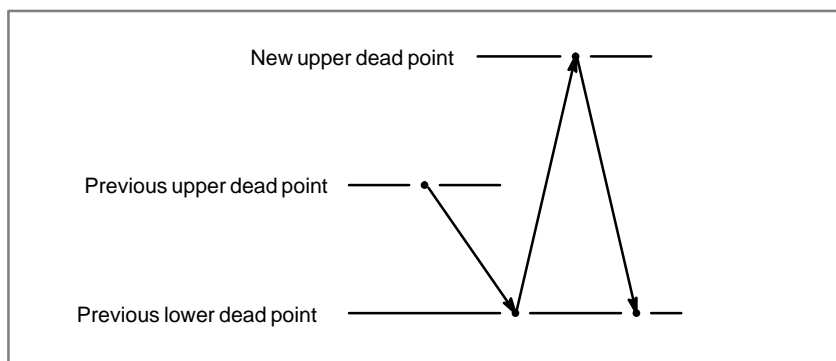

The tool first moves to the lower dead point, then to the new upper dead point.

Once movement to the lower dead point has been completed, the previous servo delay compensation is set to 0, and servo delay compensation is performed based on the new data.

(2) When the lower dead point is changed during movement from the upper dead point to the lower dead point

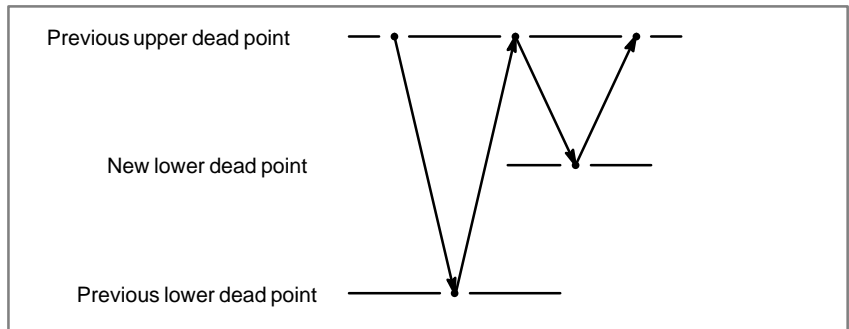

The tool first moves to the previous lower dead point, then to the upper dead point, and finally to the new lower dead point.

Once movement to the upper dead point has been completed, the previous servo delay compensation is set to 0, and servo delay compensation is performed based on the new data.

(3) When the upper dead point is changed during movement from the lower dead point to the upper dead point

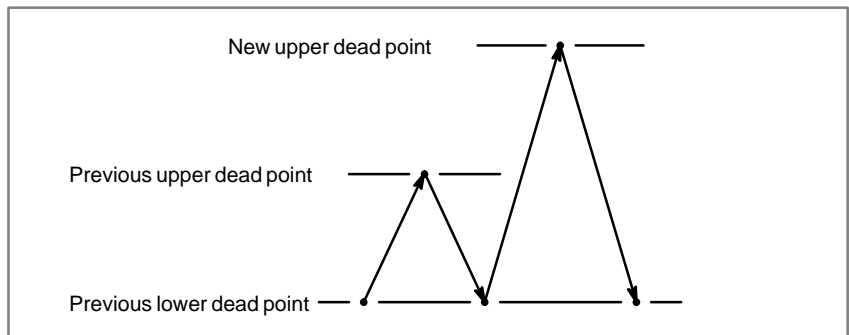

The tool first moves to the previous upper dead point, then to the lower dead point, and finally to the new upper dead point.

Once movement to the lower dead point has been completed, the previous servo delay compensation is set to 0, and servo delay compensation is performed based on the new data.

(4) When the lower dead point is changed during movement from the lower dead point to the upper dead point

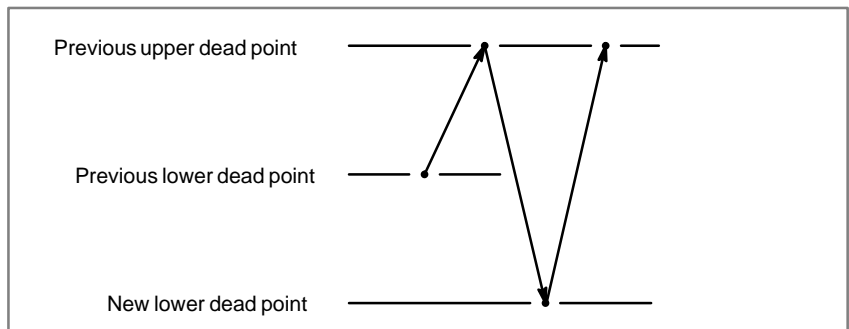

The tool first moves to the upper dead point, then to the new lower dead point.

Once movement to the upper dead point has been completed, the previous servo delay compensation is set to 0, and servo delay compensation is performed based on the new data.

• **Servo delay compensation function**

When high-speed chopping is performed with the grinding axis, a servo delay and acceleration/deceleration delay occur. These delays prevent the tool from actually reaching the specified position. The control unit measures the difference between the specified position and the actual tool position, and automatically compensates for the displacement of the tool. To compensate for this displacement, an amount of travel equal to the distance between the upper and lower dead points, plus an appropriate compensation amount, is specified. When a chopping command is specified, the feedrate is determined so that the chopping count per unit time equals the specified count. When the difference between the displacement of the tool from the upper dead point and the displacement of the tool from the lower dead point becomes smaller than the setting of parameter No. 8377, after the start of chopping, the control unit performs compensation.

When compensation is applied, the chopping axis moves beyond the specified upper dead point and lower dead point, and the chopping feedrate increases gradually.

When the difference between the actual machine position and the specified position becomes smaller than the effective area setting (parameter No. 1826), the control unit no longer applies compensation, allowing the tool to continue moving at its current feedrate.

A coefficient for the compensation amount for the displacement generated by the servo delay incurred by chopping and the delay incurred during acceleration/deceleration can be specified in parameter No. 8376.

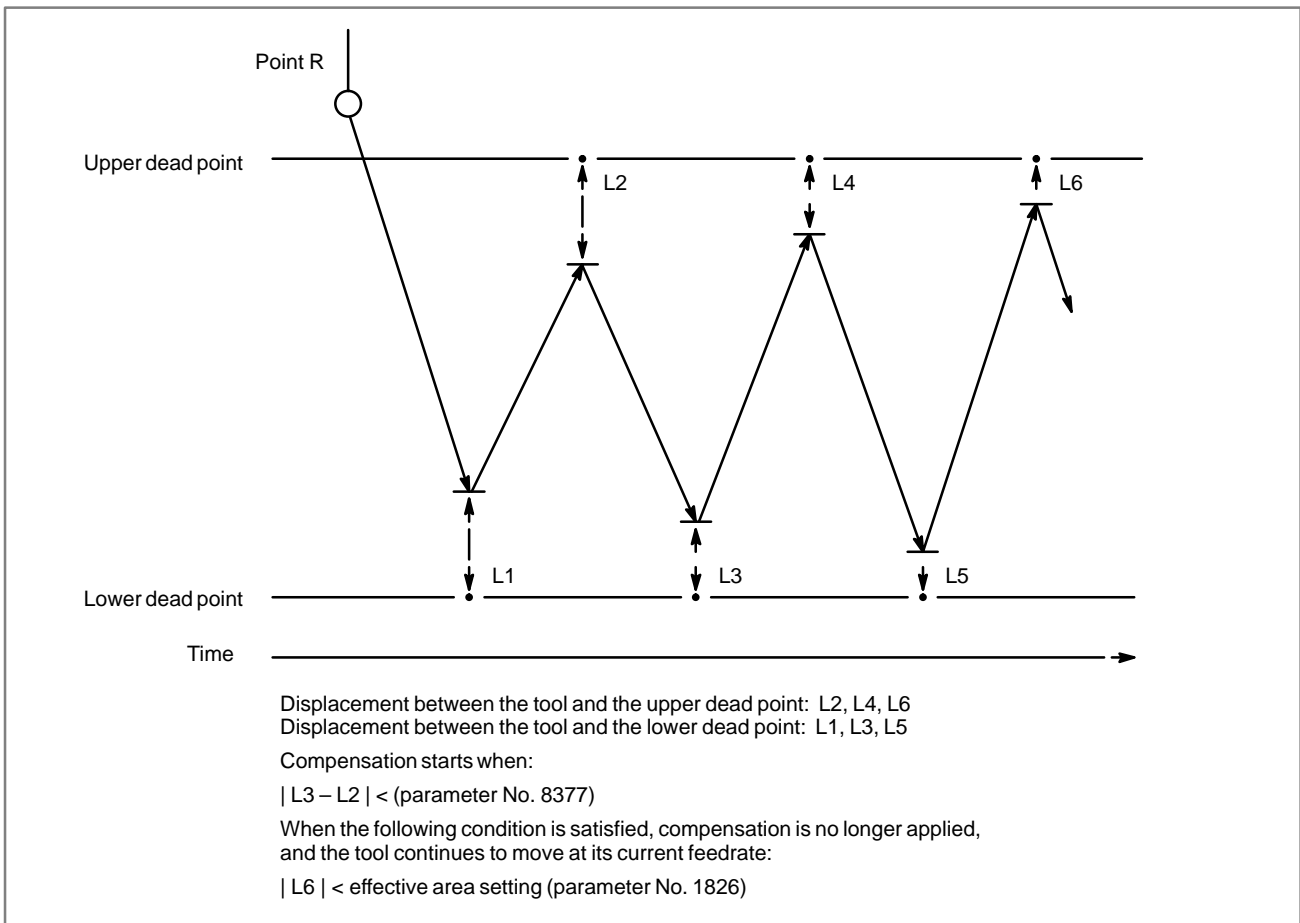

- **If servo delay compensation can cause the chopping speed to exceed the maximum allowable chopping feedrate:**

Servo delay compensation during a chopping operation can gradually increase the chopping speed. If the chopping speed is about to exceed the maximum allowable chopping feedrate, it is clamped to the maximum allowable chopping feedrate. In this case, the chopping axis may go beyond the bottom dead point. In servo delay compensation, the distance specified in a movement command is increased by a compensation amount that matches the distance yet to go before the top and bottom dead points are reached, and the chopping speed is also increased, so that the distance yet to go can be compensated for.

If the chopping speed is clamped to the maximum allowable chopping feedrate, a distance specified in the movement command is increased, but the clamped speed remains unchanged. For this reason, the chopping axis can go beyond the bottom dead point.

To solve this problem, use the CMX parameter (bit 0 of No. 8361) in order to stop clamping the chopping speed at the maximum allowable feedrate when the distance yet to go becomes smaller than a value specified in parameter No. 8378 (distance yet to go before the bottom dead point is reached), thereby allowing the speed to increase again, so that the bottom dead point will not be passed through.

In this case, servo delay compensation is carried out as follows:

- 1 Until the chopping speed reaches the maximum allowable chopping feedrate:
 - Compensation is carried out by increasing the speed and a distance specified in the movement command.
- 2 Until the chopping speed becomes lower than a value specified in parameter No. 8378 (distance yet to go) after it reaches the maximum allowable chopping feedrate:
 - Compensation is carried out by increasing only a distance specified in the movement command.
- 3 After the chopping speed reaches the maximum allowable chopping feedrate and becomes lower than a value specified in parameter No. 8378 (distance yet to go):
 - Compensation is carried out by increasing the speed and a distance specified in the movement command.

In this case, however, the final chopping speed can exceed the maximum allowable chopping feedrate because it is not clamped at the maximum allowable chopping feedrate.

[Parameter setting method]

- Parameter No. 8375 (maximum allowable chopping feedrate)
Set the parameter with a value smaller than the actual maximum allowable feedrate just in case the final chopping speed may exceed the maximum allowable feedrate.
- Parameter No. 8378
Set the parameter, using a value obtained with the following expression as a guideline.
If the bottom dead point can be passed through even when the value obtained with the following expression is set in the parameter, increase the value little by little until the dead point is no longer passed through.

Permissible error for restarting speed increase

[1 mm, 0.1 inch, 1 degree] =

parameter No. 8375

[1 mm/min, 0.1 inch/min, 1 degree/min] × 1/7500

- **Acceleration**
- **Mode switching during chopping**
- **Reset during chopping**
- **Stopping chopping**

Exponential acceleration/deceleration is used for chopping axis.

If the mode is changed during chopping, chopping does not stop. In manual mode, the chopping axis cannot be moved manually. It can, however, be moved manually by means of the handle interrupt.

When a reset is performed during chopping, the tool immediately moves to point R, after which chopping mode is canceled.

If an emergency stop or servo alarm occurs during chopping, chopping is canceled, and the tool stops immediately.

The following table lists the operations and commands that can be used to stop chopping, the positions at which chopping stops, and the operation performed after chopping stops:

Operation/command	Stop position	Operation after chopping stops
G80	Point R	Canceled
CHPST: "0"	The tool moves to the lower dead point, then to point R.	Canceled
*CHLD: "0"	Point R	Restart after *CHLD goes "1"
Reset	Point R	Canceled
Emergency stop	The tool stops immediately.	Canceled
Servo alarm	The tool stops immediately.	Canceled
P/S alarm	The tool moves to the lower dead point, then to point R.	Canceled
OT alarm	The tool moves from the upper or lower point to point R.	Canceled

- **Background editing**
- **Single block signal**

When an alarm of background editing or battery alarm is issued, the tool does not stop at point R.

Even when single block signal SBK is input during chopping, chopping continues.

Limitations

- **Workpiece coordinate system**
- **PMC axis**
- **Mirror image**

While chopping is being performed, do not change the workpiece coordinate system for the chopping axis.

When the chopping axis is selected as the PMC axis, chopping is not started.

While chopping is being performed, never attempt to apply the mirror image function about the chopping axis.

- **Move command during chopping** If a move command is specified for the chopping axis while chopping is being performed, a P/S 5050 alarm is issued.
- **Advanced preview control** This function does not support the advanced preview control function.
- **Program restart** When a program contains G codes for starting chopping (G81.1) and stopping chopping (G80), an attempt to restart that program results in a P/S 5050 alarm being output.

When a program that does not include the chopping axis is restarted during chopping, the coordinates and amount of travel set for the chopping axis are not affected after the restart of the program.

Examples

G90 G81.1 Z100. Q-25. R10. F3000 ;

- Perform rapid traverse to position the tool to Z110. (point R).
- Then, perform reciprocating movement along the Z-axis between Z100. (upper dead point) and Z75. (lower dead point) at 3000 mm/min. Chopping override is enabled.

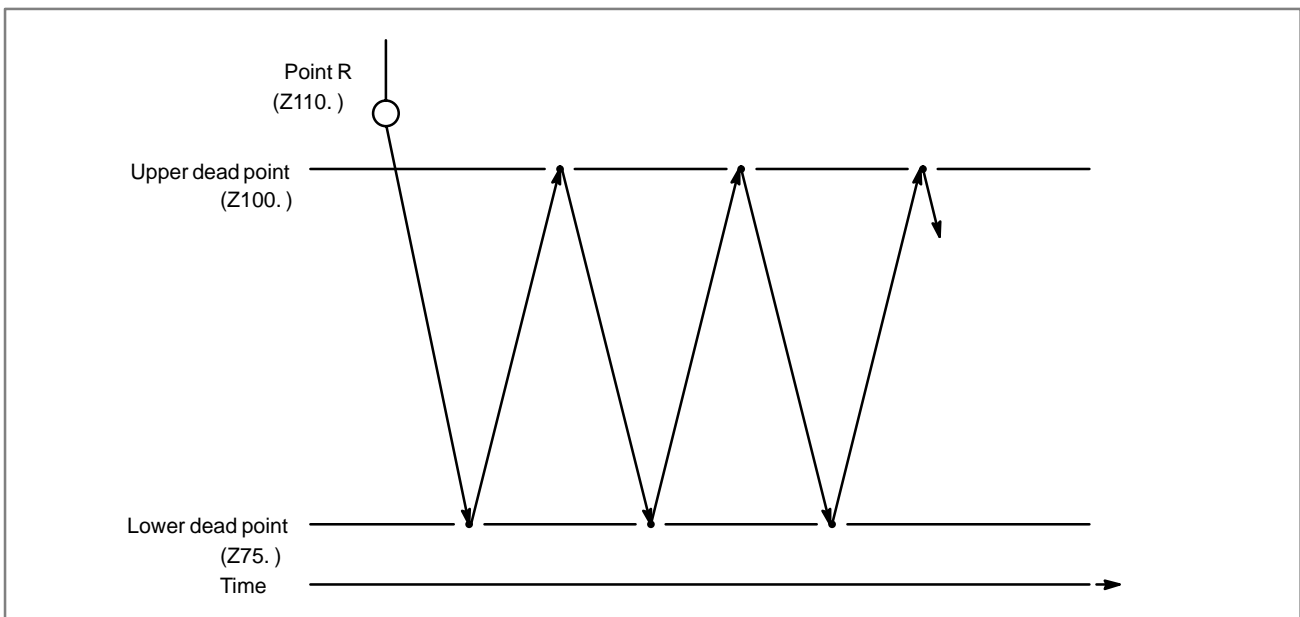

To cancel chopping, specify the following command:

G80 ;

- The tool stops at point R.

Signal

Chopping hold signal

*CHLD <G051#7>

[Classification] Input signal

[Function] Suspends chopping.

[Operation] Once this signal has been set to 0, the tool is moved from the current position to point R, thus suspending chopping. Again setting this signal to 1 while chopping is suspended causes chopping to be restarted.

Chopping start signal

CHPST <G051#6>

[Classification] Input signal

[Function] Starts and stops chopping.

[Operation] Setting this signal to 1 starts chopping.
Again setting this signal to 0 during chopping causes chopping to be stopped.

NOTE

- 1 If an attempt to start chopping using chopping start signal CHPST is ignored, set the signal to 0 then back to 1.
- 2 This signal is not enabled until the completion of manual reference position return.

**Chopping feedrate
override signals *CHP0
to *CHP8
<G051#0 to #3>**

[Classification] Input signal

[Function] Overrides the chopping feedrate.

[Operation] The actual feedrate during chopping becomes the specified feedrate multiplied by the override value specified with this signal. The following table lists the correspondence between the signal states and the override value:

*CHP8	*CHP4	*CHP2	*CHP0	Override value
0	0	0	0	150%
0	0	0	1	140%
0	0	1	0	130%
0	0	1	1	120%
0	1	0	0	110%
0	1	0	1	100%
0	1	1	0	90%
0	1	1	1	80%
1	0	0	0	70%
1	0	0	1	60%
1	0	1	0	50%
1	0	1	1	40%
1	1	0	0	30%
1	1	0	1	20%
1	1	1	0	10%
1	1	1	1	0%

**Chopping-in-progress
signal CHPMD <F039#2>**

[Classification] Output signal

[Function] Posts notification of chopping in progress.

[Operation] This signal is set to 1 in the following case:

- Upon chopping start signal CHPST being set to 1 to start chopping

This signal is set to 0 in the following cases:

- Upon chopping start signal CHPST being set to 0 to stop chopping
- Upon chopping being terminated by a reset.

Chopping cycle signal
CHPCYL <F039#3>

[Classification] Output signal

[Function] Posts notification of a chopping cycle being performed between the upper and lower dead points.

[Operation] This signal is set to 1 in the following case:

- Upon a chopping cycle being started between the upper and lower dead points

This signal is set to 0 in the following cases:

- Once chopping has been stopped
- When the tool is stopped at the upper or lower dead point
- Upon chopping hold signal *CHLD being set to 0

Signal address

	#7	#6	#5	#4	#3	#2	#1	#0
G051	*CHLD	CHPST			*CHP8	*CHP4	*CHP2	*CHP0
G039					CHPCYL	CHPMD		

Parameter

	#7	#6	#5	#4	#3	#2	#1	#0
8360	CHF					CVC		ROV

[Data type] Bit

ROV For the chopping function, a rapid traverse override for a section from the current position to the R point is determined as follows:
 0 : A chopping override is enabled.
 1 : An ordinary rapid traverse override is enabled.

CVC The feedrate along the chopping axis is changed:
 0 : At the upper or lower dead point immediately after the feedrate change command is issued.
 1 : At the upper dead point immediately after the feedrate change command is issued.

CHF On the chopping screen, the chopping speed can:
 0 : Be set.
 1 : Not be set.

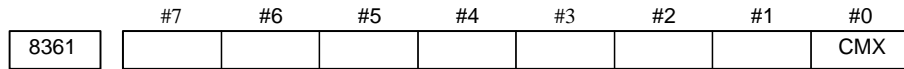

[Data type] Bit

CMX When the amount of shortage at the lower dead point becomes smaller than the value set in parameter No. 8378, clamping at the maximum chopping feedrate:

- 0 : Continues.
- 1 : Is not performed.

NOTE

Because clamping at the maximum chopping feedrate is not performed, the final chopping feedrate may exceed the maximum chopping feedrate.

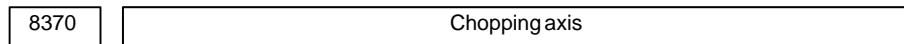

[Data type] Byte

[Valid data range] 1 to the number of controlled axes

This parameter specifies which servo axis the chopping axis corresponds to.

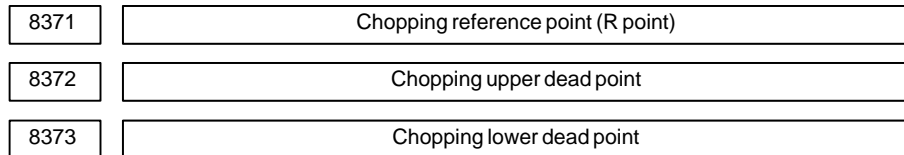

[Data type] 2-word

[Valid data range]

Increment system	IS-A	IS-B	IS-C	Unit
Metric machine	0.01	0.001	0.0001	mm
Inch machine	0.001	0.0001	0.00001	inch
Rotation axis	0.01	0.001	0.0001	deg

[Valid data range] -99999999 to 99999999

The data set in these parameters are absolute coordinates.

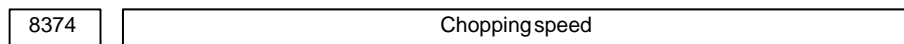

[Data type] 2-word

[Unit of data]

Increment system	Unit
Linear axis (metric input)	1.00 mm/min
Linear axis (inch input)	0.01 inch/min

Valid data range : For IS-A and -B, 240000 mm/min or 9600 inches/min
 For IS-C, 100000 mm/min or 4800 inches/min

8375	Maximum chopping feedrate
------	---------------------------

[Data type] 2-word

[Unit of data]

[Valid data range]

Increment system	Unit of data	Valid data range	
		IS-A, IS-B	IS-C
Metric machine	1 mm/min	30 to 240000	30 to 100000
Inch machine	0.1 inch/min	30 to 96000	30 to 48000
Rotation axis	1 deg/min	30 to 240000	30 to 100000

The chopping speed is clamped at a value specified in this parameter. When the parameter is 0, no chopping operation occurs.

8376	Chopping compensation scaling factor
------	--------------------------------------

[Data type] Byte

[Unit of data] %

[Valid data range] 0 to 100

This parameter specifies a scaling factor used to multiply the compensation value for a servo delay or acceleration/deceleration delay in an chopping operation. When this parameter is 0, servo delay compensation will not be applied.

8377	Compensation start tolerance
------	------------------------------

[Data type] Word

[Unit of data]

Increment system	IS-A	IS-B	IS-C	Unit
Metric machine	0.01	0.001	0.0001	mm
Inch machine	0.001	0.0001	0.00001	inch
Rotation axis	0.01	0.001	0.0001	deg

[Valid data range] 0 to 32767

Compensation is applied when the difference between an amount of shortage at the upper dead point and that at the lower dead point is less than the value specified in this parameter. In other words, this parameter is used to enable compensation after the chopping operation settles. When the parameter is 0, compensation will not be applied.

Alarm and message

Number	Message	Contents
5050	ILL-COMMAND IN CHOPPING MODE	When the chopping function is used, a move command was specified for a chopping axis in chopping mode (during reciprocation between a upper dead point and a lower dead point).

Reference item

Series 16 <i>i</i> /18 <i>i</i> /160 <i>i</i> /180 <i>i</i> / 160 <i>s</i> /180 <i>s</i>	OPERATOR'S MANUAL (For Machining Center) (B-63534EN)	II.20.6	Chopping function (G80, G81.1)
		III.11.4.13	Displaying and setting chop- ping data
Series 20 <i>i</i>	OPERATOR'S MANUAL (For Manual Milling Machine) (B-64204EN)	II.18.2	Chopping function (G80,G81.1)
		III.13.4.8	Displaying and setting chop- ping data

1.13 HOBBING FUNCTION (T SERIES)/ FUNCTION FOR HOBBING MACHINE (M SERIES)

General

Gears can be cut by turning the workpiece (C-axis) in sync with the rotation of the spindle (hob axis) connected to a hob.

Also, a helical gear can be cut by turning the workpiece (C-axis) in sync with the motion of the Z-axis (axial feed axis).

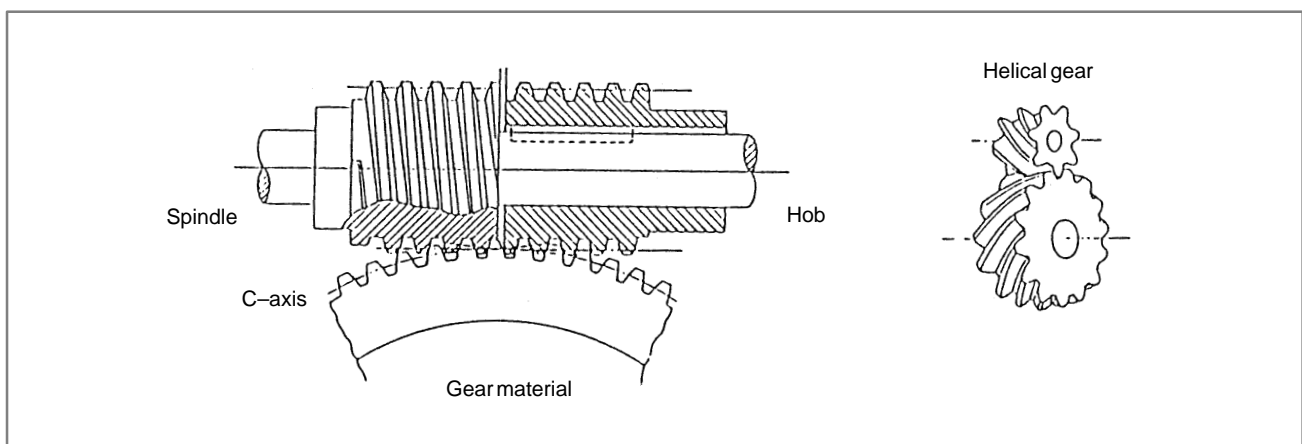

Format

• T series

G81.4 T _ L _ Q _ P _ ;

T : Number of teeth (specifiable range: 1 to 500)

L : Number of hob threads (specifiable range: 1 to 30 with a sign)

- The sign of L specifies the direction of rotation of the C-axis.
- If L is positive, the C-axis rotates in the positive direction (+).
- If L is negative, the C-axis rotates in the negative direction (-)

Q : Module or diametral pitch

For metric input, specify a module.

(Units = 0.00001 mm; specifiable range = 0.01 to 25.0 mm)

For inch input, specify a diametral pitch.

(Units = 0.00001 inch⁻¹; specifiable range = 0.01 to 250.0 inch⁻¹)

P : Gear helix angle

(Units = 0.0001 deg; specifiable range = -90.0 to +90.0 deg)

P and Q must be specified when a helical gear is to be cut.

G80.4 ; Cancels synchronization between the hob axis and C-axis.

- **M series**

<p>G81 T _ L _ Q _ P _ ;</p> <p>T : Number of teeth (specifiable range: 1 to 5000)</p> <p>L : Number of hob threads (specifiable range: 1 to 30 with a sign)</p> <ul style="list-style-type: none"> • The sign of L specifies the direction of rotation of the C-axis. • If L is positive, the C-axis rotates in the positive direction (+). • If L is negative, the C-axis rotates in the negative direction (-) <p>Q : Module or diametral pitch For metric input, specify a module. (Units = 0.00001 mm; specifiable range = 0.01 to 25.0 mm) For inch input, specify a diametral pitch. (Units = 0.00001 inch⁻¹; specifiable range = 0.01 to 250.0 inch⁻¹)</p> <p>P : Gear helix angle (Units = 0.0001 deg; specifiable range = -90.0 to +90.0 deg)</p> <p>P and Q must be specified when a helical gear is to be cut.</p> <p>G81 ; Cancels synchronization between the hob axis and C-axis.</p>

Explanations

- **G code list**

Code <T series>	Code <M series>	Group	Function
G80.4	G80	00	Cancels hobbing synchronization.
G81.4	G81		Starts hobbing synchronization.
G82.4	G82		Cancels the C-axis servo delay compensation.
G83.4	G83		Executes the C-axis servo delay compensation.
G84.4	G84		Stores the C-axis servo delay compensation.

- **Setting the C-axis**

Any axis can be set as the C-axis by setting the corresponding parameter appropriately (parameter No. 7710).

- **Maintaining the synchronization status**

The synchronization status is maintained provided:

- The interlock signal for the C-axis is turned on.
- The feed hold state exists.

- **Releasing the synchronization status**

Synchronization between the hob axis and C-axis can also be canceled when:

- The power is turned off.
- An emergency stop or servo alarm occurs.
- A reset (external reset signal, reset & rewind signal, or reset key on the MDI panel) is issued.

By setting bit 0 (HBR) of parameter No. 7700, the release of the synchronization status by a reset can be suppressed.

- **Helical gear compensation**

When a helical gear is to be cut, compensation for the C-axis, according to the amount of travel along the Z-axis (axial feed) and gear helix angle, is required.

Helical gear compensation is performed by adding compensation pulses, calculated using the following formula, to the C-axis which is synchronized with the hob axis:

$$\text{Compensation angle} = \frac{Z \times \sin(P)}{\pi \times R \times Q} \times 360 \text{ (For metric input)}$$

or

$$\text{Compensation angle} = \frac{Z \times Q \times \sin(P)}{\pi \times R} \times 360 \text{ (For inch input)}$$

where

Compensation angle: Signed absolute value (deg)

Z : Amount of travel along the Z-axis after the specification of G81.4/G81 (mm or inches)

Total amount of travel along the Z-axis in both automatic and manual modes

P : Signed gear helix angle (deg)

T : Number of teeth

Q : Module (mm) or diametral pitch (inch⁻¹)

The values of P, T, and Q must be programmed.

• **Direction of the helical gear compensation**

1 When bit 2 (HDR) of parameter No. 7700 = 1

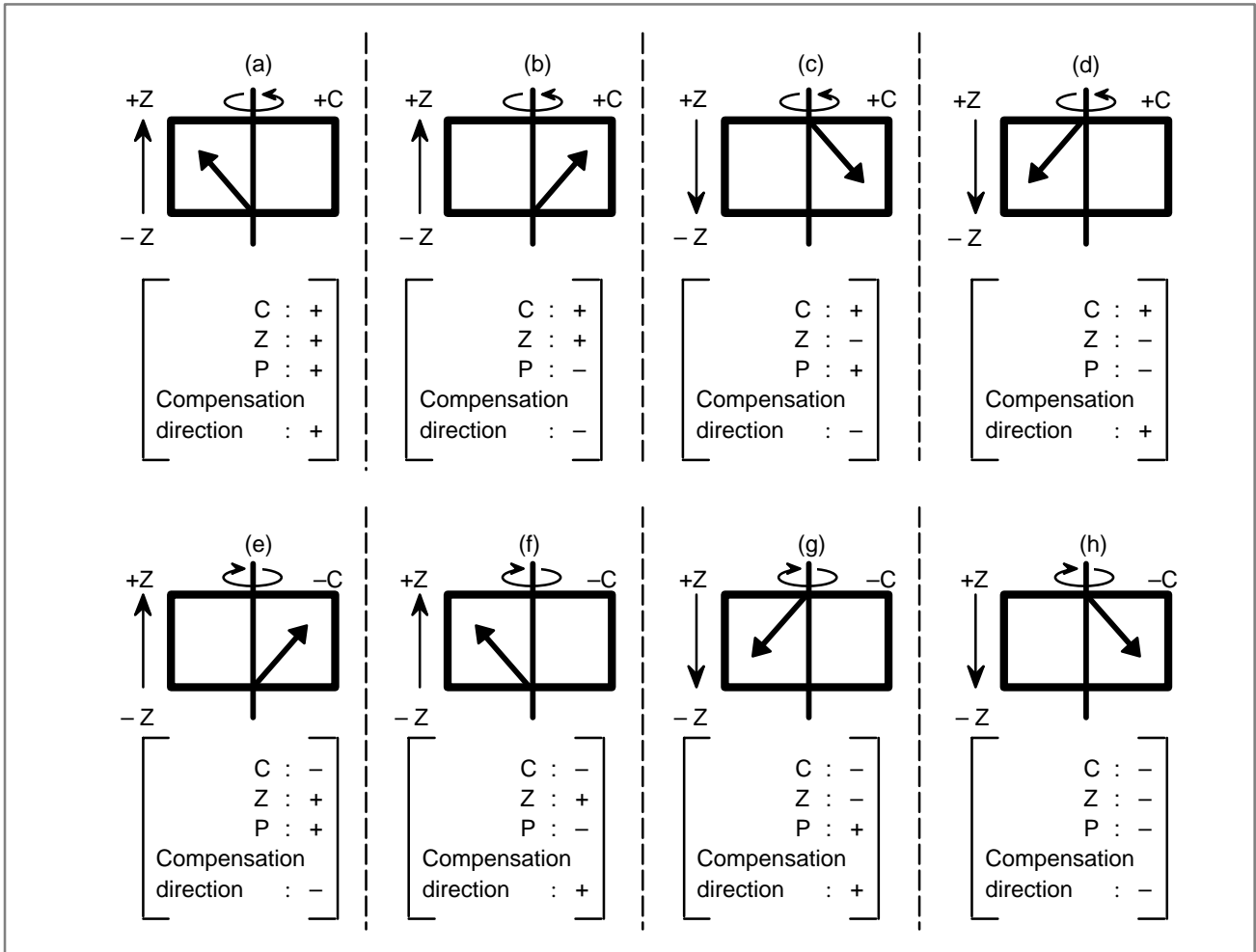

2 When bit 2 (HDR) of parameter No. 7700 = 0 (Items (a) to (d) are the same as for 1.)

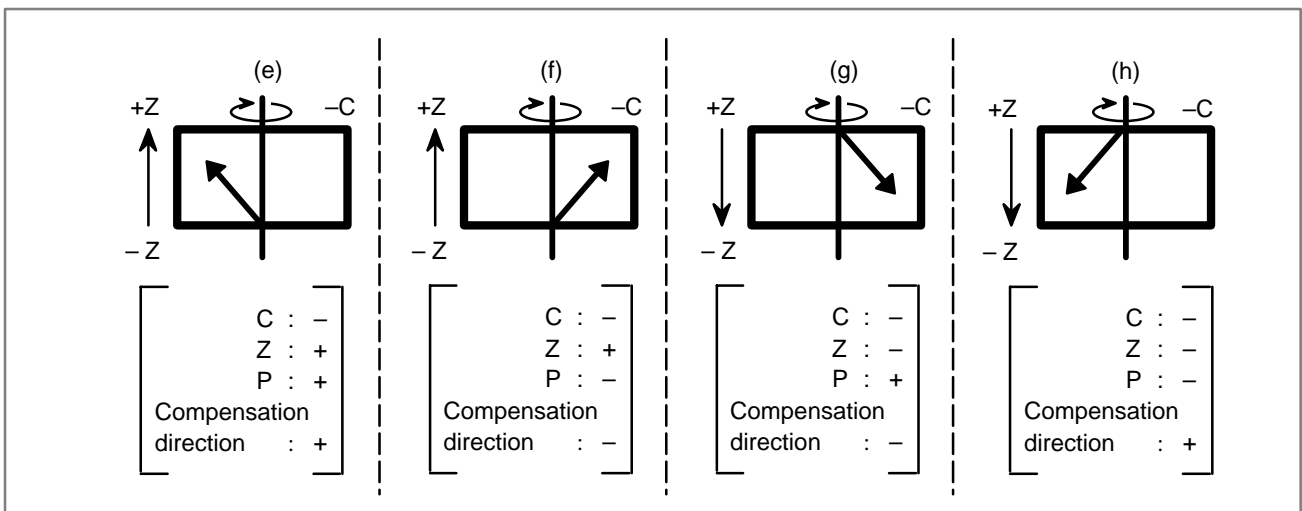

• **Setting the helical gear axial feed axis**

Any axis can be set as the Z-axis by setting the corresponding parameter appropriately (parameter No. 7709).

● C-axis servo delay compensation

The servo delay is proportional to the speed of the hob axis. Therefore, in a cycle where rough machining and finish machining are performed at different hob axis speeds, compensation for the servo delay is required.

The servo delay is calculated as follows:

$$E = \left\{ \left(\frac{F_c}{60} \right) \times \left(\frac{1}{K_s} + C * M + L \right) \text{Sup} \right\} \times N$$

where

E : C-axis servo delay compensation (deg)

F_c : C-axis speed when G83.4/G83 is specified (deg/min)

K_s : Servo loop gain (LPGIN of parameter No. 1825) (s⁻¹)

C : Delay incurred in the CNC (s)

M : Delay compensation magnification 1 in the CNC
(SVCMP1 of parameter No. 7715)

L : Delay incurred by smoothing, as specified by parameter No. 7701
(s)

Sup : Remaining pulse error caused by acceleration/deceleration (deg)

N : C-axis servo delay compensation magnification 2
(SVCMP2 of parameter No. 7714)

When the hob axis speed is changed, C-axis servo delay compensation is performed using either of the following two methods:

- Compensation is specified both before and after the speed is changed. Each time G83 is specified, compensation for the delay at that time is applied.
- Before the speed is changed, the servo delay is recorded. After the speed is changed, compensation for the difference between the recorded delay and that observed when the command is specified is performed.

The latter method, in which the compensation before speed change is recorded, can be used by setting bit 5 (DLY) of parameter No. 7701 to 1. This method, in comparison with that where the amount of compensation is not recorded, offers the advantage of increasing the processing speed.

- Method in which compensation for the delay when a command is specified is performed

G82.4/G82 : Cancels C-axis servo delay compensation.

G83.4/G83 : Executes C-axis servo delay compensation.

(Example)

G81(G81.4) T___ L___ ; ... Starts synchronization.

M03 S100 ; ... Rotates the hob axis.

G04 P2000 ; ... Causes the tool to dwell to assure constant hob axis rotation.

G01 G83.4 F___ ; ... Performs C-axis delay compensation.

G01 X___ F___ ;

.

.

G82(G82.4) ; ... Cancels C-axis servo delay.

S200 ; ... Changes the speed.

G04 P2000 ; ... Causes the tool to dwell to assure constant hob axis rotation.

G01 G83(G83.4) F___ ; ... Performs C-axis delay compensation.

- Method by which the delay before change is recorded
 - G82.4/G82 : Cancels C-axis servo delay compensation.
 - G83.4/G83 : Applies compensation for the difference between the C-axis servo delay, observed when G83.4/G83 is specified, and the delay recorded by G84.4/G84.
 - G84.4/G84 : Records the C-axis servo delay observed when G84.4/G84 is specified. (The recorded value remains as is until G81.4/G81 is specified or another G84 is specified.)

(Example)

```

G81(G81.4) T___ L___ ; .. Starts synchronization.
M03 S100 ; .. Rotates the hob axis.
G04 P2000 ; .. Causes the tool to dwell to assure
               constant hob axis rotation.

G84(84.4) ; .. Records the C-axis servo delay at
               the current speed.

G01 X___ F___ ;
.
.
.
S200 ; .. Changes the speed.
G04 P2000 ; .. Records the C-axis servo delay at
               the current speed.

G01 G83 F___ ; .. Applies C-axis delay
               compensation.

```

NOTE

- 1 Specify the G83.4/G83 block in G01 mode. Also, specify a feedrate using the F code.
- 2 Once G83.4/G83 has been specified, another G83.4/G83 command cannot be specified until compensation is canceled by specifying G82.4/G82, or until C-axis synchronization is canceled.
- 3 Specify G83.4/G83 once a constant hob axis rotation speed has been achieved.
- 4 In C-axis servo delay compensation (G83.4/G83), compensation is not applied to the integer part of the gear pitch. The compensation direction is opposite to that of the C-axis rotation.
- 5 During helical gear compensation, G00, G28, or G30 cannot be specified for the Z-axis or C-axis. If the prohibited specification is attempted, alarm 184 will be raised.
- 6 During helical gear compensation, travel on the Z-axis or C-axis cannot be made by manual rapid traverse. Travel by jog feed is performed.

- **C-axis synchronous shift**

- C-axis handle interrupt
During synchronization between the hob axis and C-axis, manual handle interrupt can be performed for the C-axis. The C-axis is shifted by the amount of the handle interrupt.
- Synchronous shift by programming
During synchronization between the hob axis and C-axis, the C-axis can be interrupted using G01. In this case, be careful not to exceed the maximum cutting speed.
Example: Hob shifting during synchronization
G01 Y___ C___ F___ ;

- **Manual setting of one-rotation signal**

When the rotation of the position coder is stopped, setting the one-rotation signal set signal MSPC to 1 causes the position of the one-rotation signal to shift in the CNC as if the one-rotation signal had been output with the position coder at the current position.

When the shift request is accepted, the one-rotation position setting completed signal MSPCF is output. According to this signal, the operator knows when the one-rotation signal position is shifted. The shift request is accepted if the C-axis is in sync-off state (G80.4/G80). The shift request is canceled when the synchronization cancel command (such as G80.4/G80 or a reset) is issued.

- **Retract function**

In both automatic and manual operation modes, setting the retract signal RTRCT to 1 (the rising edge is detected) enables retraction over the distance specified by parameter No. 7741, along the axis set by bit 0 (RTRx) of parameter No. 7730.

Upon the completion of retraction, the retract completed signal RTRCTF is output.

- The feedrate used for retracting is that specified using parameter No. 7740. Feedrate override is not supported for retracting.
- Feed hold is not supported for retraction.
- If the retract signal becomes 1 during automatic operation, retraction occurs, and automatic operation is discontinued.
- The retract completed signal becomes 0 when any retract axis is shifted.

The retract function is used, for instance, to retract the tool or workpiece when an error occurs in machining, so that the tool or workpiece will not be damaged.

Signal

Retract signal RTRCT<G066#4>

[Classification] Input signal

[Function] Causes retraction along an axis specified using bit 0 (RTR) of parameter No. 7730.

[Operation] When this signal becomes 1, the control unit behaves as follows:

- The control unit detects the positive-going edge of this signal, and can cause retraction along an axis specified using bit 0 (RTR) of parameter No. 7730 on that positive-going edge. The amount and speed of retraction are those specified in advance using parameter Nos. 7741 and 7740. Upon the completion of retraction, the retract completed signal RTRCTF becomes 1. The retract signal is usable for both automatic operation (such as MEM and MDI) and manual operation (such as HNDL and JOG) modes. If the retract signal is set to 1 during automatic operation, retraction is started, and automatic operation is discontinued.

Retract completed signal RTRCTF<F065#4>

[Classification] Output signal

[Function] Indicates when retraction is complete.

[Operation] The signal becomes 1 when:

- Retraction ends.

The signal becomes 0 when:

- Any movement along the axis occurs once retraction along that axis has been completed.

(1) Timing of turning on and off RTRCT and RTRCTF

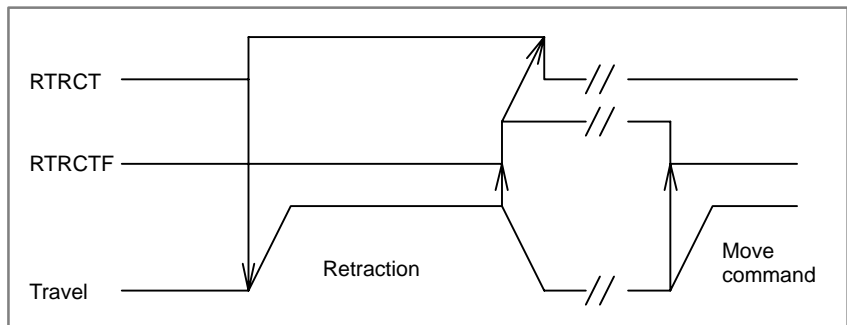

(2) Interruption of retraction by a reset

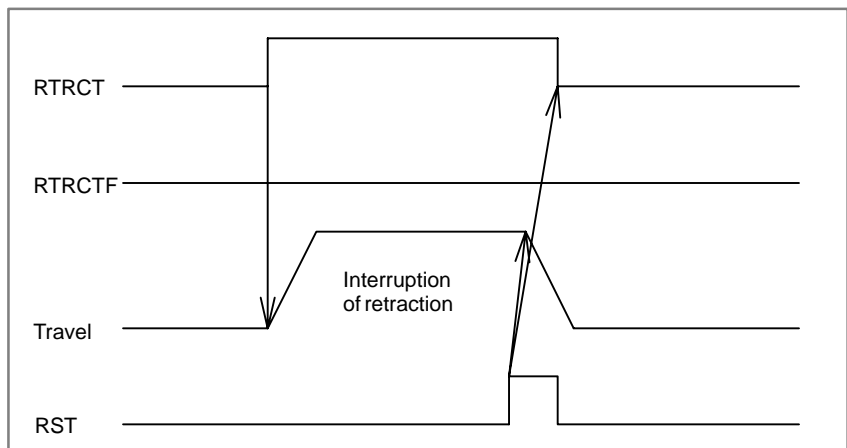

**One-rotation position
manual set signal
MSPC<G066#5>**

[Classification] Input signal

[Function] Shifts the one-rotation signal position of the position coder.

[Operation] When this signal becomes 1, the control unit behaves as follows:

- The position of the position coder when the signal becomes 1 is recorded as the one-rotation signal position in the CNC. In addition, the one-rotation signal setting completed signal MSPCF becomes 1 to indicate that the one-rotation signal position has been recorded. Once the one-rotation position manual set signal is issued, synchronization between the hob axis and C-axis is established according to the specified one-rotation signal position specified by G81.4/G81. This signal is ignored when:
 - The hob axis and C-axis are already in sync (G81.4/G81 mode).
 - The one-rotation signal setting completed signal MSPCF is already 1.

When bit 1 (CMS) of parameter No. 7700 is 0, issuing a synchronization cancel command (such as G80.4/G80 or a reset) cancels a specified one-rotation signal position. Once the one-rotation signal position is canceled, synchronization between the hob axis and C-axis is established according to a one-rotation signal from the position coder as specified by the G81.4/G81.

**One-rotation position
setting completed signal
MSPCF<F065#5>**

[Classification] Output signal

[Function] Indicates that the one-rotation signal position has been set up according to one-rotation position manual set signal MSPC.

[Operation] The signal becomes 1 when:

- The one-rotation signal position is set up according to one-rotation position manual set signal MSPC.

The signal becomes 0 when:

- The one-rotation signal position is canceled, that is, a synchronization cancel command (such as G80.4/G80 or a reset) is issued when bit 1 (CMS) of parameter No. 7700 is 0.

Sync-with-C-axis signal HOBSYN<F065#7>

[Classification] Output signal

[Function] Indicates that the hob axis is in sync with the C-axis.

[Operation] The signal is 1 when:

- The hob axis is in sync with the C-axis (during G81.4/G81 mode).

The signal is 0 when:

- The hob axis is not in sync with the C-axis (during G80.4/G80 mode).

Cancel-sync-with-C-axis signal HOBCAN <G066#2>

[Classification] Input signal

[Function] Cancels synchronization between the hob axis and C-axis.

[Operation] When the signal is 1, the control unit behaves as follows:

- The control unit cancels synchronization between the hob axis and C-axis (G81.4/G81 mode). The specified one-rotation position (MSPCF) varies with bit 1 (CMS) of parameter No. 7700.

Signal address

	#7	#6	#5	#4	#3	#2	#1	#0
G066			MSPC	RTRCT		HOBCAN		
F065	HOBSYN		MSPCF	RTRCTF				

Parameter

	#7	#6	#5	#4	#3	#2	#1	#0
1006								ROT _x

[Data type] Bit axis

ROT_x Specifies whether each axis is a linear or rotation axis.

0 : Linear axis

1 : Rotation axis

The C-axis (workpiece axis) must always be a rotation axis.

	#7	#6	#5	#4	#3	#2	#1	#0
3704		PCS						

[Data type] Bit axis

PCS To use the second, third, or fourth spindle as a hob axis, set 1 in this bit. If the feedback signals of position coders are swapped among paths under multipath control, set the same value in this parameter for all the paths.

NOTE

- 1 Just T series allows the second, third, or fourth spindle to be set as a hob axis.
- 2 This parameter is valid only when the optional multi-spindle control function is added.

	#7	#6	#5	#4	#3	#2	#1	#0
7700		DPS			MLT	HDR	CMS	HBR

[Data type] Bit

HBR Specifies whether to cancel synchronization between the C-axis and hob axis (G81.4/G81) when a reset occurs.

- 0 : Canceled.
- 1 : Not canceled.

CMS Specifies whether to cancel the manually set one-rotation signal position when a synchronization cancel command (such as G80.4/G80 or a reset) is issued.

- 0 : Canceled.
- 1 : Not canceled.

HDR Specifies the direction for compensating a helical gear. (This bit is usually set to 1.)

MLT Specifies the data unit for the C-axis servo delay compensation amount magnification (parameter No. 7714).

- 0 : 0.001
- 1 : 0.0001

DPS Specifies what is to be displayed as the actual spindle speed.

- 0 : Rotational speed of the hob axis
- 1 : Rotational speed of the spindle

	#7	#6	#5	#4	#3	#2	#1	#0
7701	HBD		DLY	JHD		SM3	SM2	SM1

[Data type] Bit

SM1, SM2, SM3 Specify how many times the hobbing machine is to sample feedback pulses from the position coder.

SM3	SM2	SM1	Number of times sampling is to be performed
0	0	0	4
0	0	1	1
0	1	0	2
0	1	1	16
1	0	0	32
1	1	0	4
1	1	1	4

JHD Specifies whether to enable C-axis jog and handle feed during synchronization between the C-axis and hob axis (G81.4/G81 mode).

0 : Disabled.

1 : Enabled.

DLY Specifies whether to enable C-axis servo delay compensation based on G84.

0 : Disabled.

1 : Enabled.

HBD Specifies whether to enable the specification of diametral pitch for inch input.

0 : Disabled.

1 : Enabled.

7709

Axis number of a helical gear axial feed axis

[Data type] Byte

[Valid data range] 1, 2, 3, ..., number of controlled axes

This parameter specifies the placing of the helical gear axial feed axis. If a value that falls outside the valid data range is specified, the helical gear axial feed axis is specified as the second axis (for T series) or third axis (for M series).

NOTE

The system power must be turned off then back on in order for this parameter setting to become effective.

7710

Axis number of a synchronous axis

NOTE

The system power must be turned off then back on in order for this parameter setting to become effective.

[Data type] Byte

[Valid data range] 1, 2, 3, ..., number of controlled axes

This parameter specifies the placing of an axis (workpiece) in sync with the hob axis (tool). If a value that falls outside the valid data range is specified, the synchronous axis is specified as the third axis (for T series) or fourth axis (for M series).

7711

Gear ratio of the hob axis to the position coder

[Data type] Byte

[Valid data range] 1 to 20

[Unit of data] 1

This parameter specifies the gear ratio of the hob axis to the position coder.

7712	Acceleration/deceleration time constant applied to the C-axis when it is in sync with the hob axis
------	--

[Data type] Word

[Unit of data] ms

[Valid data range] 0 to 4000

This parameter specifies an acceleration/deceleration (exponential acceleration/deceleration) time constant applied to the C-axis when it is in sync with the hob axis.

NOTE

In G01, G83.4/G83, and helical gear compensation, acceleration/deceleration is performed according to the acceleration/deceleration time constant for cutting feed and FL feedrate (parameter Nos. 1622 and 1623).

7713	Acceleration/deceleration FL feedrate applied to the C-axis when it is in sync with the hob axis
------	--

[Data type] Word

[Unit of data]

[Valid data range]

Unit of data	Valid data range	
	IS-B	IS-C
1 deg/min	6 to 15000	6 to 12000

This parameter specifies the FL feedrate for acceleration/deceleration (exponential acceleration/deceleration) applied to the C-axis when it is in sync with the hob axis.

7714	Magnification 2 for a G83-based C-axis servo delay compensation
------	---

[Data type] Word

[Unit of data] 0.0001/0.001

[Valid data range] 500 to 2000

This parameter specifies magnification 2 for a G83-based C-axis servo delay compensation.

7715	Magnification 1 for a G83-based C-axis servo delay compensation
------	---

[Data type] Word

[Unit of data] 0.0001/0.001

[Valid data range] 500 to 2000

This parameter specifies magnification 1 for a G83-based C-axis servo delay compensation.

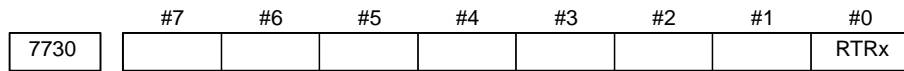

[Data type] Bit axis

RTRx Specifies whether to apply the retract function for each axis.
 0 : Not applied.
 1 : Applied.

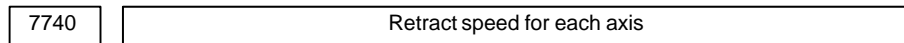

[Data type] Two-word axis

	[Unit of data]	Increment system	Unit of data	Valid data range	
[Valid data range]				IS-B	IS-C
		Metric machine	1 mm/min	30 to 240000	30 to 100000
		Inch machine	0.1 inch/min	30 to 96000	30 to 48000

This parameter specifies a retract speed for each axis.

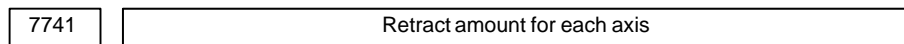

[Data type] Two-word axis

[Valid data range] -99999999 to 99999999

[Unit of data]	Increment system	Unit of data	
		IS-B	IS-C
	Metric input	0.001 mm	0.0001 mm
	Inch input	0.0001 inch	0.00001 inch

This parameter specifies a retract amount for each axis.

Caution

● **Retract function in general**

- Feedrate override cannot be applied to the retract speed.
- Interlock to the retract axis during retraction is enabled.
- Machine lock to the retract axis during retraction is enabled. The retraction ends in the machine lock state, and the retract completed signal is also output.
- During retraction, feed hold is disabled.
- The retract direction is always the travel direction of the machine, irrespective of whether mirror image (signal and setting) is enabled or disabled. (The updated absolute coordinates are subjected to the mirror image function.)
- If the retract function is executed in automatic operation, the automatic operation is halted when the retraction starts.
- Acceleration/deceleration of retraction is the same as that at the beginning of retraction.
- If a reset or emergency stop is made during retraction, the retraction is interrupted, and the retract completed signal is not set to 1.

- If a servo alarm or retract-axis overtravel alarm occurs during retraction, the retraction is interrupted. If this occurs, the retract completed signal does not go 1. An alarm other than the overtravel alarm or servo alarm will not cause the retraction to be interrupted.
 - Retraction cannot be interrupted by bringing the retract signal RTRCT to 0 after retraction starts.
 - While the retract completed signal RTRCTF is held to 1, the retract signal RTRCT is not accepted.
 - Performing retraction on the axis of the current movement under PMC axis control does not cancel the move command for the PMC axis. To perform retraction on the PMC axis of the current movement, set the retract signal RTRCT to 1 and cancel the PMC axis control by means of the PMC axis reset signal ECLRg.
- **Advanced preview**
 - In the advanced preview control mode, neither the hobbing function nor the retraction function can be used.
- **Setting the workpiece axis (C axis)**
 - The hobbing function and retraction function cannot be used for high-speed cycle machining or binary operation.
- **Synchronous, composite, and superimposed control**
 - While the workpiece axis (C-axis) is under synchronous, composite, or superimposed control, hobbing synchronization cannot be started. If the prohibited action is attempted, alarm 187 will be raised.
 - During hobbing synchronization, the workpiece axis (C-axis) cannot be brought under synchronous, composite, or superimposed control. If the prohibited action is attempted, alarm 225 will be raised.
- **Canned cycle**
 - When the hobbing machine function (M series) is enabled, no canned cycle for drilling can be used.
 - For the hobbing machine function (T series), a canned cycle is performed as follows:
 - (1) During hobbing synchronization, a canned cycle (G81 to G89) cannot be specified. If the prohibited specification is attempted, alarm 184 will be raised.
 - (2) In the canned cycle mode, the hobbing synchronization command G81.4 cannot be specified. If the prohibited specification is attempted, alarm 187 will be raised.
- **Thread cutting (T series)**
 - The retract function works even while the thread cutting command is effective. When the retract function is executed, the thread cutting immediately stops, starting retraction.
 - During hobbing synchronization, a thread cutting command (G32, G34, G92, etc.) cannot be specified. If the prohibited specification is attempted, alarm 184 will be raised.
 - In the thread cutting mode, the hobbing synchronization command G81.4 cannot be specified. If the prohibited specification is attempted, alarm 187 will be raised.
- **Manual operation**
 - During helical synchronization (if G81.4P_ is specified), the workpiece axis (C-axis) cannot cause jog feed on the two helical axes (Z-axes) simultaneously.
 - During helical synchronization (if G81.4P_ is specified), manual rapid traverse cannot be performed on the workpiece axis (C-axis) and helical axis (Z-axis). Jog feed is performed instead.

- **Setting the workpiece axis (C axis)**
 - Always set a rotation axis as the workpiece axis (C-axis). (Set RoTx (bit 0 of parameter No.1006) to 1.)

- **Gear ratio of spindle (hobbing axis) and position coder**
 - Set the parameter No. 7705#5 to 0, and set installation ratio with the spindle (hobbing axis) and position coder in parameter No. 7711.

- **Hob axis other than the first spindle (T series)**
 - When using a spindle other than the first spindle as the hob axis, set bit 6 of parameter No.3704 to 1. This parameter is valid only when the multi-spindle control function is added.

- **Feed per revolution during the hobbing synchronization**
 - During hobbing synchronization, feed per revolution is performed not on the spindle but on the workpiece axis (C-axis).

- **Rapid traverse during the hobbing synchronization (T series)**
 - During helical gear compensation, a rapid traverse command such as G00, G27, G28, or G30 cannot be specified for the Z-axis. If the prohibited specification is attempted, alarm 184 will be raised.
 - During hobbing synchronization, a rapid traverse command such as G00, G27, G28, or G30 cannot be specified for the workpiece axis (C-axis). If the prohibited specification is attempted, alarm 184 will be raised.

- **Hobbing synchronization with the multi-path system**
 - Hobbing synchronization can be performed only when the hob axis (spindle), workpiece axis (C-axis), and Z-axis are included in the same path.

Alarm and message

Number	Message	Description
010	IMPROPER G-CODE	1 Although the optional function for hobbing machine is not added, G80.4 to G84.4 or G80 to G84 is specified. 2 While bit 5 of parameter No.7701 is held to 0, G84.4 or G84 is specified.
181	FORMAT ERROR IN G81.4/G81 BLOCK	The G81.4/G81 block is not of the correct format. 1 R (number of teeth) has not been specified. 2 Data specified for R, L, Q, or P falls outside the valid data range.
182	G81.4/G81 NOT COMMANDED	G83.4/G83 (C-axis servo delay compensation) was specified when G81.4/G81-based synchronization had not been specified.
183	DUPLICATE G83.4/G83 (COMMANDS)	G83.4/G83-based C-axis servo delay compensation was requested again before the previous request had been canceled using G82.4/G82.

Number	Message	Description
184	ILLEGAL COMMAND IN G81.4/G81	An invalid command was issued during G81.4/G81-based synchronization. <ol style="list-style-type: none"> C-axis commands based on G00, G27, G28, G29, and G30 G20- or G21-based commands for switching between inch and metric inputs Thread cutting (G32/G33, G34, G35, G36, or G92) is specified. Canned cycle (G81 to G89) is specified. During helical gear compensation, a Z-axis command based on G00, G27, G28, G29, G30, etc. is specified.
185	RETURN TO REFERENCE POINT	G81.4/G81 was issued prior to returning to reference position but after the power was switched on or an emergency stop occurred.
186	PARAMETER SETTING ERROR	A value for a parameter related to G81.4/G81 is invalid. <ol style="list-style-type: none"> The C-axis has not been specified as a rotation axis (bit 0 (ROT) of parameter No. 1006). A value specified as the gear ratio of the hob axis to the position coder is invalid (parameter No. 7711). Note) These errors may be detected when G81.4/G81 is issued.
187	HOB COMMAND IS NOT ALLOWED (T series)	Error in the modal state when G81.4 or G81 is specified <ol style="list-style-type: none"> The canned cycle mode (G81 to G89) is set. The thread cutting mode is set. The C-axis is under synchronous, composite, or superimposed control.
225	SYNCHRONOUS/MIXED CONTROL ERROR (T series)	During hobbing synchronization, a command to bring the C-axis under synchronous, composite, or superimposed control is made.

Reference item

Series 16i/18i/160i/180i/ 160is/180is	OPERATOR'S MANUAL (For Machining Center) (B-63534EN)	II.20.7	Hobbing machine
	OPERATOR'S MANUAL (For Lathe) (B-63524EN)	II.19.8	Hobbing function

1.14 ELECTRIC GEAR BOX (M SERIES)

1.14.1 SIMPLE ELECTRIC GEAR BOX (G80, G81)

General

To machine (grind/cut) a gear, the rotation of the workpiece axis connected to a servo motor is synchronized with the rotation of the tool axis (grinding wheel/hob) connected to the spindle motor. To synchronize the tool axis with the workpiece axis, an electric gear box (EGB) function is used for direct control using a servo system. With the EGB function, the workpiece axis can trace tool axis speed variations without causing an error, thus machining gears with great precision.

- **Example control axis configuration**

The workpiece axis is set with parameter No. 7710.

Another servo axis is dedicated to the tool axis, which is connected to the spindle motor and for which the rotational position must be read directly by the servo system (this axis is called the EGB axis). It is necessary to assign these axes as odd and even servo axes in succession (parameter No. 1023). See Section 1.4.3 for an example showing how to specify the parameters for configuring the simplified electronic gearbox.

Format

G81 T _ L _ Q _ P _ ;	Starts synchronization.
S_ M03 (or M04) ;	Starts tool axis rotation.
M05 ;	Stops tool axis rotation.
G80 ;	Cancels synchronization.

T : Number of teeth (Specifiable range: 1 to 1000)

L : Number of hob threads
(Specifiable range: -200 to +200 with 0 excluded)

Q : Module or diametral pitch
Specify a module in the case of metric input.
(Unit: 0.00001 mm, Specifiable range: 0.01 to 25.0 mm)
Specify a diametral pitch in the case of inch input.
(Unit: 0.00001 inch⁻¹, Specifiable range: 0.01 to 25.0 inch⁻¹)

P : Gear helix angle
(Unit: 0.0001 deg, Specifiable range: -90.0 to 90.0 deg.)

* When specifying Q and P, the user can use a decimal point.

Explanations

• Synchronization control

1 Start of synchronization

When synchronization mode is set with G81, the synchronization switch of the EGB function is closed, and synchronization between the tool axis and workpiece axis starts. At this time, synchronization mode signal SYNMOD is turned on. During synchronization, the rotation of the tool axis and workpiece axis is controlled so that the relationship between T (number of teeth) and L (number of hob threads) can be maintained. Moreover, the synchronous relationship is maintained regardless of whether the operation is automatic or manual during synchronization.

G81 cannot be specified again during synchronization. Moreover, the specification of T, L, Q, and P cannot be modified during synchronization.

2 Start of tool axis rotation

When the rotation of the tool axis starts, the rotation of the workpiece starts so that the synchronous relationship specified in the G81 block can be maintained.

The rotation direction of the workpiece axis depends on the rotation direction of the tool axis. That is, when the rotation direction of the tool axis is positive, the rotation direction of the workpiece axis is also positive; when the rotation direction of the tool axis is negative, the rotation direction of the workpiece axis is also negative. However, by specifying a negative value for L, the rotation direction of the workpiece axis can be made opposite to the rotation direction of the tool axis.

During synchronization, the machine coordinates of the workpiece axis and EGB axis are updated as synchronous motion proceeds. On the other hand, a synchronous move command has no effect on the absolute and relative coordinates.

3 Termination of tool axis rotation

In synchronism with gradual stop of the tool axis, the workpiece axis is decelerated and stopped. By specifying the command below after the spindle stops, synchronization is canceled, and the EGB synchronization switch is opened. At this time, the synchronization mode signal (SYNMOD) is turned off.

4 Cancellation of synchronization

The position of the workpiece axis after travel during synchronization is reflected in the absolute coordinates when synchronization is canceled; from this point, absolute command programming is enabled for the workpiece axis. By setting bit 0 (HBR) of parameter No. 7700 to 0, synchronization can also be canceled upon reset.

* The synchronization mode is canceled by a servo alarm, PS000 alarm, or emergency stop.

- **Example timing for starting/terminating synchronization**

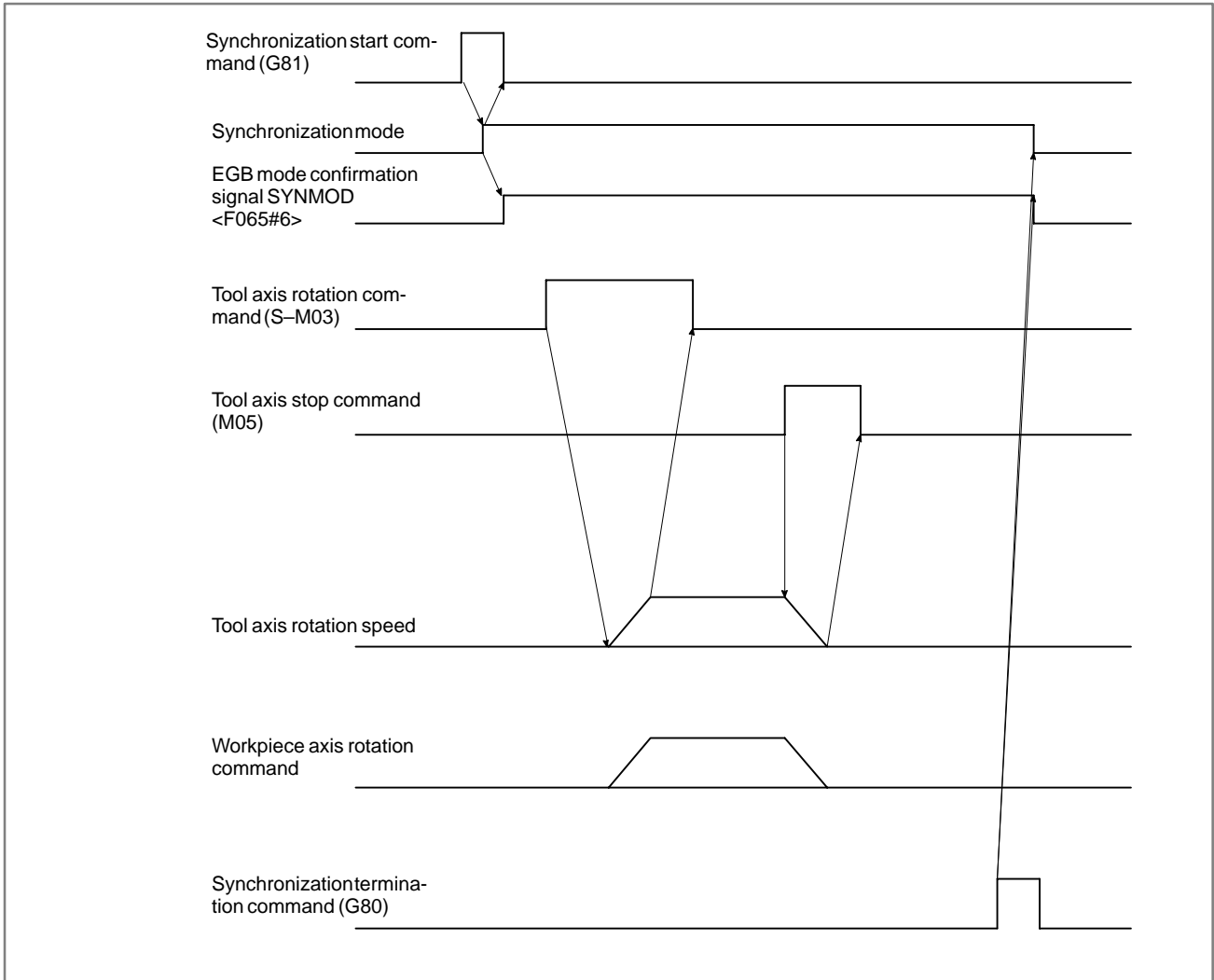

- **Helical gear compensation**

When a helical gear is to be produced, the compensation of workpiece axis rotation is needed according to the travel distance on the Z-axis (axial feed).

Helical gear compensation is performed by adding compensation pulses calculated from the formula below to the workpiece axis:

$$\text{Compensation angle} = \frac{Z \times \sin(P)}{\pi \times T \times Q} \times 360 \text{ (For metric input)}$$

or

$$\text{Compensation angle} = \frac{Z \times Q \times \sin(P)}{\pi \times T} \times 360 \text{ (For inch input)}$$

where

Compensation angle: Signed absolute value (deg)

Z: Amount of travel on the Z-axis after the specification of G81 (mm or inch)

P: Signed gear helix angle (deg)

T: Number of teeth

Q: Module (mm) or diametral pitch (inch⁻¹)

The values of P, T, and Q are to be programmed.

● **Direction of helical gear compensation**

1 When bit 2 (HDR) of parameter No. 7700 = 1

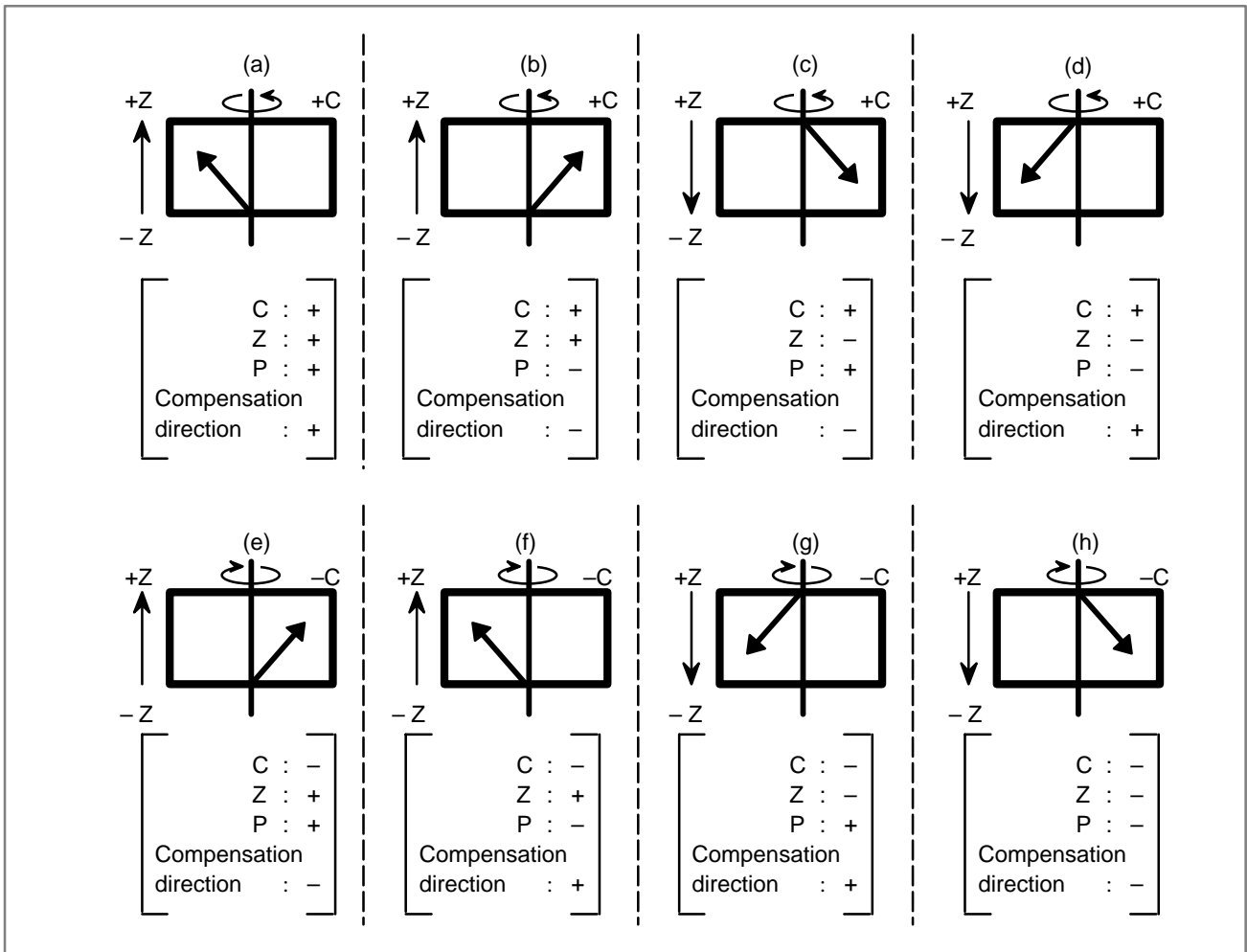

2 When bit 2 (HDR) of parameter No. 7700 = 0 (Items (a) to (d) are the same as for 1.)

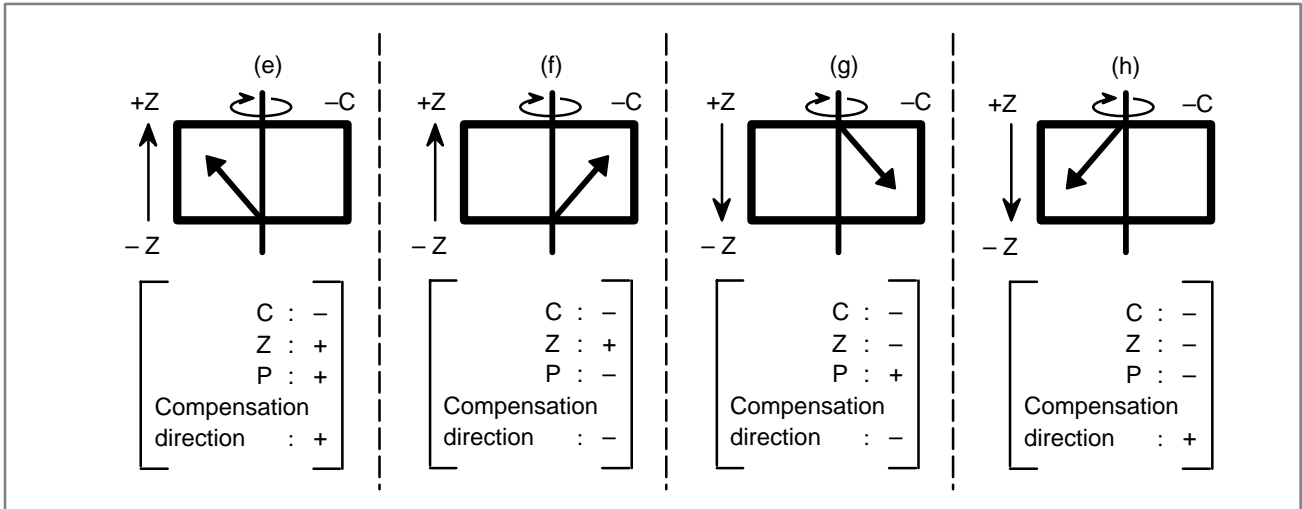

- **Coordinates in helical compensation**
- **Retraction**
- **Feedrate at retraction**
- **Retraction during automatic operation**
- **Synchronization coefficient**

In helical compensation, the machine coordinates and absolute coordinates of the workpiece axis are updated by the amount of helical compensation.

By turning on the retract signal RTRCT (on a rising edge) in automatic operation mode or manual operation mode, a retract movement can be made over the distance specified in parameter No. 7741 on the axis set in bit 0 (RTRx) of parameter No. 7730. Upon completion of retract operation, the retract completion signal RTRCTF is output.

For retract operation, the feedrate specified in parameter No. 7740 is used. During retract operation, the feedrate override capability is disabled.

When the retract signal is turned on in automatic operation, retract operation is performed, and automatic operation is stopped at the same time.

A synchronization coefficient is internally represented using a fraction (K2/K1) to eliminate an error. The formula below is used for calculation. (α, β : Number of detector pulses per rotation of the tool axis, and number of detector pulses per rotation of the workpiece axis (parameter Nos. 7772 and 7773), respectively)

$$\text{Synchronization coefficient} = \frac{K2}{K1} = \frac{L}{T} \times \frac{\beta}{\alpha}$$

In the formula above, K2/K1 is obtained by reducing the right side to lowest terms, but K1 and K2 must satisfy the following restriction:

$$\begin{matrix} -2147483648 & \leq & K2 & \leq & -2147483647 \\ & & 1 & \leq & K1 & \leq & 65535 \end{matrix}$$

When this restriction is not satisfied, the PS181 alarm is issued when G81 is specified.

- **Manual handle interrupt**

During synchronization, a manual handle interrupt can be used for the workpiece axis and other servo axes.

- **Move command during synchronization** During synchronization, a move command can be programmed for the workpiece axis and other servo axes. Note, however, that incremental command programming for cutting feed must be used to specify a workpiece axis move command.

Limitations

- **Feed hold during retraction** For retract movement, the feed hold capability is disabled and feedrate override is disabled.
- **Retraction when alarm is issued** This function does not include a retract function used when an alarm is issued.
- **Rapid traverse during synchronization** In synchronization mode, a cutting feedrate can be specified for the workpiece axis. Rapid traverse cannot be specified using G00.
- **Maximum speed** The maximum speeds of the tool axis and workpiece axis depend on the detectors used.
- **G code command during synchronization** During synchronization, G00, G28, G27, G29, G30, G53, G20, and G21 cannot be specified.
- **Drilling canned cycle** When this function is used, the drilling canned cycle cannot be used.

Examples

```

O1000 ;
N0010 M19 ;           Performs tool axis orientation.
N0020 G28 G91 C0 ;    Performs reference position return
                      operation of the workpiece axis.
N0030 G81 T20 L1 ;    Starts synchronization between the tool
                      axis and workpiece axis.
                      (The workpiece axis rotates 18° when
                      the tool axis makes one rotation.)
N0040 S300 M03 ;      Rotates the tool axis at 300 rpm.
N0050 G01 X____ F____ ; Makes a movement on the X-axis
                      (for cutting).
N0060 G01 Z____ F____ ; Makes a movement on the Z-axis
                      (for machining).
----- ;
----- ;
N0100 G01 X____ F____ ; Makes a movement on the X-axis
                      (for retraction).
N0110 M05 ;           Stops the tool axis.
N0120 G80 ;           Cancels synchronization between the
                      tool axis and workpiece axis.
N0130 M30 ;

```

Signal

Retract signal RTRCT <G066#4>

[Classification] Input signal

[Function] Performs retraction for the axis specified with a parameter.

[Operation] When this signal is set to 1, the control unit performs the following:

- Performs retraction on the axis specified with bit 0 (RTRx) of parameter No. 7730. The retract speed and amount of retraction are specified with parameter Nos. 7740 and 7741.
The retract signal is effective both in automatic operation mode and manual operation mode. Setting the retract signal to 1 during automatic operation suspends automatic operation and causes retraction to be performed.

Retract completion signal RTRCTF <F065#4>

[Classification] Output signal

[Function] Posts notification of the completion of retraction.

[Operation] This signal is set to 1 in the following case:

- Upon the completion of retraction

This signal is set to 0 in the following case:

- Upon the completion of retraction, when a move command follows immediately after

<p>NOTE</p> <p>The retract signal is not accepted while the retract completion signal is set to 1.</p>

EGB mode signal SYNMOD <F065#6>

[Classification] Output signal

[Function] Posts notification that synchronization using the EGB is in progress.

[Operation] This signal is set to 1 in the following case:

- While synchronization using the EGB is in progress

This signal is set to 0 in the following case:

- Once synchronization using the EGB has terminated

Signal address

	#7	#6	#5	#4	#3	#2	#1	#0
G066				RTRCT				
	#7	#6	#5	#4	#3	#2	#1	#0
F065		SYNMOD		RTRCTF				

Parameter

When setting the parameters for the simple electric gear box, note the following:

- (1) Set SYNMOD (bit 0 of parameter No. 2011) to 1 for the workpiece axis and EGB axis.
- (2) If FFALWY (bit 1 of parameter No. 2011) is set to 1, the values set in parameters No. 2068 and 2069 are used as the feed-forward factor and velocity loop feed-forward factor, respectively. For details, refer to "Feed-forward setting" in "Geometric error suppression function" in the FANUC AC SERVO MOTOR α i series Parameter Manual (B-65270EN) or FANUC AC SERVO MOTOR α series Parameter Manual (B-65150E).
- (3) Set the servo parameters for the EGB axis (No. 2000 and subsequent parameters) such that they do not conflict with the settings made for the workpiece axis.
- (4) Set the command multiplication (CMR) for the EGB axis (No. 1820) in the same way as for the 4th axis.
- (5) The following EGB axis parameters need not be set:
 - Reference counter capacity (No. 1821)
 - In-position width (No. 1826)
 - Excessive error while moving/stopped (No. 1828 and 1829)
 - Stored stroke limits (No. 1320 to 1327)
- (6) Set the flexible feed gear parameters (No. 2084 and No. 2085) for the EGB axis as follows:
No.2084=1 No.2085=1
- (7) Set the servo axis numbers in parameter No. 1023, using as many bits as the number of servo axes.

(Example)

When using the Y-axis as the EGB axis in a 4-axis configuration No. 1023 1st axis: 1 No. 1023 2nd axis: 4 No. 1023 3rd axis: 2 No. 1023 4th axis: 3	When using the 5th axis as the EGB axis in a 6-axis configuration No. 1023 1st axis: 1 No. 1023 2nd axis: 2 No. 1023 3rd axis: 5 No. 1023 4th axis: 3 No. 1023 5th axis: 4 No. 1023 6th axis: 6
---	---

(8) Parameter setting related to feed-forward control

- 1) To set the velocity loop to 1 msec, modify the motor type for the workpiece axis and EGB axis, thus reperforming automatic setting.
 Parameter No. 2020 = Motor number for 1 msec velocity loop
 Parameter No. 2000 bit 1 = 0
 Set the above, then turn the power off then back on again.

2) Re-set the parameters related to the EGB.

Parameter No. 2011 bit 0 = 1 (for both the workpiece and EGB axes)

Parameter No. 2011 bit 1 = 1 (for both the workpiece and EGB axes)(Note)

NOTE

Set this parameter when applying feed-forward control to rapid traverse also.

(3) Other parameters

Parameter No. 2003 bit 3 = 1 (P-I control)

Parameter No. 2005 bit 1 = 1 (feed-forward control enabled)

Parameter No. 2068 = 10000 (feed-forward factor)

(4) Suppressing load variation

Increase the value of parameter No. 2021 (within the range in which the motor does not oscillate).

Set this parameter to the value obtained from the following:

$256 \times (\text{machine load inertia}) / (\text{motor rotor inertia})$

For details of parameter setting, refer to "Feed-forward setting" in "Geometric error suppression function" in the FANUC AC SERVO MOTOR α i Series Parameter Manual (B-65270EN) or FANUC AC SERVO MOTOR α Series Parameter Manual (B-65150E).

	#7	#6	#5	#4	#3	#2	#1	#0
2011							FFALWY	SYNMOD

SYNMOD EGB synchronous control is:

0 : Not performed.

1 : Performed.

FFALWY The feed-forward function is:

0 : Enabled only for cutting feed.

1 : Always enabled.

NOTE

FFALWY must be set to 1.

	#7	#6	#5	#4	#3	#2	#1	#0
7700						HDR		HBR

[Data type] Bit

HBR 0 : Performing a reset cancels synchronous of the C-axis (G81).

1 : Performing a reset does not cancel synchronous of the C-axis (G81).

HDR Setting of the direction for compensating a helical gear (1 is usually specified.)

7709 Number of the axial feed axis for a helical gear

[Data type] Byte

[Valid range] 1 to the maximum number of controlled axes

This parameter sets the number of the axial feed axis for a helical gear. If the value out of the valid range is specified, 3 (the 3rd axis) is specified.

NOTE
After setting this parameter, the power must be turned off then on again in order to activate the new setting.

7710 Axis number of the slave axis for Spindle EGB control

[Data type] Byte

[Valid data range] 1 to the maximum number of controlled axes

This parameter sets the number of the slave axis for Spindle EGB control. If the value out of the valid range is specified, 4(the 4th axis) is specified. The slave axis number should be set larger than the master axis number (No.7771).

NOTE
After setting this parameter, the power must be turned off then on again.

	#7	#6	#5	#4	#3	#2	#1	#0
7730								RTRx

[Data type] Bit axis

RTRx Specifies whether the retraction function is effective for each axis.
0 : Retraction is disabled.
1 : Retraction is enabled.

7740 Feedrate during retraction for each axis

[Data type] 2-word axis

[Unit of data and valid range]

Increment system	Unit of data	Valid range	
		IS-B	IS-C
Millimeter machine	1 mm/min	30 to 240000	30 to 100000
Inch machine	0.1 inch/min	30 to 96000	30 to 48000

This parameter sets the feedrate during retraction for each axis.

7741	Retracted distance for each axis
------	----------------------------------

[Data type] 2-word axis

[Valid range] -99999999 to 99999999

Unit of data	Valid range	
	IS-B	IS-C
Millimeter input	0.001 mm	0.0001 mm
Inch input	0.0001 inch	0.00001 inch

This parameter sets the retracted distance for each axis.

7771	Number of EGB axis
------	--------------------

NOTE

After setting this parameter, turn off the power. Then, turn the power back on to enable the setting.

[Data type] Byte

[Valid data range] 1 to the number of controlled axes

This parameter specifies the number of the EGB axis.

NOTE

- 1 You cannot specify four because the fourth axis is used as the workpiece axis.
- 2 For a machine using the inch increment system, linear axes cannot be used as the EGB axis.

7772	Number of position detector pulses per rotation about tool axis
------	---

[Data type] 2-word

[Data unit] Detection unit

[Valid data range] 1 to 99999999

This parameter specifies the number of pulses per rotation about the tool axis (on the spindle side), for the position detector.

NOTE

Specify the number of feedback pulses per rotation about the tool axis for the position detector, considering the gear ratio with respect to the position coder.

7773

Number of position detector pulses per rotation about workpiece axis

[Data type] 2-word**[Data unit]** Detection unit**[Valid data range]** 1 to 99999999

This parameter specifies the number of pulses per rotation about the workpiece axis (on the fourth axis side), for the position detector.

[Example] The number of feedback pulses for the position detector is 360000 for a rotation axis for which the detection unit is 0.001 deg.

Alarm and message

Number	Message	Contents
181	FORMAT ERROR IN G81 BLOCK (gear hobbing machine, EGB)	G81 block format error 1) T (number of teeth) has not been instructed. 2) Data outside the command range was instructed by either T, L, Q or P. 3) Calculation of the synchronous coefficient has overflowed. Modify the program.
184	ILLEGAL COMMAND IN G81 (gear hobbing machine, EGB)	A command not to be instructed during synchronous operation by G81 was instructed. 1) A C axis command by G00, G27, G28, G29, G30, etc. was instructed. 2) Inch/Metric switching by G20, G21 was instructed. Modify the program.
186	PARAMETER SETTING ERROR (gear hobbing machine, EGB)	Parameter error regarding G81 (hobbing machine) 1) The C axis has not been set to be a rotary axis. 2) A hob axis and position coder gear ratio setting error. Modify the parameter.

Reference item

Series 16i/18i/160i/180i/ 160is/180is	OPERATOR'S MANUAL (For Machining Center) (B-63534EN)	II.20.8	Simple electric gear box (G80, G81)
---	--	---------	--

1.14.2 Spindle Electronic Gear Box (M series)

General

A gear can be shaped (grind/cut) by the synchronization of the workpiece axis rotation to the tool axis (grinding axis /hob) rotation by using two spindles as a tool axis and a workpiece axis. To synchronize these two axes, the Electronic gear box (EGB) is used.

In the Spindle EGB, the synchronous pulse is produced from the feedback pulse of the position detector attached to the tool axis (master axis) in the motor control, and the workpiece axis (slave axis) rotates with the pulse. Feedback pulse from Master side to Slave side is forwarded by the communication between spindle amplifiers.

The specifications of the Spindle EGB control are as follows:

- 1) The Spindle EGB synchronization is started by specifying T command (number of teeth) and L command (number of hob threads), which determine the synchronous ratio, in G81 block. The Spindle EGB synchronization is canceled by specifying G80.
- 2) The synchronous ratio is calculated from T and L command in G81 block and the number of position detector pulses per rotation about the tool and the workpiece axis (parameter setting).
- 3) This function has the retract function like the hobbing function.
- 4) The cutting helical gear is performed by specifying Q command (module or diametral pitch) and P command (gear helix angle) in G81 block.
- 5) The Spindle EGB synchronization is maintained regardless of whether the operation is automatic or manual.

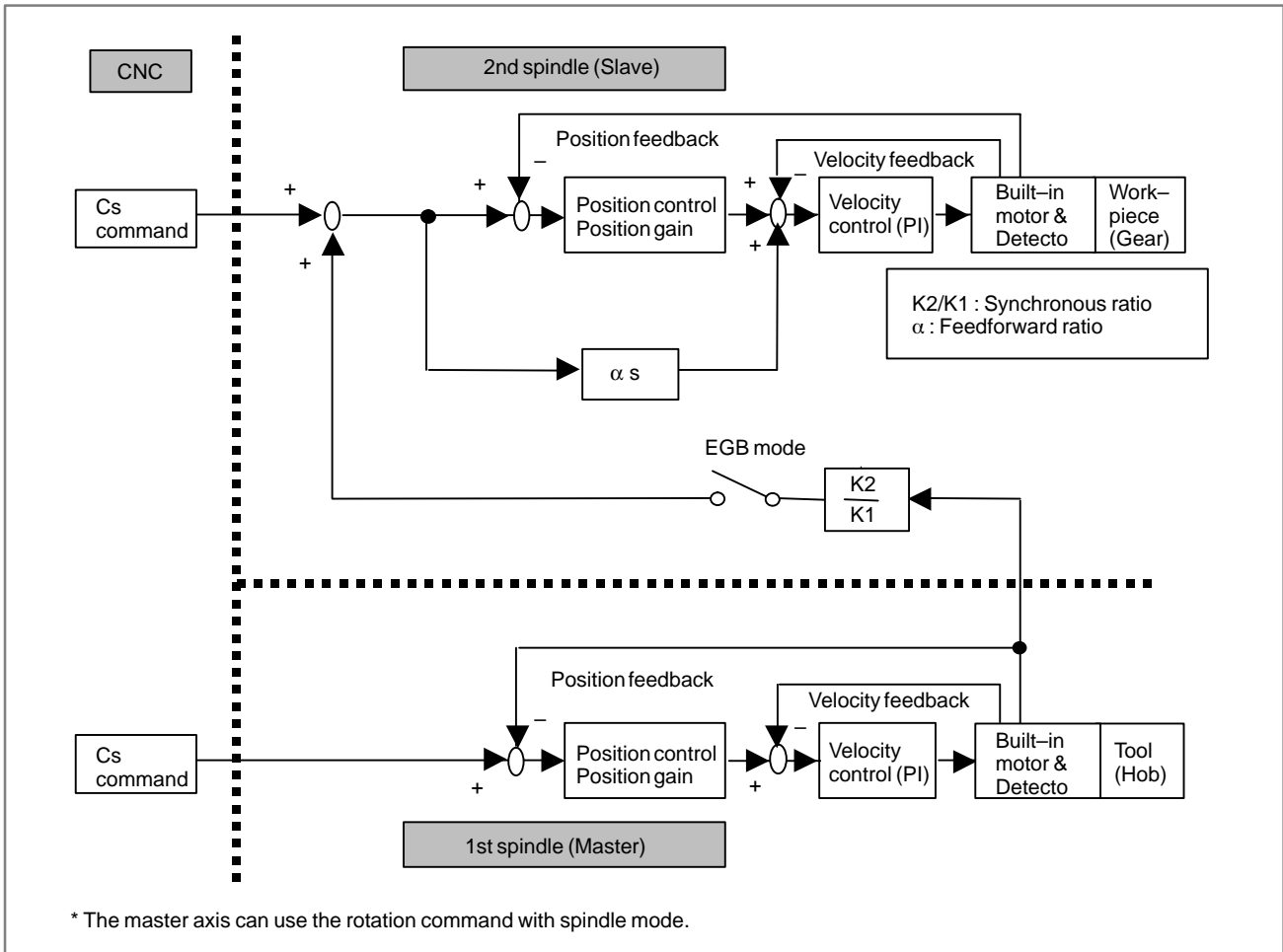

Fig.1.14.2(a) Block diagram for Spindle EGB control

Format

G81 T _ L _ Q _ P _ ; Starts synchronization.
G80 ; Cancels synchronization.

T : Number of teeth (Specifiable range : 1 to 1000)
 L : Number of hob threads (Specifiable range : -200 to +200 with 0 excluded)
 Q : Module or diametral pitch
 Specify a module in the case of metric input.
 (Unit : 0.00001mm, Specifiable range : 0.01 to 25.0mm)
 Specify a diametral in the case of inch input.
 (Unit : 0.00001inch⁻¹, Specifiable range : 0.01 to 25.0inch⁻¹)
 P : Gear helix angle
 (Unit : 0.0001deg, Specifiable range : -90.0 to 90.0deg)

NOTE
 Specify G81 and G80 code only in a block.

Parameter setting

The following parameters should be set for the Spindle EGB control.

- (1) Master axis number (Parameter No.7771) * Only Cs contour axis
- (2) Slave axis number (Parameter No.7710)
- (3) Number of position detector pulses per rotation about master axis (Parameter No.7772)
- (4) Number of position detector pulses per rotation about slave axis (Parameter No.7773)
- (5) Spindle EGB master axis enable (Parameter No.4352#7)
- (6) Spindle EGB slave axis enable (Parameter No.4352#6)
- (7) Number of sinusoidal waves from master spindle position detector (Parameter No.4386)

NOTE

The master axis number should be set smaller than the slave axis number.

Starting/canceling of synchronization

When the rotation of the tool axis (master axis) starts after G81 is specified, the EGB synchronization starts with the synchronous relationship specified in G81 block, and the rotation of the workpiece axis (slave axis) starts. When the EGB synchronization starts, the synchronization mode signal SYNMOD(F65#6) is turned to "1".

When the rotation of the tool axis is stopped, the workpiece axis stopped in synchronism. Then the EGB synchronization is canceled by specifying G80. When the EGB synchronization is canceled, the synchronization mode signal SYNMOD(F65#6) is turned to "0".

G81 cannot be specified again during the EGB synchronization. Moreover, the specification of T, L, Q, and P cannot be modified during the synchronization. Specify the starting and canceling of synchronization at the tool axis (master axis) stopping.

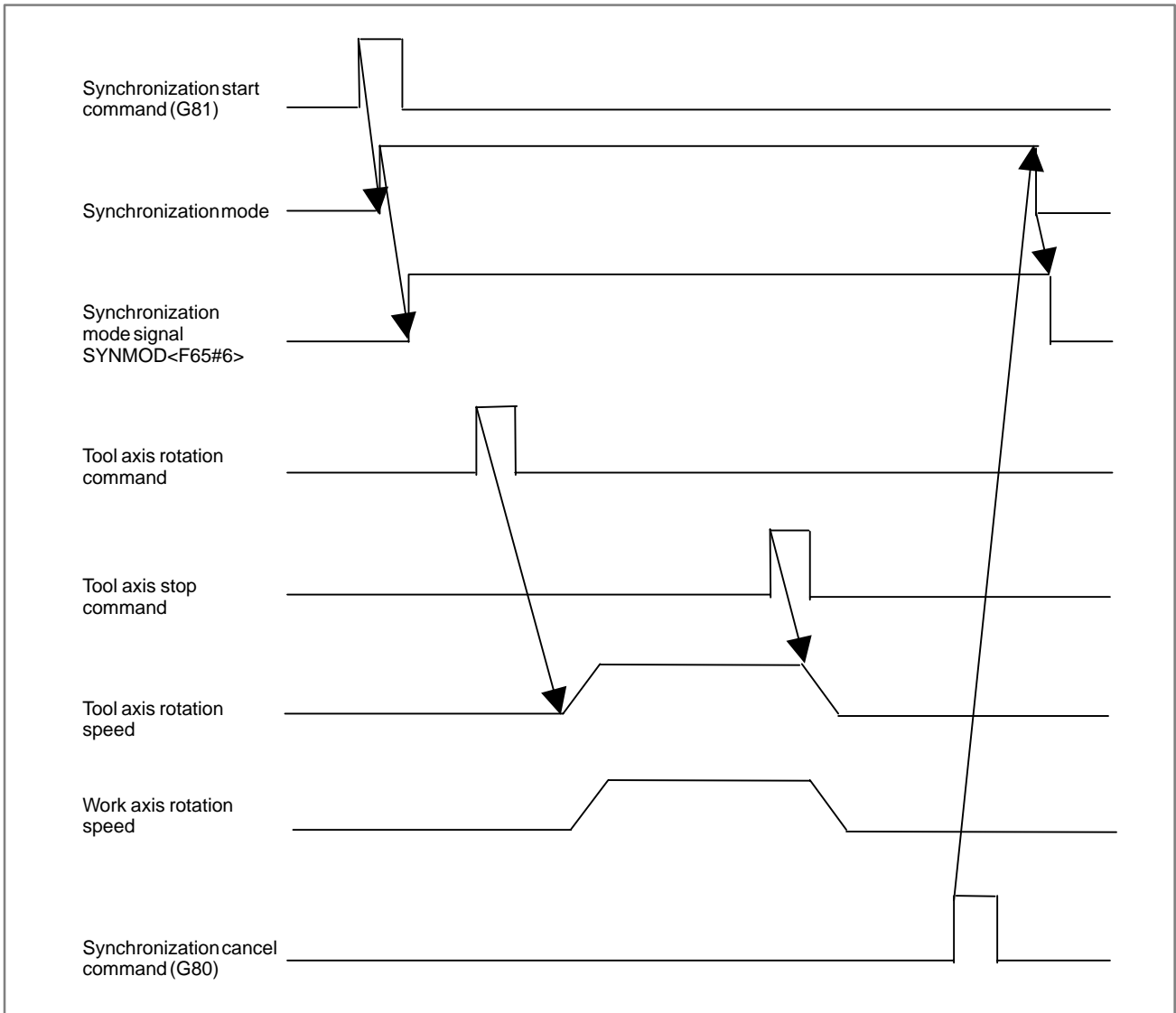

Fig. 1.14.2(b) Example timing for starting/canceling synchronization

Program example

Axis configuration	X,Y,Z, B (Cs axis: tool axis/master axis), C (Cs axis: workpiece axis/slave axis)
O1000 ;	
N00010 G80 ;	
N00020 G28 G91 B0 C0 ;	Performs reference position return operation of the tool and the workpiece axis.
N00030 G81 T20 L1 ;	Starts synchronization.
N00040 Mxx ;	Rotates the tool axis by velocity command of PMC axis control.
N00050 G04 X1000 ;	Waits until rotation of the tool axis is constant.
N00060 G01 X_ F_ ;	Makes movement on the X-axis(for cutting).
N00070 G01 Z_ F_ ;	Makes movement on the Z-axis(for machining).
<hr/>	
N00100 G01 X_ F_ ;	Makes movement on the X-axis(for retraction).
N00110 Myy ;	Stops the tool axis.
N00120 G80 ;	Cancels synchronization.
N00130 M30 ;	

Helical gear compensation

When a helical gear is to be produced, the compensation of the workpiece axis rotation is needed according to the travel distance on the Z-axis (axial feed axis: parameter No. 7709 setting). Helical gear compensation is performed by adding compensation pulses calculated from the formula below to the workpiece axis.

$$\text{Compensation angle} = \frac{Z \times \sin(P)}{\pi \times T \times Q} \times 360 \text{ (For metric input)}$$

or

$$\text{Compensation angle} = \frac{Z \times Q \times \sin(P)}{\pi \times T} \times 360 \text{ (For inch input)}$$

where

Compensation angle : Signed absolute value (deg)

Z: Amount of travel on the Z-axis after the specification of G81 (mm or inch)

P: Signed gear helix angle (deg)

T: Number of teeth

Q: Module (mm) or diametral pitch (inch⁻¹)

The values of P, T, Q, are to be programmed.

In helical gear compensation, the machine coordinates and absolute coordinates of the workpiece axis are updated by the amount of helical gear compensation. When P command and Q command are not specified in G81 block, helical gear compensation is not performed.

The direction of helical gear compensation is determined by bit 2 (HDR) of parameter No.7700 (1 is usually specified). The compensation direction is shown in figure 1.14.2(c).

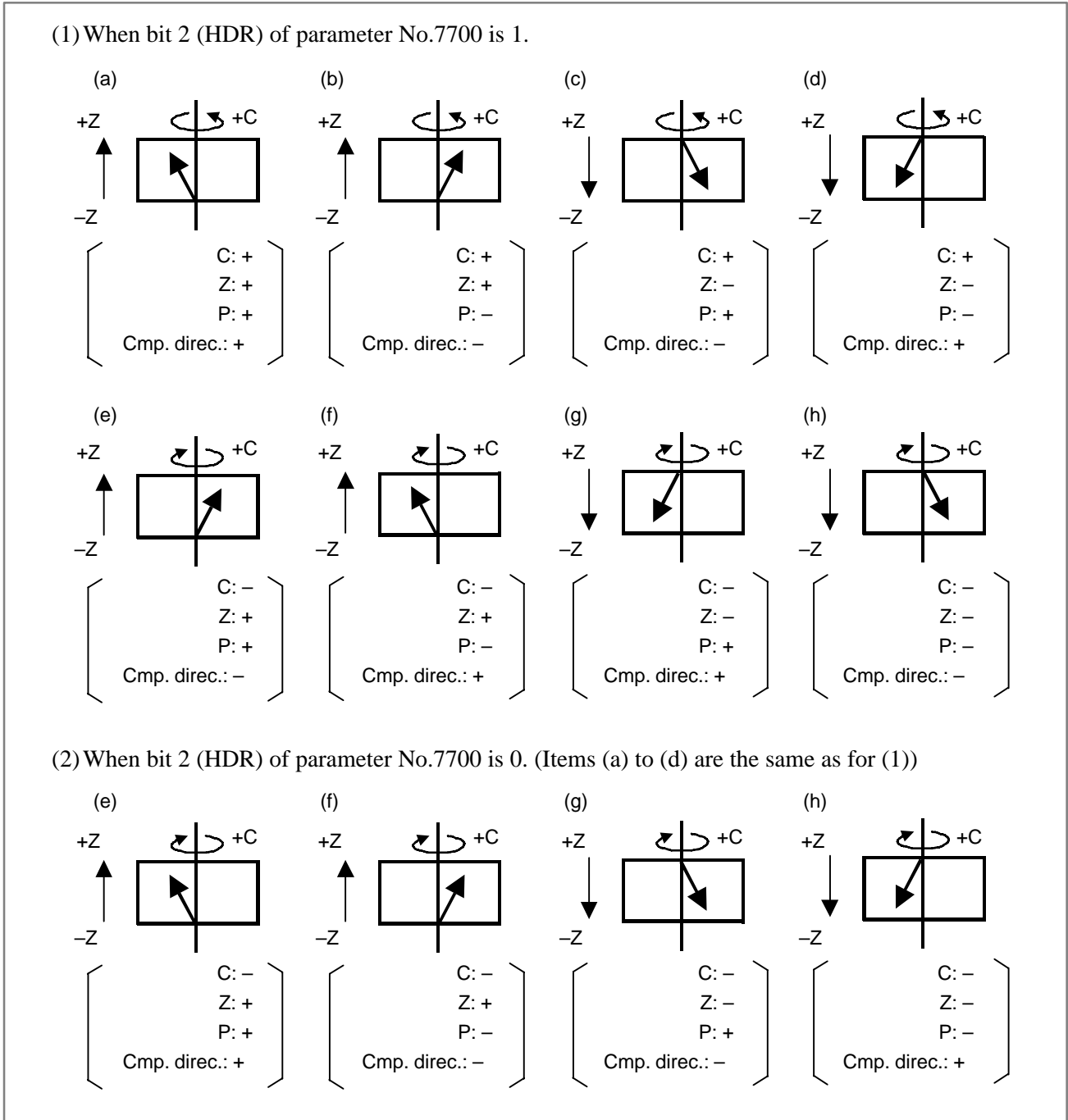

Fig.1.14.2(c) Direction of helical gear compensation

Synchronous ratio

The synchronous ratio of the Spindle EGB control is internally represented using a fraction. The fraction is calculated from T and L command in G81 block and the number of position detector pulses per rotation about the tool and the workpiece axis (parameter setting).

$$\text{Synchronous ratio} : \frac{K2}{K1} = \frac{L}{T} \times \frac{\beta}{\alpha}$$

L: Hob threads

T: Number of teeth of the work

α : Number of position detector pulses per revolution about the tool axis (Parameter No.7772)

β : Number of position detector pulses per revolution about the workpiece axis (Parameter No.7773)

This synchronous ratio is reduced to the lowest term, and it has the following limit.

$$\begin{aligned} -32767 < K2 < 32767 \\ 1 < K1 < 65535 \end{aligned}$$

When K2 or K1 is out of this range, P/S alarm (No.181) occurs.

The values of K2 and K1 are set to the parameter No.4387 and No.4388 automatically when G81 is specified. If T is not specified in G81 block, P/S alarm (No.181) occurs. If L is not specified in G81 block, the synchronous ratio is calculated as L = 1.

Example) When the pulses for one rotation (360000) are specified to the tool axis (master axis) on the following conditions, the pulses for position control are distributed as figure 1.14.2(d).

Hob threads L : 10

Number of teeth of the work T : 100

Number of pulse per one revolution of position detector on the tool axis α : 360000

Number of pulse per one revolution of position detector on the work axis β : 360000

$$\text{Synchronous ratio} : \frac{K2}{K1} = \frac{L}{T} \times \frac{\beta}{\alpha} = \frac{10}{100} \times \frac{360000}{360000} = \frac{1}{10}$$

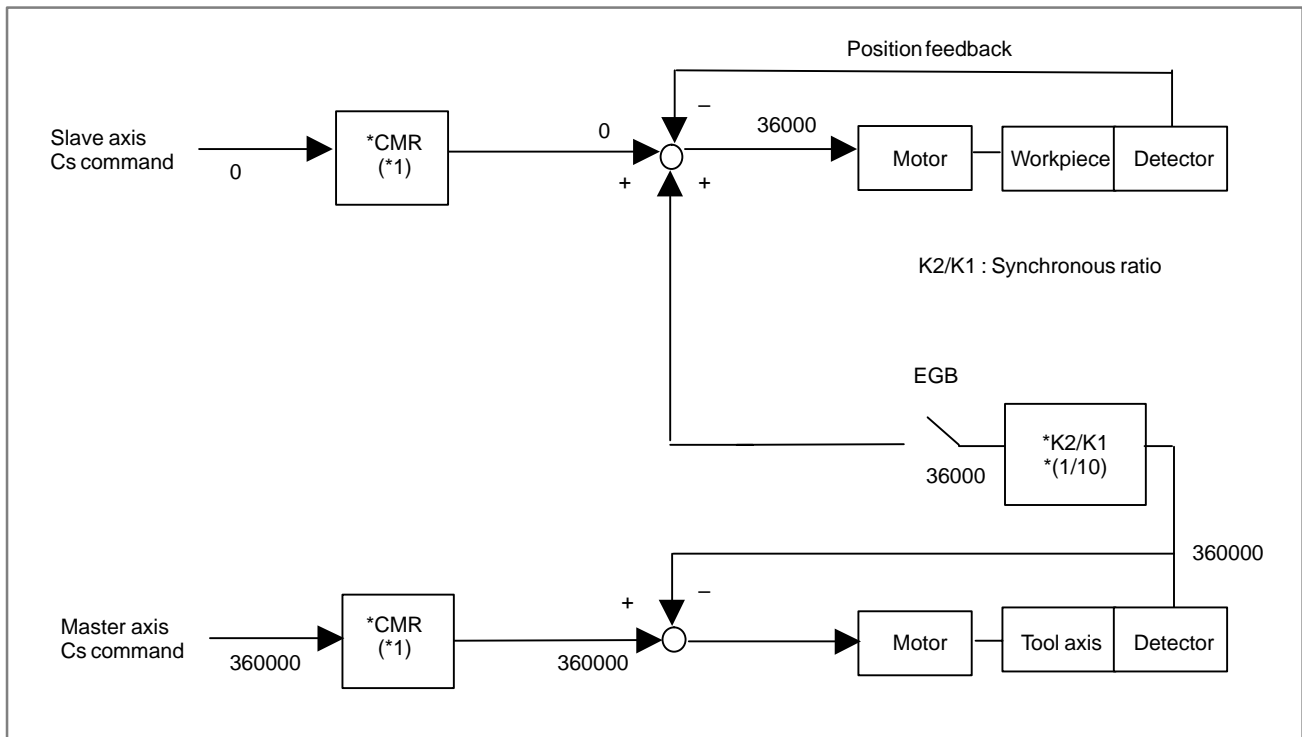

Fig. 1.14.2(d) Pulse distribution

As Fig. 1.14.2(d), when 360000 pulses (Number of pulse for one rotation of the master axis) are specified, the pulses for slave axis by EGB are equal to the value which is multiplied to the number of pulse for one rotation of the slave axis by the ratio of Hob thread and number of teeth (rotation ratio between master axis and slave axis).

$$360000 \times 1/10 = 36000$$

Retract function

When the retract signal RTRCT(G66#4) is turned to "1" in auto mode (MEM, MDI, etc.) or manual mode (HNDL, JOG etc.), the axis set in bit 0 (RTR) of the parameter No.7730 moves (retracts) by the amount set in the parameter No.7741.

NOTE

- 1 Feedrate in retract is set to the parameter No.7740. Then the feedrate override is not effective.
- 2 During the movement in retract, feed hold is not effective.
- 3 In case that retract signal is turned to "1" in auto mode, the movement of the auto mode is hold and the retract movement is done.

Parameter

● Parameters for serial spindle

4036	Feed forward coefficient for serial spindle
------	---

[Data type] Word

[Valid data range] 0 to 10000

Feed forward coefficient for Cs contour control axis is set.
 Specified value is smaller than or equal to 100 : In units of 1%
 Specified value is greater than 100 : In units of 0.01%

4352	#7	#6	#5	#4	#3	#2	#1	#0
	SPEGBM	SPEGBS						

[Data type] Bit

SPEGBS The spindle EGB function for slave spindle is:
 0 : Disabled.
 1 : Enabled.

SPEGBM The spindle EGB function for master spindle is:
 0 : Disabled.
 1 : Enabled.

4386	Number of sinusoidal waves from master spindle position detector
------	--

[Data type] Word

[Valid data range] 64 to 4096

Specify the number of sinusoidal waves per spindle 1 rev. from the master spindle position detector.
 This parameter should be set to the slave spindle amplifier.
 Setting this parameter to 0 is equivalent to the synchronous ratio 0.

4387	Numerator of synchronous ratio
------	--------------------------------

[Data type] Word

[Valid data range] -32767 to 32767

Numerator of synchronous ratio is set to this parameter automatically when G81 is specified.

4388	Denominator of synchronous ratio
------	----------------------------------

[Data type] Word

[Valid data range] 1 to 65535

Denominator of synchronous ratio is set to this parameter automatically when G81 is specified.

● Parameters for synchronous control

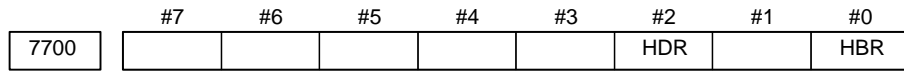

[Data type] Bit axis

HBR The synchronization is :
 0 : Canceled by reset.
 1 : Not canceled by reset.
 1 is usually specified.

HDR Setting of the direction for compensating a helical gear
 (1 is usually specified.)

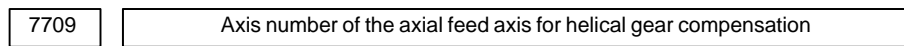

[Data type] Byte

[Valid data range] 1 to the maximum number of controlled axes

This parameter sets the number of the axial feed axis for a helical gear. If the value out of the valid range is specified, 3(the 3rd axis) is specified.

NOTE
 After setting this parameter, the power must be turned off then on again in order to activate the new setting.

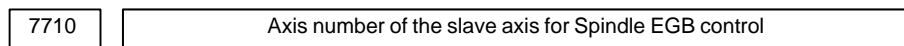

[Data type] Byte

[Valid data range] 1 to the maximum number of controlled axes

This parameter sets the number of the slave axis for Spindle EGB control. If the value out of the valid range is specified, 4(the 4th axis) is specified. The slave axis number should be set larger than the master axis number (No.7771).

NOTE
 After setting this parameter, the power must be turned off then on again.

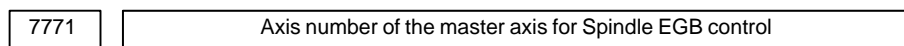

[Data type] Byte

[Valid data range] 1 to the maximum number of controlled axes

This parameter sets the number of the master axis for Spindle EGB control. The master axis number should be set smaller than the master axis number (No.7710).

NOTE

After setting this parameter, the power must be turned off then on again.

7772 Number of position detector pulses per rotation about tool axis

[Data type] 2-Word

[Data unit] Detection unit

[Valid data range] Set 360000 to this parameter.

This parameter specifies the number of pulses per rotation about the tool axis (master axis), for the position detector.

7773 Number of position detector pulses per rotation about workpiece axis

[Data type] 2-Word

[Data unit] Detection unit

[Valid data range] Set 360000 to this parameter.

This parameter specifies the number of pulses per rotation about the workpiece axis (slave axis), for the position detector.

● Parameters for retract function

	#7	#6	#5	#4	#3	#2	#1	#0
7730								RTRx

[Data type] Bit axis

RTRx The retract function is :
 0 : Disabled.
 1 : Enabled.

7740 Feedrate during retraction for each axis

[Data type] 2 Word axis

[Unit of data]	Increment system	Unit of data	Valid data range	
			IS-B	IS-C
[Valid data range]	Metric machine	1 mm/min	30 to 240000	30 to 100000
	Inch machine	0.1 inch/min	30 to 96000	30 to 48000

This parameter sets the feedrate during retraction for each axis

7741	Retracted distance for each axis
------	----------------------------------

[Data type] 2 Word axis

[Unit of data]	Increment system	Unit of data	
		IS-B	IS-C
	Metric input	0.001 mm	0.0001 mm
Inch input	0.0001 inch	0.00001 inch	

[Valid data range] -99999999 to 99999999

This parameter sets the retracted distance for each axis

Signal

Synchronization mode signal SYNMOD<F065#6>

[Classification] Output signal

[Function] Confirmation of the EGB synchronization

[Operation] The signal becomes "1" when :

- The EGB synchronization is active.

The signal becomes "0" when :

- The EGB synchronization is canceled.

Retract signal RTRCT<G066#4>

[Classification] Input signal

[Function] Performs retraction for the axis specified with a parameter.

[Operation] When this signal turns to "1", the control unit performs the following:
Performs retraction on the axis specified with bit 0 (RTRx) of parameter No.7730. The retract speed and amount of retraction are specified with parameter Nos.7740 and 7741.

The retract signal is effective both in automatic operation mode and manual operation mode. When the retract signal turns to "1" during automatic operation, retraction is performed and the CNC enters feed hold state.

Retract completion signal

RTRCTF<F065#4>

[Classification] Output signal

[Function] Posts notification of the completion of retraction.

[Operation] The signal becomes "1" when :

- Upon the completion of retraction.

The signal becomes "0" when :

- Upon the completion of retraction, when the axis is specified after that.

NOTE

The retract signal is not accepted while the retract completion signal is set to "1".

Signal address

	#7	#6	#5	#4	#3	#2	#1	#0
F065		SYNMOD		RTRCTF				
	#7	#6	#5	#4	#3	#2	#1	#0
G066				RTRCT				

Alarm and message

Number	Message	Contents
010	IMPROPER G-CODE	Parameters for axis setting are not set correctly regarding G81. (No.7710, 7771, 4352, or Cs axis setting). Confirm the parameter setting.
181	FORMAT ERROR IN G81 BLOCK	G81 block format error 1) T(number of teeth) has not been instructed. 2) Data outside the command range was instructed by either T, L, Q, or P. 3) Calculation of the synchronous ratio has overflowed. Modify the program.
184	ILLEGAL COMMAND IN G81	A command not to be instructed during synchronization was instructed. 1) The slave axis is specified by G00, G28, G27, G29, G30. 2) Inch/metric conversion by G20, G21 was instructed. 3) Cs contour control mode is not selected.
186	PARAMETER SETTING ERROR	Parameter error regarding G81 1) The slave axis has not been set to be a rotary axis.

Cautions

- 1) The EGB synchronization is not canceled by RESET when bit 0 (HBR) of parameter No.7700 is set to 1. Set 1 to this parameter usually.
- 2) The EGB synchronization performed even under the following operation of the slave axis.
 - Interlock
 - Feed hold
 - Machine lock
- 3) The EGB synchronization should be started and canceled at the stop of the master and the slave axis. It means that the tool axis (master axis) rotation should be started while the synchronization mode signal SYNMOD<F065#6> is "1" (Refer to Fig.1.14.2(b) Example timing for starting/ canceling synchronization). If the tool axis (master axis) starts to rotate before the synchronization mode signal SYNMOD <F065#6> is "1", the synchronization does not perform correctly.
- 4) Reference position return of Cs contouring control axis for master and slave axis should be performed before G81 is specified. In the synchronization mode, reference position return cannot be performed. Do not change to reference position return mode in the synchronization mode.
- 5) In case that the parameters for axis setting (No.7710,7771,4352) are not set correctly, P/S alarm (No.010) occurs when G81 specified.
- 6) When G28/G27/G29G30/G30.1/G53 is specified in the synchronization mode, P/S alarm (No.184) occurs. G28/G27/G29/G30/G30.1/G53 should not be specified in the synchronization mode.
- 7) During high-precision contour control, the high-speed cycle cutting, the high-speed liner interpolation, the high-speed remote buffer A, the high-speed remote buffer B of DNC operation, and AI contour control, this function is not available.
- 8) The slave axis position display is updated by synchronous pulse as follows :
 - Machine position display is updated.
 - Absolute position display and relative position display are not updated. When the synchronization is canceled, the pulses of the synchronization are added to the absolute position display of the slave axis.
- 9) The rotation direction of the workpiece axis depends on the rotation direction of the tool axis. That is, when the rotation direction of the tool axis is positive, the rotation direction of the workpiece axis is also positive; when the rotation direction of the tool axis is negative, the rotation direction of the workpiece axis is also negative. However, by specifying a negative value for L, the rotation direction of the workpiece axis can be made opposite to the rotation direction of the tool axis.
- 10) During synchronization, a move command can be programmed for the workpiece axis. Note, however, that incremental command programming for cutting feed must be used to specify the workpiece axis move command.
- 11) The synchronization mode is canceled by servo alarm, spindle alarm, P/S alarm (No.000), or emergency stop.

- 12) The synchronization is not maintained in servo off status of the slave axis.
- 13) When the EGB control is used, the drilling canned cycle cannot be used.
- 14) The actual feedrate is displayed without the flexible synchronous pulse.

Reference item

CONNECTION MANUAL (This manual)	1.14.1	Simple electronic gear box
------------------------------------	--------	----------------------------

1.14.3 Electronic Gear Box Automatic Phase Synchronization (M Series)

Outlines

In the electronic gear box (EGB), when synchronization start or cancellation is specified, synchronization is not started or canceled immediately.

Instead, acceleration/deceleration is executed first. Therefore, synchronization can be started or canceled while the spindle is rotating. Also, synchronization ratio can be changed while the spindle is rotating. At synchronization start, automatic phase synchronization is performed such that the workpiece axis position matches the position corresponding to the spindle one-rotation signal. With this synchronization, the same operation is performed as synchronization start caused by a one-rotation signal in hobbing synchronization when using the functions of a hobbing machine.

The spindle corresponds to the EGB master axis and the workpiece axis corresponds to an EGB slave axis (Servo axis or Cs contouring axis).

Acceleration/ deceleration type

Format

G81 T _ L _ R1 ; Synchronization start
G80 R1 ; Synchronization end

T : Number of teeth (range of valid settings: 1-1000)

L : Number of hob threads (range of valid settings: -200 to +200, excluding 0)

When L is positive, the direction of rotation about the workpiece axis is positive (+ direction).

When L is negative, the direction of rotation about the workpiece axis is negative (- direction).

Command sequence

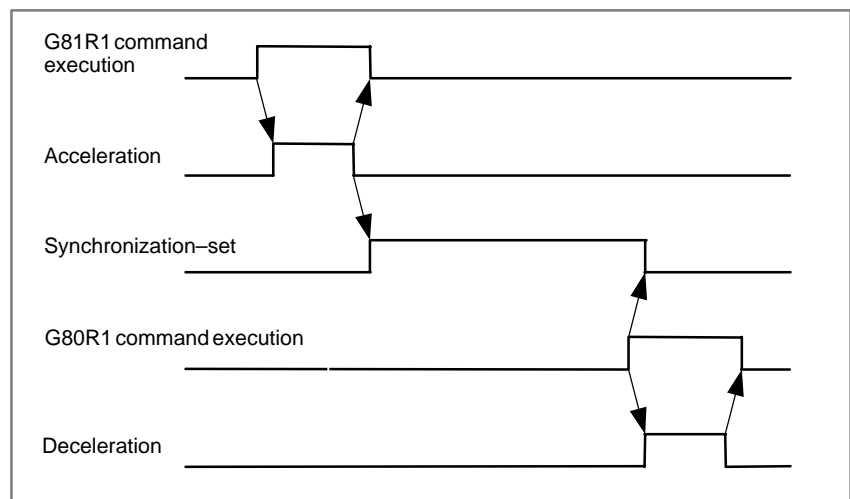
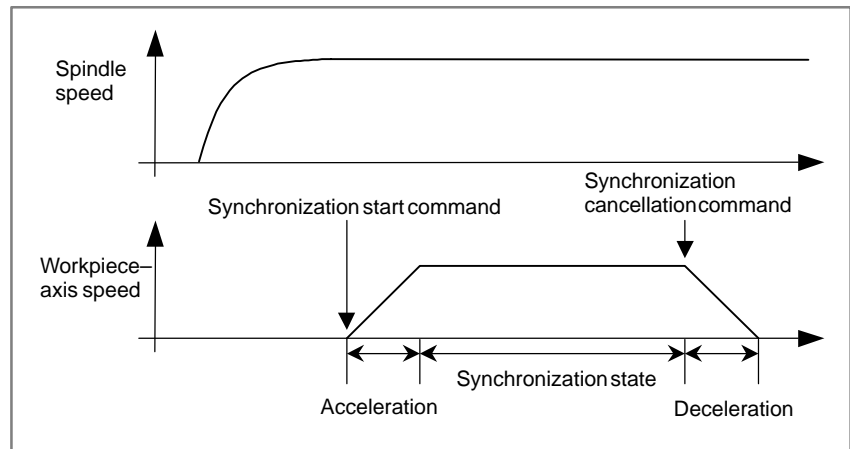

1. Specify G81R1 to start synchronization.
When G81R1 is specified, acceleration according to the acceleration rate set in the parameter (No.2135,2136 or No.4384,4385) is performed on the workpiece axis (slave axis). Once the synchronization feedrate is reached, synchronization mode signal SYNMOD is set to 1, and the G81R1 block is terminated.
2. For cancellation, specify G80R1 while the tool is moved away from the workpiece.
3. When G80R1 is specified, the EGB mode check signal is set to 0, and deceleration according to the acceleration rate set in the parameter (No. 2135,2136 or No.4384,4385) is started immediately. When the speed is reduced to 0, the G80R1 block is terminated.

NOTE

- 1 Linear acceleration/deceleration applies to synchronization start/cancellation.
- 2 In automatic synchronization cancellation due to Reset or P/S alarm (No.000), deceleration is executed and synchronization is canceled.

Acceleration/deceleration plus automatic phase synchronization type

Format

G81 T _ L _ R2 ; Synchronization start
G80 R2 ; Synchronization end

T : Number of teeth (range of valid settings: 1–1000)
 L : Number of hob threads (range of valid settings: –200 to +200, excluding 0)
 When L is positive, the direction of rotation about the workpiece axis is positive (+ direction).
 When L is negative, the direction of rotation about the workpiece axis is negative (– direction).

Command sequence

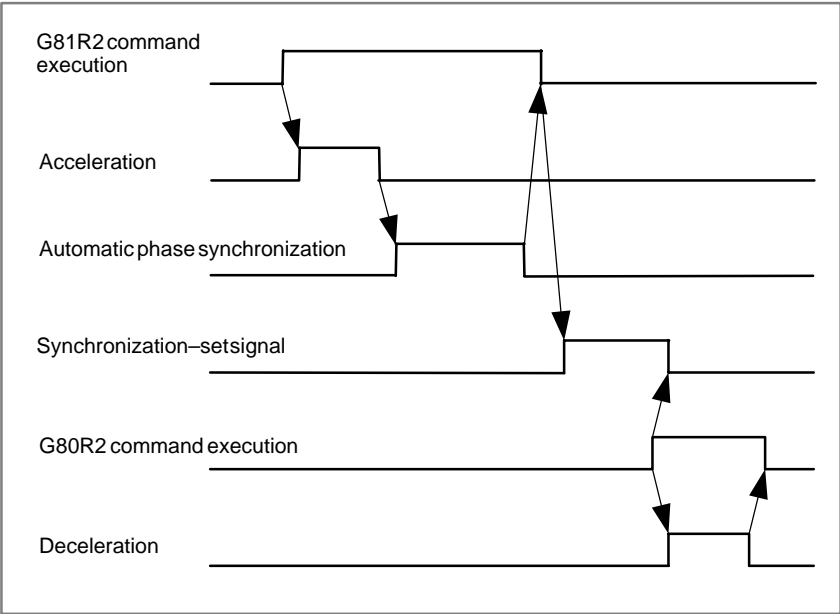
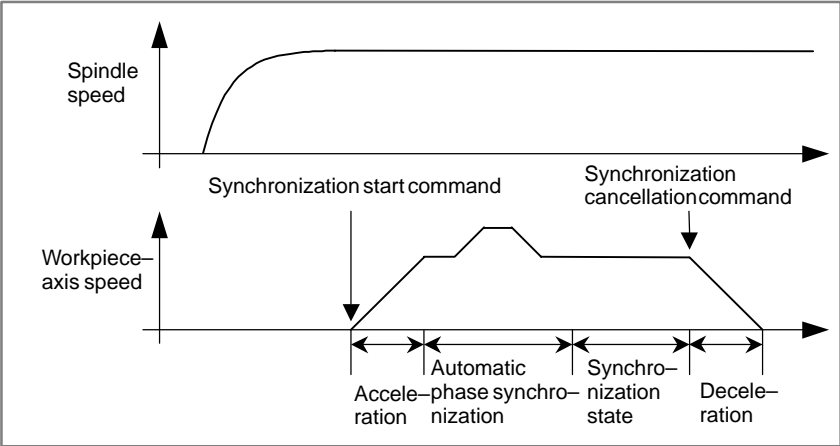

1. Move the workpiece axis to the position that corresponds to that of the one-rotation signal of the spindle.

2. Specify G81R2 to start synchronization.
When G81R2 is specified, the workpiece axis is accelerated with the acceleration according to the acceleration rate set in the parameter (No.2135, 2136 or No.4384, 4385). When the synchronization speed is reached, phase synchronization is performed automatically. Upon the completion of phase synchronization, synchronization mode signal SYNMOD is set to 1, and the G81R2 block is terminated.
3. For cancellation, specify G80R2 while the tool is moved away from the workpiece.
4. When G80R2 is specified, the synchronization mode signal is set to 0, and deceleration according to the acceleration rate set in the parameter (No.2135,2136 or No.4384,4385) is started immediately. When the speed is reduced to 0, the G80R2 block is terminated.

CAUTION

In automatic phase synchronization, specify the speed in parameter No.7776 and the movement direction in parameter PHD, bit 7 of No. 7702.

In phase synchronization, rapid-traverse linear acceleration/deceleration (with the time constant specified in parameter No. 1620) is performed.

The workpiece-axis speed is obtained by superposing the speed in automatic phase synchronization onto the speed corresponding to spindle rotation.

In consideration of this superposition, specify a position deviation limit in parameter No. 1828.

NOTE

- 1 The one-rotation signal used for automatic phase synchronization is issued not by the spindle position coder but by the separate pulse coder attached to the spindle and used to collect EGB feedback information. This means that the orientation position based on the one-rotation signal issued by the spindle position coder does not match the position used as the reference for the workpiece axis when establishing phase synchronization for automatic phase synchronization based on G81R2.
Moreover, the one-rotation signal of the separate pulse coder must be turned on for each rotation of the spindle.
- 2 With the use of parameter No.7777, the position at which the phase of the workpiece axis is matched can be shifted from the position corresponding to the one-rotation signal in automatic phase matching.
- 3 In automatic phase synchronization, when a synchronization command is issued again in a synchronization state, movement about the workpiece axis is performed such that the position corresponding to the one-rotation signal of the spindle matches the position about the workpiece axis specified in the G81R2 synchronization start command executed first.
- 4 In automatic phase synchronization, movement is performed about the workpiece axis from the current position to the nearest phase position in the phase synchronization movement direction specified by the parameter.
- 5 Linear acceleration/deceleration applies to synchronization start/cancellation.
- 6 The acceleration/deceleration plus automatic phase synchronization type can be executed by the PHS parameter, bit 6 of No.7702, without specifying an R2 command in a G81 or G80 block.
- 7 In automatic synchronization cancellation due to Reset or P/S alarm (No.000), deceleration is executed and synchronization is canceled.
- 8 This item is for spindle EGB.
If the control mode of the master axis is the speed control, it is necessary to execute the position coder orientation before that the automatic phase synchronization is started. In this case, RFCHK3 (PRM4016#7) of the master axis must be set "0" to keep memorizing the one-rotation signal position of the spindle in the speed control mode.
- 9 This item is for spindle EGB.
If the control mode of the master axis is Cs contouring, it is necessary to execute the reference point return before that the automatic phase synchronization is started.
- 10 The acceleration rate parameter (No.2135, 2136 or No.4384, 4385) must not be changed in the synchronization mode.
- 11 Do not cancel the synchronous mode by the reset when this function is used. (Set "1" in parameter No.7700#0 HBR.)

Program example

● **Acceleration/deceleration type**

M03 : Clockwise spindle rotation command
 G81 T_ L_ R1 ; Synchronization start command
 G00 X_ ; Positions the workpiece at the machining position.

Machining in the synchronous state

G00 X_ ; Retract the workpiece from the tool.
 G81 T_ L_ R1 ; Synchronization ratio change.
 G00 X_ ; Positions the workpiece at the machining position.

Machining in the synchronous state

G00 X_ ; Retract the workpiece from the tool.
 G80 R1 ; Synchronization cancel command

● **Acceleration/deceleration and automatic phase synchronization**

M03 ; Clockwise spindle rotation command
 G00 G90 C_ ; C-axis positioning
 G81 T_ L_ R2 ; Synchronization start command
 G00 X_ ; Positions the workpiece at the machining position.

Machining in the synchronous state

G00 X_ ; Retract the workpiece from the tool.
 G81 T_ L_ R2 ; Synchronization ratio change.
 G00 X_ ; Positions the workpiece at the machining position.

Machining in the synchronous state

G00 X_ ; Retract the workpiece from the tool.
 G80 R2 ; Synchronization cancel command

● **About the direction of the rotation (This item is for spindle EGB.)**

The EGB automatic phase synchronization is made on the premise that the rotation of the slave axis is the same direction as the master axis. Refer to the following chart.

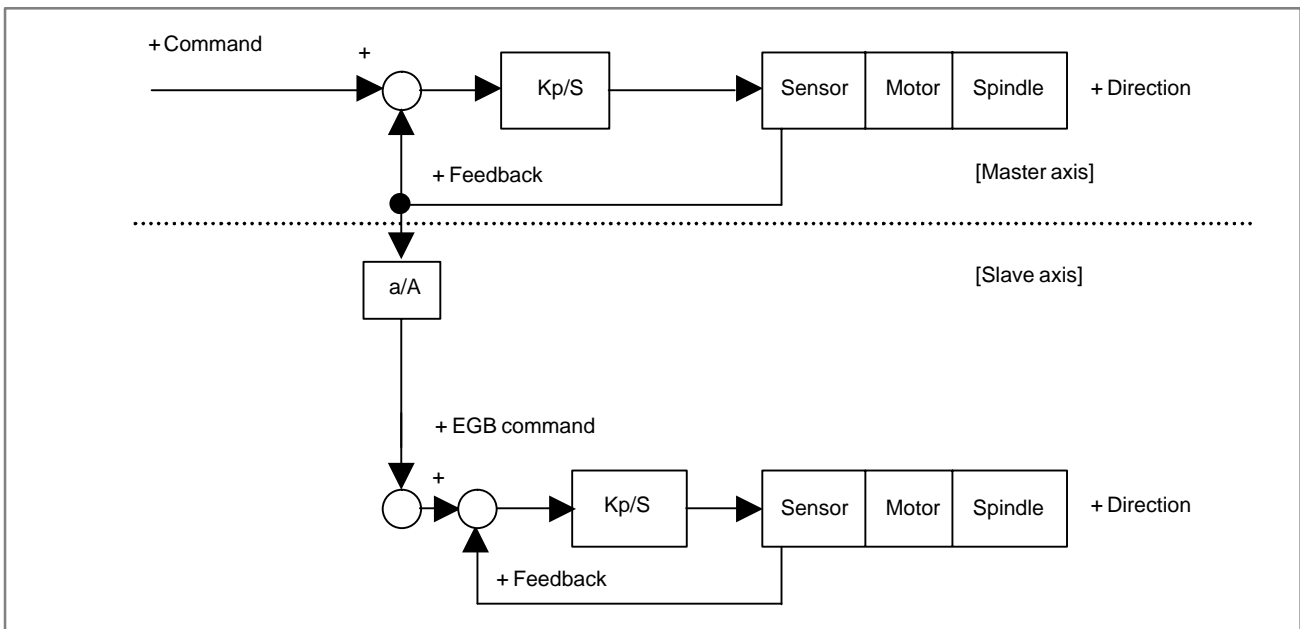

When this function is used, the SFR/SRV function in Cs contouring mode (*) can not use. If you want to change the rotary direction of the master axis, you should change the sign of the master axis command.

(*) The SFR/SRV function in Cs contouring mode

This function is that the signal SFR/SRV decides the rotary direction of the spindle in the Cs contouring mode.

Signal

Synchronization mode signal SYNMOD<F065#6>

[Classification] Output signal

[Function] Confirmation of the EGB synchronization

[Operation] The signal becomes "1" when :

- The EGB synchronization is active.

The signal becomes "0" when :

- The EGB synchronization is canceled.

Signal address

	#7	#6	#5	#4	#3	#2	#1	#0
F065		SYNMOD						

Parameter

	#7	#6	#5	#4	#3	#2	#1	#0
7702	PHD	PHS						

[Data type] Bit

PHS Specifies whether to perform acceleration/deceleration when EGB synchronization is started or canceled if there is no R command in a G81/G80 block.

0 : Do not perform acceleration/deceleration when EGB synchronization is started or canceled.

1 : Perform acceleration/deceleration when EGB synchronization when EGB synchronization is started or canceled, and automatically perform phase synchronization after acceleration when synchronization starts.

PHD Specifies the direction of movement for automatic phase synchronization.

0 : Positive (+) direction

1 : Negative (-) direction

7710	Axis number of the slave axis for Spindle EGB control
------	---

[Data type] Byte

[Valid data range] 1 to the maximum number of controlled axes

This parameter sets the number of the slave axis for Spindle EGB control. If the value out of the valid range is specified, 4(the 4th axis) is specified. The slave axis number should be set larger than the master axis number (No.7771).

NOTE

After setting this parameter, the power must be turned off then on again.

7776 Speed for workpiece-axis automatic phase synchronization

[Data type] 2-Word

[Valid data range] 0 to 24000

[Unit of data]	Increment system		Unit of data	
			IS-B	IS-C
	Deg/min		10.0	1.0

When the setting value of this parameter is 0, as for the speed, the rapid speed (Parameter No.1420) is used.

7777 Angle deviation from the spindle position (position of the one-rotation signal) used as a reference for workpiece-axis phase synchronization

[Data type] 2-Word

[Valid data range] 0 to 3600000

[Unit of data]	Increment system		Unit of data	
			IS-B	IS-C
	Rotation axis		0.001deg	0.0001deg

	#7	#6	#5	#4	#3	#2	#1	#0
4000					RETRN		ROTA2	

(This parameter is for spindle EGB.)

[Data type] Bit

ROTA2 This bit must be set to "0 (the rotary direction of the spindle is CCW when the command sign is the positive)".

RETRN If the master axis is driven by the speed control during the EGB mode, this bit (the rotary direction of reference point return in Cs contouring mode) & DIRCT2, DIRCT1 (PRM4003#3,2 : the rotary direction of the spindle orientation) should be set as the following.

RETRN=0 & DIRCT2, DIRCT1=10 (CCW) or
 RETRN=1 & DIRCT2, DIRCT1=11 (CW)

	#7	#6	#5	#4	#3	#2	#1	#0
4001	CAXIS3							

(This parameter is for spindle EGB.)

[Data type] Bit

CAXIS3 If this bit is 1, the position feedback is reversed.

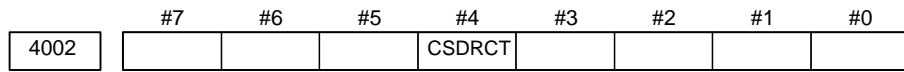

(This parameter is for spindle EGB.)

[Data type] Bit

CSDRCT SFR/SRV function in the Cs contouring mode

If you use the spindle EGB function, this bit must be set to "1".

In this case, the signal SFR/SRV only turn on/off the excitation of the spindle motor.

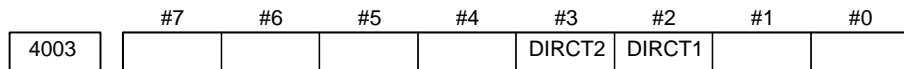

(This parameter is for spindle EGB.)

[Data type] Bit

DIRCT2, DIRCT1 These bits decide the rotary direction in the spindle orientation. Refer to the item of RETRN(PRM4000#3) about the setting.

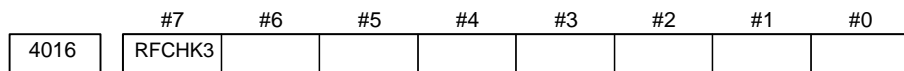

(This parameter is for spindle EGB.)

[Data type] Bit

RFCHK3 When the EGB master axis is driven by speed control mode, if you use automatic phase synchronization, you should set RFCHK3 of EGB master axis to "0".

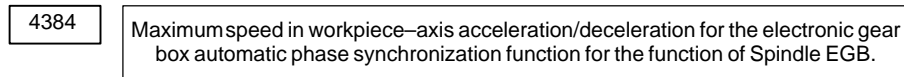

(This parameter is for spindle EGB.)

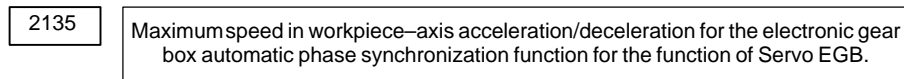

(This parameter is for servo EGB.)

[Data type] Word axis

[Valid data range] 0 to 32000

[Unit of data]

Increment system	Unit of data	
	IS-B	IS-C
Deg/min	10.0	1.0

4385	Time constant related to the maximum speed in workpiece-axis acceleration/deceleration for the electronic gear box automatic phase synchronization function for the function of Spindle EGB.
------	--

(This parameter is for spindle EGB.)

2136	Time constant related to the maximum speed in workpiece-axis acceleration/deceleration for the electronic gear box automatic phase synchronization function for the function of Servo EGB.
------	--

(This parameter is for servo EGB.)

[Data type] Word axis

[Valid data range] 0 to 2000

[Unit of data] msec

The acceleration used in workpiece-axis acceleration/deceleration is determined as follows:

$$\text{Acceleration} = \frac{\text{Maximum speed (Parameter No.4384 / No.2135)}}{\text{Time constant for the maximum speed (Parameter No.4385 / No.2136)}}$$

4386	Number of sinusoidal waves from master spindle position detector
------	--

(This parameter is for spindle EGB.)

[Data type] Word axis

[Valid data range] 64 to 4096, or -64 to -4096

Specify the number of sinusoidal waves per spindle 1 revolution from the position detector of the master axis.

This parameter should be set to the slave spindle amplifier.

If the setting value is negative, the slave axis inverses the master feedback as the EGB command.

If the setting value is "0", the slave axis doesn't read the master feedback as the EGB command.

Alarm and message

Number	Message	Contents
181	EGB AUTO PHASE FORMAT ERROR	Format error in block in which G80 or G81 was specified by EGB automatic phase synchronization (1) R is data outside of the instruction range. (2) Before the G81R2 command, the master spindle isn't returned to in the reference point. (In case of Spindle EGB)

1.14.4 Electronic Gear Box 2 Pair (M Series)

General

The Electronic Gear Box is a function for rotating a workpiece in sync with a rotating tool, or to move a tool in sync with a rotating workpiece. With this function, the high-precision machining of gears, threads, and the like can be implemented. A desired synchronization ratio can be programmed.

Up to two sets of axes can be synchronized. A gear grinding machine can be controlled, for instance, by using one axis for rotating the workpiece in sync with the tool and another axis for performing dressing in sync with the tool.

The electronic gear box is hereinafter called an EGB function.

Configuration examples of controlled axes

- Spindle : EGB master axis serving as a tool axis
- First axis : X
- Second axis : Y
- Third axis : C axis (EGB slave axis serving as a workpiece axis)
- Fourth axis : C axis (EGB dummy axis, which cannot be used as a usual controlled axis)
- Fifth axis : V axis (EGB slave axis serving as a dressing axis)
- Sixth axis : V axis (EGB dummy axis, which cannot be used as a usual controlled axis)

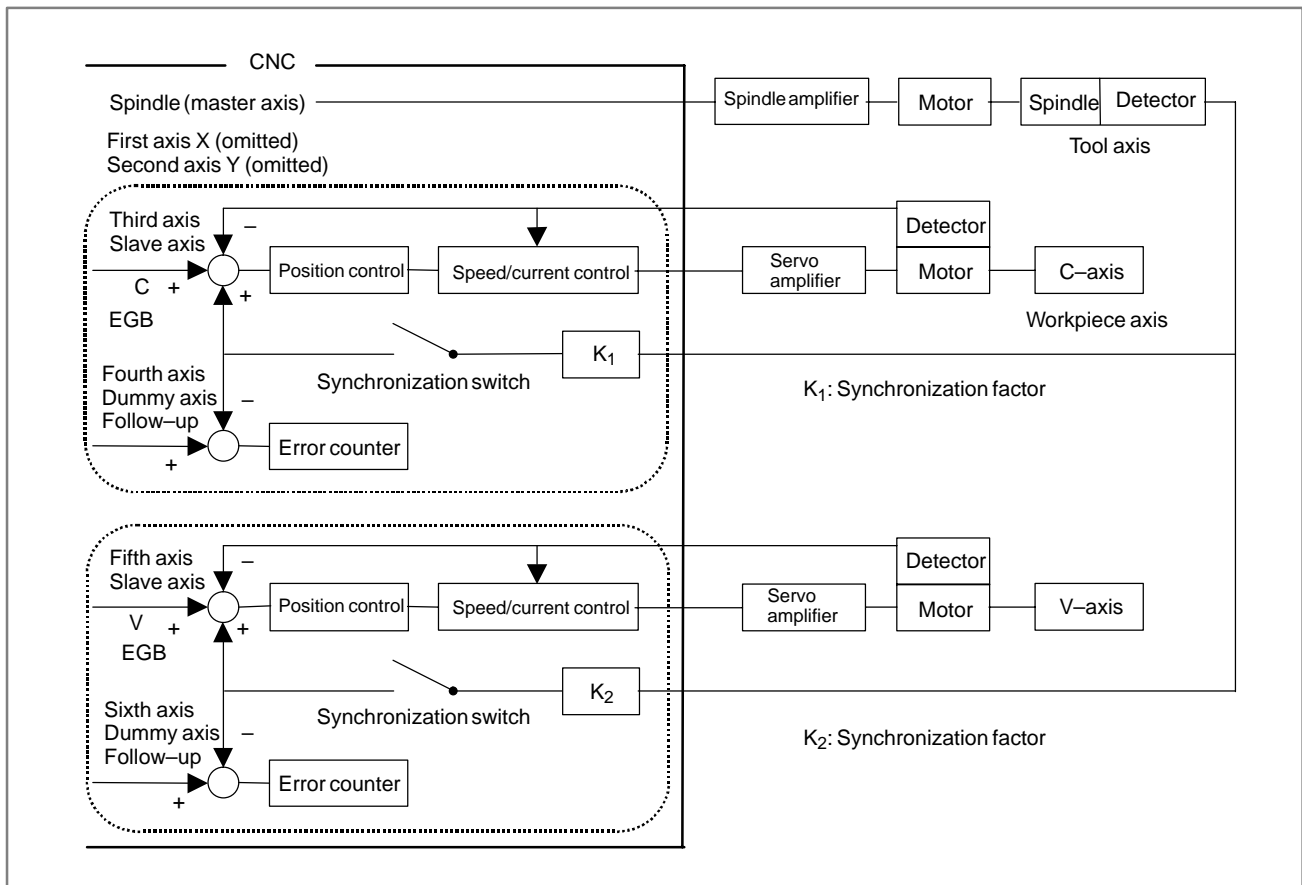

NOTE

A sampling period of 1 ms is applied when feedback pulses are read from the master axis; the synchronization pulses for a slave axis are calculated according to synchronization coefficient K; and the pulses are specified for position control of the slave axis.

Synchronization start

When the ratio of the master-axis travel to the slave-axis travel is specified, synchronization starts.

Format

$$G81.5 \quad \left\{ \begin{array}{l} Tt \\ Pp \end{array} \right\} \quad \left\{ \begin{array}{ll} \beta j & \\ \beta 0 & L1 \end{array} \right\};$$

Master-axis travel

Slave-axis travel

Specify the master-axis travel in either of the following ways.

1. Master-axis speed

T t : Master-axis speed ($1 \leq t \leq 1000$)

2. Master-axis pulse count

P p : Master-axis pulse count ($1 \leq p \leq 999999999$)

Specify a pulse count on the condition that four pulses correspond to one period in the A and B phases.

Specify the slave-axis travel in either of the following ways.

1. Slave-axis travel

β : Slave-axis address

j : Slave-axis travel indicated in units of the minimum travel increments

(the range of valid settings for usual axis movement applies)

When j = 0, the specified command is regarded as being a command for the slave-axis speed, described below. In this case, if L is not specified, an alarm is output.

2. Slave-axis speed

$\beta 0 L \pm 1$: β : Slave-axis address

1: Slave axis speed ($1 \leq l \leq 21$)

CAUTION

- 1 A move command can be issued by a program to the slave axis or other axes during synchronization. In this case, the command shall be an incremental command.
- 2 A G00, G27, G28, G29, G30, G30.1, G33 or G53 command cannot be issued to the slave axis in synchronization mode.
- 3 Controlled-axis detach cannot be used for the master axis or the slave axis.

NOTE

- 1 A manual handle interruption can be issued to the slave axis or other axes during synchronization.
- 2 The maximum feedrates for the master axis and the slave axis are limited according to the position detectors used.
- 3 An inch/metric conversion command (G20 or G21) cannot be specified in synchronization mode.
- 4 The machine coordinates for the slave/dummy axis are updated in synchronization mode.

Synchronization end

1. Canceling synchronization for each axis by issuing a command
With a G80.5 β 0 command, synchronization is canceled.
 β is the address of the slave axis. Synchronization of the slave axis specified by β is canceled.
A cancellation command can be issued only for one axis in one block.
When β 0 is not specified, the synchronization of all currently synchronized axes is canceled.
When a synchronization cancellation command is issued, the absolute coordinates for the slave axis are updated according to the amount of travel during synchronization. For a rotation axis, the value obtained by rounding off the amount of travel during synchronization to the nearest 360 degrees is added to the absolute coordinates.
2. Canceling synchronization by a reset
For an axis for which a parameter is set to allow synchronization to be canceled by a reset, HBR, bit 0 of No. 7700, is set to 0, allowing synchronization to be canceled by a reset. When a manual absolute signal is on, the absolute coordinates are updated.
3. Others
Synchronization is automatically canceled under the following conditions.
 - (1) Emergency stop
 - (2) Servo alarm
 - (3) P/S000 alarm (indicating that the power should be turned off)

Description of commands compatible with those for a hobbing machine

A command compatible with that for a hobbing machine can be used as a synchronization command.

Such a command cannot be used when a canned-cycle option is provided. Specify which axes starts synchronization with such a command by using parameter No. 7710.

(1) Synchronization start

When the following command is specified, synchronization of spindle axis and C axis starts

G81 T_(L_)(Q_P_);

T : Number of teeth (range of valid settings: 1 to 1000)

L : Number of hob threads

(range of valid settings: -200 to +200, excluding 0)

The sign of L determines the direction of rotation for the workpiece axis.

When L is positive, the direction of rotation for the workpiece axis is positive (+ direction).

When L is negative, the direction of rotation for the workpiece axis is negative (- direction).

When L is not specified, the number of hob threads is regarded as being 1.

Q : Module or diametral pitch

In metric input, specify a module

(unit : 0.00001 mm, range of valid settings : 0.1 to 25.0 mm).

In inch input, specify a diametral pitch

(unit : 0.00001 [1/inch], range of valid settings: 0.1 to 254.0 [1/inch])

P : Twisted angle of a gear

(unit : 0.00001 degrees, range of valid settings : -90.0 to 90.0 degrees)

Specify P and Q to use helical gear compensation. In this case, if only one of P and Q is specified, P/S alarm 181 is generated.

The decimal point can be specified in Q and P.

When a G81 command is issued to change to synchronization mode, the EGB mode confirmation signal for the workpiece axis becomes "1" and synchronization starts between the spindle and the workpiece axis.

During synchronization, control is performed such that the ratio of the spindle speed to the workpiece-axis speed is the same as that of T (number of teeth) to L (number of hob threads).

When a G81 command is again specified during synchronization without canceling synchronization, P/S alarm 181 is generated.

(2) Synchronization end

When the following command is specified, synchronization is cancelled.

G80 ;

Synchronization of all synchronized axes is canceled.

When a synchronization cancellation command is issued, the absolute coordinates for the slave axis are updated according to the amount of travel during synchronization.

For a rotation axis, the value obtained by rounding off the amount of travel during synchronization to the nearest 360 degrees is added to the absolute coordinates.

In a G80 block, do not specify addresses other than O or N.

(3) Helical gear compensation

For a helical gear, the workpiece axis is subjected to compensation for movement along the Z axis (axial feed axis) according to the twisted angle of the gear.

Helical gear compensation is performed with the following data.

$$\text{Compensation angle} = \frac{Z \times \sin(P)}{\pi \times T \times Q} \times 360 \text{ (In metric input)}$$

$$\text{Compensation angle} = \frac{Z \times Q \times \sin(P)}{\pi \times T} \times 360 \text{ (In inch input)}$$

where

Compensation angle: Absolute value with sign (degrees)

Z : Amount of travel along the Z axis after a G81 command is issued (mm or inch)

P : Twisted angle of the gear with sign (degrees)

π : Ratio of the circumference of a circle to its diameter

T : Number of teeth

Q : Module (mm) or diametral pitch (inch⁻¹)

Use P, T, and Q specified in the G81 block.

CAUTION

In the case with the Spindle Electron Gear Box function (Spindle EGB), the Spindle EGB synchronization is started by the G81 command of the Commands Compatible for a Hobbing Machine.

The Spindle EGB synchronization can not be started by the G81.5 command of the Electronic Gear Box 2 Pair function.

● **Compensation direction in helical gear compensation**

Parameter HDR (bit 2 of No. 7700)

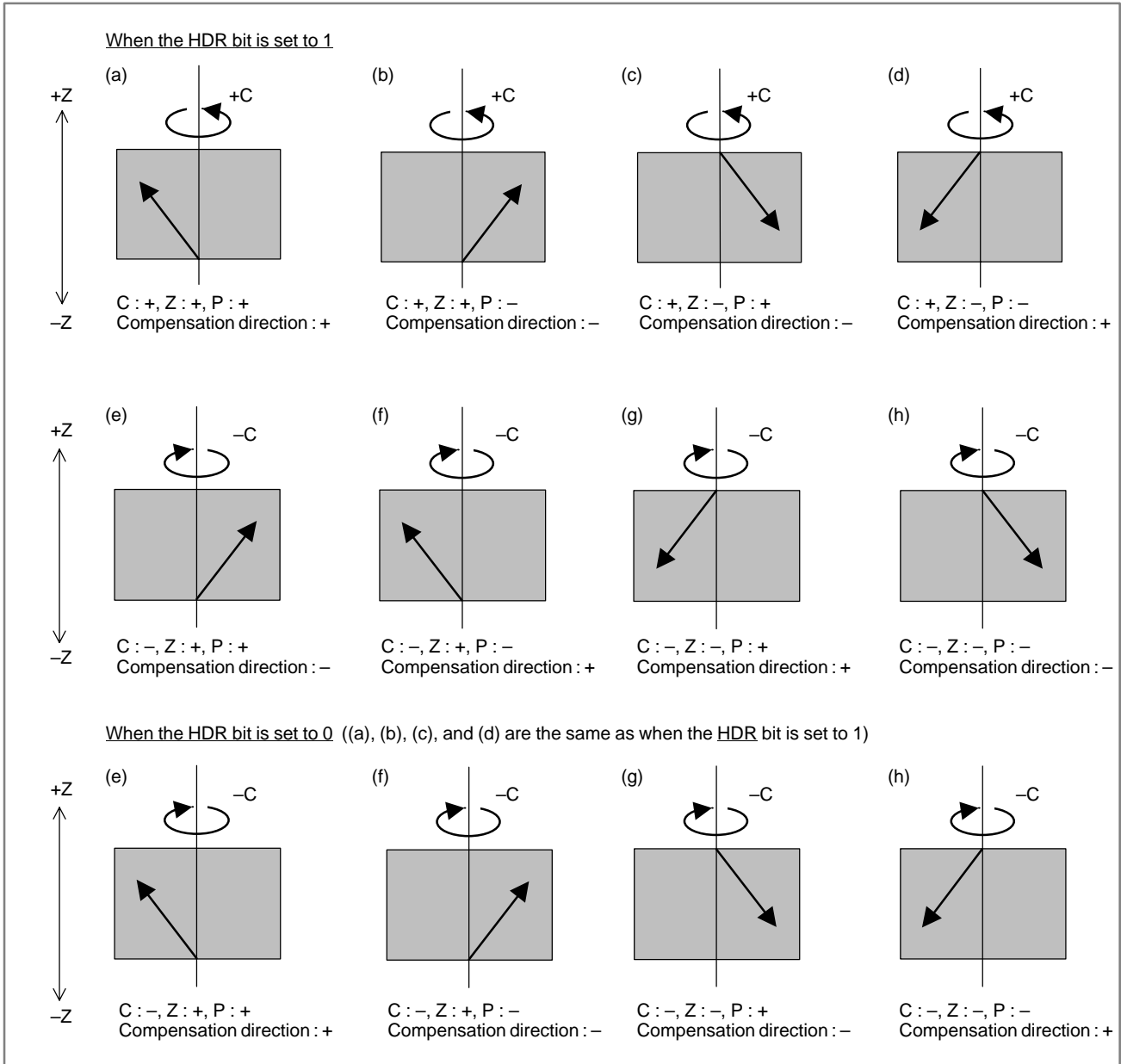

Sample programs

- (1) When the master axis is the spindle, and the slave axis is the C-axis
 1. G81.5 T10 C0 L1 ;
Synchronization between the master axis and C-axis is started at the ratio of one rotation about the C-axis to ten rotations about the master axis.
 2. G81.5 T10 C0 L-1 ;
Synchronization between the master axis and C-axis is started at the ratio of one rotation about the C-axis to ten rotations about the master axis.
In this case, however, the direction of rotation is opposite to that of 1. above.
 3. G81.5 T1 C3.26 ;
Synchronization between the master axis and C-axis is started at the ratio of a 3.26-degree rotation about the C-axis per one rotation about the master axis.
 4. G81.5 P10000 C-0.214 ;
Synchronization between the master axis and C-axis is started at the ratio of a -0.214 degree rotation about the C-axis to 10,000 feedback pulses from the pulse coder of the master axis.
- (2) When the master axis is the spindle, the slave axis is the V-axis (linear axis), and inch/metric conversion is performed
 1. For a millimeter machine and metric input
G81.5 T1 V1.0 ;
Synchronization between the master axis and V-axis is started at the ratio of a 1.00 mm movement along the V-axis per rotation about the master axis.
 2. For a millimeter machine and inch input
G81.5 T1 V1.0 ;
Synchronization between the master axis and V-axis is started at the ratio of a 1.0 inch movement (25.4 mm) along the V-axis per rotation about the master axis.

(3) When two groups of axes are synchronized simultaneously

Based on the controlled axis configuration described in Item “Configuration examples of controlled axes”, the sample program below synchronizes the spindle with the V-axis while the spindle is synchronized with the C-axis.

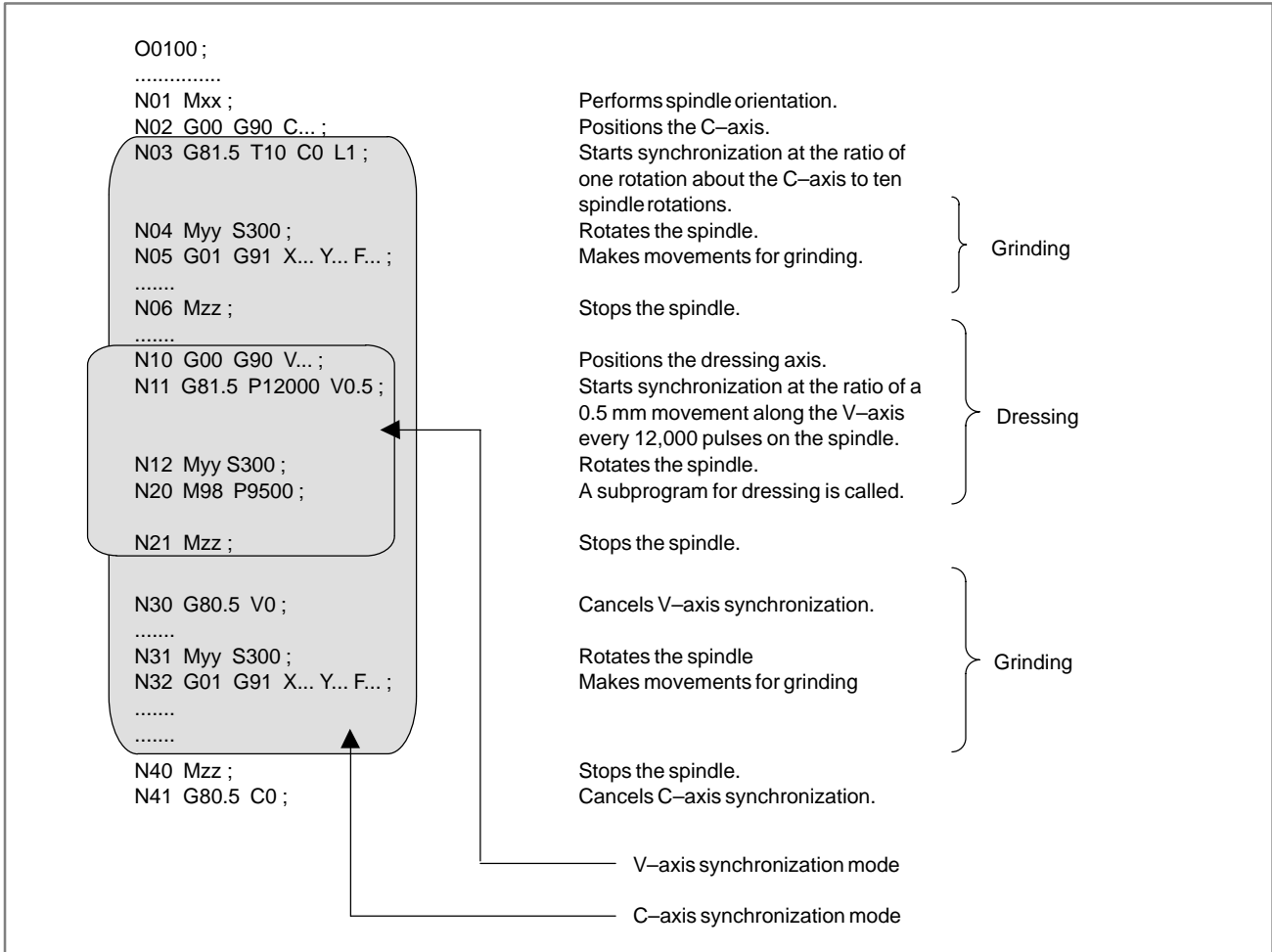

(4) Command specification for hobbing machines

Based on the controlled axis configuration described in Item “Configuration examples of controlled axes”, the sample program below sets the C-axis (in parameter 7710) for starting synchronization with the spindle according to the command specification method for hobbing machines.

O1234 ;

.....

.....

N01 G81 T20 L1 ; Starts synchronization with the spindle and C-axis at the ratio of a 1/20 rotation about the C-axis to one spindle rotation.

N02 Mxx S300 ; Rotates the spindle at 300 min⁻¹.

N03 X... F... ; Makes a movement along the X-axis (for cutting).

N04 Y... F... ; Makes a movement along the Y-axis (for grinding). Axes such as the C-axis, X-axis, and Y-axis can be specified as required.

N05 X... F... ; Makes a movement along the X-axis (for retraction).

N06 Mzz ; Stops the spindle.

N07 G80 ; Cancels the synchronization between the spindle and C-axis.

Synchronization Ratio Specification Range

The programmed ratio (synchronization ratio) of a movement along the slave axis to a movement along the master axis is converted to a detection unit ratio inside the NC. If such converted data (detection unit ratio) exceeds a certain allowable data range in the NC, synchronization cannot be established correctly, and P/S alarm 181 is issued.

Even when a programmed master axis movement and a programmed slave axis movement are within specifiable ranges, a detection unit ratio obtained by conversion can exceed the allowable range, thus resulting in an alarm.

Let K be a synchronization ratio. The internal data corresponding K is the amount of slave axis movement (K_n) represented in the detection unit divided by the amount of master axis movement (K_d) represented in the detection unit; this fraction is represented as K_n/K_d (reduced to its lowest terms) as indicated below.

$$K = \frac{K_n}{K_d} =$$

Amount of slave axis movement represented in the detection unit

Amount of master axis movement represented in the detection unit

K_n and K_d must lie within the following ranges:

$$-2147483648 \leq K_n \leq 2147483647$$

$$1 \leq K_n \leq 65535$$

When Kn or Kd exceeds its allowable range above, an alarm is issued. In conversion to the detection unit, when the CMR (command multiplication: parameter 1820) is a fraction or when inch/millimeter conversion is used, the fraction is directly converted without modification so that no error can occur in the conversion of specified amounts of movement.

During conversion, the amount of movement is multiplied by 254/100 for inch input on a millimeter machine, and 100/254 for metric input on an inch machine. Thus, Kn and Kd can become large numbers. If a synchronization ratio cannot be reduced to its lowest terms, an alarm condition is likely to occur.

Example 1)

Based on the controlled axis configuration described in 2.1., suppose that the spindle and V-axis are as follows:

Spindle pulse coder :
 72000pulse/rev (4 pulses for one A/B phase cycle)
 C-axis least command increment : 0.001 degree
 C-axis CMR : 5
 V-axis least command increment : 0.001mm
 V-axis CMR : 5

Then, the C-axis detection unit is 0.0002 degree. The V-axis detection unit is 0.0002 mm. In this case, the synchronization ratio (Kn, Kd) is related with a command as indicated below. Here, let Pm and Ps be the amounts of movements represented in the detection unit on the master axis and slave axis specified in a synchronization start command, respectively.

(1) When the master axis is the spindle, and the slave axis is the C-axis

(a) Command : G81.5 T10 C0 L1 ;

Operation : Synchronization between the spindle and C-axis is started at the ratio of one rotation about the C-axis to ten spindle rotations.

Pm : (Number of pulses per spindle rotation) × 10 rotations → 72000 × 10

Ps : (Amount of movement per rotation about the C-axis) × CMR × (one rotation) → 360000 × 5 × 1

$$\frac{Kn}{Kd} = \frac{360000 \times 5 \times 1}{72000 \times 10} = \frac{5}{2}$$

Both Kn and Kd are within the allowable range. No alarm is output.

(b) Command : G81.5 T10 C0 L-1 ;

Operation : Synchronization between the spindle and C-axis is started at the ratio of one rotation about the C-axis to ten spindle rotations.

In this case, however, the direction of rotation is opposite to that of (a) above.

Pm : (Number of pulses per spindle rotation) × 10 revolutions → 72000 × 10

Ps : (Amount of movement per rotation about the C-axis) × CMR × (one rotation) → -360000 × 5 × 1

$$\frac{Kn}{Kd} = \frac{-360000 \times 5 \times 1}{72000 \times 10} = \frac{-5}{2}$$

Both Kn and Kd are within the allowable range. No alarm is output.

(c) Command : G81.5 T1 C3.263 ;

Operation : Synchronization between the spindle and C-axis is started at the ratio of a 3.263-degree rotation about the C-axis to one spindle rotation.

Pm : (Number of pulses per spindle rotation) × 1 rotation
→ 72000 × 1

Ps : (Amount of C-axis movement) × CMR → 3263 × 5

$$\frac{Kn}{Kd} = \frac{3263 \times 5}{72000 \times 10} = \frac{3263}{14400}$$

Both Kn and Kd are within the allowable range. No alarm is output.

In this sample program, when T1 is specified for the master axis, the synchronization ratio (fraction) of the CMR of the C-axis to the denominator Kd can always be reduced to lowest terms, thus Kd falls in the allowable range. So, the specifiable range of C is as follows:

$$-99999999 \leq C \leq 99999999$$

(d) Command : G81.5 T10 C3.263 ;

Operation : Synchronization between the spindle and C-axis is started at the ratio of a 3.263-degree rotation about the C-axis to ten spindle rotations.

Pm : (Number of pulses per spindle rotation) × 10
rotations → 72000 × 10

Ps : (Amount of the C-axis movement) × CMR → 3263
× 5

$$\frac{Kn}{Kd} = \frac{3263 \times 5}{72000 \times 10} = \frac{3263}{14400}$$

In this case, an alarm is issued because Kd exceeds the specifiable range.

(e) Command : G81.5 P10000 C-0.214 ;

Operation : Synchronization between the spindle and C-axis is started at the ratio of a -0.214 degree rotation of the C-axis to 10,000 feedback pulses from the pulse coder of the spindle.

Pm : (Specified number of feedback pulses from the pulse coder of the spindle) → 10000

Ps : (Amount of C-axis movement) × CMR → -214 × 5

$$\frac{Kn}{Kd} = \frac{-214 \times 5}{10000} = \frac{-107}{1000}$$

Both Kn and Kd are within the allowable range. No alarm is output.

(2) When the master axis is the spindle, the slave axis is the V-axis (linear axis), and inch/metric conversion is performed

(a) For a millimeter machine and metric input

Command : G81.5 T1 V1.0 ;

Operation : Synchronization between the spindle and V-axis is started at the ratio of a 1.00 mm movement along the V-axis per spindle rotation.

Pm : (Number of pulses per spindle rotation) × 1 rotation
→ 72000 × 1

Ps : (Amount of V-axis movement) × CMR → 1000 × 5

$$\frac{Kn}{Kd} = \frac{1000 \times 5}{72000} = \frac{5}{72}$$

Both Kn and Kd are within the allowable range. No alarm is output.

(b) For a millimeter machine and inch input

Command : G81.5 T1 V1.0 ;

Operation : Synchronization between the spindle and V-axis is started at the ratio of a 1.0 inch movement (25.4 mm) along the V-axis per spindle rotation.

Pm : (Number of pulses per spindle rotation) × 1 revolution
→ 72000 × 1

Ps : (Amount of V-axis movement) × CMR × 254 ÷ 100
→ 10000 × 5 × 254 ÷ 100

$$\frac{Kn}{Kd} = \frac{10000 \times 5 \times 254}{72000 \times 100} = \frac{127}{72}$$

Both Kn and Kd are within the allowable range. No alarm is output.

(c) For a millimeter machine and inch input

Command : G81.5 T1 V0.0013 ;

Operation : Synchronization between the spindle and V-axis is started at the ratio of a 0.0013 inch (0.03302 mm) movement along the V-axis per spindle rotation.

Pm : (Number of pulses per spindle rotation) × 1 rotation
→ 72000 × 1

Ps : (Amount of V-axis movement) × CMR × 254 ÷ 100
→ 13 × 5 × 254 ÷ 100

$$\frac{Kn}{Kd} = \frac{13 \times 5 \times 254}{72000 \times 100} = \frac{1651}{720000}$$

In this case, an alarm is issued because Kd exceeds the specifiable range.

Example 2)

Based on the controlled axis configuration described in Item “Configuration examples of controlled axes”, suppose that the spindle and V-axis are as follows:

Spindle pulse coder :

72000 pulse/rev (4 pulses for one A/B phase cycle)

C-axis least command increment : 0.001 degree

C-axis CMR : 1/2

V-axis least command increment : 0.001mm

V-axis CMR : 1/2

Then, the C-axis detection unit is 0.002 degree. The V-axis detection unit is 0.002 mm. In this case, the synchronization ratio (K_n , K_d) is related with a command as indicated below. Here, let P_m and P_s be the amounts of movements represented in the detection unit for the master axis and slave axis specified in a synchronization start command, respectively.

(1) When the master axis is the spindle, and the slave axis is the C-axis

(a) Command : G81.5 T1 C3.263 ;

Operation : Synchronization between the spindle and C-axis is started at the ratio of a 3.263-degree rotation about the C-axis per spindle rotation.

P_m : (Number of pulses per spindle rotation) \times 1 rotation
 $\rightarrow 72000 \times 1$

P_s : (Amount of C-axis movement) \times CMR $\rightarrow 3263 \times 1 \div 2$

$$\frac{K_n}{K_d} = \frac{3263 \times 1}{72000 \times 2} = \frac{3263}{144000}$$

In this case, an alarm is issued because K_d exceeds the specifiable range.

(b) Command : G81.5 T1 C3.26 ;

Operation : Synchronization between the spindle and C-axis is started at the ratio of a 3.26-degree rotation about the C-axis per spindle rotation.

P_m : (Number of pulses per spindle rotation) \times 1 revolution
 $\rightarrow 72000 \times 1$

P_s : (Amount of C-axis movement) \times CMR $\rightarrow 3260 \times 1 \div 2$

$$\frac{K_n}{K_d} = \frac{3260 \times 1}{72000 \times 2} = \frac{163}{7200}$$

(a) causes an alarm to be output because the values cannot be abbreviated. (b) causes no alarm because the ratio of the travel distances can be abbreviated to a simple ratio.

Retraction function

When retract signal RTRCT is set to 1 (on the rising edge of the signal), retraction is performed according to the retract value set in parameter No. 7741 and the feedrate set in parameter No. 7740.

The tool does not move along an axis for which the amount of retraction is set to 0.

After retraction, retraction completion signal RTRCTF is output.

CAUTION

- 1 Retract operation is performed at the feedrate specified in parameter No. 7740.
- 2 Feed hold cannot be applied to retraction.
- 3 In this case, the feedrate override capability is disabled.

NOTE

- 1 When the retract signal goes on during automatic operation, retract operation is performed, and automatic operation is stopped.
- 2 Automatic operation cannot be performed in retraction.

Signal

Retract signal
RTRCT<G066#4>

[Classification] Input signal

[Function] Retracts along the axis specified in the parameter.

[Operation] When this signal is set to "1", the CNC operates in the following way. At the rising edge of this signal, retraction can be performed for the axis for which a retract value is set in parameter No. 7741. The retract value and retract feedrate set in parameter No. 7741 and No. 7740 are used. Upon the completion of retraction, retract completion signal RTRCTF is output. The retract signal is valid in either automatic operation mode (MEM, MDI, etc.) or manual operation mode (HND, JOG, etc.). When the retract signal is set to "1" during automatic operation, retraction is performed and automatic operation is stopped.

Retraction completion signal
RTRCTF<F065#4>

[Classification] Output signal

[Function] Reports that retraction is finished.

[Operation] This signal is set to "1" in the following case.

- When retraction is finished (movement is finished)

This signal is set to "0" in the following case.

- After retraction is finished, when a move command is issued

NOTE

When the retraction completion signal is "1," the retract signal is not accepted.

EGB mode signal SYNMOD<F065#6>

[Classification] Output signal

[Function] Reports that synchronization is being executed by EGB (G81).

[Operation] This signal is set to "1" in the following case.

- During synchronization caused by EGB

This signal is set to "0" in the following case.

- When synchronization caused by EGB is released

EGB mode confirmation signal EGBM1<F208#0>, EGBM2<F208#1>, ...

[Classification] Output signal

[Function] Reports that synchronization is being executed by EGB. This signal is output to a slave axis.

EGBM_x

x : 1 First axis synchronized by EGB

2 Second axis synchronized by EGB

3 Third axis synchronized by EGB

: :

: :

[Operation] This signal is set to "1" in the following case.

- During synchronization caused by EGB

This signal is set to "0" in the following case.

- When synchronization caused by EGB is released

Signal address

	#7	#6	#5	#4	#3	#2	#1	#0
G066				RTRCT				
F065		SYNMOD		RTRCTF				
F208	EGBM8	EGBM7	EGBM6	EGBM5	EGBM4	EGBM3	EGBM2	EGBM1

Parameters

The following table lists the parameters related to EGB.

Data number	Description																		
1006 # 0 1006 # 1	To specify a speed with L in a slave-axis amount of travel in a synchronization command, the slave axis needs to be set to a rotation axis (a parameter ROT, bit 0 of No. 1006, and a parameter ROS, bit 1 of No. 1006, need to be set to 1).																		
1023	Specify on the FSSB setting screen. In FSSB manual setting, specify one of the following cases for EGB axes. <table border="1" data-bbox="512 622 1094 752"> <thead> <tr> <th>Cases</th> <th>(1)</th> <th>(2)</th> <th>(3)</th> <th>(4)</th> <th>(5)</th> </tr> </thead> <tbody> <tr> <td>EGB slave axis</td> <td>1</td> <td>3</td> <td>5</td> <td>7</td> <td>9</td> </tr> <tr> <td>EGB dummy axis</td> <td>2</td> <td>4</td> <td>6</td> <td>8</td> <td>10</td> </tr> </tbody> </table>	Cases	(1)	(2)	(3)	(4)	(5)	EGB slave axis	1	3	5	7	9	EGB dummy axis	2	4	6	8	10
Cases	(1)	(2)	(3)	(4)	(5)														
EGB slave axis	1	3	5	7	9														
EGB dummy axis	2	4	6	8	10														
2011 #0	Specify an axis to be synchronizedSpecify 1 for both an EGB slave axis and EGB dummy axis																		
3115 # 6	The current position is not indicated for an axis for which this parameter is set to 1.Since the current position for an EGB dummy axis has no meaning, set this parameter to 1 to delete the current position indication for the axis from the CRT screen.																		
7700 #0	Specify whether synchronization mode is canceled by a reset																		
7700 #2	Compensation direction for helical gear compensation																		
7702 #3	Specify whether the retraction function is made valid by a servo or spindle alarm.																		
7709	Number of the axial feed axis in helical compensation																		
7710	Number of axis to be synchronized in a command compatible with that for a hobbing machine																		
7730 #0	Specify whether the retraction function is effective for each axis																		
7740	Retraction speed																		
7741	Retraction amount																		
7772	Number of position detector pulses per rotation about tool axis																		
7773	Number of position detector pulses per rotation about workpiece axis																		
7782	Pulse count of position detector per rotation about EGB master axis																		
7783	Pulse count of position detector per rotation about EGB slave axis																		

For details of FSSB settings, see Section 1.4.3.

If FSSB setting mode is automatic setting mode, setting is made automatically by inputting data to the FSSB setting screen. For the slave/dummy axes of EGB, set the value in the 'TANDEM' item in the FSSB axis setting screen same way of the tandem setting.

Note the following points when specifying parameters for the electronic gear box.

1. Arrange the controlled axes such that a slave axis appears before a dummy axis.

(Example)

Example of incorrect setting

Axis name	Servo axis number (No.1023)
X	1
Y	2
C (dummy axis)	3
C (slave axis)	4

Example of correct setting

Axis name	Servo axis number (No.1023)
X	1
Y	2
C (slave axis)	3
C (dummy axis)	4

2. Do not use a name which is usually not allowed to be used as an axis address, such as D.
3. Specify the same values for an EGB slave axis and an EGB dummy axis in the following parameters.
 - 1004#7 Ten times minimum input increment
 - 1001#0 Inch/metric switching (rotation axis/linear axis)
 - 1006#1 Shape of machine coordinate system (rotation axis/linear axis)
 - 1006#2 Shape of machine coordinate system for pitch error compensation (rotation axis/linear axis)
 - 1420 Rapid traverse rate
 - 1421 Rapid-traverse override F0 speed
 - 1820 Command multiplication
4. Specify the amount of travel per rotation about a rotation axis for a slave axis in a parameter No. 1260.
5. Make the specification for a dummy axis in the following way.
 - 1807#3, 1815#1 Whether to use separate detectors. Although an EGB dummy axis uses the interface of a separate detector, set these parameters to 0.
6. If the following parameters are not specified, an alarm (SV 417 servo parameter invalid) may be generated. In such a case, make the specification as described below.
 - 20XX Specify the same value for both a slave axis and a dummy axis.
 - 2084, 2085 Flexible feed gear.
Set parameters Nos. 2084 and 2085 to 1 for the dummy axis.
7. Specify as large a feed-forward coefficient as possible to reduce the synchronization error. For details of parameter setting, see Feed-forward setting of Geometric error suppression function in FANUC AC SERVO MOTOR α i series Parameter Manual (B-65270EN) or FANUC AC SERVO MOTOR α series Parameter Manual (B-65150E).

1023	Number of the servo axis for each axis
------	--

[Data type] Byte axis

[Valid data range] 1 to the maximum number of controlled axes

Specify the number of the servo axis that corresponds to each control axis. Normally, set each servo and control axis to the same numbers. For axes under electronic gear box (EGB) control, a pair of two axes must be set. Set these axes as follows:
 Set 1, 3, 5, or 7 for the slave axis. For the dummy axis to be used with the slave axis, set a value greater than the value set for the slave axis.

NOTE
 After setting this parameter, the power must be turned off then on again.

	#7	#6	#5	#4	#3	#2	#1	#0
2011								SYNMOD

[Data type] Bit axis

SYNMOD Specifies the axis on which to perform synchronization when using the electronic gear box function (EGB).

0 : Axis on which to perform synchronization with the EGB.

1 : Not an axis on which to perform synchronization with the EGB.

Set 1 for both the EGB slave and dummy axes.

	#7	#6	#5	#4	#3	#2	#1	#0
3115								NDPx

[Data type] Bit axis

NDPx Display of the current position for each axis

0 : The current position is displayed.

1 : The current position is not displayed.

NOTE
 When using the electronic gear box function (EGB), specify 1 for the dummy axis of the EGB to disable position display.

	#7	#6	#5	#4	#3	#2	#1	#0
7700						HDR		HBR

[Data type] Bit

HBR Specifies whether to cancel the synchronous mode (G81, G81.5) when the electronic gear box function (EGB) is used.

0 : Cancel upon reset.

1 : Do not cancel upon reset. The synchronous mode is canceled by the G80 or G80.5 code only.

HDR Specify the direction for compensating a helical gear. (Usually, set 1.)

Example: When the rotation direction of the C-axis is the negative (-) direction, and a left-twisted helical gear is cut:

0 : Set a negative (-) value in P.

1 : Set a positive (+) value in P.

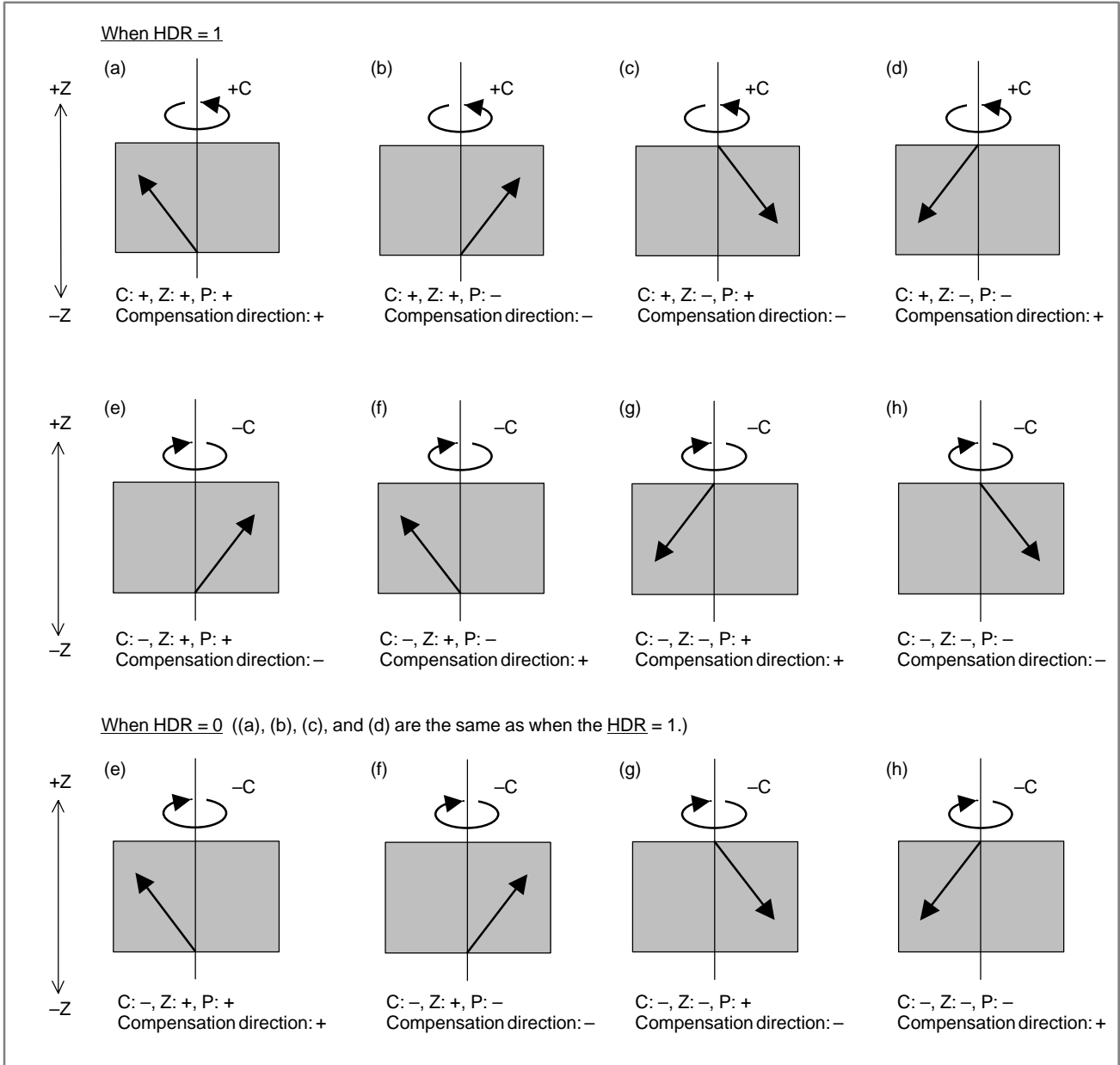

	#7	#6	#5	#4	#3	#2	#1	#0
7702					ART			

[Data type] Bit

ART Specifies whether the retraction function based on a servo spindle alarm is valid.

0 : Not valid.

1 : Valid

7709	Axial-feed axis number in helical compensation
------	--

[Data type] Byte

[Valid data range] 1 to the maximum number of controlled axes

This parameter sets the number of the axial feed axis for a helical gear. If the value out of the valid range is specified, 3 (the 3rd axis) is specified.

NOTE
After setting this parameter, the power must be turned off then on again.

7710	Axis number of an axis to be synchronized using the method of command specification for a hobbing machine
------	---

[Data type] Byte

[Valid data range] 1 to the maximum number of controlled axes

When there are several groups of axes subject to synchronization control (the axes for which bit 0 (SYNMOD) of parameter No. 2011 is set to 1), an axis with which to start synchronization is specified using the following command (for a hobbing machine):

G81 T t L ± 1 ;
 t: Spindle speed ($1 \leq t \leq 1000$)
 l: Number of synchronized axis rotations ($1 \leq l \leq 21$)

Synchronization between the spindle and a specified axis is established with the ratio of ±1 rotations about the synchronized axis to t spindle rotations.

t and l correspond to the number of teeth and the number of threads on the hobbing machine, respectively.

When only one group of axes is to be synchronized, this parameter is ignored.

NOTE
After setting this parameter, the power must be turned off then on again.

7730	#7	#6	#5	#4	#3	#2	#1	#0
								RTR

[Data type] Bit axis

RTR Specifies whether the retraction function is effective for each axis.

- 0 : Retraction is disabled.
- 1 : Retraction is enabled.

7740	Retractfeedrate
------	-----------------

[Data type] 2-word axis

[Unit of data] [Valid data range]	Increment system	Unit of data	Valid data range	
			IS-B	IS-C
	Millimeter machine	1 mm/min	30 to 240000	30 to 100000
	Inch machine	0.1 inch/min	30 to 96000	30 to 48000

This parameter sets the feedrate during retraction for each axis.

7741	Retractamount
------	---------------

[Data type] 2-word axis

[Valid data range] -99999999 to 99999999

Increment system	Unit of data	
	IS-B	IS-C
Millimeter input	0.001 mm	0.0001 mm
Inch input	0.0001 inch	0.00001 inch

This parameter sets the feedrate during retraction for each axis.

7772	Number of position detector pulses per rotation about tool axis
------	---

[Data type] 2-word

[Data unit] detection unit

[Valid data range] 1 to 999999999

Set the number of pulses from the position detector per EGB master axis rotation.

Specify this parameter with four pulses equaling one A/B phase cycle.

7773	Number of position detector pulses per rotation about workpiece axis
------	--

[Data type] 2-word

[Data unit] detection unit

[Valid data range] 1 to 999999999

Set the number of pulses from the position detector per EGB slave axis rotation.

Specify the number of pulses output by the detection unit.

7782	Number of pulses from the position detector per EGB master axis rotation
------	--

[Data type] 2-word axis

[Valid data range] 1 to 999999999

Set the number of pulses from the position detector per EGB master axis rotation.

Specify this parameter with four pulses equaling one A/B phase cycle.

7783

Number of pulses from the position detector per EGB slave axis rotation

[Data type] 2-word axis**[Data unit]** detection unit**[Valid data range]** 1 to 999999999

Set the number of pulses from the position detector per EGB slave axis rotation.

Specify the number of pulses output by the detection unit.

Alarm and message

Number	Message	Contents
P/S 181	FORMAT ERROR IN G81 BLOCK	Format error in the block in which EGB was specified (1) The axis during synchronization by EGB is specified by G81.5 again. (2) U-axis is specified by G81.5/G80.5 with U-axis control. (3) Format error in the block in which G81.5/G80.5 was specified. <ul style="list-style-type: none"> • Data is specified to more than 2 slave axes in one block. Or nothing is specified to the slave axis. • Data specified to the slave axis is neither 'β0 Lxx' nor 'βxx'. • Data is specified to more than 2 master axes in one block. • Data is specified to the axis which is neither the master nor the slave axis. • One of T, P or a codes is specified redundantly. • Out of range data is specified by one of T or L codes. • An overflow occurred during calculation of the synchronization coefficient.
P/S 184	ILLEGAL COMMAND IN G81	An illegal instruction was issued during synchronization by EGB. (1) Slave axis was specified by G00, G27, G28, G29, and G30 G codes. (2) Inch/metric conversion was specified by G20 or G21 G codes.
P/S 186	PARAMETER SETTING ERROR	Erroneous EGB parameter setting The number of pulses (parameter Nos. 7782, 7783) per rotation is not set.

1.15 FLEXIBLE SYNCHRONIZATION CONTROL (M SERIES)

General

This function is provided for machines that require synchronizing two or more different gear ratios, such as a hobbing machine.

The function can simultaneously place up to four sets in synchronization independently. For example, it is possible to realize special hobbing machine functions, such as synchronization between a hob axis and one workpiece axis, Z-C synchronization in helical gear cutting, and Y-C synchronization in hob axis shifting.

The specification of flexible synchronization control is as follows:

- 1) Master and slave axis numbers, and gear ratios are set in parameters.
- 2) These parameters are divided into four groups. So, four synchronization operations can be performed simultaneously.
- 3) The same slave axis can be specified for more than one master axis.
- 4) Synchronization is started and canceled by DI signals received from the PMC.

However, switching DI signals during an automatic operation requires using M codes specified in parameters.

- 5) Two Cs axes can be used as master and slave axes.
- 6) Retraction is possible in the same manner as for hob functions.
- 7) Using feedback pulses for the spindle that runs on the Cs axis supports feed per revolution.

The command format is G95 P_; where P_ is the Cs axis number.

Feed per minute function is included in the threading/synchronized feed option.

• Block diagram

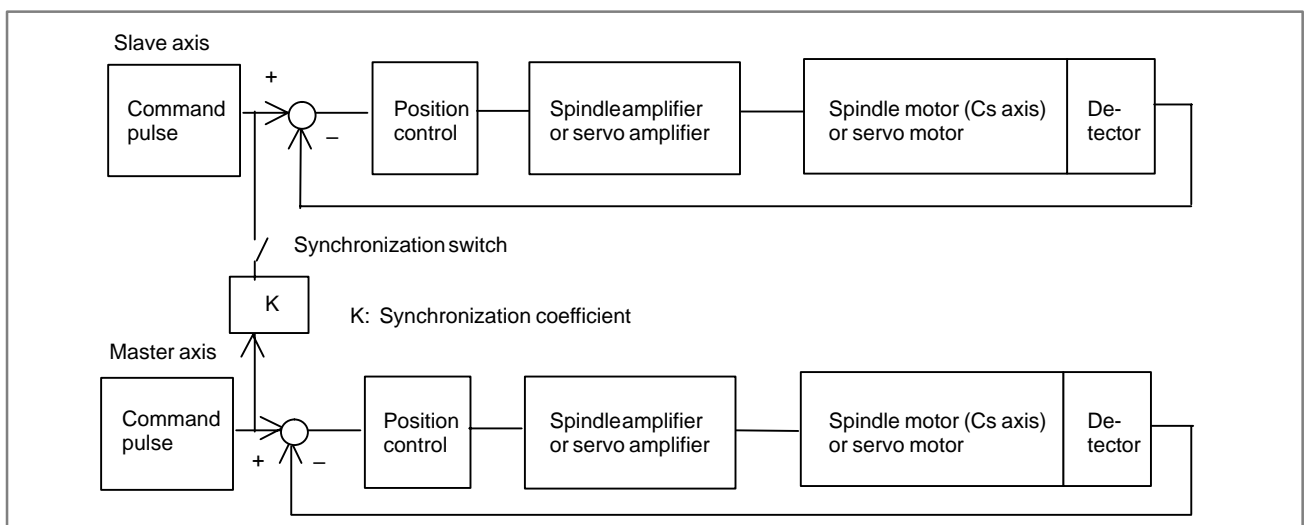

Parameter setting

The flexible synchronization control parameters are listed below:

- (1) Denominators determining gear ratios (parameter Nos. 5681, 5683, 5685, and 5687)
- (2) Numerators determining gear ratios (parameter Nos. 5680, 5682, 5684, and 5686)
- (3) Indexes to gear ratio denominators (parameter Nos. 5690, 5691, 5692, and 5693)
- (4) Master axis numbers (parameter Nos. 5660, 5662, 5664, and 5666)
- (5) Slave axis numbers (parameter Nos. 5661, 5663, 5665, and 5667)
- (6) M code numbers for turning synchronization mode ON (parameter Nos. 5670, 5672, 5674, and 5676)
- (7) M code numbers for turning synchronization mode OFF (parameter Nos. 5671, 5673, 5675, and 5677)

Starting synchronization

Flexible synchronization control is started by setting flexible synchronization control mode select signals (MTA, MTB, MTC, or MTD (G197.0, G197.1, G197.2, or G197.3)) to 1. However, setting MTA, MTB, MTC, or MTD to 1 during an automatic operation requires using an M code specified in a parameter (No. 5670, 5672, 5674, or 5676). Up to three of these M codes can be specified in one block by enabling the one-block-to-multiple-M-code command (setting bit 7 of parameter No. 3404 to 1).

When MTA, MTB, MTC, or MTD is accepted, the flexible synchronization control mode signal switching accepted signal (MFSYNA, MFSYNB, MFSYNC, or MFSYND (F197.0, F197.1, F197.2, or F197.3)) is set to 1.

Canceling synchronization

Flexible synchronization control is canceled by resetting flexible synchronization control mode select signals (MTA, MTB, MTC, or MTD (G197.0, G197.1, G197.2, or G197.3)) to 0.

When MTA, MTB, MTC, or MTD is accepted, the flexible synchronization control mode signal switching accepted signal (MFSYNA, MFSYNB, MFSYNC, or MFSYND (F197.0, F197.1, F197.2, or F197.3)) is reset to 0.

Retract function

Setting the RTRCT (G66.4) retract signal to 1 in the automatic operation mode (MEM, MDI, etc.) or in the manual operation mode (HNDL, JOG, etc.) can retract the axis specified in a parameter (bit 0 of parameter No. 7730) through a distance set in a parameter (parameter No. 7741).

NOTE

- 1 A feedrate for retraction is set in a parameter (parameter No. 7740).
Feedrate overriding is disabled, however.
- 2 Feed hold is disabled during retraction.
- 3 If the retract signal is set to 1 during an automatic operation, the automatic operation is stopped, and retraction is started.

Program example

Axis configuration of X, Y, Z, B (Cs axis), C, U, and V

Group A: Master axis B, slave axis C, gear ratio of 1:50, M50 for turning on, M51 for turning off

Group B: Master axis Z, slave axis C, gear ratio of 1:5, M52 for turning on, M53 for turning off

Group C: Master axis Y, slave axis C, gear ratio of 23:20, M54 for turning on, M55 for turning off

Group D: Master axis B, slave axis U, gear ratio of 1:100, M56 for turning on, M57 for turning off

G90 G00 X111.5 Z410.0 Y75.0 B0 C0 ;Move to the start point.

M50 ; Start B-C synchronization.

M52 ; Start Z-C synchronization.

Mxx ; Rotate the hob axis, using a constant-speed command for PMC axis control.

G04 X1000 ; Wait until the rotation speed of the hob axis becomes constant.

G00 X71.3 ; X-axis approach 1

G01 X61.2 F100 ; X-axis approach 2

G01 Z369.4 F40.0 ; Helical gear cutting

G00 X111.5 ; X-axis escape

.....
M54 ; Start Y-C synchronization.

G91 G01 Y3.0 F100.0 ; Y-axis shift

M55 ; Stop Y-C synchronization.

.....
G90 G00 U1000.0 V200.0 B0 ; Move to the dressing start point.

M56 ; Start B-U synchronization.

Mxx ; Rotate the hob axis.

G04 X1000 ; Wait until the rotation speed of the hob axis becomes constant.

G01 V100.0 ; V-axis approach

G01 U200.0 ; Dressing

G00 V200.0 ; V-axis escape

M57 ; Stop B-U synchronization

Caution

- 1) A reset does not cancel synchronization.
- 2) Synchronization is achieved even if the slave axis is in any of the following states:
 - ◆ Interlock
 - ◆ Feed hold
- 3) Synchronization is not maintained if the slave axis is in any of the following states:
 - ◆ Machine lock
 - ◆ Servo off
- 4) The master axis cannot be an RISC axis or a chopping axis.
The slave axis cannot be an RISC axis, a chopping axis, or a PMC axis.

- 5) Issuing G28, G30, G30.1 or G53 during synchronization control results in the PS010 (IMPROPER G CODE) alarm being issued. Before issuing G28, G30, G30.1 or G53, cancel synchronization control.
- 6) This function is disabled when the machine is in the RISC-based HPCC mode or when it is involved in an operation related to AI, contour control, high-speed remote buffer A or B, high-speed cycle machining, or high-speed linear interpolation.
- 7) The parameters (Nos. 5660 to 5667, 5670 to 5677, 5680 to 5687, and 5690 to 5693) can be set in a part program that uses a programmable parameter input (G10).
- 8) The display of the slave axis position may or may not be updated by synchronization pulses as follows:
 - ◆ The machine position display is updated.
(The display may appear not to be in synchronization, because update is based on post-acceleration/-deceleration a travel distance.)
 - ◆ Neither the absolute position display nor the relative position display is updated.
The absolute position display and the relative position display of the slave axis are updated by adding a synchronization-based travel distance when synchronization is canceled.
- 9) When the flexible synchronization mode is turned from off to on during an automatic operation, the PS5242 (ILLEGAL AXIS NUMBER) alarm is issued if the specified master or slave axis number is incorrect or if the slave axis number is smaller than the master axis number.
- 10) When the flexible synchronization mode is turned from off to on during an automatic operation, the PS5243 (DATA OUTFRANGE) alarm is issued if the specified gear ratio is incorrect.
- 11) When the flexible synchronization mode is turned from off to on or on to off during an automatic operation, the PS5244 (TOO MANY DI ON) alarm is issued if the mode signal does not become on or off after an M code is executed.
- 12) If the flexible synchronization control mode is already or just entered, the PS5245 (OTHER AXIS ARE COMMANDED) alarm is issued in any of the following cases:
 - ◆ Both the master axis and its slave axis, which is in synchronization with the master axis, happen to be the same EGB axis.
 - ◆ Both the master axis and its slave axis, which is in synchronization with the master axis, happen to be the same chopping axis.
 - ◆ The reference position return mode is entered (or has been entered).
- 13) If an SV alarm condition occurs, the flexible synchronization mode is automatically turned off after deceleration to a stop.
- 14) The output pulse for the slave axis is generated by multiplying the frequency of the detection-unit output pulse for the master axis by the gear ratio.

- 15) If the spindle is synchronized with the servo motor, it is necessary to cause the loop gain of the servo motor to match that of the spindle in order to make their positional deviations equal.
- 16) The actual speed display does not take synchronization pulses into account.

Parameter

5660	Master axis number (group A)
5661	Slave axis number (group A)
5662	Master axis number (group B)
5663	Slave axis number (group B)
5664	Master axis number (group C)
5665	Slave axis number (group C)
5666	Master axis number (group D)
5667	Slave axis number (group D)

Parameter input

[Data type] Byte

[Valid data range] 1 to 8

Specify both master and slave axis numbers.

The set values must satisfy: Master axis number \leq slave axis number

5670	M code number for turning on the flexible synchronization control mode (group A)
5671	M code number for turning off the flexible synchronization control mode (group A)
5672	M code number for turning on the flexible synchronization control mode (group B)
5673	M code number for turning off the flexible synchronization control mode (group B)
5674	M code number for turning on the flexible synchronization control mode (group C)
5675	M code number for turning off the flexible synchronization control mode (group C)
5676	M code number for turning on the flexible synchronization control mode (group D)
5677	M code number for turning off the flexible synchronization control mode (group D)

Parameter input

[Data type] Word

[Valid data range] 1 to 999

Specify an M code for turning on or off the flexible synchronization control mode for an automatic operation.

5680	Numerator determining gear ratio for flexible synchronization (group A)
5681	Denominator determining gear ratio for flexible synchronization (group A)
5682	Numerator determining gear ratio for flexible synchronization (group B)
5683	Denominator determining gear ratio for flexible synchronization (group B)
5684	Numerator determining gear ratio for flexible synchronization (group C)
5685	Denominator determining gear ratio for flexible synchronization (group C)
5686	Numerator determining gear ratio for flexible synchronization (group D)
5687	Denominator determining gear ratio for flexible synchronization (group D)

Parameter input

[Data type] Doubleword

[Valid data range] -99999999 to 99999999

Specify a gear ratio between the master and slave axes.

5690	Index to gear ratio denominator for flexible synchronization (group A)
5691	Index to gear ratio denominator for flexible synchronization (group B)
5692	Index to gear ratio denominator for flexible synchronization (group C)
5693	Index to gear ratio denominator for flexible synchronization (group D)

Parameter input

[Data type] Byte

[Valid data range] 0 to 8

Specify an index to the denominator of a gear ratio between the master and slave axes.

Let p, q, and k be, respectively, a denominator determining gear ratio for flexible synchronization, numerator determining gear ratio for flexible synchronization, and index to the gear ratio denominator for flexible synchronization:

The gear ratio is $\frac{q}{p \times 10^k}$

Signal

Flexible synchronization control mode select signals MTA, MTB, MTC, and MTD<G197#0 to #3>

[Classification] Input signal

[Function] Select flexible synchronization control.

- [Operation]**
- 1) Synchronization is started by setting these signals to 1.
 - 2) Synchronization is canceled by resetting these signals to 0.
 - MTA: Selects synchronization for group A.
 - MTB: Selects synchronization for group B.
 - MTC: Selects synchronization for group C.
 - MTD: Selects synchronization for group D.

Flexible synchronization control mode select signal switching accepted signals MFSYNA, MFSYNB, MFSYNC, and MFSYND <F197#0 to #3>

[Classification] Output signal

[Function] Check that the group selected using a flexible synchronization control mode select signal has actually been switched to the corresponding mode.

- [Operation]**
- 1) When a synchronization mode is actually enabled, the corresponding signal becomes 1.
 - 2) When a synchronization mode is actually canceled, the corresponding signal becomes 0.
 - MFSYNA: Synchronization select switching for group A has been accepted.
 - MFSYNB: Synchronization select switching for group B has been accepted.
 - MFSYNC: Synchronization select switching for group C has been accepted.
 - MFSYND: Synchronization select switching for group D has been accepted.

Signal address

	#7	#6	#5	#4	#3	#2	#1	#0
G197					MTD	MTC	MTB	MTA
F197					MFSYND	MFSYNC	MFSYNB	MFSYNA

Note**NOTE**

In flexible synchronization mode, reference position return cannot be performed.

If REF mode is set, the warning message MODE ERROR is displayed.

1.16 GENERAL PURPOSE RETRACT

General

When the retract signal RTRCT is turned to "1" (the rising edge is detected) in auto mode or manual mode, the axis set in bit 0 (RTR) of the parameter No.7730 moves (retracts) by the amount set in the parameter No.7741.

Upon the completion of retraction, the retract completion signal RTRCTF is output.

- Feedrate in retract is set to the parameter No.7740. Then the feedrate override is not effective.
- During the movement in retract, feed hold is not effective.
- In case that retract signal is turned to "1" in auto mode, the movement of the auto mode is feed hold state and the retract movement is done.
- The retract completion signal is turned to "0" when any retract axis is moved.

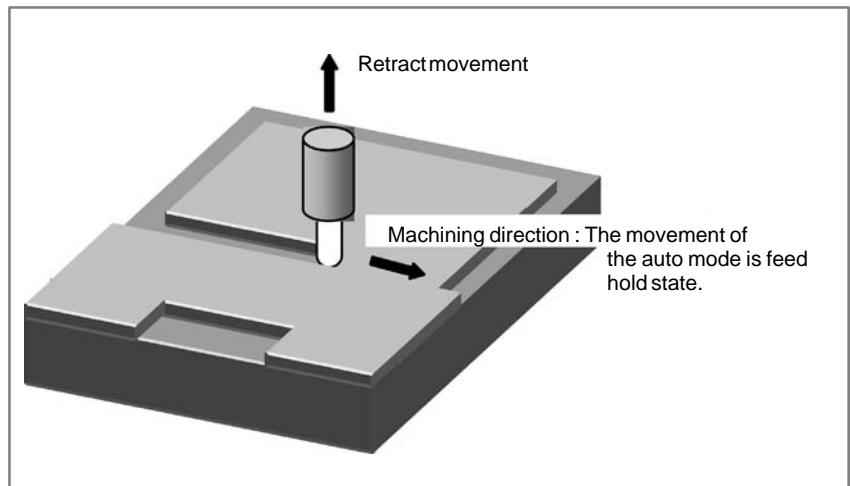

This function is used, for example, to prevent the damage of tool or workpiece when unexpected disturbance occurs during machining, and so on.

Timing chart

(1) ON/OFF timing of RTRCT and RTRCTF signals

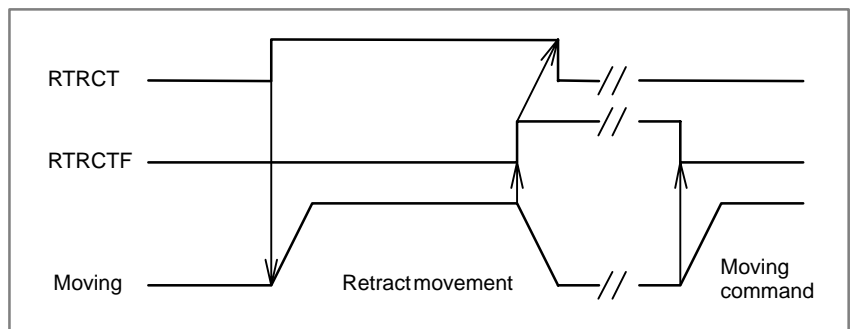

(2) The stopping of retract by the reset

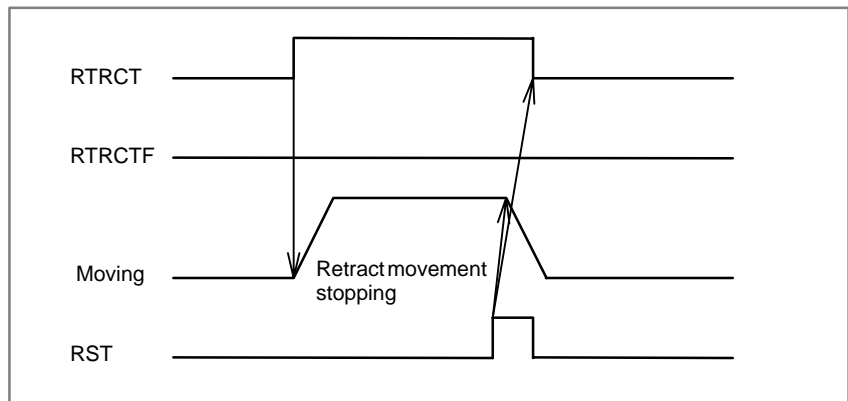
**Signal****Retract signal RTRCT**
<G066#4>**[Classification]** Input signal**[Function]** Performs retraction for the axis specified with a parameter.**[Operation]** When this signal turns to "1", the control unit performs the following:
Detects the rising edge of this signal, and performs retraction on the axis specified with bit 0 (RTRx) of parameter No.7730. The retract speed and amount of retraction are specified with parameter Nos.7740 and 7741. The retract signal is effective both in automatic operation mode and manual operation mode. When the retract signal turns to "1" during automatic operation, retraction is performed and the CNC enters feed hold state.**Retract completion**
signal RTRCTF
<F065#4>**[Classification]** Output signal**[Function]** Posts notification of the completion of retraction.**[Operation]** The signal becomes "1" when :

- Upon the completion of retraction.
In case that there are two or more retract axes, upon the completion of retraction of all retract axes.

The signal becomes "0" when :

- Upon the completion of retraction, when one of the retract axis is specified after that.

Signal address

	#7	#6	#5	#4	#3	#2	#1	#0
G066				RTRCT				
	#7	#6	#5	#4	#3	#2	#1	#0
F065				RTRCTF				

Parameter

	#7	#6	#5	#4	#3	#2	#1	#0
7730								RTRx

[Data type] Bit axis

RTRx The retract function is :

- 0 : Disabled.
- 1 : Enabled.

7740	Feedrate during retraction for each axis
------	--

[Data type] 2 Words axis

[Unit of data]	Increment system	Unit of data	Valid data range	
			IS-B	IS-C
[Valid data range]	Millimeter machine	1 mm/min	30 to 240000	30 to 100000
	Inch machine	0.1 inch/min	30 to 96000	30 to 48000

This parameter sets the feedrate during retraction for each axis

7741	Retracted distance for each axis
------	----------------------------------

[Data type] 2 Words axis

[Unit of data]	Increment system	Unit of data	
		IS-B	IS-C
	Millimeter input	0.001 mm	0.0001 mm
	Inch input	0.0001 inch	0.00001 inch

[Valid data range] -99999999 to 99999999

This parameter sets the retracted distance for each axis

Notes

- (1) Feedrate override is not supported for retracting.
- (2) Interlock is supported for retracting.
- (3) Machine lock is supported for retracting. Retract completion signal is output when retract operation is completed in the machine lock condition.
- (4) Feed hold is not supported for retracting.
- (5) The mirror image (the signal or the setting) is invalid. Therefore, the direction of retract is the direction of the machine coordinate. (The mirror image is valid for update of the absolute coordinate.)
- (6) When retract is executed during automatic operation, the control unit enters the feed hold state at the same time as the retract operation starts.
- (7) The acc./dec. of retract is the condition of the acc./dec. at retract execution.
- (8) Retract operation stops, when Reset or Emergency-stop is executed during retract movement. At this time, the retract completion signal is not turned to "1".
- (9) When the servo alarm or the OT alarm of the retract axis occurs during retract movement, retract operation stops. At this time, the retract completion signal is not turned to "1". However, when an alarm except the OT alarm or the servo alarm occurs, retract operation does not stop.
- (10) Even if the retract signal RTRCT is turned to "0" after retract operation starting, retract operation does not stop.
- (11) The retract signal RTRCT is not accepted while the retract completion signal RTRCTF is set to "1".
- (12) Even if thread cutting is executed, retract is effective. When the retract signal is input, the thread cutting operation is stopped at once and retract operation is executed.
- (13) Even if the retract is executed to the axis controlled by PMC, the movement command for the PMC axis is not canceled. In this case, the PMC axis must be canceled by the PMC axis reset signal ECLRg at the same time as the retract signal RTRCT is turned to "1".
- (14) During advanced preview control mode, high-precision contour control mode (in machining center series), or AI contour control mode (in machining center series), this function is not used.
- (15) This function is not used in high-speed cycle cutting or binary operation. In case of high-speed cycle cutting or binary operation, the retract function for each function has to be used.

2 PREPARATIONS FOR OPERATION



2.1 EMERGENCY STOP

General

If you press Emergency Stop button on the machine operator's panel, the machine movement stops in a moment.

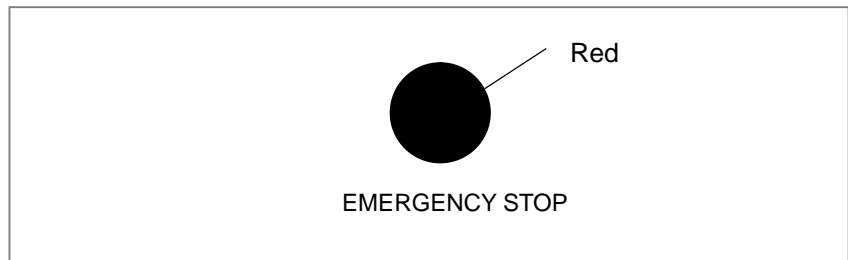

Fig. 2.1 (a) EMERGENCY STOP

This button is locked when it is pressed. Although it varies with the machine tool builder, the button can usually be unlocked by twisting it.

Signal

Emergency stop

*ESP<X008#4,G008#4>

[Classification] Input signal

[Function] Activating an emergency stop signal stops the machine instantly.

[Operation] When the emergency stop signal *ESP turns to "0", the emergency stop is applied to the machine and the CNC is reset. This signal is controlled by the B contacts of a pushbutton switch. The emergency stop signal turns the servo ready signal (SA) to "0".

Overtravel detection by this CNC is handled by the stored stroke check function, and a limit switch for normal overtravel detection is not needed. To prevent the machine from moving beyond the software limit through servo feedback error, always install a stroke end limit switch (shown in Fig. 2.1 (b) as follows).

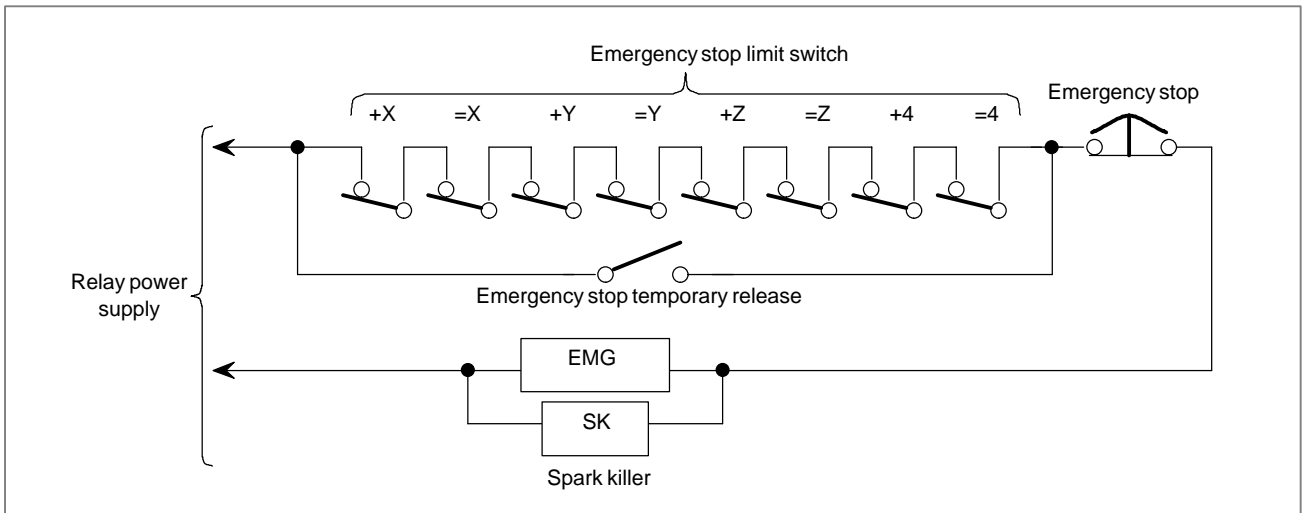

Fig. 2.1 (b) Connection of emergency stop limit switch

The distance from the position where the dynamic brake is applied to that where the tool stops moving is given in the “AC Servo Motor Descriptions.”

WARNING

Software limit setting point and operating point of limit switch for emergency stop

The stop point by the software limit goes beyond the setting point by as much as the following distance.

$$\frac{R}{7,500} \text{ (mm)}$$

R: Rapid traverse rate (mm/min)

The actual stopping point may exceed the position set by a parameter (Nos.1320 and 1321) by as much as R/7500 (mm). Set the limit switch for emergency stop including the allowance for the above value.

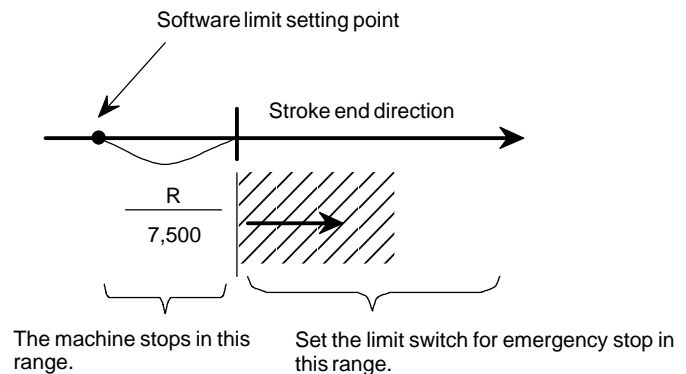

Signal address

	#7	#6	#5	#4	#3	#2	#1	#0
X008				*ESP				
G008				*ESP				

Reference item

FANUC AC SERVO MOTOR α series DESCRIPTIONS	B-65142E
FANUC AC SERVO MOTOR αi series DESCRIPTIONS	B-65262EN

2.2 CNC READY SIGNAL

General

When the CNC is turned on and becomes ready for operation, the CNC ready signal is set to 1.

Signal

CNC Ready Signal MA<F001#7>

[Classification] Output signal

[Function] The CNC ready signal indicates that the CNC is ready.

[Output condition] When the CNC is turned on and becomes ready for operation, the signal is set to 1. Normally, it takes several seconds to establish this state after the power is turned on. If a system alarm is issued, the signal is set to 0. The signal remains set to 1, however, when an emergency stop or a similar operation is performed.

Servo Ready Signal SA <F000#6>

[Classification] Output signal

[Function] Signal SA turns to “1” when the servo system is ready to operate. For an axis that is to be braked, release the brake when this signal is “1” and apply the brake when this signal is “0”.

Time chart of this signal is as follows:

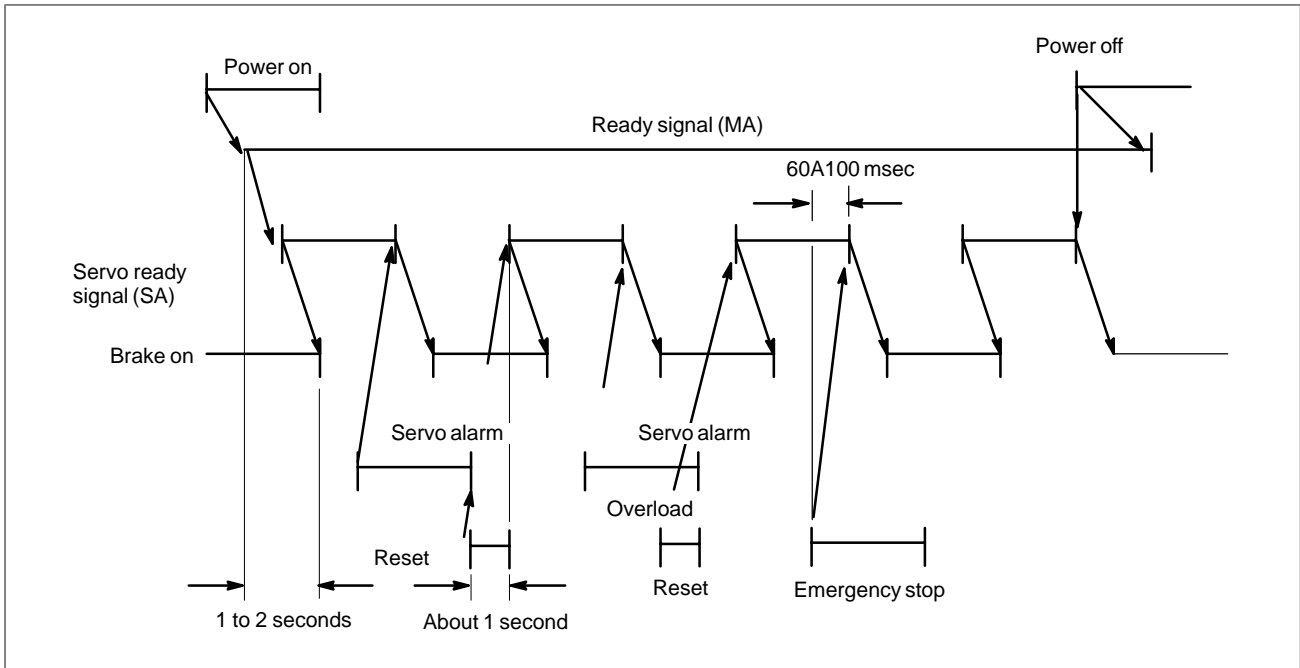

Fig. 2.2 Time chart for servo ready signal

Signal address

	#7	#6	#5	#4	#3	#2	#1	#0
F000		SA						
	#7	#6	#5	#4	#3	#2	#1	#0
F001	MA							

2.3 OVERTRAVEL CHECK

2.3.1 Overtravel Signal

General

When the tool tries to move beyond the stroke end set by the machine tool limit switch, the tool decelerates and stops as a result of tripping the limit switch, and an OVER TRAVEL is displayed.

Signal

Overtravel signal

*+L1 to *+L8<G114>

*+L1 to *-L8<G116>

[Classification] Input signal

[Function] Indicates that the control axis has reached its stroke limit. There are individual signals for each direction in every control axis. The +/- in the signal name indicates the direction and the number corresponds to the control axis.

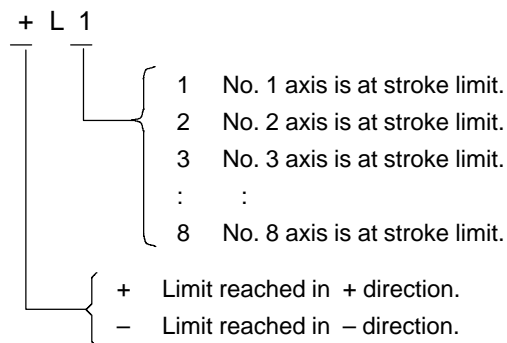

[Operation] When it is “0”, the control unit operates as given below.

- In automatic operation, if even one axis overtravel signal turns to “0”, all axes are decelerated to stop, an alarm is given and operation is halted.
- In manual operation, only the axis whose overtravel signal has turned to “0” is decelerated to a stop, and the axis can be moved in the opposite direction.
- Once the axis overtravel signal has turned to “0”, the axis direction is registered. Even if the signal returns to “1”, it is not possible to move that axis in that direction until the alarm is cleared.

The following shows the deceleration distance at overtravel.

(i) Rapid traverse

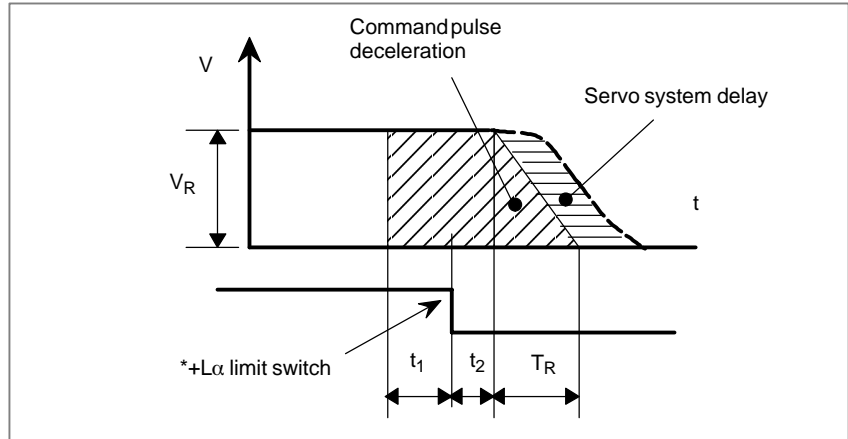

$$L_1 = V_R \left(t_1 + t_2 + \frac{T_R}{2} + T_S \right) \cdot \frac{1}{60000} \text{ [mm or inch]}$$

L_1 : Deceleration distance

V_R : Rapid traverse speed (mm/min or inch/min)

t_1 : Limit switch signal delay time (from limit switch operation to $*+L\alpha$ signal turn off (ms))

t_2 : Receiver delay time 30ms

T_R : Rapid traverse acceleration/deceleration time constant (ms)

T_S : Servo system time constant (ms)

NOTE

Servo system time constant T_S is 33 msec when the servo unit is adjusted to the standard setting.

(ii) Cutting feed

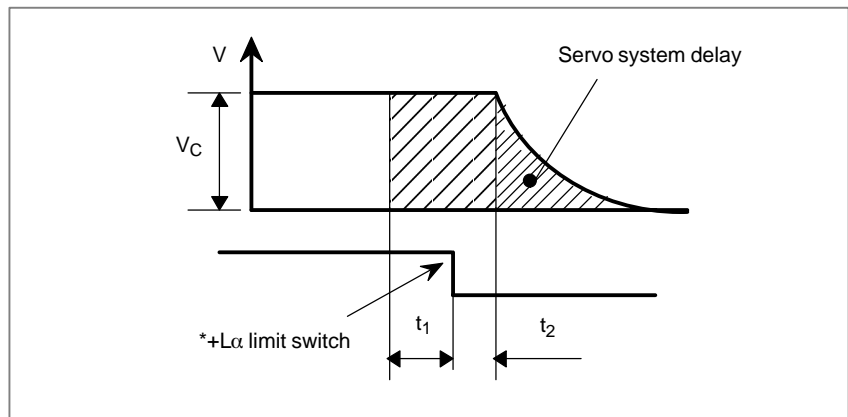

$$L_2 = V_C \left(t_1 + t_2 + \frac{T_R}{2} + T_S \right) \cdot \frac{1}{60000} \text{ [mm or inch]}$$

L_2 : Deceleration distance

V_C : Maximum feedrate (mm/min or inch/min)

t_1, t_2, T_S : Same as (i).

- **Releasing overtravel**

First, move the tool into a safe zone under manual operation. Then press the reset button to reset the alarm.

Signal address

	#7	#6	#5	#4	#3	#2	#1	#0
G114	*+L8	*+L7	*+L6	*+L5	*+L4	*+L3	*+L2	*+L1
G116	*-L8	*-L7	*-L6	*-L5	*-L4	*-L3	*-L2	*-L1

Parameter

	#7	#6	#5	#4	#3	#2	#1	#0
3004			OTH					

[Data type] Bit

OTH The overtravel signal is:

0 : Checked

1 : Not checked

WARNING

For safety, set to 0 at checking.

Alarm and message

Number	Message	Description
506	OVER TRAVEL : +n	Tool has moved beyond overtravel limit of the n-th axis in positive direction.
507	OVER TRAVEL : -n	Tool has moved beyond overtravel limit of the n-th axis in negative direction.

Reference item

Series 16i/18i/160i/180i/ 160is/180is	OPERATOR'S MANUAL (For Machining Center) (B-63534EN)	III.6.2	Overtravel
	OPERATOR'S MANUAL (For Lathe) (B-63524EN)	III.6.2	Overtravel
Series 21i/210i/210is	OPERATOR'S MANUAL (For Machining Center) (B-63614EN)	III.6.2	Overtravel
	OPERATOR'S MANUAL (For Lathe) (B-63604EN)	III.6.2	Overtravel

2.3.2 Stored Stroke Check 1

General

When the tool tries to moved beyond a stored stroke check limit, an alarm is displayed and the tool is decelerated and stopped.

When the tool enters a forbidden zone and an alarm is generated, the tool may only be moved in the direction from which the tool came.

Parameters (Nos. 1320, 1321 or Nos. 1326, 1327) define the boundary. The forbidden zone lies outside the defined check limits. The machine tool builder usually sets this zone to permit maximum stroke.

The parameters used for stroke check can be switched by a signal.

Parameters can be used to change the stroke check method as follows (M series only):

- For a manual operation, setting both the BFA (bit 7 of No. 1300) and OTF (bit 5 of No. 1301) parameters to 1 causes an alarm to be issued on the border of the forbidden area and the machine to stop accordingly.
- For a manual operation, setting the NAL (bit 1 of No. 1300) to 1 causes the stroke limit reached signals +OT1 to +OT8 and –OT1 to –OT8 <F124 and F126> to be output without detecting an alarm condition.

Automatic alarm releasing

Setting the OF1 (bit 4 of No. 1301) parameter to 1 causes an alarm to be released when the axis enters a movable range without using a reset.

Signal

Stored stroke check select signal EXLM <G007#6>

[Classification] Input signal

[Function] Selects stroke check 1–I (parameter Nos. 1320 and 1321) or stroke check 1–II (parameter Nos. 1326 and 1327).

[Operation] When this signal is set to 1, the control unit operates as follows:
– Checks stroke check 1 on the basis of parameter Nos. 1326 and 1327, instead of parameter Nos. 1320 and 1321.

NOTE

If the bit 0 (DLM) of parameter No.1301 is set to 1, this signal is disabled.

**Axis direction dependent
stored stroke limit
switch signal
+EXL1 to +EXL8<G104>
-EXL1 to -EXL8<G105>**

[Classification] Input signal

[Function] Switches between stroke limit 1-I (parameter No. 1320 and No. 1321) and stroke limit 1-II (parameter No. 1326 and No. 1327) for each axis direction.

[Operation] When this signal goes 1 while DLM (bit 0 of parameter No. 1301) is held to 1, the control unit operates as described below.

(1) +EXL1 to +EXL8 <G104>

Stroke limit 1 (+ side) is checked using parameter No. 1326 instead of No. 1320.

(2) -EXL1 to -EXL8 <G105>

Stroke limit 1 (- side) is checked using parameter No. 1327 instead of No. 1321.

NOTE

- 1 Avoid switching this signal in the high-precision contour control mode.
- 2 If the bit 0 (DLM) of parameter No.1301 is set to 1, the stored stroke limit switch signal EXLM<G007#6> is disabled.

**Stroke check external
setting signals +LM1 to
+LM8 <G110> and -LM1
to -LM8 <G112> (M
series)**

[Classification] Input signal

[Function] Change the values of the parameters governing the stroke check (1320 and 1321).

[Operation] When these signals are set to 1, the control unit operates as follows:
- Change the stored checks, set with parameter Nos. 1320 and 1321, to the machine coordinates when the signals are input.

**Stroke check release
signal RLSOT <G007#7>
(M series)**

[Classification] Input signal

[Function] Selects whether the stored stroke check 1 limits are checked or not.

[Operation] When this signal is set to 1, the control unit operates as follows:
- Does not check the stored stroke check 1 limits.

Stroke limit reached signals

+OT1 to +OT8 <F124>

-OT1 to -OT8 <F126>

(M series)

[Classification] Output signal

[Function] Notify that the tool is about to enter the forbidden area of stored stroke check 1. Each direction of each controlled axis has one stroke limit reached signal. The algebraic sign +/- in the signal name corresponds to the direction of each controlled axis, and the number at the end of the signal name represents the related controlled-axis number.

[Operation] If the tool has gone beyond the border of stored stroke check 1, the signal corresponding to the related axis direction becomes 1. Moving the tool in the opposite direction to put it back within the border (movable range) turns the signal to 0. When the tool is within the border (movable range), a reset turns the signal to 0.

CAUTION

- 1 The stroke limit reached signal is output when the NAL (bit 1 of No. 1300) parameter is 1. It is not output when the parameter is 0.
- 2 If the BFA (bit 7 of No. 1300) is 1, the tool does not go beyond the border even if a movement command that attempts to drive the tool beyond the border is issued. Instead, the tool stops rather inside the border (or, if the OTF (bit 5 of No. 1301) parameter is 1, on the border). Also in this case, the stroke limit reached signal becomes 1.

Signal address

	#7	#6	#5	#4	#3	#2	#1	#0
G007	RLSOT	EXLM						
G104	+EXL8	+EXL7	+EXL6	+EXL5	+EXL4	+EXL3	+EXL2	+EXL1
G105	-EXL8	-EXL7	-EXL6	-EXL5	-EXL4	-EXL3	-EXL2	-EXL1
G110	+LM8	+LM7	+LM6	+LM5	+LM4	+LM3	+LM2	+LM1
G112	-LM8	-LM7	-LM6	-LM5	-LM4	-LM3	-LM2	-LM1
F124	+OT8	+OT7	+OT6	+OT5	+OT4	+OT3	+OT2	+OT1
F126	-OT8	-OT7	-OT6	-OT5	-OT4	-OT3	-OT2	-OT1

Parameter

	#7	#6	#5	#4	#3	#2	#1	#0
1300	BFA	LZR				LMS	NAL	

[Data type] Bit

NAL Specifies whether to issue an alarm related to stored stroke check 1, as follows:

0 : To issue an alarm.

1 : Not to issue an alarm; the stroke limit reached signal F124 or F126 is output (for a manual operation).

LMS The EXLM signal for switching stored stroke check 1

0: Disabled

1: Enabled

LZR Checking of stored stroke check 1 during interval between power-on and setting the manual position reference return

0: The stroke check 1 is checked.

1: The stroke check 1 is not checked

NOTE

When the absolute-position detector is being used, and the reference position is already set at power-on, the stored stroke check is checked immediately after the power is turned on, regardless of the setting of this bit.

BFA When a command is issued where the resulting motion would exceed the value of stored stroke check 1 or 3

0: An alarm is generated after the stroke check 1, 3 is exceeded.

1: An alarm is generated before the stroke check 1, 3 is exceeded.

	#7	#6	#5	#4	#3	#2	#1	#0
1301			OTF	OF1				DLM

[Data type] Bit

DLM Axis direction dependent stored stroke limit switch signals +EXL1 to +EXL8 and -EXL1 to -EXL8 <G104 and G105> are

0: Disabled.

1: Enabled

OF1 If the tool is moved into the range allowed on the axis after an alarm is generated by stored stroke check 1,

0: The alarm is not canceled before a reset is made.

1: The OT alarm is immediately canceled.

CAUTION

In the cases below, the automatic release function is disabled. To release an alarm, a reset operation is required.

- 1 When a setting is made to issue an alarm before a stored stroke limit is exceeded (bit 7 (BFA) of parameter No. 1300)
- 2 When an another overtravel alarm (such as stored stroke check 2, stored stroke check 3, and interference check) is already issued
- 3 When an overtravel alarm is already issued with the high-precision contour control function or the chopping function in the M series

OTF Specifies whether to change the specification of the stored stroke check, as follows:

0 : Not to change.

1 : To change as stated below.

- If the BFA (bit 7 of No. 1300) parameter is 1, stored stroke check 1 for a manual operation causes the axis to stop on the border and an alarm to be issued.
- If the BFA (bit 7 of No. 1300) parameter is 1, stored stroke check 2 causes an alarm to be issued just before the stroke check is passed through.

1320	Coordinate value l of stored stroke check 1 in the positive direction on each axis
1321	Coordinate value l of stored stroke check 1 in the negative direction each axis

[Data type] Two-word axis

[Unit of data]	Increment system	IS-A	IS-B	IS-C	Unit
	Metric input	0.01	0.001	0.0001	mm
	Inch input	0.001	0.0001	0.00001	inch
	Rotation axis	0.01	0.001	0.0001	deg

[Valid data range] – 99999999 to 99999999

Define the coordinate values of stored stroke checks 1 in the positive and negative directions for each axis in the machine coordinate system. For each axis, travel beyond the defined limits is prohibited.

WARNING

- 1 For axes with diameter specification, a diameter value must be set.
- 2 When the parameters are set as follows, the stroke becomes infinite:
parameter 1320 < parameter 1321
For movement along the axis for which infinite stroke is set, only incremental commands are available. If an absolute command is issued for this axis, the absolute register may overflow, and normal movement will not result.

1326	Coordinate value II of stored stroke check 1 in the positive direction on each axis
1327	Coordinate value II of stored stroke check 1 in the negative direction each axis

[Data type] Two-word axis

[Unit of data]	Increment system	IS-A	IS-B	IS-C	Unit
	Metric input	0.01	0.001	0.0001	mm
	Inch input	0.001	0.0001	0.00001	inch
	Rotation axis	0.01	0.001	0.0001	deg

[Valid data range] – 99999999 to 99999999

Define the coordinate values of stored stroke checks 1 in the positive and negative directions for each axis in the machine coordinate system.

When stroke check switching signal EXLM is ON, stroke checks are checked with parameters 1326 and 1327, not with parameters 1320 and 1321. For each axis, travel beyond the defined limits (parameter Nos. 1326 and 1327) is prohibited.

NOTE

The EXLM signal is enabled only when LMS, #2 of parameter 1300, is set to 1.

Alarm and message

Number	Message	Description
500	OVER TRAVEL : +n	Tool has moved beyond overtravel limit of n-th axis (n: 1 to 8) in positive direction stored stroke check 1
501	OVER TRAVEL : -n	Tool has moved beyond overtravel limit of n-th axis (n: 1 to 8) in negative direction stored stroke check 1

Caution

CAUTION

By setting the same value for both check limits of a given axis, the entire axis become restricted.

Note**NOTE**

- 1 Parameter LZR (bit 6 of No. 1300) selects whether each check becomes effective after the power is turned on and manual reference position return or automatic reference position return by G28 has been performed or immediately after the power is turned on.
- 2 For the 2-path control, set a forbidden area for each path.
- 3 Parameter BFA (bit 7 of No. 1300) selects whether an alarm is displayed immediately before the tool enters the forbidden area or immediately after the tool has entered the forbidden area.

Reference item

Series 16i/18i/160i/180i/ 160is/180is	OPERATOR'S MANUAL (For Machining Center) (B-63534EN)	III.6.3	Stroke check
	OPERATOR'S MANUAL (For Lathe) (B-63524EN)	III.6.3	Stroke check
Series 21i/210i/210is	OPERATOR'S MANUAL (For Machining Center) (B-63614EN)	III.6.3	Stroke check
	OPERATOR'S MANUAL (For Lathe) (B-63604EN)	III.6.3	Stroke check
Series 20i	OPERATOR'S MANUAL (For Manual Milling Machine) (B-64204EN)	III.6.3	Stroke check
	OPERATOR'S MANUAL (For Manual Lathes) (B-64194EN)	III.6.3	Stroke check

2.3.3 Stored Stroke Check 2, 3

General

Three areas which the tool cannot enter can be specified with stored stroke check 1, stored stroke check 2, and stored stroke check 3.

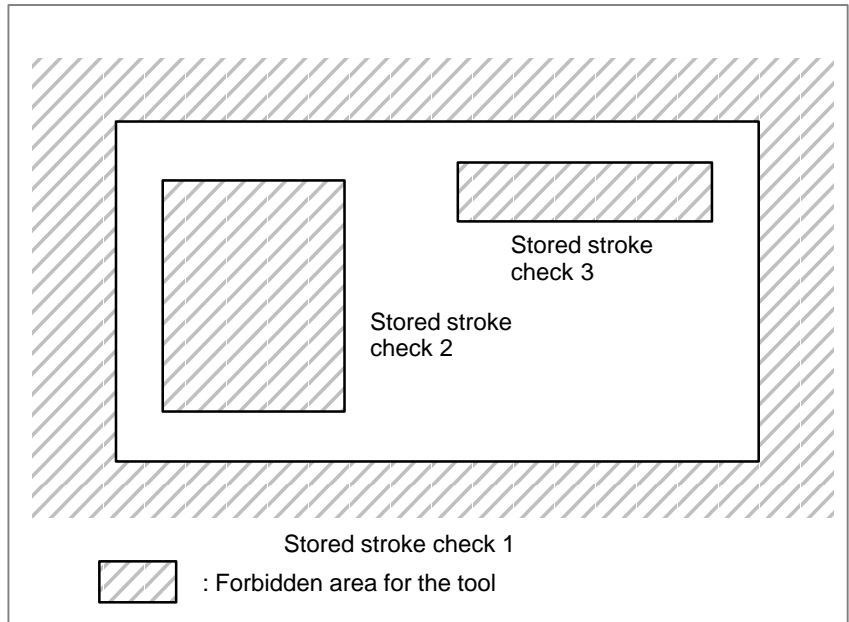

Fig. 2.3.3 (a) Stroke check (T series)

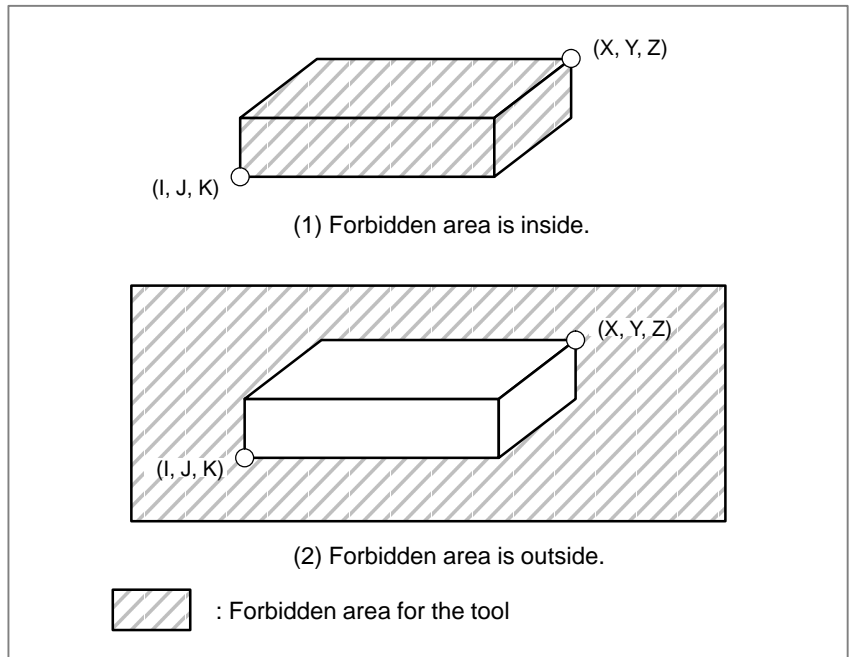

Fig. 2.3.3 (b) Stroke check (M series)

When the tool tries to move beyond a stored stroke check limit, an alarm is displayed and the tool is decelerated and stopped.

When the tool enters a forbidden area and an alarm is generated, the tool may only be moved in the direction from which the tool came.

Stored stroke check 2

The stored stroke check 2 values are set either by parameters (Nos. 1322, 1323) or by command. The forbidden area may be defined as the area external to the limits, or internal to the limits. This is determined by the value in parameter OUT (No. 1300#0). A G22 command forbids the tool to enter the forbidden area, and a G23 command permits the tool to enter the forbidden area. G22 and G23 should be commanded independently of any other commands in a block.

Setting both the BFA (bit 7 of No. 1300) and OTF (bit 5 of No. 1301) parameters to 1 can issue an alarm just before the forbidden area is entered (M series only).

The command below creates or changes the forbidden area:

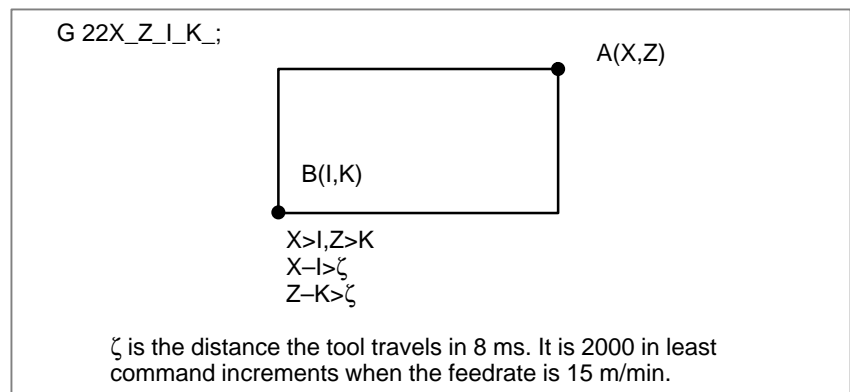

Fig. 2.3.3 (c) Creating or changing the forbidden area using a program (T series)

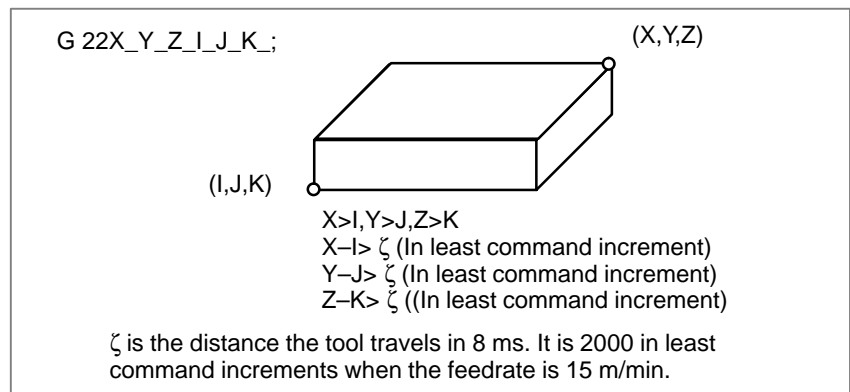

Fig. 2.3.3 (d) Creating or changing the forbidden area using a program (M series)

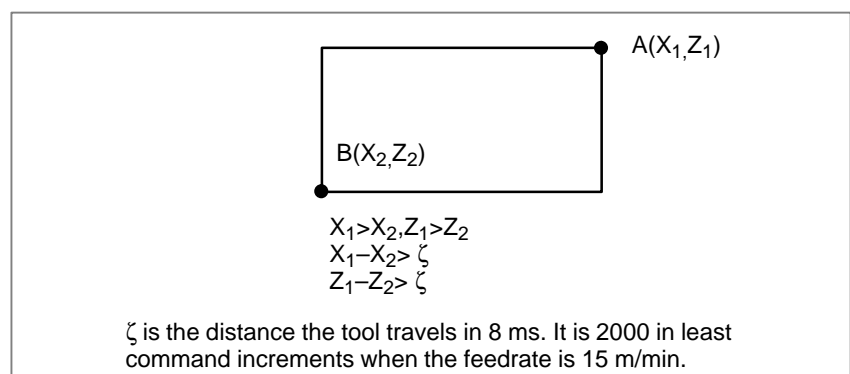

Fig. 2.3.3 (e) Creating or changing the forbidden area using parameters (T series)

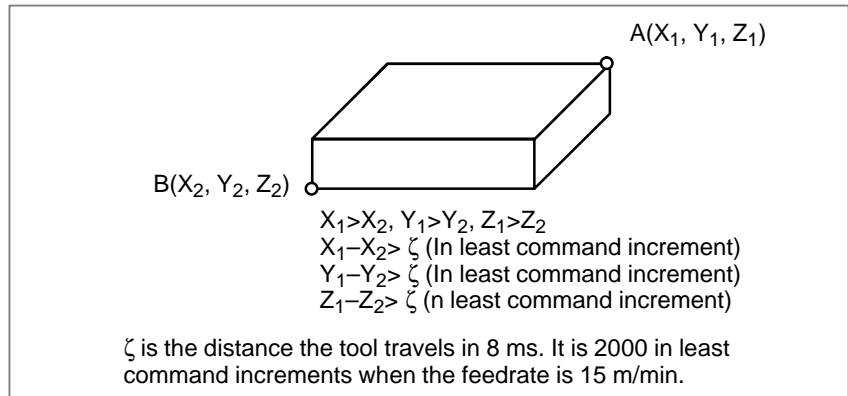

Fig. 2.3.3 (f) Creating or changing the forbidden area using parameters (M series)

When setting the forbidden area X_1, Y_1, Z_1, X_2, Y_2 and Z_2 by parameters, specify the data as the distance from the reference position in units of the least command increment (output increment).

When setting the forbidden area X, Y, Z, I, J, K (X, Z, I, K , on T series) by a G22 command, specify the data as the distance from the reference position in units of the least input increment (input increment). The programmed data are then converted into the numerical values in the least command increment, and the values are set as the parameters.

- **Stored stroke check 3**
- **Checkpoint for the forbidden area**

Define the boundary with parameters Nos. 1324 and 1325. The area inside the boundary becomes the forbidden area.

The parameter setting or programmed value (XZIK) depends on which part of the tool or tool holder is checked for entering the forbidden area. Confirm the checking position (the top of the tool or the tool chuck) before programming the forbidden area.

If point C (The tip of the tool) is checked in Fig. 2.3.3 (g), the distance “c” should be set as the data for the stored stroke check function. If point D (The tool chuck) is checked, the distance “d” must be set.

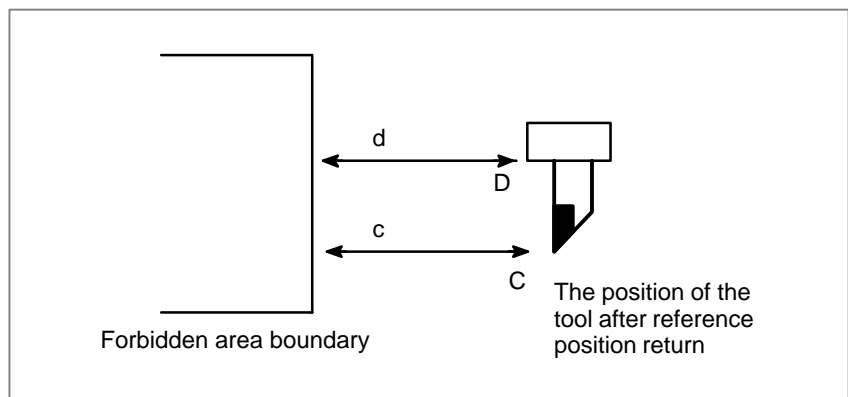

Fig. 2.3.3 (g) Setting the forbidden area (T series)

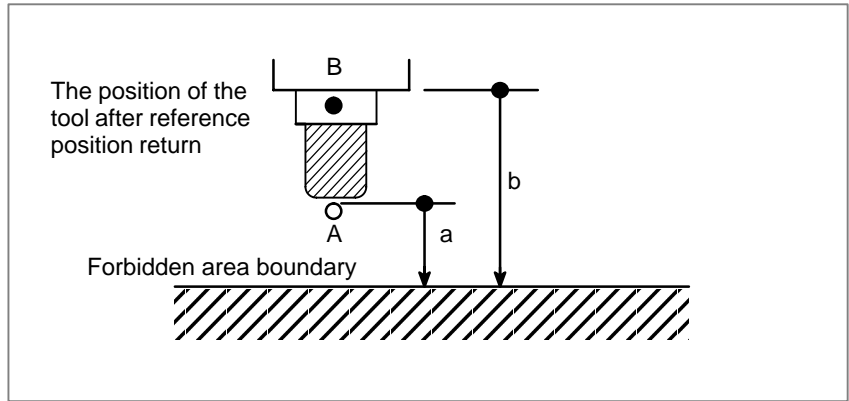

Fig. 2.3.3 (h) Setting the forbidden area (M series)

• **Forbidden area overlapping**

Forbidden areas can be set to overlap.

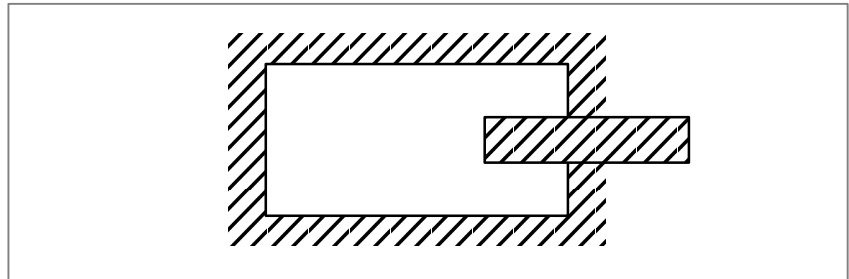
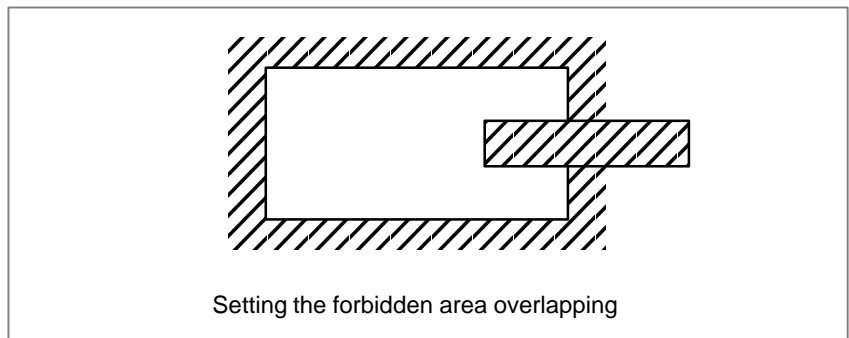

Fig. 2.3.3 (i) Setting the forbidden area overlapping (T series)

Unnecessary checks should be set beyond the machine stroke.



Setting the forbidden area overlapping

Fig. 2.3.3 (j) Setting the forbidden area overlapping (M series)

• **Effective time for a forbidden area**

Parameter LZR (bit 6 of No. 1300) selects whether each check becomes effective after the power is turned on and manual reference position return or automatic reference position return by G28 has been performed or immediately after the power is turned on.

After the power is turned on, if the reference position is in the forbidden area of each check, an alarm is generated immediately (Only in G22 mode for stored stroke check 2).

• **Releasing the alarms**

When the tool enters and forbidden area and an alarm is generated, the tool may only be moved in the direction from which the tool came. First move the tool out of the forbidden area, then clear the alarm by reset. If successfully cleared, the tool may be moved in both paths.

- **Change from G23 to G22 in a forbidden area**

When G23 is switched to G22 while the tool is in a forbidden area, the following results.

- (1) When the forbidden area is internal to the limits, an alarm is generated in the next move.
- (2) When the forbidden area is external to the limits, an alarm is generated immediately.

- **Creating the forbidden area for the 2-path control**

For the 2-path control, set a forbidden area for each tool post.

Signal

Stroke check 3 release signal RLSOT3

<G007#4>

[Classification] Input signal

[Function] Selects whether stored stroke check 3 is checked.

[Use] When this signal is set to 1, the control unit operates as follows:

- The control unit does not check stored stroke check 3.

Signal address

	#7	#6	#5	#4	#3	#2	#1	#0
G007				RLSOT3				

Parameter

	#7	#6	#5	#4	#3	#2	#1	#0
1300	BFA	LZR	RL3					OUT

[Data type] Bit

OUT The area inside or outside of the stored stroke check 2 is set as a restricted area.

0: Inside

1: Outside

RL3 Stroke check 3 release signal RLSOT3

0: The signal is disabled.

1: The signal is enabled.

LZR Checking of stored stroke check 1 during the time from power-on to the manual position reference return

0: The stroke check 1 is checked.

1: The stroke check 1 is not checked

NOTE

When the absolute-position detector is being used, and the reference position is already set at power-on, the stored stroke check is checked immediately after the power is turned on, regardless of the setting of this bit.

BFA When a command is issued where the resulting motion would exceed the value of a stored stroke check 1, 3

0: An alarm is generated after the stroke check 1, 3 is exceeded.

1: An alarm is generated before the stroke check 1, 3 is exceeded.

	#7	#6	#5	#4	#3	#2	#1	#0
1301			OTF					

[Data type] Bit

OTF Defines whether to change the specification of the stored stroke check, as follows:

0 : Not to change.

1 : To change as stated below.

- If the BFA (bit 7 of No. 1300) parameter is 1, stored stroke check 1 for a manual operation causes the axis to stop on the border and an alarm to be issued.
- If the BFA (bit 7 of No. 1300) parameter is 1, stored stroke check 2 causes an alarm to be issued just before the stroke check is passed through.

	#7	#6	#5	#4	#3	#2	#1	#0
1310							OT3x	OT2x

[Data type] Bit axis

OT2x Defines whether stored stroke check 2 is checked for each axis is set.

0: Stored stroke check 2 is not checked.

1: Stored stroke check 2 is checked.

OT3x Defines whether stored stroke check 3 is checked for each axis is set.

0: Stored stroke check 3 is not checked.

1: Stored stroke check 3 is checked.

1322	Coordinate value of stored stroke check 2 in the positive direction on each axis
------	--

1323	Coordinate value of stored stroke check 2 in the negative direction on each axis
------	--

[Data type] Two-word axis

[Unit of data]	Increment system	IS-A	IS-B	IS-C	Unit
	Metric input	0.01	0.001	0.0001	mm
	Inch input	0.001	0.0001	0.00001	inch
	Rotation axis	0.01	0.001	0.0001	deg

[Valid data range] – 99999999 to 99999999

Defines the coordinate values of stored stroke checks 2 in the positive and negative directions for each axis in the machine coordinate system. OUT, #0 of parameter 1300, sets either the area outside or the area inside specified by two checks as the inhibition area.

WARNING

For axes with diameter specification, a diameter value must be set.

1324	Coordinate value of stored check 3 in the positive direction on each axis
1325	Coordinate value of stored stroke check 3 in the negative direction on each axis

[Data type] Two-word axis

[Unit of data]	Increment system	IS-A	IS-B	IS-C	Unit
	Metric input	0.01	0.001	0.0001	mm
	Inch input	0.001	0.0001	0.00001	inch
	Rotation axis	0.01	0.001	0.0001	deg

[Valid data range] – 99999999 to 99999999

Defines the coordinate values of stored stroke checks 3 in the positive and negative directions for each axis in the machine coordinate system. For each axis, travel within the area defined by the check limits is prohibited.

Alarm and message

Number	Message	Description
502	OVER TRAVEL : +n	Tool has moved beyond overtravel limit of n-th axis in positive direction stored stroke check 2. (Parameter No.1322)
503	OVER TRAVEL : -n	Tool has moved beyond overtravel limit of n-th axis in negative direction stored stroke check 2. (Parameter No.1323)
504	OVER TRAVEL : +n	Tool has moved beyond overtravel limit of n-th axis in positive direction stored stroke check 3. (Parameter No.1324)
505	OVER TRAVEL : -n	Tool has moved beyond overtravel limit of n-th axis in negative direction stored stroke check 3. (Parameter No.1325)

Warning**WARNING**

- 1 Whenever the two check limits are set to the same value, the following results are seen.
 - (1) In the case of stored stroke check 1, all areas are prohibited.
 - (2) In the case of stored stroke check 2 or 3, no areas are prohibited.
- 2 Whenever the value of the negative limit is greater than the value of the positive limit, the following results are seen.
 - (1) In the case of stored stroke check 1, no areas are prohibited.
 - (2) In the case of stored stroke check 2 or 3, the prohibited area will consist of a quadrangle formed with the two points acting as vertices.

Note**NOTE**

Parameter BFA (bit 7 of No. 1300) selects whether an alarm is displayed immediately before the tool enters the forbidden area or immediately after the tool has entered the forbidden area. (check 1, 3 only)

Reference item

Series 16i/18i/160i/180i/ 160is/180is	OPERATOR'S MANUAL (For Machining Center) (B-63534EN)	III.6.3	Stroke check
	OPERATOR'S MANUAL (For Lathe) (B-63524EN)	III.6.3	Stroke check
Series 21i/210i/210is	OPERATOR'S MANUAL (For Machining Center) (B-63614EN)	III.6.3	Stroke check
	OPERATOR'S MANUAL (For Lathe) (B-63604EN)	III.6.3	Stroke check
Series 20i	OPERATOR'S MANUAL (For Manual Milling Machine) (B-64204EN)	III.6.3	Stroke check

2.3.4 Chuck/Tailstock Barrier (T series)

General

The chuck/tailstock barrier function prevents damage to the machine by checking whether the tool tip interferes with either the chuck or tailstock. Specify an area into which the tool may not enter (entry-prohibition area). This is done using the special setting screen, according to the shapes of the chuck and tailstock. If the tool tip should enter the set area during a machining operation, this function stops the tool and outputs an alarm message.

The tool can be removed from the prohibited area only by retracting it in the direction from which the tool entered the area.

Signal

Tailstock barrier select signal *TSB <G060#7>

[Classification] Input signal

[Function] Enables or disables the tailstock barrier.

[Operation] When this signal is set to 1, the control unit operates as follows:

- Disables the tailstock barrier, even when the G22 command (stored stroke check on) is specified in the program.

G code	*TSB	Tailstock barrier	Chuck barrier
G22	0	Enabled	Enabled
	1	Disabled	Enabled
G23	0	Disabled	Disabled
	1	Disabled	Disabled

When the G23 command (stored stroke check off) is specified, the tailstock barrier is disabled regardless of the *TSB signal. When the G22 command (stored stroke check on) is specified, the tailstock can be disabled by setting the signal to 1.

This signal is used to select whether the tailstock area is a prohibited area. It is used whenever M commands are applied, resulting in the tailstock being attached to the workpiece or detached from the workpiece while the workpiece is being machined.

Signal address

	#7	#6	#5	#4	#3	#2	#1	#0
G060	*TSB							

Parameter● **Profile of a chuck**

1330	Profile TY of a chuck
------	-----------------------

[Data type] Byte

[Valid data range] 0 or 1

0 : Chuck which holds a workpiece on the inner surface

1 : Chuck which holds a workpiece on the outer surface

(*) See Fig. 2.3.4 (a) for the figures.

1331	Dimensions of the claw of a chuck (L)
------	---------------------------------------

1332	Dimensions of the claw of a chuck (W)
------	---------------------------------------

1333	Dimensions of the part of a claw at which a workpiece is held (L1)
------	--

1334	Dimensions of the part of a claw at which a workpiece is held (W1)
------	--

[Data type] Two-word

[Unit of data]	Increment system	IS-B	IS-C	Unit
	Metric input	0.001	0.0001	mm
	Inch input	0.0001	0.00001	inch

[Valid data range] – 99999999 to 99999999

1335	X coordinate of a chuck (CX)
------	------------------------------

1336	ZX coordinate of a chuck (CZ)
------	-------------------------------

[Data type] Two-word

[Unit of data]	Increment system	IS-B	IS-C	Unit
	Metric input	0.001	0.0001	mm
	Inch input	0.0001	0.00001	inch

[Valid data range] – 99999999 to 99999999

Specify the profile of a chuck.

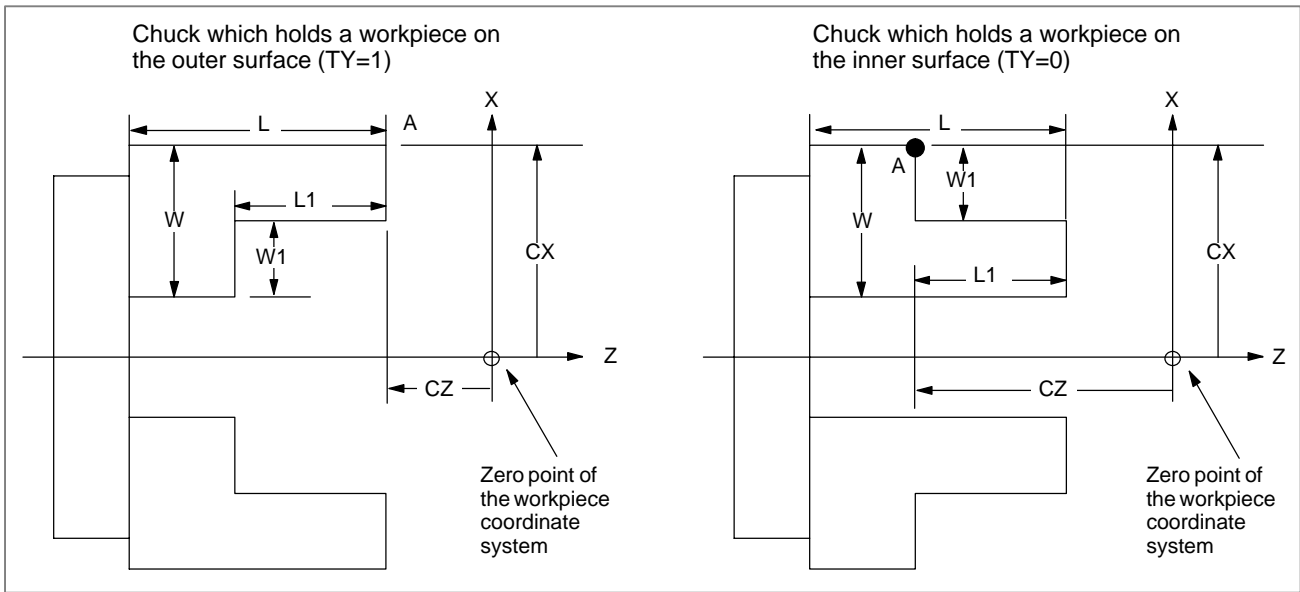

Fig. 2.3.4 (a)

Symbol	Description
TY	Profile of a chuck (0: Chuck which holds a workpiece on the inner surface, 1: Chuck which holds a workpiece on the outer surface)
CX	X coordinate of a chuck
CZ	Z coordinate of a chuck
L	Dimensions of the claw of a chuck
W	Dimensions of the claw of a chuck (radius input)
L1	Dimensions of the part of a claw at which a workpiece is held
W1	Dimensions of the part of a claw at which a workpiece is held (radius input)

TY: Specifies the profile of a chuck. When TY is set to 0, the chuck holding a workpiece on the inner surface is specified. When TY is set to 1, the chuck holding a workpiece on the outer surface is specified. The profile of the chuck is assumed to be symmetrical with respect to the z-axis.

CX, and CZ: Specify the position (point A) of a chuck with the coordinates of the workpiece coordinate system. In this case, do not use the coordinates of the machine coordinate system.

WARNING

Specifying the coordinates with a diameter or radius depends on whether the corresponding axis conforms to diameter or radius specification. When the axis conforms to diameter specification, the coordinates are specified with a diameter.

L, L1, W, and W1: Define the profile of a chuck.

WARNING

Always specify W and W1 with radii. L and L1 are also specified with radii whenever the Z-axis conforms to a radius specification.

1341	Length of a tailstock (L)
1342	Diameter of a tailstock (D)
1343	Length of a tailstock (L1)
1344	Diameter of a tailstock (D1)
1345	Length of a tailstock (L2)
1346	Diameter of a tailstock (D2)
1347	Diameter of the hole of a tailstock (D3)

[Data type] Two-word

Increment system	IS-B	IS-C	Unit
Millimeter machine	0.001	0.0001	mm
Inch machine	0.0001	0.00001	inch

[Valid data range] 0 to 99999999

1348	Z coordinate of a tailstock (TZ)
------	----------------------------------

[Data type] Two-word

Increment system	IS-B	IS-C	Unit
Millimeter machine	0.001	0.0001	mm
Inch machine	0.0001	0.00001	inch

[Valid data range] -99999999 to 99999999

Specify the profile of a tailstock.

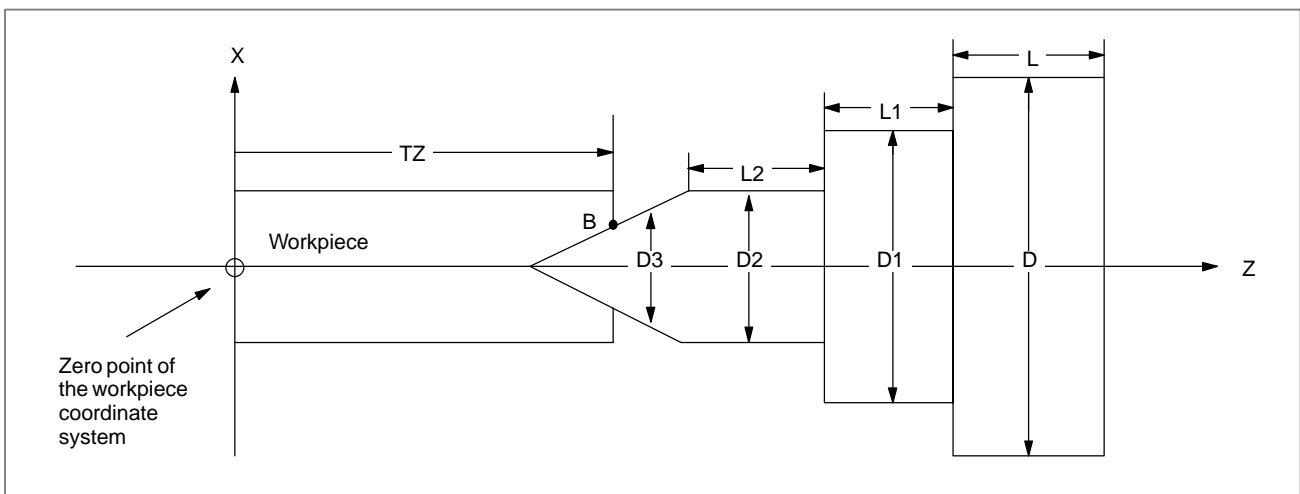

Fig. 2.3.4 (b)

Symbol	Description
TZ	Z-axis coordinate of a tailstock
L	Length of a tailstock
D	Diameter of a tailstock (diameter input)
L1	Length of a tailstock (1)
D1	Diameter of a tailstock (1) (diameter input)
L2	Length of a tailstock (2)
D2	Diameter of a tailstock (2) (diameter input)
D3	Diameter of the hole of a tailstock (diameter input)

TZ: Specifies the position (point B) of a tailstock with the Z-axis coordinate of the workpiece coordinate system. In this case, do not use the coordinate of the machine coordinate system. The profile of a tailstock is assumed to be symmetrical with respect to the Z-axis.

WARNING

Specifying the position of a tailstock with a radius or diameter depends on whether the Z-axis conforms to radius or diameter specification.

L, L1, L2, D, D1, D2, and D3:

Define the profile of a tailstock.

WARNING

D, D1, D2, and D3 are always specified with diameters. L, L1, and L2 are also specified with radii whenever the Z-axis conforms to radius specification.

Alarm and message

Number	Message	Description
502	OVER TRAVEL : +X	The tool has entered the forbidden area when moving in the positive direction along the X-axis.
	OVER TRAVEL : +Z	The tool has entered the forbidden area when moving in the positive direction along the Z-axis.
503	OVER TRAVEL : -X	The tool has entered the forbidden area when moving in the negative direction along the X-axis.
	OVER TRAVEL : -Z	The tool has entered the forbidden area when moving in the negative direction along the Z-axis.

Warning**WARNING**

- 1 Invalid settings will result in the absence of a prohibited area, as follows:
 - 1) In the setting of the chuck shape, if the jaw length (parameter No. 1331) is less than the grasp length (parameter No. 1333) or if the jaw width (parameter No. 1332) is less than the grasp width (parameter No. 1334).
 - 2) In the setting of the tailstock shape, if the tailstock diameter (parameter No. 1346) is less than the hole diameter (parameter No. 1347).
 - 3) If the position of a chuck overlaps the position of a tailstock.
- 2 When the options for stored stroke check 2 and chuck/tailstock barrier are used at the same time, the chuck/tailstock barrier is valid but stored stroke check 2 is ignored.

Reference item

Series 16i/18i/160i/180i/ 160is/180is	OPERATOR'S MANUAL (For Lathe) (B-63524EN)	III.6.4	Chuck and Tailstock Barriers
Series 21i/210i/210is	OPERATOR'S MANUAL (For Lathe) (B-63604EN)	III.6.4	Chuck and Tailstock Barriers

2.3.5 Tool Post Interference Check (T series (Two-path Control))

General

When two tool posts machine the same workpiece simultaneously, the tool posts can approach each other very closely. If the two tool posts interfere with each other due to a program error or any other setting error, serious damage such as a tool or machine destruction can occur. The function “tool post interference check” is available to decelerate and stop the two tool posts before they interfere with each other.

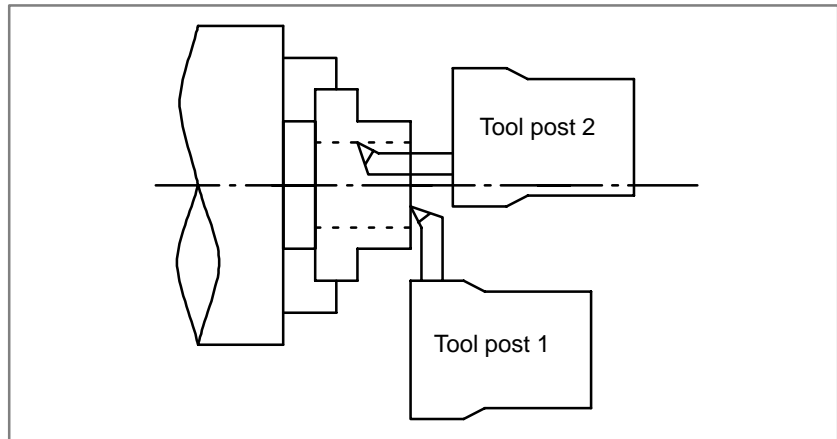

The contours of the two tool posts are checked to determine whether an interference occurs or not.

Signal

Tool post interference check signal TICLK <F064#6>

[Classification] Output signal

[Function] Indicating whether the tool post interference check function is being performed.

[Output condition] This signal goes to “1” when:

- (i) All conditions for the tool post interference check function are satisfied.

This signal goes to “0” when:

- (i) The conditions for the tool post interference check function are not completely satisfied.

The detailed conditions for the tool post interference check function, please refer to the operator’s manual for Lathe.

**Tool post interference
alarm signal
TIALM <F064#7>**

[Classification] Output signal

[Function] Indicates that the tool post interference alarm is activated.

[Output condition] This signal goes “1” when:

- (i) The control unit judges that the two tool posts will interfere with each other during the execution of the tool post interference check function.

This signal goes “0” when:

- (i) The control unit judges that the two tool posts will not interfere with each other during the execution of the tool post interference function.
- (ii) When the tool post interference check function is not being performed (i.e., the TICHK signal is “0”).

NOTE

- 1 During the execution of the interference check function, if the control unit judges that the two tool posts will interfere with each other, it stops both tool posts by slowing them down, and then enters the alarm state. The CNC then sets the TIALM signal “1” to indicate that an interference alarm has occurred.
- 2 If the interference alarm is occurred, switch the operation mode to the manual mode, manually withdraw the tool posts to where they do not interfere each other, then release the alarm status by resetting the control unit.
As the result of manually withdrawing the tool posts, the TIALM signal goes “0” when the control unit judges that the tool posts are separated enough not to interfere with each other any more. When manually withdrawing the interfering tool posts, the TIALM signal is effective in identifying how far the tool posts must be separated from each other. This is because it is easy for the operator to check at the point which the signal goes “0”.
- 3 If an interference alarm occurs, the axis being moved and its moving direction are stored, and the axis cannot be moved in the stored direction until the alarm is released by resetting the control unit. This prevents the axis from interfering any further by prohibiting movement in the direction that caused the interference.

Signal address

	#7	#6	#5	#4	#3	#2	#1	#0
F064	TIALM	TICLK						

Parameter

	#7	#6	#5	#4	#3	#2	#1	#0
8140			ZCL	IFE	IFM	ITO	TY1	TY0

[Data type] Bit

TY0, TY1 This parameter specifies the relationship between the coordinate systems of the two tool posts.

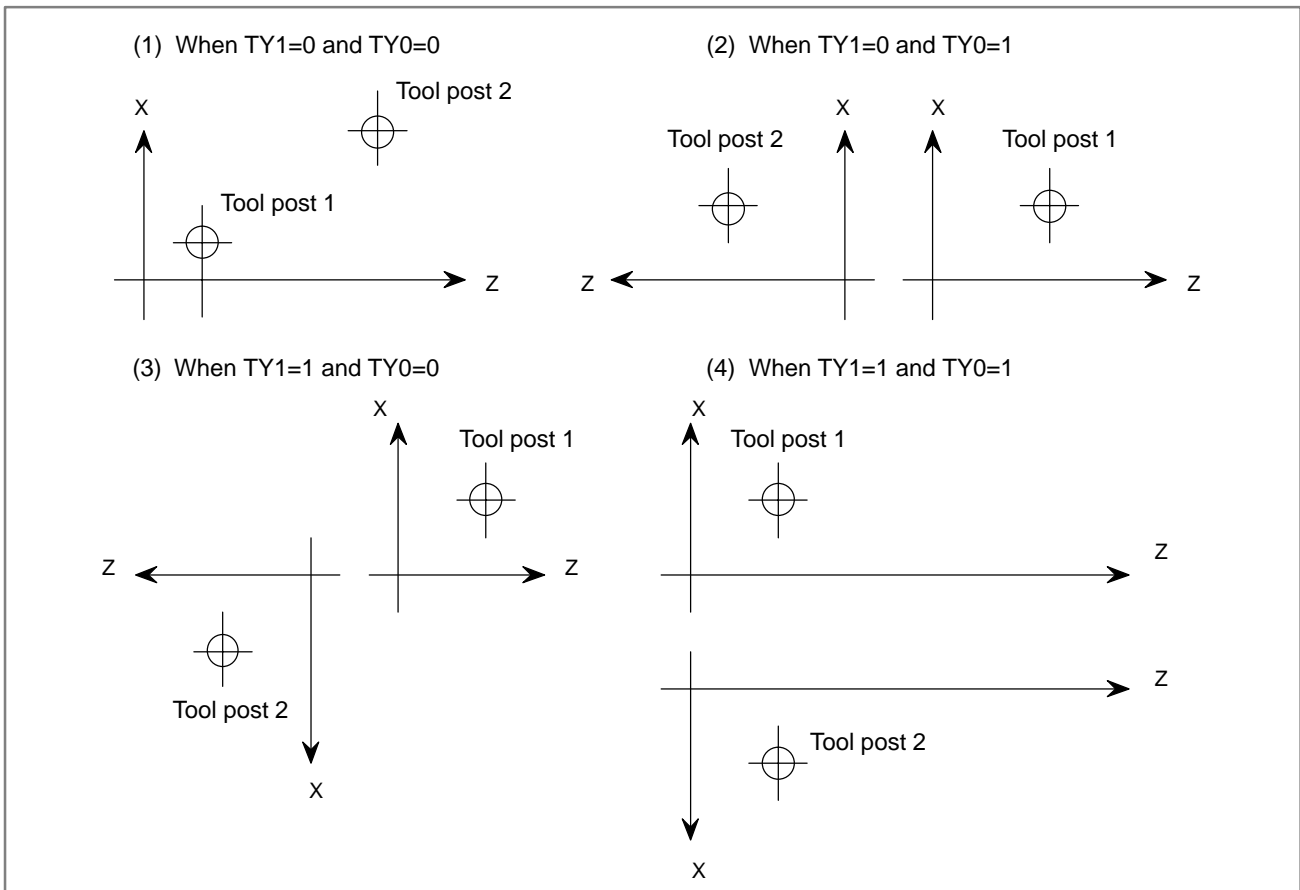

ITO When offset number 0 is specified by the T code,

- 0: Checking interference between tool posts is stopped until an offset number other than 0 is specified by the next T code.
- 1: Checking interference between tool posts is continued according to the previously specified offset number.

IFM Specifies whether interference between tool posts is checked in the manual operation mode.

- 0: Not checked
- 1: Checked

IFE Specifies whether interference between tool posts is checked.

0: Checked

1: Not checked

ZCL Specifies whether interference along the Z axis is checked while checking interference between tool posts.

0: Checked

1: Not checked (Only interference along the X axis is checked.)

8151	Distance along the X axis between the reference positions of tool posts 1 and 2
8152	Distance along the Z axis between the reference positions of tool posts 1 and 2

[Data type] Two-word

[Unit of data]	Increment system	IS-B	IS-C	Unit
	Metric input	0.001	0.0001	mm
	Inch input	0.0001	0.00001	inch

[Valid data range] -99999999 to 99999999

Indicating the distance between two tool posts.

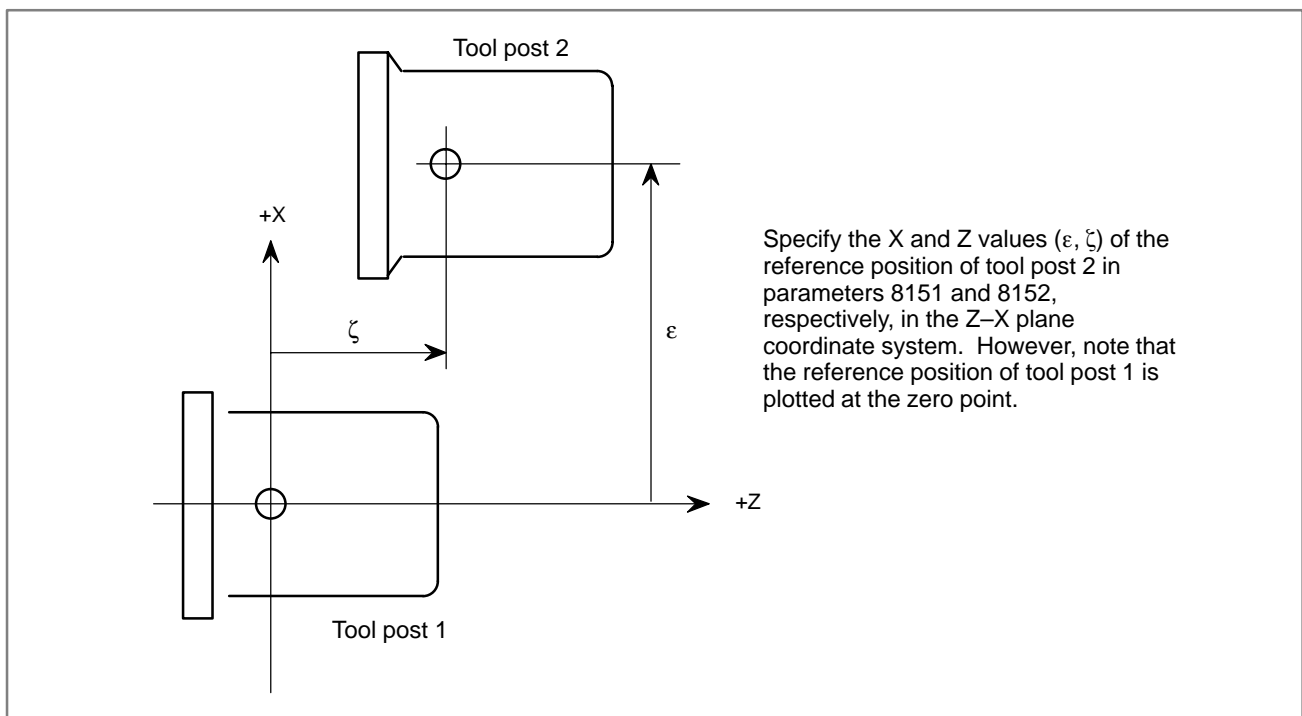

WARNING

After the parameter values are changed, it is essential to perform manual reference position return for the individual tool posts. Otherwise, data on the positional relationship between the tool posts stored in memory will not be updated to the new parameter values.

Alarm and message

Number	Message	Description
169	ILLEGAL TOOL GEOMETRY DATA	Invalid tool figure data in interference check.
508	INTERFERENCE : +X INTERFERENCE : +Z	An interference alarm has been generated when X or Z axis is moving in the positive direction.
509	INTERFERENCE : -X INTERFERENCE : -Z	An interference alarm has been generated when X or Z axis is moving in the negative direction.

Warning

WARNING

- When an alarm is raised, the CNC system and machine system stop after some time delay. So the actual tool position at stop will be closer than calculated using just tool geometry data. So, for safety, tool shape data should be set a little larger than the actual shape. The extra distance, L, required for this purpose is calculated from a rapid traverse feedrate as follows

$$L = (\text{Rapid traverse rate}) \times \frac{1}{7500}$$

For example, when a rapid traverse feedrate of 15 m/min is used, L=2mm.

- When parameters or tool shape data (contact forbidden area) are set for the interference check, verify that the interference forbidden area is correctly set. To do this, operate in manual mode and move the tool posts in all possible directions so that interference is checked from all directions. Interference check must be enabled.

Note

NOTE

- Tool number
Tool shape data must be set for each tool number. The tool number used here represents the offset number. When both the geometry offset and the wear offset are used, the offset number corresponds to the wear offset number. When multiple offset numbers are used for one tool, the same tool shape data must be set.
- Number of tool offset
The maximum number of tool numbers for which this function can indicate and set tool shape data (contact forbidden area) is 64.

Reference item

Series 16i/18i/160i/180i/ 160is/180is	OPERATOR'S MANUAL (For Lathe) (B-63524EN)	II.20.3	Tool post interference check
---	--	---------	------------------------------

**2.3.6
Stroke Limit Check
Before Move**

General

In automatic operation, before executing the move command by a given block, the position of the end point is determined. It is calculated from the current position of the machine and from the specified amount of travel. It is also determined whether or not the tool will enter the prohibited area defined by stored stroke check 1, 2 or 3. If it is determined that the tool will enter the prohibited area defined by a stored stroke check, the tool is stopped immediately once this block starts execution, and an alarm is displayed.

WARNING

Only the coordinates of the end point, reached as a result of traversing the distance specified in each block, are checked against the prohibited area. The coordinates along the path are not checked. However, if the tool enters the prohibited area defined by stored stroke check 1, 2, or 3, an alarm is issued at that point along the path. (See the examples below.)

Example 1)

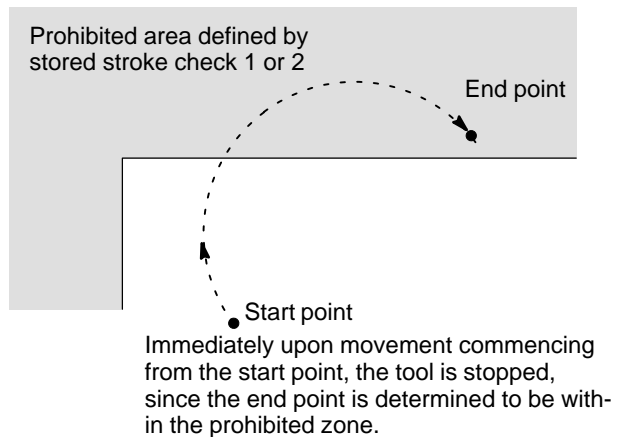
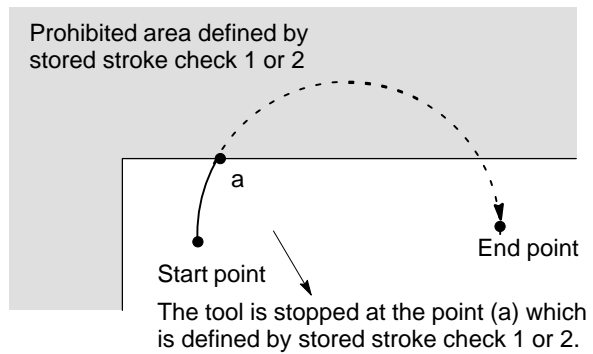

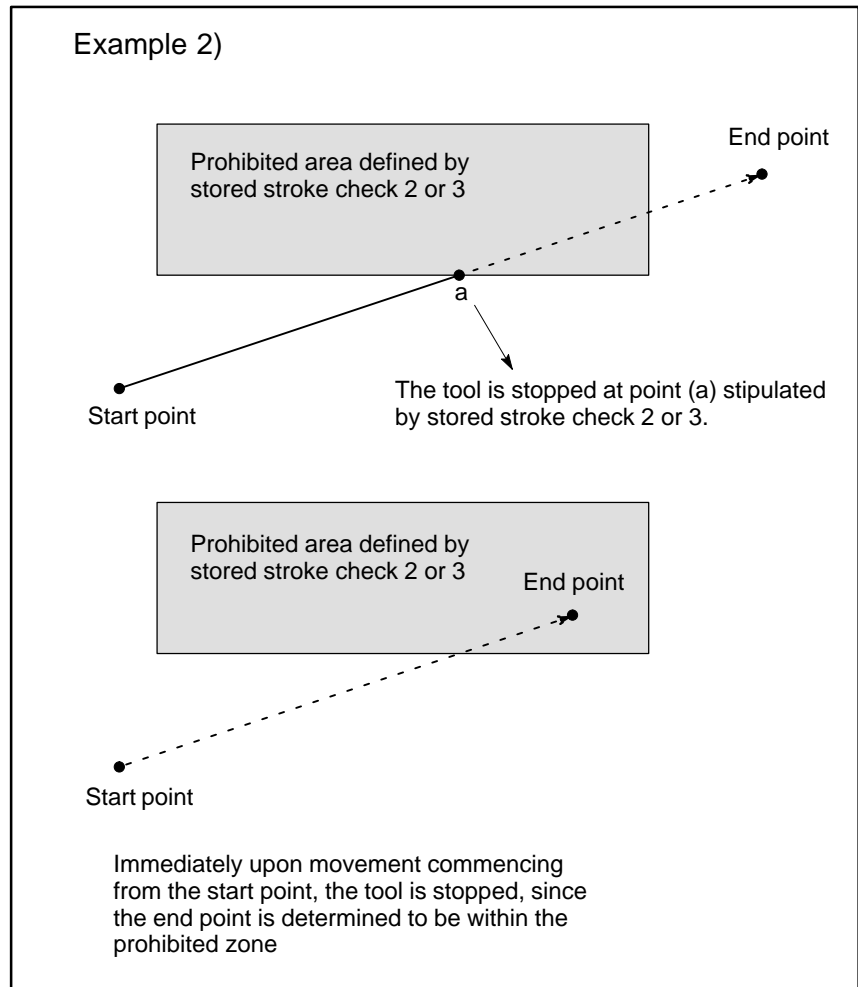

Explanations

When a stroke limit check before move is performed, NPC (parameter No. 1301#2) is used to determine whether to check the moves performed by G31 (skip) or G37 (automatic tool length measurement).

Limitations

- **Machine lock**

If machine lock is applied at the start of movement, no stroke limit check made before movement is performed.
- **G23**

When stored stroke check 2 is disabled (G23 mode), no check is made to determine whether the tool enters the prohibited area defined by stored stroke check 2.
- **Program restart**

When a program is restarted, an alarm is issued if the restart position is within a prohibited area.
- **Manual intervention following a feed hold stop**

When the execution of a block is restarted after manual intervention following a feed hold stop, no alarm is issued even though the end point following a manual intervention is within a prohibited area.
- **A block consisting of multiple operations**

If a block consisting of multiple operations (such as a canned cycle and exponential interpolation (M series only) is executed, an alarm is issued at the start point of any operation whose end point falls within a prohibited area.

- **Cylindrical interpolation mode** In cylindrical interpolation mode, no check is made.
- **Polar coordinate interpolation mode** In polar coordinate interpolation mode, no check is made.
- **Angular axis control** When the angular axis control option is selected, no check is made.
- **Simple synchronous control** In simple synchronous control, only the master axis is checked; no slave axes are checked.
- **Three-dimensional coordinate conversion** In three-dimensional coordinate conversion mode, no check is made. (M series only)
- **Drawing** While drawing in dynamic graphic display mode (only drawing is performed), no check is made. (M series)
- **PMC axis control** No check is made for a movement based on PMC axis control.
- **High-speed high-precision contour control (HPCC)** No check is made for a movement based on high-speed, high-precision contour control (HPCC). (M series only)
- **Chuck/tailstock barrier** The chuck/tailstock barrier area is not checked. (T series)
- **Synchronous control and composite control** Axes subject to synchronous control and composite control are not checked. (T series)

Parameter

	#7	#6	#5	#4	#3	#2	#1	#0
1301	PLC					NPC		

[Data type] Bit

NPC As part of the stroke limit check performed before movement, the movement specified in G31 (skip) and G37 (automatic tool length measurement (for M series) or automatic tool compensation (for T series)) blocks is:

- 0: Checked
- 1: Not checked

PLC Stroke limit check before movement is:

- 0: Not performed
- 1: Performed

Alarm and message

Number	Message	Contents
510	OVER TRAVEL : +n	The stroke limit check made prior to performing movement reveals that the end point of a block is located within the stroke limit prohibited area in the positive direction of the n-axis. Correct the program or redefine the prohibited area.
511	OVER TRAVEL : -n	The stroke limit check made prior to performing movement reveals that the end point of a block is located within the stroke limit prohibited area in the negative direction of the n-axis. Correct the program or redefine the prohibited area.

Reference item

Series 16i/18i/160i/180i/ 160is/180is	OPERATOR'S MANUAL (For Machining Center) (B-63534EN)	III.6.4	Stroke Limit Check Prior to Performing Movement
	OPERATOR'S MANUAL (For Lathe) (B-63524EN)	III.6.5	Stroke Limit Check Prior to Performing Movement

2.3.7 Rotation Area Interference Check

General

This function checks for interference among the tool post and chucks and stops the machine safely. Three major interference check areas can be set, each of which is specified by using rectangles. Two of the three interference check areas can be moved and rotated.

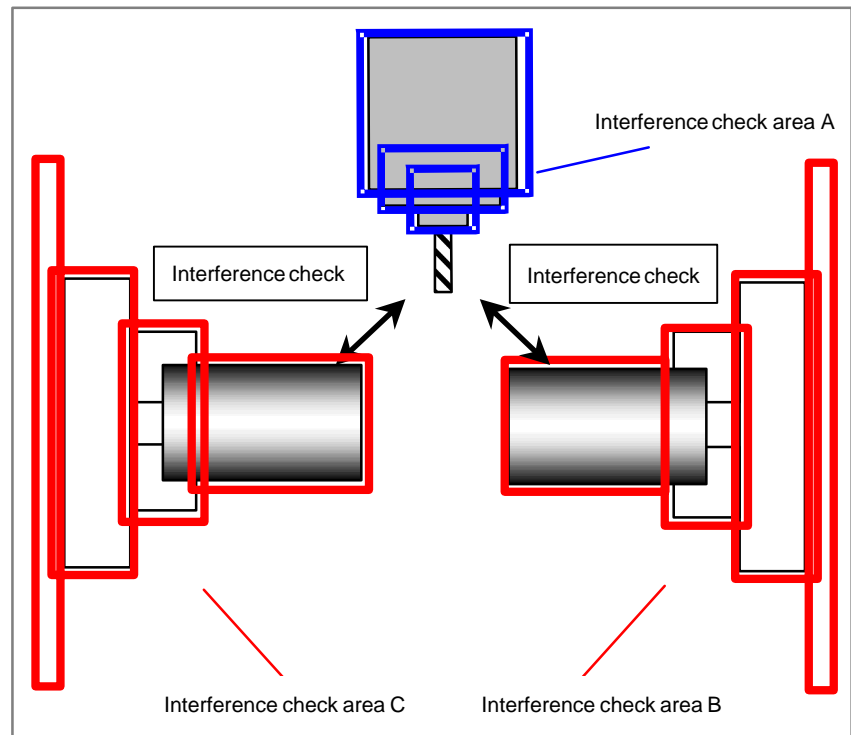

You can set the following interference check areas:

- 1) Interference check area A and interference check area B
You can set four rectangles. The entire area moves according to the movement along parameter-set two axes. In addition, the entire area can be rotated according to the rotation on a parameter-set axis.
- 2) Interference check area C
You can set four rectangles. The area cannot be moved and rotated.

Operation

• **Areas A and B**

There are three possible interference check patterns as follows.

A check is made to see whether an interference between areas A and B occurs as a result of the movement and rotation of area A and the movement and rotation of area B.

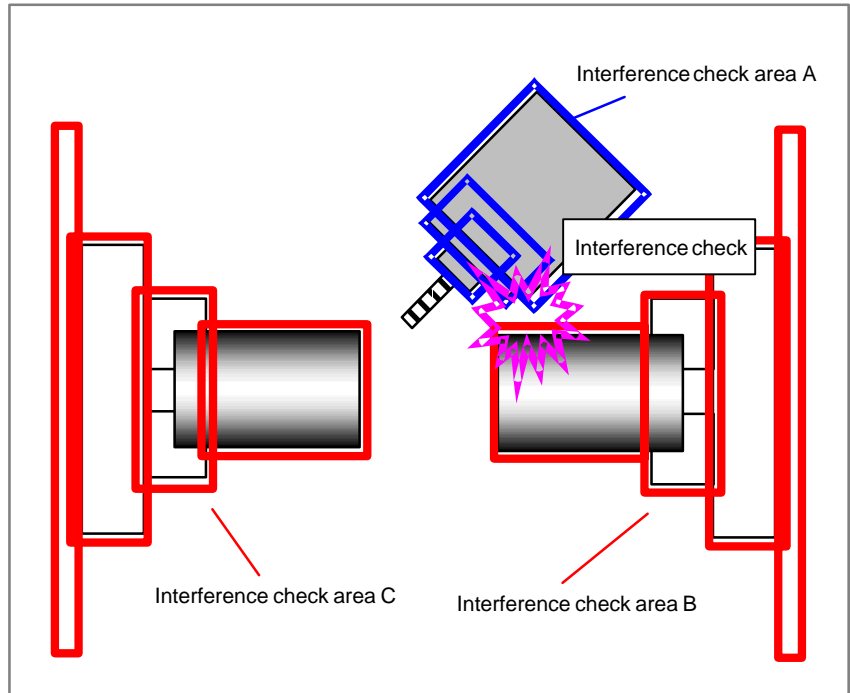

• **Areas A and C**

A check is made to see whether the movement and rotation of area A interferes with area C.

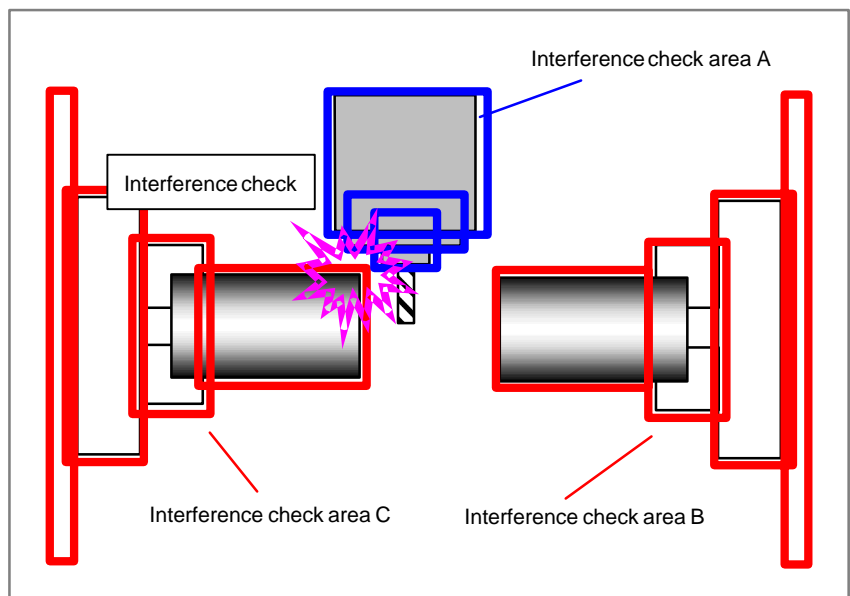

- **Areas B and C**

A check is made to see whether the movement and rotation of area B interferes with area C.

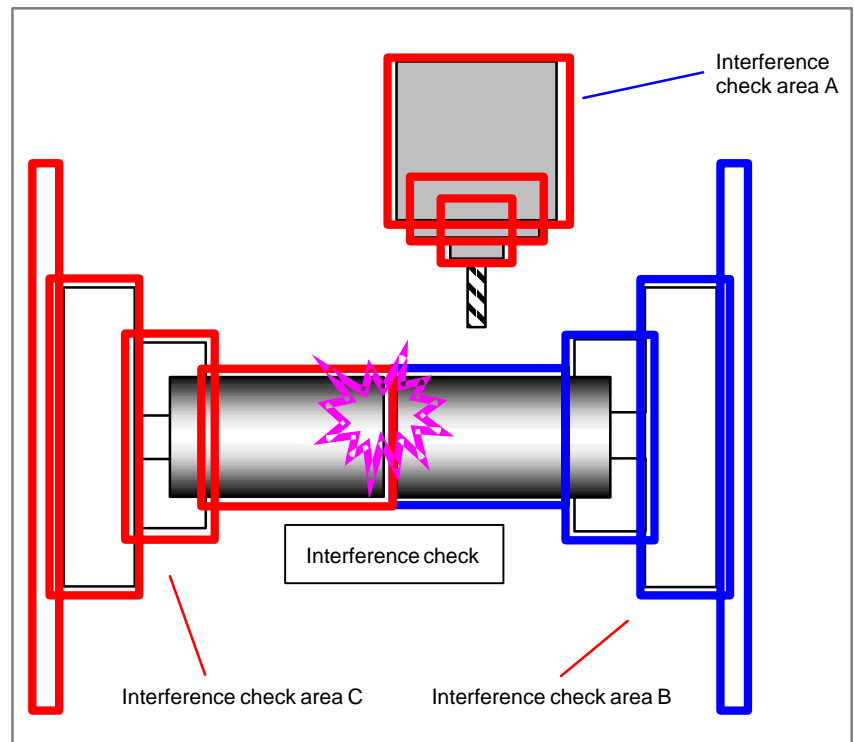

Each interference check is performed as required. It takes 24 msec to complete processing for checking all areas. (This processing time can be changed by setting bits 4 to 7 of parameter No. 14900.)

NOTE

- 1 Each interference check is performed as required. It takes 24 msec to complete processing for checking all areas. (This processing time may be changed by setting bits 4 to 7 of parameter No. 14900.)
- 2 If the interference check detects an interference, alarm "514 Interfering: +n Axis" or "515 Interfering: -n Axis" is issued. The alarm is issued for all axes relating to the area in which the interference occurred. If an alarm is issued, all CNC-controlled axes are stopped during automatic operation; during manual operation, only the axes belonging to the area in which the interference occurred are stopped.

● **Example**

Axes along which interference check area A is displaced in parallel:
X-axis, Z-axis

Rotation axis: B-axis

When a movement along the X-axis in the negative direction causes an interference with interference area C

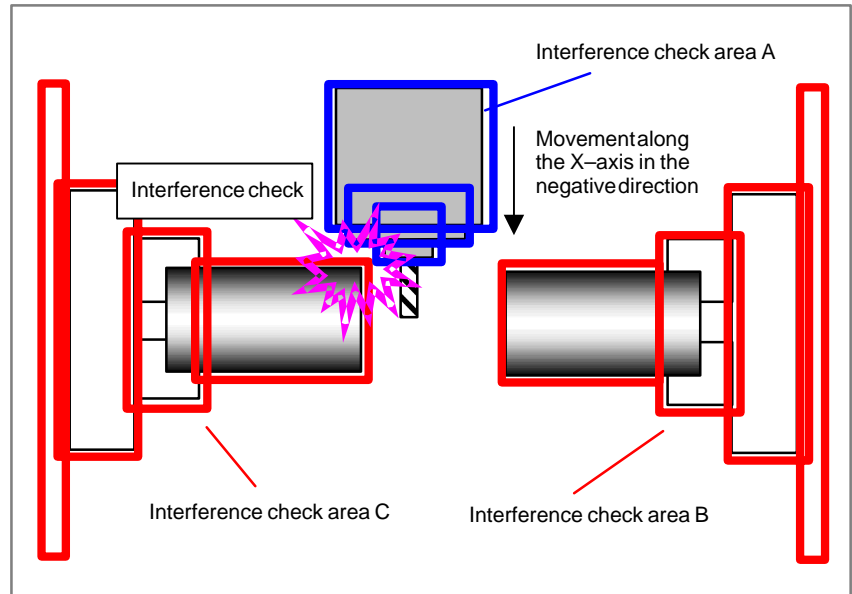

The alarm of the negative direction of the X-axis and alarms of related axes are issued.

ACTUAL POSITION		00000 N00000	
<RELATIVE>		<ABSOLUTE>	
U	-399.786	X	-400.000
W	-200.027	Z	-200.133
H	906.299	C	0.000
V	-0.097	Y	0.000
B	0.106	B	0.000
<MACHINE>			
X	-400.000		
Z	-200.133		
C	0.000		
Y	0.000		
B	0.000		
<MODAL>			
G01	G25	G18	F M
G97	G22	G69.1	S M
G69	G80	G13.1	SRPM 0 M
G99	G67		SSPM 0
G21	G54		SMAX 32767
G40	G64		SACT 0
HD. T		NX. T	

F	0	MM/M
JOG F	500	PART COUNT 0
RUN TIME	0H49M	CYCLE TIME 0H 0M 0S

ALARM MESSAGE	
514	INTERFERENCE :+B
515	INTERFERENCE :-X
515	INTERFERENCE :-Z
515	INTERFERENCE :-B

S 0 L 0%

JOG ***** ALM 14:08:51

ABS	REL	ALL +			ALARM	MSG	HISTRY		
-----	-----	-------	--	--	-------	-----	--------	--	--

NOTE

1 Alarms cannot be issued before an interference check area is exceeded. Therefore, you need to define areas with enough allowance according to the feedrate. The distance of movement along an axis until an interference is determined (the distance of movement after the interference area is entered) is obtained from the following formula:

$$D = F \div 60 \times (\text{interference check processing time})$$

D: The distance of movement after the area is entered
[0.001 mm (IS-B)]

F: Maximum rapid traverse rate [mm/min]

2 After an alarm is issued, movement can be made along each axis in the opposite direction to the interfering direction. Ensure safety, then move the machine in the direction opposite to the interfering direction.

3 When the reference position has not been established, the interference check is not made.

4 You can disable the interference check by using rotation area interference check disable signal (ITCD<G0292#7>).

Signal

**Rotation area
interference check
disable signal
ITCD <G292#7>**

[Classification] Input signal

[Function] Enables or disables the rotation area interference check function.

ITCD 1 : Disables the interference check function.

0 : Enables the interference check function.

Signal address

	#7	#6	#5	#4	#3	#2	#1	#0
G292	ITCD							

Parameter

	#7	#6	#5	#4	#3	#2	#1	#0
14900	IC4	IC3	IC2	IC1	IRB	IRA	IB2	IB1

[Data type] Bit**IB1** Movement direction of group B (the first axis)

0 : The direction of movement along the first axis of the group-B movement plane is the same as the direction of movement along the first axis on the group-A movement plane.

1 : The direction of movement along the first axis of the group-B movement plane is opposite to the direction of movement along the first axis on the group-A movement plane.

IB2 Movement direction of group B (the second axis)

0 : The direction of movement along the second axis of the group-B movement plane is the same as the direction of movement along the second axis on the group-A movement plane.

1 : The direction of movement along the second axis of the group-B movement plane is opposite to the direction of movement along the second axis of the group-A movement plane.

IRA Rotation direction of the rotation axis on which group A is rotated

0 : The direction of a rotation from the positive side of the first axis of the plane to the positive side of the second axis is assumed to be the positive direction of the rotation axis on which group A is rotated.

1 : The direction of a rotation from the positive side of the first axis of the plane to the positive side of the second axis is assumed to be the negative direction of the rotation axis on which group A is rotated.

IRB Rotation direction of the rotation axis on which group B is rotated

0 : The direction of a rotation from the positive side of the first axis of the plane to the positive side of the second axis is assumed to be the positive direction of the rotation axis on which group B is rotated.

1 : The direction of a rotation from the positive side of the first axis of the plane to the positive side of the second axis is assumed to be the negative direction of the rotation axis on which group B is rotated.

IC1 to IC4 Processing time required to make the interference check

The time it takes to process all interference checks is obtained from the following formula:

$$T [\text{msec}] = ((\text{the number of the rectangles of group A}) \times (\text{the number of the rectangles of group B}) + (\text{the number of the rectangles of group A}) \times (\text{the number of the rectangles of group C}) + (\text{the number of the rectangles of group B}) \times (\text{the number of the rectangles of group C})) \div (\text{setting in IC1 to IC4}) \times 8$$

The processing time is a multiple of 8. If the calculated value of the processing time is smaller than 8, the processing time is assumed to be 8 msec.

Setting	IC4	IC3	IC2	IC1
16	0	0	0	0
4	0	0	0	1
8	0	0	1	0
12	0	0	1	1
16	0	1	0	0
20	0	1	0	1
24	0	1	1	0
28	0	1	1	1
32	1	0	0	0
36	1	0	0	1
40	1	0	1	0
44	1	0	1	1
48	1	1	0	0
52(48)	1	1	0	1
56(48)	1	1	1	0
60(48)	1	1	1	1

14910

Axis number of the first axis of the plane on which group A is moved

[Data type] Byte

[Unit of data]

[Valid data range] 0 to the number of controlled axes

This parameter sets the axis number of the first axis of the group-A movement plane.

Set the first axis of the basic plane.

If there is no relevant movement axis, set 0.

Example: When an interference check is made on the Z-X plane, the first axis is the Z-axis.

14911

Axis number of the second axis of the plane on which group A is moved

[Data type] Byte**[Unit of data]****[Valid data range]** 0 to the number of controlled axes

This parameter sets the axis number of the second axis of the group–A movement plane.

Set the second axis of the basic plane.

If there is no relevant movement axis, set 0.

Example: When an interference check is made on the Z–X plane, the second axis is the X–axis.

14912

Axis number of the rotation axis on which group A is rotated

[Data type] Byte**[Unit of data]****[Valid data range]** 0 to the number of controlled axes

This parameter sets the axis number of a rotation axis used for rotating group A.

If there is no relevant rotation axis, set 0.

14913

Axis number of the first axis of the plane on which group B is moved

[Data type] Byte**[Unit of data]****[Valid data range]** 0 to the number of controlled axes

This parameter sets the axis number of the first axis of the group–B movement plane.

Set an axis parallel to the first axis of the group–A movement plane.

If there is no relevant movement axis, set 0.

14914

Axis number of the second axis of the plane on which group B is moved

[Data type] Byte**[Unit of data]****[Valid data range]** 0 to the number of controlled axes

This parameter sets the axis number of the second axis of the group–B movement plane.

Set an axis parallel to the second axis of the group–A movement plane.

If there is no relevant movement axis, set 0.

14915	Axis number of the rotation axis on which group B is rotated
-------	--

[Data type] Byte

[Unit of data]

[Valid data range] 0 to the number of controlled axes

This parameter sets the axis number of a rotation axis used for rotating group B.

If there is no relevant rotation axis, set 0.

14920	Maximum point of rectangle 1 of group A in the first axis
-------	---

14921	Minimum point of rectangle 1 of group A in the first axis
-------	---

[Data type] Two-word

[Unit of data]	Increment system	IS-B	IS-C	Unit
	Millimeter machine	0.001	0.0001	mm
	Inch machine	0.0001	0.00001	inch

[Valid data range] -99999999 to 99999999

These parameters set the maximum point and minimum point of rectangle area 1 of group A in the first axis.

When a rotation axis is present (parameter No. 14912), set the distances from the machine zero point to the maximum and minimum points after the reference position return has been performed for the group-A movement axes with the rotation axis set at the reference angular displacement (parameter No. 14938).

Be sure to set a radius value regardless of whether the axis command is a diameter- or radius-programmed command.

The set plane is specified with group-A movement axes 1 and 2.

If there is no relevant rectangle area, set 0.

14922	Maximum point of rectangle 1 of group A in the second axis
-------	--

14923	Minimum point of rectangle 1 of group A in the second axis
-------	--

[Data type] Two-word

[Unit of data]	Increment system	IS-B	IS-C	Unit
	Millimeter machine	0.001	0.0001	mm
	Inch machine	0.0001	0.00001	inch

[Valid data range] -99999999 to 99999999

These parameters set the maximum point and minimum point of rectangle area 1 of group A in the second axis.

When a rotation axis is present (parameter No. 14912), set the distances from the machine zero point to the maximum and minimum points after the reference position return has been performed for the group-A movement axes with the rotation axis set at the reference angular displacement (parameter No. 14938).

Be sure to set a radius value regardless of whether the axis command is a diameter- or radius-programmed command.

The set plane is specified with group-A movement axes 1 and 2.

If there is no relevant rectangle area, set 0.

14924	Maximum point of rectangle 2 of group A in the first axis
-------	---

14925	Minimum point of rectangle 2 of group A in the first axis
-------	---

[Data type] Two-word

[Unit of data]	Increment system	IS-B	IS-C	Unit
	Millimeter machine	0.001	0.0001	mm
	Inch machine	0.0001	0.00001	inch

[Valid data range] -99999999 to 99999999

These parameters set the maximum point and minimum point of rectangle area 2 of group A in the first axis.

When a rotation axis is present (parameter No. 14912), set the distances from the machine zero point to the maximum and minimum points after the reference position return has been performed for the group-A movement axes with the rotation axis set at the reference angular displacement (parameter No. 14938).

Be sure to set a radius value regardless of whether the axis command is a diameter- or radius-programmed command.

The set plane is specified with group-A movement axes 1 and 2.

If there is no relevant rectangle area, set 0.

14926	Maximum point of rectangle 2 of group A in the second axis
-------	--

14927	Minimum point of rectangle 2 of group A in the second axis
-------	--

[Data type] Two-word

[Unit of data]	Increment system	IS-B	IS-C	Unit
	Millimeter machine	0.001	0.0001	mm
	Inch machine	0.0001	0.00001	inch

[Valid data range] -99999999 to 99999999

These parameters set the maximum point and minimum point of rectangle area 2 of group A in the second axis.

When a rotation axis is present (parameter No. 14912), set the distances from the machine zero point to the maximum and minimum points after the reference position return has been performed for the group-A movement axes with the rotation axis set at the reference angular displacement (parameter No. 14938).

Be sure to set a radius value regardless of whether the axis command is a diameter- or radius-programmed command.

The set plane is specified with group-A movement axes 1 and 2.

If there is no relevant rectangle area, set 0.

14928	Maximum point of rectangle 3 of group A in the first axis
-------	---

14929	Minimum point of rectangle 3 of group A in the first axis
-------	---

[Data type] Two-word

[Unit of data]	Increment system	IS-B	IS-C	Unit
	Millimeter machine	0.001	0.0001	mm
	Inch machine	0.0001	0.00001	inch

[Valid data range] -99999999 to 99999999

These parameters set the maximum point and minimum point of rectangle area 3 of group A in the first axis.

When a rotation axis is present (parameter No. 14912), set the distances from the machine zero point to the maximum and minimum points after the reference position return has been performed for the group-A movement axes with the rotation axis set at the reference angular displacement (parameter No. 14938).

Be sure to set a radius value regardless of whether the axis command is a diameter- or radius-programmed command.

The set plane is specified with group-A movement axes 1 and 2.

If there is no relevant rectangle area, set 0.

14930	Maximum point of rectangle 3 of group A in the second axis
-------	--

14931	Minimum point of rectangle 3 of group A in the second axis
-------	--

[Data type] Two-word

[Unit of data]	Increment system	IS-B	IS-C	Unit
	Millimeter machine	0.001	0.0001	mm
	Inch machine	0.0001	0.00001	inch

[Valid data range] -99999999 to 99999999

These parameters set the maximum point and minimum point of rectangle area 3 of group A in the second axis.

When a rotation axis is present (parameter No. 14912), set the distances from the machine zero point to the maximum and minimum points after the reference position return has been performed for the group-A movement axes with the rotation axis set at the reference angular displacement (parameter No. 14938).

Be sure to set a radius value regardless of whether the axis command is a diameter- or radius-programmed command.

The set plane is specified with group-A movement axes 1 and 2.

If there is no relevant rectangle area, set 0.

14932	Maximum point of rectangle 4 of group A in the first axis
-------	---

14933	Minimum point of rectangle 4 of group A in the first axis
-------	---

[Data type] Two-word

[Unit of data]	Increment system	IS-B	IS-C	Unit
	Millimeter machine	0.001	0.0001	mm
	Inch machine	0.0001	0.00001	inch

[Valid data range] -99999999 to 99999999

These parameters set the maximum point and minimum point of rectangle area 4 of group A in the first axis.

When a rotation axis is present (parameter No. 14912), set the distances from the machine zero point to the maximum and minimum points after the reference position return has been performed for the group-A movement axes with the rotation axis set at the reference angular displacement (parameter No. 14938).

Be sure to set a radius value regardless of whether the axis command is a diameter- or radius-programmed command.

The set plane is specified with group-A movement axes 1 and 2.

If there is no relevant rectangle area, set 0.

14934	Maximum point of rectangle 4 of group A in the second axis
-------	--

14935	Minimum point of rectangle 4 of group A in the second axis
-------	--

[Data type] Two-word

[Unit of data]	Increment system	IS-B	IS-C	Unit
	Millimeter machine	0.001	0.0001	mm
	Inch machine	0.0001	0.00001	inch

[Valid data range] -99999999 to 99999999

These parameters set the maximum point and minimum point of rectangle area 4 of group A in the second axis.

When a rotation axis is present (parameter No. 14912), set the distances from the machine zero point to the maximum and minimum points after the reference position return has been performed for the group-A movement axes with the rotation axis set at the reference angular displacement (parameter No. 14938).

Be sure to set a radius value regardless of whether the axis command is a diameter- or radius-programmed command.

The set plane is specified with group-A movement axes 1 and 2.

If there is no relevant rectangle area, set 0.

14936	Rotation center in the first axis when group A is rotated
-------	---

14937	Rotation center in the second axis when group A is rotated
-------	--

[Data type] Two-word

[Unit of data]	Increment system	IS-B	IS-C	Unit
	Millimeter machine	0.001	0.0001	mm
	Inch machine	0.0001	0.00001	inch

[Valid data range] -99999999 to 99999999

These parameters set the rotation center when group A is rotated.

Set the distances from the machine zero point after reference position return has been performed for group-A movement axes.

Be sure to set a radius value regardless of whether the axis command is a diameter- or radius-programmed command.

The set plane is specified with group-A movement axes 1 and 2.

If there is no relevant rectangle area, set 0.

14938	Reference angular displacement of the rotation axis of group A
-------	--

[Data type] Two-word

[Unit of data]	Increment system	IS-B	IS-C	Unit
	Millimeter machine	0.001	0.0001	mm
	Inch machine	0.0001	0.00001	inch

[Valid data range] -99999999 to 99999999

This parameter sets the coordinate value (reference angular displacement) of the rotation axis when rectangle areas of group A are set for the interference check function.

If there is no relevant rotation axis, set 0.

14940	Maximum point of rectangle 1 of group B in the first axis
-------	---

14941	Minimum point of rectangle 1 of group B in the first axis
-------	---

[Data type] Two-word

[Unit of data]	Increment system	IS-B	IS-C	Unit
	Millimeter machine	0.001	0.0001	mm
	Inch machine	0.0001	0.00001	inch

[Valid data range] -99999999 to 99999999

These parameters set the maximum point and minimum point of rectangle area 1 of group B in the first axis.

When a rotation axis is present (parameter No. 14915), set the distances from the machine zero point to the maximum and minimum points after the reference position return has been performed for the group-B movement axes with the rotation axis set at the reference angular displacement (parameter No. 14958).

Be sure to set a radius value regardless of whether the axis command is a diameter- or radius-programmed command.

The set plane is specified with group-A movement axes 1 and 2.

If there is no relevant rectangle area, set 0.

14942	Maximum point of rectangle 1 of group B in the second axis
-------	--

14943	Minimum point of rectangle 1 of group B in the second axis
-------	--

[Data type] Two-word

[Unit of data]	Increment system	IS-B	IS-C	Unit
	Millimeter machine	0.001	0.0001	mm
	Inch machine	0.0001	0.00001	inch

[Valid data range] -99999999 to 99999999

These parameters set the maximum point and minimum point of rectangle area 1 of group B in the second axis.

When a rotation axis is present (parameter No. 14915), set the distances from the machine zero point to the maximum and minimum points after the reference position return has been performed for the group-B movement axes with the rotation axis set at the reference angular displacement (parameter No. 14958).

Be sure to set a radius value regardless of whether the axis command is a diameter- or radius-programmed command.

The set plane is specified with group-A movement axes 1 and 2.

If there is no relevant rectangle area, set 0.

14944	Maximum point of rectangle 2 of group B in the first axis
-------	---

14945	Minimum point of rectangle 2 of group B in the first axis
-------	---

[Data type] Two-word

[Unit of data]	Increment system	IS-B	IS-C	Unit
	Millimeter machine	0.001	0.0001	mm
	Inch machine	0.0001	0.00001	inch

[Valid data range] -99999999 to 99999999

These parameters set the maximum point and minimum point of rectangle area 2 of group B in the first axis.

When a rotation axis is present (parameter No. 14915), set the distances from the machine zero point to the maximum and minimum points after the reference position return has been performed for the group-B movement axes with the rotation axis set at the reference angular displacement (parameter No. 14958).

Be sure to set a radius value regardless of whether the axis command is a diameter- or radius-programmed command.

The set plane is specified with group-A movement axes 1 and 2.

If there is no relevant rectangle area, set 0.

14946	Maximum point of rectangle 2 of group B in the second axis
-------	--

14947	Minimum point of rectangle 2 of group B in the second axis
-------	--

[Data type] Two-word

[Unit of data]	Increment system	IS-B	IS-C	Unit
	Millimeter machine	0.001	0.0001	mm
	Inch machine	0.0001	0.00001	inch

[Valid data range] -99999999 to 99999999

These parameters set the maximum point and minimum point of rectangle area 2 of group B in the second axis.

When a rotation axis is present (parameter No. 14915), set the distances from the machine zero point to the maximum and minimum points after the reference position return has been performed for the group-B movement axes with the rotation axis set at the reference angular displacement (parameter No. 14958).

Be sure to set a radius value regardless of whether the axis command is a diameter- or radius-programmed command.

The set plane is specified with group-A movement axes 1 and 2.

If there is no relevant rectangle area, set 0.

14948	Maximum point of rectangle 3 of group B in the first axis
-------	---

14949	Minimum point of rectangle 3 of group B in the first axis
-------	---

[Data type] Two-word

[Unit of data]	Increment system	IS-B	IS-C	Unit
	Millimeter machine	0.001	0.0001	mm
	Inch machine	0.0001	0.00001	inch

[Valid data range] -99999999 to 99999999

These parameters set the maximum point and minimum point of rectangle area 3 of group B in the first axis.

When a rotation axis is present (parameter No. 14915), set the distances from the machine zero point to the maximum and minimum points after the reference position return has been performed for the group-B movement axes with the rotation axis set at the reference angular displacement (parameter No. 14958).

Be sure to set a radius value regardless of whether the axis command is a diameter- or radius-programmed command.

The set plane is specified with group-A movement axes 1 and 2.

If there is no relevant rectangle area, set 0.

14950	Maximum point of rectangle 3 of group B in the second axis
-------	--

14951	Minimum point of rectangle 3 of group B in the second axis
-------	--

[Data type] Two-word

[Unit of data]	Increment system	IS-B	IS-C	Unit
	Millimeter machine	0.001	0.0001	mm
	Inch machine	0.0001	0.00001	inch

[Valid data range] -99999999 to 99999999

These parameters set the maximum point and minimum point of rectangle area 3 of group B in the second axis.

When a rotation axis is present (parameter No. 14915), set the distances from the machine zero point to the maximum and minimum points after the reference position return has been performed for the group-B movement axes with the rotation axis set at the reference angular displacement (parameter No. 14958).

Be sure to set a radius value regardless of whether the axis command is a diameter- or radius-programmed command.

The set plane is specified with group-A movement axes 1 and 2.

If there is no relevant rectangle area, set 0.

14952	Maximum point of rectangle 4 of group B in the first axis
-------	---

14953	Minimum point of rectangle 4 of group B in the first axis
-------	---

[Data type] Two-word

[Unit of data]	Increment system	IS-B	IS-C	Unit
	Millimeter machine	0.001	0.0001	mm
	Inch machine	0.0001	0.00001	inch

[Valid data range] -99999999 to 99999999

These parameters set the maximum point and minimum point of rectangle area 4 of group B in the first axis.

When a rotation axis is present (parameter No. 14915), set the distances from the machine zero point to the maximum and minimum points after the reference position return has been performed for the group-B movement axes with the rotation axis set at the reference angular displacement (parameter No. 14958).

Be sure to set a radius value regardless of whether the axis command is a diameter- or radius-programmed command.

The set plane is specified with group-A movement axes 1 and 2.

If there is no relevant rectangle area, set 0.

14954	Maximum point of rectangle 4 of group B in the second axis
-------	--

14955	Minimum point of rectangle 4 of group B in the second axis
-------	--

[Data type] Two-word

[Unit of data]	Increment system	IS-B	IS-C	Unit
	Millimeter machine	0.001	0.0001	mm
	Inch machine	0.0001	0.00001	inch

[Valid data range] -99999999 to 99999999

These parameters set the maximum point and minimum point of rectangle area 4 of group B in the second axis.

When a rotation axis is present (parameter No. 14915), set the distances from the machine zero point to the maximum and minimum points after the reference position return has been performed for the group-B movement axes with the rotation axis set at the reference angular displacement (parameter No. 14958).

Be sure to set a radius value regardless of whether the axis command is a diameter- or radius-programmed command.

The set plane is specified with group-A movement axes 1 and 2.

If there is no relevant rectangle area, set 0.

14956	Rotation center in the first axis when group B is rotated
-------	---

14957	Rotation center in the second axis when group B is rotated
-------	--

[Data type] Two-word

[Unit of data]	Increment system	IS-B	IS-C	Unit
	Millimeter machine	0.001	0.0001	mm
	Inch machine	0.0001	0.00001	inch

[Valid data range] -99999999 to 99999999

These parameters set the rotation center when group B is rotated. Set the distances from the machine zero point after reference position return has been performed for group-B movement axes. Be sure to set a radius value regardless of whether the axis command is a diameter- or radius-programmed command. The set plane is specified with group-A movement axes 1 and 2. If there is no relevant rectangle area, set 0.

14958	Reference angular displacement of the rotation axis of group B
-------	--

[Data type] Two-word

[Unit of data]	Increment system	IS-B	IS-C	Unit
	Millimeter machine	0.001	0.0001	mm
	Inch machine	0.0001	0.00001	inch

[Valid data range] -99999999 to 99999999

This parameter sets the coordinate value (reference angular displacement) of the rotation axis when rectangle areas of group B are set for the interference check function. If there is no relevant rotation axis, set 0.

14960	Maximum point of rectangle 1 of group C in the first axis
-------	---

14961	Minimum point of rectangle 1 of group C in the first axis
-------	---

[Data type] Two-word

[Unit of data]	Increment system	IS-B	IS-C	Unit
	Millimeter machine	0.001	0.0001	mm
	Inch machine	0.0001	0.00001	inch

[Valid data range] -99999999 to 99999999

These parameters set the maximum point and minimum point of rectangle area 1 of group C in the first axis. The set plane is specified with the group-A movement axes 1 and 2. Set the distances from the machine zero point to the maximum and minimum points. Be sure to set a radius value regardless of whether the axis command is a diameter- or radius-programmed command. If there is no relevant rectangle area, set 0.

14962	Maximum point of rectangle 1 of group C in the second axis
-------	--

14963	Minimum point of rectangle 1 of group C in the second axis
-------	--

[Data type] Two-word

[Unit of data]	Increment system	IS-B	IS-C	Unit
	Millimeter machine	0.001	0.0001	mm
	Inch machine	0.0001	0.00001	inch

[Valid data range] -99999999 to 99999999

These parameters set the maximum point and minimum point of rectangle area 1 of group C in the second axis.

The set plane is specified with the group-A movement axes 1 and 2. Set the distances from the machine zero point to the maximum and minimum points.

Be sure to set a radius value regardless of whether the axis command is a diameter- or radius-programmed command.

If there is no relevant rectangle area, set 0.

14964	Maximum point of rectangle 2 of group C in the first axis
-------	---

14965	Minimum point of rectangle 2 of group C in the first axis
-------	---

[Data type] Two-word

[Unit of data]	Increment system	IS-B	IS-C	Unit
	Millimeter machine	0.001	0.0001	mm
	Inch machine	0.0001	0.00001	inch

[Valid data range] -99999999 to 99999999

These parameters set the maximum point and minimum point of rectangle area 2 of group C in the first axis.

The set plane is specified with the group-A movement axes 1 and 2. Set the distances from the machine zero point to the maximum and minimum points.

Be sure to set a radius value regardless of whether the axis command is a diameter- or radius-programmed command.

If there is no relevant rectangle area, set 0.

14966	Maximum point of rectangle 2 of group C in the second axis
-------	--

14967	Minimum point of rectangle 2 of group C in the second axis
-------	--

[Data type] Two-word

[Unit of data]	Increment system	IS-B	IS-C	Unit
	Millimeter machine	0.001	0.0001	mm
	Inch machine	0.0001	0.00001	inch

[Valid data range] -99999999 to 99999999

These parameters set the maximum point and minimum point of rectangle area 2 of group C in the second axis.

The set plane is specified with the group-A movement axes 1 and 2. Set the distances from the machine zero point to the maximum and minimum points.

Be sure to set a radius value regardless of whether the axis command is a diameter- or radius-programmed command.

If there is no relevant rectangle area, set 0.

14968	Maximum point of rectangle 3 of group C in the first axis
-------	---

14969	Minimum point of rectangle 3 of group C in the first axis
-------	---

[Data type] Two-word

[Unit of data]	Increment system	IS-B	IS-C	Unit
	Millimeter machine	0.001	0.0001	mm
	Inch machine	0.0001	0.00001	inch

[Valid data range] -99999999 to 99999999

These parameters set the maximum point and minimum point of rectangle area 3 of group C in the first axis.

The set plane is specified with the group-A movement axes 1 and 2. Set the distances from the machine zero point to the maximum and minimum points.

Be sure to set a radius value regardless of whether the axis command is a diameter- or radius-programmed command.

If there is no relevant rectangle area, set 0.

14970	Maximum point of rectangle 3 of group C in the second axis
-------	--

14971	Minimum point of rectangle 3 of group C in the second axis
-------	--

[Data type] Two-word

[Unit of data]	Increment system	IS-B	IS-C	Unit
	Millimeter machine	0.001	0.0001	mm
	Inch machine	0.0001	0.00001	inch

[Valid data range] -99999999 to 99999999

These parameters set the maximum point and minimum point of rectangle area 3 of group C in the second axis.

The set plane is specified with the group-A movement axes 1 and 2. Set the distances from the machine zero point to the maximum and minimum points.

Be sure to set a radius value regardless of whether the axis command is a diameter- or radius-programmed command.

If there is no relevant rectangle area, set 0.

14972	Maximum point of rectangle 4 of group C in the first axis
-------	---

14973	Minimum point of rectangle 4 of group C in the first axis
-------	---

[Data type] Two-word

[Unit of data]	Increment system	IS-B	IS-C	Unit
	Millimeter machine	0.001	0.0001	mm
	Inch machine	0.0001	0.00001	inch

[Valid data range] -99999999 to 99999999

These parameters set the maximum point and minimum point of rectangle area 4 of group C in the first axis.

The set plane is specified with the group-A movement axes 1 and 2. Set the distances from the machine zero point to the maximum and minimum points.

Be sure to set a radius value regardless of whether the axis command is a diameter- or radius-programmed command.

If there is no relevant rectangle area, set 0.

14974	Maximum point of rectangle 4 of group C in the second axis
14975	Minimum point of rectangle 4 of group C in the second axis

[Data type] Two-word

[Unit of data]	Increment system	IS-B	IS-C	Unit
	Millimeter machine	0.001	0.0001	mm
	Inch machine	0.0001	0.00001	inch

[Valid data range] -99999999 to 99999999

These parameters set the maximum point and minimum point of rectangle area 4 of group C in the second axis.

The set plane is specified with the group-A movement axes 1 and 2. Set the distances from the machine zero point to the maximum and minimum points.

Be sure to set a radius value regardless of whether the axis command is a diameter- or radius-programmed command.

If there is no relevant rectangle area, set 0.

Examples for setting parameters

Setting example for a lathe system

This function checks for interference among the tool post and chucks and stops the machine safely. Three major interference check areas can be set, each of which is specified by using rectangles. Two of the three interference check areas can be moved and rotated.

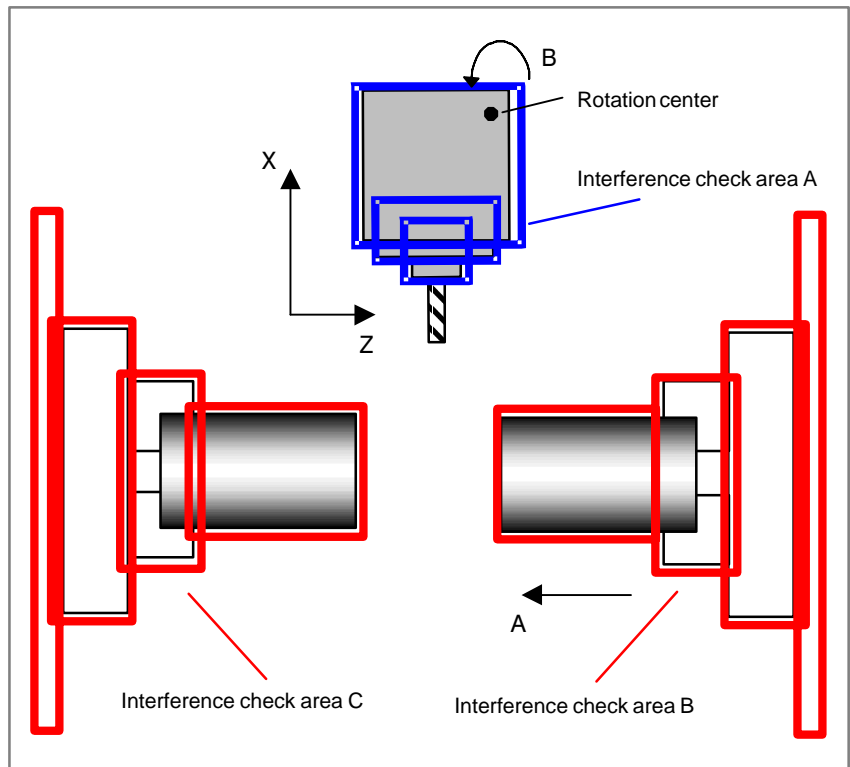

● CNC axis configuration

1st axis	X-axis	Axis along which check area A is moved
2nd axis	Z-axis	Axis along which check area A is moved
3rd axis	C-axis	
4th axis	Y-axis	
5th axis	B-axis	Axis on which check area A is rotated
6th axis	A-axis	Axis along which check area B is moved

● **Setting movement and rotation axes**

First axis for movement of area A: Z-axis Parameter No. 14910 = 2
 Second axis for movement of area A: X-axis Parameter No. 14911 = 1
 Rotation axis of area A: B-axis Parameter No. 14912 = 5
 First axis for movement of area B: A-axis Parameter No. 14913 = 6

● **Reference position return**

Perform reference position return along each axis.

● **Positioning of the rotation axis at the reference angular displacement**

Rotate the B-axis so that the sides of the rectangles of interference check area A are parallel to the X- and Z-axes.

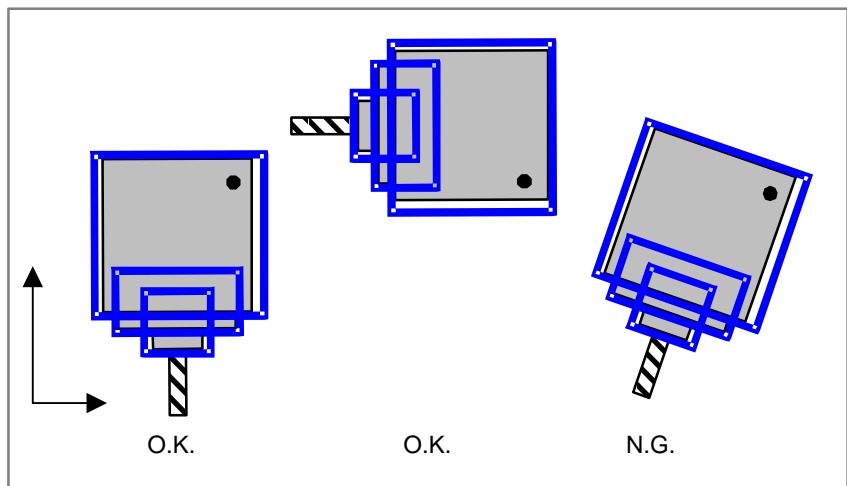

After determining the reference angular displacement of the B-axis, set the reference angular displacement in a parameter.

Reference angular displacement of area A
 Parameter No. 14938 = B-axis machine coordinate value

● **Rectangles that make up interference check area A**

After positioning the B-axis at the reference angular displacement and performing reference position return for the X- and Z-axes, set rectangles that make up interference check area A.

Interference check area A is represented by the following three rectangles:

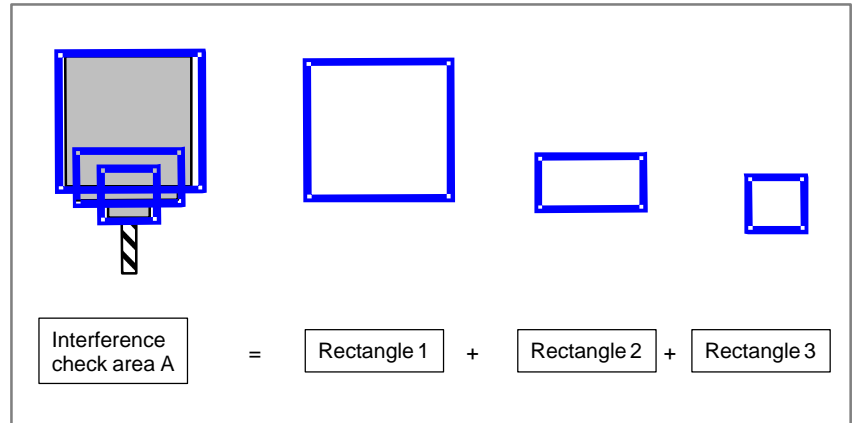

Let's take a look at rectangle 1 as an example. Measure the distances of the maximum and minimum points of rectangle 1 from the machine zero point.

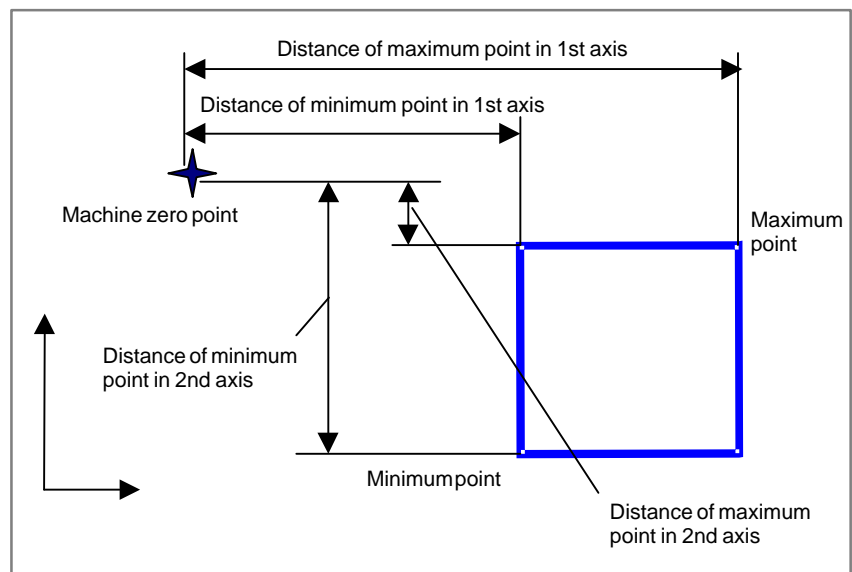

Parameter No. 14920 = Distance of maximum point of rectangle 1 in 1st axis

Parameter No. 14921 = Distance of minimum point of rectangle 1 in 1st axis

Parameter No. 14922 = Distance of maximum point of rectangle 1 in 2nd axis

Parameter No. 14923 = Distance of minimum point of rectangle 1 in 2nd axis

Similarly, measure the distances for rectangles 2 and 3.

Parameter No. 14924 = Distance of maximum point of rectangle 2
in 1st axis

Parameter No. 14925 = Distance of minimum point of rectangle 2
in 1st axis

Parameter No. 14926 = Distance of maximum point of rectangle 2
in 2nd axis

Parameter No. 14927 = Distance of minimum point of rectangle 2
in 2nd axis

Parameter No. 14928 = Distance of maximum point of rectangle 3
in 1st axis

Parameter No. 14929 = Distance of minimum point of rectangle 3
in 1st axis

Parameter No. 14930 = Distance of maximum point of rectangle 3
in 2nd axis

Parameter No. 14931 = Distance of minimum point of rectangle 3
in 2nd axis

When setting values, consider the distance of overrun due to the interference check processing time described later.

- **Rotation center of interference check area A**

In the same manner as rectangle data measurement, measure the rotation center point of interference check area A that is rotated on the B-axis.

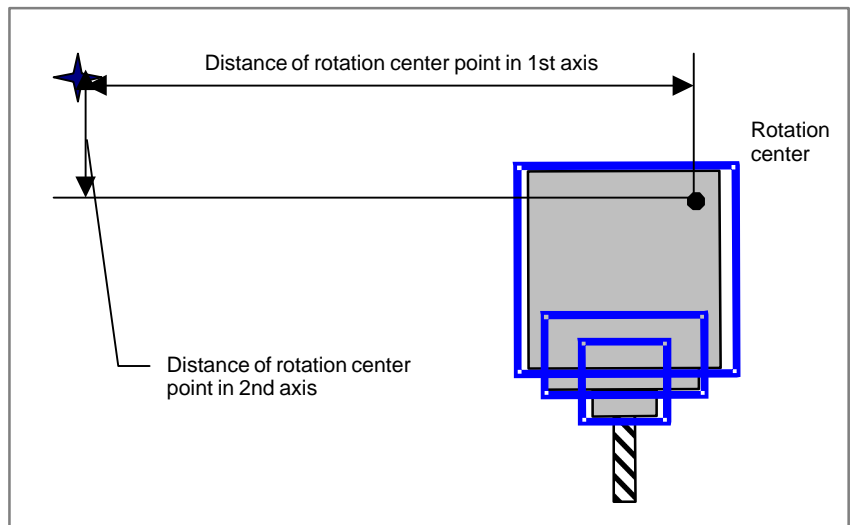

- **Setting interference check area B**

In the same manner as interference check area A, set interference check area B as follows. After performing reference position return along the A-axis, measure the rectangle data that makes up the interference check area, then set measured values in parameters. Like interference check area A, measure distances from the machine zero point.

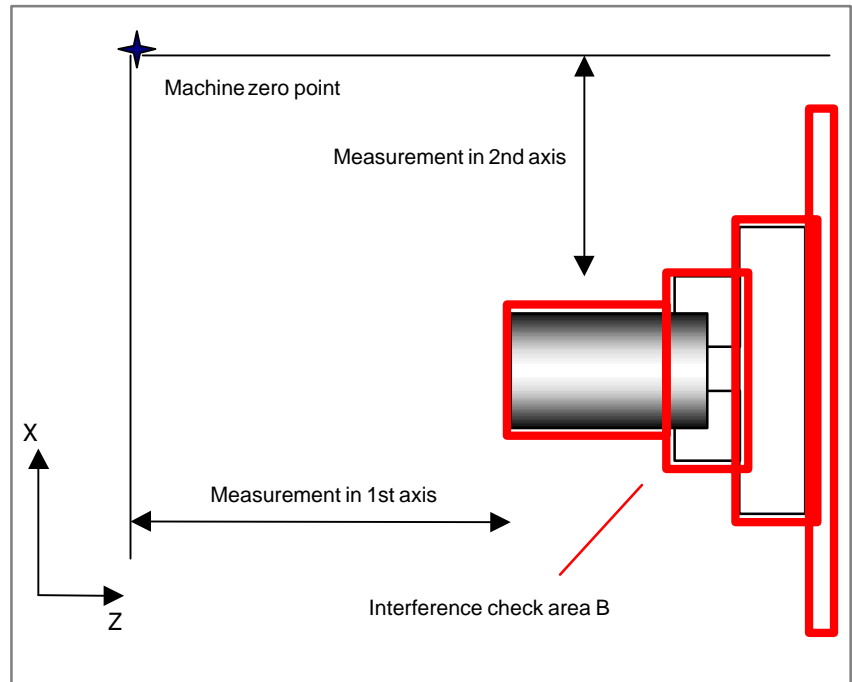

Parameter No. 14940 = Distance of maximum point of rectangle 1 in 1st axis

Parameter No. 14941 = Distance of minimum point of rectangle 1 in 1st axis

Parameter No. 14942 = Distance of maximum point of rectangle 1 in 2nd axis

Parameter No. 14943 = Distance of minimum point of rectangle 1 in 2nd axis

Parameter No. 14944 = Distance of maximum point of rectangle 2 in 1st axis

Parameter No. 14945 = Distance of minimum point of rectangle 2 in 1st axis

Parameter No. 14946 = Distance of maximum point of rectangle 2 in 2nd axis

Parameter No. 14947 = Distance of minimum point of rectangle 2 in 2nd axis

Parameter No. 14948 = Distance of maximum point of rectangle 3 in 1st axis

Parameter No. 14949 = Distance of minimum point of rectangle 3 in 1st axis

Parameter No. 14950 = Distance of maximum point of rectangle 3 in 2nd axis

Parameter No. 14951 = Distance of minimum point of rectangle 3 in 2nd axis

Parameter No. 14952 = Distance of maximum point of rectangle 4 in 1st axis

Parameter No. 14953 = Distance of minimum point of rectangle 4 in 1st axis

Parameter No. 14954 = Distance of maximum point of rectangle 4 in 2nd axis

Parameter No. 14955 = Distance of minimum point of rectangle 4 in 2nd axis

- **Movement direction of interference check area B**

Interference check area B can be moved along the A-axis. The A-axis corresponds to the Z-axis of interference check area A. In this example, the movement direction along the A-axis is opposite to the movement direction along the Z-axis.

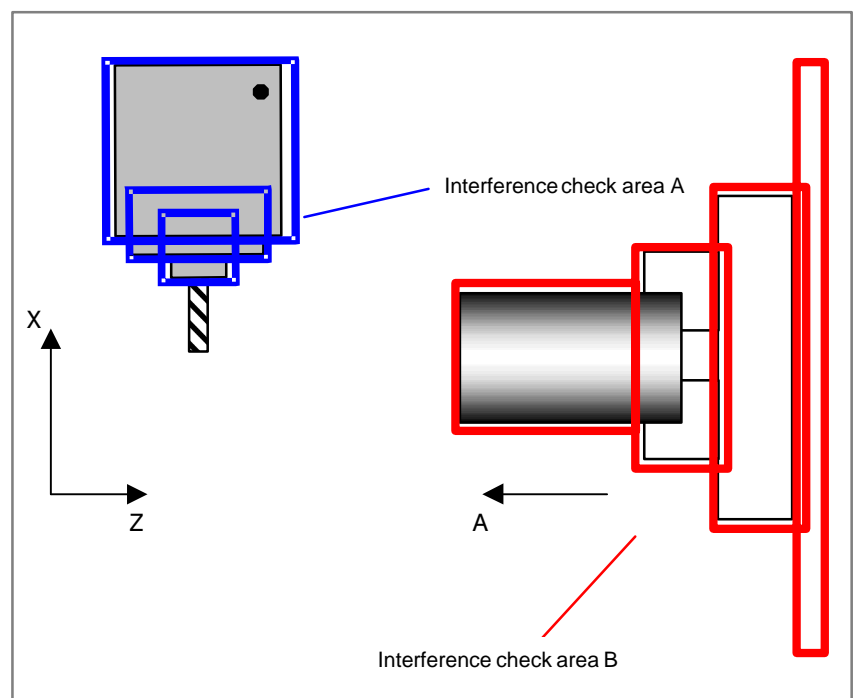

In this case, set bit 0 (IB1) of parameter No. 14900 to 1.

- IB1** 1: The direction of movement along the first axis of the group-B movement plane is opposite to the direction of movement along the first axis on the group-A movement plane.

- **Setting interference check area C**

In the same manner as interference check area A, set interference check area C as follows. Measure the rectangle data that makes up the interference check area, then set measured values in parameters. Like interference check area A, measure distances from the machine zero point.

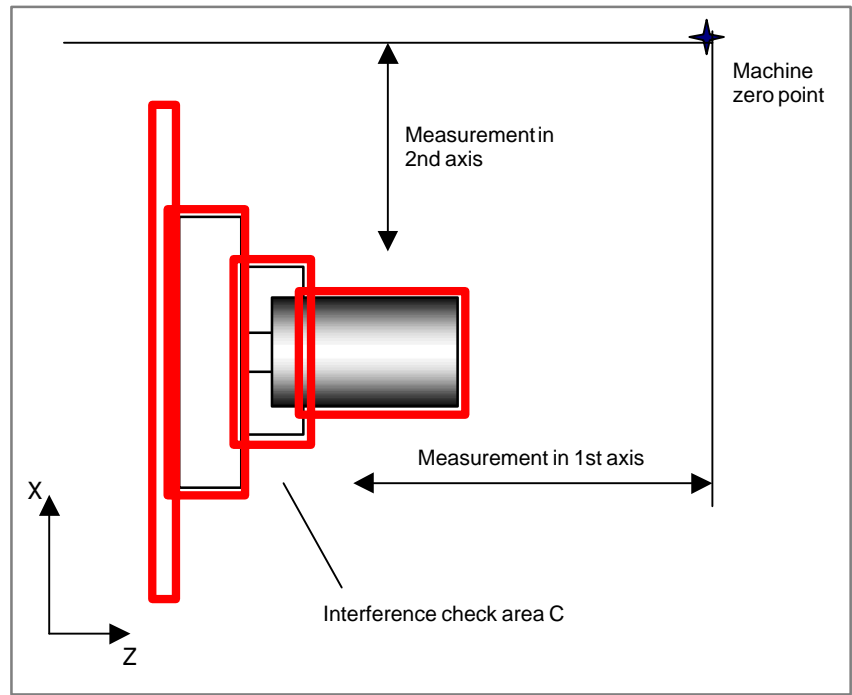

Parameter No. 14960 = Distance of maximum point of rectangle 1 in 1st axis

Parameter No. 14961 = Distance of minimum point of rectangle 1 in 1st axis

Parameter No. 14962 = Distance of maximum point of rectangle 1 in 2nd axis

Parameter No. 14963 = Distance of minimum point of rectangle 1 in 2nd axis

Parameter No. 14964 = Distance of maximum point of rectangle 2 in 1st axis

Parameter No. 14965 = Distance of minimum point of rectangle 2 in 1st axis

Parameter No. 14966 = Distance of maximum point of rectangle 2 in 2nd axis

Parameter No. 14967 = Distance of minimum point of rectangle 2 in 2nd axis

Parameter No. 14968 = Distance of maximum point of rectangle 3 in 1st axis

Parameter No. 14969 = Distance of minimum point of rectangle 3 in 1st axis

Parameter No. 14970 = Distance of maximum point of rectangle 3 in 2nd axis

Parameter No. 14971 = Distance of minimum point of rectangle 3 in 2nd axis

Parameter No. 14972 = Distance of maximum point of rectangle 4 in 1st axis

Parameter No. 14973 = Distance of minimum point of rectangle 4 in 1st axis

Parameter No. 14974 = Distance of maximum point of rectangle 4 in 2nd axis

Parameter No. 14975 = Distance of minimum point of rectangle 4 in 2nd axis

Setting example for a milling machine

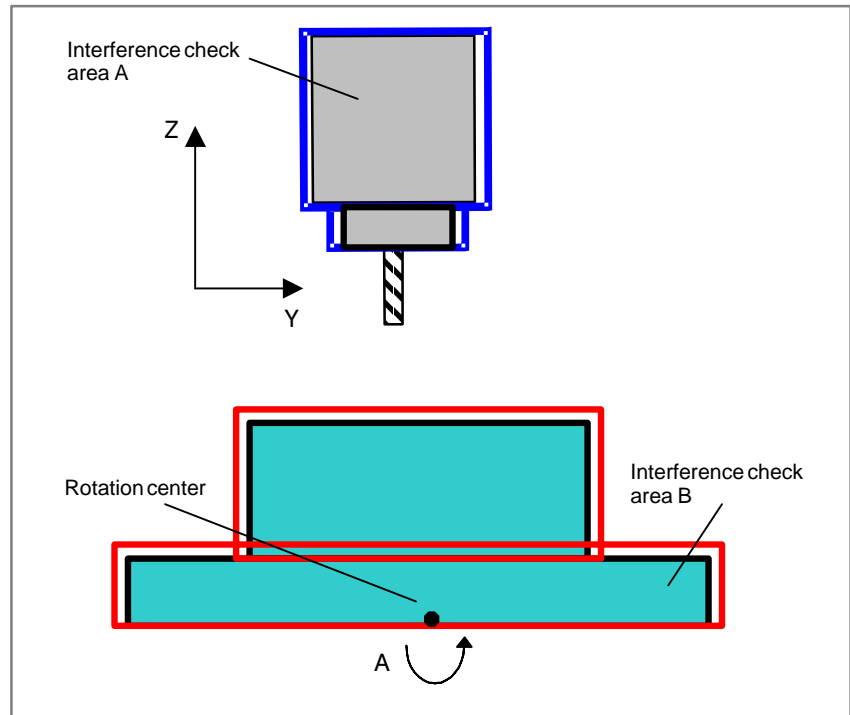

● CNC axis configuration

1st axis	X-axis	
2nd axis	Y-axis	Axis along which check area A is moved
3rd axis	Z-axis	Axis along which check area A is moved
4th axis	C-axis	
5th axis	A-axis	Axis on which check area B is rotated

● **Setting movement and rotation axes**

First axis for movement of area A: Y-axis Parameter No. 14910 = 2
 Second axis for movement of area A: Z-axis Parameter No. 14911 = 3
 Rotation axis of area B: A-axis Parameter No. 14915 = 5

● **Reference position return**

Perform reference position return along each axis.

- **Positioning of the rotation axis at the reference angular displacement**

Rotate the A-axis so that the sides of the rectangles of interference check area B are parallel to the Y- and Z-axes.

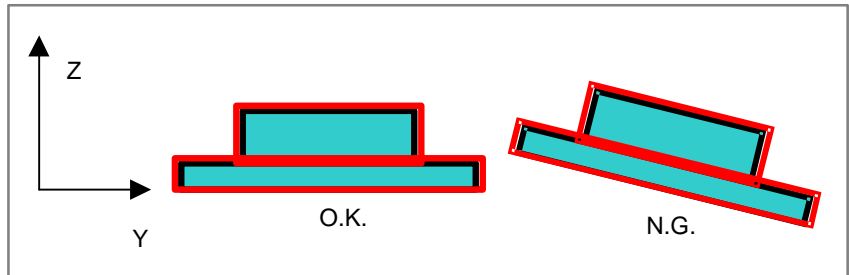

After determining the reference angular displacement of the A-axis, set the reference angular displacement in a parameter.

Reference angular displacement of area B

Parameter No. 14958 = A-axis machine coordinate value

- **Rectangles that make up interference check area A**

After performing reference position return along the Y- and Z-axes, set rectangles that make up interference check area A.

Interference check area A is represented by the following two rectangles:

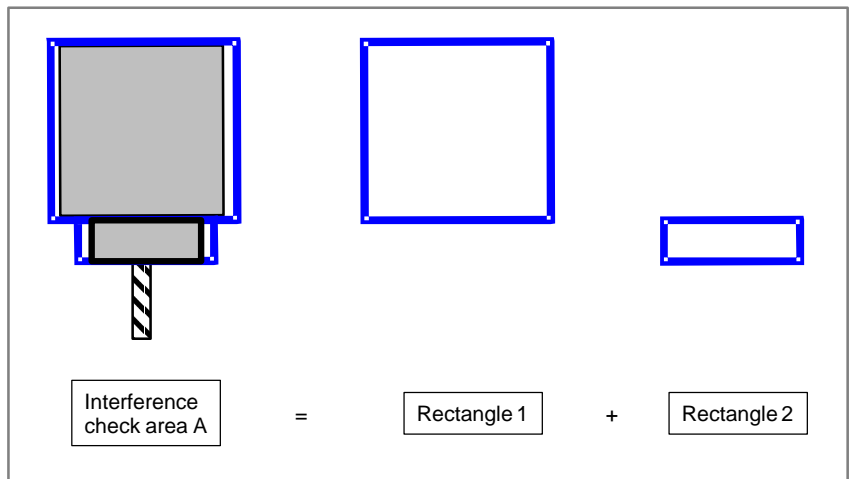

Let's take a look at rectangle 1 as an example. Measure the distances of the maximum and minimum points of rectangle 1 from the machine zero point.

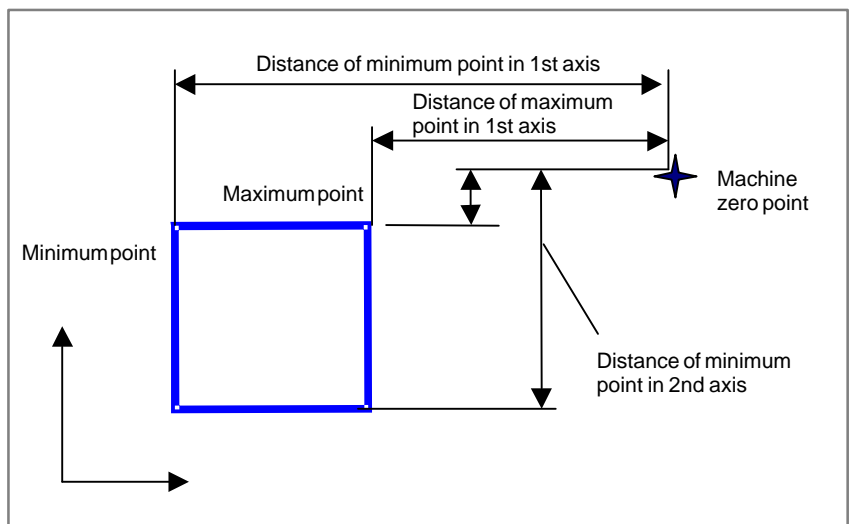

Parameter No. 14920 = Distance of maximum point of rectangle 1 in 1st axis

Parameter No. 14921 = Distance of minimum point of rectangle 1 in 1st axis

Parameter No. 14922 = Distance of maximum point of rectangle 1 in 2nd axis

Parameter No. 14923 = Distance of minimum point of rectangle 1 in 2nd axis

Similarly, measure the distances for rectangle 2.

Parameter No. 14924 = Distance of maximum point of rectangle 2 in 1st axis

Parameter No. 14925 = Distance of minimum point of rectangle 2 in 1st axis

Parameter No. 14926 = Distance of maximum point of rectangle 2 in 2nd axis

Parameter No. 14927 = Distance of minimum point of rectangle 2 in 2nd axis

When setting values, consider the distance of overrun due to the interference check processing time described later.

- **Setting interference check area B**

With the A-axis positioned at the reference angular displacement, set interference check area B in the same manner as interference check area A as follows. Measure rectangle data that makes up the interference check area, and set measured values in parameters. Like interference check area A, measure distances from the machine zero point.

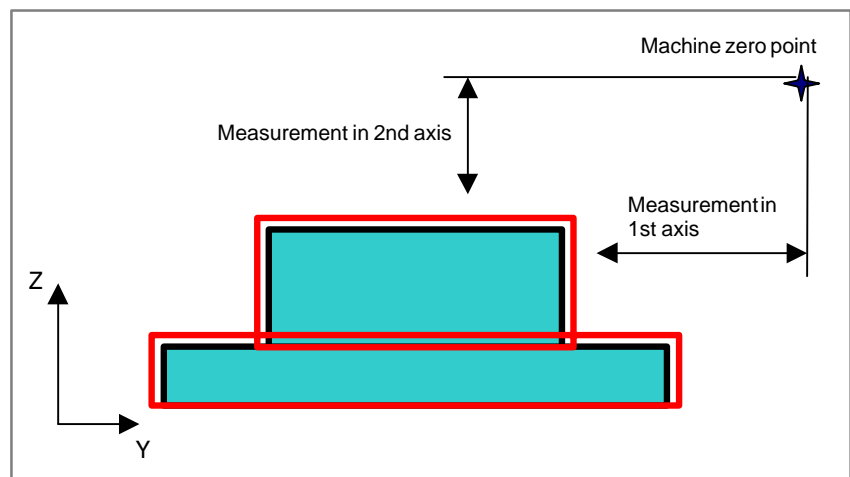

Parameter No. 14940 = Distance of maximum point of rectangle 1 in 1st axis

Parameter No. 14941 = Distance of minimum point of rectangle 1 in 1st axis

Parameter No. 14942 = Distance of maximum point of rectangle 1 in 2nd axis

Parameter No. 14943 = Distance of minimum point of rectangle 1 in 2nd axis

Parameter No. 14944 = Distance of maximum point of rectangle 2 in 1st axis

Parameter No. 14945 = Distance of minimum point of rectangle 2 in 1st axis

Parameter No. 14946 = Distance of maximum point of rectangle 2 in 2nd axis

Parameter No. 14947 = Distance of minimum point of rectangle 2 in 2nd axis

- **Rotation center of interference check area B**

In the same manner as rectangle data measurement, measure the center point of interference check area B that is rotated on the A-axis.

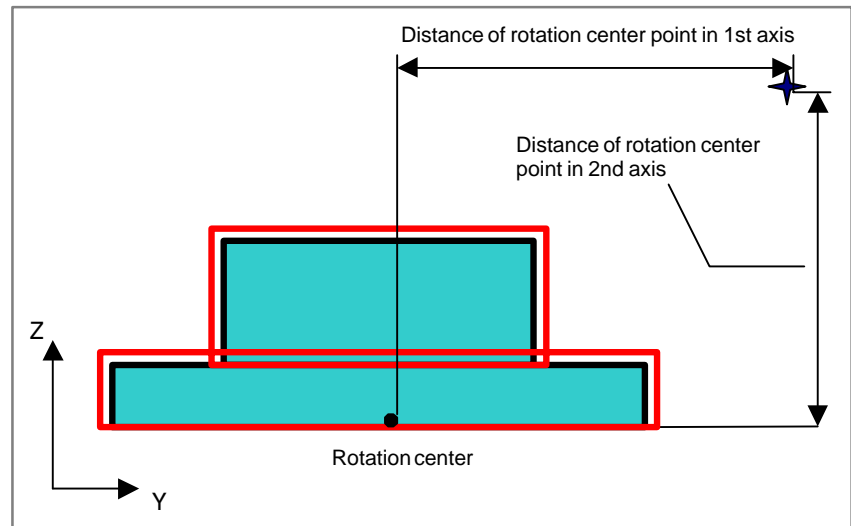

Parameter No. 14956 = Rotation center in the first axis when area B is rotated

Parameter No. 14957 = Rotation center in the second axis when area B is rotated

- **Calculating the overrun distance**

This function makes interference checks based on the position information obtained after pulse distribution, so there is an overrun distance when the machine is stopped by an alarm. Furthermore, because of the CNC processing capability, this function cannot check all interference patterns in each distribution period. As a result, while the function checks all interference patterns, there is an idle run distance (overrun distance).

The overrun distance is obtained as follows:

Suppose bits 4 to 7 (IC1 to IC4) of parameter No. 14900 be 0. (Setting: 16)

Interference check processing time =

$$((3 \times 4) + (3 \times 4) + (4 \times 4)) \div (\text{setting in IC1 to IC4}) \times 8$$

$$= (12 + 12 + 16) \div 16 \times 8 = 20$$

Round the result upward to a multiple of 8 24 [msec]

Interference check overrun distance =

$$\text{rapid traverse rate} \div 60 \times \text{interference check processing time}$$

$$= 30000 \div 60 \times 24 = 12000 [0.001 \text{ mm}]$$

This function performs processing within a CNC distribution period. As the value set in IC1 to IC4 becomes larger, processing within the CNC distribution period increases. This can affect program command preprocessing and screen display processing, resulting in delay in such processing.

As a guideline, set IC1 to IC4 to 16, and make adjustments as necessary.

Alarm and message

Number	Message	Description
514	INTERFERENCE : +n	The rotation area interference check function found interference on the plus side of the n axis.
515	INTERFERENCE : -n	The rotation area interference check function found interference on the minus side of the n axis.

2.4 ALARM SIGNAL

General

When an alarm is triggered in the CNC, the alarm is displayed on the screen, and the alarm signal is set to 1.

If the voltage level of the memory backup battery falls to below a specified level while the CNC is turned off, the battery alarm signal is set to 1.

Signal

Alarm signal AL<F001#0>

[Classification] Output signal

[Function] The alarm signal reports that the CNC is in an alarm state.

The following are the alarms that may be issued:

- (a) TH alarm
- (b) TV alarm
- (c) P/S alarm
- (d) Overtravel alarm
- (e) Overheat alarm
- (f) Servo alarm

[Output condition] The alarm signal is set to 1 when:

- The CNC is placed in the alarm state.

The alarm signal is set to 0 when:

- The alarm has been released by resetting the CNC.

Battery alarm signal BAL<F001#2>

[Classification] Output signal

[Function] The battery alarm signal indicates that the voltage of the battery for the memory has fallen to below a specified level while the CNC is off. In general, this signal is used to turn on an LED to notify the operator.

[Output condition] The signal is set to 1 when:

- The battery voltage has fallen to below the specified level.

The signal is set to 0 when:

- The battery voltage has risen to the specified level or higher.

Signal address

	#7	#6	#5	#4	#3	#2	#1	#0
F001						BAL		AL

Parameter

	#7	#6	#5	#4	#3	#2	#1	#0
3111	NPA							

[Data type] Bit

NPA Action taken when an alarm is generated or when an operator message is entered

0 : The display shifts to the alarm or message screen.

1 : The display does not shift to the alarm or message screen.

2.5 START LOCK/ INTERLOCK

General

These signals disable machine movement along axes. When any of these signals is activated during movement, tool movement along the affected axis (or axes) is decelerated, then stopped.

Signal

Start lock signal STLK<G007#1>(T series)

[Classification] Input signal

[Function] This signal disables machine movement along all axes subject to automatic operation (memory or MDI operation).

[Operation] When the STLK signal turns to “1”, the axis movement is decelerated and stopped.

In automatic operation, blocks containing M, S, T, or B commands or 2nd auxiliary function are executed consecutively until a block containing an axis move command is encountered; the movement then stops and the CNC is placed in automatic operation mode (STL is “1”, SPL is “0”). When the STLK signal turns to “0”, operation restarts. (Figs. 2.5 (a), (b)).

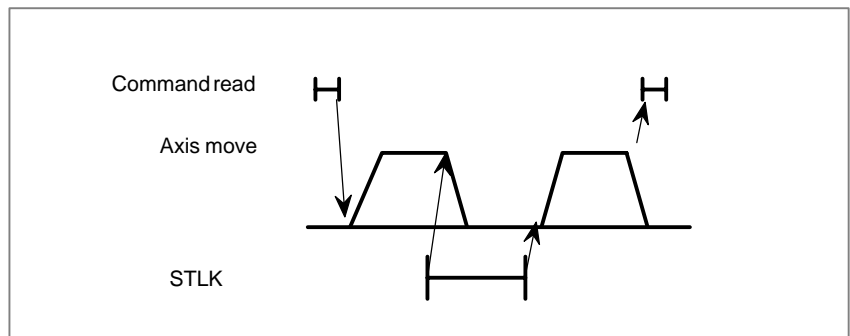

Fig. 2.5 (a) Block containing axis move commands only

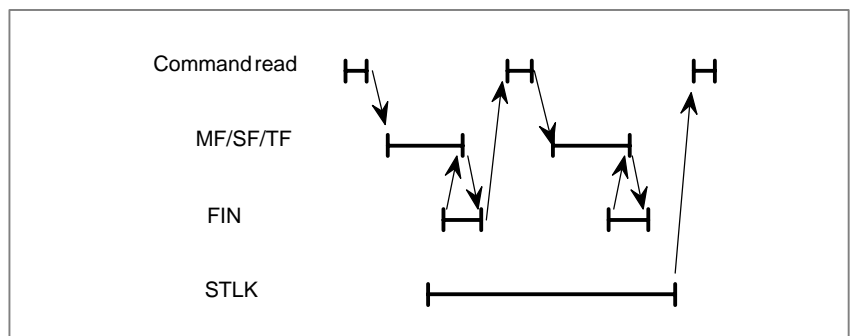
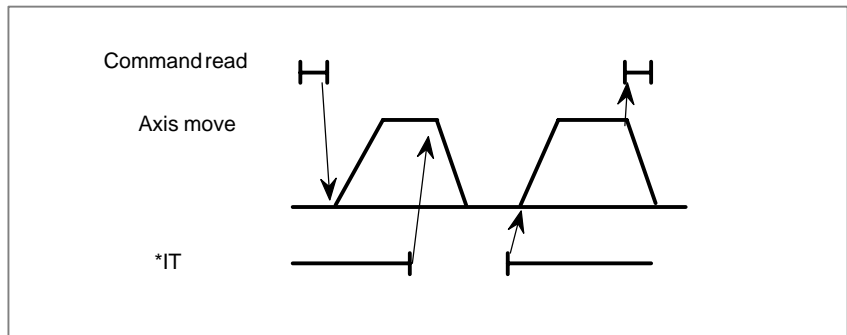
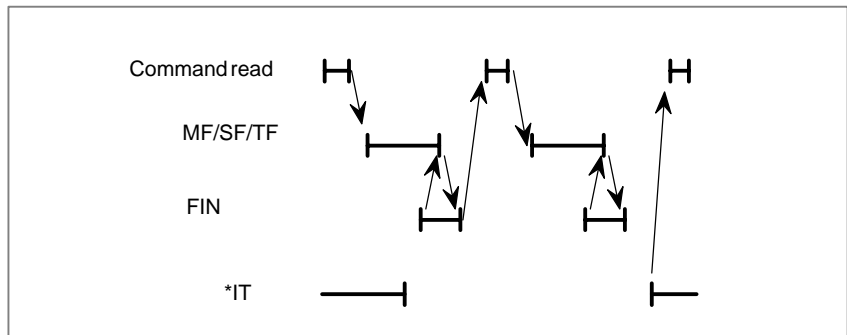

Fig. 2.5 (b) Block containing only auxiliary functions only

All axes Interlock signal***IT<G008#0>****[Classification]** Input signal**[Function]** This signal is used to inhibit the machine from moving, and is effective regardless of the selected mode.**[Operation]** When the *IT signal is "0", the axis movement is decelerated and stopped. In automatic operation, blocks containing M, S, T or B 2nd auxiliary mode commands are executed consecutively until a block containing an axis move command is encountered; the system then stops and is placed into the automatic operation mode (cycle start lamp signal STL is "1", feed hold lamp signal SPL is "0"). When the *IT signal turns to "1", operation resumes (Figs. 2.5(c), (d)).**Fig. 2.5 (c) Block containing axis move commands only (manual and automatic operation)****Fig. 2.5 (d) Block containing auxiliary functions only (automatic operation)****NOTE**

The overtravel distance of the motor after turning *IT to "0" is represented by the following formula.

$$Q_{\max} = F_m \cdot \frac{1}{60} \times \left(\frac{T_c}{1000} + \frac{T_s}{1000} + \frac{A}{1000} \right)$$

Where

- Q_{\max} : Overtravel quantity (mm or inch)
- F_m : Feedrate (mm/min or inch/min)
- T_c : Cutting time constant (ms)
- T_s : Servo time constant ($T_s = 33\text{ms}$ normally)
- A : Processing time of CNC
- $A = 50\text{ms}$

Interlock signal for each axis

*IT1 to *IT8<G130>

[Classification] Input signal

[Function] These signals disable feed along axes on an axis-by-axis basis. A separate interlock signal is provided for each controlled axis. The number at the end of each signal name denotes the number of the corresponding controlled axis.

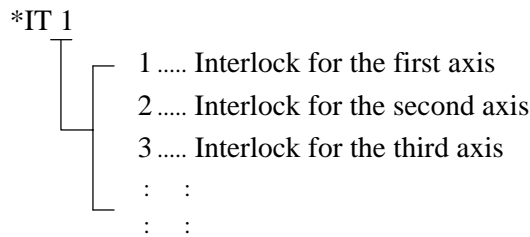

[Operation] a) In manual operation

The movement of an interlocked axis is inhibited, but the other axes are movable. If an axis is interlocked during movement, it stops after being decelerated, and it starts moving again when it is released from interlock.

b) In automatic operation (MEM RMT or MDI mode)

If an axis is interlocked while its movement is being commanded (the move amount is not 0, inclusive of the tool offset), movement in all axes is prevented.

If a moving axis is interlocked, all axes stop moving after being decelerated, and they start moving again when interlock is released.

This function is also effective during dry run.

Interlock signal for each axis and direction

+MIT1, -MIT1, +MIT2, -MIT2,

+MIT3, -MIT3, +MIT4, -MIT4,

+MIT5, -MIT5, +MIT6, -MIT6,

+MIT7, -MIT7, +MIT8, -MIT8

<G132#0 to #7, G134#0 to

#7> (M series)

+MIT1, -MIT1, +MIT2, -MIT2

<X004#2~X004#5>(T series)

[Classification] Input signal

[Function] This function allows a directional interlock for each axis.

[Operation] When the axis/directional interlock signal becomes “1”, CNC applies interlock only in the corresponding axial direction. However, during automatic operation, all axes will stop.

NOTE

In the T series, when bit 4 (DAU) of parameter No. 3003 is 0, a directional interlock for each axis is applied only during manual operation. To allow a directional interlock for each axis also during automatic operation, set bit 4 (DAU) of parameter No. 3003 to 1.

Block start interlock signal***BSL<G008#3>**

[Classification] Input signal

[Function] This signal disables the start of the next block during automatic operation

[Operation] While this signal is 0, the execution of the next block during automatic operation is not started. This signal does not affect a block that has already started, and that block is continuously executed until its end. This signal does not halt automatic operation. The command in the next block is ready for execution as a valid command, so execution restarts as soon as the signal is set to 1.

NOTE

When blocks for cycle operation are internally created by a canned cycle and so on, only the first block is generally interlocked by this signal. The intermediate blocks are executed continuously even if this signal is set to 0.

Cutting block start interlock signal***CSL<G008#1>**

[Classification] Input signal

[Function] This signal disables the start of blocks specifying move commands other than positioning during automatic operation.

[Operation] While this signal is 0, the execution of blocks specifying movement other than positioning during automatic operation is not started. This signal does not affect a block that has already started, and that block is continuously executed until its end. This signal does not halt automatic operation. The command in the next block is ready for execution as a valid command, so execution restarts as soon as the signal is set to 1.

[Usage] When the spindle has been specified, or when the spindle speed has been changed, this signal can be held 0 until a target spindle speed is achieved. Then, the next cutting block can be executed at the target spindle speed.

NOTE

This signal is effective for any blocks including blocks for cycle operation internally created by a canned cycle and so on.

Signal address

	#7	#6	#5	#4	#3	#2	#1	#0
G007							STLK	
G008					*BSL		*CSL	*IT
G130	*IT8	*IT7	*IT6	*IT5	*IT4	*IT3	*IT2	*IT1
G132	+MIT8	+MIT7	+MIT6	+MIT5	+MIT4	+MIT3	+MIT2	+MIT1
G134	-MIT8	-MIT7	-MIT6	-MIT5	-MIT4	-MIT3	-MIT2	-MIT1
X004			-MIT2	+MIT2	-MIT1	+MIT1		

Parameter

	#7	#6	#5	#4	#3	#2	#1	#0
3003				DAU	DIT	ITX		ITL
					DIT	ITX		ITL

[Data type] Bit

ITL Interlock signal

0 : Enabled

1 : Disabled

ITX Interlock signals for each axis

0 : Enabled

1 : Disabled

DIT Interlock for each axis direction

0 : Enabled

1 : Disabled

DAU If bit 3 (DIT) of parameter No. 3003 is set to 0, the interlock signal of each axial direction is:

0 : Enabled only in manual operation and disabled in automatic operation.

1 : Enabled in both manual operation and automatic operation.

	#7	#6	#5	#4	#3	#2	#1	#0
3004							BCY	BSL

[Data type] Bit

BSL The block start interlock signal *BSL and cutting block start interlock signal *CSL are:

0 : Disabled.

1 : Enabled.

BCY When more than one operation is performed by one block command such as a canned cycle, the block start interlock signal *BSL is:

0 : Checked only at the beginning of the first cycle.

1 : Checked at the beginning of every cycle.

Note**NOTE**

The interlock signal for each axis and direction (T series) is supported regardless of whether the direct input of tool offset value measurement B is provided.

2.6 MODE SELECTION

General

The mode select signal is a code signal consisting of the three bits MD1, MD2, and MD4.

The following seven modes can be selected.

- Memory edit (EDIT)
- Memory operation (MEM)
- Manual data input (MDI)
- Manual handle/incremental feed (HANDLE/INC)
- Manual continuous feed (JOG)
- TEACH IN JOG
- TEACH IN HANDLE

And in addition, DNC operation mode can be selected by combining the (MEM) mode setting and the DNCI signal. Manual reference position return mode can be selected by combining the manual continuous feed (JOG) mode setting and the ZRN signal.

The currently selected operation mode can be posted by outputting the operation mode check signal.

Signal

Mode selection signal

MDI, MD2, MD4

<G043#0 to #2>

DNCI <G043#5>

ZRN <G043#7>

[Classification] Input signal

[Operation] As shown in the following table, the mode select signal is a grey code (a code in which only one bit is different from that of the adjacent mode). To prevent faulty mode switching, use an overcrossing contact rotary switch so that only one bit changes from that of the adjacent mode. An example of "Faulty mode switching" would be:

When the mode is switched to the EDIT mode during memory operation, the CNC enters the single block state and the operation stops at the end of the executing block.

For this example mode switching, only MD2 should change from 0 to 1. However if a transient signal status change were to occur in a signal other than MD2 during mode switching, another mode (manual continuous feed mode, for example) would be set between automatic operation mode and memory edit mode. When manual continuous feed mode is set while the CNC is in automatic status, the CNC immediately stops memory operation. As a result, although the operator intended to switch the mode to the memory edit mode, the transient signal caused the CNC to be placed in feed hold state instead.

	Mode	Signal status				
		MD4	MD2	MD1	DNCI	ZRN
1	Memory edit (EDIT)	0	1	1	0	0
2	Memory operation (MEN)	0	0	1	0	0
3	Manual data input (MDI)	0	0	0	0	0
4	Manual handle/incremental feed (HANDLE/INC)	1	0	0	0	0
5	Manual continuous feed (JOG)	1	0	1	0	0
6	TEACH IN HANDLE (THND)	1	1	1	0	0
7	TEACH IN JOG (TJOG)	1	1	0	0	0
8	DNC operation (RMT)	0	0	1	1	0
9	Manual reference position return (REF)	1	0	1	0	1

Operation mode check signal
MMDI, MMEM , MRMT,
MEDT, MH, MINC, MJ,
MREF, MTCHIN
<F003, F004#6>

[Classification] Output signal

[Function] The currently selected operation mode is output.

[Operation] The following lists the relationship between the mode selection signals and check signals:

Mode		Input signal					Output signal
		MD4	MD2	MD1	DNC I	ZRN	
Automatic operation	Manual data input (MDI) (MDI operation)	0	0	0	0	0	MMDI<F003#3>
	Memory operation (MEM)	0	0	1	0	0	MMEM<F003#5>
	DNC operation (RMT)	0	0	1	1	0	MRMT<F003#4>
Memory edition (EDIT)		0	1	1	0	0	MEDT<F003#6>
Manual operation	Manual handle feed / Incremental feed (HANDLE/INC)	1	0	0	0	0	MH<F003#1> MINC<F003#0>
	Manual continuous feed (JOG)	1	0	1	0	0	MJ<F003#2>
	Manual reference position return (REF)	1	0	1	0	1	MREF<F004#5>
	TEACH IN JOG (TJOG)	1	1	0	0	0	MTCHIN<F003#7>, MJ<F003#2>
	TEACH IN HANDLE (THND)	1	1	1	0	0	MTCHIN<F003#7>, MH<F003#1>

Signal address

	#7	#6	#5	#4	#3	#2	#1	#0
G043	ZRN		DNCI			MD4	MD2	MD1
	#7	#6	#5	#4	#3	#2	#1	#0
F003	MTCHIN	MEDT	MMEM	MRMT	MMDI	MJ	MH	MINC
F004			MREF					

Note**NOTE**

Precautions on modes and mode switching

- 1 In MDI mode, the STL signal turns to "0" and the CNC stops as soon as the commands entered via the MDI have been executed. But the SPL signal does not turn to "1". Therefore, another command can be entered from the manual data input unit under this condition.
- 2 Manual operation in jog feed mode
 - a) When bit 0 (JHD) of parameter No. 7100 is set to 0
Only jog feed is possible.
 - b) When bit 0 (JHD) of parameter No. 7100 is set to 1
Both jog feed and manual handle feed are possible, provided the manual handle feed option is installed. Jog feed and manual handle feed cannot, however, be performed simultaneously. Manual handle feed can be performed when the tool is not being moved by means of jog feed.
- 3 Manual operation in manual handle/incremental feed and TEACH IN HANDLE mode.
 - a) Incremental feed is possible, provided the manual handle feed is not installed.
 - b) Incremental feed is possible, provided the manual handle feed is installed.
 - i) When bit 0 (JHD) of parameter No. 7100 is set to 0
Only manual handle feed is possible.
 - ii) When bit 0 (JHD) of parameter No. 7100 is set to 1
Manual handle feed and incremental feed is possible. Manual handle feed and incremental feed cannot, however, be performed simultaneously. Manual handle feed can be performed when the tool is not being moved by means of incremental feed.

NOTE**4 Manual operation in TEACH IN JOG mode**

a) When bit 1 (THD) of parameter No. 7100 is set to 0

Only jog feed is possible.

b) When bit 1 (THD) of parameter No. 7100 is set to 1

Both jog feed and manual handle feed are possible, provided the manual handle feed option is installed. Jog feed and manual handle feed cannot, however, be performed simultaneously. Manual handle feed can be performed when the tool is not being moved by means of jog feed.

5 When switching to manual data input mode is made during operation in memory operation mode, the CNC enters the automatic operation stop state after executing the command in the current block. Signal STL is then set to 0. In this case, signal SPL is not set to 1 ((a) in Fig. 2.6). When switching to memory operation mode is made during operation in manual data input mode, the CNC enters memory operation mode after executing the currently executed command ((b) in Fig. 2.6).

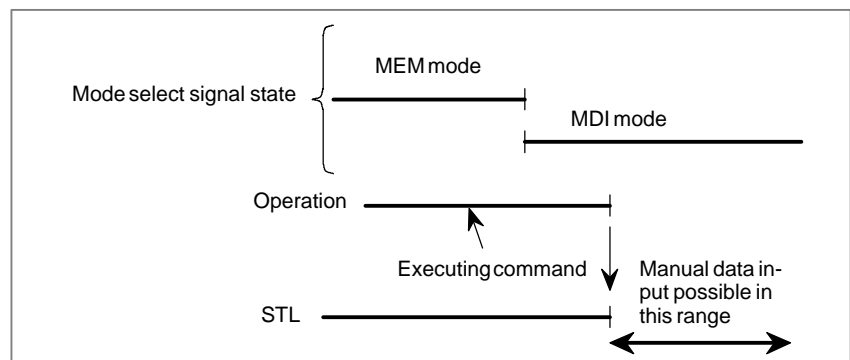
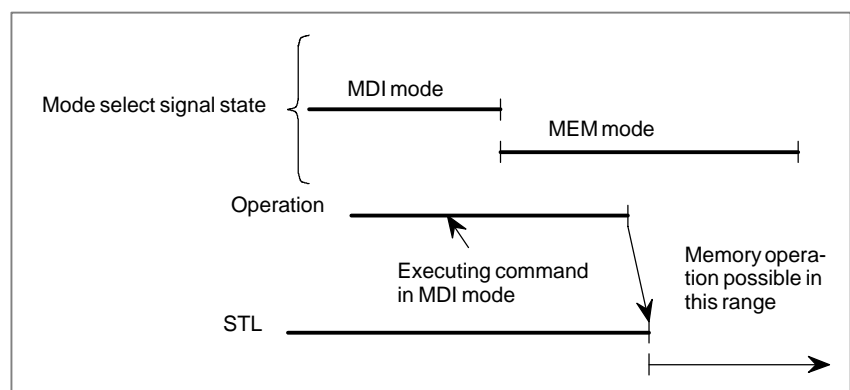
**Fig. 2.6 (a)****Fig. 2.6 (b)**

NOTE

6 When the HANDLE/INC or TEACH IN HANDLE mode is selected while the CNC is operating in the MEM or MDI mode, the automatic or MDI operation stops, the STL signal turns to “0”, the SPL signal simultaneously turns to “1”, and the CNC enters the HANDLE/INC or TEACH IN HANDLE mode. Under these conditions, manual handle feed or incremental feed by axis direction select signal is permitted. Since the MEM mode or MDI mode commands are held, operation can be restarted by the cycle start signal and by selecting the MDI or MEM mode. However, if operation was stopped by switching to the HANDLE/INC or TEACH IN HANDLE mode during manual data input or during automatic operation, it can be restarted only by reactivating the mode in use before the operation was stopped (Fig. 2.6 (c)).

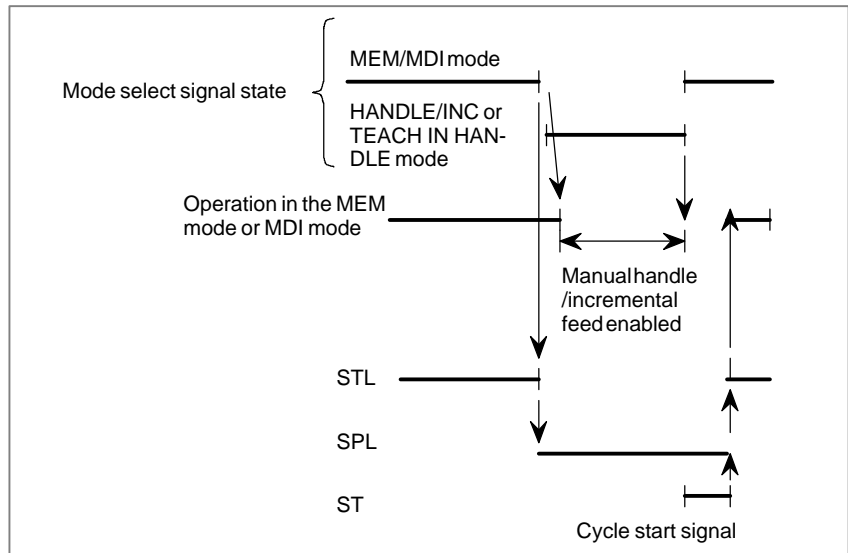

Fig. 2.6 (c)

NOTE

7 When the JOG or TEACH IN JOG mode is selected during RMT, MEM or MDI mode operation, operation stops, the STL signal turns to “0”, the SPL signal simultaneously turns to “1”, and the CNC enters the JOG or TEACH IN JOG mode. Under these conditions, manual feed by feed axis direction select signal is permitted. Operation can be restarted by returning to the original mode, as described for HANDLE/STEP or TEACH IN HANDLE mode (Fig. 2.6 (d)). When the mode is switched to the JOG or TEACH IN JOG mode during manual handle feed or during step feed operation, the CNC ignores the manual handle feed or step feed command and manual jog feed becomes effective. If a feed axis direction select signal turns to “1” before the JOG or TEACH IN JOG mode is selected, that signal is ignored. The feed axis select signal is selected by turning the necessary feed axis direction signal to “1” after turning all the feed axis direction select signals to “0” (Fig. 2.6 (e)). It is possible to perform handle feed in TEACH IN JOG mode by activating parameter THD no.7100#1. For details, refer to item (2), (4).

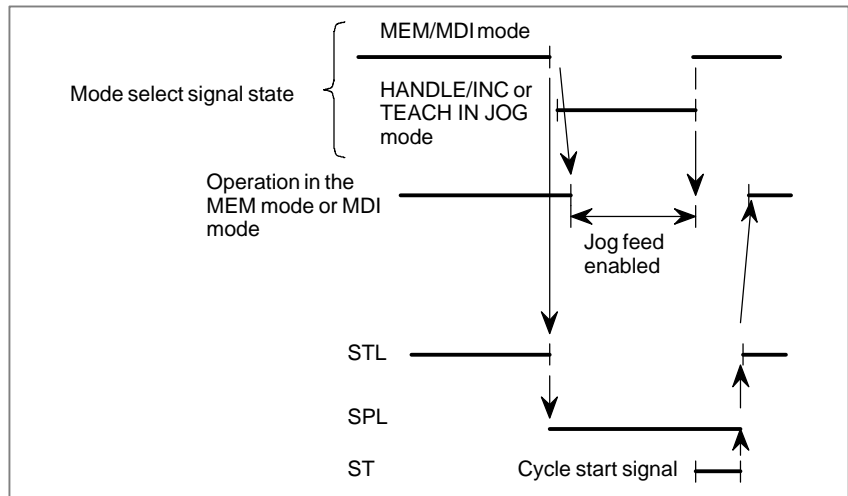

Fig. 2.6 (d)

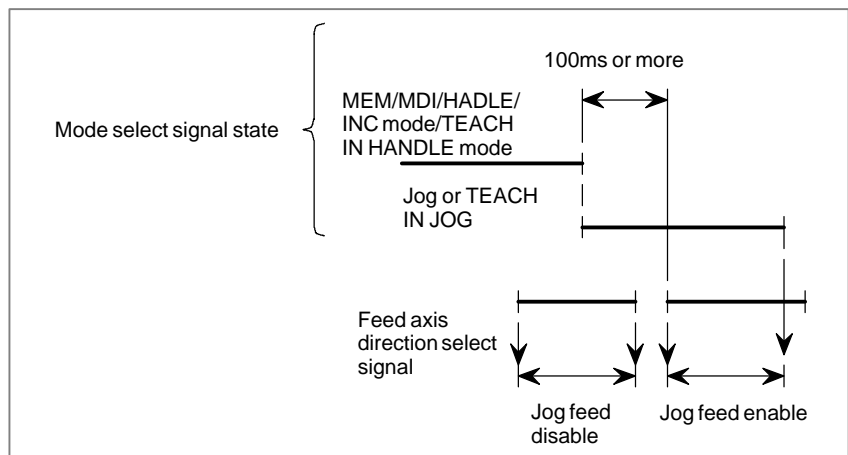

Fig. 2.6 (e)

NOTE

8 The mode switching operation is summarized in the time chart below (Fig. 2.6 (f)).

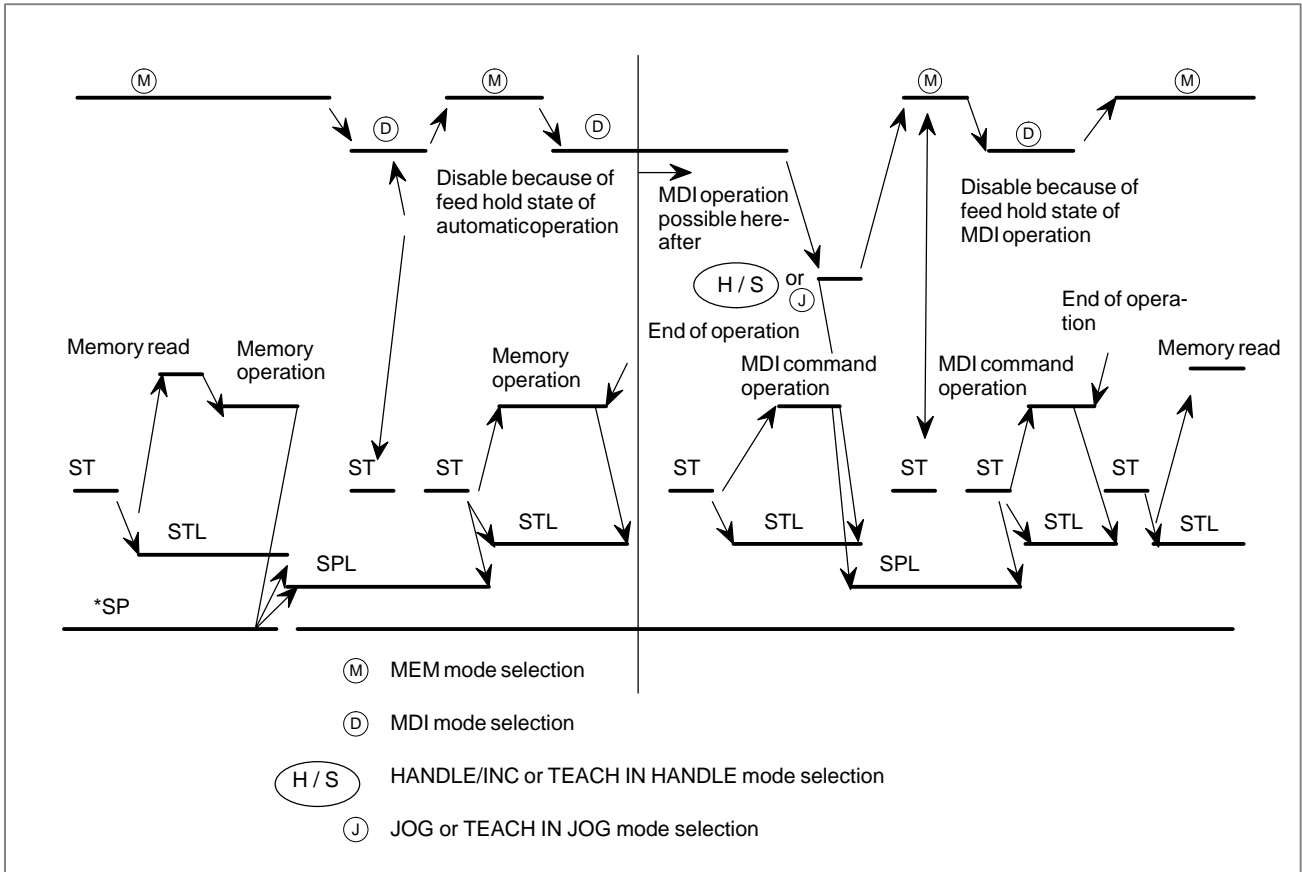

Fig. 2.6 (f) Mode signal time chart

Reference item

CONNECTION MANUAL (This manual)	4.1	Manual Reference Position Return
------------------------------------	-----	----------------------------------

2.7 PATH SELECTION/ DISPLAY OF OPTIONAL PATH NAMES (TWO-PATH CONTROL)

General

Path selection specifies whether operations performed using the MDI panel are for path 1 or path 2.

The operations, as used here, include displaying and setting data items (such as tool compensation values), entering command programs in MDI mode, and editing machining programs in program memory.

Also note that the name of each path can be changed by parameter.

Signal

Path selection signal (Tool post selection signal) HEAD<G063#0>

[Classification] Input signal

[Function] Selects whether the MDI panel is used for path 1 or path 2.

[Operation] When this signal turned to "1", operations performed using the MDI panel are for path 2.

When this signal turned to "0", operations performed using the MDI panel are for path 1.

Signal address

	#7	#6	#5	#4	#3	#2	#1	#0
G063								HEAD

Parameter

	#7	#6	#5	#4	#3	#2	#1	#0
8100							IAL	RST

[Data type] Bit

RST Reset key on the MDI panel

0 : Effective for both paths

1 : Effective only for that path selected by the path select signal

IAL When an alarm is raised in one tool post in automatic operation mode,

0 : The other path enters the feed hold state and stops.

1 : The other path continues operation without stopping.

Parameters for display of optional path names

3141	Path name (1st character)
3142	Path name (2nd character)
3143	Path name (3rd character)
3144	Path name (4th character)
3145	Path name (5th character)
3146	Path name (6th character)
3147	Path name (7th character)

[Data type] Byte type

Specify a path name with codes (two-path control).

Any character string consisting of alphanumeric characters and symbols (up to seven characters) can be displayed as path names on the screen, instead of HEAD1 and HEAD2 for T series, and instead of PATH1 and PATH2 for M series.

NOTE

- 1 This parameter is dedicated to the two-path control.
- 2 Specify these parameters for each series.
- 3 For characters and codes, see the corresponding table in 2.1.15 software operator's panel.
- 4 When codes are 0, HEAD1 and HEAD2 for T series and PATH1 or PATH2 for M series are displayed.

2.8 STATUS OUTPUT SIGNAL

General

The table below lists the status output signals. They indicate the state of the CNC. See the sections listed in the table for details of each signal.

Signal name	Symbol	Reference section
Alarm signal	AL	2.4
Battery alarm signal	BAL	2.4
Reset signal	RST	5.2
Rewinding signal	RWD	5.2
Tapping signal	TAP	11.7
Moving signal	MV1 – MV8	1.2.5
Moving direction signals	MVD1 – MVD8	1.2.5
In-position signals	INP1 – INP8	7.2.6.1
Rapid traversing signal	RPDO	2.8 (the section you are reading)
Cutting feed signal	CUT	2.8 (the section you are reading)
Thread cutting signal	THRD	6.4.1
Constant surface speed signal	CSS	9.5
Inch input signal	INCH	11.4

Signal

Rapid traversing signal RPDO <F002#1>

[Classification] Output signal

[Function] This signal indicates that a move command is being executed at rapid traverse.

[Output condition] “1” indicates an axis starts moving after rapid traverse has been selected; “0” indicates that an axis starts moving after a feedrate other than rapid traverse has been selected. This holds true for both automatic and manual operation modes.

NOTE

- 1 Rapid traverse in automatic operation includes all rapid traverses in canned cycle positioning, automatic reference point return, etc., as well as the move command G00. Rapid traverse in manual operation also includes rapid traverse in reference position return.
- 2 Once rapid traverse has been selected, this signal remains "1", including during a stop, until another feedrate has been selected and movement has been started.

Cutting feed signal CUT <F002#6>

[Classification] Output signal

[Function] Signals that cutting feed is being performed by automatic operation.

[Output condition] This signal is set to 1 in the following case:

- When cutting feed is being performed by automatic operation (cutting feed for linear interpolation, circular interpolation, helical interpolation, thread cutting, skip cutting, or cutting in canned cycle)

CAUTION

This signal is not set to "1" in the feed hold state.

NOTE

This signal is set to "1" even when the feedrate override is 0%, and even during interlock.

Signal address

	#7	#6	#5	#4	#3	#2	#1	#0
F002		CUT					RPDO	

2.9 VRDY OFF ALARM IGNORE SIGNAL

General

The German VDE safety standard requires that the motor be deactivated when the safety guard is opened. By using the VRDY OFF Alarm Ignore signal, however, the CNC can be restarted without resetting, even if the safety guard has been opened.

Signal

All-Axis VRDY OFF Alarm Ignore Signal IGNVRY<G066#0>

[Classification] Input signal

[Function] Disables the detection of servo alarm No. 401, VRDY OFF, for all axes.

[Operation] When this signal is set to logical 1, the control unit operates as follows:

- The control unit does not issue servo alarm No. 401, VRDY OFF, even when the servo amplifier ready signal goes off. The control unit, however, sets servo ready signal SA to 0. The SA signal can remain set to 1, depending on the setting of SAK, bit 6 of parameter No. 1804.

Each-Axis VRDY OFF Alarm Ignore Signal IGVRY1 – IGVRY8 <G192>

[Classification] Input signal

[Function] Disables the detection of servo alarm No. 401, VRDY OFF, for the corresponding axis. These signals correspond to the controlled axes. The suffixed number of each signal corresponds to the number of the controlled axis.

[Operation] When this signal is set to logical 1, the control unit operates as follows:

- The control unit does not issue servo alarm No. 401, VRDY OFF, even when the servo amplifier ready signal for the corresponding axis goes off. The servo ready signal SA, however, is set to 0. The SA signal, however, can remain set to 1 depending on the setting of SAK, bit 6 of parameter No. 1804.

Signal address

	#7	#6	#5	#4	#3	#2	#1	#0
G066								IGNVRY
G192	IGVRY8	IGVRY7	IGVRY6	IGVRY5	IGVRY4	IGVRY3	IGVRY2	IGVRY1

Parameter

	#7	#6	#5	#4	#3	#2	#1	#0
1804		SAK						

[Data type] Bit

SAK When the VRDY OFF Alarm Ignore signal IGNVRY is 1, or when any of the VRDY OFF Alarm Ignore signals IGVRY1 to IGVRY8 are 1:

0 : Servo ready signal SA is set to 0.

1 : Servo ready signal SA remains set to 1.

Alarm and Message

Number	Message	Description
401	SERVO ALARM: n-TH AXIS VRDY OFF	The n-th axis (axis 1-8) servo amplifier READY signal (DRDY) went off.

Caution**CAUTION**

- 1 When the control enters NOT READY status due to emergency stop or a servo alarm and then the control is reset, reset processing is not terminated until the VRDY OFF alarm ignore signal is set to 0.
- 2 When the VRDY OFF alarm ignore signal is set to 1 and the servo amplifier ready signal is set to off, the motor is freed from the drive, but follow up is not performed. To perform follow up, set the servo off signal to 1.

Note**NOTE**

While the VRDY OFF alarm ignore signal is set to 1, and a servo alarm other than alarm No. 401 occurs, the control unit detects the alarm.

2.10 ABNORMAL LOAD DETECTION

General

Machine collision, defective, and damaged cutters cause a large load torque on the servo and spindle motors, compared with normal rapid traverse or cutting feed. This function detects the load torque on the motors and sends this value as an estimated load torque to the PMC. If the detected load torque value is abnormally great compared with the value specified in the parameter, the function stops the servo motor as early as possible or reverses the motor by an appropriate value specified in a parameter, in order to minimize possible damage to the machine. (The function to reverse motors is effective only for servo motors.)

The abnormal load detection function is further divided as follows:

(1) Estimated load torque output function

The CNC is always calculating the estimated load torque for the motor (excluding acceleration/deceleration torque). The estimated load torque output function enables the PMC to read the calculated torque using the window function.

(2) Abnormal load detection alarm function

This function stops motors or reverses them by an amount specified in a parameter, causing the CNC to output an alarm, whenever the load torque obtained by the estimated load torque output function is greater than the value specified in a parameter. (The function to reverse motors is effective only for servo motors.)

Abnormal load detection can also be disabled only for specific axes by using bit 5 (ABDSW) of parameter No. 2215 for the abnormal load detection function and abnormal load detection ignore signals IUDD1 to IUDD8 <G0125>. (This function is effective only for servo motors.)

● **Parameter setting**

The following flowcharts explain how to specify parameters for the abnormal load detection function.

(1) Servo axis

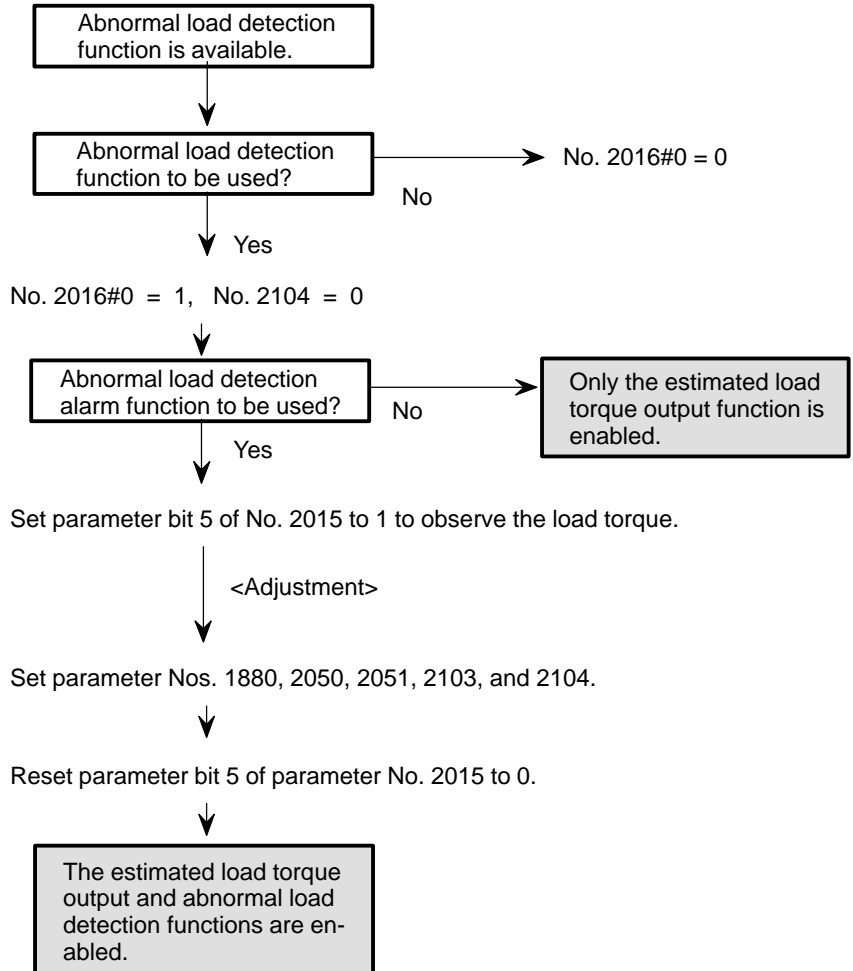

(2) Spindle

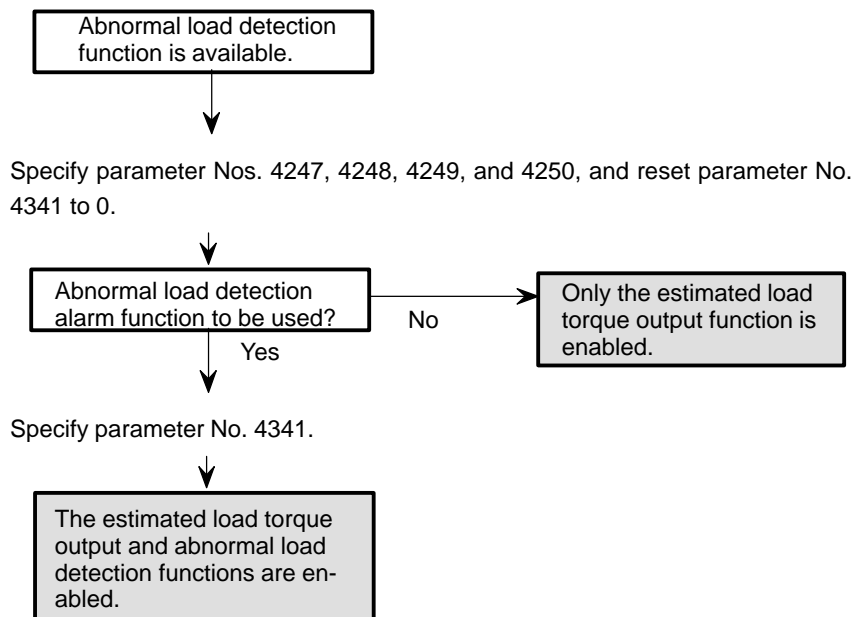

Signal

Servo axis abnormal load detected signal ABTQSV <F090#0>

[Classification] Output signal

[Function] Informs the PMC that an abnormal load was detected on a servo axis.

[Output condition] This signal becomes “1” if:

- An abnormal load is detected for a servo axis, Cs axis, spindle positioning axis, or spindle axis during rigid tapping.

First-spindle abnormal load detected signal ABTSP1 <F090#1>

[Classification] Output signal

[Function] Informs the PMC that an abnormal load was detected on the first spindle axis.

[Output condition] This signal becomes “1” if:

- An abnormal load is detected for the first spindle under speed control.

Second-spindle abnormal load detected signal ABTSP2 <F090#2>

[Classification] Output signal

[Function] Informs the PMC that an abnormal load was detected on the second spindle axis.

[Output condition] This signal becomes “1” if:

- An abnormal load is detected for the second spindle under speed control.

The following list summarizes the alarms and signals output by each function.

	Signal output		Alarm	
	ABTQSV	ABTSP1/ ABTSP2	409	754/764
Servo axis	○	—	○	—
Cs contour control	○	—	○	—
Spindle positioning axis	○	—	○	—
Rigid tapping	○	—	—	○
Spindle axis for speed control	—	○	—	○

Abnormal load detection ignore signal IUDD1 to IUDD8 <G0125>

[Classification] Input signal

[Function] These signals disable the abnormal load detection function for corresponding axes. These signals correspond to the controlled axes. The suffixed number of each signal corresponds to the number of a controlled axis.

[Output condition] When the signal is set to 1, abnormal load detection is not performed for the corresponding axis.
When the signal is used, bit 5 (ABDSW) of parameter No. 2215 for the abnormal load detection function must be set to 1.

Signal address

	#7	#6	#5	#4	#3	#2	#1	#0
F0090						ABTSP2	ABTSP1	ABTQSV
G0125	IUDD8	IUDD7	IUDD6	IUDD5	IUDD4	IUDD3	IUDD2	IUDD1

Parameter

(1) Parameter common to servo axes and spindles

1880	Timer for abnormal load detection alarm
------	---

[Data type] Word

[Unit of data] msec

[Valid data range] 0 to 32767
(If 0 is set, 200 ms is assumed.)

This parameter specifies the interval between the detection of an abnormal load and the issuance of a servo alarm. When the set value is not a multiple of eight, it is rounded up to the nearest multiple of eight.

[Example] When 30 is set, the system assumes 32 ms.

(2) Servo axis parameters

	#7	#6	#5	#4	#3	#2	#1	#0
2015			TDOUT					

[Data type] Bit axis

TDOUT Select output to the check board (for each axis)

0 : Output the torque command to the check board.

1 : Output the estimated load torque to the check board.

	#7	#6	#5	#4	#3	#2	#1	#0
2016								ABNTDT

[Data type] Bit axis

ABNTDT Output of the estimated load torque (for each axis)

0 : Disabled

1 : Enabled

This parameter must be specified when using the estimated load torque output function or the abnormal load detection alarm function.

2050	Velocity control observer
------	---------------------------

[Data type] Word axis

[Valid data range] 0 to 32767

[Setting value] 3559

When using the velocity loop observer (by setting bit 2 of parameter No. 2003 to 1), set 956 in this parameter.

2051	Velocity control observer
------	---------------------------

[Data type] Word axis

[Valid data range] 0 to 32767

[Setting value] 3329

When using the velocity loop observer (by setting bit 2 of parameter No. 2003 to 1), set 510 in this parameter.

2103	Retraction distance upon the detection of an abnormal load
------	--

[Data type] Word axis

[Unit of data] Detection unit

[Valid data range] 0 to 32767

This parameter specifies the distance by which the tool is to be retracted, by reversing the motor, if an abnormal load is detected. When the motor is rotating at low speed, however, the tool may be retracted too far. To prevent this, the motor is stopped, instead of being reversed, while the specified feedrate is less than the value listed in the table below.

When this parameter is set to value A, the detection of an abnormal load causes the tool to be retracted in the reverse direction by the distance A, then stopped, if the specified feedrate is equal to or greater than the value listed below.

Detection unit	Feedrate
1 μ	A / 8 mm/ min
0.1 μ	A / 80 mm/ min

When this parameter is set to 0, the motor stops immediately upon the detection of abnormal load.

2104	Threshold for abnormal load detection alarm
------	---

[Data type] Word axis

[Unit of data] Torque command unit (Refer to the digital servo operator's manual for details.)

[Valid data range] 0 to 7282

(The maximum motor torque is 7282, regardless of the motor type.)

This parameter specifies the threshold load torque at which an abnormal load detection alarm is issued.

Monitor the load torque by setting bit 5 of parameter No. 2015 to 1 then, for this parameter (No. 2104), set a value larger than the maximum monitored torque. An output of 4.4 V is equivalent to 7282 in the units of this parameter.

	#7	#6	#5	#4	#3	#2	#1	#0
2215			ABDSW					

[Data type] Bit axis

ABDSW The abnormal load detection function for a specified axis:

0 : Cannot be disabled.

1 : Can be disabled.

(3) Spindle parameters

	#7	#6	#5	#4	#3	#2	#1	#0
4015							SPLDMT	

[Data type] Bit axis

SPLDMT Spindle load torque monitor function

0 : The spindle load torque monitor function is disabled.

1 : The spindle load torque monitor function is enabled.

4247	Magnetic flux compensation time constant for spindle load torque monitor
------	--

[Data type] Word axis

[Unit of data] 1 msec

[Valid data range] 0 to 8192

[Standard setting] Depends of the motor model.

This parameter is used to compensate the delay in the generation of magnetic flux in the spindle motor relative to the specified value. When 0 is set, it is assumed that the generation of magnetic flux is not delayed.

4248	Spindle load torque monitor constant
------	--------------------------------------

[Data type] Word axis

[Valid data range] 0 to 32767

[Standard setting] Depends of the motor model.

This constant is determined by the maximum output torque and inertia of the motor. It is used for observer processing.

4249	Observer gain 1 for spindle load torque monitor
------	---

[Data type] Word axis

[Valid data range] 0 to 32767

[Standard setting] 500

4250	Observer gain 2 for spindle load torque monitor
------	---

[Data type] Word axis

[Valid data range] 0 to 32767

[Standard setting] 500

4341	Threshold for abnormal load detection alarm
------	---

[Data type] Word axis

[Unit of data] 0.01 %

[Valid data range] 0 to 10000

This parameter specifies the threshold load torque at which an abnormal load detection alarm is issued for the spindle. Set a percentage (in units of 0.01 %) for the maximum output torque of the motor. When 0 is set, no abnormal load detection alarm is issued for the spindle.

Alarm and message

(1) Servo axis

Number	Message	Description
409	Servo alarm: Abnormal load detected on axis n	An abnormal load was detected on a servo motor, or on a spindle motor during Cs mode. To release the alarm, use RESET.

(2) Spindle

Number	Message	Description
754	Abnormal load detected on the first spindle	An abnormal load was detected on the first spindle motor. To release the alarm, use RESET.
764	Abnormal load detected on the second spindle	An abnormal load was detected on the second spindle motor. To release the alarm, use RESET.

PMC window function

- **Reading the load torque data**

The load torque data can be read at the PMC using its window function.
(1) Servo axis

[Input data structure]

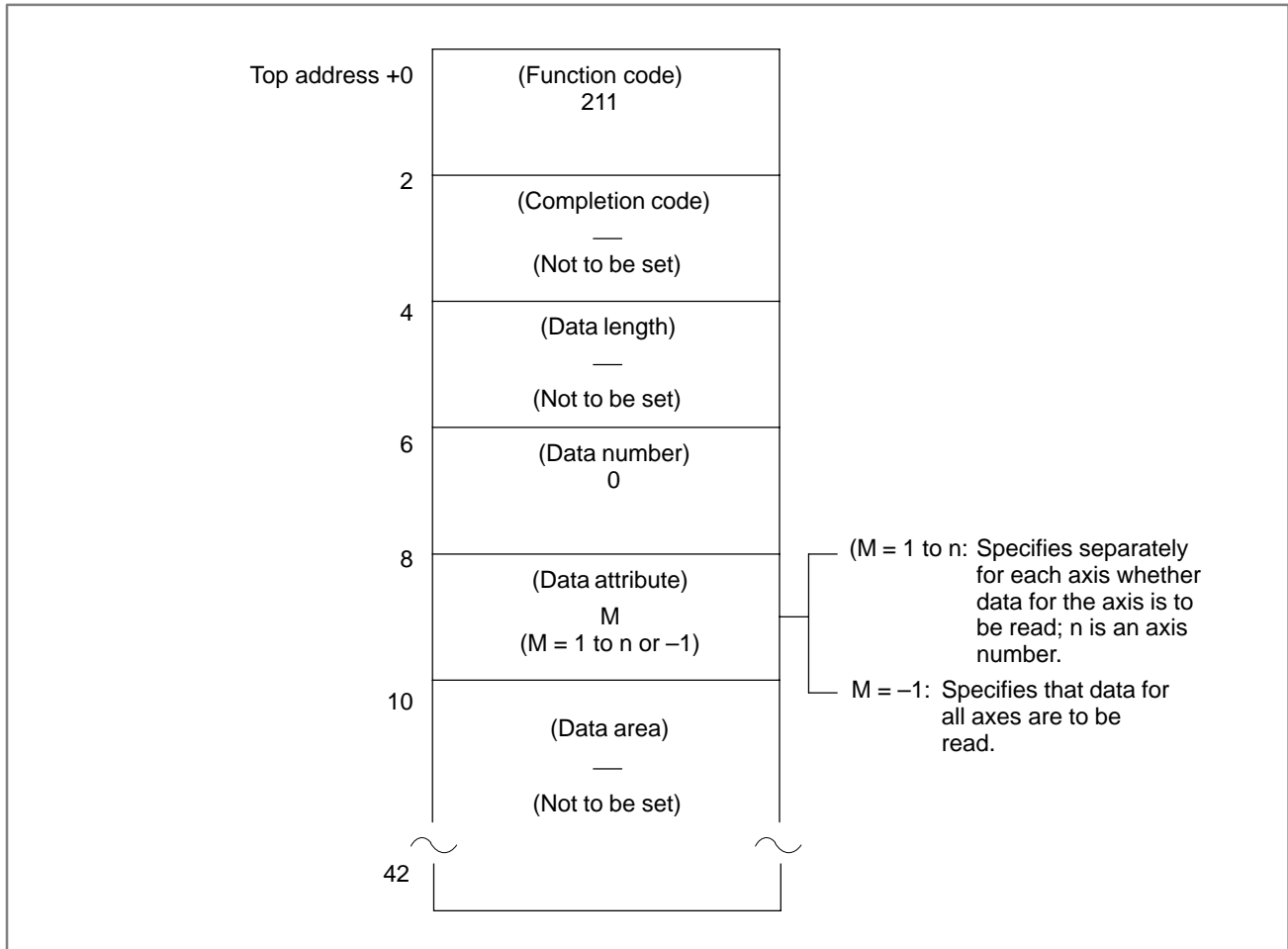

[Completion code]

- 0: The load torque data was read normally.
- 4: Invalid data was specified as a data attribute, that is a value other than -1 or 1 to n (number of axes) was specified. Alternatively, a value greater than the number of controllable axes was specified.

[Output data structure]

Top address + 0	(Function code) 211	
2	(Completion code) ? (Refer to the above description about the completion code.)	
4	(Data length) L (L = 2*n, where n is the num- ber of specified axes)	
6	(Data number) 0	
8	(Data attribute) M (M: Data at input)	Description of value
10	Load torque for the specified axis (2 bytes)	Signed binary format (negative val- ue in two's complement)

Or if there are four controllable axes

		Description of value
10	Load torque for the first axis (2 bytes)	Signed binary format (negative val- ue in two's complement)
12	Load torque for the second axis (2 bytes)	
14	Load torque for the third axis (2 bytes)	
16	Load torque for the fourth axis (2 bytes)	

(2) Spindle

[Input data structure]

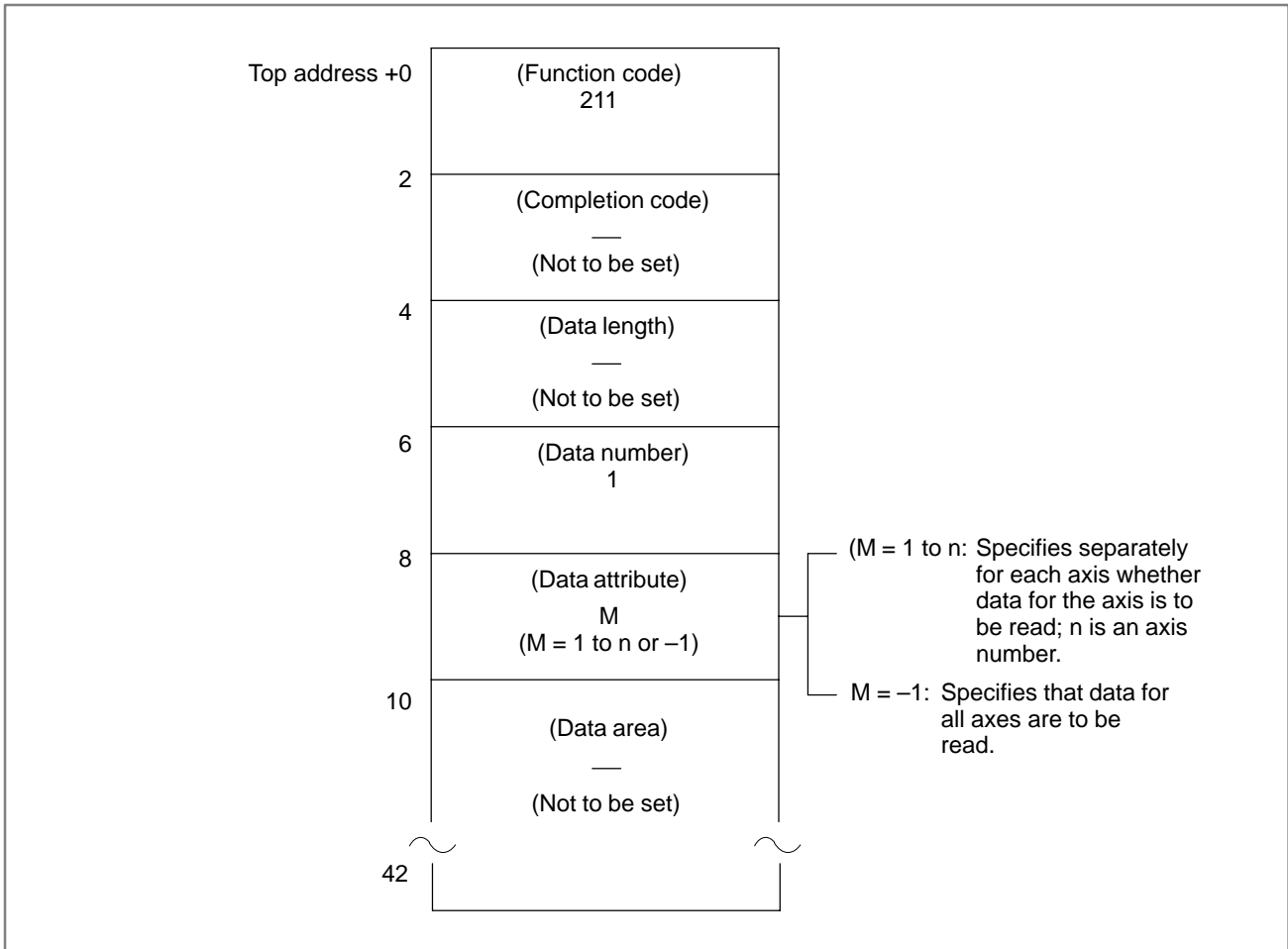

[Completion code]

- 0: The load torque data was read normally.
- 4: Invalid data was specified as a data attribute, that is a value other than -1 or 1 to n (number of axes) was specified. Alternatively, a value greater than controllable axes was specified.

[Output data structure]

Top address + 0	(Function code) 211	
2	(Completion code) ? (Refer to the above description about the completion code.)	
4	(Data length) L (L = 2*n, where n is the num- ber of specified axes)	
6	(Data number) 1	
8	(Data attribute) M (M: Data at input)	Description of value
10	Load torque for the specified axis (2 bytes)	Signed binary format (negative val- ue in two's complement)

Or if there are two controllable axes

		Description of value
10	Load torque for the first axis (2 bytes)	Signed binary format (negative val- ue in two's complement)
12	Load torque for the second axis (2 bytes)	

2.11 SERVO/SPINDLE MOTOR SPEED DETECTION

General

The servo axis and spindle motor speeds are monitored. If the speed of an axis exceeds a preset maximum (specified by parameter setting), the corresponding signal is output to a Y address (specified by parameter setting) of the PMC.

(1) Setting a Y address for signal output

In parameter No. 1891, set a Y byte address to which signals are to be output. (See Signal Address section for format)

(2) Setting a maximum speed

Set the maximum speed for each servo-motor-controlled axis in parameter No. 1890.

Set the maximum speed for the axis controlled by the first serial spindle motor in S1 of parameter No. 4345.

Set the maximum speed for the axis controlled by the second serial spindle motor in S2 of parameter No. 4345.

When 0 is specified as the maximum speed for an axis, the speed of that axis is not monitored.

(3) Signal input

Set the motor speed detection function enable signal MSDFON to 1. When the power is turned on, the CNC checks the status of this signal. If the signal is 1, the CNC enables the motor speed detection function. When MSDFON is 1, and a motor speed exceeds the preset maximum, the corresponding bit of the set Y address is set to 1.

The following diagram illustrates the signal output timing.

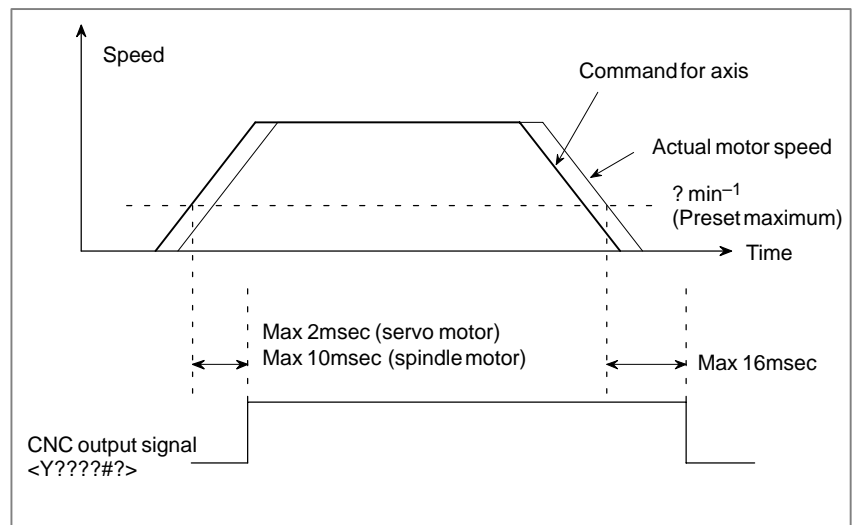

NOTE

The status of each signal is updated every 8 msec. (Fluctuations in real speed of less than 8 msec duration cannot be detected.)

Signal

Motor speed detection function enable signal MSDFON <G016#0>

[Classification] Input signal

[Function] Enables the motor speed detection function.

[Operation] When this signal is 1, the motor speed detection function is enabled.

The servo/spindle motor speed detection function allows the CNC to output a detected result to the Y addresses directly. Normally, only the PMC can write to the Y addresses. When this function is used, however, the CNC can also write to the Y addresses. Therefore, care must be taken not to write to the Y addresses from both the CNC and PMC.

When this signal is 1, the CNC enables this function, assuming that the PMC ladder does not use the address set in parameter No. 1891 and the next address (the setting + 1).

When the signal is 0, the CNC disables this function, assuming that the PMC ladder is using these Y addresses.

When using the servo/spindle motor speed detection function, remember to add the processing for setting the motor speed detection function enable signal to 1 to the PMC ladder. When doing so, care must be taken to ensure that the PMC ladder does not use the address set in parameter No. 1891 and address (the setting + 1), as the Y address.

CAUTION

- 1 Immediately after the PMC ladder starts operating, set the signal to 1.
- 2 When this signal is set to 0 after the CNC starts, the servo/spindle motor speed detection function is not disabled.

Servo motor speed detection signals DSV1 to DSV8 <Y(n + 0)>

(n is the value set in parameter No. 1891.)

[Classification] Output signal

[Function] Report the motor speed status of each of the axes controlled by servo motors.

[Operation] Each signal is set to 1 when:

- The servo motor speed exceeds the maximum speed set in parameter No. 1890.

Each signal is set to 0 when:

- The servo motor speed does not exceed the maximum speed set in parameter No. 1890.

**Spindle motor speed
detection signals DSP1,
DSP2, DSP3 <Y(n + 1)#0
to #2>**

(n is the value set in parameter No. 1891.)

[Classification] Output signal

[Function] Report the motor speed status of each of the axes controlled by spindle motors.

[Operation] Each signal is set to 1 when:

- The spindle motor speed exceeds the maximum speed set in parameter No. 4345.

Each signal is set to 0 when:

- The spindle motor speed does not exceed the maximum speed set in parameter No. 4345.

CAUTION

- 1 When two-path control is applied, the detection results for the axes in path 2 are output to the addresses set with parameter No. 1891 for path 2, in the same way as described above. Set the parameter for each path so that the difference between the setting made for path 1 and that made for path 2 is at least +2. This prevents the outputs from the paths from overlapping.
- 2 Some of the servo motor speed detection signals DSV1 to DSV8 and spindle motor speed detection signals DSP1, DSP2, and DSP3 may not function depending on the axis configuration. Even when some signals do not function, the addresses Y(n + 0) #7 to #0 and Y(n + 1) #1 and #0 must not be used by the PMC ladder.
- 3 When this function is used, Y(n + 1) #7 to #3 are reserved. These bits must not be used by the PMC ladder.
- 4 A spindle motor may be used for controlling a positioning axis, or a servo motor may be used for a spindle. This function performs motor-related detection.

Example: When Cs contour axis control is performed (the spindle and C-axis are controlled by the first serial spindle motor), the fourth axis is used as the C-axis.

In this case, if the preset maximum speed is exceeded, the following occurs regardless of whether spindle control or C-axis control is being performed:

DSP1 <Y(n + 1) #0, where n = setting in parameter No. 1891> is turned on.

DSV4 <Y(n + 0) #3, where n = setting in parameter No. 1891> is not affected.

Signal address

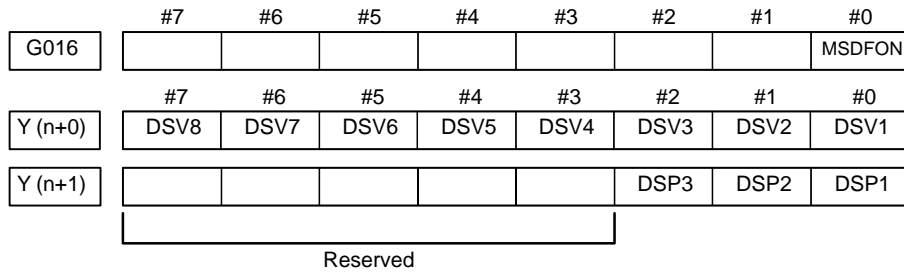

Parameter

1890	Servo motor speed for detection
------	---------------------------------

NOTE

After this parameter has been set, the power must be turned off before operation is continued.

[Data type] Word

[Unit of data] min⁻¹

[Valid data range] 0 to 8000

The servo motor speed of each axis is monitored and compared with the value in this parameter. A motor speed detection signal is then output indicating whether the speed of each axis exceeds the value set in this parameter. (The location of the Y address is specified in parameter No. 1891)

NOTE

The motor speed detection signals are inactive whenever the servo/spindle motor speed detection function is not used or whenever 0 is set in this parameter.

1891	Initial value of the Y address where motor speed detection signals are output
------	---

NOTE

After this parameter has been set, the power must be turned off before operation is continued.

[Data type] Word

[Valid data range] 0 to 126

This parameter specifies the Y address where motor speed detection signals are output.

The spindle motor speeds and servo motor speed of each axis are monitored and motor speed detection signals are output to the Y address specified in this parameter and (Y address +1) to indicate whether speeds exceed the values set in the parameters.

WARNING

- 1 Be sure to specify a Y address that is not used with a PMC sequence program (ladder).
- 2 When controlling two path lathe, ensure that the same value is not set for path 1 and path 2. (Set a separate address for path 1 and path 2 and take care they do not overlap.)

NOTE

The motor speed detection signals are inactivate whenever the servo/spindle motor speed detection function is not used, whenever the value 0 or a value beyond the allowable data range is specified in this parameter, or an input/output address specified within the allowable data range represents an address where no I/O device is mounted.

4345

Serial spindle motor detection speed

[Data type] Word

[Unit of data] min^{-1}

[Valid data range] 0 to 32767

S1 : for First spindle / S2 : for Second spindle / S3 : for Third spindle

This parameter sets the serial spindle motor speed at which the motor speed detection signal is output. The speeds of the serial spindle motors for the first, second, and third spindles are monitored, and the motor speed detection signal, indicating whether the speed of each spindle exceeds the value set in this parameter, is output to the Y address specified with parameter No. 1891.

WARNING

For this parameter, set a motor speed rather than a spindle speed.

NOTE

The motor speed detection signals are inactivate whenever the servo/spindle motor speed detection function is not used, or whenever 0 is set for this parameter.

Note**NOTE**

- 1 Spindle motor speed detection is enabled only for serial spindles.
- 2 The relationship between servo motor speed detection signals DSV1 to DSV8 and the servo motors depends on the servo axis number (servo connector number) set in parameter No. 1023.
- 3 In the case of a two-path control, commands can be switched between the paths by using composite control (T series) or S command selection.
Even when such command switching is performed, the relationship between detection signals DSV1 to DSV8, DSP1, DSP2, and DSP3 and the corresponding motors remains fixed. (The relationship is determined as described in Note 2 above.)

3

MANUAL OPERATION



3.1 JOG FEED/ INCREMENTAL FEED

General

- **Jog feed**

In jog mode, setting a feed axis and direction selection bit to “1” on the machine operator’s panel moves the tool along the selected axis in the selected direction.

Manual operation is allowed one axis at a time. 3 axes can be selected at a time by setting parameter JAX (No.1002#0).

- **Incremental feed**

In incremental feed mode, setting a feed axis and direction selection bit to “1” on the machine operator’s panel moves the tool one step along the selected axis in the selected direction. The minimum distance the tool is moved, is the least input increment. The step can be 10, 100, or 1000 times the least input increment.

The jog feedrate is specified in parameter (No.1423)

The jog feedrate can be adjusted with the jog feedrate override dial.

With rapid traverse selected, the tool can be moved at the rapid traverse rate regardless of the jog feedrate override signal.

Signal

The following signals determine that way the jog feed or incremental feed is executed.

Selection	Jog feed	Incremental feed
Mode selection	MD1, MD2, MD4, MJ	MD1, MD2, MD4, MINC
Selection of the axis to move	+J1, -J1, +J2, -J2, +J3, -J3, ...	
Selection of the direction to move the axis		
Selection of the move amount		MP1, MP2
Selection of feedrate	*JV0 – *JV15, RT, ROV1, ROV2	

The only difference between jog feed and incremental feed is the method of selecting the feed distance. In jog feed, the tool continues to be fed while the following signals selecting the feed axis and direction are “1”: +J1, -J1, +J2, -J2, +J3, -J3, etc. In incremental feed, the tool is fed by one step.

The distance of the step is selected by the manual handle feed move distance select signals MP1 and MP2.

For the signals selecting the mode, see Section 2.6, “Mode Selection Signals.” For the manual handle feed selection signals, MP1 and MP2 select the move amount, see 3.2 “Manual handle feed.” For rapid traverse override signals ROV1 and ROV2, see Section 7.1.7.1, (Feedrate Override Signals).

Other signals are described below.

Feed Axis and Direction Selection Signal

+J1 – +J8<G100>

-J1 – -J8<G102>

[Classification] Input signal

[Function] Selects a desired feed axis and direction in jog feed or incremental feed. The sign (+ or -) in the signal name indicates the feed direction. The number following J indicates the number of the control axis.

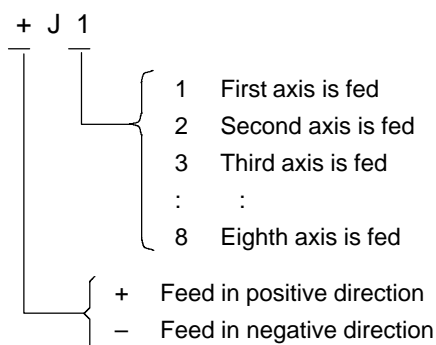

[Operation] When the jog bit is “1”, the control unit operates as described below.

- When jog feed or incremental feed is allowed, the control unit moves the specified axis in the specified direction.
- In jog feed, the control unit continues to feed the axis while the bit is “1”.

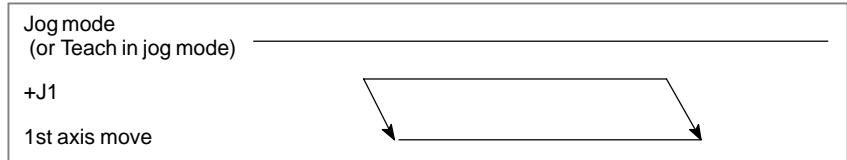

- In incremental feed, the control unit feeds the requested axis by the step distance which is specified by the manual handle feed move distance selection signals MP1, MP2, then the axis stops. Even if the signal is set to “0” while the axis is being fed, the control unit does not stop moving.
To feed the axis again, set the signal to “0”, then to “1” again.

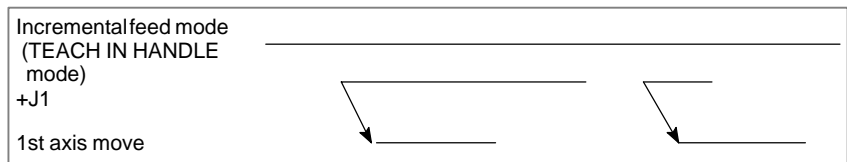

NOTE

- 1 If both the positive direction and negative direction signals of the same axis are simultaneously set to “1”, neither the positive direction nor the negative direction is selected. The control unit assumes that both these signals are set to “0”.
- 2 If the feed axis and direction selection signals are set to “1” before the jog feed mode or incremental feed mode is selected, these signals are invalidated. After the jog feed mode or incremental feed mode is selected, set these signal to “0”, then set them to “1” again.

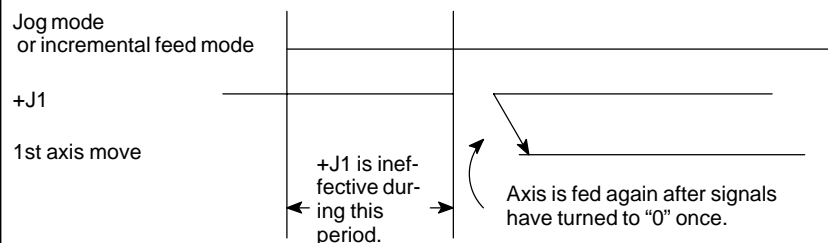

- 3 If the control unit is reset while the feed axis and direction selection signals are set to “1” or if a feed axis and direction signal turns to “1” while the control unit is in the reset state, the signal will be ignored even after releasing reset. After the reset state is released, set these signals to “0”, then set them to “1” again.

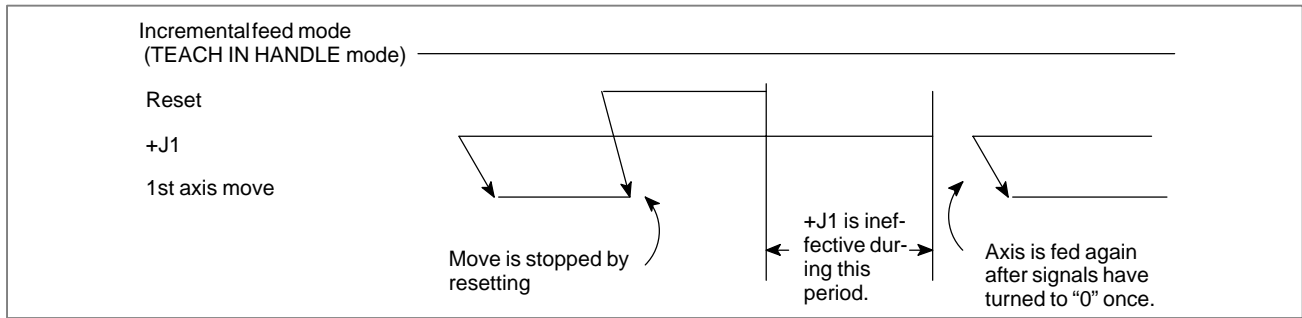

Manual Feedrate Override Signal

*JV0 – *JV15

<G010, G011> [Classification] Input signal

[Function] Selects a feedrate in jog feed or incremental feed. These signals are in sixteen bit binary code, which corresponds to the override values as follows:

$$\text{Override value (\%)} = 0.01\% \times \sum_{i=0}^{15} |2^i \times V_i|$$

where

$V_i = 0$ when the *JV i signal is "1"

$V_i = 1$ when the *JV i signal is "0"

The override value is assumed to be zero when all of the signals, (*JV0 to *JV15) are set to “1” or “0”. When this occurs, the feed is stopped. The override value can be specified in the range of 0% to 655.34% in units of 0.01%. Same examples are listed below.

*JV0 – *JV15				Override value (%)
12	8	4	0	
1 1 1 1	1 1 1 1	1 1 1 1	1 1 1 1	0
1 1 1 1	1 1 1 1	1 1 1 1	1 1 1 0	0.01
1 1 1 1	1 1 1 1	1 1 1 1	0 1 0 1	0.10
1 1 1 1	1 1 1 1	1 0 0 1	1 0 1 1	1.00
1 1 1 1	1 1 1 1	0 0 1 1	0 1 1 1	2.00
1 1 1 1	1 1 1 0	1 1 0 1	0 0 1 1	3.00
1 1 1 1	1 1 1 0	0 1 1 0	1 1 1 1	4.00
1 1 1 1	1 1 1 0	0 0 0 0	1 0 1 1	5.00
1 1 1 1	1 1 0 0	0 0 0 1	0 1 1 1	10.00
1 1 1 1	1 0 1 0	0 0 1 0	0 0 1 1	15.00
1 1 1 1	1 0 0 0	0 0 1 0	1 1 1 1	20.00
1 1 1 1	0 1 1 0	0 0 1 1	1 0 1 1	25.00
1 1 1 1	0 1 0 0	0 1 0 0	0 1 1 1	30.00
1 1 1 1	0 0 1 0	0 1 0 1	0 0 1 1	35.00
1 1 1 1	0 0 0 0	0 1 0 1	1 1 1 1	40.00
1 1 1 0	1 1 1 0	0 1 1 0	1 0 1 1	45.00
1 1 1 0	1 1 0 0	0 1 1 1	0 1 1 1	50.00
1 1 1 0	1 0 0 0	1 0 0 0	1 1 1 1	60.00
1 1 1 0	0 1 0 0	1 0 1 0	0 1 1 1	70.00
1 1 1 0	0 0 0 0	1 0 1 1	1 1 1 1	80.00
1 1 0 1	1 1 0 0	1 1 0 1	0 1 1 1	90.00
1 1 0 1	1 0 0 0	1 1 1 0	1 1 1 1	100.00
1 1 0 0	0 1 0 1	0 1 1 0	0 1 1 1	150.00
1 0 1 1	0 0 0 1	1 1 0 1	1 1 1 1	200.00
1 0 0 1	1 1 1 0	0 1 0 1	0 1 1 1	250.00
1 0 0 0	1 0 1 0	1 1 0 0	1 1 1 1	300.00
0 1 1 0	0 0 1 1	1 0 1 1	1 1 1 1	400.00
0 0 1 1	1 1 0 0	1 0 1 0	1 1 1 1	500.00
0 0 0 1	0 1 0 1	1 0 0 1	1 1 1 1	600.00
0 0 0 0	0 0 0 0	0 0 0 0	0 0 0 1	655.34
0 0 0 0	0 0 0 0	0 0 0 0	0 0 0 0	0

The value is calculated as follows.

1. In case that the override is 2%,
 - (1) Multiply override value by 100 to convert 0.01% unit. 200
 - (2) Convert to binary data. 0000 0000 1100 1000
 - (3) Do logical NOT of binary data. 1111 1111 0011 0111
2. In case that the input signal is "1110 1110 1110 1110",
 - (1) Do logical NOT of binary data. 0001 0001 0001 0001
 - (2) Convert to decimal data. 4369
 - (3) Divide override value by 100 to convert 1% unit. 43.69%

[Operation] If rapid traverse selection signal RT is “0” during jog feed or incremental feed, the manual feedrate specified by parameter (No. 1423) is overridden by the value specified by the JVi signal.

NOTE

The JVi signals also serve as the override signals during dry run in automatic operation mode.

Manual rapid traverse selection signal

RT<G019#7> [Classification] Input signal

[Function] Selects a rapid traverse rate for jog feed or incremental feed.

[Operation] When the signal turns to “1”, the control unit operates as described below:

- The control unit executes the jog feed or incremental feed at a rapid traverse rate. The rapid traverse override is validated.
- When the signal is switched from “1” to “0” or vice versa during jog feed or incremental feed, the feedrate is decelerated until it reaches zero, then increased to the specified value. During acceleration and deceleration, the feed axis and direction selection signal can be kept “1”.

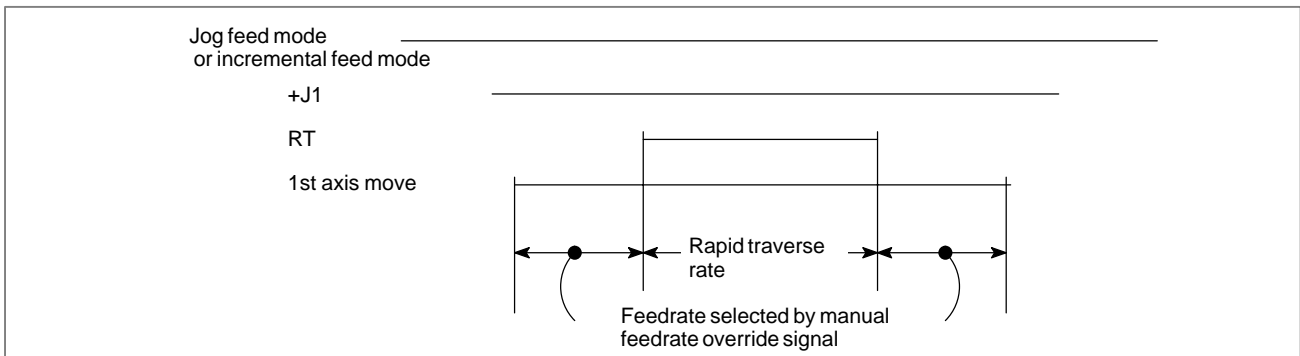

WARNING

After the power is turned on, the stroke limit function does not work until the reference position return is completed. During this period, the control unit ignores the RT signal, if it is set to “1”, and keeps moving the tool at a feedrate selected by the manual feedrate override signal. The parameter RPD (No. 1401#0) can be set so the rapid traverse is validated before the reference position return is completed.

Signal address

	#7	#6	#5	#4	#3	#2	#1	#0
G010	*JV7	*JV6	*JV5	*JV4	*JV3	*JV2	*JV1	*JV0
G011	*JV15	*JV14	*JV13	*JV12	*JV11	*JV10	*JV9	*JV8
G019	RT							
G100	+J8	+J7	+J6	+J5	+J4	+J3	+J2	+J1
G102	-J8	-J7	-J6	-J5	-J4	-J3	-J2	-J1

Parameter

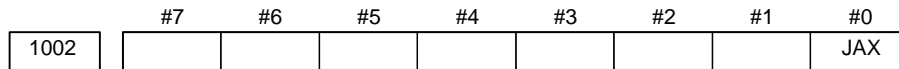

[Data type] Bit

JAX Number of axes controlled simultaneously in jog feed, manual rapid traverse and manual reference position return

- 0 : 1 axis
- 1 : 3 axes

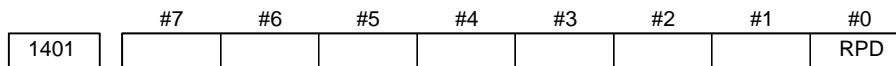

[Data type] Bit

RPD Manual rapid traverse during the period from power-on time to the completion of the reference position return.

- 0 : Disabled (Jog feed is performed.)
- 1 : Enabled

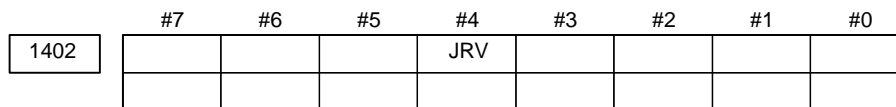

[Data type] Bit

JRV Manual continuous feed (jog feed)

- 0 : Jog feed is performed at feed per minute.
- 1 : Jog feed is performed at feed per rotation.

NOTE

Specify a feedrate in parameter No. 1423.

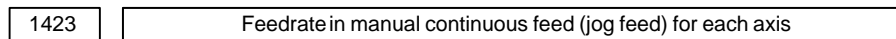

[Data type] Word axis

(1) In M series, or in T series when JRV, bit 4 of parameter No. 1402, is set to 0 (feed per minute), specify a jog feedrate at feed per minute with an override of 100%.

[Unit of data]	Increment system	Unit of data	Valid data range
[Valid data range]	Millimeter machine	1 mm/min	6 – 32767
	Inch machine	0.1 inch/min	
	Rotation axis	1 deg/min	

(2) When JRV, bit 4 of parameter No. 1402, is set to 1 (feed per revolution) in T series, specify a jog feedrate (feed per revolution) under an override of 100%.

[Unit of data]	Increment system	Unit of data	Valid data range
[Valid data range]	Millimeter machine	0.01 mm/rev	0 – 32767
	Inch machine	0.001 inch/rev	
	Rotation axis	0.01 deg/rev	

1424 Manual rapid traverse rate for each axis

[Data type] Two-word axis

[Unit of data]

[Valid data range]

Increment system	Unit of data	Valid data range	
		IS-A, IS-B	IS-C
Millimeter machine	1 mm/min	30 – 240000	30 – 100000
Inch machine	0.1 inch/min	30 – 96000	30 – 48000
Rotation axis	1 deg/min	30 – 240000	30 – 100000

Set the rate of manual rapid traverse when the rapid traverse override is 100% for each axis.

NOTE

If 0 is set, the rate set in parameter 1420 is assumed.

1610 #7 #6 #5 #4 #3 #2 #1 #0

			JGLx				
--	--	--	------	--	--	--	--

[Data type] Bit axis

JGLx Acceleration/deceleration in manual continuous feed (jog feed)

0: Exponential acceleration/deceleration is applied.

1: Linear acceleration/deceleration after interpolation or bell-shaped acceleration/deceleration after interpolation is applied (depending on which is used in cutting feed).

1624 Time constant of exponential acceleration/deceleration or bell-shaped acceleration/deceleration or linear acceleration/deceleration after interpolation, in jog feed for each axis.

[Data type] Word axis

[Unit of data] 1 msec

[Valid data range] 0 to 4000 (for exponential acceleration/deceleration)

0 to 512 (for linear acceleration/deceleration after interpolation or bell-shaped acceleration/deceleration)

Set the time constant used for exponential acceleration/deceleration, bell-shaped acceleration/deceleration or linear acceleration/deceleration after interpolation in jog feed for each axis.

1625 FL rate of exponential acceleration/deceleration in jog feed for each axis

[Data type] Word axis

[Unit of data]

[Valid data range]

Increment system	Unit of data	Valid data range	
		IS-A, IS-B	IS-C
Millimeter machine	1 mm/min	6 – 15000	6 – 12000
Inch machine	0.1 inch/min	6 – 6000	6 – 4800
Rotation axis	1 deg/min	6 – 15000	6 – 12000

Set the lower limit (FL rate) of exponential acceleration/deceleration in jog feed for each axis.

Warning**WARNING**

For incremental feeding along an axis under diameter programming, the tool moves in units of the diameter.

Note**NOTE**

- 1 Time constant and method of automatic acceleration/ deceleration for manual rapid traverse are the same as G00 in programmed command.
- 2 If a manual pulse generator is provided, the manual handle feed mode is enabled instead of incremental feed mode. However, using parameter JHD (bit 0 of parameter No. 7100) enables both manual handle and incremental feed in the manual handle feed mode.

Reference item

Series 16i/18i/160i/180i/ 160is/180is	OPERATOR'S MANUAL (For Machining Center) (B-63534EN)	III.3.2	JOG FEED
		III.3.3	INCREMENTAL FEED
	OPERATOR'S MANUAL (For Lathe) (B-63524EN)	III.3.2	JOG FEED
		III.3.3	INCREMENTAL FEED
Series 21i/210i/210is	OPERATOR'S MANUAL (For Machining Center) (B-63614EN)	III.3.2	JOG FEED
		III.3.3	INCREMENTAL FEED
	OPERATOR'S MANUAL (For Lathe) (B-63604EN)	III.3.2	JOG FEED
		III.3.3	INCREMENTAL FEED
Series 20i	OPERATOR'S MANUAL (For Manual Milling Machine) (B-64204EN)	III.3.2	JOG FEED
		III.3.3	INCREMENTAL FEED
	OPERATOR'S MANUAL (For Manual Lathes) (B-64194EN)	III.3.2	JOG FEED
		III.3.3	INCREMENTAL FEED

3.2 MANUAL HANDLE FEED

General

In manual handle feed mode, the tool can be incrementally moved by rotating the manual pulse generator. Select the axis along which the tool is to be moved with the handle feed axis selection signal.

The minimum distance the tool is moved when the manual pulse generator is rotated by one graduation is equal to the least input increment. Or the distance the tool is moved when the manual pulse generator is rotated by one graduation can be magnified by 10 times or by one of the two magnifications specified by parameters (No. 7113 and 7114).

The handle magnifications can be selected by the manual handle feed move distance selection signal.

The number of manual pulse generators available depends on the type of an option used as listed below.

(M series)

- Control with one manual handle: Up to one generator
- Control with two or three manual handles: Up to three generators

(T series)

- Control with one manual handle: Up to one generator
- Control with two manual handles: Up to two generators

Two-path control

Which manual pulse generator moves which axis of which path depends on the setting of manual handle feed axis select signals for each path. For each path, eight bits are reserved as manual handle feed axis select signals.

- **Availability of manual handle feed in Jog mode**

Parameter JHD (bit 0 of No. 7100) enables or disables the manual handle feed in the JOG mode.

When the parameter JHD (bit 0 of No. 7100) is set 1, both manual handle feed and incremental feed are enabled.

- **Availability of manual handle feed in TEACH IN JOG mode**

Parameter THD (bit 1 of No. 7100) enables or disables the manual handle feed generator in the TEACH IN JOG mode.

- **A command to the MPG exceeding rapid traverse rate**

Parameter (No. 7117) specifies as follows:

SET VALUE 0: The feedrate is clamped at the rapid traverse rate and generated pulses exceeding the rapid traverse rate are ignored. (The distance the tool is moved may not match the graduations on the manual pulse generator.)

Other than 0: The feedrate is clamped at the rapid traverse rate and generated pulses exceeding the rapid traverse rate are not ignored but accumulated in the CNC. (No longer rotating the handle does not immediately stop the tool. The tool is moved by the pulses accumulated in the CNC before it stops.)

- **Movement direction of an axis to the rotation of MPG**

Parameter HNGx (No. 7102#0) switches the direction in which the tool moves along an axis, corresponding to the direction in which the handle of the manual pulse generator is rotated.

Signal

Manual Handle Feed Axis Selection Signals

- **(M series)** **[Classification]** Input signal

HS1A – HS1D **[Function]** Selects the axis of manual handle feed. A set of four code signals, A, B, C, and D is provided for each manual pulse generator. (Up to three generators can be used.) (For two-path, these signals are provided for each manual pulse generator and each path.) The number in the signal name indicates the number of the manual pulse generator to be used.

<G018#0 – #3>

HS2A – HS2D

<G018#4 – #7>

HS3A – HS3D

<G019#0 – #3>

- **(T series)**

HS1A – HS1D

<G018#0 – #3>

HS2A – HS2D

<G018#4 – #7>

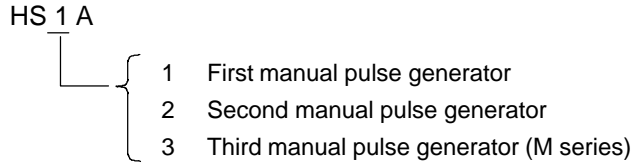

- **(Two-path control)**

HS1A#1 – HS1D#1

<G018#0 – #3>

HS2A#1 – HS2D#1

<G018#4 – #7>

HS3A#1–HA3D#1 (M series)

<G019#0–#3>

HS1A#2 – HS1D#2

<G1018#0 – #3>

HS2A#2 – HS2D#2

<G1018#4 – #7>

HS3A#3–HS3D#2 (M series)

<G1019#0–#3>

Code signals A, B, C, and D correspond to the feed axes as listed in the following table:

Manual handle feed axis selection				Feed axis
HSnD	HSnC	HSnB	HSnA	
0	0	0	0	No selection (None of axis is fed)
0	0	0	1	1st axis
0	0	1	0	2nd axis
0	0	1	1	3rd axis
0	1	0	0	4th axis
0	1	0	1	5th axis
0	1	1	0	6th axis
0	1	1	1	7th axis
1	0	0	0	8th axis

<Two-path control>

Manual handle feed axis selection				Feed axis
HSnD#1	HSnC#1	HSnB#1	HSnA#1	
0	0	0	0	No selection (no axis is used for path 1)
0	0	0	1	1st axis of path 1
0	0	1	0	2nd axis of path 1
0	0	1	1	3rd axis of path 1
0	1	0	0	4th axis of path 1
0	1	0	1	5th axis of path 1
0	1	1	0	6th axis of path 1
0	1	1	1	7th axis of path 1

Manual handle feed axis selection				Feed axis
HSnD#2	HSnC#2	HSnB#2	HSnA#2	
0	0	0	0	No selection (no axis is used for path 2)
0	0	0	1	1st axis of path 2
0	0	1	0	2nd axis of path 2
0	0	1	1	3rd axis of path 2
0	1	0	0	4th axis of path 2
0	1	0	1	5th axis of path 2
0	1	1	0	6th axis of path 2
0	1	1	1	7th axis of path 2

**Manual Handle Feed
Amount Selection Signal
MP1, MP2<G019#4, 5>
(Incremental Feed
Signal)**

[Classification] Input signal

[Function] This signal selects the distance traveled per pulse from the manual pulse generator during the manual handle feed or manual handle interrupt. It also selects the distance traveled per incremental feed step. The table below lists the signal-to-distance correspondence.

Travel distance select signal for manual handle feed		Distance traveled		
MP2	MP1	Manual handle feed	Manual handle interrupt	Incremental feed
0	0	Least input increment × 1	Least command increment × 1	Least input increment × 1
0	1	Least input increment × 10	Least command increment × 10	Least input increment × 10
1	0	Least input increment × m*1	Least command increment × m*1	Least input increment × 100
1	1	Least input increment × n*1	Least command increment × n*1	Least input increment × 1000

*1 Scale factors m and n are specified using parameter Nos. 7113 and 7114.

WARNING

- 1 Because the least input increment is used as the units for manual handle and incremental feed, the same value represents a different distance depending on whether the metric or inch input system is used.
- 2 For an axis under diameter programming, the tool moves by the diameter value.

NOTE

See Section 3.3, "Manual Handle Interrupt" for manual handle interrupts, and Section 3.1, "Jog Feed/Incremental Feed" for incremental feed.

● **Series 20i manual handle feed**

In the Series 20i, up to three (T series) or four (F series) manual handle pulse generators can be used. So, the following manual handle feed axis select signals are also valid for the Series 20i.

- HS3A to HS3D <G019#0 to #3> (T series)
- HS4A to HS4D <G020#0 to #3> (F series)

HS 1 A

- 1 Selects an axis for which feed is controlled using the first manual pulse generator.
- 2 Selects an axis for which feed is controlled using the second manual pulse generator.
- 3 Selects an axis for which feed is controlled using the third manual pulse generator.
- 4 Selects an axis for which feed is controlled using the fourth manual pulse generator (F series).

Setting bit 5 of parameter No. 7100 (MPX) enables each manual handle feed travel distance select signal to be used for an individual manual pulse generator.

Manual handle feed travel distance select signals

- MP21, MP22 <G087#0, #1>
- MP31, MP32 <G087#3, #4>
- MP41, MP42 <G087#6, #7>

The following table lists the relationships between the manual handle feed travel distance select signal that is effective for an individual manual pulse generator and the parameter number for setting a magnification.

State of bit 5 of parameter No. 7100 (MPX)	Manual pulse generator	Effective manual handle feed travel distance select signals	Parameter for setting a magnification	
			Mn	Nn
MPX=0	First to fourth pulse generators	MP1, MP2	No.7113	No.7114
MPX=1	First pulse generator	MP1, MP2	No.7113	No.7114
	Second pulse generator	MP21, MP22	No.7131	No.7132
	Third pulse generator	MP31, MP32	No.7133	No.7134
	Fourth pulse generator	MP41, MP42	No.7135	No.7136

The following table lists the relationships between each manual handle feed travel distance select signal and the travel distance specified by the signal.

Manual handle feed travel distance select signal		Travel distance		
MP2 MP22 MP32 MP42	MP1 MP21 MP31 MP41	Manual handle feed	Manual handle interrupt	Incremental feed
0	0	Least input increment × 1	Least input increment × 1	Least input increment × 1
0	1	Least input increment × 10	Least input increment × 10	Least input increment × 10
1	0	Least input increment × Mn	Least input increment × Mn	Least input increment × Mn
1	1	Least input increment × Nn	Least input increment × Nn	Least input increment × Nn

Signal address

<For 1-path control>

	#7	#6	#5	#4	#3	#2	#1	#0
G018	HS2D	HS2C	HS2B	HS2A	HS1D	HS1C	HS1B	HS1A
G019			MP2	MP1	HS3D	HS3C	HS3B	HS3A

<For 2-path control>

	#7	#6	#5	#4	#3	#2	#1	#0
G018	HS2D #1	HS2C #1	HS2B #1	HS2A #1	HS1D #1	HS1C #1	HS1B #1	HS1A #1
G019			MP2#1	MP1#1	HS3D#1	HS3C#1	HS3B#1	HS3A#1
G1018	HS2D #2	HS2C #2	HS2B #2	HS2A #2	HS1D #2	HS1C #2	HS1B #2	HS1A #2
G1019			MP2#2	MP1#2	HS3D#2	HS3C#2	HS3B#2	HS3A#2

<Series 20i>

	#7	#6	#5	#4	#3	#2	#1	#0
G018	HS2D	HS2C	HS2B	HS2A	HS1D	HS1C	HS1B	HS1A
G019			MP2	MP1	HS3D	HS3C	HS3B	HS3A
G020					HS4D	HS4C	HS4B	HS4A
G087	MP42	MP41		MP32	MP31		MP22	MP21

Parameter

	#7	#6	#5	#4	#3	#2	#1	#0
7100			MPX	HPF			THD	JHD

[Data type] Bit

JHD Manual handle feed in JOG mode or incremental feed in the manual handle feed

0: Invalid

1: Valid

THD Manual pulse generator in TEACH IN JOG mode

- 0: Invalid
- 1: Valid

HPF When a manual handle feed exceeding the rapid traverse rate is issued,

- 0: The rate is clamped at the rapid traverse rate, and the handle pulses corresponding to the excess are ignored. (The graduations of the manual pulse generator may not agree with the distance the machine has traveled.)
- 1: The rate is clamped at the rapid traverse rate, and the handle pulses corresponding to the excess are not ignored, but stored in the CNC. (If the rotation of the manual pulse generator is stopped, the machine moves by the distance corresponding to the pulses preserved in the CNC, then stops.)

MPX Specify how to use manual handle feed distance selection signals in manual handle feed.

- 0: The signals for the first manual pulse generator (MP1, MP2 (G019#4, G019#5)) are used as the signals common to the first to the fourth (or the third for the T series) manual pulse generators.
- 1: The signals for the individual manual pulse generators are used independently of those for the other generators.

- First manual pulse generator: MP1, MP2 (G019#4, G019#5)
- Second manual pulse generator: MP21, MP22 (G087#0, G087#1)
- Third manual pulse generator: MP31, MP32 (G087#3, G087#4)
- Fourth manual pulse generator: MP41, MP42 (G087#6, G087#7)

NOTE

MPX (bit 5 of parameter No. 7100) is effective to the Series 20*i* only.

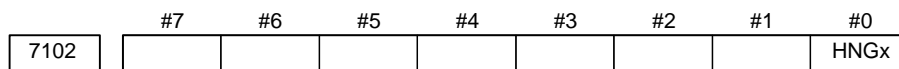

[Data type] Bit axis

HNGx Axis movement direction for rotation direction of manual pulse generator

- 0: Same in direction
- 1: Reverse in direction

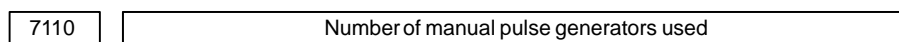

[Data type] Byte

[Valid data range] 1, 2, or 3

This parameter sets the number of manual pulse generators.

For the Series 20*i*, valid data range is below:

- 1, 2, 3 (T series)
- 1, 2, 3, 4 (F series)

7113	Manual handle feed magnification m
------	------------------------------------

[Data type] Word

[Unit of data] One time

[Valid data range] 1 to 127

This parameter sets the magnification when manual handle feed movement selection signal MP2 is on.

7114	Manual handle feed magnification n
------	------------------------------------

[Data type] Word

[Unit of data] One time

[Valid data range] 1 to 1000

This parameter sets the magnification when manual handle feed movement selection signals MP1 and MP2 are “1”.

7117	Allowable number of pulses that can be accumulated during manual handle feed
------	--

[Data type] 2-word

[Unit of data] Pulses

[Valid data range] 0 to 99999999

If manual handle feed is specified such that the rapid traverse rate will be momentarily exceeded, those pulses received from the manual pulse generator that exceed the rapid traverse rate are accumulated rather than canceled. This parameter sets the maximum number of pulses which can be accumulated in such a case.

7131	Manual handle feed magnification M ₂ /second manual pulse generator
------	--

7132	Manual handle feed magnification N ₂ /second manual pulse generator
------	--

7133	Manual handle feed magnification M ₃ /third manual pulse generator
------	---

7134	Manual handle feed magnification N ₃ /third manual pulse generator
------	---

7135	Manual handle feed magnification M ₄ /fourth manual pulse generator
------	--

7136	Manual handle feed magnification N ₄ /fourth manual pulse generator
------	--

[Data type] Word

[Unit of data] 1

[Valid data range] 1 to 1000

Specify a manual handle feed magnification.

For M_n, specify a magnification when manual handle feed travel distance select signal MP_{n2} is 1. For N_n, specify a magnification when manual handle feed travel distance select signals MP_{n1} and MP_{n2} are both 1.

NOTE

Parameter Nos. 7131 to 7136 are valid only in the Series 20*i*.

Warning**WARNING**

Rotating the handle quickly with a large magnification such as x100 moves the tool too fast or the tool may not stop immediately after the handle is no longer rotated or the distance the tool moves may not match the graduations on the manual pulse generator. The feedrate is clamped at the rapid traverse rate.

Caution**CAUTION**

Rotate the manual pulse generator at a rate of five rotations per second or lower.

Reference item

Series 16 <i>i</i> /18 <i>i</i> /160 <i>i</i> /180 <i>i</i> / 160 <i>is</i> /180 <i>is</i>	OPERATOR'S MANUAL (For Machining Center) (B-63534EN)	III.3.4	MANUAL HANDLE FEED
	OPERATOR'S MANUAL (For Lathe) (B-63524EN)	III.3.4	MANUAL HANDLE FEED
Series 21 <i>i</i> /210 <i>i</i> /210 <i>is</i>	OPERATOR'S MANUAL (For Machining Center) (B-63614EN)	III.3.4	MANUAL HANDLE FEED
	OPERATOR'S MANUAL (For Lathe) (B-63604EN)	III.3.4	MANUAL HANDLE FEED
Series 20 <i>i</i>	OPERATOR'S MANUAL (For Manual Milling Machine) (B-64204EN)	III.3.4	MANUAL HANDLE FEED
	OPERATOR'S MANUAL (For Manual Lathes) (B-64194EN)	III.3.4	MANUAL HANDLE FEED

3.3 MANUAL HANDLE INTERRUPTION

General

Rotating the manual pulse generator during automatic operation can increase the distance traveled by the amount corresponding to the handle feed. The axis to which the handle interrupt is applied is selected using the manual handle interrupt axis select signal.

The minimum travel distance per graduation is the least command increment. The minimum travel distance can be increased by tenfold or by two scale factors (parameter Nos. 7113 and 7114). Each scale factor can be selected using the manual handle travel distance select signal (Section 3.2, "Manual Handle Feed").

Signal

Manual Handle Interrupt Axis Selection Signal

- (M series) [Classification] Input signal

HS1IA – HS1ID
<G041#0 – #3>
HS2IA – HS2ID
<G041#4 – #7>
HS3IA – HS3ID
<G042#0 – #3>

[Function] These signals select an axis to which the manual handle interrupt is applied. There are three sets of signals, each corresponding to a manual pulse generator (up to three). Each set consists of four code signals A, B, C, and D. (For the T series (two-path control), each manual pulse generator has one set of signals for each tool post.) The number in each signal name corresponds to the number (position) of the manual pulse generator.

- (T series)

HS1IA – HS1ID
<G041#0 – #3>
HS2IA – HS2ID
<G041#4 – #7>

HS 1 IA

- | | |
|---|--|
| 1 | Selects the axis for which manual pulse generator No. 1 is used |
| 2 | Selects the axis for which manual pulse generator No. 2 is used |
| 3 | Selects the axis for which manual pulse generator No. 3 is used (M series) |

- (Two-path control)

HS1IA^{#1} – HS1ID^{#1}
<G041#0 – #3>
HS2IA^{#1} – HS2ID^{#1}
<G041#4 – #7>
HS3IA^{#1}–HS3ID^{#1} (M series)
<G042#0–#3>
HS1IA^{#2} – HS1ID^{#2}
<G1041#0 – #3>
HS2IA^{#2} – HS2ID^{#2}
<G1041#4 – #7>
HS3IA^{#2}–HS3ID^{#2} (M series)
<G1042#0–#3>

The correspondence between the code signals and the selected feed axis is similar to the correspondence of the manual handle feed axis select signals. See Section 3.2, "Manual Handle Feed."

● **Series 20i manual handle interrupt**

In the Series 20i, up to three (T series) or four (F series) manual handle pulse generators can be used. So, the following manual handle interrupt select signals are also valid for the Series 20i.

HS3IA to HS3ID <G042#0 to #3> (T series)

HS4IA to HS4ID <G088#4 to #7> (F series)

HS 1 I A

- 1 Selects an axis for which an interrupt is caused using the first manual pulse generator.
- 2 Selects an axis for which an interrupt is caused using the second manual pulse generator.
- 3 Selects an axis for which an interrupt is caused using the third manual pulse generator.
- 4 Selects an axis for which an interrupt is caused using the fourth manual pulse generator (F series).

Signal address

<For 1-path control >

	#7	#6	#5	#4	#3	#2	#1	#0
G041	HS2ID	HS2IC	HS2IB	HS2IA	HS1ID	HS1IC	HS1IB	HS1IA
G042					HS3ID	HS3IC	HS3IB	HS3IA

<For 2-path control>

	#7	#6	#5	#4	#3	#2	#1	#0
G041	HS2ID #1	HS2IC #1	HS2IB #1	HS2IA #1	HS1ID #1	HS1IC #1	HS1IB #1	HS1IA #1
G042					HS3ID #1	HS3IC #1	HS3IB #1	HS3IA #1
G1041	HS2ID #2	HS2IC #2	HS2IB #2	HS2IA #2	HS1ID #2	HS1IC #2	HS1IB #2	HS1IA #2
G1042					HS3ID #2	HS3IC #2	HS3IB #2	HS3IA #2

<Series 20i>

	#7	#6	#5	#4	#3	#2	#1	#0
G041	HS2ID	HS2IC	HS2IB	HS2IA	HS1ID	HS1IC	HS1IB	HS1IA
G042					HS3ID	HS3IC	HS3IB	HS3IA
G088	HS4ID	HS4IC	HS4IB	HS4IA				

Warning**WARNING**

The distance travelled by handle interruption is determined according to the amount by which the manual pulse generator is turned and the handle feed magnification (x1, x10, xM, xN).

Since the movement is not accelerated or decelerated, it is very dangerous to use a large magnification value for handle interruption.

Note**NOTE**

- 1 No handle interrupt can be used in manual handle feed mode.
- 2 Handle interruption is disabled when the machine is locked or interlocked.

Reference item

Series 16i/18i/160i/180i/ 160is/180is	OPERATOR'S MANUAL (For Machining Center) (B-63534EN)	III.4.8	MANUAL HANDLE INTERRUPTION
	OPERATOR'S MANUAL (For Lathe) (B-63524EN)	III.4.6	MANUAL HANDLE INTERRUPTION
Series 21i/210i/210is	OPERATOR'S MANUAL (For Machining Center) (B-63614EN)	III.4.7	MANUAL HANDLE INTERRUPTION
	OPERATOR'S MANUAL (For Lathe) (B-63604EN)	III.4.6	MANUAL HANDLE INTERRUPTION
Series 20i	OPERATOR'S MANUAL (For Manual Milling Machine) (B-64204EN)	III.4.7	MANUAL HANDLE INTERRUPTION
	OPERATOR'S MANUAL (For Manual Lathes) (B-64194EN)	III.4.5	MANUAL HANDLE INTERRUPTION

3.4 TOOL AXIS DIRECTION HANDLE FEED FUNCTION/ TOOL AXIS DIRECTION HANDLE FEED FUNCTION B (M SERIES)

The tool axis direction handle feed function allows the tool to be moved through a specified distance by handle feed in the axis direction of the tool, tilted by rotating the rotation axes.

Tool axis direction handle feed function B provides two functions: tool axis direction handle feed and tool axis perpendicular direction handle feed, which performs handle feed in the direction perpendicular to the tool axis.

3.4.1 Tool Axis Direction Handle Feed Function

General

By using the tool axis direction handle feed function, the tool can be moved in the axis direction of the tool by an amount equal to the manual pulse generator rotation.

Tool axis direction handle feed is enabled when the following four conditions are satisfied:

- (1) Handle mode is selected.
- (2) The tool axis direction handle feed mode signal is 1.

NOTE

When both the tool axis direction handle feed mode signal and tool axis perpendicular direction handle feed mode signal are 1, neither mode is enabled. In this case, normal handle mode is set.

- (3) In parameter No. 7121, the axis number for the first manual pulse generator is set as the tool axis direction handle feed mode axis.
- (4) A manual handle feed axis is selected for the axis set in parameter No. 7121.

Assume that the rotation axes for basic axes X, Y, and Z are A, B, and C, respectively. Assume also that the Z-axis represents the tool axis in the machine coordinate system. Then, depending on the axis configuration of the machine, four tool axis directions are available. Specify the desired type with parameter No. 7120.

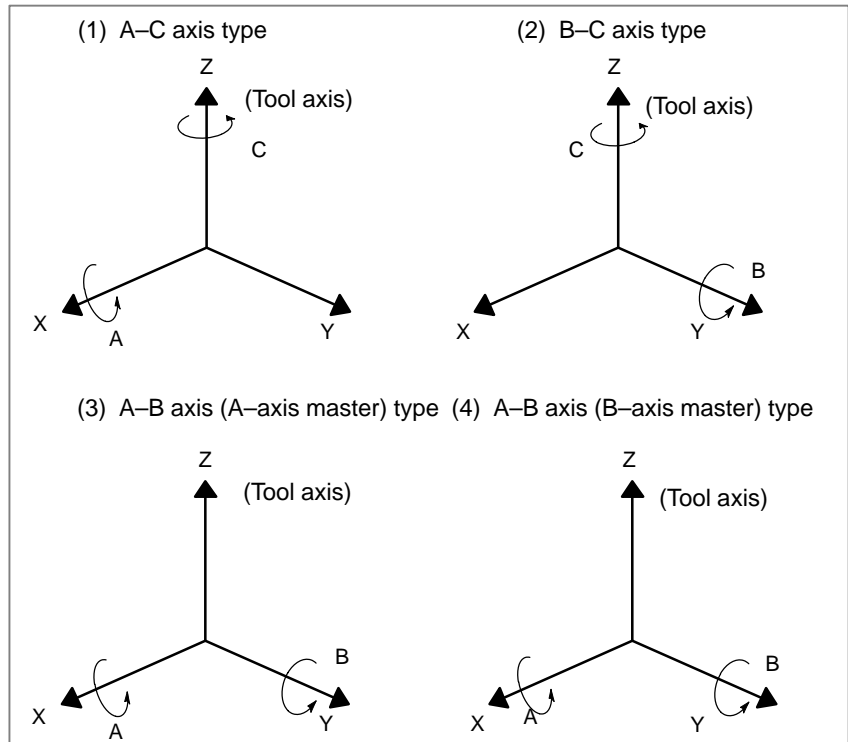

Output pulse (H_p) distribution by the manual pulse generator to the X-axis, Y-axis, and Z-axis for the four types is expressed below.

(1) A-C axis type

$$\begin{aligned} X_p &= H_p \times \sin(a) \times \sin(c) \\ Y_p &= -H_p \times \sin(a) \times \cos(c) \\ Z_p &= H_p \times \cos(a) \end{aligned}$$

(2) B-C axis type

$$\begin{aligned} X_p &= H_p \times \sin(b) \times \cos(c) \\ Y_p &= H_p \times \sin(b) \times \sin(c) \\ Z_p &= H_p \times \cos(b) \end{aligned}$$

(3) A-B axis type (A-axis master)

$$\begin{aligned} X_p &= H_p \times \sin(b) \\ Y_p &= -H_p \times \cos(b) \times \sin(a) \\ Z_p &= H_p \times \cos(b) \times \cos(a) \end{aligned}$$

(4) A-B axis type (B-axis master)

$$\begin{aligned} X_p &= H_p \times \cos(a) \times \sin(b) \\ Y_p &= -H_p \times \sin(a) \\ Z_p &= H_p \times \cos(a) \times \cos(b) \end{aligned}$$

In the above expressions, a, b, and c represent the positions (angles) of the A-axis, B-axis, and C-axis relative to the machine zero point; those values that are present when tool axis direction handle feed mode is set, or when a reset occurs, are used. To change the feed direction, reenter the tool axis direction handle feed mode, or press the reset key.

For tool axis direction handle feed B, the coordinates (angular displacements) of the rotation axes that determine the direction of the tool axis can be set. These coordinates are set using bits 3 and 4 (3D1 and 3D2) of parameter No. 7104, and parameter Nos. 7144 and 7145.

Signal

Tool axis direction handle feed mode signal ALNGH <G023#7>

[Classification] Input signal

[Function] This signal selects tool axis direction handle feed mode. When the following conditions are all satisfied, tool axis direction handle feed mode is set:

1. This signal is 1.
2. The value of the manual handle feed axis selection signal for the first manual pulse generator matches the value set in parameter No. 7121.
3. Handle mode is set.

NOTE

When both tool axis direction handle feed mode signal ALNGH and tool axis perpendicular direction handle feed mode signal RGHTH are set to 1, neither mode is set.

Signal address

	#7	#6	#5	#4	#3	#2	#1	#0
G023	ALNGH							

Parameter

● Settings for tool axis direction handle feed

	#7	#6	#5	#4	#3	#2	#1	#0
7104				3D2	3D1	CXC		TLX

[Data type] Bit

TLX When the tool axis direction handle feed or tool axis perpendicular direction handle feed function is used, this parameter selects the tool axis direction when the rotation axes for the three basic axes in the basic coordinate system are positioned at the machine zero point:

- 0 : Z-axis direction
- 1 : X-axis direction

- CXC** Tool axis direction handle feed or tool axis perpendicular direction handle feed is performed with:
- 0 : 5-axis machine.
 - 1 : 4-axis machine.
- 3D1** When the tool axis direction handle feed or tool axis perpendicular direction handle feed function is used, the coordinates of the first rotation axis are:
- 0: The machine coordinates when the tool axis direction handle feed mode or tool axis perpendicular direction handle feed mode is entered, or upon a reset.
 - 1: The value set in parameter No. 7144.
- 3D2** When the tool axis direction handle feed or tool axis perpendicular direction handle feed function is used, the coordinates of the second rotation axis are:
- 0: The machine coordinates when the tool axis direction handle feed mode or tool axis perpendicular direction handle feed mode is entered, or upon a reset.
 - 1: The value set in parameter No. 7145.

- **Axis configuration for using the tool axis direction handle feed function**

7120

Axis configuration for using the tool axis direction handle feed or tool axis perpendicular direction handle feed function
--

[Data type] Byte

[Valid data range] 1 to 4

When using the tool axis direction handle feed or tool axis perpendicular direction handle feed function. Define the rotation axes for the three basic axes X, Y, and Z in the basic coordinate system as axes A, B, and C, respectively, and the Z-axis represents the tool axis direction when the rotation axes are positioned to the machine zero point. Then, depending on the axis configuration of the machine, all four of the following types are available. When a 4-axis machine is used, and the tool axis perpendicular direction handle feed function is used, only types (1) and (2) are available.

- (1) A-C axis type
- (2) B-C axis type
- (3) A-B axis (A-axis master) type
- (4) A-B axis (B-axis master) type

This parameter selects a type, values of 1 to 4 are assigned to these types. When the X-axis represents the tool axis direction, the above types are changed to B-A axis type, C-A axis type, B-C axis (B-axis master) type, and B-C axis (C-axis master) type respectively.

- **Axis selection in the tool axis direction handle feed mode**

7121	Axis selection in tool axis direction handle feed mode
------	--

[Data type] Byte

[Valid data range] 1 to number of controlled axes

This parameter sets an axis number for the manual handle feed axis selection signal, for the first manual pulse generator to enable tool axis direction handle feed mode. When the value set in this parameter matches the value of the manual handle feed axis selection signal, tool axis direction handle feed mode is enabled.

- **Rotation axis for using the tool axis direction handle feed function**

7144	Coordinates of the first rotation axis for using the tool axis direction handle feed or tool axis perpendicular direction handle feed function
7145	Coordinates of the second rotation axis for using the tool axis direction handle feed or tool axis perpendicular direction handle feed function

[Data type] Two-word

[Unit of data] 0.001 degree

[Valid data range] -360000 to 360000

When the tool axis direction handle feed or tool axis perpendicular direction handle feed function is used, and 3D1 and 3D2 (bits 3 and 4 of parameter No. 7104) are set to 1, parameter Nos. 7144 and 7145 are set the coordinates (angular displacements) of the first and second rotation axes, respectively. However, if CXC (bit 2 of parameter No. 7104) is set to 1, the coordinates of the second rotation axis is assumed to be 0 regardless of the settings of 3D2 and parameter No. 7145.

Alarm and message

No.	Message	Meaning
5015	A specified rotation axis does not exists.	In tool axis direction handle feed or tool axis perpendicular direction handle feed mode, a specified rotation axis does not exist.

Note

NOTE

- 1 The basic axes X, Y, and Z are determined by parameter No. 1022 (plane selection). The rotation axes A, B, and C are determined by parameter No. 1020 (axis name).
- 2 If one of the two axes specified by a type based on the axis configuration does not exist, alarm P/S 5015 is issued.

Reference item

Series 16i/18i/160i/180i/ 160is/180is	OPERATOR'S MANUAL (For Machining Center) (B-63534EN)	III.3.6	Tool axis direction handle feed / Tool axis direction handle feed B
---	--	---------	--

3.4.2 Tool Axis Perpendicular Direction Handle Feed Function

General

This function moves the tool by an amount corresponding to the rotation of the manual pulse generator handle, in the direction specified relative to the tilt of the rotation axis.

Tool axis perpendicular direction handle feed is enabled when the following four conditions are satisfied:

- (1) Handle mode is selected.
- (2) The tool axis perpendicular direction handle feed mode signal is 1.

NOTE

When both the tool axis direction handle feed mode signal and tool axis perpendicular direction handle feed mode signal are 1, neither mode is enabled. In this case, normal handle mode is set.

- (3) In parameter Nos. 7141 and 7142, the axis number for the first manual pulse generator is set as the tool axis perpendicular direction handle feed mode axis.
- (4) A manual handle feed axis is selected for the axis set in parameter Nos. 7141 and 7142.

Assume that the rotation axes for basic axes X, Y, and Z are A, B, and C, respectively. When the direction of the tool axis corresponds to the Z-axis in the machine coordinate system, either rotation of axis A or B rotates the tool axis, depending on the machine axis configuration type. For each type, feed in the X-axis direction and that in the T-axis direction are defined as described below. Specify the desired type with parameter No. 7120.

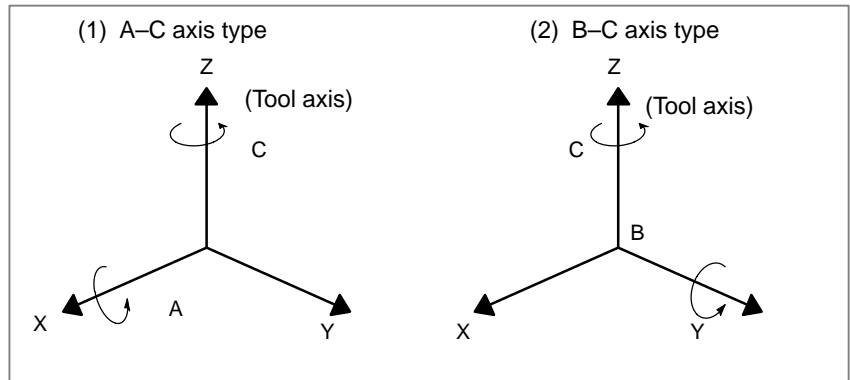

Output pulse (H_p) distribution by the manual pulse generator to the X-axis, Y-axis, and Z-axis for the four types is expressed below.

(1) A-C axis type (X axis direction)

$$\begin{aligned} X_p &= H_p \times \cos(c) \\ Y_p &= -H_p \times \sin(c) \\ Z_p &= \phi \end{aligned}$$

(2) A-C axis type (Y axis direction)

$$\begin{aligned} X_p &= -H_p \times \cos(a) \times \sin(c) \\ Y_p &= H_p \times \cos(a) \times \cos(c) \\ Z_p &= H_p \times \sin(a) \end{aligned}$$

(3) B-C axis type (X axis direction)

$$\begin{aligned} X_p &= H_p \times \cos(b) \times \cos(c) \\ Y_p &= H_p \times \cos(b) \times \sin(c) \\ Z_p &= -H_p \times \sin(b) \end{aligned}$$

(4) B-C axis type (Y axis direction)

$$\begin{aligned} X_p &= -H_p \times \sin(c) \\ Y_p &= H_p \times \cos(c) \\ Z_p &= \phi \end{aligned}$$

In the above expressions, a, b, and c represent the positions (angles) of the A-axis, B-axis, and C-axis relative to the machine zero point; those values that are present when tool axis direction handle feed mode is set, or when a reset occurs, are used. To change the feed direction, reenter tool axis direction handle feed mode, or press the reset key.

The coordinates (angular displacement) of the rotation axis, required to determine the direction of the tool axis, can be specified by setting bits 3D1 and 3D2 (bits 3 and 4 of parameter No. 7104) and parameters No. 7144 and 7145.

Signal

Tool axis perpendicular direction handle feed mode signal RGHTH <G023#6>

[Classification] Input signal

[Function] This signal selects tool axis perpendicular direction handle feed mode. When the following conditions are all satisfied, tool axis direction handle feed mode is set:

1. This signal is 1.
2. The value of the manual handle feed axis selection signal for the first manual pulse generator matches the value set in parameter Nos. 7141 and 7142.
3. Handle mode is set.
4. The value of the axis configuration type specified in parameter No. 7120 is 1 or 2.

NOTE

When tool axis direction handle feed mode signal ALNGH and tool axis perpendicular direction handle feed mode signal RGHTh are both set to 1, neither mode is set.

Signal address

	#7	#6	#5	#4	#3	#2	#1	#0
G023		RGHTh						

Parameter

- Settings for tool axis perpendicular direction handle feed

	#7	#6	#5	#4	#3	#2	#1	#0
7104				3D2	3D1	CXC		TLX

[Data type] Bit

TLX When the tool axis direction handle feed or tool axis perpendicular direction handle feed function is used, this parameter selects the tool axis direction when the rotation axes for the three basic axes in the basic coordinate system are positioned to the machine zero point:

- 0 : Z-axis direction
- 1 : X-axis direction

CXC Tool axis direction handle feed or tool axis perpendicular direction handle feed is performed with:

- 0 : 5-axis machine.
- 1 : 4-axis machine.

3D1 When the tool axis direction handle feed or tool axis perpendicular direction handle feed function is used, the coordinates of the first rotation axis are:

0: The machine coordinates when the tool axis direction handle feed mode or tool axis perpendicular direction handle feed mode is entered, or upon reset.

1: The value set in parameter No. 7144.

3D2 When the tool axis direction handle feed or tool axis perpendicular direction handle feed function is used, the coordinates of the second rotation axis are:

0: The machine coordinates when the tool axis direction handle feed mode or tool axis perpendicular direction handle feed mode is entered, or upon a reset.

1: The value set in parameter No. 7145.

- **Axis configuration for using the tool axis perpendicular direction handle feed function**

7120

Axis configuration for using the tool axis direction handle feed or tool axis perpendicular direction handle feed function
--

[Data type] Byte

[Valid data range] 1 to 4

When using the tool axis direction handle feed or tool axis perpendicular direction handle feed function, define the rotation axes for the three basic axes X, Y, and Z in the basic coordinate system as axes A, B, and C, respectively, and the Z-axis represents the tool axis direction when the rotation axes are positioned to the machine zero point. Then, depending on the axis configuration of the machine, all four of the following types are available. When a 4-axis machine and the tool axis perpendicular direction handle feed function is used, only types (1) and (2) are available.

(1) A-C axis type

(2) B-C axis type

(3) A-B axis (A-axis master) type

(4) A-B axis (B-axis master) type

This parameter selects a type, values of 1 to 4 are assigned to these types. When the X-axis represents the tool axis direction, the above types are changed to B-A axis type, C-A axis type, B-C axis (B-axis master) type, and B-C axis (C-axis master) type respectively.

- **Axis selection setting in handle feed mode, in a direction perpendicular to the tool axis**

7141	Direction of the X-axis in handle feed mode, in a direction perpendicular to the tool axis
7142	Direction of the Y-axis in handle feed mode, in a direction perpendicular to the tool axis

[Data type] Byte

[Valid data range] 1 to 8

Specify the status of the axis selection signal for the first manual pulse generator to enable handle feed mode in a direction perpendicular to the tool axis. When these parameter settings correspond to the manual handle feed axis selection signal, handle feed mode in a direction perpendicular to the tool axis is enabled.

- **Rotation axis setting for handle feed function in a direction perpendicular to the tool axis**

7144	Coordinates of the first rotation axis for handle feed in the tool axis direction or handle feed in a direction perpendicular to the tool axis
7145	Coordinates of the second rotation axis for handle feed in the tool axis direction or handle feed in a direction perpendicular to the tool axis

[Data type] Two-word

[Unit of data] 0.001 degree

[Valid data range] -360000 to 360000

Specify the coordinates (angular displacement) of the first and second rotation axes used when bits 3D1 and 3D2 (bits 3 and 4 of parameter No. 7104) are both set to 1 in handle feed mode in the direction of the tool axis, or in a direction perpendicular to the tool axis. When the CXC bit (bit 2 of parameter No. 7104) is set to 1, the coordinates of the second rotation axis are assumed to be 0, neglecting of the values of bit 3D2 or these parameters.

Alarm and message

No.	Message	Meaning
5015	A specified rotation axis does not exists.	In tool axis direction handle feed or tool axis perpendicular direction handle feed mode, a specified rotation axis does not exist.

Note**NOTE**

- 1 The basic axes X, Y, and Z are determined by parameter No. 1022 (plane selection). The rotation axes A, B, and C are determined by parameter No. 1020 (axis name).
- 2 If one of the two axes specified by a type set based on the axis configuration does not exist, alarm P/S 5015 is issued. In handle feed mode in a direction perpendicular to the tool axis, either the A-C axis type or B-C axis type must be selected as the axis configuration type.

Reference item

Series 16i/18i/160i/180i/ 160is/180is	OPERATOR'S MANUAL (For Machining Center) (B-63534EN)	III.3.6	Tool axis direction handle feed / Tool axis direction handle feed B
---	--	---------	--

3.5 MANUAL LINEAR/CIRCULAR INTERPOLATION

General

In manual handle feed or jog feed, the following types of feed operations are enabled along with conventional single axis feed operation.

- Feed along a tilted straight line in the XY plane (M series) or ZX plane (T series) based on simultaneous 2-axis control (linear feed)
- Feed along a circle in the XY plane (M series) or ZX plane (T series) based on simultaneous 2-axis control (circular feed)

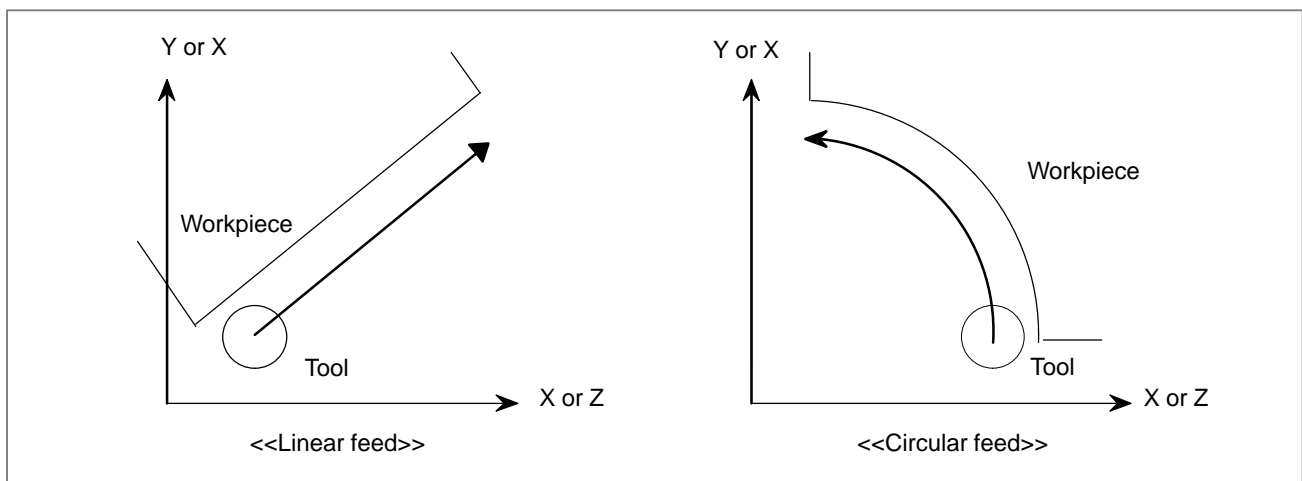

NOTE

The X-axis and Y-axis (M series) or Z-axis and X-axis (T series) must be the first two controlled axes. The following description applies to the X-Y plane for the M Series. For the T Series, read the X-Y plane as the Z-X plane.

Explanations

- **Line/circle definition**

A line or circle definition is not required for axial feed. For linear or circular feed, however, a line and circle must be defined, using the interface described later. (For example, circular feed, the center and radius of the circle must be specified.)

- **Interface area**

Part of the R area in the PMC is used for line and circle definitions. Set the necessary data in this area using PMC or macro executor. See the following descriptions for what data needs to be set at each address.

● **Data setting**

(a) Input data (PMC → CNC)

Lines and circles are defined by setting the data listed below.

	Data name	Number of bytes	Setting													
			Linear feed	Circular feed												
	R960	1	(Reserve) Do not use.													
(1)	R961	1	Linear or circular feed selection													
			<table border="1"> <thead> <tr> <th>Set value</th> <th>Description</th> </tr> </thead> <tbody> <tr> <td>0</td> <td>Neither linear or circular feed is performed.</td> </tr> <tr> <td>1</td> <td>Linear feed is carried out.</td> </tr> <tr> <td>2</td> <td>Clockwise circular feed is performed. (CW)</td> </tr> <tr> <td>3</td> <td>Counterclockwise circular feed performed out. (CCW)</td> </tr> </tbody> </table>		Set value	Description	0	Neither linear or circular feed is performed.	1	Linear feed is carried out.	2	Clockwise circular feed is performed. (CW)	3	Counterclockwise circular feed performed out. (CCW)		
Set value	Description															
0	Neither linear or circular feed is performed.															
1	Linear feed is carried out.															
2	Clockwise circular feed is performed. (CW)															
3	Counterclockwise circular feed performed out. (CCW)															
(2)	R962 to R965	4	Approach direction (X-axis direction)	Center of the circle (Xo)												
(3)	R966 to R969	4	Approach direction (Y-axis direction)	Center of the circle (Yo)												
(4)	R970 to R973	4	Distance (P) between the origin and a given line	Radius (R) of the circle												
(5)	R974	1	Direction of cutting (amount of travel corresponding to the forward rotation of the guidance handle)	Which is to be machined, the inside or outside of the circle?												
			<table border="1"> <thead> <tr> <th>Set value</th> <th>Description</th> </tr> </thead> <tbody> <tr> <td>0</td> <td>Direction towards +90° from the approach direction</td> </tr> <tr> <td>1</td> <td>Direction towards -90° from the approach direction</td> </tr> </tbody> </table>	Set value	Description	0	Direction towards +90° from the approach direction	1	Direction towards -90° from the approach direction	<table border="1"> <thead> <tr> <th>Set value</th> <th>Description</th> </tr> </thead> <tbody> <tr> <td>0</td> <td>Inside circle</td> </tr> <tr> <td>1</td> <td>Outside circle</td> </tr> </tbody> </table>	Set value	Description	0	Inside circle	1	Outside circle
Set value	Description															
0	Direction towards +90° from the approach direction															
1	Direction towards -90° from the approach direction															
Set value	Description															
0	Inside circle															
1	Outside circle															
(6)	R975	1	Control flags													
			<table border="1"> <tbody> <tr> <td>bit 0 to bit 6</td> <td>Must be 0.</td> </tr> <tr> <td>bit 7</td> <td>Limit function is: 0: Disabled 1: Enabled</td> </tr> </tbody> </table>		bit 0 to bit 6	Must be 0.	bit 7	Limit function is: 0: Disabled 1: Enabled								
bit 0 to bit 6	Must be 0.															
bit 7	Limit function is: 0: Disabled 1: Enabled															
	R976 to R978	3	(Reserve) Do not use.													
(7)	R979	1	Notify of changes in the setting													

(b) Output data (CNC → PMC)

The data listed below will be output. Do not change this data.

	Data name	Number of bytes	Description	
			Linear feed	Circular feed
(8)	R980 to R983	4	A distance from the current position to the given line is output.	A distance from the current position to the given circle is output.
	R984 to R989	6	(Reserve) Do not use.	

(1) Setting for linear feed

Assume that P is the length of a line segment starting at the origin and perpendicular to a given line, and θ is the angle between the perpendicular and the positive X -axis. The given line can be defined as:

$$X \cdot \cos\theta + Y \cdot \sin\theta = P$$

NOTE

The origin mentioned above is based on the absolute coordinate system. X and Y used in this description refer to coordinates of the absolute coordinate system. These coordinates represent the center of the tool.

Specify the following data:

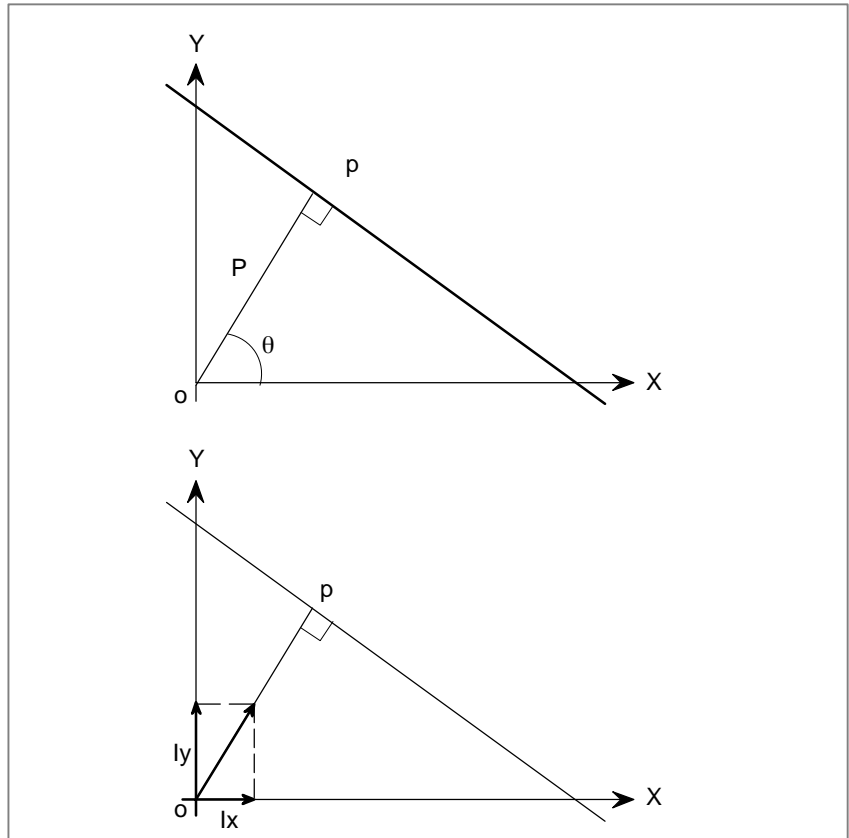
Data

- | | |
|-----------------|--|
| 1) R961 | : Linear feed |
| 2) R962 to R965 | : Approach direction $I_x \cdot 2^{30}$ |
| 3) R966 to R969 | : Approach direction $I_y \cdot 2^{30}$ |
| 4) R970 to R973 | : Distance P between the origin and a given line |
| 5) R974 | : Direction in which the guidance handle moves |
| 6) R975 | : Whether the limit function is enabled |
| 7) R979 | : Notice of changes in the setting |

- 1) Select linear feed. (R961)

Set R961 to 1.

- 2), 3) Specify the approach direction. (R962 to R969)

Specify the X and Y components (I_x , I_y) of a unit vector $(+\cos\theta, +\sin\theta)$ or $(-\cos\theta, -\sin\theta)$, which is parallel to perpendicular op , with four bytes. The setting value is multiplied by 2^{30} .

$$R962 \text{ to } R965 = I_x \times 2^{30}$$

$$R966 \text{ to } R969 = I_y \times 2^{30}$$

The tool moves in the direction indicated with this vector, when the approach handle is rotated in the forward direction.

- 4) Specify the length (P) of perpendicular op (line segment beginning at origin o and perpendicular to the given line) using 4 bytes. (R970 to R973)

Length P must satisfy the following equation:

$$P = +|\vec{op}|, \text{ where } +|\vec{op}| \text{ for } (+\cos\theta, +\sin\theta) \text{ or } -|\vec{op}| \text{ for } (-\cos\theta, -\sin\theta)$$

The unit of P is the least input increment. (Example: For IS-B with metric input, the unit of P is 0.001 mm.)

$$R970 \text{ to } R973 = P$$

- 5) Specify the cutting direction. (R974)

Specify the direction of travel, corresponding to the forward rotation of the guidance handle, with R974. The meaning of the setting is as follows:

0: Direction towards $+90^\circ$ from the approach direction

1: Direction towards -90° from the approach direction

- 6) Specify whether to enable the limit function. (Bit 7 of R975)

To disable the limit function, reset bit 7 of R975 to 0.

To enable the limit function, set bit 7 of R975 to 1.

When the limit function is enabled, it sets up an area which the tool is not allowed to enter. The area is delimited with a specified line. When you attempt to bring the tool into the prohibited area, using manual handle or jog feed, the tool decelerates and stops.

The prohibited area is set up as shown below, according to the setting of the approach direction (R962 to R965, R966 to R969).

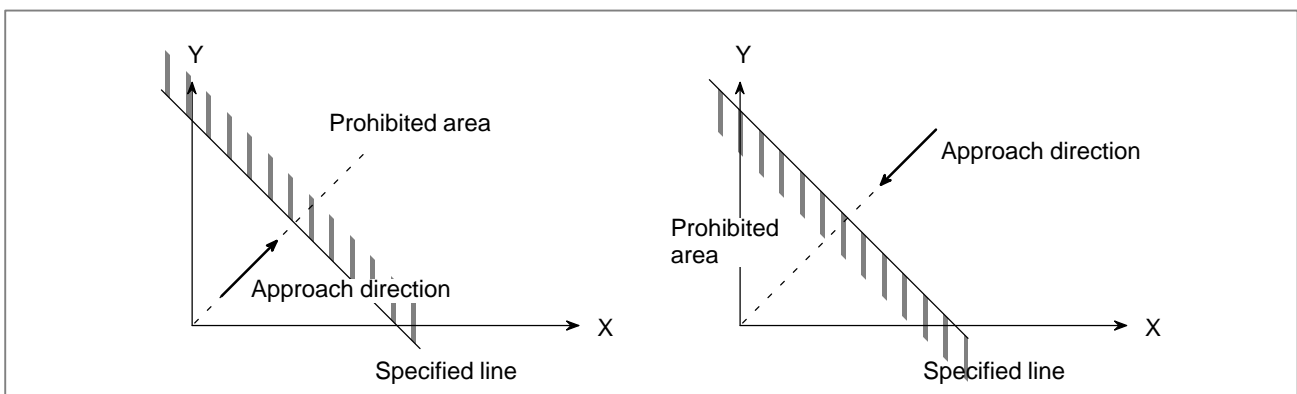

7) Notify changes in the setting (R979).

Reset R979 to 0.

CAUTION

1 Line and circle definitions (data items 1 to 6) can be set or changed during manual operation mode (manual handle or jog feed mode). This data notifies the CNC when the definitions are changed.

After setting data items 1 to 6, reset R979 (notice of changes in the setting) to 0. When the R979 value becomes 0, the CNC assumes that data items 1 to 6 (R961 to R975) are changed, and reads them, then sets R979 back to 1. Until R979 becomes 0 again, the CNC continues to carry out linear or circular feed according to the read data.

2 Do not set R979 (notice of changes in the setting) when any axis is running.

This is the end of line definition.

8) During linear feed, a distance to a given line is calculated, using the following equation, and output to R980 to R983 (4 bytes). The unit of the data is the least input increment.

$$f(X, Y) = P - (I_x \cdot X + I_y \cdot Y)$$

where X, Y: Current X- and Y-axis positions

(2) Setting for circular feed

Specify the data according to the procedure below.

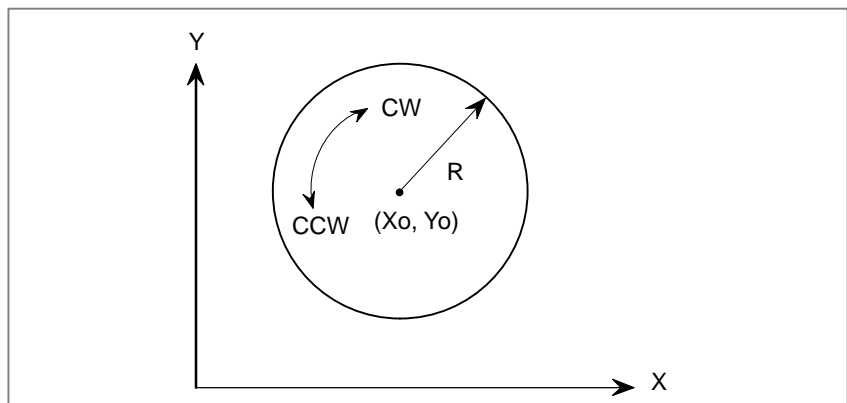

Data

- | | |
|-----------------|--|
| 1) R961 | : Circular feed and direction of rotation (CW/CCW) |
| 2) R962 to R965 | : Center of the circle Xo |
| 3) R966 to R969 | : Center of the circle Yo |
| 4) R970 to R973 | : Radius R |
| 5) R974 | : Which is to be machined, inside or outside? |
| 6) R975 | : Whether the limit function is enabled |
| 7) R979 | : Notice of changes in the setting |

- 1) Specify circular feed and the direction of circle rotation. (R961)

Set R961 to 2 or 3.

If R961 is 2, the tool moves along the circle clockwise, when the guidance handle is rotated in the forward direction. If R961 is 3, the tool moves along the circle counterclockwise, when the guidance handle is rotated in the forward direction.

- 2), 3) Specify the coordinates (Xo, Yo) of the center of the circle. (R962 to R965, R966 to R969)

NOTE

X and Y used in this description refer to coordinates in the absolute coordinate system.

R962 to R965 = Xo

R966 to R969 = Yo

Each coordinate is four bytes. The unit of the data is the least input increment.

- 4) Specify radius R. (R970 to R973)

R970 to R973 = R

The radius R is four bytes. The unit of the data is the least input increment.

- 5) Specify which is to be machined, the inside or outside of the circle. (R974)

Set R974 to 0 or 1.

If R974 is 0, the inside of the circle is machined. If R974 is 1, the outside of the circle is machined.

When the approach handle is rotated, the tool moves along a straight line normal to the specified circle. The direction of the tool movement is determined according to the setting of R974. When the approach handle is rotated in the forward direction, the direction of the tool movement (approach direction) is as follows:

- When the inside of the circle is to be machined (R974 = 0), the tool moves from the center of the circle to the circumference.
- When the outside of the circle is to be machined (R974 = 1), the tool moves toward the center of the circle.

- 6) Specify whether to enable the limit function. (bit 7 of R975)

To disable the limit function, set bit 7 of R975 to 0. To enable the limit function, set bit 7 of R975 to 1.

When the limit function is enabled, it sets up an area which the tool is not allowed to enter. The area is either inside or outside of the specified circle. When you attempt to bring the tool into the prohibited area, using manual handle or jog feed, the tool decelerates and stops.

Where (inside or outside of the circle) the prohibited area is set is determined according to the setting of R974 (which is to be machined, the inside or outside of the circle). If the inside of the circle is to be machined, the prohibited area is outside the circle. If the outside of the circle is to be machined, the prohibited area is inside the circle.

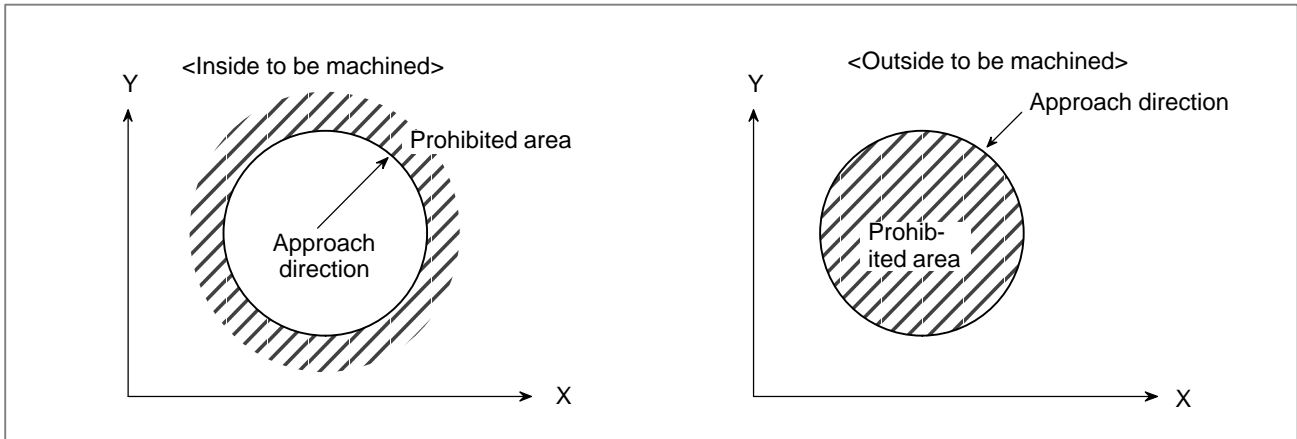

- 7) Notify changes in the setting (R979).
Reset R979 to 0.
This is the end of circle definition.
- 8) During circular feed, a distance to a given circle is calculated, using the following equation, and output to R980 to R983 (4 bytes). The unit of the data is the least input increment.
- When the inside is to be machined:

$$f(X, Y) = R - \sqrt{(X - X_0)^2 + (Y - Y_0)^2}$$

- When the outside is to be machined:

$$f(X, Y) = \sqrt{(X - X_0)^2 + (Y - Y_0)^2} - R$$

(3) Setting for linear and circular feed

Specify the following data:

Data	
1) R961	: 0 (Neither linear nor circular feed is carried out.)
2) R962 to R965	: (Need not be specified.)
3) R966 to R969	: (Need not be specified.)
4) R970 to R973	: (Need not be specified.)
5) R974	: (Need not be specified.)
6) R975	: (Need not be specified.)
7) R979	: Notice of changes in the setting

- 1) Linear or circular feed selection
Reset R961 to 0.
If R961 is 0, both the guidance and approach handles become ineffective. The tool will not move, even if these handles are rotated.
- 2) to 6) It is unnecessary to set R962 to R975.

- 7) Notify changes in the setting (R979).
Reset R979 to 0.
- 8) The values of R980 to R983 (distance to a given line or circle) are output as 0.

• Manual handle feed

In manual handle feed, the tool can be moved along a specified axis (X-axis, Y-axis, Z-axis, ..., or the 8th axis), or can be moved along a rotated straight line (linear feed) or a circle (circular feed).

(1) Feed along a specified axis (simultaneous 1-axis control)

By turning a manual handle, the tool can be moved along the desired axis (such as X-axis, Y-axis, and Z-axis) on a simultaneous 1-axis control basis. (This mode of feed is the conventional type of manual handle feed.)

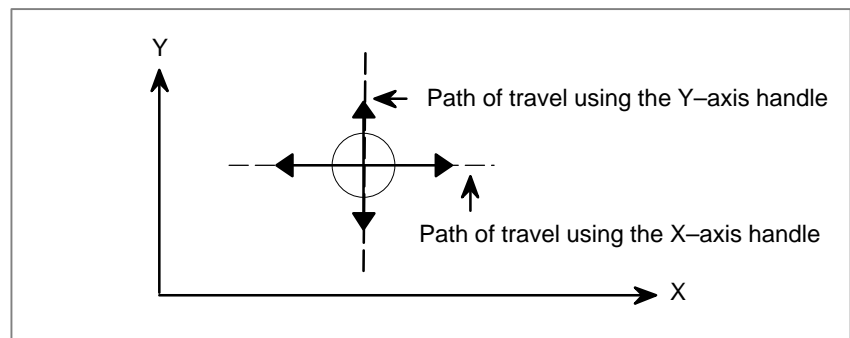

Feed along a specified axis

(2) Linear feed (simultaneous 2-axis control)

By turning a manual handle, the tool can be moved along the straight line parallel to a specified straight line on a simultaneous 2-axis control basis. This manual handle is referred to as the guidance handle. Moreover, if a second manual handle is used, the tool can be moved at right angles to a specified straight line on a simultaneous 2-axis control basis. The second manual handle is referred to as the approach handle. When the guidance handle or approach handle is turned clockwise or counterclockwise, the tool travels forward or backward along the respective path.

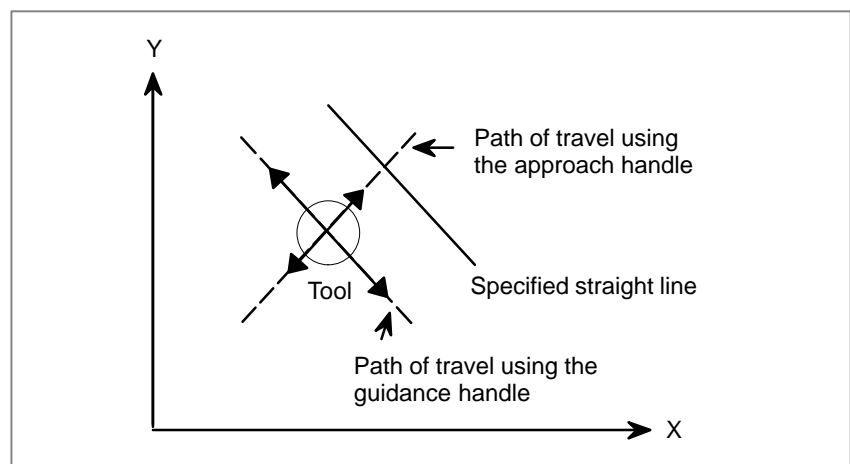

Linear feed

(3) Circular feed (simultaneous 2-axis control)

By turning a manual handle, the tool can be moved from the current position along a concentric circle that has the same center as a specified circle on a simultaneous 2-axis control basis. This manual handle is referred to as the guidance handle. Moreover, by turning another manual handle, the tool can be moved along the normal to a specified circle on simultaneous 2-axis control. This manual handle is referred to as the approach handle. When the guidance handle or approach handle is turned clockwise or counterclockwise, the tool travels forward or backward along the respective path.

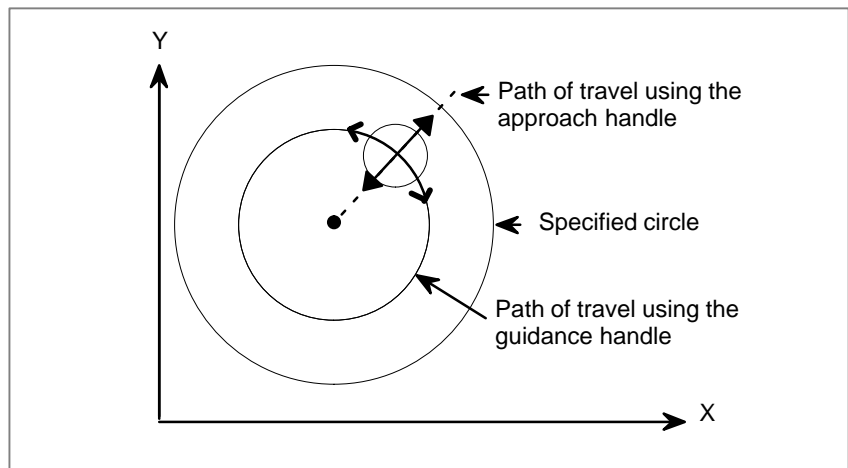

Circular feed

- **Feedrate for manual handle feed**

The feedrate depends on the speed at which a manual handle is turned. The distance to be traveled by the tool (along a tangent in the case of linear or circular feed) per a manual handle pulse can be selected using the manual handle feed travel distance magnification switch, MP1 or MP2.

- **Manual handle selection**

The M series has three (The T series has two) manual pulse generator interfaces to allow up to three (in T-series two) manual handles to be connected. The mode of the manual handles connected to the interfaces (whether to use each manual handle as a handle for feed along an axis, as a guidance handle, or as an approach handle), can be selected by Manual handle feed axis selection signals (HSnA, HSnB, HSnC, HSnD) in each interface. And by switching them, one manual handle can be used in plural purposes.

- **Direction of movement using manual handles**

The user can specify the direction of the tool moved along a straight line or circle (for example, whether to make a clockwise or counterclockwise movement along a circle) when the guidance handle or approach handle is turned clockwise or counterclockwise. For details, refer to the relevant manual provided by the machine tool builder.

- **Jog feed (JOG)**

In jog feed, the tool can be moved along a specified axis (X-axis, Y-axis, Z-axis, ..., or the 8th axis), or can be moved along a rotated straight line (linear feed) or a circle (circular feed).

(1) Feed along a specified axis (simultaneous 1-axis control)

While a feed axis and its direction are specified with the feed axis direction select switch, the tool moves in the specified axis direction at the feedrate specified in parameter No. 1423. The feedrate can be overridden using the manual feedrate override dial.

(2) Linear feed (simultaneous 2-axis control)

By defining a straight line, the tool can be moved as follows:

- While a feed axis and its direction are selected using the feed axis direction select switch, the tool moves along a straight line parallel to the specified straight line on a simultaneous 2-axis control basis.
- While a feed axis and its direction are selected using the feed axis direction select switch, the tool moves at right angles to the specified straight line on a simultaneous 2-axis control basis.

The feedrate in the tangential direction is specified in parameter No. 1410. The feedrate can be overridden (0.01% to 655.34%) using the manual feedrate override dial. (*JV0 to *JV15)

(3) Circular feed (simultaneous 2-axis control)

By defining a circle, the tool can be moved as follows:

- While a feed axis and its direction are selected using the feed axis direction select switch (+Jg, -Jg), the tool moves from the current position along the concentric circle that has the same center as the specified circle.
- While a feed axis and its direction are selected using the feed axis direction select switch (+Jg, -Jg), the tool moves along the normal to the specified circle.

The feedrate in the tangential direction is specified in parameter No. 1410. The feedrate can be overridden (0.01% to 655.34%) using the manual feedrate override dial. (*JV0 to *JV15)

- **Manual handle feed in JOG mode**

Even in JOG mode, manual handle feed can be enabled using bit 0 (JHD) of parameter No. 7100. In this case, however, manual handle feed is enabled only when the tool is not moved using jog feed.

- **Basic procedure**

(1) Select manual operation mode.

To perform manual handle feed, select manual handle feed mode. To perform jog feed, select jog feed mode.

(2) Define a line or arc.

See the relevant descriptions in the Explanations section.

(3) Move the tool using manual handle feed or jog feed.

To perform manual handle feed, select the axis along which the tool will move when the manual handle is turned (single-axis feed along the X-, Y-, or Z-axis, or simultaneous two-axis feed along a specified line or arc, involving both the X- and Y-axes), using manual handle feed axis selection signals HSnA, HSsB, HSsC, and HSsD.

Turning the manual handle will move the tool along the selected axis. The feedrate varies with the speed at which the manual handle is turned.

The amount by which the tool will be moved incrementing the manual handle one pulse can be specified using manual handle feed amount selection signals MP1 and MP2.

To perform jog feed, select the feed axis and the direction in which the tool is to be moved, using the feed axis and direction selection signals (+J1, -J1, +J2, -J2, ... +J8, -J8). While the feed axis and direction are selected, the tool is moved along the specified axis, or specified line or arc, at the parameter-set feedrate (jog feedrate).

Manual feedrate override signals (*JV0 to *JV15) can be used to apply an override (0.01% to 655.34%) to the feedrate.

Limitations

- **Mirror image**

Never use the mirror image function when performing manual operation. (Perform manual operation when the mirror image switch (MI1 to MI3) is off, and software mirror image setting is off.)

- **Two-path control**

Manual linear/circular interpolation can not used with two-path control.

Signal

The following signals determine the way in which jog feed or manual handle feed is executed.

Selection	Jog feed	Manual handle feed
Mode selection	MD1, MD2, MD4	MD1, MD2, MD4
Selection of the axis to move	+J1, -J1, +J2, -J2, +J3, -J3, ... +J8, -J8, +Jg, -Jg, +Ja, -Ja, ...	HS1A, HS1B, HS1C, HS1D, HS2A, HS2B, HS2C, HS2D, HS3A, HS3B, HS3C, HS3D
Selection of the direction to move the axis		
Selection of the move amount		MP1, MP2
Selection of feedrate	*JV0 – *JV15	

For the signals selecting the mode, see Section 2.6, “Mode Selection Signals.” For the manual handle feed selection signals, MP1 and MP2 of selection of the move amount, see 3.2 “Manual handle feed.” For manual feedrate override signals *JV0 – *JV15, see Section 3.1, “Jog feed/incremental feed.”

Other signals are described below.

Feed Axis and Direction Selection Signal

+J1 – +J8<G100>
–J1 – –J8<G102>
+Jg, –Jg, +Ja,
–Ja<G086>

[Classification] Input signal

[Function] Selects a desired feed axis and direction in jog feed or incremental feed. The sign (+ or –) in the signal name indicates the feed direction. The number following J indicates the number of the control axis.

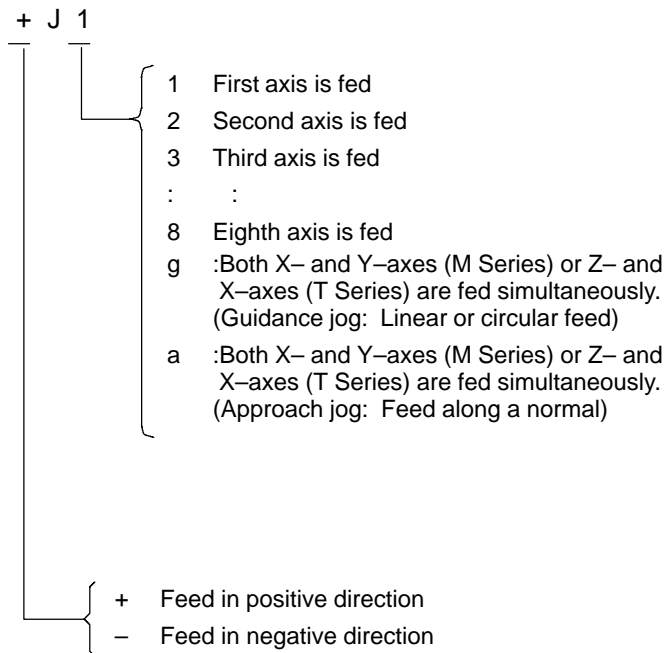

[Operation] See Section 3.1 for the operation.

**Manual Handle Feed
Axis Selection Signals**

- **(M series)** [Classification] Input signal
HS1A – HS1D [Function] Selects the axis of manual handle feed. A set of four code signals, A, B, C, and D is provided for each manual pulse generator. (Up to three generators can be used.) (For two-path, these signals are provided for each manual pulse generator and each path.) The number in the signal name indicates the number of the manual pulse generator to be used.
<G018#0 – #3>
HS2A – HS2D
<G018#4 – #7>
HS3A – HS3D
<G019#0 – #3>

- **(T series)**
HS1A – HS1D
<G018#0 – #3>
HS2A – HS2D
<G018#4 – #7>

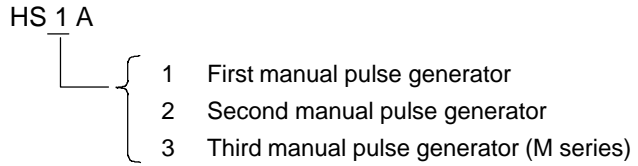

Code signals A, B, C, and D correspond to the feed axes as listed in the following table:

Manual handle feed axis selection				Feed axis
HSnD	HSnC	HSnB	HSnA	
0	0	0	0	No selection (None of axis is fed)
0	0	0	1	1st axis
0	0	1	0	2nd axis
0	0	1	1	3rd axis
0	1	0	0	4th axis
0	1	0	1	5th axis
0	1	1	0	6th axis
0	1	1	1	7th axis
1	0	0	0	8th axis
1	1	1	0	XY simultaneous 2 axes (M series) ZX simultaneous 2 axes (T series) (Guidance handle)
1	1	1	1	XY simultaneous 2 axes (M series) ZX simultaneous 2 axes (T series) (Approach handle)

● **Series 20i manual handle feed**

In the Series 20i, up to three (T series) or four (F series) manual handle pulse generators can be used. So, the following manual handle feed axis select signals are also valid for the Series 20i.

HS3A to HS3D <G019#0 to #3> (T series)

HS4A to HS4D <G020#0 to #3> (F series)

HS 1 A

- 1 Selects an axis for which feed is controlled using the first manual pulse generator.
- 2 Selects an axis for which feed is controlled using the second manual pulse generator.
- 3 Selects an axis for which feed is controlled using the third manual pulse generator.
- 4 Selects an axis for which feed is controlled using the fourth manual pulse generator (F series).

Signal address

	#7	#6	#5	#4	#3	#2	#1	#0
G100	+J8	+J7	+J6	+J5	+J4	+J3	+J2	+J1
G102	-J8	-J7	-J6	-J5	-J4	-J3	-J2	-J1
G086					-Ja	+Ja	-Jg	+Jg

	#7	#6	#5	#4	#3	#2	#1	#0
G018	HS2D	HS2C	HS2B	HS2A	HS1D	HS1C	HS1B	HS1A
G019					HS3D	HS3C	HS3B	HS3A

<Series 20i>

	#7	#6	#5	#4	#3	#2	#1	#0
G018	HS2D	HS2C	HS2B	HS2A	HS1D	HS1C	HS1B	HS1A
G019					HS3D	HS3C	HS3B	HS3A
G20					HS4D	HS4C	HS4B	HS4A

Parameter

1410	Dry run rate/Jog feedrate (linear feed, circular feed)
------	--

[Data type] Word

[Unit of data]

[Valid data range]

Increment system	Unit of data	Valid data range	
		IS-A, IS-B	IS-C
Millimeter machine	1 mm/min	6 – 15000	6 – 12000
Inch machine	0.1 inch/min	6 – 6000	6 – 4800

Set the dry run with auto operation rate or jog feedrate with linear feed or circular feed when the manual feedrate is overridden by 100%.

1423

Feedrate in manual continuous feed (jog feed) for each axis

[Data type] Word axis

(1) In M series, or in T series when JRV, bit 4 of parameter No. 1402, is set to 0 (feed per minute), specify a jog feedrate at feed per minute with an override of 100%.

[Unit of data]	Increment system	Unit of data	Valid data range
[Valid data range]	Millimeter machine	1 mm/min	6 – 32767
	Inch machine	0.1 inch/min	
	Rotation axis	1 deg/min	

(2) When JRV, bit 4 of parameter No. 1402, is set to 1 (feed per revolution) in T series, specify a jog feedrate (feed per revolution) under an override of 100%.

[Unit of data]	Increment system	Unit of data	Valid data range
[Valid data range]	Millimeter machine	0.01 mm/rev	0 – 32767
	Inch machine	0.001 inch/rev	
	Rotation axis	0.01 deg/rev	

	#7	#6	#5	#4	#3	#2	#1	#0
7100			MPX				THD	JHD

[Data type] Bit

JHD Manual handle feed in JOG mode or incremental feed in the manual handle feed

0 : Invalid

1 : Valid

THD Manual pulse generator in TEACH IN JOG mode

0 : Invalid

1 : Valid

MPX Specifies how the manual handle feed travel distance select signals are to be used as follows:

0 : The signals (MP1 and MP2; bits 4 and 5 of G019) for the first manual pulse generator are used for the first to fourth (F series) or third (T series) pulse generators in common.

1 : Each manual handle feed travel distance select signal is used for an individual manual pulse generator.

First manual pulse generator: MP1, MP2 (G019#4, G019#5)

Second manual pulse generator: MP21, MP32 (G087#0, G087#1)

Third manual pulse generator: MP31, MP32 (G087#3, G087#4)

Fourth manual pulse generator: MP41, MP42 (G087#6, G087#7)

NOTE

Parameter MPX (bit 5 of No. 7100) is valid only in the Series 20i.

7110	Number of manual pulse generators used
------	--

[Data type] Byte

[Valid data range] 1, 2, or 3

This parameter sets the number of manual pulse generators.
For Series 20*i*, valid data range is below:
1, 2, 3 (T series)
1, 2, 3, 4 (F series)

7113	Manual handle feed magnification m
------	------------------------------------

[Data type] Word

[Unit of data] One time

[Valid data range] 1 to 127

This parameter sets the magnification when manual handle feed movement selection signal MP2 is on.

7114	Manual handle feed magnification n
------	------------------------------------

[Data type] Word

[Unit of data] One time

[Valid data range] 1 to 1000

This parameter sets the magnification when manual handle feed movement selection signals MP1 and MP2 are "1".

7131	Manual handle feed magnification M ₂ /second manual pulse generator
------	--

7132	Manual handle feed magnification N ₂ /second manual pulse generator
------	--

7133	Manual handle feed magnification M ₃ /third manual pulse generator
------	---

7134	Manual handle feed magnification N ₃ /third manual pulse generator
------	---

7135	Manual handle feed magnification M ₄ /fourth manual pulse generator
------	--

7136	Manual handle feed magnification N ₄ /fourth manual pulse generator
------	--

[Data type] Word

[Unit of data] 1

[Valid data range] 1 to 1000

Specify a manual handle feed magnification.

For M_n, specify a magnification when manual handle feed travel distance select signal MP_n2 is 1. For N_n, specify a magnification when manual handle feed travel distance select signals MP_n1 and MP_n2 are both 1.

NOTE

Parameter Nos. 7131 to 7136 are valid only in the Series 20*i*.

Reference item

Series 16 <i>i</i> /18 <i>i</i> /160 <i>i</i> /180 <i>i</i> / 160 <i>is</i> /180 <i>is</i>	OPERATOR'S MANUAL (For Machining Center) (B-63534EN)	III.3.7	Manual linear/circular interpolation
	OPERATOR'S MANUAL (For Lathe) (B-63524EN)	III.3.6	Manual linear/circular interpolation
Series 21 <i>i</i> /210 <i>i</i> /210 <i>is</i>	OPERATOR'S MANUAL (For Machining Center) (B-63614EN)	III.3.6	Manual linear/circular interpolation
Series 20 <i>i</i>	OPERATOR'S MANUAL (For Manual Milling Machine) (B-64204EN)	III.3.6	Manual linear/Circular interpolation
	OPERATOR'S MANUAL (For Manual Lathes) (B-64194EN)	III.3.6	Manual linear/Circular interpolation

3.6 HANDLE- SYNCHRONOUS FEED

General

Generally, tools are fed at a program-specified feedrate or at a feedrate that matches a dry run feedrate in cutting feed blocks (such as linear interpolation (G01) and circular interpolation (G02 and G03)) during automatic operation. However, this function enables the tool to be fed in synchronization with the rotation of a manual handle (manual pulse generator).

The manual handle feed axis select signals determine what manual handle the tool is to be synchronized with.

The feedrate for handle-synchronous feed is controlled in such a way that its tangential component is proportional to the rotation speed of the manual handle.

The travel distance of the tool per manual handle pulse (tangential component of the travel distance) is determined by the manual handle feed travel distance select signal.

How each signal is combined determines which feedrate (program-specified feedrate (F command), a dry run feedrate, or a feedrate synchronized with the rotation of the manual handle) is to be used in a cutting feed block, as listed below. These signals can be switched in the middle of a block.

Dry run signal DRN	Handle-synchronou s feed signal HDLF	Cutting feedrate
0	0	Program-specified feedrate
0	1	Feedrate synchronized with the rotation of the manual handle
1	0	Dry run feedrate
1	1	(Do not use)

NOTE

1 The direction of manual handle rotation does not influence the direction of tool movement. To put another way, rotating the manual handle backward does not cause the tool to reverse.

(Handle-synchronous feed ignores the sign of pulses from the manual pulse generator; the absolute values of pulses are used.

Therefore, the tool moves along a programmed path through a distance that matches the number of turns the manual handle is rotated regardless of the direction of rotation.)

2 Handle-synchronous feed cannot be used during manual operation. Even during automatic operation, handle-synchronous feed cannot be used in a rapid traverse block.

Signal

Handle-synchronous

feed signal HDLF

[Classification] Input signal

<G23#4>

[Function] This signal selects handle-synchronous feed. To put another way, it causes the cutting feedrate used during automatic operation to be synchronized with the rotation of the manual handle (manual pulse generator).

[Operation] When the signal is 1, the machine tool behaves as follows:
The cutting feedrate used during automatic operation is caused to synchronize with the rotation of the manual pulse generator; so it will not be a program-specified feedrate.

- The manual handle feed axis select signal specifies the manual pulse generator interface to which the target manual pulse generator is connected.
- The feedrate varies with the rotation speed of the manual pulse generator. The manual handle feed travel distance select signal specifies the tool's travel distance (tangential component) per pulse from the manual pulse generator.

Manual handle feed axis select signals

HS1A to HS1D

<G018#0 to #3>

HS2A to HS2D

<G018#4 to #7>

HS3A to HS3D

<G019#0 to #3>

[Classification] Input signal

[Function] Each of these signals selects the interface to which the manual pulse generator to be used for handle-synchronous feed is connected. The signal also selects the axis to be fed by the manual pulse generator during manual handle feed.

One set of these signals correspond to one manual pulse generator. Each set consists of four signals (A, B, C, and D). A number in each signal name corresponds to the number of an individual manual pulse generator.

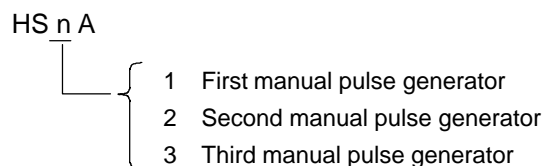

1 Selecting a feed axis for manual handle feed

The following table lists the relationships of code signals (A, B, C, and D) with feed axes.

Manual handle feed axis select signal				Feed axis
HSnD	HSnC	HSnB	HSnA	
0	0	0	0	Not selected (no feed axis)
0	0	0	1	First axis
0	0	1	0	Second axis
0	0	1	1	Third axis
0	1	0	0	Fourth axis
1	1	1	0	X- and Y-axes simultaneously (guidance handle)
1	1	1	1	X- and Y-axes simultaneously (approach handle)

NOTE

It is impossible to select the same axis using more than one pulse generator at a time.

2 Selecting a manual pulse generator to be used for handle-synchronous feed

Manual handle feed axis select signal				Selecting a manual pulse generator to be used for handle-synchronous feed
HSnD	HSnC	HSnB	HSnA	
0	0	0	0	Not used for handle-synchronous feed
0	0	0	1	
0	0	1	0	
0	0	1	1	
0	1	0	0	
1	1	1	0	Used for handle-synchronous feed
1	1	1	1	Not used for handle-synchronous feed

NOTE

Only one of the three manual pulse generators can be selected for handle-synchronous feed.

**Manual handle feed
travel distance select
signals
MP1, MP2
<G019#4, #5>**

[Classification] Input signal

[Function] Each of these signals selects the tool's travel distance per pulse from a manual pulse generator for handle-synchronous feed or manual handle feed. The tool is advanced through the travel distance selected using a manual handle feed travel distance select signal each time the manual pulse generator generates one pulse.

Manual pulse generator	Valid manual handle travel distance select signals	Parameter No. for setting a magnification	
		Mn	Nn
First to third pulse generators	MP1, MP2	No.7113	No.7114

The following table lists the distance through which the tool travels at one pulse from a manual pulse generator.

Manual handle feed travel distance select signal		Travel distance at handle-synchronous feed
MP2	MP1	Tool's travel distance per pulse from a manual pulse generator
0	0	Least input increment × 1
0	1	Least input increment × 10
1	0	Least input increment × Mn
1	1	Least input increment × Nn

**Feed zero signal
FEED 0
<F066#2>**

[Classification] Output signal

[Function] This signal indicates that the feedrate command (F command) is 0.

[Output condition] Outputting the feed zero signal (FEED0) requires that parameter FC0 (bit 7 of parameter No. 1404) be set to 1. If FC0 = 0, FEED0 is not output (is kept at 0) no matter whether the following conditions are satisfied. The feed zero signal is set to 1 under the following conditions:

- The feedrate command (F command) is reset to 0 when the power switched on or a reset occurs.
- A block containing a feedrate command (F command) that is 0 is executed during automatic operation.

The feed zero signal is reset to 0 under the following conditions:

- A block not containing a feedrate command (F command) that is 0 is executed during automatic operation.
- For the F series, the cutting feedrate (except 0) specified in parameter No. 1411 is made valid when the power is switched on or a reset occurs.
- Parameter FC0 (bit 7 of parameter No. 1404) is 0.

[Use] This signal is used when a cutting feedrate is to be determined using a dial on the operator’s panel.

CAUTION

On receiving a feed zero signal that is 1, the PMC returns a dry run signal or handle–synchronous feed signal. Before these signals become 1, the movement specified in a cutting feedrate block does not occur.

Signal address

	#7	#6	#5	#4	#3	#2	#1	#0
G018	HS2D	HS2C	HS2B	HS2A	HS1D	HS1C	HS1B	HS1A
G019			MP2	MP1	HS3D	HS3C	HS3B	HS3A
G023				HDLF				
G046	DRN							
F066						FEED0		

Parameter

7110	Number of manual pulse generators to be used
------	--

[Data type] Byte

[Valid data range] 1, and 2 (T series)

1, 2, and 3 (M series)

Specify the number of manual pulse generators to be used.

7113	Manual handle feed magnification m
------	------------------------------------

[Data type] Word

[Unit of data] One time

[Valid data range] 1 to 127

This parameter sets the magnification when manual handle feed movement selection signals MP1 and MP2 are set to 0 and 1.

7114	Manual handle feed magnification n
------	------------------------------------

[Data type] Word

[Unit of data] One time

[Valid data range] 1 to 1000

This parameter sets the magnification when manual handle feed movement selection signals MP1 and MP2 are set to 1.

Movement selection signal		Movement (Manual handle feed)
MP2	MP1	
0	0	Least input increment × 1
0	1	Least input increment × 10
1	0	Least input increment × m
1	1	Least input increment × n

	#7	#6	#5	#4	#3	#2	#1	#0
1404	FC0							

[Data type] Bit

FC0 Specifies the behavior of the machine tool when a block (G01, G02, G03, etc.) containing a feedrate command (F command) that is 0 is issued during automatic operation, as follows:

0 : A P/S alarm (No. 011) is displayed, and the block is not executed.

1 : No alarm is displayed, and the block is executed.

3.7 MANUAL RIGID TAPPING (M SERIES)

General

To execute rigid tapping, set rigid mode, then switch to handle mode and move the tapping axis with a manual handle.

Manual rigid tapping is enabled by setting bit 0 (HRG) of parameter No. 5203 to 1.

• Basic Procedure

1 Stop the spindle and servo axes, then set MDI mode by using the MDI mode selection switch.

2 Enter and execute the following program:

```
M29 S1000 ;
```

```
G91 G84 Z0 F1000 ;
```

The program above is required to determine a screw lead and set rigid tapping mode. In this program, a tapping axis must always be specified. Specify a value that does not move the tapping axis.

WARNING

In this MDI programming, never specify commands to position the tool at a drilling position and at point R. Otherwise, undesirable tool movement will occur.

3 When the MDI program is executed, rigid tapping mode is set.

4 After rigid mode is active upon completion of MDI program execution, switch to the handle mode by using the handle mode selection switch.

CAUTION

At this point, never press the reset key. Otherwise, rigid mode will be canceled.

5 To perform rigid tapping, select a tapping axis with the handle feed axis select switch, and move the tapping axis with the manual handle.

• Cancellation of rigid mode

To cancel rigid mode, specify G80, the same as normal cancellation of rigid tapping. When the reset key is pressed, rigid mode is canceled, but the canned cycle is not canceled.

When the rigid mode switch is to be set to “off” to cancel rigid mode (when bit 2 (CRG) of parameter No. 5200 is set to 0), the G80 command ends after the rigid mode switch is turned off.

• Spindle rotation direction

The rotation direction of the spindle is determined by a specified tapping cycle G code and setting bit 1 (HRM) of parameter No. 5203. For example, when the HRM parameter is set to 0 in G84 mode, the spindle makes forward rotations as the tapping axis moves in the minus direction. (When the tapping axis moves in the plus direction, the spindle makes reverse rotations.)

- **Arbitrary tapping axis** By setting bit 0 (FXY) of parameter No. 5101 to 1, an arbitrary tapping axis can be selected. In this case, specify a G code for plane selection and tapping axis address when rigid mode is commanded in MDI mode.
- **Specification of M29 and G84 in the same block** In an MDI program for setting rigid mode, G84 can be used as a rigid tapping G code, or M29 and G84 can be specified in the same block.
- **Acceleration/deceleration type** When manual rigid tapping is executed, the acceleration/deceleration type and acceleration/deceleration time constant specified in the rigid tapping parameters become valid.
- **Specification of manual handle feed faster than the rapid traverse rate** Set bit 0 (HPF) of parameter No. 7100 to 0 to ignore manual handle feed faster than the rapid traverse rate.

Limitations

- **Check for excessive error** In manual rigid tapping mode, only excessive error during movement is checked.
- **Tool-axis direction handle feed** Tool-axis direction handle feed cannot be performed.
- **Extraction override** In manual rigid tapping mode, an extraction override or extraction acceleration/deceleration time constant cannot be used.
- **Repetition count** Do not specify K0 or L0 (which sets the repetition count to 0, so that a G84 block will not be executed) in the MDI program.
- **Positioning to the drilling position** Positioning to the drilling position must be performed in handle mode, by selecting the X- or Y-axis using the axis selection signal. Do not perform positioning to the drilling position in MDI or MEM mode because this may cause the tapping axis to move.

Parameter

	#7	#6	#5	#4	#3	#2	#1	#0
5203							HRM	HRG

HRG Rigid tapping by the manual handle is:

- 0 : Disabled.
- 1 : Enabled.

HRM When the tapping axis moves in the negative direction during rigid tapping controlled by the manual handle, the direction in which the spindle rotates is determined as:

- 0 : In G84 mode, the spindle rotates in a normal direction. In G74 mode, the spindle rotates in reverse.
- 1 : In G84 mode, the spindle rotates in reverse. In G74 mode, the spindle rotates in a normal direction.

Reference item

Series 16i/18i/160i/180i/ 160is/180is	OPERATOR'S MANUAL (For Machining Center) (B-63534EN)	III.3.8	MANUAL RIGID TAPPING
CONNECTION MANUAL (This manual)		9.11	RIGID TAPPING
Series 20i	OPERATOR'S MANUAL (For Manual Milling Machine) (B-64204EN)	III.3.7	MANUAL RIGID TAPPING

3.8 MANUAL NUMERIC COMMAND

General

The manual numeric command function allows data programmed through the MDI to be executed in jog mode. Whenever the system is ready for jog feed, a manual numeric command can be executed. The following eight functions are supported:

- (1) Positioning (G00)
- (2) Linear interpolation (G01)
- (3) Automatic reference position return (G28)
- (4) 2nd/3rd/4th reference position return (G30)
- (5) M codes (miscellaneous functions)
- (6) S codes (spindle functions)
- (7) T codes (tool functions) (M series)
- (8) B codes (second auxiliary functions)

By setting the following parameters, the commands for axial motion and the M, S, T, and B functions can be disabled:

- (1) Positioning (G00)
 - (2) Linear interpolation (G01)
 - (3) Automatic reference position return (G28)
 - (4) 2nd/3rd/4th reference position return (G30)
 - (5) M codes (miscellaneous functions):
Bit 0 (JMF) of parameter No. 7002
 - (6) S codes (spindle functions):
Bit 1 (JSF) of parameter No. 7002
 - (7) T codes (tool functions) (M series):
Bit 2 (JTF) of parameter No. 7002
 - (8) B codes (second auxiliary functions):
Bit 3 (JBF) of parameter No. 7002
- } Bit 0 (JAXx) of parameter No. 7010

Explanations

- Positioning

An amount of travel is given as a numeric value, preceded by an address such as X, Y, or Z. This is always regarded as being an incremental command, regardless of whether G90 or G91 is specified.

The tool moves along each axis independently at the rapid traverse rate. Linear interpolation type positioning (where the tool path is linear) can also be performed by setting bit 1 (LRP) of parameter No. 1401.

	Manual rapid traverse selection switch	
	Off	On
Feedrate (parameter)	Jog feed rate for each axis (No. 1423)	Rapid traverse rate for each axis (No. 1420)
Automatic acceleration/deceleration (parameter)	Exponential acceleration/deceleration in jog feed for each axis (No. 1624)	Linear acceleration/deceleration in rapid traverse for each axis (No. 1620)
Override	Manual feed override	Rapid traverse override

NOTE

When the manual rapid traverse selection signal RT is 0, the jog feedrate for each axis is clamped by a parameter-set feedrate, determined by bit 1 (LRP) of parameter No. 1401 as shown below:

LRP = 0 : Manual rapid traverse rate for each axis
(parameter No. 1424)

LRP = 1 : Rapid traverse rate for each axis
(parameter No. 1420)

- **Linear interpolation (G01)**

The amount of travel is given as a numeric value, preceded by an address such as X, Y, or Z. It is always regarded as being an incremental command, regardless of whether G90 or G91 is specified. Axial movement is always performed in incremental mode even when scaling or polar coordinate interpolation is active. Also, movement is always performed in feed per minute mode regardless of the G94 or G95 specification.

Feedrate (parameter)	Dry run feedrate (No. 1410)
Automatic acceleration/deceleration (parameter)	Exponential acceleration/deceleration in cutting feed for each axis (No. 1622)
Override	Manual feed override

NOTE

Since the feedrate is always the dry run feedrate, regardless of the setting of dry run signal DRN, the feedrate cannot be specified using F. The feedrate is clamped so that the maximum cutting feedrate, set in parameter No. 1422, is not exceeded.

- **Automatic reference position return (G28)**

The tool returns directly to the reference position without passing through any intermediate points, regardless of the specified amount of travel. For those axes which no move command is specified, a return operation is not performed.

Feedrate (parameter)	Rapid traverse rate for each axis (No. 1420)
Automatic acceleration/deceleration (parameter)	Linear acceleration/deceleration in rapid traverse for each axis (No. 1620)
Override	Rapid traverse override

- **2nd, 3rd, or 4th reference position return (G30)**

The tool returns directly to the 2nd, 3rd, or 4th reference position without passing through any intermediate points, regardless of the specified amount of travel. To select a reference position, specify P2, P3, or P4 in address P. If address P is omitted, a return to the second reference position is performed.

Feedrate (parameter)	Rapid traverse rate for each axis (No. 1420)
Automatic acceleration/deceleration (parameter)	Linear acceleration/deceleration in rapid traverse for each axis (No. 1620)
Override	Rapid traverse override

NOTE

The function for 3rd/4th reference position return is optional.

- When the option is not available:
Return to the 2nd reference position is performed, regardless of the specification of address P.
- When the option is available:
If no of P2, P3, or P4 is specified, a "START IMPOSSIBLE" warning is generated, and the entered data is ignored.

- **M codes (miscellaneous functions)**

After address M, specify a numeric value no more than the number of digits specified by parameter No. 3030. When M98 or M99 is specified, it is executed but not output to the PMC.

NOTE

Neither subprogram calls nor custom macro calls can be performed using M codes.

- **S codes (spindle functions)**

After address S, specify a numeric value no more than the number of digits specified by parameter No. 3031.

NOTE

Subprogram calls cannot be performed using S codes.

- **T codes (M series) (tool functions)**

After address T, specify a numeric value no more than the number of digits specified by parameter No. 3032.

NOTE

Subprogram calls cannot be performed using T codes.

- **B codes
(second auxiliary
functions)**

After address B, specify a numeric value no more than the number of digits specified by parameter No. 3033.

NOTE

- 1 B codes can be named U, V, W, A, or C by setting parameter No. 3460. If the new name is the same as an axis name address, B is used. When B is used, and axis name B exists, B is used as the axis address. In this case, no second auxiliary function can be specified.
- 2 Subprogram calls cannot be performed using B codes.

- **Constant surface speed control**

S codes cannot be specified in constant surface speed control mode.

- **M, S, T, and B functions**

While automatic operation is halted, manual numeric commands can be executed. In the following cases, however, a warning is output, and command execution is disabled.

- (1) While an M, S, T, or B function is being executed, a manual numeric command containing an M, S, T, or B function cannot be executed.
- (2) While an M, S, T, or B function is being executed, either that function being specified alone, or a block specifying that function and any other function (such as a move command or dwell function) that has already been completed, a manual numeric command cannot be executed.

- **Jog feed**

When a manual numeric command is specified while the tool is being moved along an axis using the feed axis direction selection signal $\pm Jx$, the axial movement is interrupted, and the manual numeric command is executed. Therefore, the tool cannot be moved along an axis using the tool direction selection signal $\pm Jx$ during execution of a manual numeric command.

Parameter

	#7	#6	#5	#4	#3	#2	#1	#0
7001						JSL		

[Data type] Bit

JSL Specifies whether to output automatic operation signal STL during automatic operation based on a manual numeric command.

0 : Not output.

1 : Output.

	#7	#6	#5	#4	#3	#2	#1	#0
7002					JBF	JTF	JSF	JMF

[Data type] Bit

JMF Specifies whether to support the M function for the manual numeric command.

0 : Supported.

1 : Not supported.

JSF Specifies whether to support the S function for the manual numeric command.

0 : Supported.

1 : Not supported.

JTF Specifies whether to support the T function for the manual numeric command.

0 : Supported.

1 : Not supported.

JBF Specifies whether to support the B function for the manual numeric command.

0 : Supported.

1 : Not supported.

	#7	#6	#5	#4	#3	#2	#1	#0
7010								JAXx

[Data type] Bit axis

JAXx Specifies whether to support axis movement commands for the manual numeric command.

0 : Supported.

1 : Not supported.

Reference item

Series 16i/18i/160i/180i/ 160is/180is	OPERATOR'S MANUAL (For Machining Center) (B-63534EN)	III.3.9	Manual numeric command
	OPERATOR'S MANUAL (For Lathe) (B-63524EN)	III.3.7	Manual numeric command

3.9 STOP POSITION SETTING FOR JOG FEED

General

This function feeds the tool until the absolute coordinate value reaches a round number at the termination of jog feed or manual rapid traverse. This function operates only at the falling edge of the relevant feed axis direction selection signal <+J1 to +J8 or -J1 to -J8> in jog feed mode (JOG) or TEACH IN JOG mode (TJOG). It does not operate in the following cases:

- The feed operation is stopped by a reset.
- The feed operation is stopped by an emergency stop.
- The mode is changed.
- An alarm occurs (this function is disabled in the alarm state).
- The JOG override is set to 0%.
- Interlock is applied (see NOTE).
- The machine is in manual reference position return mode (REF).
- Three-dimensional coordinate conversion is performed for the axis.

Operation

The tool stops at a position ahead of the specified end point in the direction of travel at which the coordinate value is a round number. The tool continuously operates until it actually stops after the relevant feed axis direction selection signal <+J1 to +J8 or -J1 to -J8> is turned off. (At the end of the command, the tool does not wait for the remaining pulses caused by acceleration/deceleration are eliminated and no in-position check is performed.)

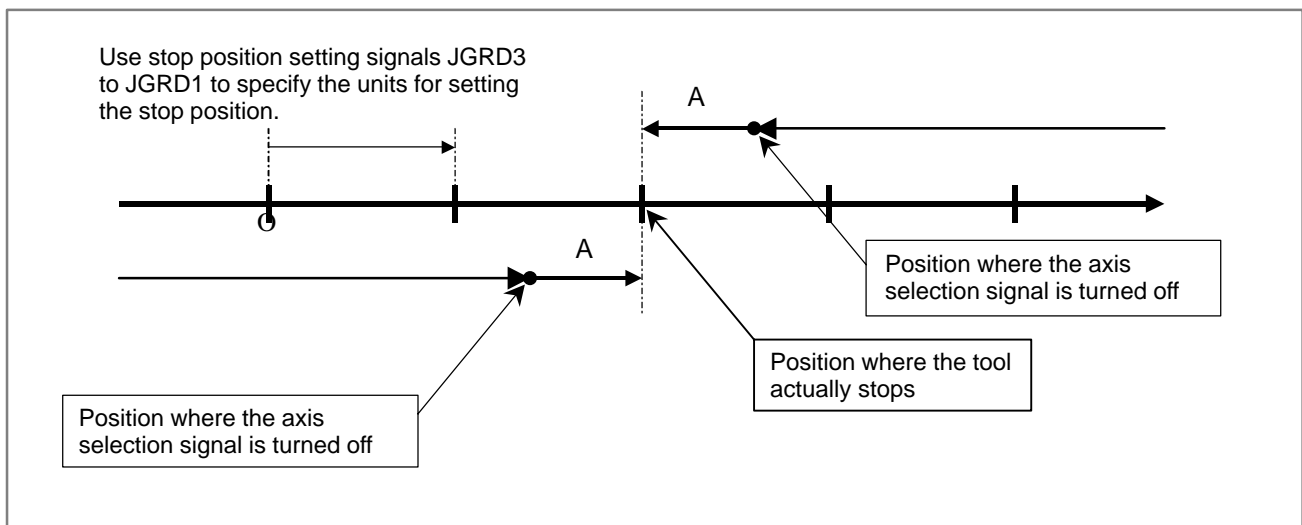

Section A in the figure indicates the operation for making the tool stop at a position at which the coordinate value is a round number by this function.

Signal

Signals for setting the jog feed stop position JGRD3 to JGRD1 <G201#5 to G201#3>

[Classification] Input signal

[Function] Sets a factor by which to multiply the least input increment to obtain the unit to be used by the function of setting the stop position for jog feed.

[Operation] When the relevant feed axis direction selection signal is turned off, the tool is controlled so that it stops at a position at which the coordinate value is a round number in the specified units.

JGRD3	JGRD2	JGRD1	Factor	
0	0	0	1 (invalid)	
0	0	1	10	The absolute coordinate value after the tool stops is xxxxxxx0.
0	1	0	100	The absolute coordinate value after the tool stops is xxxxxx00.
0	1	1	1,000	The absolute coordinate value after the tool stops is xxxxx000.
1	0	0	10,000	The absolute coordinate value after the tool stops is xxxx0000.
1	0	1	100,000	The absolute coordinate value after the tool stops is xxx00000.
1	1	0	1 (invalid)	
1	1	1	1 (invalid)	

Signal address

	#7	#6	#5	#4	#3	#2	#1	#0
G0201			JGRD3	JGRD2	JGRD1			

Note

NOTE

- 1 This function is disabled in the alarm state.
- 2 This function cannot be used together with the "least command increment change function" for jog feed. If the signals for both functions are input, the signal for the "least command increment change function" is effective.
- 3 When the relevant feed axis direction selection signal <+J1 to +J8 or -J1 to -J8> is turned off while the tool is being stopped by applying interlock in jog feed mode, this function is disabled. For this reason, the tool is not fed to a position at which the coordinate value is a round number even by releasing interlock after that.

3.10 HANDLE- SYNCHRONOUS FEED (Series 20i)

General

Generally, tools are fed at a program-specified feedrate or at a feedrate that matches a dry run feedrate in cutting feed blocks (such as linear interpolation (G01) and circular interpolation (G02 and G03)) during automatic operation. However, this function enables the tool to be fed in synchronization with the rotation of a manual handle (manual pulse generator).

The manual handle feed axis select signals determine what manual handle the tool is to be synchronized with.

The feedrate for handle-synchronous feed is controlled in such a way that its tangential component is proportional to the rotation speed of the manual handle.

The travel distance of the tool per manual handle pulse (tangential component of the travel distance) is determined by the manual handle feed travel distance select signal.

How each signal is combined determines which feedrate (program-specified feedrate (F command), a dry run feedrate, or a feedrate synchronized with the rotation of the manual handle) is to be used in a cutting feed block, as listed below. These signals can be switched in the middle of a block.

Dry run signal DRN	Handle-synchronous feed signal HDLF	Cutting feedrate
0	0	Program-specified feedrate
0	1	Feedrate synchronized with the rotation of the manual handle
1	0	Dry run feedrate
1	1	(Do not use)

NOTE

1 The direction of manual handle rotation does not influence the direction of tool movement. To put another way, rotating the manual handle backward does not cause the tool to reverse.

(Handle-synchronous feed ignores the sign of pulses from the manual pulse generator; the absolute values of pulses are used.

Therefore, the tool moves along a programmed path through a distance that matches the number of turns the manual handle is rotated regardless of the direction of rotation.)

2 Handle-synchronous feed cannot be used during manual operation. Even during automatic operation, handle-synchronous feed cannot be used in a rapid traverse block.

Signal

Handle-synchronous feed signal HDLF

[Classification] Input signal

<G23#4>

[Function] This signal selects handle-synchronous feed. To put another way, it causes the cutting feedrate used during automatic operation to be synchronized with the rotation of the manual handle (manual pulse generator).

[Operation] When the signal is 1, the machine tool behaves as follows:

The cutting feedrate used during automatic operation is caused to synchronize with the rotation of the manual pulse generator; so it will not be a program-specified feedrate.

- The manual handle feed axis select signal specifies the manual pulse generator interface to which the target manual pulse generator is connected.
- The feedrate varies with the rotation speed of the manual pulse generator. The manual handle feed travel distance select signal specifies the tool's travel distance (tangential component) per pulse from the manual pulse generator.

Manual handle feed axis select signals

HS1A to HS1D

<G018#0 to #3>

HS2A to HS2D

<G018#4 to #7>

HS3A to HS3D

<G019#0 to #3>

HS4A to HS4D

<G020#0 to #3>

[Classification] Input signal

[Function] Each of these signals selects the interface to which the manual pulse generator to be used for handle-synchronous feed is connected. The signal also selects the axis to be fed by the manual pulse generator during manual handle feed.

One set of these signals correspond to one manual pulse generator. Each set consists of four signals (A, B, C, and D). A number in each signal name corresponds to the number of an individual manual pulse generator.

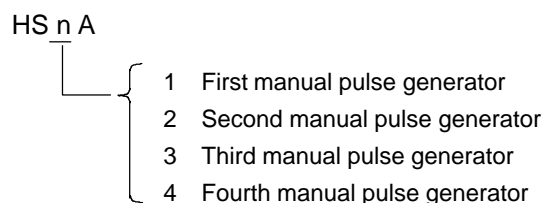

1 Selecting a feed axis for manual handle feed

The following table lists the relationships of code signals (A, B, C, and D) with feed axes.

Manual handle feed axis select signal				Feed axis
HSnD	HSnC	HSnB	HSnA	
0	0	0	0	Not selected (no feed axis)
0	0	0	1	First axis
0	0	1	0	Second axis
0	0	1	1	Third axis
0	1	0	0	Fourth axis
1	1	1	0	X- and Y-axes simultaneously (guidance handle)
1	1	1	1	X- and Y-axes simultaneously (approach handle)

NOTE

It is impossible to select the same axis using more than one pulse generator at a time.

2 Selecting a manual pulse generator to be used for handle-synchronous feed

Manual handle feed axis select signal				Selecting a manual pulse generator to be used for handle-synchronous feed
HSnD	HSnC	HSnB	HSnA	
0	0	0	0	Not used for handle-synchronous feed
0	0	0	1	
0	0	1	0	
0	0	1	1	
0	1	0	0	
1	1	1	0	Used for handle-synchronous feed
1	1	1	1	Not used for handle-synchronous feed

NOTE

Only one of the four manual pulse generators can be selected for handle-synchronous feed.

Manual handle feed travel distance select signals

MP1, MP2

<G019#4, #5>

MP21, MP22

<G087#0, #1>

MP31, MP32

<G087#3, #4>

MP41, MP42

<G087#6, #7>

[Classification] Input signal

[Function] Each of these signals selects the tool's travel distance per pulse from a manual pulse generator for handle-synchronous feed or manual handle feed. The tool is advanced through the travel distance selected using a manual handle feed travel distance select signal each time the manual pulse generator generates one pulse. Pulse generators are used in two different modes according to the state of bit 5 of parameter No. 7100 (MPX).

State of bit 5 of parameter No. 7100 (MPX)		Manual pulse generator	Valid manual handle travel distance select signals	Parameter No. for setting a magnification	
				Mn	Nn
1	If MPX = 0	First to fourth pulse generators	MP1, MP2	No.7113	No.7114
2	If MPX = 1	First pulse generator	MP1, MP2	No.7113	No.7114
		Second pulse generator	MP21, MP22	No.7131	No.7132
		Third pulse generator	MP31, MP32	No.7133	No.7134
		Fourth pulse generator	MP41, MP42	No.7135	No.7136

The following table lists the distance through which the tool travels at one pulse from a manual pulse generator.

Manual handle feed travel distance select signal		Travel distance at handle-synchronous feed
MP2 MP22 MP32 MP42	MP1 MP21 MP31 MP41	Tool's travel distance per pulse from a manual pulse generator
0	0	Least input increment × 1
0	1	Least input increment × 10
1	0	Least input increment × Mn
1	1	Least input increment × Nn

Feed zero signal**FEED 0****<F066#2>****[Classification]** Output signal**[Function]** This signal indicates that the feedrate command (F command) is 0.**[Output condition]** Outputting the feed zero signal (FEED0) requires that parameter FC0 (bit 7 of parameter No. 1404) be set to 1. If FC0 = 0, FEED0 is not output (is kept at 0) no matter whether the following conditions are satisfied.

The feed zero signal is set to 1 under the following conditions:

- The feedrate command (F command) is reset to 0 when the power switched on or a reset occurs.
- A block containing a feedrate command (F command) that is 0 is executed during automatic operation.

The feed zero signal is reset to 0 under the following conditions:

- A block not containing a feedrate command (F command) that is 0 is executed during automatic operation.
- For the F series, the cutting feedrate (except 0) specified in parameter No. 1411 is made valid when the power is switched on or a reset occurs.
- Parameter FC0 (bit 7 of parameter No. 1404) is 0.

[Use] This signal is used when a cutting feedrate is to be determined using a dial on the operator's panel.**CAUTION**

On receiving a feed zero signal that is 1, the PMC returns a dry run signal or handle-synchronous feed signal. Before these signals become 1, the movement specified in a cutting feedrate block does not occur.

Signal address

	#7	#6	#5	#4	#3	#2	#1	#0
G018	HS2D	HS2C	HS2B	HS2A	HS1D	HS1C	HS1B	HS1A
G019			MP2	MP1	HS3D	HS3C	HS3B	HS3A
G020					HS4D	HS4C	HS4B	HS4A
G023				HDLF				
G046	DRN							
G087	MP42	MP41		MP32	MP31		MP22	MP21
F066						FEED0		

Parameter

	#7	#6	#5	#4	#3	#2	#1	#0
7100			MPX					

[Data type] Bit

MPX Specifies how the manual handle feed travel distance select signals are to be used, as follows:

0 : The signals (MP1 and MP2; bits 4 and 5 of G019) for the first manual pulse generator are used for the first to fourth (F series) or third (T series) pulse generators in common.

1 : Each manual handle feed travel distance select signal is used for an individual manual pulse generator.

First manual pulse generator: MP1, MP2 (G019#4, G019#5)

Second manual pulse generator: MP21, MP22 (G087#0, G087#1)

Third manual pulse generator: MP31, MP32 (G087#3, G087#4)

Fourth manual pulse generator: MP41, MP42 (G087#6, G087#7)

7110	Number of manual pulse generators to be used
------	--

[Data type] Byte

[Valid data range] 1, 2, and 3 (T series)

1, 2, 3, and 4 (F series)

Specify the number of manual pulse generators to be used.

7131	Manual handle feed magnification M_2 /second manual pulse generator
7132	Manual handle feed magnification N_2 /second manual pulse generator
7133	Manual handle feed magnification M_3 /third manual pulse generator
7134	Manual handle feed magnification N_3 /third manual pulse generator
7135	Manual handle feed magnification M_4 /fourth manual pulse generator
7136	Manual handle feed magnification N_4 /fourth manual pulse generator

[Data type] Word

[Unit of data] 1

[Valid data range] 1 to 1000

Specify a manual handle feed magnification.

The following table lists the relationships between each manual handle feed travel distance select signal valid for an individual manual pulse generator and the parameter No. for specifying its magnification.

State of bit 5 of parameter No. 7100 (MPX)	Manual pulse generator	Valid manual handle travel distance select signals	Parameter for setting a magnification	
			Mn	Nn
If MPX = 0	First to fourth pulse generators	MP1, MP2	No.7113	No.7114
If MPX = 1	First pulse generator	MP1, MP2	No.7113	No.7114
	Second pulse generator	MP21, MP22	No.7131	No.7132
	Third pulse generator	MP31, MP32	No.7133	No.7134
	Fourth pulse generator	MP41, MP42	No.7135	No.7136

The following table lists the distance through which the tool travels at one pulse from a manual pulse generator.

Manual handle feed travel distance select signal		Travel distance at handle-synchronous feed
MP2 MP22 MP32 MP42	MP1 MP21 MP31 MP41	Tool's travel distance per pulse from a manual pulse generator
0	0	Least input increment × 1
0	1	Least input increment × 10
1	0	Least input increment × Mn
1	1	Least input increment × Nn

	#7	#6	#5	#4	#3	#2	#1	#0
1404	FC0							

[Data type] Bit

FC0 Specifies the behavior of the machine tool when a block (G01, G02, G03, etc.) containing a feedrate command (F command) that is 0 is issued during automatic operation, as follows:

0 : A P/S alarm (No. 011) is displayed, and the block is not executed.

1 : No alarm is displayed, and the block is executed.

4

REFERENCE POSITION ESTABLISHMENT



4.1 MANUAL REFERENCE POSITION RETURN

General

The tool is moved in the direction specified by parameter ZMI (bit 5 of No. 1006) setting the feed axis and direction select signal to “1” during manual reference position return mode. Movement will continue until the reference position is obtained.

Manual reference position return is performed by using a grid method. The reference position is based on an electrical grid, using on one-rotation signals received from the position detector.

- **Automatic setting of coordinate system**

When the option for workpiece coordinate system is not used, Bit 0 of parameter 1201 (ZPR) can be set to automatically preset the coordinate system after the manual reference position return. Parameter 1250 can be used to set the workpiece coordinate system, upon the completion of reference position return. The value set in the parameter sets the reference point of the tool holder or the tip position of the reference tool.

NOTE

Automatic coordinate system setting is not performed if the option for a workpiece coordinate system is used. In this case, manual reference position return always establishes a workpiece coordinate system based on the workpiece origin offsets, specified with parameters No. 1220 to 1226.

The following signals relate with the manual reference position return:

	Manual Reference Position Return
Mode selection	MD1, MD2, MD4
Selection of reference position return	ZRN, MREF
Selection of axis to be moved	+J1, -J1, +J2, -J2, +J3, -J3, ...
Selection of direction to be moved	
Selection of speed to be moved	ROV1, ROV2
Deceleration signal for reference position return	*DEC1, *DEC2, *DEC3, ...
Completion signal for reference position return	ZP1, ZP2, ZP3, ...
Reference position establishment signal	ZRF1, ZRF2, ZRF3, ...

Basic Procedure for Manual Reference Position Return

- (1) Select JOG mode or TEACH IN JOG mode, and the manual reference position return selection signal ZRN to “1”.
- (2) Feed a target axis toward the reference position by setting an appropriate feed axis and direction selection signal (+J1, -J1, +J2, -J2,...) “1”.
- (3) While the feed axis and direction selection signal is “1”, rapid traverse takes place along that axis. Although the rapid traverse override signals (ROV1, ROV2) are valid, the override is generally set to 100%.
- (4) When the reference position is approached, a limit switch installed on the machine is activated, making the deceleration signal (*DEC1, *DEC2, *DEC3,...) for reference position “0”. Consequently, the feedrate is decelerated to 0, then the tool is fed at a constant low speed (reference position return FL feedrate specified by parameter (No. 1425) setting).
- (5) When the deceleration signal returns to “1” again after the limit switch is passed, the tool is continues to feed, until the tool stops at the first grid point (electric grid point).
- (6) Upon confirmation that the current position is at the in-position area, the reference position return end signal (ZP1, ZP2, ZP3,...) and the reference position establishment signal (ZRF1, ZRF2, ZRF3,...) turn to “1”.

These steps are repeated for each axis. The number of simultaneously controlled axes is usually one, but it becomes three by setting parameter JAX (No. 1002#0).

If the feed axis direction selection signal (+J1, -J1, +J2, -J2,...) turns to “0” between step (2) and (4), the tool is stopped at once, and reference position return is canceled. If the signal turn to “1” again, operation resumes from step (3) (rapid traverse).

The timing charts for the basic procedures are given below.

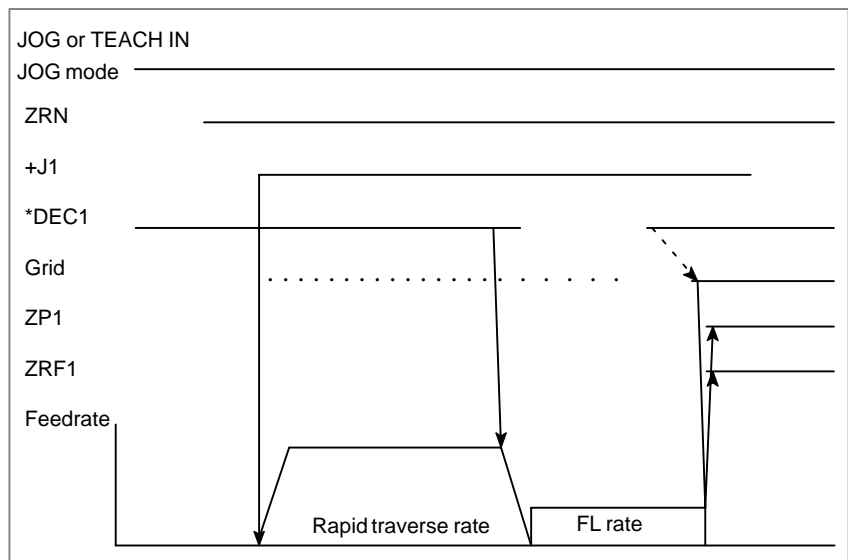

Installation conditions for deceleration limit switch

When installing the deceleration limit switch for manual reference position return, ensure that following conditions are satisfied:

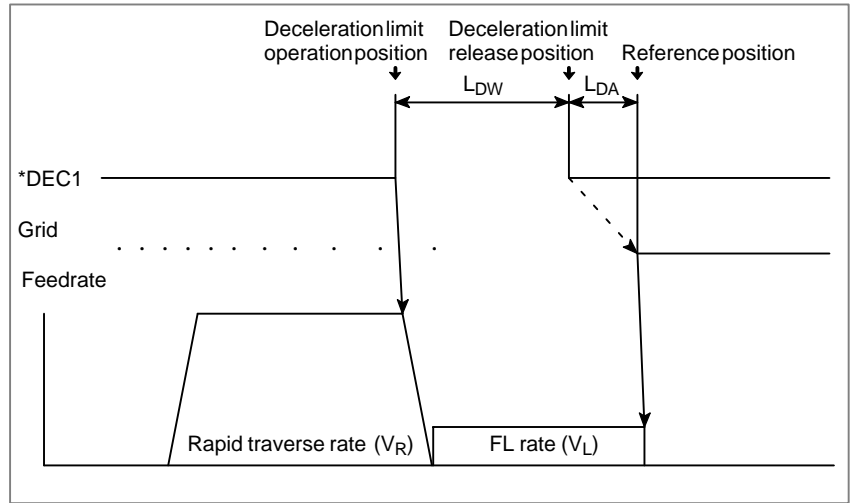

- L_{DW} : Deceleration dog width (mm or inch)

$$L_{DW} > \frac{V_R(\frac{T_R}{2} + 30 + T_S) + 4V_L \times T_S}{60 \times 1000}$$

V_R : Rapid traverse (mm/min or inch/min)

T_R : Rapid traverse time constant (ms)

T_S : Servo time constant (ms)

V_L : FL speed for reference position return (mm/min or inch /min)

- L_{DA} : Distance between deceleration limit switch released position and reference position

L_{DA} : Move amount of 1/2 revolution of motor

Since the above conditions do not include the limit switch operation variations, this point must also be considered at installation.

Servo position error and one-rotation signal

To perform the first manual reference position return after power on, the tool must be fed in manual reference position return mode, in the reference position return direction at a speed so that the servo position error exceeds the value set in parameter No. 1836. At that time, the tool must cross the grid line corresponding to a one-rotation signal from the position detector.

The servo position error is calculated from the following formula:

$$\text{Servo position error amount} = \frac{F \times 1000}{60} \times \frac{1}{G} \times \frac{1}{U}$$

F: Feedrate

G: Servo loop gain [s^{-1}]

U: Detection unit [μm]

(Example)

When the tool is fed at a feedrate F of 6000 mm/min with a servo loop gain G of $30 s^{-1}$ and a detection unit U of 1 μm , the servo position error is calculated as follows:

$$\begin{aligned} \text{Servo position error} &= \frac{6000 \times 1000}{60} \times \frac{1}{30} \times \frac{1}{1} \\ &= 3,333 \end{aligned}$$

By reversing the formula above, the following formula gives the feedrate F needed to obtain a servo position error of 128, when the servo loop gain G is 30 s^{-1} and the detection unit U is $1 \text{ }\mu\text{m}$:

$$F = \frac{128 \times 60}{1000} \times 30$$

$$= 230 \text{ [mm/min]}$$

Therefore, when the servo loop gain is 30 s^{-1} , the detection unit is $1 \text{ }\mu\text{m}$, and parameter No. 1836 is set to 128, the tool must be fed in the reference position return direction at a speed of at least 230 mm/min before completing manual reference position return.

Grid shift

The electronic grid can be shifted by the distance set in parameter 1850, thus shifting the reference position. The grid shift to be set in the parameter must not exceed the reference counter capacity (parameter No. 1821) (grid interval).

Signal

Manual reference position return selection signal ZRN <G043#7>

[Classification] Input signal

[Function] This signal selects manual reference position return. Manual reference position return is a kind of jog feed. Therefore, to select manual reference position return, it is required that the jog mode be selected and that the manual reference position return selection signal be set to "1".

[Operation] When the manual reference position return selection signal is set to "1", the control unit performs as described below.

- If jog feed mode is not selected, the control unit ignores the manual reference position return selection signal.
- If jog mode is selected, manual reference position return is enabled. In this case, the manual reference position return selection check signal MREF turns to "1".

NOTE

If the ZRN status changes state during jog feed, the feedrate is decelerated to 0. Then, to restart reference position return or jog feed, turn feed axis and direction selection signal to "0" then set it to "1".

Manual reference position return selection check signal MREF <F004#5>

[Classification] Output signal

[Function] This signal indicates that manual reference position return has been selected.

[Output condition] This signal turns to “1” when:

- Manual reference position return has been selected.

The signal turns to “0” when:

- The selection of manual reference position return has terminated.

Feed Axis and Direction Selection Signal

For details about this signal, see 3.1.2, “Feed Axis and Direction Selection Signal”. Only notes on use of reference position return are given, here.

NOTE

The direction of reference position return is set for each axis by parameter ZMI (No. 1006#5). If the tool is fed opposite to the preset direction in manual reference position return, while the deceleration signal is “0”, the tool feeds until the signal returns to “1”. The reference position return is then performed automatically in the predetermined direction.

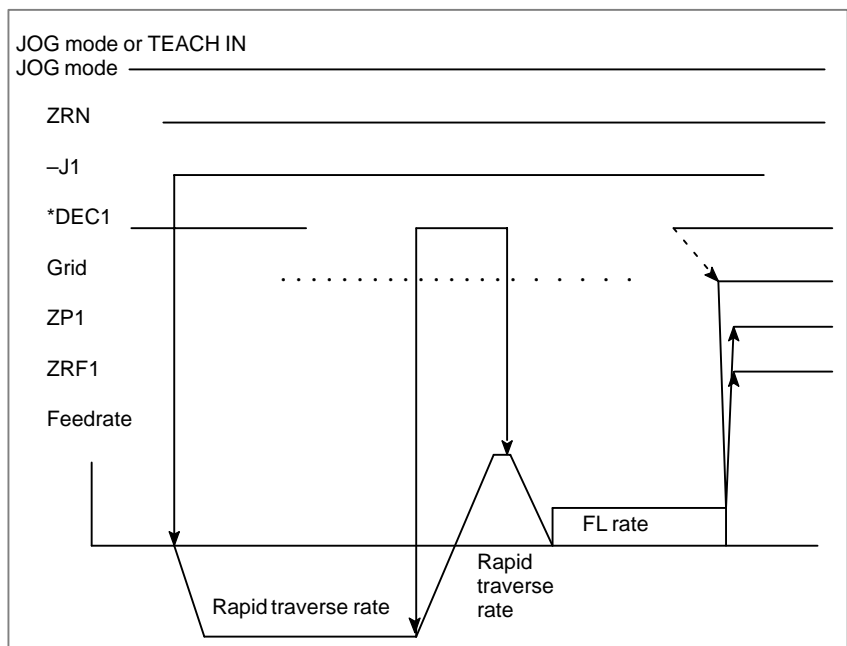

NOTE

When reference position return is selected, an axis who has already completed referencing movement along that axis is disabled while the reference position return selection signal (ZRN) is "1". To perform movement again, ZRN must be set "0", and the feed axis and direction selection signal must be reset to "0" and then returned to "1" again.

Reference position return deceleration signals *DEC1 to *DEC8 <X009>

[Classification] Input signal

[Function] These signals decelerate the feedrate for manual reference position return to a low feedrate (FL).

Deceleration signals are provided for each axis. The number appended to a deceleration signal represents a controlled axis number.

*DEC 1

- 1 : Reference position return deceleration signal for the first axis
- 2 : Reference position return deceleration signal for the second axis
- 3 : Reference position return deceleration signal for the third axis
- :
- :

[Operation] For a description of the control unit response to the deceleration signal, see the basic procedure for manual reference position return.

Reference position return end signals ZP1 to ZP8 <F094>

[Classification] Output signal

[Function] These signals report that the tool is at the refernce position on a controlled axis.

These siganls are provided for each axis.

The number appended to a signal represents a controlled axis number.

ZP 1

- 1 : Reference position return end signal for the first axis
- 2 : Reference position return end signal for the second axis
- 3 : Reference position return end signal for the third axis
- :
- :

[Output condition] These signals are set to “1” when:

- Manual reference position returns is completed, and the axis position is in the in-position area.
- Automatic reference position return (G28) is completed, and the axis position is in the in-position area.
- Reference position return check (G27) is completed, and the axis position is in the in-position area.

These signals turn to “0” when:

- The tool has moved from the reference position.
- An emergency stop is applied.
- A servo alarm is raised.

**Reference position establishment signal
ZRF1 to ZRF8<F120>**

[Classification] Output signal

[Function] Notify the system that the reference position has been established.

A reference position establishment signal is provided for each axis. The number appended to each signal indicates the number of the controlled axis.

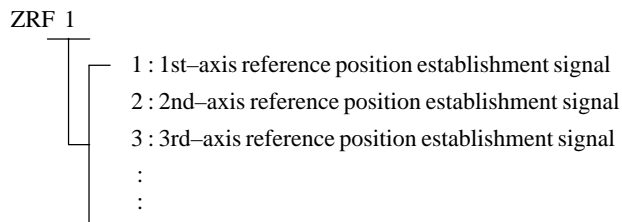

[Output condition] The signals are set to 1 in the following case:

- When the reference position is established after manual reference position return
- When the reference position is established using the absolute-position detector at initial power-on

The signals are set to 0 in the following case:

- When the reference position is lost

Signal address

	#7	#6	#5	#4	#3	#2	#1	#0
X009	*DEC8	*DEC7	*DEC6	*DEC5	*DEC4	*DEC3	*DEC2	*DEC1
	#7	#6	#5	#4	#3	#2	#1	#0
G043	ZRN							
	#7	#6	#5	#4	#3	#2	#1	#0
F004			MREF					
	#7	#6	#5	#4	#3	#2	#1	#0
F094	ZP8	ZP7	ZP6	ZP5	ZP4	ZP3	ZP2	ZP1
	#7	#6	#5	#4	#3	#2	#1	#0
F120	ZRF8	ZRF7	ZRF6	ZRF5	ZRF4	ZRF3	ZRF2	ZRF1

Parameter

	#7	#6	#5	#4	#3	#2	#1	#0
1002								JAX

[Data type] Bit

JAX Number of axes controlled simultaneously in JOG feed, manual rapid traverse and manual reference position return

0 : 1 axis

1 : 3 axes

	#7	#6	#5	#4	#3	#2	#1	#0
1005								ZRNx

[Data type] Bit axis

ZRNx When a command specifying the movement (except for G28) is issued in automatic operation (MEM, RMT, or MDI) before referencing is completed (after power on)

0 : An alarm is generated. (P/S alarm 224).

1 : No alarm is generated.

	#7	#6	#5	#4	#3	#2	#1	#0
1006			ZMlx					

NOTE

When this parameter is changed, you must power down the control before continuing.

[Data type] Bit axis

ZMlx The direction of reference position return

0 : Positive direction

1 : Negative direction

	#7	#6	#5	#4	#3	#2	#1	#0
1201						ZCL	ZPI	ZPR

[Data type] Bit

ZPR Automatic setting of a coordinate system when the manual reference position return is performed

0 : Not set automatically

1 : Set automatically

ZPI Coordinates at the reference position when a coordinate system is set automatically

0 : Value set in parameter No. 1250 is used.

1 : For input in mm, the value set in parameter 1250 is used, or for input in inches, the value set in parameter No. 1251 is used.

ZCL Local coordinate system when the manual reference position return is performed

0 : The local coordinate system is not canceled.

1 : The local coordinate system is canceled.

1240

Coordinate value of the reference position on each axis in the machine coordinate system

NOTE

After setting this parameter, turn the power off, then on again so that the setting will take effect.

[Data type] Two-word axis

[Unit of data]

Increment system	IS-A	IS-B	IS-C	Unit
Millimeter machine	0.01	0.001	0.0001	mm
Inch input	0.001	0.0001	0.00001	inch
Rotation axis	0.01	0.001	0.0001	deg

[Valid data range] -99999999 to 99999999

Set the coordinate values of the reference positions in the machine coordinate system.

1250

Coordinate value of the reference position on each axis used for setting a coordinate system automatically

[Data type] Two-word axis

[Unit of data]

Increment system	IS-A	IS-B	IS-C	Unit
Linear axis (input in mm)	0.01	0.001	0.0001	mm
Linear axis (input in inches)	0.001	0.0001	0.00001	inch
Rotation axis	0.01	0.001	0.0001	deg

[Valid data range] -99999999 to 99999999

Set the coordinate value of the reference position on each axis to be used for setting a coordinate system automatically.

1251

Coordinate value of the reference position on each axis used for setting a coordinate system automatically when input is performed in inches

[Data type] Two-word axis

[Unit of data]

Increment system	IS-A	IS-B	IS-C	Unit
Linear axis (input in inches)	0.001	0.0001	0.00001	inch

[Valid data range] -99999999 to 99999999

Set the coordinate value of the reference position on each axis to be used for setting a coordinate system automatically when input is performed in inches.

NOTE

This parameter is valid when ZPI in parameter 1201#1 is set to 1.

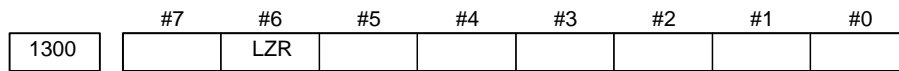

[Data type] Bit

LZR Checking of stored stroke limit 1 during the time from power-on to the manual reference position return

0 : The stroke limit 1 is checked.

1 : The stroke limit 1 is not checked

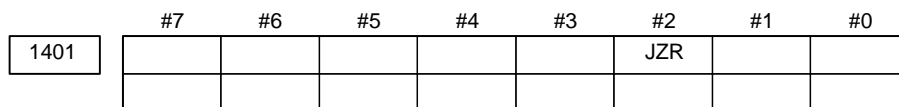

[Data type] Bit

JZR The manual reference position return at JOG feedrate

0 : Not performed

1 : Performed

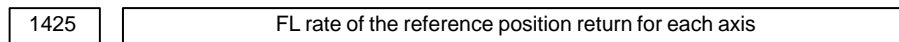

[Data type] Word axis

[Unit of data]

[Valid data range]

Increment system	Unit of data	Valid data range	
		IS-A, IS-B	IS-C
Millimeter machine	1 mm/min	6 – 15000	6 – 12000
Inch machine	0.1 inch/min	6 – 6000	6 – 4800
Rotaion axis	1 deg/min	6 – 15000	6 – 12000

Set feedrate (FL rate) after deceleration when the reference position return is performed for each axis.

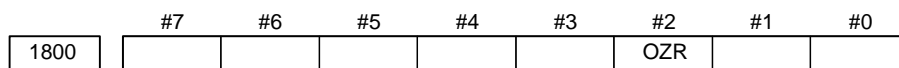

[Data type] Bit

OZR When manual reference position return is attempted in the halt state during automatic operation (feed hold stop state) under any of the conditions listed below:

0 : Manual reference position return is not performed, with P/S alarm No. 091.

1 : Manual reference position return is performed without an alarm occurring.

< Conditions >

- When there is a remaining distance to travel.
- When an auxiliary function (miscellaneous function, spindle-speed function, tool function) is being executed.
- When a dwell or cycle such as a canned cycle is being executed.

1821	Reference counter size for each axis
------	--------------------------------------

[Data type] Two-word axis

[Valid data range] 0 to 99999999

Set the size of the reference counter.

To set the size of the reference counter, specify the grid interval for the reference position return in the grid method.

$$\text{Size of the reference counter} = \frac{\text{grid interval}}{\text{detection unit}}$$

Grid interval = the amount of travel per rotation of the pulse coder

NOTE

When this parameter has been set, the power must be turned off before operation is continued.

1836	Servo error amount where reference position return is possible
------	--

[Data type] Byte axis

[Unit of data] Detection unit

[Valid data range] 0 to 127

This parameter sets the servo error used to enable reference position return in manual reference position return.

In general, set this parameter to 0. (When 0 is set, 128 is assumed as the default.)

WARNING

When bit 0 of parameter No. 2000 is set to 1, a value ten times greater than the value set in this parameter is used to make the check.

Example: When the value 10 is set in this parameter, and bit 0 of parameter No. 2000 is set to 1, reference position return operation is enabled when a servo error of 100 or more occurs.

1850	Grid shift for each axis
------	--------------------------

[Data type] Two-word axis

[Unit of data] Detection unit

[Valid data range] -99999999 to 99999999

A grid shift is set for each axis.

To shift the reference position, the grid can be shifted by the amount set in this parameter. Up to the maximum value counted by the reference counter can be specified as the grid shift.

NOTE

When this parameter has been set, the power must be turned off before operation is continued.

	#7	#6	#5	#4	#3	#2	#1	#0
3003			DEC					

[Data type] Bit

DEC Deceleration signal (*DEC1 to *DEC8) for manual reference position return

0 : Deceleration is applied when the signal is 0.

1 : Deceleration is applied when the signal is 1.

Alarm and message

Number	Message	Description
090	REFERENCE RETURN INCOMPLETE	<p>1. The reference position return cannot be performed normally because the reference position return start point is too close to the reference position or the speed is too slow. Separate the start point far enough from the reference position, or specify a sufficiently fast speed for reference position return.</p> <p>2. During reference position return with the absolute-position detector, if this alarm occurs even though condition 1 is satisfied, do the following: After turning the servo motor for the axis at least one turn, turn the power off and then on again. Then perform reference position return.</p>
091	REFERENCE RETURN INCOMPLETE	Manual reference position return cannot be performed in the feed hold state. Perform a manual reference position return in the automatic operation stop state or reset state.
224	RETURN TO REFERENCE POINT	Not returned to reference point before cycle start. (Only when parameter ZRNx (No. 1005#0). Do reference position return.

Reference item

Series 16i/18i/160i/180i/ 160is/180is	OPERATOR'S MANUAL (For Machining Center) (B-63534EN)	III.3.1	MANUAL REFERENCE POSITION RETURN
	OPERATOR'S MANUAL (For Lathe) (B-63524EN)	III.3.1	MANUAL REFERENCE POSITION RETURN
Series 21i/210i/210is	OPERATOR'S MANUAL (For Machining Center) (B-63614EN)	III.3.1	MANUAL REFERENCE POSITION RETURN
	OPERATOR'S MANUAL (For Lathe) (B-63604EN)	III.3.1	MANUAL REFERENCE POSITION RETURN
Series 20i	OPERATOR'S MANUAL (For Manual Milling Machine) (B-64204EN)	III.3.1	MANUAL REFERENCE POSITION RETURN
	OPERATOR'S MANUAL (For Manual Lathes) (B-64194EN)	III.3.1	MANUAL REFERENCE POSITION RETURN

4.2 SETTING THE REFERENCE POSITION WITHOUT DOGS

General

This function moves each axis in the manual continuous feed mode near the reference position. It then sets the reference position in the reference position return mode without the deceleration signal for reference position return. This is done by setting the feed axis and direction select signal to “1”. With this function, the machine reference position can be set at a given position without installing the limit switches for reference position return.

If the absolute-position detector is provided, the set reference position is retained after the power is turned off. In this case, when the power is turned on again, there is no need for setting the reference position again.

Basic Procedure for Setting the Reference Position Without Dogs

- (1) Feed the tool, along the axis for which the reference position is to be set, by manual continuous feed in the reference position return direction. Stop the tool near the reference position, but do not exceed the reference position.
- (2) Enter manual reference position return mode, then set 1 for the feed axis direction selection signal (for the positive or negative direction) for the axis.
- (3) The CNC positions the tool to the nearest grid line (based on one-rotation signals from the position detector) in the reference position return direction specified with bit 5 (ZMIx) of parameter No. 1006. The point at which the tool is positioned becomes the reference position.
- (4) The CNC checks that the tool is positioned to within the in-position area, then sets the completion signal for reference position return and the reference position establishment signal to 1.

The timing chart for the basic elements constituting steps (2) to (4) is shown below.

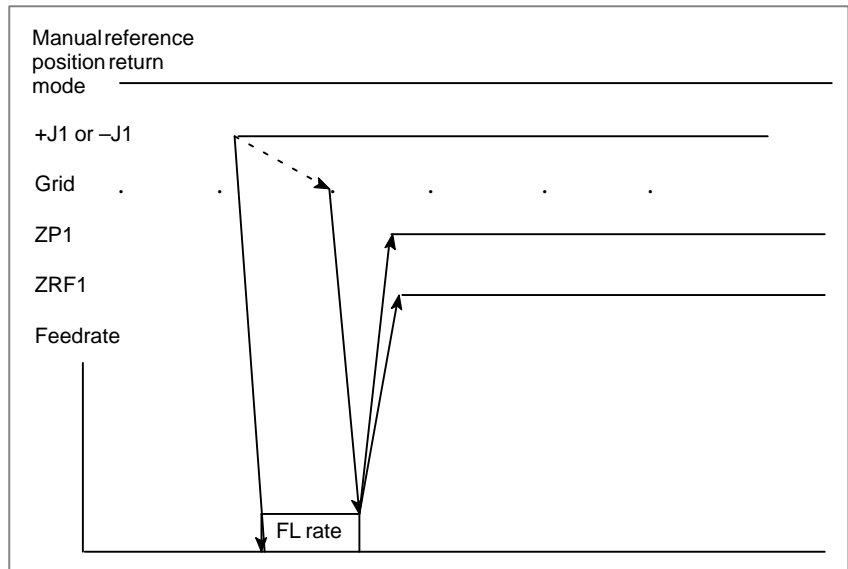

The following figure shows the positional relation between the reference position and the point to which the tool is positioned by manual continuous feed.

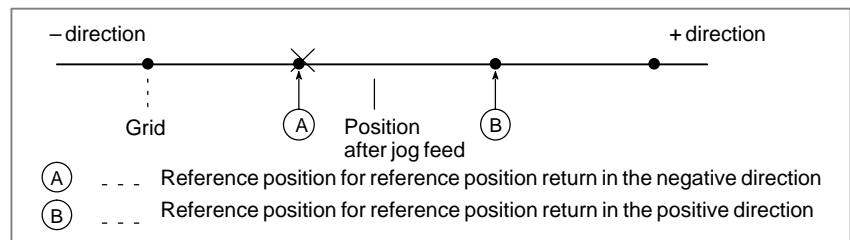

Servo position error and one-rotation signal

To set the reference position without dogs, when the reference position has not yet been established. The tool must be fed, in manual continuous feed mode, in the reference position return direction at such a speed that the servo position error exceeds the value set in parameter No. 1836. The tool must cross the grid line corresponding to a one-rotation signal from the position detector.

Section 4.1 explains how to calculate the servo position error.

Grid shift

To shift the reference position, the grid can be shifted by the distance set in parameter No. 1850. The grid shift to be set in the parameter must not exceed the reference counter capacity (parameter No. 1821).

Reference position return

When the feed axis and direction selection signal is set to 1 in manual reference position return mode after the reference position has been established, the tool is positioned to the reference position regardless of the direction specified by the feed axis and direction selection signal. The completion signal for reference position return is then set to 1.

Parameter

	#7	#6	#5	#4	#3	#2	#1	#0
1002							DLZ	JAX

[Data type] Bit

JAX Number of axes controlled simultaneously in manual continuous feed, manual rapid traverse and manual reference position return

0 : 1 axis

1 : 3 axes

DLZ Function for setting the reference position without dog (all axes)

0 : Disabled

1 : Enabled

NOTE

Bit 1 of parameter No.1002 (DLZ) is used to make common settings for all axes.

This function can be specified for each axis by DLZx, bit 1 of parameter No. 1005.

	#7	#6	#5	#4	#3	#2	#1	#0
1005							DLZx	ZRNx

[Data type] Bit axis

ZRNx When a command specifying the movement (except for G28) is issued in automatic operation (MEM, RMT, or MDI) and when a return to the reference position has not been performed since the power has been turned on

0 : An alarm is generated (P/S alarm 224).

1 : An alarm is not generated.

DLZx Function for setting the reference position without dogs (each axis)

0 : Disabled

1 : Enabled

NOTE

Bit 1 of parameter No.1005 (DLZx) is used to make settings for each axis.

When DLZ of parameter No. 1002#1 is 0, DLZx is enabled.

When DLZ of parameter No. 1002#1 is 1, DLZx is disabled, and the function for setting the reference position without dogs is enabled for all axes.

	#7	#6	#5	#4	#3	#2	#1	#0
1006			ZMlx					

NOTE

When this parameter is changed, turn off the power before continuing operation.

[Data type] Bit axis

ZMIx The direction of reference position return and the direction of initial backlash at power-on

- 0 : Positive direction
- 1 : Negative direction

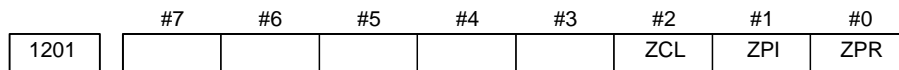

[Data type] Bit

ZPR Automatic setting of a coordinate system when the manual reference position return is performed

- 0 : Not set automatically
- 1 : Set automatically

ZPI Coordinates at the reference position when a coordinate system is set automatically

- 0 : Value set in parameter No. 1250 is used.
- 1 : For input in mm, the value set in parameter 1250 is used, or for input in inches, the value set in parameter No. 1251 is used.

ZCL Local coordinate system when the manual reference position return is performed

- 0 : The local coordinate system is not canceled.
- 1 : The local coordinate system is canceled.

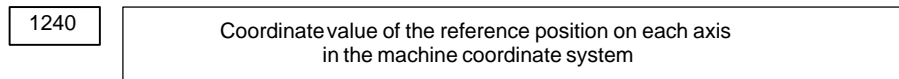

NOTE
After setting this parameter, turn the power off then on again so that the setting will take effect.

[Data type] Two-word axis

[Unit of data]	Increment system	IS-A	IS-B	IS-C	Unit
	Millimeter machine	0.01	0.001	0.0001	mm
	Inch input	0.001	0.0001	0.00001	inch
	Rotation axis	0.01	0.001	0.0001	deg

[Valid data range] -99999999 to 99999999

Set the coordinate values of the reference positions in the machine coordinate system.

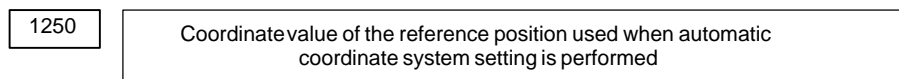

[Data type] Two-word axis

[Unit of data]	Increment system	IS-A	IS-B	IS-C	Unit
	Linear axis (input in mm)	0.01	0.001	0.0001	mm
	Linear axis (input in inches)	0.001	0.0001	0.00001	inch
	Rotation axis	0.01	0.001	0.0001	deg

[Valid data range] -99999999 to 99999999

Set the coordinate value for each axis to be used in setting a coordinate system automatically.

NOTE

This parameter is valid when ZPI in parameter 1201#1 is set to 1.

1251	Coordinate value of the reference position on each axis used for setting a coordinate system automatically when input is performed in inches
------	--

[Data type] Two-word axis

[Unit of data]	Increment system	IS-A	IS-B	IS-C	Unit
	Linear axis (input in inches)	0.001	0.0001	0.00001	inch

[Valid data range] -99999999 to 99999999

Set the coordinate value for each axis to be used in setting a coordinate system automatically when input is performed in inches.

NOTE

This parameter is valid when ZPI in parameter 1201#1 is set to 1.

	#7	#6	#5	#4	#3	#2	#1	#0
1300		LZR						

[Data type] Bit

LZR Checking of stored stroke limit 1 during the time from power-on to the manual position reference return
 0: The stroke limit 1 is checked.
 1: The stroke limit 1 is not checked

1425	FL rate of the reference position return for each axis
------	--

[Data type] Word axis

[Unit of data]	Increment system	Unit of data	Valid data range	
			IS-A, IS-B	IS-C
[Valid data range]	Millimeter machine	1 mm/min	6 - 15000	6 - 12000
	Inch machine	0.1 inch/min	6 - 6000	6 - 4800
	Rotation axis	1 deg/min	6 - 15000	6 - 12000

Set feedrate (FL rate) after deceleration when the reference position return is performed for each axis.

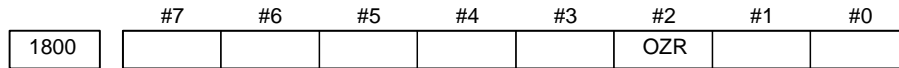

[Data type] Bit

OZR When manual reference position return is attempted in feed hold during automatic operation under any of the conditions listed below:

- 0: Manual reference position return is not performed, with P/S alarm No. 091.
- 1: Manual reference position return is performed without an alarm occurring.

< Conditions >

- When there is a remaining distance to travel.
- When an auxiliary function (miscellaneous function, spindle-speed function, tool function, B function) is being executed.
- When a dwell or cycle such as a canned cycle is being executed.

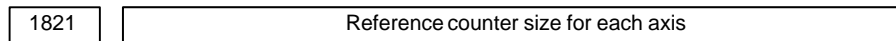

[Data type] Two-word axis

[Valid data range] 0 to 99999999

Set the size of the reference counter.

To set the size of the reference counter, specify the grid interval for the reference position return in the grid method.

$$\text{Size of the reference counter} = \frac{\text{grid interval}}{\text{detection unit}}$$

Grid interval = the amount of travel per rotation of the pulse coder

NOTE

When this parameter has been set, the power must be turned off before operation is continued.

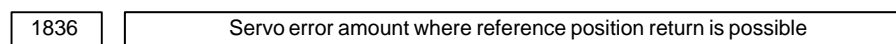

[Data type] Byte axis

[Unit of data] Detection unit

[Valid data range] 0 to 127

This parameter sets the servo error used to enable reference position return in manual reference position return.

In general, set this parameter to 0. (When 0 is set, 128 is assumed as the default.)

WARNING

When bit 0 of parameter No. 2000 is set to 1, a value ten times greater than the value set in this parameter is used to make the check.

Example: When the value 10 is set in this parameter, and bit 0 of parameter No. 2000 is set to 1, reference position return operation is enabled when a servo error of 100 or more occurs.

1850	Grid shift for each axis
------	--------------------------

[Data type] Two-word axis

[Unit of data] Detection unit

[Valid data range] -99999999 to 99999999

A grid shift is set for each axis.

To shift the reference position, the grid can be shifted by the amount set in this parameter. Up to the maximum value counted by the reference counter can be specified as the grid shift.

NOTE

When this parameter has been set, the power must be turned off before operation is continued.

Alarm and message

Number	Message	Description
090	REFERENCE RETURN INCOMPLETE	<p>1. The reference position return cannot be performed normally because the reference position return start point is too close to the reference position or the speed is too slow. Separate the start point far enough from the reference position, or specify a sufficiently fast speed for reference position return.</p> <p>2. During reference position return with the absolute-position detector, if this alarm occurs even though condition 1 is satisfied, do the following: After turning the servo motor for the axis at least one turn, turn the power off and then on again. Then perform reference position return.</p>
091	REFERENCE RETURN INCOMPLETE	Manual reference position return cannot be performed in the feed hold state. Perform a manual reference position return in the automatic operation stop state or reset state.
224	RETURN TO REFERENCE POINT	Not returned to reference position before cycle start. (Only when parameter ZRNx (No. 1005#0) =0). Do reference position return.

Note**NOTE**

P/S alarm No. 090 is issued when G28 is specified and the reference position has not yet be established.

4.3 REFERENCE POSITION SHIFT

General

When reference position return is performed using the grid method, the reference position can be shifted by a parameter-set distance without having to move the deceleration dog.

This function is enabled by setting bit 2 of parameter No. 1002 (SFD) to 1. When distance L_{SFT} , (shown below,) is set in parameter No. 1850, the reference position can be shifted.

Distance L_{DEC} , (shown below,) for the axis which reference position return was last performed is indicated on the diagnostic screen (No. 0302).

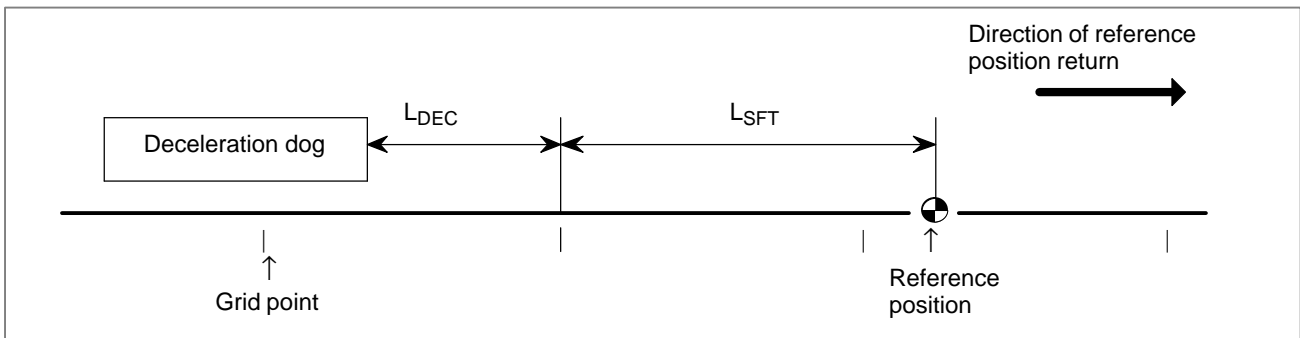

L_{SFT} : Reference position shift amount

L_{DEC} : Distance from the position where the deceleration dog is turned off to the first grid point (grid point when the shift amount is 0)

• How to adjust the reference position

(1) Set the SFD bit (bit 2 of parameter No. 1002) to 1, and set the reference position shift amount to 0. Then, perform reference position return.

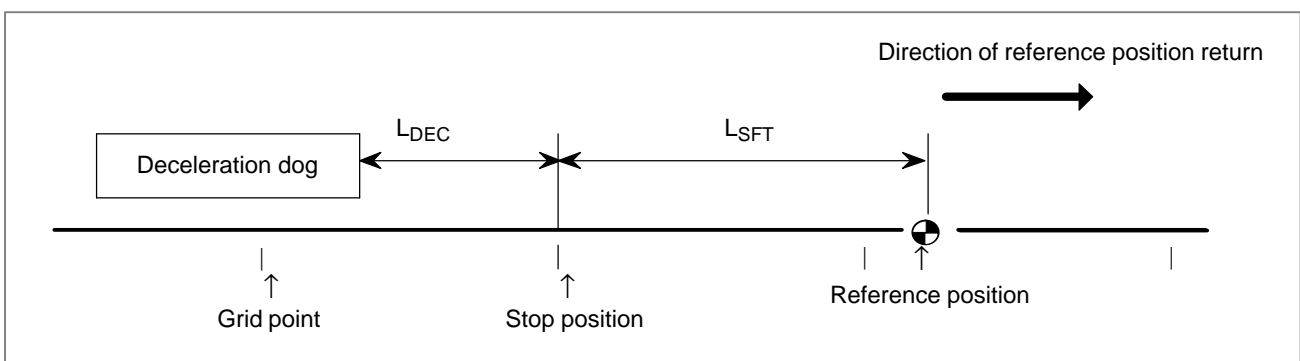

After the deceleration dog is turned off, the tool stops when the first grid point is reached. Distance L_{DEC} is indicated on the diagnostic screen (No. 0302).

(2) Determine the distance L_{SFT} (reference position shift amount) from the stop position to the reference position, and set it in parameter No. 1850.

This completes the adjustment of the reference position.

(3) Perform reference position return again. The tool stops when it reaches the reference position.

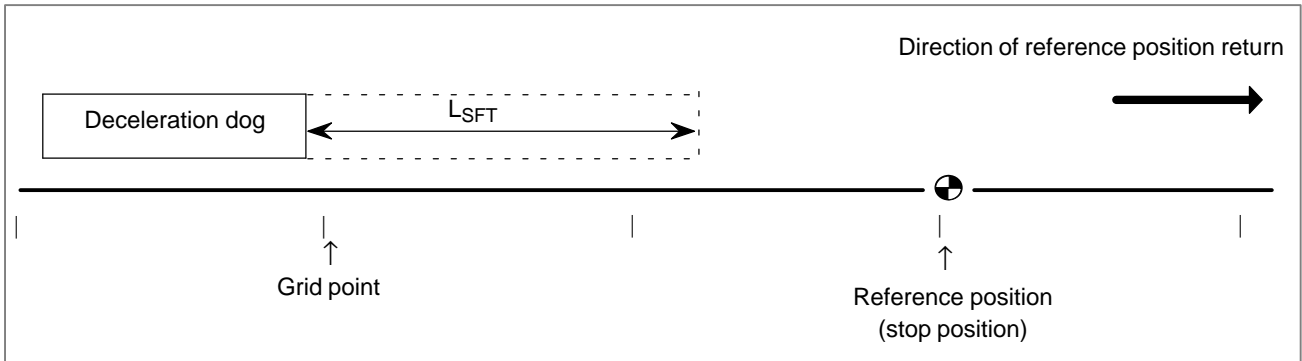

Parameter

	#7	#6	#5	#4	#3	#2	#1	#0
1002						SFD		

[Data type] Bit

SFD The function for shifting the reference position is

- 0 : Not used
- 1 : Used

1850	Reference position shift for each axis
------	--

[Data type] Two-word axis

[Unit of data] Detection unit

[Valid data range] -99999999 to 99999999

A reference position shift is set for each axis.

CAUTION

When bit 2 of parameter No. 1002, SFD, is set to 0, this parameter is used for reference position shift.

NOTE

When this parameter has been set, the power must be turned off before operation is continued.

Alarm and message

• Diagnostic display

0302

Distance from the position where the deceleration dog is turned off to the first grid point

[Data type] Two-word axis

[Unit of data] 0.001 mm (metric output), 0.0001 inch (inch output)

[Valid data range] -99999999 to 99999999

Note

NOTE

- 1 The reference position can be shifted only in the direction of reference position return.
- 2 When the SFD bit (bit 2 of parameter No. 1002) is 0, only the distance from the position where the deceleration dog is turned off to the first grid point (the grid point after grid shift) is indicated.

4.4 REFERENCE POSITION RETURN

General

The G28 command positions the tool to the reference position, via the specified intermediate point, then sets the completion signal for reference position return (see Section 4.1) to 1.

The reference position must be set in parameter No. 1240 (with the coordinates specified in the machine coordinate system,) before issuing the G28 command.

The tool moves to the intermediate point or reference position at the rapid traverse rate.

Parameter

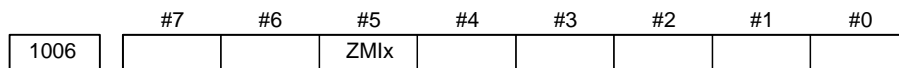

NOTE

After setting this parameter, turn the power off then on again so that the setting will take effect.

[Data type] Bit axis

ZMlx The direction of reference position return and the direction of initial backlash at power-on

0 : Positive direction

1 : Negative direction

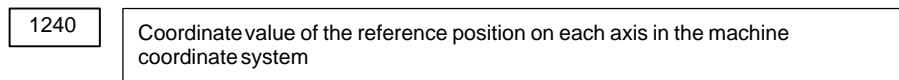

NOTE

After setting this parameter, turn the power off then on again so that the setting will take effect.

[Data type] Two-word axis

[Unit of data]	Increment system	IS-A	IS-B	IS-C	Unit
	Millimeter machine	0.01	0.001	0.0001	mm
	Inch machine	0.001	0.0001	0.00001	inch
	Rotation axis	0.01	0.001	0.0001	deg

[Valid data range] -99999999 to 99999999

Set the coordinate values of the reference positions in the machine coordinate system.

Alarm and message

Number	Message	Description
405	SERVO ALARM: (WRONG ZRN)	Position control system fault. Due to an CNC or servo system fault in the reference position return, there is a possibility that reference position return could not be executed correctly. Try the manual reference position return again.

Caution

CAUTION

- 1 The tool is moved from the intermediate point in a sequence similar to manual reference position return, if the G28 command is issued in the following cases:
 - When the reference position has not yet been established
 - When the input increment (millimeter/inch) is changed at a position other than the reference position
 In these cases, the tool leaves the intermediate point in the reference position return direction specified with bit 5 (ZMlx) of parameter No. 1006. The intermediate point must be specified at a position from which reference position return is possible.
- 2 If the G28 command is issued in the machine lock status, the completion signal for reference position return is not set to 1.
- 3 If millimeter input is selected for an inch-system machine, the completion signal for reference position return may be set to 1, even when the programmed tool position deviates from the reference position by the least input increment. This is because the least input increment is smaller than the least command increment for the machine.

Reference item

Series 16 <i>i</i> /18 <i>i</i> /160 <i>i</i> /180 <i>i</i> / 160 <i>is</i> /180 <i>is</i>	OPERATOR'S MANUAL (For Machining Center) (B-63534EN)	II.6	REFERENCE POSITION
	OPERATOR'S MANUAL (For Lathe) (B-63524EN)	II.6	REFERENCE POSITION
Series 21 <i>i</i> /210 <i>i</i> /210 <i>is</i>	OPERATOR'S MANUAL (For Machining Center) (B-63614EN)	II.6	REFERENCE POSITION
	OPERATOR'S MANUAL (For Lathe) (B-63604EN)	II.6	REFERENCE POSITION
Series 20 <i>i</i>	OPERATOR'S MANUAL (For Manual Milling Machine) (B-64204EN)	II.6	REFERENCE POSITION RETURN
	OPERATOR'S MANUAL (For Manual Lathes) (B-64194EN)	II.6	REFERENCE POSITION RETURN

4.5 2ND REFERENCE POSITION RETURN/3RD, 4TH REFERENCE POSITION RETURN

General

The G30 command positions the tool to the 2nd, 3rd, or 4th reference position, via the specified intermediate point. It then sets the completion signal for 2nd, 3rd, or 4th reference position return to 1.

Before issuing the G30 command, The 2nd, 3rd, or 4th reference position must be set in parameter No. 1241, 1242, or 1243 with coordinates in the machine coordinate system.

The tool moves to the intermediate point or 2nd, 3rd, or 4th reference position at the rapid traverse rate.

Return to the 2nd, 3rd, or 4th reference position can be performed only after the reference position has been established.

Signal

**Second reference
position return end
signals ZP21 to ZP 28
<F096>**

**Third reference position
return end signals ZP31
to ZP38 <F098>**

**Fourth reference
position return end
signals ZP41 to ZP48
<F100>**

[Classification] Output signal

[Function] The second, third, and fourth reference position end signals report the tool is at the second, third, and fourth reference positions on a controlled axis. These signals are provided for axes in a one-to-one correspondence. A numeric character appended to the end of a signal represents a controlled axis number, and a numeric character immediately following ZP represents a reference position number.

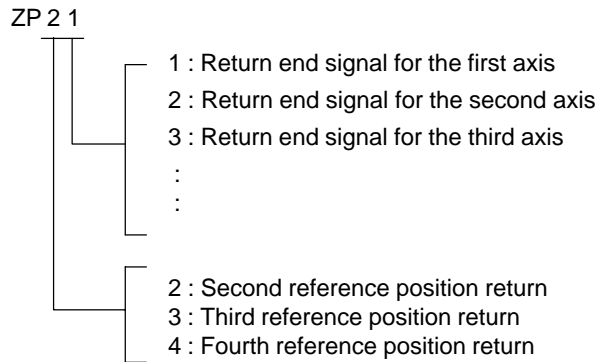

[Output condition] These signals turn to “1” when:

- The second, third, or fourth reference position return (G30) is completed, and the current position is in the in-position area.

These signals turn to “0” when:

- The tool moved from the reference position.
- An emergency stop is applied.
- A servo alarm is raised.

Signal address

	#7	#6	#5	#4	#3	#2	#1	#0
F096	ZP28	ZP27	ZP26	ZP25	ZP24	ZP23	ZP22	ZP21
F098	ZP38	ZP37	ZP36	ZP35	ZP34	ZP33	ZP32	ZP31
F100	ZP48	ZP47	ZP46	ZP45	ZP44	ZP43	ZP42	ZP41

Parameter

1241	Coordinate value of the second reference position on each axis in the machine coordinate system
1242	Coordinate value of the third reference position on each axis in the machine coordinate system
1243	Coordinate value of the fourth reference position on each axis in the machine coordinate system

[Data type] Two-word axis

[Unit of data]	Increment system	IS-A	IS-B	IS-C	Unit
	Millimeter machine	0.01	0.001	0.0001	mm
	Inch input	0.001	0.0001	0.00001	inch
	Rotation axis	0.01	0.001	0.0001	deg

[Valid data range] -99999999 to 99999999

Set the coordinate values of the second-fourth reference positions in the machine coordinate system.

Alarm and message

Number	Message	Description
046	ILLEGAL REFERENCE RETURN COMMAND	Other than P2, P3 and P4 are commanded for 2nd, 3rd and 4th reference position return command. Correct program.

Caution**CAUTION**

- 1 If the G30 command is issued in machine lock status, the completion signal for 2nd, 3rd, or 4th reference position return is not set to 1.
- 2 If millimeter input is selected for an inch-system machine, the completion signal for 2nd, 3rd, or 4th reference position return may be set to 1, even when the programmed tool position deviates from the 2nd, 3rd, or 4th reference position by the least input increment. This is because the least input increment is smaller than the least command increment for the machine.

Reference item

Series 16i/18i/160i/180i/ 160is/180is	OPERATOR'S MANUAL (For Machining Center) (B-63534EN)	II.6	REFERENCE POSITION
	OPERATOR'S MANUAL (For Lathe) (B-63524EN)	II.6	REFERENCE POSITION
Series 21i/210i/210is	OPERATOR'S MANUAL (For Machining Center) (B-63614EN)	II.6	REFERENCE POSITION
	OPERATOR'S MANUAL (For Lathe) (B-63604EN)	II.6	REFERENCE POSITION
Series 20i	OPERATOR'S MANUAL (For Manual Milling Machine) (B-64204EN)	II.6	REFERENCE POSITION RETURN
	OPERATOR'S MANUAL (For Manual Lathes) (B-64194EN)	II.6	REFERENCE POSITION RETURN

4.6 FLOATING REFERENCE POSITION RETURN

General

It is possible to return the tool to the floating reference position by commanding the G30.1.

The floating reference position is located on the machine and can be a reference position for some sort of machine operation. It is not always a fixed position and may vary in some cases. The floating reference position can be set using the soft keys of MDI and can be memorized even after power is turned off.

Generally, the position where the tools can be changed on machining center or milling machine is at a set position, the tools cannot be replaced at any just position. Normally the tool change position can be at any of the No. 1 to No. 4 reference positions. The tool can be moved to these positions easily by G28 or G30 command. However, depending on the machine, the tools can be replaced at any position as long as it does not contact the workpiece.

In lathes, the tool can generally be changed at any position unless it touches the workpiece or tailstock.

For machinery such as these, in order to reduce the cycle time, it is advantageous to replace tools at a position as close as possible to the workpiece. For this purpose, change position should be moved for each workpiece which this feature can be easily performed. The tool change position which is suitable for workpieces can be memorized as the floating reference position and it is possible to return to the tool change position by commanding the G30.1.

When the G30.1 is commanded, the axis goes to the specified intermediate position at first and then goes to the floating reference position from the intermediate point. The positioning to the intermediate position or to the floating reference position is performed at rapid traverse for each axis (non-linear positioning). The floating reference position return completion signal turns to "1" after completing the floating reference position return.

Signal

Floating reference position return end signal FRP1 to FRP8 <F116>

[Classification] Output signal

[Function] Notify the system that the tool is at the floating reference position on a controlled axis.

A floating reference position return end signal is provided for each axis. The number appended to each signal name indicates the number of the controlled axis.

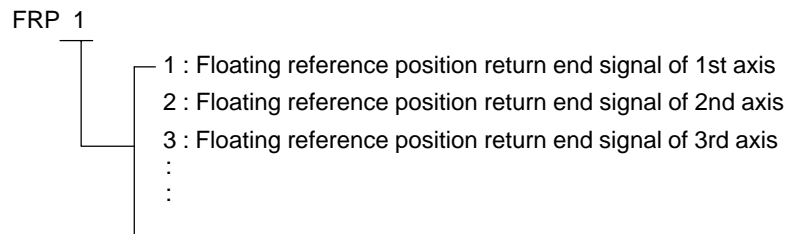

[Output condition] The signals are set to 1 in the following case:

- When the tool is positioned to within the in-position area after floating reference position return (G30.1)

These signals are set to “0” when:

- The tool is moved from the floating reference position
- An emergency stop is applied.
- A servo alarm is raised.

Signal address

	#7	#6	#5	#4	#3	#2	#1	#0
F116	FRP8	FRP7	FRP6	FRP5	FRP4	FRP3	FRP2	FRP1

Parameter

	#7	#6	#5	#4	#3	#2	#1	#0
1201					FPC			

[Data type] Bit

FPC When the floating reference position is specified using soft keys on the current position display screen

0 : The value of the displayed relative position is not preset. (In other words, the value does not change.)

1 : The value of the displayed relative position is preset to 0.

1244	Coordinates of the floating reference position for each axis
------	--

[Data type] Two-word axis

[Unit of data]	Increment system	IS-A	IS-B	IS-C	Unit
	Millimeter machine	0.01	0.001	0.0001	mm
	Inch input	0.001	0.0001	0.00001	inch
	Rotation axis	0.01	0.001	0.0001	deg

[Valid data range] -99999999 to 99999999

This parameter specifies the coordinates of the floating reference position for each axis. The parameter is automatically set when the floating reference position is specified using soft keys on the current position display screen.

Reference Item

Series 16i/18i/160i/180i/ 160is/180is	OPERATOR'S MANUAL (For Machining Center) (B-63534EN)	II.6.2	FLOATING REFERENCE POSITION RETURN (G30.1)
		III.11.1.7	Setting the Floating Reference Position
	OPERATOR'S MANUAL (For Lathe) (B-63524EN)	II.6.2	FLOATING REFERENCE POSITION RETURN (G30.1)
		III.11.1.7	Setting the Floating Reference Position

4.7 BUTT-TYPE REFERENCE POSITION SETTING

General

This function automates the procedure of butting the tool against a mechanical stopper on an axis to set a reference position. The purpose of this function is to eliminate the variations in reference position setting that arise depending on the operator, and to minimize work required to make fine adjustments after reference position setting.

Select the axis for which the reference position is to be set, then perform cycle start. Then, the following operations are performed automatically:

1. The torque (force) of the selected axis is reduced to make the butting feedrate constant, and the tool is butted against the mechanical stopper. Then, the tool is withdrawn a parameter-set distance from the mechanical stopper.
2. Again, the torque (force) of the selected axis is reduced, and the tool is butted against the mechanical stopper. Then, the tool is withdrawn a parameter-set distance from the mechanical stopper.
3. The withdrawal point on the axis is set as the reference position.

Basic procedure for butt-type reference position setting

- (1) First, set the parameters required for butt-type reference position setting.

ZMIx, bit 5 of parameter (No. 1006):	Direction of reference position setting
Parameter No. 7181:	Withdrawal distance
Parameter No. 7182:	Reference position setting distance
Parameter No. 7183:	Butting feedrate 1
Parameter No. 7184:	Butting feedrate 2
Parameter No. 7185:	Withdrawal feedrate in reference position setting
Parameter No. 7186:	Torque limit

- (2) Select manual reference position return mode.
- (3) By using a manual handle feed axis select signal, select the axis on which the reference position is to be set.
- (4) Perform cycle start.
This starts the cycle operation for reference position setting.
- (5) During the cycle operation, the automatic operation start signal OP is 1.

Cycle operation

When no reference position has been set (APZx, bit 4 of parameter No. 1815, is 0), operations (A) to (E), below, are performed automatically to set a reference position.

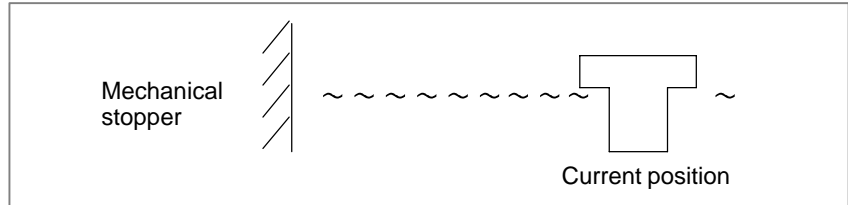

(A) The tool is moved along a specified axis with a limited torque until it butts against the mechanical stopper.

The tool is moved in the direction specified with ZMIx (bit 5 of parameter No. 1006), at the feedrate specified with parameter No. 7183, at the torque specified with parameter No. 7186 (until the tool strikes the mechanical stopper).

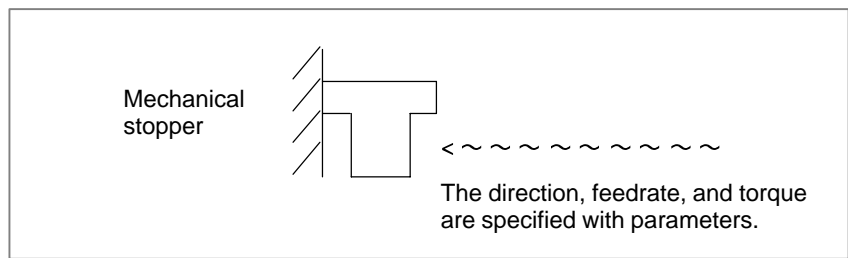

(B) After the tool strikes the mechanical stopper, the tool is withdrawn in the direction opposite to the butting direction, along the axis for a parameter-set distance.

The tool is moved in the direction opposite to that specified with ZMIx (bit 5 of parameter No. 1006), at the feedrate specified with parameter No. 7185, for the distance specified with parameter No. 7181.

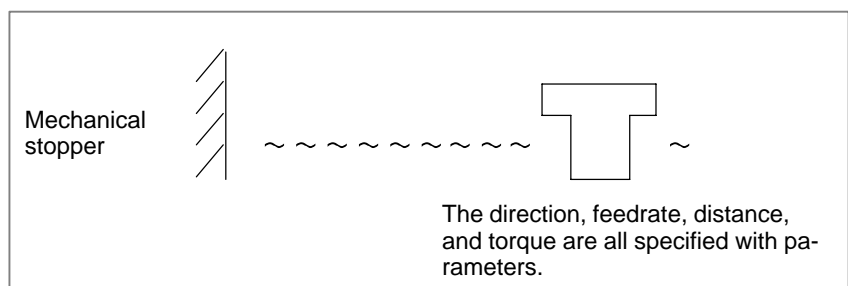

(C) Operations (D) and (E) are performed from the withdrawal point, such that the tool is butted against the mechanical stopper at a constant feedrate in reference position setting.

(D) The tool moves along the specified axis at a specified torque until it butts against the mechanical stopper.

The tool moves in the direction specified with ZMIx (bit 5 of parameter No. 1006), at the feedrate specified with parameter No. 7184, at the torque specified with parameter No. 7186 (until the tool strikes the mechanical stopper).

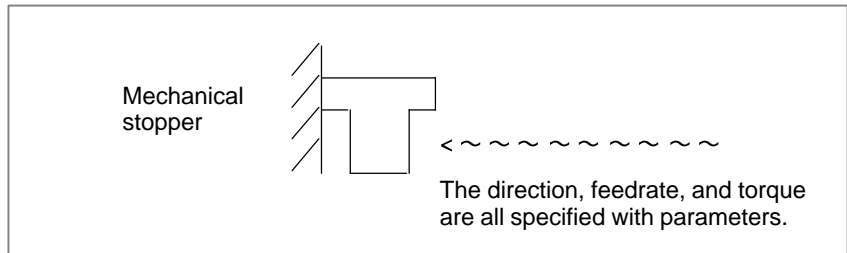

(E)After the tool strikes the mechanical stopper end on the axis, the tool is withdrawn in the direction opposite to the butting direction, along the axis for a parameter-set distance.

The tool is moved in the direction opposite to that specified with ZMIx (bit 5 of parameter No. 1006), at the feedrate specified with parameter No. 7185, for the distance specified with parameter No. 7182.

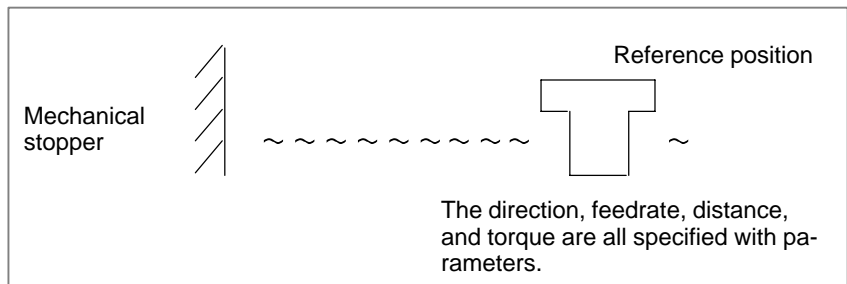

For parameter Nos. 7183 and 7184, set the feedrates at which the tool is moved toward the mechanical stopper with a limited torque, considering the machine accuracy.

After the tool strikes the mechanical stopper, and the tool is withdrawn the distance specified with parameter No. 7182, the withdrawal point is set as the reference position on the specified axis. Then, the reference position return end signal and reference position establishment signal are set to 1.

After reference position return has been completed, alarm PS000 is issued. Turn the power off then back on before continuing operation.

After the reference position is set

When the reference position has already been set (when APZx, bit 4 of parameter No. 1815, is 1), performing butt-type reference position setting causes the tool to be positioned to the reference position at the rapid traverse rate without the cycle operation. Upon the completion of positioning, the reference position return end signal is set to 1.

The timing chart for the cycle operation is shown below.

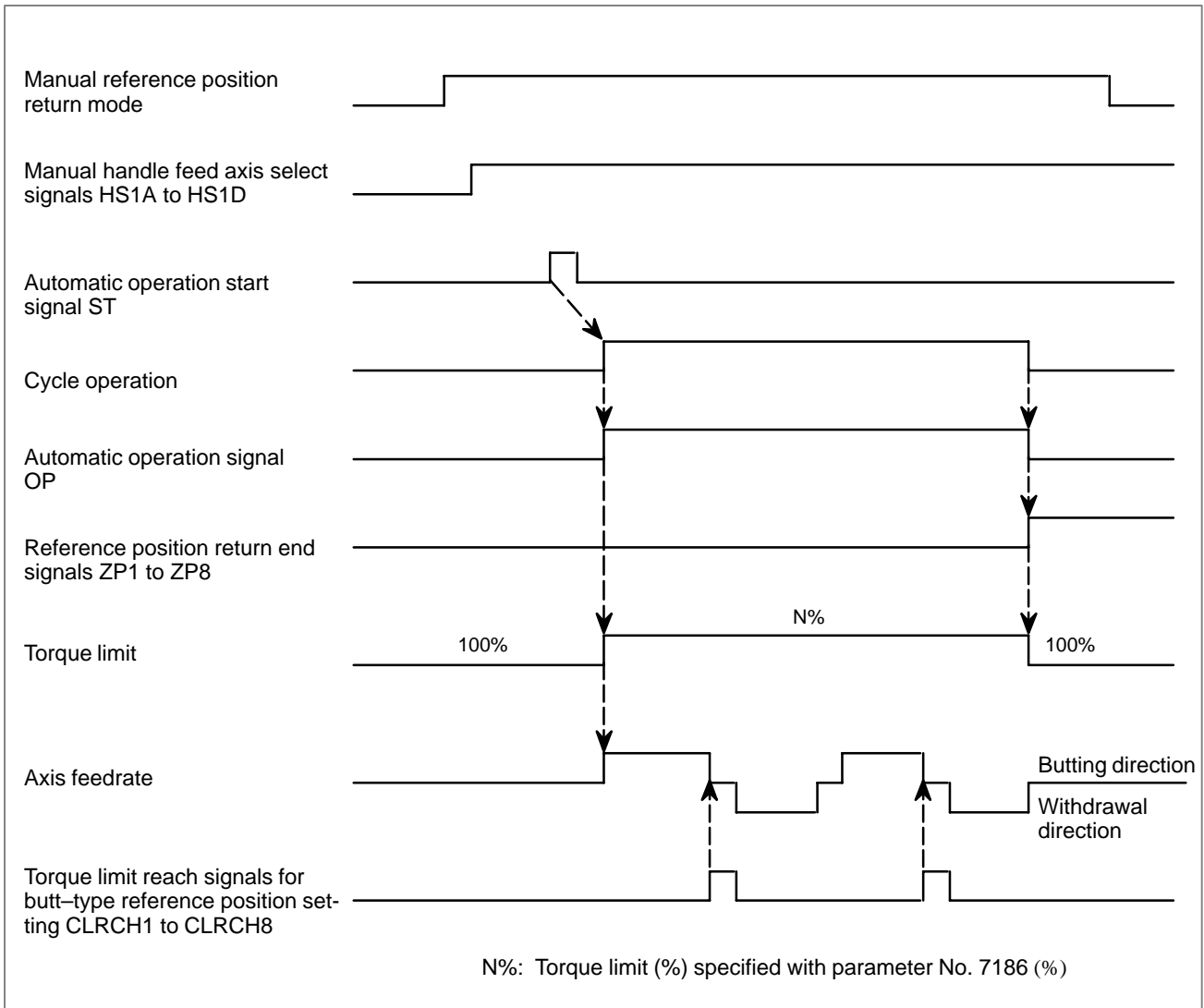

Signal

Torque limit reach signals for butt-type reference position setting CLRCH1 to CLRCH8 <F180>

[Classification] Output signal

[Function] These signals are used to post notification of the torque limit having been reached for each corresponding axis during cycle operation for butt-type reference position setting.

[Operation] Each signal is set to 1 when:

- The torque limit is reached for the corresponding axis during cycle operation for butt-type reference position setting.

Each signal is set to 0 when:

- The torque limit is not reached for the corresponding axis during cycle operation for butt-type reference position setting.

Signal address

	#7	#6	#5	#4	#3	#2	#1	#0
F180	CLRCH8	CLRCH7	CLRCH6	CLRCH5	CLRCH4	CLRCH3	CLRCH2	CLRCH1

Parameter

	#7	#6	#5	#4	#3	#2	#1	#0
1006			ZMlx					

NOTE

When this parameter is changed, turn off the power before continuing operation.

[Data type] Bit axis

ZMlx The direction of reference position return and the direction of initial backlash at power-on.

0 : Positive direction

1 : Negative direction

7181	First withdrawal distance in butt-type reference position setting
------	---

[Data type] 2-word axis

[Unit of data]	Increment system	IS-A	IS-B	IS-C	Unit
	Millimeter machine	0.01	0.001	0.0001	mm
	Inch machine	0.001	0.0001	0.00001	inch

[Valid data range] –99999999 to 99999999

When the butt-type reference position setting function is used, this parameter sets a distance on an axis, along which withdrawal is performed after the mechanical stopper is hit (distance from the mechanical stopper to the withdrawal point).

NOTE

Set the same direction as the direction set for ZMlx, bit 5 of parameter No. 1006. If the opposite direction is set, the cycle operation will not start.

7182

Second withdrawal distance in butt-type reference position setting

[Data type] 2-word axis

[Unit of data]

Increment system	IS-A	IS-B	IS-C	Unit
Millimeter machine	0.01	0.001	0.0001	mm
Inch machine	0.001	0.0001	0.00001	inch

[Valid data range] –99999999 to 99999999

When the butt-type reference position setting function is used, this parameter sets a distance on an axis, along which withdrawal is performed after the mechanical stopper is hit (distance from the mechanical stopper to the withdrawal point).

NOTE

Set the same direction as the direction set for ZMlx, bit 5 of parameter No. 1006. If the opposite direction is set, the cycle operation will not start.

7183

First butting feedrate in butt-type reference position setting

[Data type] Word axis

[Unit of data]

[Valid data range]

Increment system	Unit of data	Valid data range	
		IS-A, IS-B	IS-C
Millimeter machine	1 mm/min	30–15000	30–12000
Inch machine	0.1 inch/min	30–6000	30–4800

When the butt-type reference position setting function is used, this parameter sets the feedrate first used to hit the stopper on an axis.

7184

Second butting feedrate in butt-type reference position setting

[Data type] Word axis

[Unit of data]

[Valid data range]

Increment system	Unit of data	Valid data range	
		IS-A, IS-B	IS-C
Millimeter machine	1 mm/min	30–15000	30–12000
Inch machine	0.1 inch/min	30–6000	30–4800

When the butt-type reference position setting function is used, this parameter sets the feedrate used to hit the stopper on an axis for a second time.

7185	Withdrawal feedrate (common to the first and second butting operations) in butt-type reference position setting)
------	--

[Data type] Word axis

[Unit of data] [Valid data range]	Increment system	Unit of data	Valid data range	
			IS-A, IS-B	IS-C
	Millimeter machine	1 mm/min	30-15000	30-12000
	Inch machine	0.1 inch/min	30-6000	30-4800

When the butt-type reference position setting function is used, this parameter sets the feedrate used for withdrawal along an axis after the mechanical stopper has been hit.

7186	Torque limit value in butt-type reference position setting
------	--

[Data type] Byte axes

[Unit of data] %

[Valid data range] 0 to 100

This parameter sets a torque limit value in butt-type reference position setting.

NOTE

When 0 is set in this parameter, 100% is assumed.

Alarm and message

Number	Message	Contents
000	PLEASE TURN OFF POWER	A parameter which requires the power off was input, turn off power.

Note

NOTE

This function is supported only when an absolute-position detector is installed.

**4.8
LINEAR SCALE I/F
WITH ABSOLUTE
ADDRESS
REFERENCED MARK
(A/B PHASE)/LINEAR
SCALE WITH
DISTANCE-CODED
REFERENCE MARKS
(SERIAL)**

Outline

By using optional function "Linear scale I/F with absolute address referenced mark", we can use "Linear scale I/F with absolute address referenced mark (A/B phase)", and "Linear scale with distance-coded reference marks (serial)"

Linear scale I/F with absolute address referenced mark (A/B phase)

The interval of each reference marks of linear scale I/F with absolute address referenced mark (A/B phase) are variable. Accordingly, if the interval is determined, the absolute position can be determined. The CNC measures the interval of reference marks by axis moving of short distance and determines the absolute position. Consequently the reference position can be established without moving to reference position.

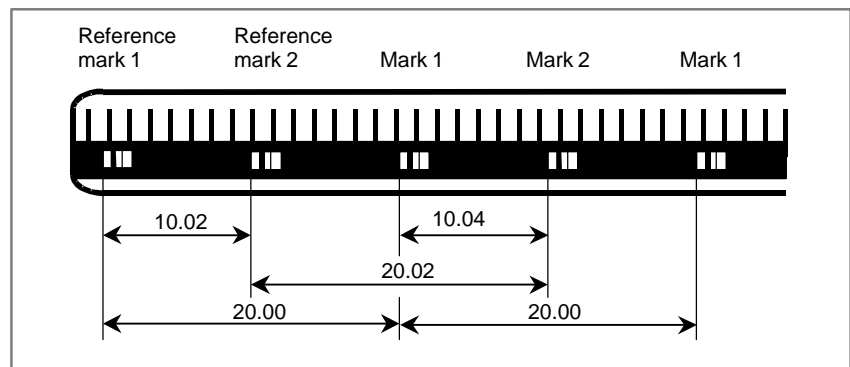
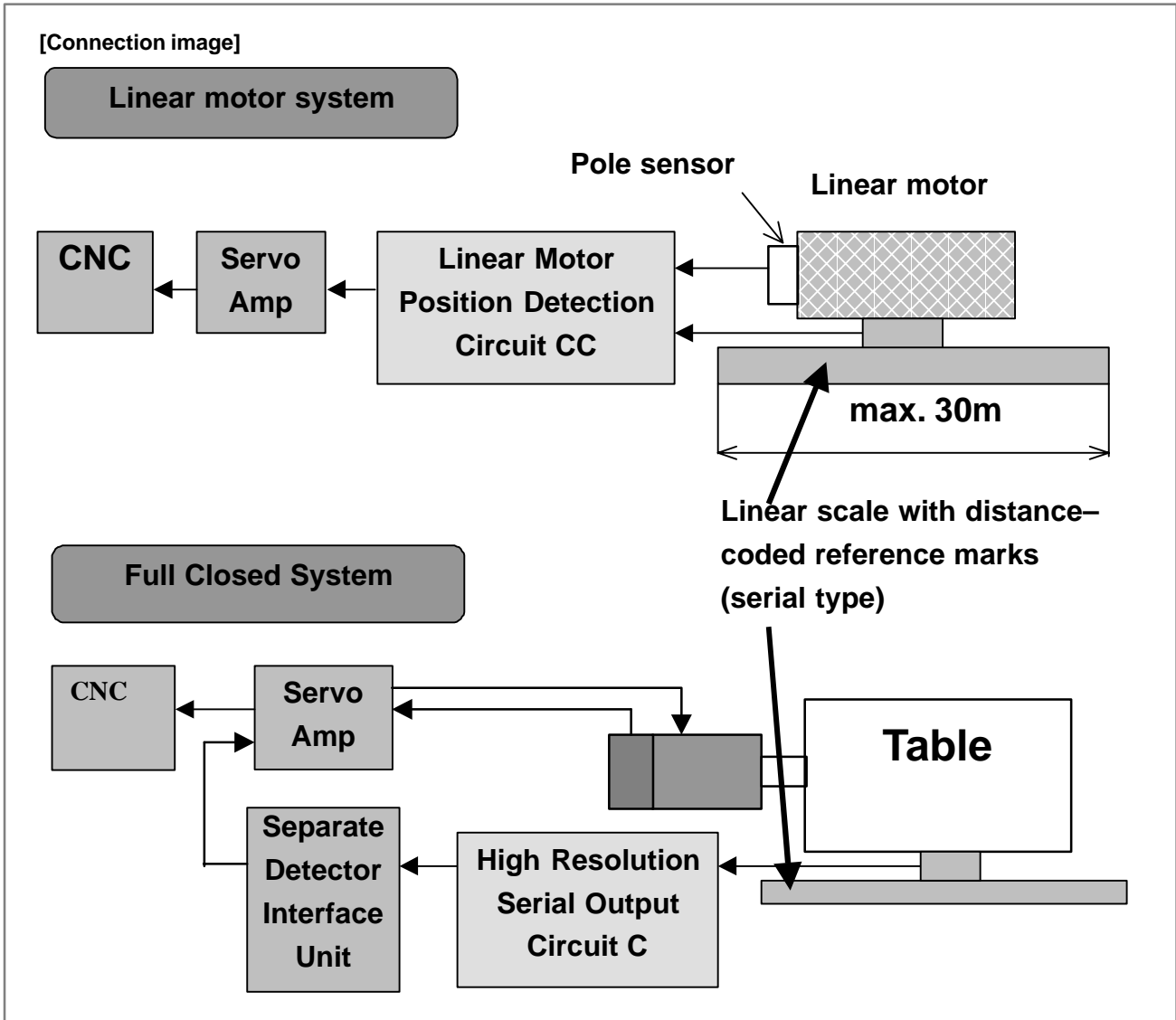

Fig. 4.8(a) Example of linear scale I/F with absolute address referenced mark (A/B phase)

Linear scale with distance-coded reference marks (serial)

The basic structure of Linear scale with distance-coded reference marks (serial) is same as A/B-phase scale (Linear scale with absolute address referenced mark). But this scale differs from A/B-phase in point of circuit. High-resolution serial output circuit is used. This serial output signal enables high-speed high-precision detection. Both linear motor system and full closed system are available.



Specifications (linear scale I/F with absolute address referenced mark (A/B phase))

Procedure for reference position establishment

- (1) Select the JOG mode, and set the manual reference position return selection signal ZRN to "1".
- (2) Set a direction selection signal(+J1,-J1,+J2,-J2,...) for a target axis.
- (3) The axis is fed at a constant low speed (reference position return FL feedrate specified by parameter (No.1425) setting).
- (4) When a reference mark is detected, the axis stops, then the axis is fed at a constant low speed again.
- (5) Above (4) is executed repeatedly until two or three or four reference marks are detected. And absolute position is determined and reference position establishment signal (ZRF1,ZRF2,ZRF3,+ _...) turns to "1".
The number of reference marks to be detected is defined by parameter No.1802.

The axis does not stop and reference position establishment is proceeded even if the feed axis direction selection signal (+J1,-J1,+J2,-J2,...) turns to "0" between step (2) and (5).

The timing chart for this procedures is given below.

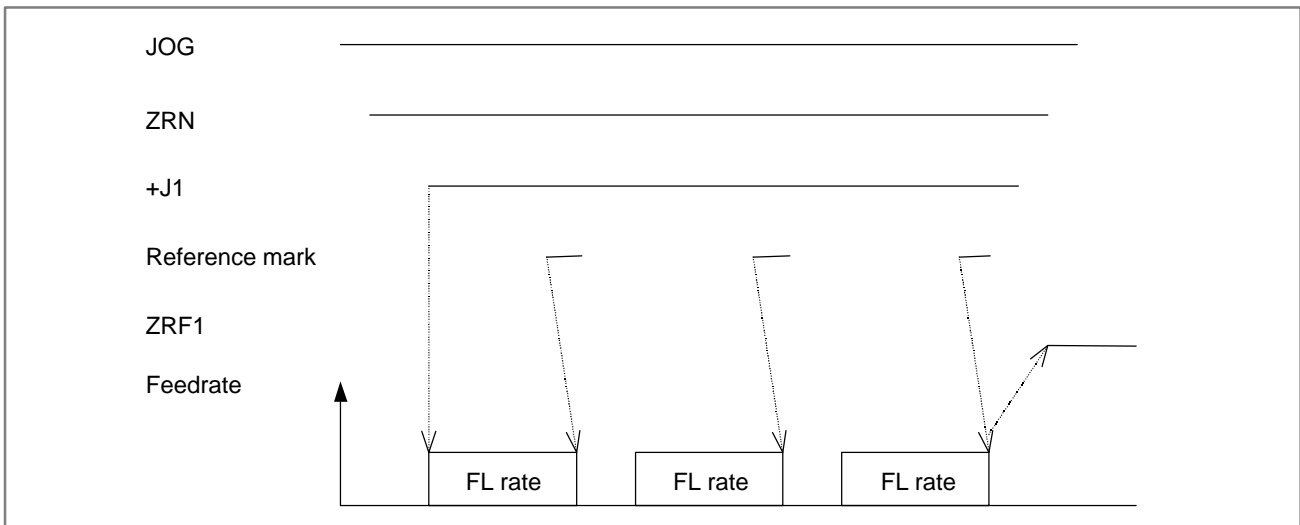

Fig. 4.8(b) Timing chart for reference position establishment

Simple synchronous axis

The function is available for only FS16i/18i/21i-MB,18i-MB5.

When the function is applied for simple synchronous axis, the following condition should be kept.

- (1) Linear scale I/F with absolute address referenced mark (A/B phase) with the same reference marks at intervals should be applied for the master axis and the slave axis.
- (2) The master axis scale and the slave axis scale should be installed in parallel direction. (The zero positions should be faced the same direction.)
- (3) To the parameters, which relates to this function (except No.1883, No.1884), the same value must be set for the master axis and for the slave axis.
- (4) During operating the establishment of reference position, the state of selecting the manual feed axis for simple synchronous control signals (SYNCJn<G0140>) should be kept.

Procedure for Reference Position Establishment by synchronous axis is as follows.

- When either reference mark of the master axis or the slave axis is detected, the both axes stop. And the both axes are fed again at a Reference Position Return FL Feedrate.
- The above mentioned operations are repeated until the master axis and the slave axis detect enough (3 or 4) reference marks.
- Absolute position of both axes are calculated and Reference Position Establishment Signal (ZRF1,ZRF2,...) turns to "1".

(Example of 3 points measurement system)

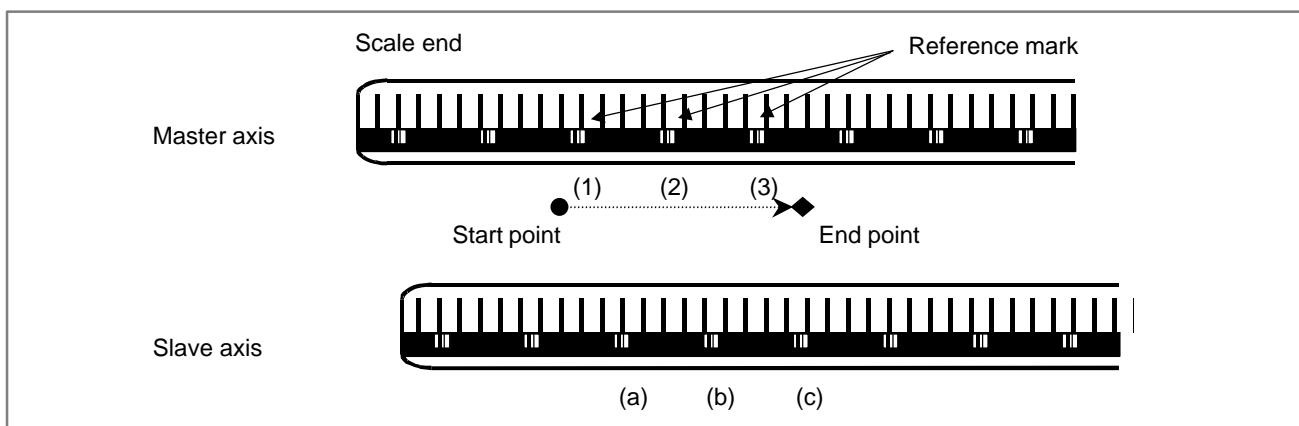

In the above example, the following sequence is executed.

- a. When the reference mark (1) of the master axis is detected, both master axis and slave axis stop.
- b. Both the axes begin to move again at a Reference Position Return FL feedrate.
- c. When the reference mark (a) of the slave axis is detected, both axes stop again.
- d. Both the axes begin to move again at FL feedrate.
- e. Both axes repeat the operation until all point ((2) → (b) → (3) → (c)) are detected.
- f. When the slave axis detects the third reference mark (c), both the axes end the Reference Position Establishment.

[Synchronization]

By setting bit 7 (for one simple synchronization pair) of parameter No. 8301 for synchronization or bit 7 (for multiple simple synchronization pairs) of parameter No. 8303 to 1, compensation pulses are output to the slave axis at reference position establishment time to match the machine position with the master axis. Thus, an error between the master axis and slave axis can be corrected automatically.

NOTE

- 1 When a synchronization error is greater than the value of parameter No. 8315 (for one simple synchronization pair) or the value of parameter No. 8325 (for multiple simple synchronization pairs), servo alarm 407 is issued. Servo alarm 407 can be reset by using the reset key. In this case, however, the slave position remains to be shifted. So, perform slave positioning.
- 2 When a slave alarm is reset, synchronization is not performed.
- 3 In the case of multiple simple synchronization pairs, set bit 7 (axis-by-axis parameter) of parameter No. 8303 for the master axis.

Reference position return

- (1) When the reference position is not established and the axis moved by turning the feed axis direction signal (+J1,-J1,+J2,-J2,...) to "1" in REF mode, the reference position establishment procedure is executed.
- (2) When the reference position is already established and the axis is moved by turning the feed axis direction signal (+J1,-J1,+J2,-J2,...) to "1" in REF mode, the axis is moved to the reference point without executing the reference position establishment procedure.
- (3) When the reference position is not established and the reference position return command (G28) is executed, the reference position establishment procedure is executed. The next movement the axis depends on the setting of PRM No.1818#0(RFS).
- (4) When the reference position is already established and the reference position command (G28) is executed, the movement of the axis depends on the setting of PRM No.1818#1(RF2).

Note

- (1) In the following case, P/S090 alarm occurs.
 - (a) The actual interval of reference marks is different from parameter setting value.
- (2) In this procedure, the axis does not stop until three or four reference marks are detected. If this procedure is started at the position near the scale end, CNC can not detect three or four reference marks and the axis does not stop until over travel alarm occurs. Please care to start at the position that has enough distance from scale end.

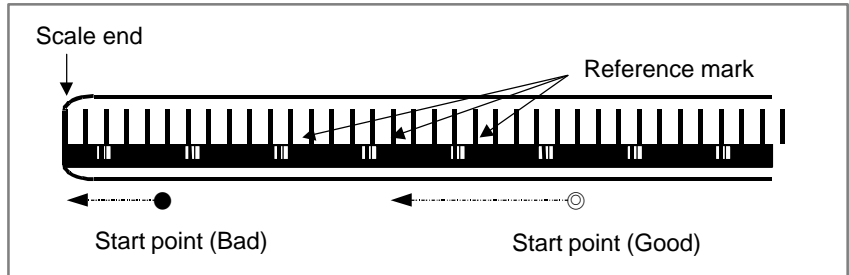

- (3) In the following cases, this function does not perform.
 - (a) Parameter No.1821(mark1 interval) or No.1882(mark2 interval) is "0".
 - (b) The setting value of parameter No.1821 and No.1882 are the same.
 - (c) Parameter No.1821 value \geq No.1882 value*2
or No.1882 value \geq No.1821 value*2
- (4) Rotary encoder with absolute address referenced mark (A/B phase)
 - (a) When the rotary encoder with absolute address referenced mark (A/B phase) is used, please set a parameter No.1815#3 (DCR) to "1".

In case of rotary encoder with absolute address referenced mark (A/B phase), the marker interval may be different from parameter setting value. (a-b section of the following figure) When the reference point return is executed through this section, it is not able to establish the reference point. Therefore, in case of rotary encoder with absolute address referenced mark (A/B phase), if the reference point return is started for B point from A point of below figure, the reference point is not established yet at B point. The reference point return is re-started for C point. The reference point return procedure is finished at C point.

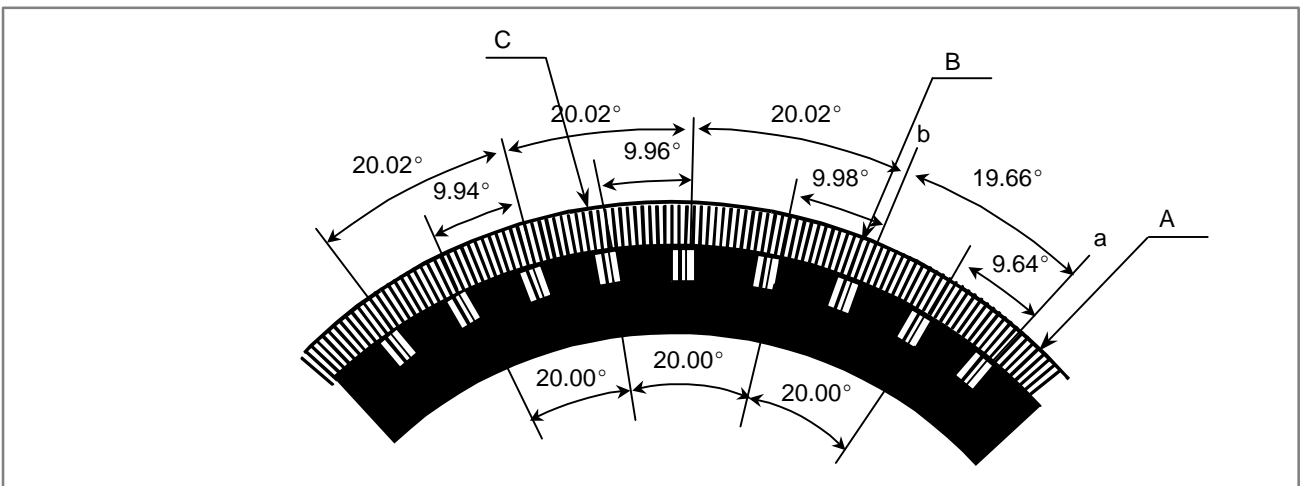

- (b) When the reference point return procedure is executed, the coordinate value are rounded in 0 to 360 degree, even if a parameter No. 1006#1(ROS) is set to "1" (Machine coordinate values are linear axis type).
 - (c) In case of rotary encoder with absolute address referenced mark (A/B phase), only the measurement by three points or four points is possible. (parameter 1802#2(DC2) is disregarded)
- (5) A difference of parameter No.1821 and No.1882 must be more than 4.

Example)

When the scale, which is that mark1 interval is 20.000mm and mark2 interval is 20.004mm, is used on IS-B machine :

When the detection unit of 0.001mm is selected, parameter No.1821 and No.1882 must be set "20000" and "20004", and the difference of them is "4".

To use such a scale, please adjust the detection unit by modification of parameter No.1820(CMR) and No.2084/2085(flexible feed gear) to make the difference of No.1821 and 1882 more than 4 as following examples.

- (a) Set the detection unit=0.0001mm, and set No.1821=200000, No.1882=200040
- (b) Set the detection unit=0.0005mm, and set No.1821=40000, No.1882=40008

NOTE

When the detection unit is changed, all of parameters which are concerned with the detection unit (e.g. in-position width, positioning deviation limit, etc.) must be changed.

- (6) There are the following limitations when the angular axis control is used.
- (a) It is necessary to use the linear scale I/F with absolute address referenced mark (A/B phase) for both the perpendicular axis and the angular axis.
 - (b) When the reference point of the perpendicular axis is established, it is necessary to establish the reference point of the angular axis previously. When the reference point of the angular axis is not previously established, the P/S090 alarm is generated.
 - (c) During the reference point establishment operation of the angular axis, the command in the perpendicular axis is invalid in the manual reference point return.
- (7) Measurement of two point (parameter No.1802#2(DC2)=1)
- (a) Please set the direction of the scale zero point in the parameter (No.1817#4 (SCP)) correctly at two point measurement. Because an incorrect coordinate system will be established when a wrong value is set in parameter SCP. It is very dangerous. In this case, please execute reference point return again after setting the correct value in parameter SCP.

- (b) Because an incorrect value is set in parameter No.1883 and 1884 when setting parameter SCP is incorrect when the automatic setting of parameter No.1883 and 1884 was executed. It is very dangerous. In this case, please execute automatic setting of parameter No.1883 and 1884 again after setting the correct value in parameter SCP.

Specifications (linear scale with distance-coded reference marks (serial))

Procedure for reference position establishment

- (1) Select the JOG mode, and set the manual reference position return selection signal ZRN to "1".
- (2) Set a direction selection signal(+J1,-J1,+J2,-J2,...) for a target axis.
- (3) The axis is fed at a constant low speed (reference position return FL feedrate specified by parameter (No.1425) setting).
- (4) When the absolute position of linear scale with distance-coded reference marks (serial) is detected, the axis stops. Then the absolute position of CNC is calculated and reference position establishment signal (ZRF1,ZRF2,ZRF3,+ ...) turns to "1".

The axis does not stop and reference position establishment is proceeded even if the feed axis direction selection signal (+J1,-J1,+J2,-J2,...) turns to "0" between step (2) and (4).

The timing chart for this procedures is given below.

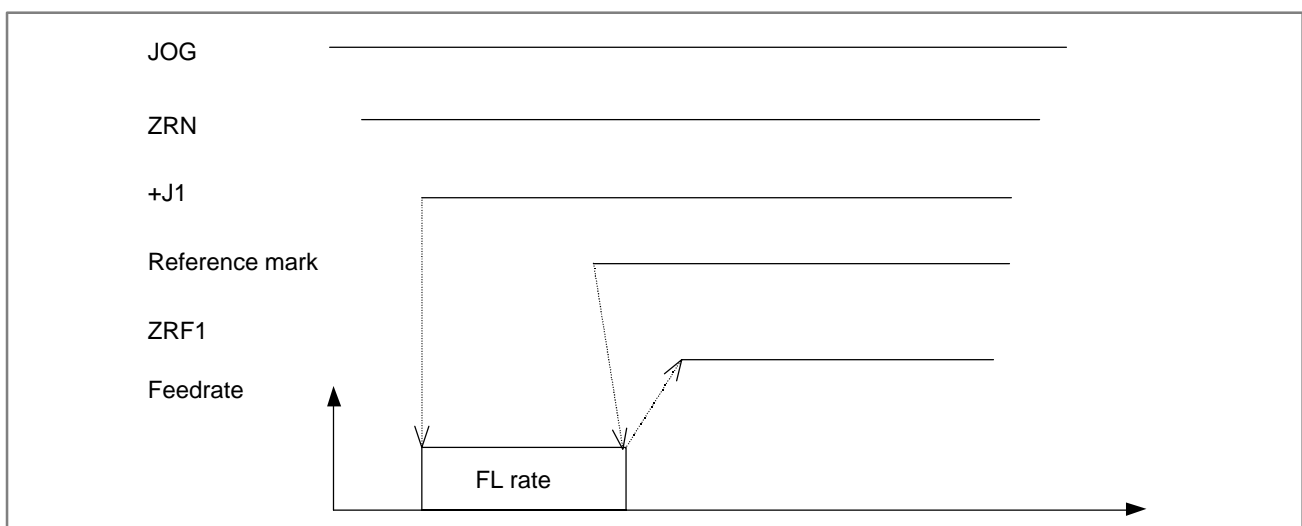

Fig. 4.8(c) Timing chart for reference position establishment

Simple synchronous axis

The function is available for only FS16i/18i/21i-MB,18i-MB5.

When the function is applied for simple synchronous axis, the following condition should be kept.

- (1) Linear scale with distance-coded reference marks (serial) with the same reference marks at intervals should be applied for the master axis and the slave axis. The mixture of linear-motor system and full-closed system is unavailable between the master axis and the slave axis.
If either of the master axis or the slave axis is not the linear scale with distance-coded reference marks, P/S 5327 occurs when reference position establishment is tried with the signal of selecting the manual feed axis for simple synchronized control (SYNCJn<G0140>) to '1'.
- (2) The master axis scale and the slave axis scale should be installed in parallel direction. (The zero positions should be faced the same direction.)
- (3) To the parameters, which relate to this function (except No.1883, No.1884), the same value must be set for the master axis and for the slave axis.
- (4) During operating the establishment of reference position, the state of selecting the manual feed axis for simple synchronized control signal(SYNCJn<G0140>) should be kept.

Procedure for Reference Position Establishment by synchronous axis is as follows.

- Both of axes (master axis and slave axis) are fed on the reference position return FL feedrate until distance coded scales of both axes detect the absolute position.
- Then absolute position of both axes are calculated and Reference Position Establishment Signals (ZRF1,ZRF2,...) turn to "1".

[Synchronization]

By setting bit 7 (for one simple synchronization pair) of parameter No. 8301 for synchronization or bit 7 (for multiple simple synchronization pairs) of parameter No. 8303 to 1, compensation pulses are output to the slave axis at reference position establishment time to match the machine position with the master axis. Thus, an error between the master axis and slave axis can be corrected automatically.

NOTE

- 1 When a synchronization error is greater than the value of parameter No. 8315 (for one simple synchronization pair) or the value of parameter No. 8325 (for multiple simple synchronization pairs), servo alarm 407 is issued. Servo alarm 407 can be reset by using the reset key. In this case, however, the slave position remains to be shifted. So, perform slave positioning.
- 2 When a slave alarm is reset, synchronization is not performed.
- 3 In the case of multiple simple synchronization pairs, set bit 7 (axis-by-axis parameter) of parameter No. 8303 for the master axis.

Reference position return

- (1) When the reference position is not established and the axis moved by turning the feed axis direction signal (+J1,-J1,+J2,-J2,...) to "1" in REF mode, the reference position establishment procedure is executed.
- (2) When the reference position is already established and the axis is moved by turning the feed axis direction signal (+J1,-J1,+J2,-J2,...) to "1" in REF mode, the axis is moved to the reference point without executing the reference position establishment procedure.
- (3) When the reference position is not established and the reference position return command (G28) is executed, the reference position establishment procedure is executed. The next movement the axis depends on the setting of PRM No.1818#0(RFS).
- (4) When the reference position is already established and the reference position command (G28) is executed, the movement of the axis depends on the setting of PRM No.1818#1(RF2).

Note

- (1) When the Linear scale with distance-coded reference marks (serial) is used, please don't forget to set parameter No.1818#3(NSD) to 1. And distance coded rotary encoder (serial type) is unavailable.
- (2) On the Linear scale with distance-coded reference marks (serial), the axis does not stop until three reference marks are detected. If this procedure is started at the position near the scale end, CNC can not detect three reference marks and the axis does not stop until over travel alarm occurs. Please care to start at the position that has enough distance from scale end.
And if establishment of reference position is failed, the establishment is retried. Then axis does not stop until still more three reference marks are detected. So please set the maximum move amount (detection unit: Prm. No.14010) not to reach the scale end.

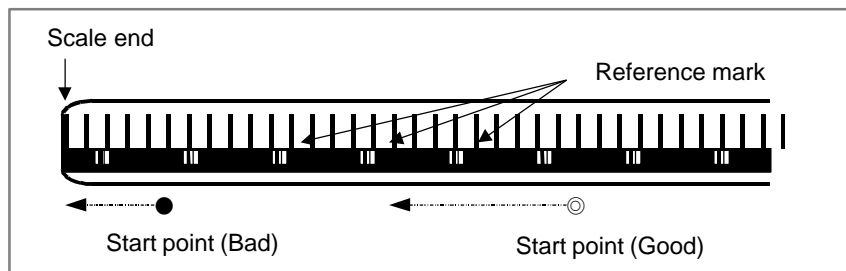

- (3) There are the following limitations when the angular axis control is used.
 - (a) It is necessary to use the Linear scale with distance-coded reference marks (serial) for both the perpendicular axis and the angular axis. If not, P/S 5328 occurs when reference position establishment is tried.
 - (b) When the reference point establishment of angular and perpendicular axes are tried, please set parameter 8200#2(AZR) to '0' and input signal G063#5(NOZAGC) to '0'. If not, P/S 5328 occurs when reference position establishment is commanded.
 - (c) When the reference point of the perpendicular axis is established, it is necessary to establish the reference point of the angular axis previously. When the reference point of the angular axis is not previously established, the P/S090 alarm is generated.

- (d) During the reference point establishment operation of the angular axis, the command in the perpendicular axis is invalid in the manual reference point return.
- (e) On angular axis control, if you use automatic setting of parameter No.1883,1884 on reference point establishment (Prm. No.1819#2 (DATx)=1), please establish reference point of perpendicular axis after reference point establishment and return of angular axis.

Parameter

	#7	#6	#5	#4	#3	#2	#1	#0
1815					DCRx	DCLx	OPTx	

[Data type] Bit axis

OPTx Position detector

- 0 : A separate pulse coder is not used.
1 : A separate pulse coder is used.

DCLx As a separate position detector, the linear scale with reference absolute addressing mark (A/B phase)/the Linear scale with distance-coded reference marks (serial) is:

- 0 : Not used.
1 : Used

CAUTION

When using the linear scale with reference absolute addressing marks (A/B phase) or the linear scale with distance-coded reference marks (serial, full closed system), also set the OPTx parameter (bit 1 of parameters No.1815) to '1'. But when using the linear scale with distance-coded reference marks (serial, linear motor system), please set the OPTx parameter (bit 1 of parameters No.1815) to '0'.

DCRx As a scale with absolute addressing referenced marks:

- 0 : The linear scale is used.
1 : The rotary encoder is used.

CAUTION

- 1 Please set parameter DCLx to '1', too.
- 2 The rotary encoder with distance-coded reference marks (serial) is unavailable.

	#7	#6	#5	#4	#3	#2	#1	#0
1802						DC2	DC4	

[Data type] Bit

DC4 When the reference position is established on the linear scale with reference marks:

0 : An absolute position is established by detecting three reference marks.

1 : An absolute position is established by detecting four reference marks.

CAUTION

This parameter is unavailable on the linear scale with distance-coded reference marks (serial).

DC2 The reference position on the linear scale with absolute addressing referenced mark is established:

0 : 7As determined by bit 1(DC4) of parameter No.1802.

1 : By establishing the absolute position through detection of two reference marks.

CAUTION

1 When this parameter is set to 1, set the direction of scale zero in the parameter (No.1817#4 (SCPx)) correctly.

2 Even if DC2 is "1", the rotary axis (parameter 1815#3 (DCRx)=1) follows DC4.

3 This parameter is unavailable on the Linear scale with distance-coded reference marks (serial).

	#7	#6	#5	#4	#3	#2	#1	#0
1818					SDCx		RF2x	RFSx

[Data type] Bit axis

RFSx If an automatic reference position return (G28) is made before the reference position is established, the reference position is established first then,

0 : A movement to reference position is made.

1 : A movement to reference position is not made.

RF2x If an automatic reference position return (G28) is made after the reference position is established,

0 : A movement to the reference position is made.

1 : A movement to the reference position is not made, but the operation is completed.

SDCx Linear scale with distance-coded reference marks (serial) is

0 : Unavailable.

1 : Available.

WARNING

If you set parameter 1818#3 (SDCx), please don't forget to turned off before operation is continued. This parameter doesn't generate P/S alarm 0 (Power-off alarm).

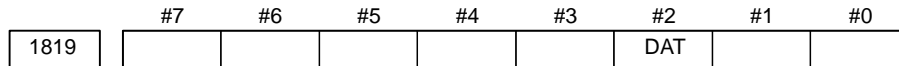

[Data type] Bit axis

DATx When manual reference point return is executed, the automatic setting of paramete 1883,1884 is:

- 0 : Not executed.
- 1 : Executed.

The procedure of the automatic setting are following :

- (1) Set a correct value to parameter No.1815,1821,1882.
 - * On the linear scale with distance-coded reference marks (serial), parameter No.1882 is unnecessary to set.
- (2) Positioning the axis to reference position by mechanical measurement by manual operation.
- (3) Execute manual reference point return.

When the manual reference point return is finished, parameter No.1883,1884 are set and No.1819#2 is turn to '0'.

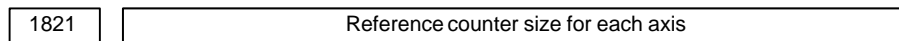

[Data type] 2-word axis

[Unit of data] Detection unit

[Valid data range] 0 to 99999999

Sets the intervals of mark 1 of the linear scale with absolute addressing referenced marks.

CAUTION

On the linear scale with distance-coded reference marks (A/B phase), this parameter is used on the usual purpose. (Setting reference counter size foreach axis)

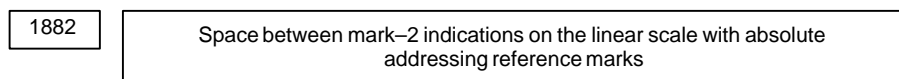

[Data type] 2-word axis

[Unit of data] Detection unit

[Valid data range] 0 to 99999999

Sets the intervals of mark 1 of the linear scale with absolute addressing referenced marks.

CAUTION

This parameter is unavailable on linear scale with distance-coded reference marks (serial).

1883

Distance 1 between the scale origin and reference position (for a linear scale with absolute addressing reference marks) or distance 1 between the reference point and reference position (for a linear scale with the absolute addressing origin)

[Data type] 2-word axis

[Unit of data] Detection unit

[Valid data range] -99999999 to 99999999

1884

Distance 2 between the scale origin and reference position (for a linear scale with absolute addressing reference marks) or distance 2 between the reference point and reference position (for a linear scale with the absolute addressing origin)

[Data type] Word axis

[Unit of data] Detection unit

[Valid data range] -20 to 20

When the distance between scale zero (or datum point) and reference position is over the setting range of parameter 1883, please set this parameter.

CAUTION

On using the linear scale with distance-coded reference marks (serial), when the value of this parameter is out of range, P/S alarm 5325 may occur on trying to establish the reference point.

(For a linear scale with absolute addressing reference marks)

Set the distance between scale zero and reference position by parameter No.1883, 1884. The actual distance is determined by following formula:

Actual distance = Parameter 1884 * 100,000,000 + Parameter 1883

The scale zero means a point where reference mark 1 and reference mark 2 are equal. Generally, this is a virtual point that exists on the out of scale stroke.(Refer to following figure)

When a reference point is located in plus side of a scale zero, set a plus value to this parameter. And a reference point is located in minus side, set a minus value.

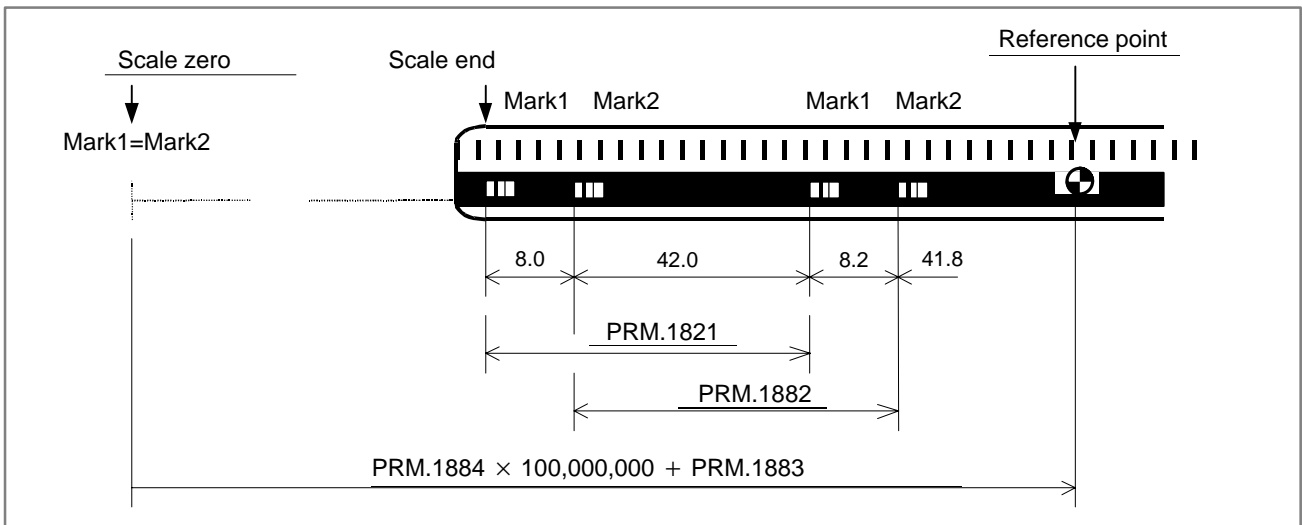

(For a linear scale with absolute addressing reference marks)

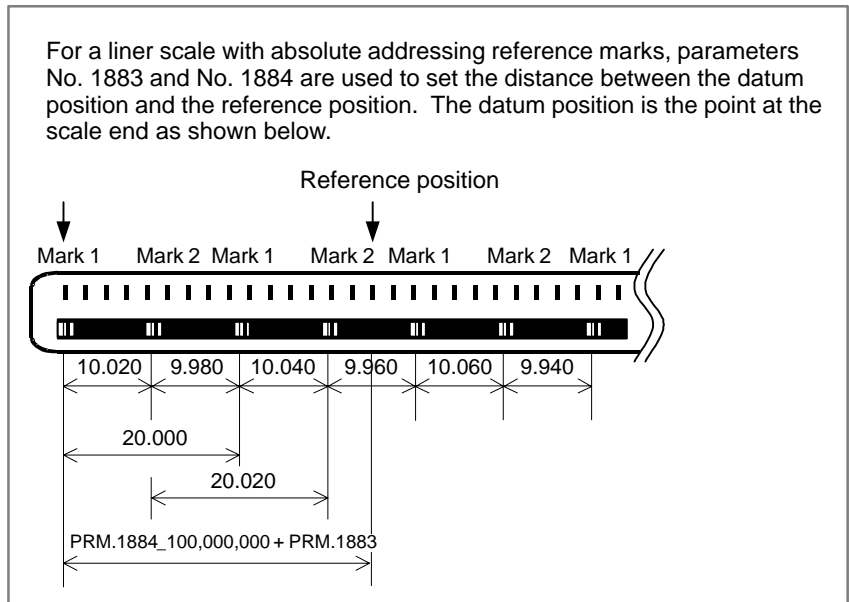

[Example of parameter setting]

(For a linear scale with absolute addressing reference marks)

When IS-B and millimeter machine and using a scale figured below:

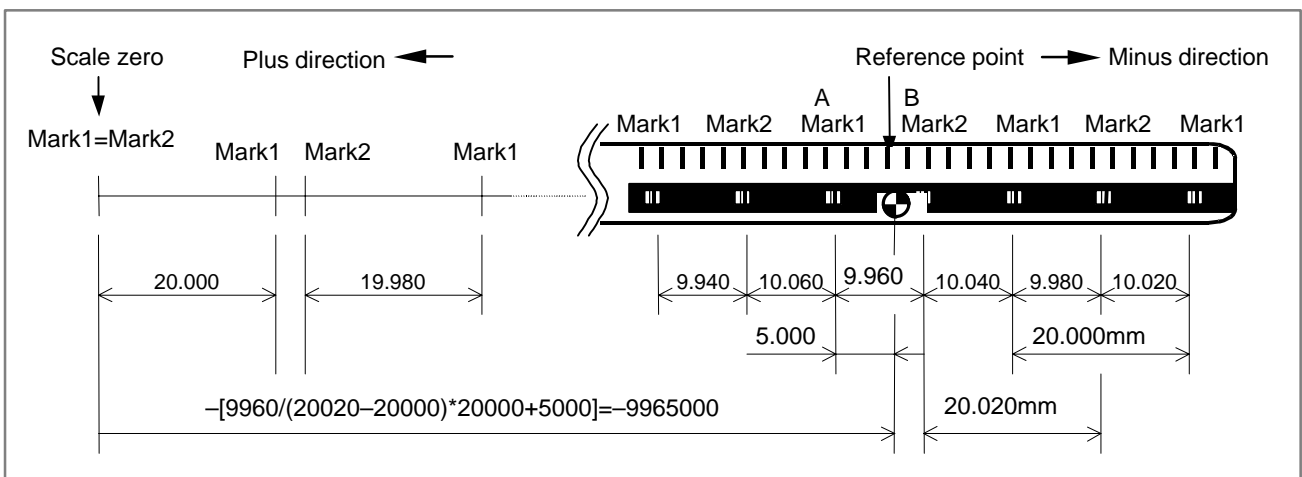

Parameter

No.1821 (Mark1 interval) = "20000"

No.1882 (Mark2 interval) = "20020"

No.1883 (Reference position) = Position of point A + 5.000

$$= (\text{Distance of A to B}) / (\text{Mark2 interval} - \text{Mark1 interval}) \times \text{Mark1 interval} + 5.000$$

$$= 9960 / (20020 - 20000) \times 20000 + 5000$$

$$= 9965000$$

"-9965000"(Reference point is located in minus side)

[The setting method of parameter No.1883]

(Linear scale with absolute addressing reference mark (A/B phase))

When the measurement of a parameter No.1883 (Distance between scale zero and reference position) is difficult, you can determine the setting value by the following procedure.

- (1) Set "1" to parameter No.1815#2,#1 to make this function available.
Set a correct value to parameter No.1821, No.1882.
Set "0" to parameter No.1240.
Set "0" to parameter No.1883,1884.
- (2) Establish a reference point by the procedure described in "1.2.1 Procedure for Reference Position Establishment". (As a result, the machine coordinate becomes the distance between scale zero and actual position.)
- (3) Positioning the axis to reference position by mechanical measurement in "HND" or "JOG" mode.
- (4) Set an actual machine coordinate value (DGN.301) to the parameter No.1883 after conversion of least command increment to detection unit. (Multiply DGN.301 and CMR)
- (5) Set a parameter No.1240 if necessary.

NOTE

When the setting value is greater than 99,999,999, this method can't be used.

[The setting method of parameter No.1883]

(Linear scale with distance-coded reference marks (serial))

Set a positive value when the reference position is located in the + direction when viewed from the reference point or a negative value when it is located in the - direction. The following shows the setting procedure:

- (1) Set bits 1 (OPTx) and 2 (DCLx) of parameter No. 1815 and bit 3 (SDCx) of parameter No. 1818 to enable this function.
Set "0" to parameter No.1240.
Set "0" to parameter No.1883,1884.
- (2) Establish a reference point by the procedure described in "1.3.1 Procedure for Reference Position Establishment". (As a result, the machine coordinate becomes the distance between datum point and actual position.)
- (3) Positioning the axis to reference position by mechanical measurement in "HND" or "JOG" mode.

- (4) Set an actual machine coordinate value (DGN.301) to the parameter No.1883 after conversion of least command increment to detection unit. (Multiply DGN.301 and CMR)
- (5) Set a parameter No.1240 if necessary.

NOTE

When the setting value is greater than 99,999,999, this method can not be used.

	#7	#6	#5	#4	#3	#2	#1	#0
1817				SCPx				

[Data type] Bit axis

- SCPx** If DC2x (Paramete No.1802#2) is set to '1', the scale-zero point of the linear scale with absolute addressing referenced mark is:
- 0 : On the negative direction side. (Viewed from the scale zero point, the reference position is on the positive direction side.)
 - 1 : On the positive direction side. (Viewed from the scale zero point, the reference position is on the negative direction side.)

CAUTION

- 1 An incorrect coordinate system will be established when a wrong value is set in this parameter. In such a case, please execute reference point return again after setting the correct value in this parameter.
- 2 This parameter is unavailable on linear scale with distance-coded reference marks (serial)

[Example]

When the parameter SCP is set to "0",

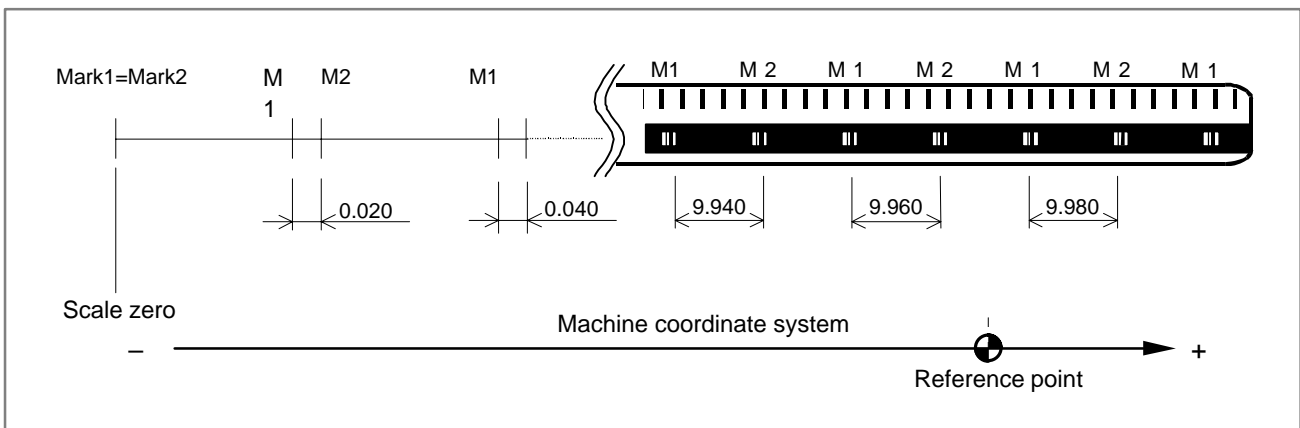

When the parameter SCP is set to "1",

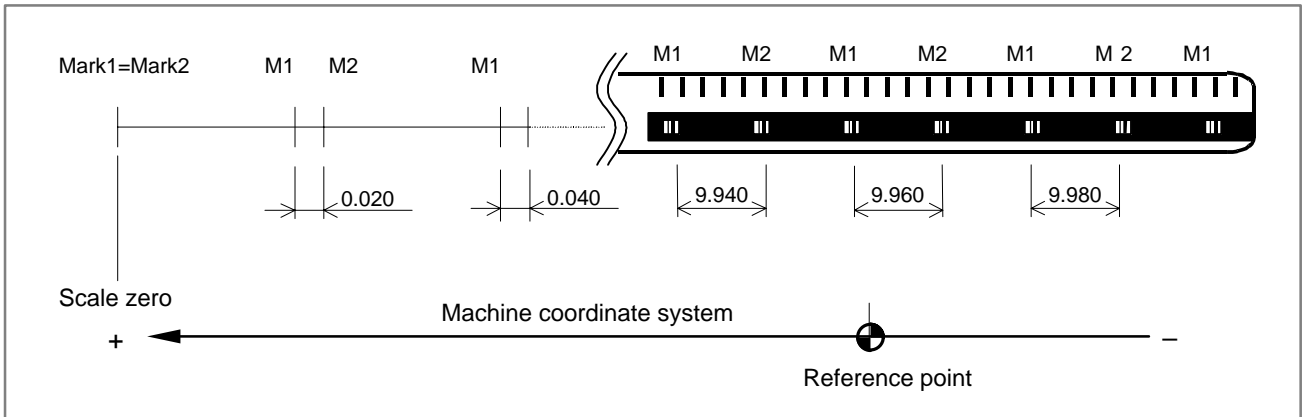

	#7	#6	#5	#4	#3	#2	#1	#0
8301	SOF							

[Data type] Bit

SOF The synchronization function in simple synchronous control (one pair) is:

- 0 : Not used.
- 1 : Used.

	#7	#6	#5	#4	#3	#2	#1	#0
8303	SOFx							

SOFx In simple synchronous control, the synchronization function is:

- 0 : Not used.
- 1 : Used.

NOTE

Set this parameter on the master axis side.

14010	Allowable move amount of FL feedrate on establishment of reference point (linear scale with distance-coded reference marks (serial))
-------	---

[Data type] 2-word axis

[Unit of data] Detection unit

[Valid data range] 0 to 99999999

On the linear scale with distance-coded reference marks (serial type), the amount of movement on FL-speed during establishment of reference point is set. If the reference point is not established despite the amount of FL-speed movement exceeds this parameter, P/S alarm 5326 occurs. When this parameter is set to '0', the setting of allowable move amount of FL feedrate on establishment of reference point (linear scale with distance-coded reference marks (serial)) is ineffective.

CAUTION

- 1 When a reference position is established on the M series by using the simple synchronous manual feed axis select signal <G140>, and this parameter is set for one of the master axis and slave axis, the setting is automatically applied to the other axis as well.
- 2 On angular axis control, this parameter setting of perpendicular axis is ignored during the reference position establishment of the angular axis.

Alarm and message

Number	Message	Description
090	REFERENCE RETURN INCOMPLETE	In case of Linear scale I/F with absolute address referenced mark (A/B phase), the actual interval of reference marks is different from parameter (No.1821, 1882) setting value.
5220	REFERENCE POINT ADJUSTMENT MODE	In case of Linear scale I/F with absolute address referenced mark (A/B phase) or Linear scale with distance-coded reference marks (serial), the reference point auto setting parameter (No.1819#2) is set to "1". Move the machine to reference position by manual operation and execute manual reference return.
5325	SERIAL DCL: FOLLOW-UP ERROR	<ol style="list-style-type: none"> 1. The amount of follow-up is more than 2147483648 or less than -2147483649 on detection unit. To reduce the follow-up amount, please adjust the point that we begin follow-up. 2. The value of parameter No.1884 is out of range.
5326	SERIAL DCL:REF-POS ESTABLISH ERR	The amount of movement for establish reference position was exceeded the amount of parameter 14010. Please try again or change parameter 14010 larger.

Number	Message	Description
5327	SERIAL DCL:MISMATCH (SSYNC CTRL)	Master/slave axes of simple synchronized control, one of them is the linear scale with distance-coded reference marks (serial), and the other of them is not the linear scale with distance-coded reference marks (serial). Please establish reference position with the input signal SYNCJn<g140> setting to zero.
5328	SERIAL DCL:MISMATCH (ANGL-AXIS)	On angular axis control, one of the angular/perpendicular axes is the scale with ref-pos, and the other of them is not the scale with ref-pos. Such system is not admired.

(*) P/S alarm 5325-5328 is generated only on Linear scale with distance-coded reference marks (serial)

4.9 EXTENDED FUNCTION OF THE LINEAR SCALE WITH ABSOLUTE ADDRESSING REFERENCE MARKS

The linear scale with absolute addressing reference marks has reference marks at intervals that change at a constant rate. By determining the reference mark interval, the corresponding absolute position can be deduced. When a G00 command or a move command in jog feed is specified for an axis for which the linear scale with absolute addressing reference marks is used, this function establishes the reference position by measuring the reference mark intervals automatically. Therefore, after CNC power-up, the reference position can be established without performing reference position return operation.

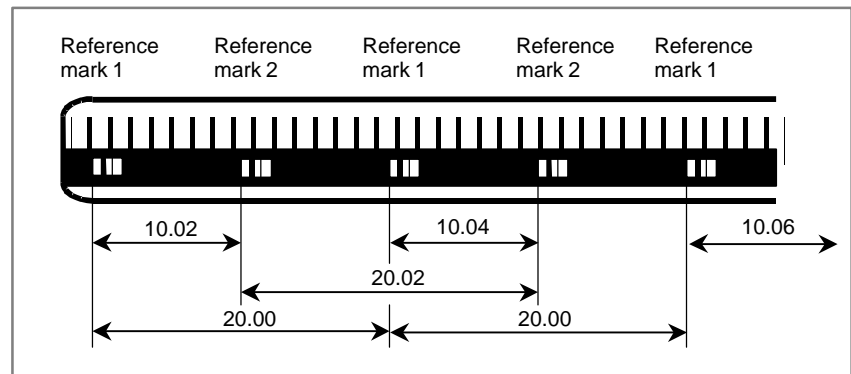

Fig. 4.9 (a) Sample linear scale with absolute addressing reference marks

To use this function, the interface option of the linear scale with absolute addressing reference marks is also required.

Reference position established by the G00 command

• Activation conditions

When the following conditions are satisfied, reference position establishment operation is performed automatically:

- <1> A G00 command is specified to cause a movement along an axis for which no reference position has been established.
- <2> The movement direction in <1> above matches the reference position return direction set by bit 5 (ZMI) of parameter No. 1006.
- <3> The specified axis is not in the following modes:
 - Three-dimensional coordinate conversion
 - Coordinate system rotation
 - Mirror image (mirror image by signal or setting)
 - Programmable mirror image (M series)
 - Scaling (M series)
 - High-precision contour control (M series)
 - AI nano contour control (M series)
 - Mirror image of facing tool posts (T series)

NOTE

If all the above conditions are not satisfied, the reference position establishment operation is not performed, and normal G00 command operation is performed.

• Operation

The reference position establishment procedure is explained below.

- <1> The tool is fed along a specified axis at the reference position return FL feedrate (parameter No. 1425).
 - <2> Upon detection of a reference mark on the scale, the tool is stopped briefly then fed at the reference position return FL feedrate.
 - <3> Step <2> above is repeated until three or four reference marks are detected on the scale. Then, the reference position is established, and the reference position established signal (ZRF1, ZRF2, ZRF3, etc.) is set to 1.
 - <4> The tool is fed to a specified end point at a rapid traverse rate.
- A time chart for the above procedure is shown below.

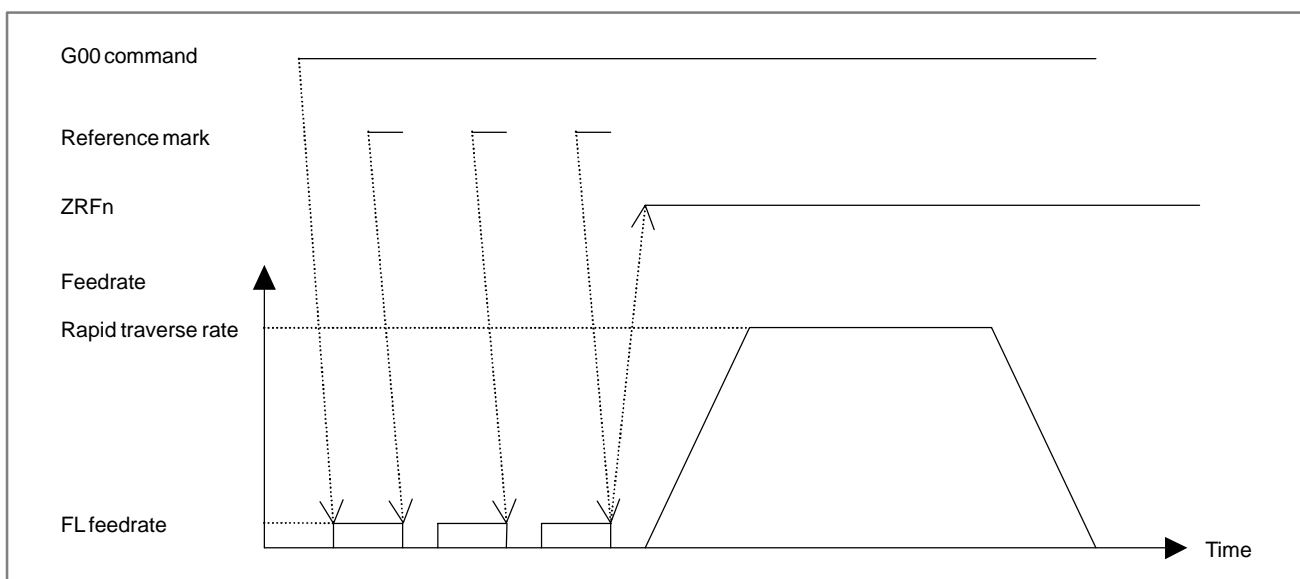

Fig. 4.9 (b) Time chart for reference position establishment (G00)

The specifications for the steps of detecting reference marks and establishing the reference position (steps <1> to <3> above) are the same as for the conventional linear scale with absolute addressing reference marks. The restrictions are also the same.

For details, see Section 4.8, "Linear Scale with Absolute Addressing Reference Marks".

• Tool path

The tool path in the G00 command is explained below.

- (1) When no axis requires the reference position establishment operation
 - When the reference position has already been established for all specified axes, the reference position establishment operation is not performed.
 - For example, suppose that the reference position is already established for the X-, Y-, and Z-axes, and that G00 Xxx Yyy Zzz; is specified. Then, normal rapid traverse operation takes place. The tool path follows the setting in bit 1 (LRP) of parameter No. 1401.

(2) When all axes require the reference position establishment operation

Suppose that the reference position is not established for the X-, Y-, and Z-axes and that `G00 Xxx Yyy Zzz;` is specified. The operation in this case is shown in the figure below.

Operation 1 in the figure establishes the reference position. During the establishment operation, the tool path is always of the non-linear interpolation type regardless of the setting in bit 1 (LRP) of parameter No. 1401.

Operation 2 performs positioning to a specified end point. During this operation, the tool path follows the setting in bit 1 (LRP) of parameter No. 1401.

After operation 1 is completed for all axes, operation 2 starts.

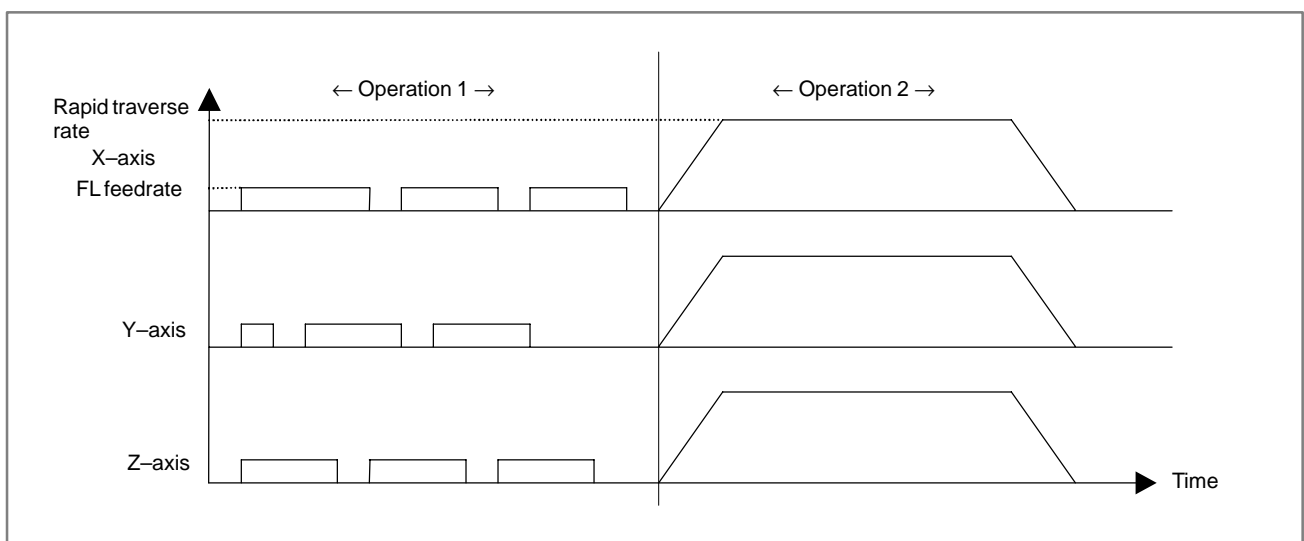

Fig. 4.9 (c) When the reference position is established for all axes

(3) When some axes require the reference position establishment operation and others do not require the establishment operation

For example, suppose that the reference position is already established for the X-axis and that the reference position is not yet established for the Y- and Z-axes. Also suppose that `G00 Xxx Yyy Zzz;` is specified. The operation in this case is shown in the figure below.

In operation 1 in the figure, movement to a specified position is made along the X-axis for which the reference position is already established. For the Y- and Z-axes for which no reference position is established, the reference position is established. During the establishment operation, the tool path is always of the non-linear interpolation type regardless of the setting in bit 1 (LRP) of parameter No. 1401.

In operation 2, positioning to a specified end point is performed along the Y- and Z-axes. The tool path along the Y- and Z-axes then follows the setting in bit 1 (LRP) of parameter No. 1401. Because positioning to the specified position is already made along the X-axis, no movement is made along the X-axis.

After operation 1 is completed for all axes, operation 2 starts.

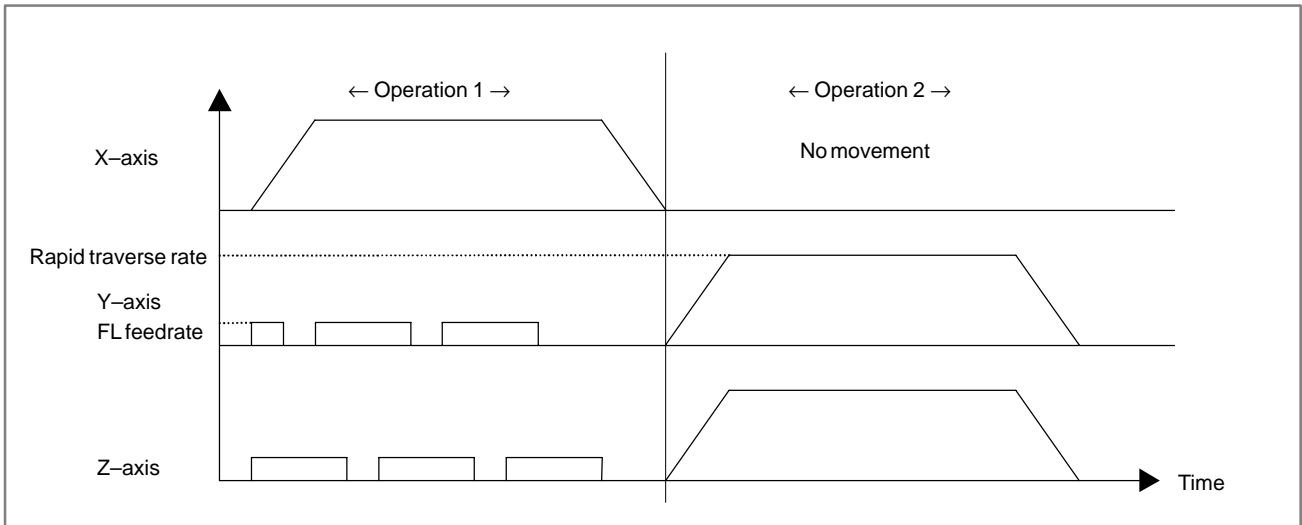

Fig. 4.9 (d) When an axis does not require the reference position establishment operation and others require the establishment operation

• **Absolute command and incremental command**

As explained in step <4>, after the reference position has been established, positioning to a specified end point is performed. This operation is explained below.

(1) When an absolute command is specified

Movement to the end point in the new coordinate system that has been established in step <3> is made. For example, when G90 G00 Xxx.Yyy.; (for the M series) or G00 Xxx.Zyy.; (for the T series) is specified, the tool moves as indicated with the bold line in the figure below. Note that, however, the figure shows the positional relationship among points and that the intermediate tool path is not always of the linear interpolation type.

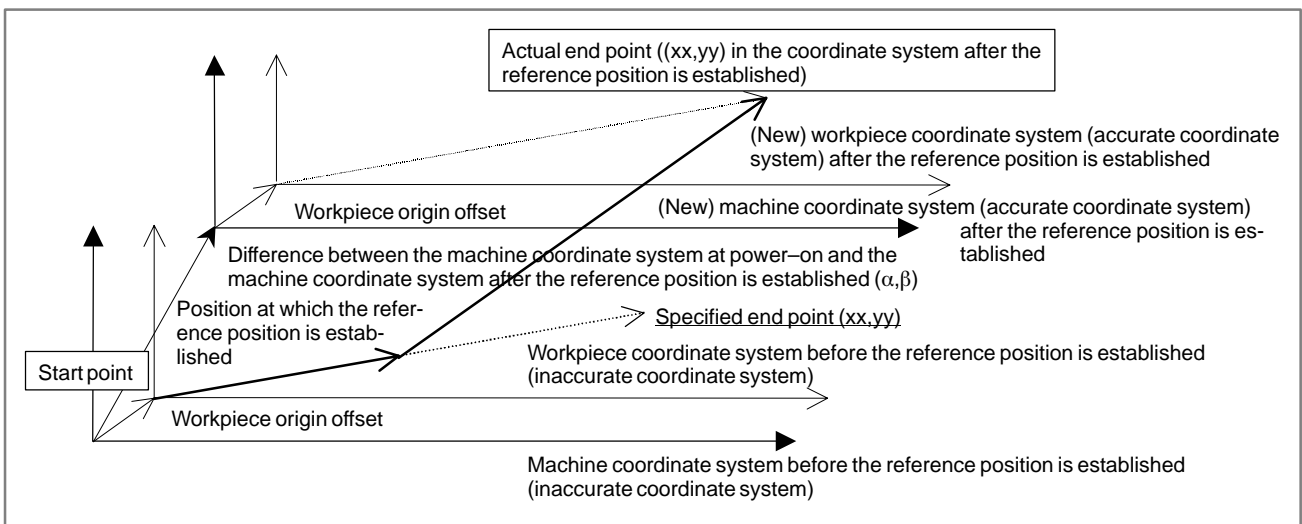

Fig. 4.9 (e) Operation when an absolute command is specified

(2) When an incremental command is specified

Movement is made along each axis by a specified distance. (The movement is indicated with the bold line in the figure below. Note that the intermediate tool path is not always of the linear interpolation type.) The coordinates at the end point are those in a newly established coordinate system. When there is a difference (α, β) between the newly established coordinate system and the old coordinate system, the coordinates at the end point are shifted by (α, β) . For example, when G91 G00 X100.Y30.; (M series) or G00 W100.U30.; (T series) is specified from the position of which absolute coordinates are (0,0), the distance of movement along each axis is (100,30), and the coordinates of the end point are $(100-\alpha, 30-\beta)$.

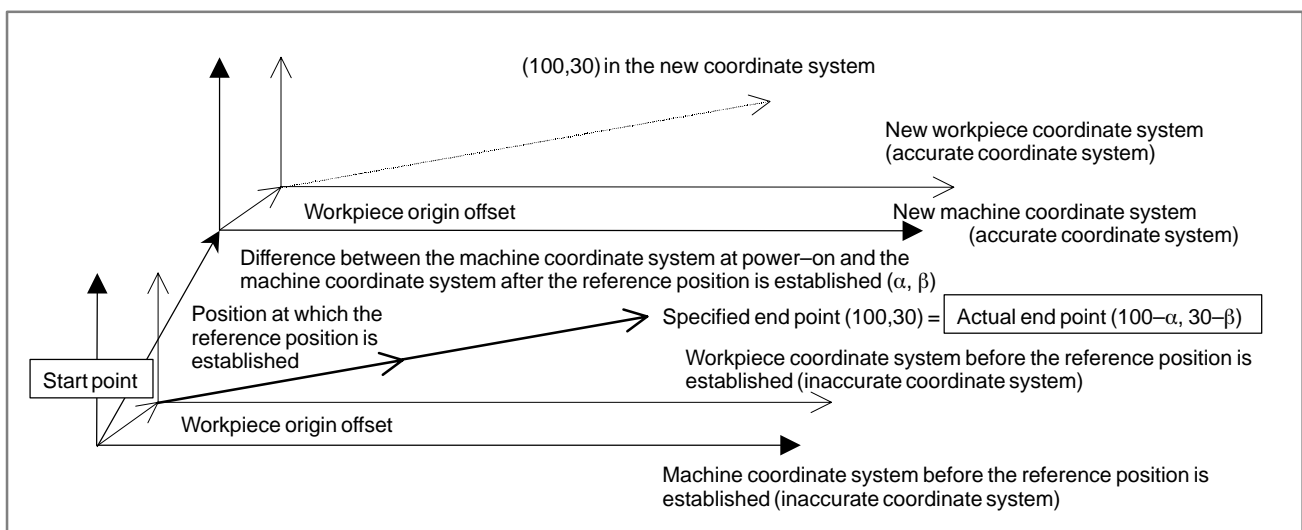

Fig. 4.9 (f) Operation when an incremental command is specified

- **When a short distance is specified**

When a short distance is specified, the end point can be reached before three or four reference marks are passed. Even in such a case, the CNC makes a movement at the FL feedrate while detecting reference marks, but the CNC does not establish the reference position even when the end point is reached.

If the reference position is not established, the next G00 command causes the reference position establishment operation again. The CNC does not use data on the reference marks detected through the previous movement and detects three or four reference marks again to establish the reference position.

- **Interruption by feed hold**

When a feed hold has been applied during reference position establishment operation, the reference position establishment operation is not performed after execution is restarted. After the restart, non-linear type positioning is performed. In this block, the reference position is not established, so reference position establishment operation is performed again when the next G00 command is specified.

- **Interruption by reset or emergency stop**

When a reset or emergency stop is applied during reference position establishment operation, the reference position establishment operation is interrupted. Since the reference position is not established, reference position establishment operation is performed again when the next G00 command is specified.

- **When an illegal reference mark interval is detected**

If a correct reference mark interval cannot be detected for a cause, the tool is positioned to the end point without establishing the reference position. Therefore, the machine position, absolute coordinates, and machine coordinates of the end point are set as if a G00 command without reference position establishment operation were executed. However, the intermediate tool path is different from the tool path obtained by executing the G00 command.

Since the reference position is not established, reference position establishment operation is performed again when the next G00 command is specified.

Even when the CNC detects an illegal reference mark interval, it does not issue the P/S090 alarm.

Reference position establishment by jog feed

- **Activation condition**

If the following conditions are satisfied, reference position establishment operation is performed automatically:

- <1> For an axis for which no reference position has been established, feed axis direction selection signal +Jn or -Jn (G100, G102) is input in jog mode.
- <2> The move direction in <1> above matches the reference position return direction set by bit 5 (ZMI) of parameter No. 1006.
- <3> The specified axis is not in the following modes:
 - Three-dimensional coordinate conversion
 - Coordinate system rotation
 - Mirror image (mirror image by signal or setting)
 - Programmable mirror image (M series)
 - Scaling (M series)
 - High-precision contour control (M series)
 - AI nano contour control (M series)
 - Mirror image of facing tool posts (T series)

NOTE

If all the above conditions are not satisfied, reference position establishment operation is not performed, and the same operation as normal jog feed is performed.

- **Operation**

The reference position establishment procedure is explained below.

- <1> When the feed axis direction selection signal is set to 1, the tool starts moving at the reference position return FL feedrate (parameter No. 1425).
- <2> Upon detection of a reference mark on the scale, the tool is stopped briefly then fed at the reference position return FL feedrate.
- <3> Step <2> above is repeated until three or four reference marks are detected on the scale. Then, the reference position is established, and the reference position established signal (ZRF1, ZRF2, ZRF3, etc.) is set to 1.
- <4> The tool is fed in the direction selected by the feed axis direction selection signal at the jog feedrate.

When the feed axis direction selection signal is set to 0 during steps <2> to <4>, feed operation stops. When the feed axis direction selection signal is set to 1 again, the reference position is established.

A time chart for the above procedure is shown below.

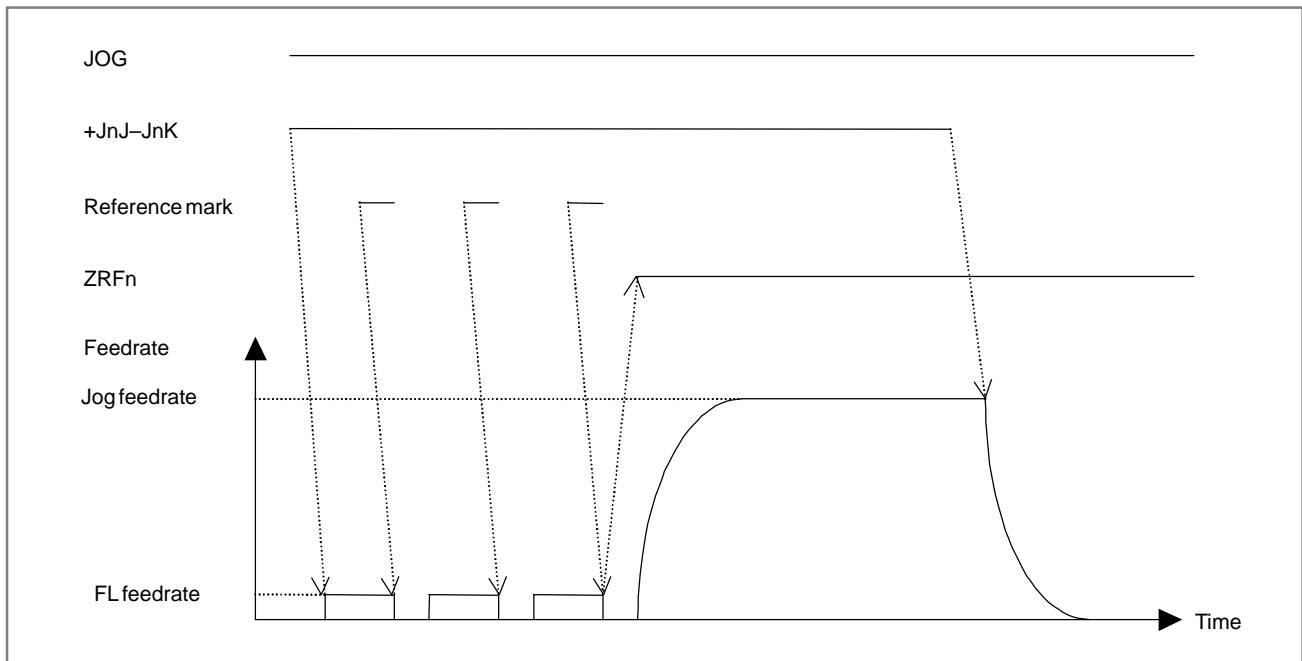

Fig. 4.9 (g) Time chart for reference position establishment (jog feed)

- **Interruption by a feed axis direction selection signal**

If feed axis direction selection signal +Jn (-Jn) is set to 0 during reference position establishment, the reference position establishment operation is interrupted. In this case, data on the reference marks detected through the previous movement is not used for the next reference establishment operation. When the feed axis direction selection signal +Jn (-Jn) is set to 1 again, the reference position establishment operation is resumed, and the reference position is established after three or four reference marks are detected.

- **Interruption by reset or emergency stop**

When a reset or emergency stop is applied during reference position establishment operation, axis movement stops, and the reference position establishment operation is interrupted. In this case, data on the reference marks detected through the previous movement is not used for the next reference establishment operation. When the feed axis direction selection signal +Jn (-Jn) is set to 1 again, the reference position is established after three or four reference marks are detected.

- **When an illegal reference mark interval is detected**

If a correct reference mark interval cannot be detected for a cause, reference position establishment operation is repeated until the reference position is established. Even when the CNC detects an illegal reference mark interval, it does not issue the P/S090 alarm.

Caution**CAUTION**

- 1 PMC axis control
In rapid traverse (axis control command 00h) and continuous feed (axis control command 06h) under PMC axis control, the reference position is not established.
- 2 Rapid traverse by other than G00
In rapid traverse operation generated automatically by a command such as a canned cycle command, the reference position is not established.
- 3 Reference position establishment operation
The specifications for detecting reference marks and establishing the reference position are the same as those of the conventional linear scale with absolute addressing reference marks. The parameter setting method and restrictions are also the same as those of the conventional linear scale with absolute addressing reference marks. For details, see Section 4.8, "Linear Scale with Absolute Addressing Reference Marks".

Parameter

	#7	#6	#5	#4	#3	#2	#1	#0
1818						DG0		

[Data type] Bit axis

DG0 Reference position establishment by the G00 command and jog feed is:

0 : Disabled.

1 : Enabled.

5

AUTOMATIC OPERATION



5.1 CYCLE START/ FEED HOLD

General

- **Start of automatic operation (cycle start)**

When automatic operation start signal ST is set to 1 then 0 while the CNC is in memory (MEM) mode, DNC operation mode (RMT), or manual data input (MDI) mode, the CNC enters the automatic operation start state then starts operating.

Signal ST, however, is ignored in the following cases:

1. When the mode is other than MEM, RMT, or MDI
2. When the feed hold signal (*SP) is set to 0
3. When the emergency stop signal (*ESP) is set to 0
4. When the external reset signal (ERS) is set to 1
5. When the reset and rewind signal (RRW) is set to 1
6. When MDI RESET key is pressed
7. When the CNC is in the alarm state
8. When the CNC is in the NOT READY state
9. When automatic operation is executing
10. When the program restart signal (SRN) is 1
11. When the CNC is searching for a sequence number.

The CNC enters the feed hold state and stops operation in the following cases during automatic operation:

1. When the feed hold signal (*SP) is set to 0
2. When the mode is changed to manual operation mode (JOG, INC, HND, REF, TJOG, or THND).

The CNC enters the automatic operation stop state and stops operating in the following cases during automatic operation:

1. When a single command block is completed during a single block operation
2. When operation in manual data input (MDI) mode has been completed
3. When an alarm occurs in the CNC
4. When a single command block is completed after the mode is changed to other automatic operation mode or memory edit (EDIT)

The CNC enters the reset state and stops operating in the following cases during automatic operation:

1. When the emergency stop signal (*ESP) is set to 0
2. When the external reset signal (ERS) is set to 1
3. When the reset and rewind signal (RRW) is set to 1
4. When MDI RESET key is pressed

The state of the CNC (automatic operation start, feed hold, automatic operation stop, or reset) is posted to the PMC with status output signals OP, SPL, and STL. See the table in the “Signal” section for details.

- **Halt of automatic operation (feed hold)**

When the feed hold signal *SP is set to 0 during automatic operation, the CNC enters the feed hold state and stops operation. At the same time, cycle start lamp signal STL is set to 0 and feed hold lamp signal SPL is set to 1. Re-setting signal *SP to 1 in itself will not restart automatic operation. To restart automatic operation, first set signal *SP to 1, then set signal ST to 1 and then to 0.

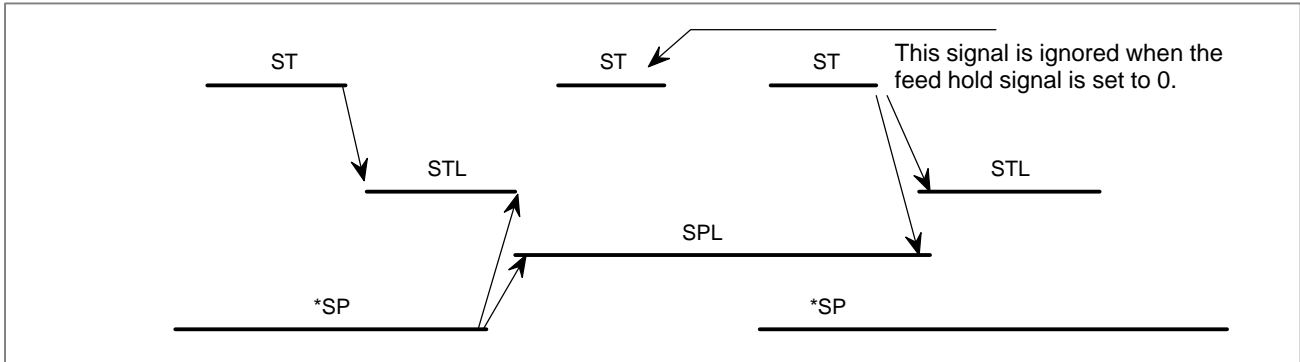

Fig. 5.1 Time chart for automatic operation

When signal *SP is set to 0 during the execution of a block containing only the M, S, T, or B function, signal STL is immediately set to 0, signal SPL is set to 1, and the CNC enters the feed hold state. If the FIN signal is subsequently sent from the PMC, the CNC executes processing up until the end of the block that has been halted. Upon the completion of that block, signal SPL is set to 0 (signal STL remains set to 0) and the CNC enters the automatic operation stop state.

(a) **During threading**

When signal *SP is set to 0 during threading, the CNC enters the feed hold state after executing a non-threading block after the threading blocks.

When signal *SP is set to 0 during threading with the G92 command (threading cycle), signal SPL is immediately set to 1 but operation continues up until the end of the retraction block following threading.

When signal *SP is set to 0 during threading with the G32 (M series: G33) command, signal SPL is immediately set to 1 but operation continues until the end of a non-threading block following the threading blocks. (Stopping feeding during threading is dangerous because the amount of cutting will increase.)

(b) **During tapping in a canned cycle (G84)**

When signal *SP is set to 0 during tapping in a canned cycle (G84), signal SPL is immediately set to 1 but operation continues until the tool returns to the initial level or R point level after the completion of tapping.

(c) **When a macro instruction is being executed**

Operation stops after the currently executing macro instruction has been completed.

Signal

Cycle start signal

ST <G007#2> [Classification] Input signal

[Function] Starts automatic operation.

[Operation] When signal ST is set to 1 then 0 in memory (MEM) mode, DNC operation mode (RMT) or manual data input (MDI) mode, the CNC enters the cycle start state and starts operation.

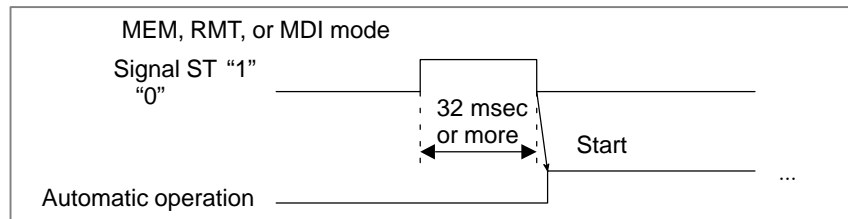

Feed hold signal

***SP <G008#5>** [Classification] Input signal

[Function] Halts automatic operation.

[Operation] When signal *SP is set to 0 during automatic operation, the CNC enters the feed hold state and stops operation. Automatic operation cannot be started when signal *SP is set to 0.

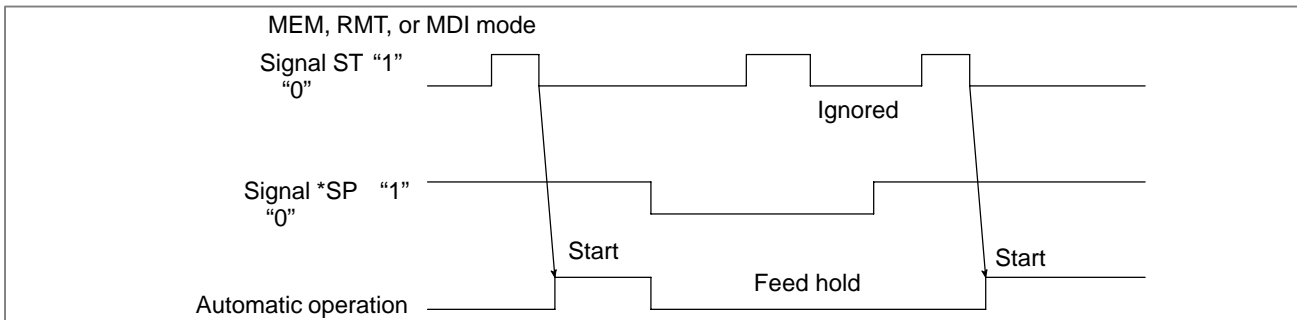

Automatic operation

signal [Classification] Output signal

OP <F000#7>

[Function] Notifies the PMC that automatic operation is in progress.

[Output condition] This signal is set to 1 or 0, according to the state of the CNC, as listed in Table 5.1.

Cycle start lamp signal

STL <F000#5> [Classification] Output signal

[Function] Notifies the PMC that automatic operation start is entered.

[Output condition] This signal is set to 1 or 0, according to the state of the CNC, as listed in Table 5.1.

Feed hold lamp signal

SPL <F000#4> [Classification] Output signal

[Function] Notifies the PMC that feed hold state is entered.

[Output condition] This signal is set to 1 or 0, according to the state of the CNC, as listed in Table 5.1.

Signals OP, STL, and SPL are the signals to inform PMC of the operation condition of CNC.

Table 5.1 Status of operation

State of the operation \ Signal name	Cycle start lamp STL	Feed hold lamp SPL	Automatic operation lamp OP
Cycle start state	1	0	1
Feed hold state	0	1	1
Automatic operation stop state	0	0	1
Reset state	0	0	0

- Cycle start state
The CNC is executing memory operation or manual data input operation commands.
- Feed hold state
The CNC is not executing memory operation nor manual data input operation commands while the commands to be executed remain.
- Automatic operation stop state
Memory operation or manual data input operation has been completed and stopped.
- Reset state
The automatic operation has been forcibly terminated.

NOTE

If the sequence number search is performed through MDI panel during Memory mode (MEM), the signal OP turns to "1".

● **Signal address**

	#7	#6	#5	#4	#3	#2	#1	#0
G007						ST		
G008			*SP					
	#7	#6	#5	#4	#3	#2	#1	#0
F000	OP		STL	SPL				

Alarm and message

- **Self-diagnosis information**

During automatic operation, the machine may sometimes show no movement while no alarm is detected. In that case, the CNC may be performing processing or waiting for the occurrence of an event. The state of the CNC can be obtained using the CNC self-diagnosis function (diagnosis numbers 000 to 015).

Detailed information on the automatic operation stop or feed hold state can also be displayed (diagnosis numbers 020 to 025).

Reference item

Series 16i/18i/160i/180i/ 160is/180is	OPERATOR'S MANUAL (For Machining Center) (B-63534EN)	III.4.1	MEMORY OPERATION
		III.4.2	MDI OPERATION
		III.4.3	DNC OPERATION
		III.7.3	CHECKING BY SELF- DIAGNOSTIC SCREEN
	OPERATOR'S MANUAL (For Lathe) (B-63524EN)	III.4.1	MEMORY OPERATION
		III.4.2	MDI OPERATION
		III.4.9	DNC OPERATION
		III.7.3	CHECKING BY SELF- DIAGNOSTIC SCREEN
Series 21i/210i/210is	OPERATOR'S MANUAL (For Machining Center) (B-63614EN)	III.4.1	MEMORY OPERATION
		III.4.2	MDI OPERATION
		III.4.3	DNC OPERATION
		III.7.3	CHECKING BY SELF- DIAGNOSTIC SCREEN
	OPERATOR'S MANUAL (For Lathe) (B-63604EN)	III.4.1	MEMORY OPERATION
		III.4.2	MDI OPERATION
		III.4.9	DNC OPERATION
		III.7.3	CHECKING BY SELF- DIAGNOSTIC SCREEN
Series 20i	OPERATOR'S MANUAL (For Manual Milling Machine) (B-64204EN)	III.4.1	MEMORY OPERATION
		III.4.2	MDI OPERATION
		III.4.3	DNC OPERATION
		III.7.3	CHECKING BY SELF- DIAGNOSTIC SCREEN
	OPERATOR'S MANUAL (For Manual Lathes) (B-64194EN)	III.4.1	MEMORY OPERATION
		III.4.2	MDI OPERATION
		III.4.8	DNC OPERATION
		III.7.3	CHECKING BY SELF- DIAGNOSTIC SCREEN

5.2 RESET AND REWIND

General

The CNC is reset and enters the reset state in the following cases:

1. When the emergency stop signal (*ESP) is set to 0
2. When the external reset signal (ERS) is set to 1
3. When the reset and rewind signal (RRW) is set to 1
4. When MDI RESET key is pressed

When the CNC is reset, the resetting signal (RST) is output to the PMC. The resetting signal (RST) is set to 0 when the resetting signal output time, set with parameter No. 3017, has elapsed after the above conditions have been released.

RST signal output time = T_{reset} (Reset processing time) + (parameter setting value) \times 16 msec.

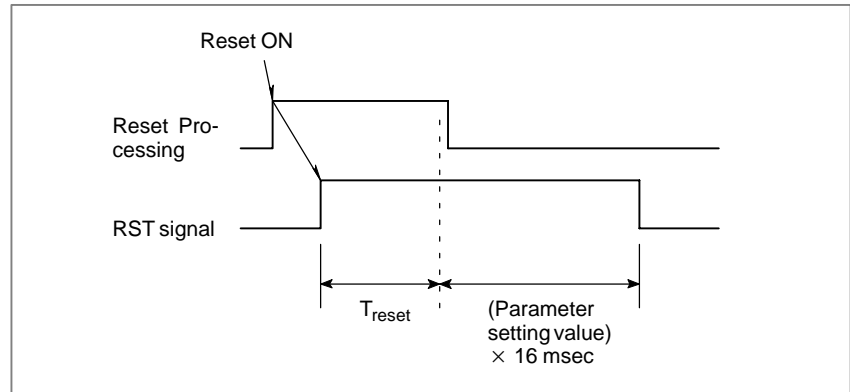

CAUTION

T_{reset} requires at least 16 msec. This time will be longer on optional configurations.

When the CNC is reset during automatic operation, automatic operation is stopped and tool movement along the controlled axis is decelerated and stopped(*1). When the CNC is reset during the execution of the M, S, T, or B function, signal MF, SF, TF, or BF is set to 0 within 100 ms.

Tool movement along the controlled axis is also decelerated and stopped(*1) in manual operation (jog feed, manual handle feed, incremental feed, or etc).

CAUTION

*1 When the emergency stop signal (*ESP) is set to 0, the tool is stopped by an emergency stop.

Bit 6 (CLR) of parameter No. 3402 is used to select whether the CNC internal data (such as modal G codes) is cleared or reset when the CNC is reset. Refer to the Appendix E, "Status when turning on power, when cleared, and when reset" in the Operator's manual for the state of the internal data when cleared or reset.

The following parameters are also used to select how to handle processing for CNC data when the CNC is reset.

- Bit 7 (MCL) of parameter No. 3203
Whether programs created in MDI mode are erased or stored
- Bit 6 (CCV) of parameter No. 6001
Whether custom macro variables #100 to #149 are cleared or stored
- Bit 7 (CLV) of parameter No. 6001
Whether custom macro local variables #1 to #33 are cleared or stored

• Reset & Rewind

When the reset & rewind signal (RRW) is set to 1, reset is performed and the following rewinding operation is also performed.

1. When the DNC operation mode, and a portable tape reader is connected as the current input/output device, the tape reader is rewound.

While the tape reader is being rewound, the rewinding-in-progress signal (RWD) is output. This signal goes 0 when the tape reader has been rewound.

2. In cases other than case 1, the head of the selected main program is searched for. Setting RWM, bit 2 of parameter no. 3001, determines whether the rewinding-in-progress signal is output.

When RWM is set to 1:

The rewinding-in-progress signal is output. It is set to 1, then set to 0 after about 100 ms. Since searching for the main program in memory takes little time, when the rewinding-in-progress signal (RWD) is set to 0, the main program has already been searched for.

Signal

External reset signal

ERS<G008#7>

[Classification] Input signal

[Function] Reset the CNC.

[Operation] Turning the signal ERS to 1 resets the CNC and enters the reset state. While the CNC is reset, the resetting signal RST turns to 1.

Reset & rewind signal

RRW<G008#6>

[Classification] Input signal

[Function] CNC is reset and a program under an automatic operation is rewound.

[Operation] As described in the item, "Reset & Rewind".

Resetting signal RST <F001#1>

[Classification] Output signal

[Function] Notifies the PMC that the CNC is being reset. This signal is used for reset processing on the PMC.

[Output condition] This signal is set to 1 in the following cases:

1. When the emergency stop signal (*ESP) is set to 0
2. When the external reset signal (ERS) is set to 1
3. When the reset & rewind signal (RRW) is set to 1
4. When MDI RESET key is pressed

This signal is set to 0 in the following case:

When the resetting signal output time, set with parameter No. 3017, has elapsed after the above conditions have been released and the CNC is reset

Rewinding signal RWD <F000#0>

[Classification] Output signal

[Function] Notifies the PMC that the CNC is being rewound.

[Output condition] As described in the item, “Reset and Rewind”.

Signal address

	#7	#6	#5	#4	#3	#2	#1	#0
G008	ERS	RRW						
F000								RWD
F001							RST	

Parameter

	#7	#6	#5	#4	#3	#2	#1	#0
3001						RWM		

[Data type] Bit

RWM RWD signal indicating that rewinding is in progress

0 : Output only when the tape reader is being rewound by the reset and rewind signal RRW

1 : Output when the tape reader is being rewound or a program in memory is being rewound by the reset and rewind signal RRW

3017	Output time of reset signal RST
------	---------------------------------

[Data type] Byte

[Unit of data] 16 ms

[Valid data range] 0 to 255

To extend the output time of reset signal RST, the time to be added is specified in this parameter.

RST signal output time = time required for reset + parameter value × 16 ms

	#7	#6	#5	#4	#3	#2	#1	#0
3203	MCL							

[Data type] Bit

MCL Whether a program prepared in the MDI mode is cleared by reset
 0: Not deleted
 1: deleted

	#7	#6	#5	#4	#3	#2	#1	#0
3402		CLR						

[Data type] Bit

CLR Reset key on the MDI panel, external reset signal, reset and rewind signal, and emergency stop signal
 0: Cause reset state.
 1: Cause clear state.

	#7	#6	#5	#4	#3	#2	#1	#0
6001	CLV	CCV						

[Data type] Bit

CCV Custom macro's common variables Nos. 100 through 149
 0: Cleared to "vacant" by reset
 1: Not cleared by reset

CLV Custom macro's local variables Nos. 1 through 33
 0: Cleared to "vacant" by reset
 1: Not cleared by reset

Reference item

Series 16 <i>i</i> /18 <i>i</i> /160 <i>i</i> /180 <i>i</i> / 160 <i>is</i> /180 <i>is</i>	OPERATOR'S MANUAL (For Machining Center) (B-63534EN)	APPENDIX E	STATUS WHEN TURNING POWER ON, WHEN CLEAR AND WHEN RESET
	OPERATOR'S MANUAL (For Lathe) (B-63524EN)	APPENDIX E	STATUS WHEN TURNING POWER ON, WHEN CLEAR AND WHEN RESET
Series 21 <i>i</i> /210 <i>i</i> /210 <i>is</i>	OPERATOR'S MANUAL (For Machining Center) (B-63614EN)	APPENDIX E	STATUS WHEN TURNING POWER ON, WHEN CLEAR AND WHEN RESET
	OPERATOR'S MANUAL (For Lathe) (B-63604EN)	APPENDIX E	STATUS WHEN TURNING POWER ON, WHEN CLEAR AND WHEN RESET
Series 20 <i>i</i>	OPERATOR'S MANUAL (For Manual Milling Machine) (B-64204EN)	APPENDIX E	STATUS WHEN TURNING POWER ON, WHEN CLEAR AND WHEN RESET
	OPERATOR'S MANUAL (For Manual Lathes) (B-64194EN)	APPENDIX E	STATUS WHEN TURNING POWER ON, WHEN CLEAR AND WHEN RESET

5.3 TESTING A PROGRAM

Before machining is started, the automatic running check can be executed. It checks whether the created program can operate the machine as desired. This check can be accomplished by running the machine or viewing the position display change without running the machine.

5.3.1 Machine Lock

General

The change of the position display can be monitored without moving the machine.

When all-axis machine lock signal MLK, or each-axis machine lock signals MLK1 to MLK8 are set to 1, output pulses (move commands) to the servo motors are stopped in manual or automatic operation. The commands are distributed, however, updating the absolute and relative coordinates. The operator can therefore check if the commands are correct by monitoring the position display.

Signal

All-axis machine lock signal MLK <G044#1>

[Classification] Input signal

[Function] Places all controlled axes in the machine lock state.

[Operation] When this signal is set to 1, pulses (move commands) are not output to the servo motors for all axes in manual or automatic operation.

Each-axis machine lock signals MLK1 to MLK8 <G108>

[Classification] Input signal

[Function] Place the corresponding controlled axes in the machine lock state. These signals are provided for each controlled axis. The signal number corresponds to the number of the controlled axis.

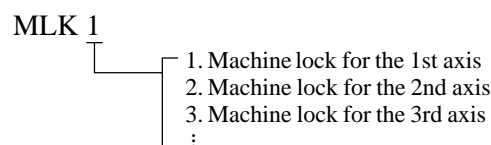

[Operation] When these signals are set to 1, pulses (move commands) are not output to the servo motors for the corresponding axes (1st to 8th) in manual or automatic operation.

**All-axis machine lock
check signal
MMLK <F004#1>**

[Classification] Output signal

[Function] Notifies the PMC of the state of the all-axis machine lock signal.

[Output condition] This signal is set to 1 in the following case:

- When all-axis machine lock signal MLK is set to 1

This signal is set to 0 in the following case:

- When all-axis machine lock signal MLK is set to 0

Signal address

	#7	#6	#5	#4	#3	#2	#1	#0
G044							MLK	
G108	MLK8	MLK7	MLK6	MLK5	MLK4	MLK3	MLK2	MLK1
F004							MMLK	

Note**NOTE****1 Automatic operation in the machine lock state (M, S, T, and B commands)**

Machine lock applies only to move commands along controlled axes. Updating modal G codes or setting a coordinate system is performed normally. M, S, T, and B (2nd auxiliary function) commands are also performed normally.

2 Reference position return in the machine lock state (G27, G28, and G30)

When the reference position return command (G28), or 2nd to 4th reference position return command (G30), is executed for an axis in the machine lock state, distribution and position updating are performed. The tool, however, is not returned to the reference position. The reference position return completion signals (ZP1 to ZP4) are not output.

The reference position return check command (G27) is ignored in the machine lock state.

3 Turning on/off the machine lock signal during movement along an axis

When the machine lock signal for an axis is set to 1 during movement along the axis that is not in the machine lock state, the axis is immediately placed in the machine lock state and output pulses (move commands) to the servo motor are stopped. The tool is decelerated and stopped with the automatic acceleration/deceleration function.

On the other hand, when the machine lock signal for an axis is set to 0 during distribution of the move command along the axis in the machine lock state, pulse (move command) output for the axis is immediately restarted. The tool is accelerated with the automatic acceleration/deceleration function.

Reference item

Series 16i/18i/160i/180i/ 160is/180is	OPERATOR'S MANUAL (For Machining Center) (B-63534EN)	III.5.1	MACHINE LOCK AND AUXILIARY FUNCTION LOCK
	OPERATOR'S MANUAL (For Lathe) (B-63524EN)	III.5.1	MACHINE LOCK AND AUXILIARY FUNCTION LOCK
Series 21i/210i/210is	OPERATOR'S MANUAL (For Machining Center) (B-63614EN)	III.5.1	MACHINE LOCK AND AUXILIARY FUNCTION LOCK
	OPERATOR'S MANUAL (For Lathe) (B-63604EN)	III.5.1	MACHINE LOCK AND AUXILIARY FUNCTION LOCK
Series 20i	OPERATOR'S MANUAL (For Manual Milling Machine) (B-64204EN)	III.5.1	MACHINE LOCK AND AUXILIARY FUNCTION LOCK
	OPERATOR'S MANUAL (For Manual Lathes) (B-64194EN)	III.5.1	MACHINE LOCK AND AUXILIARY FUNCTION LOCK

5.3.2 Dry Run

General

Dry run is valid only for automatic operation.

The tool is moved at a constant feedrate(*1) regardless of the feedrate specified in the program. This function is used, for example, to check the movement of the tool without a workpiece.

CAUTION

This feedrate depends on the specified parameters, the manual rapid traverse switching signal (RT), manual feedrate override signals (*JV0 to *JV15), and whether the command block specifies rapid traverse or cutting feed, as listed in the table below.

Manual rapid traverse switching signal (RT)	Program command	
	Rapid traverse	Feed
1	Rapid traverse rate	Dry run feedrate \times JV_{max} *2
0	Dry run speed \times JV, or rapid traverse rate *1	Dry run feedrate \times JV *2

Max. cutting feedrate . . . Setting by parameter No.1422

Rapid traverse rate Setting by parameter No.1420

Dry run feedrate Setting by parameter No.1410

JV Manual feedrate override

JV_{max} Maximum value of manual feedrate override
 *1: Dry run feedrate \times JV when parameter RDR (bit 6 of No. 1401) is 1.
 Rapid traverse rate when parameter RDR is 0.
 *2 Clamped by max. cutting feedrate.

Signal

**Dry run signal
 DRN <G046#7>**

[Classification] Input signal

[Function] Enables dry run.

[Operation] When this signal is set to 1, the tool is moved at the feedrate specified for dry run.
 When this signal is set to 0, the tool is moved normally.

CAUTION
 When the dry run signal is changed from 0 to 1 or 1 to 0 during the movement of the tool, the feedrate of the tool is first decelerated to 0 before being accelerated to the specified feedrate.

**Dry run check signal
 MDRN <F002#7>**

[Classification] Output signal

[Function] Notifies the PMC of the state of the dry run signal.

[Output condition] This signal is set to 1 in the following case:
 – When dry run signal DRN is set to 1
 This signal is set to 0 in the following case:
 – When dry run signal DRN is set to 0

Signal address

	#7	#6	#5	#4	#3	#2	#1	#0
G046	DRN							
F002	MDRN							

Parameter

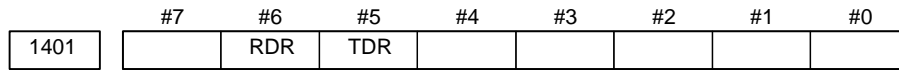

[Data type] Bit

TDR Dry run during threading or tapping (tapping cycle G74 or G84; rigid tapping)

- 0 : Enabled
- 1 : Disabled

RDR Dry run for rapid traverse command

- 0 : Disabled
- 1 : Enabled

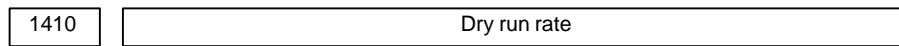

[Data type] Word

[Unit of data]

[Valid data range]

Increment system	Unit of data	Valid data range	
		IS-A, IS-B	IS-C
Millimeter machine	1 mm/min	6 – 15000	6 – 12000
Inch machine	0.1 inch/min	6 – 6000	6 – 4800

Set the dry run rate when the manual feedrate is overridden by 100%.

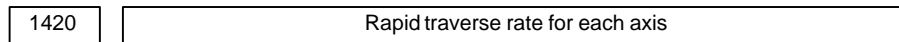

[Data type] Two-word axis

[Unit of data]

[Valid data range]

Increment system	Unit of data	Valid data range	
		IS-A, IS-B	IS-C
Millimeter machine	1 mm/min	30 – 240000	6 – 100000
Inch machine	0.1 inch/min	30 – 96000	6 – 48000
Rotation axis	1 deg/min	30 – 240000	30 – 100000

Set the rapid traverse rate when the rapid traverse override is 100% for each axis.

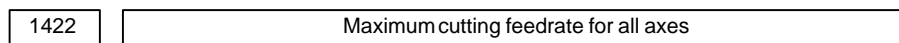

[Data type] Two-word

[Unit of data]

[Valid data range]

Increment system	Unit of data	Valid data range	
		IS-A, IS-B	IS-C
Millimeter machine	1 mm/min	6 – 240000	6 – 100000
Inch machine	0.1 inch/min	6 – 96000	6 – 48000

Specify the maximum cutting feedrate.

A feedrate in the tangential direction is clamped in cutting feed so that it does not exceed the feedrate specified in this parameter.

NOTE

To specify the maximum cutting feedrate for each axis, use parameter No. 1430 instead.

Reference item

Series 16i/18i/160i/180i/ 160is/180is	OPERATOR'S MANUAL (For Machining Center) (B-63534EN)	III.5.4	Dry run
	OPERATOR'S MANUAL (For Lathe) (B-63524EN)	III.5.4	Dry run
Series 21i/210i/210is	OPERATOR'S MANUAL (For Machining Center) (B-63614EN)	III.5.4	Dry run
	OPERATOR'S MANUAL (For Lathe) (B-63604EN)	III.5.4	Dry run
Series 20i	OPERATOR'S MANUAL (For Manual Milling Machine) (B-64204EN)	III.5.4	Dry run
	OPERATOR'S MANUAL (For Manual Lathes) (B-64194EN)	III.5.4	Dry run

5.3.3 Single Block

General

Single block operation is valid only for automatic operation.

When the single block signal (SBK) is set to 1 during automatic operation, the CNC enters the automatic operation stop state after executing the current block. In subsequent automatic operation, the CNC enters the automatic operation stop state after executing each block in the program. When the single block signal (SBK) is set to 0, normal automatic operation is restored.

Single block operation during the execution of custom macro statements depends on the setting of bit 5 (SBM) of parameter No. 6000, as follows:

SBM = 0, SBV = 0: Operation does not stop in the custom macro statements but stops once the next NC command has been executed.

SBM = 1: Operation stops after each block in the custom macro statements.

SBV = 1: Single block operation in custom macro statements is suppressed using macro system variable #3003. Execution of custom macro statements is stopped after block execution.

When the CNC is in the automatic operation stop state during single block operation, the mode can be changed to manual data input (MDI), manual handle feed (HNDL), incremental feed (INC), or jog feed (JOG), by using the mode select signals (MD1, MD2, and MD4).

Signal

Single block signal SBK <G046#1>

[Classification] Input signal

[Function] Enables single block operation.

[Operation] When this signal is set to 1, single block operation is performed. When this signal is set to 0, normal operation is performed.

Single block check signal MSBK <F004#3>

[Classification] Output signal

[Function] Notifies the PMC of the state of the single block signal.

[Output condition] This signal is set to 1 in the following case:
 – When single block signal SBK is set to 1

This signal is set to 0 in the following case:
 – When single block signal SBK is set to 0

Signal address

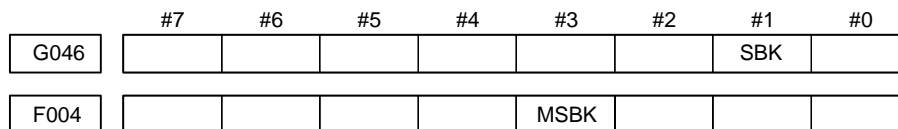

Parameter

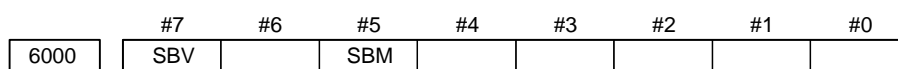

[Data type] Bit

SBM Custom macro statement
 0: Not stop the single block
 1: Stops the single block

If you want to disable the single blocks in custom macro statements using system variable #3003, set this parameter to 0. If this parameter is set to 1, the single blocks in custom macro statements cannot be disabled using system variable #3003. To control single blocks in custom macro statements using system variable #3003, use bit 7 (SBV) of parameter No. 6000.

NOTE

This bit is invalid when bit 0 (NOP) of parameter No. 6000 is set to 1. (M series)

SBV Custom macro statement
0 : Not stop the single block
1 : Stops the single block

To control single blocks in custom macro statements using system variable #3003, use this parameter to enable or disable single blocks in custom macro statements.

This bit is valid when bit 5 (SBM) of parameter No. 6000 is set to 0.

Caution**CAUTION****1 Operation in thread cutting**

When the SBK signal turns to "1" during thread cutting, operation stops after execution of the first non-thread cutting block after the thread cutting command.

2 Operation in canned cycle

When the SBK signal turns to "1" during canned cycle operation, the operation stops at each positioning, approach, drilling and retreat instead of the end of the block. The SPL signal turns to "1" while the STL signal turns to "0", showing that the end of the block has not been reached. When the execution of one block is completed, the STL and SPL signals turn to "0" and the operation is stopped.

Reference item

Series 16i/18i/160i/180i/ 160is/180is	OPERATOR'S MANUAL (For Machining Center) (B-63534EN)	III.5.5	Single block
	OPERATOR'S MANUAL (For Lathe) (B-63524EN)	III.5.5	Single block
Series 21i/210i/210is	OPERATOR'S MANUAL (For Machining Center) (B-63614EN)	III.5.5	Single block
	OPERATOR'S MANUAL (For Lathe) (B-63604EN)	III.5.5	Single block
Series 20i	OPERATOR'S MANUAL (For Manual Milling Machine) (B-64204EN)	III.5.5	Single block
	OPERATOR'S MANUAL (For Manual Lathes) (B-64194EN)	III.5.5	Single block

5.3.4 Manual Handle Retrace (T Series)

General

A manual handle (a manual pulse generator) can be used during automatic operation to allow forward or backward program execution. By doing this while actually operating the machine, you can check programs to find errors and other problems easily.

• Check mode

In check mode, a program can be executed in the forward or backward direction to check the program.

To enter check mode, place the CNC in memory operation mode, and set check mode signal G0067#2 (MMOD) to 1. In check mode, this function creates data for backward movement when forward program execution is performed.

To synchronize operation with pulses from the manual pulse generator in check mode, set check mode handle valid signal G0067#3 (MCHK) to 1 in addition to the steps explained above. Then, you can check a program using the manual pulse generator.

NOTE

In check mode, neither offsets nor parameters can be altered.

- **Forward movement**

Forward movement is to execute a program in the forward direction regardless of the rotation of the manual pulse generator (with the check mode handle valid signal MCHK set to 0) or by rotating the manual pulse generator in the positive direction (with the manual handle check signal set to 1).

If the check mode handle valid signal MCHK is set to 1, the program execution speed is directly proportional to the number of manual pulse generator rotations. When you turn the manual pulse generator in the positive direction quickly, the speed increases; when you turn the manual pulse generator slowly, the speed decreases. The travel distance per pulse generated from the manual pulse generator can be changed by changing the magnification in the same manner as for ordinary handle feed.

If the check mode handle valid signal MCHK is 0, program execution is controlled in the same manner as for automatic operation.

- **Backward movement**

Backward movement is to execute in the backward direction a program once executed in the forward direction, by rotating the manual pulse generator in the negative direction.

Backward program execution is possible only for those blocks that have been executed in the forward direction. About 200 blocks can be executed in the backward direction. The number of blocks that can be executed in the backward direction varies depending on the contents of a specified program. The backward program execution speed is directly proportional to the number of manual pulse generator rotations. When you turn the manual pulse generator in the negative direction quickly, the speed increases; when you turn the manual pulse generator slowly, the speed decreases. The travel distance per pulse generated from the manual pulse generator can be changed by changing the magnification in the same manner as for ordinary handle feed.

Details

Operation

- **Starting execution**

In memory operation mode, set check mode signal G0067#2 (MMOD) to 1 to place the CNC in check mode, then set the ST signal from 1 to 0. Then, program execution starts.

If check mode handle valid signal G0067#2 (MCHK) is 1 at this point, program execution in check mode is controlled by pulses generated from the manual pulse generator so that operation is synchronized with these pulses. If check mode handle valid signal MCHK is 0, program execution is controlled in the same way as ordinary operation.

NOTE

- 1 To use the manual pulse generator for forward or backward movement, place the CNC in check mode before starting program execution. The check mode signal must not be driven to 1 in a midway point of program execution.
- 2 If the signal is set to 0 in a midway point of a program, the manual pulse generator is no longer used for the subsequent forward or reverse movement.

- **Control using the manual pulse generator**

The machine travel distance per pulse generated from the manual pulse generator is determined by parameter No. 6410 and handle magnification. The machine travel distance when the manual pulse generator is actually rotated is obtained from the following expression:

$$[\text{Specified feedrate}] \times [\text{the number of handle pulses per second}] \\ \times [\text{handle magnification}] \times ([\text{parameter setting}]/100) \times (8/1000)$$

If the manual pulse generator is rotated so quickly that the feedrate obtained by applying an override of 100% is exceeded, the feedrate is clamped to the 100% overridden feedrate. Therefore, if pulses are generated from the manual pulse generator so that the value obtained from the following expression exceeds 1, the feedrate is clamped:

$$[\text{The number of handle pulses per second}] \times [\text{handle magnification}] \\ \times ([\text{parameter setting}]/100) \times (8/1000)$$

The rapid traverse rate is normally clamped to the 10% overridden feedrate. The rapid traverse rate can be clamped to the 100% overridden feedrate by setting bit 0 (HRP) of parameter No. 6400 to 1.

The single block stop signal and feed hold signal are valid also during control by the manual pulse generator. When operation is stopped after single-block execution or by feed hold, program execution is kept stopped until the ST signal is driven from 1 to 0. For blocks specifying a movement and blocks specifying dwelling, the program execution speed can be controlled by rotating the manual pulse generator. For blocks containing just M, S, T, and F codes that specify neither movement nor dwelling, control is passed to the next block even when the manual pulse generator is not rotated.

The spindle speed is not synchronized with pulses generated from the manual pulse generator. Even in check mode, the spindle turns at a specified speed. When a feed per revolution is performed, the CNC internally calculates the value equivalent to feed per minute from the current spindle speed.

NOTE

The manual pulse generator used in this function is always the first manual pulse generator. The second and third manual pulse generators cannot be used.

- **Forward/backward movement by the manual pulse generator**

A program is executed in the forward direction by turning the manual pulse generator in the positive direction, and the program is executed in the backward direction by turning the manual pulse generator in the negative direction.

When the manual pulse generator is turned reversely during forward movement, the program is executed in the backward direction immediately. As the manual pulse generator is turned in the negative direction continuously, the program is executed in the backward direction, and program execution stops when a block having an O number is encountered. Then, by turning the manual pulse generator in the positive direction, the program is executed in the forward direction.

When the check mode handle valid signal MCHK is set to 0 during forward or backward movement by the manual pulse generator, the program is executed in the forward direction regardless of the direction of manual pulse generator rotation.

- **End of execution**

Executing an M2 or M30 block stops program checking. Backward movement cannot be performed from the M2 or M30 block. After program execution ends, set the RESET signal to 1, and set the check mode signal and check mode handle valid signal MCHK to 0.

When two-path control is performed, the FIN signal must not be sent when just one path encounters M2 or M30. The FIN signal must be sent after both paths have encountered M2 or M30. (This is not required when the block immediately before M2 or M30 contains a wait M code.)

- **Notes on operation**

- In check mode, dry run cannot be used. Be sure to set the dry run signal to 0.
- When the check mode or check mode handle valid signal MCHK is set to 0 while a program is being executed in check mode, automatic operation of the program starts immediately in the forward direction at a specified feedrate.
- Be sure to start executing a program from its beginning.
- During program execution, do not change mode to perform program editing and parameter and offset modification.

- **Backward execution of each code**

At the time of forward movement, modal information of G, T, and S codes is all stored for use for backward movement.

Like G codes, M codes can be managed as grouped modal codes by setting parameter Nos. 6411 to 6490. Therefore, M codes can also be executed in the backward direction according to the modal information.

Except G, M, S, and T codes, the same code as output at the time of forward movement is output at backward movement.

- **G codes**

When a G code that changes modal information is executed in the backward direction, the modal information present one block before is used for execution. When a G code is accompanied by a move command, the tool is fed reversely along the path of forward movement.

The following G codes can be executed in the backward direction:

G00	G01	G02	G03	G04	G22	G23
G25	G26	G28	G30	G40	G41	G42
G50	G53	G70	G71	G72	G73	G74
G75	G83	G86	G90	G94	G96	G97
G98	G99					

(G code system A)

G codes other than the above cannot be executed in the backward direction. (For inhibition of backward movement, see "Inhibition of Backward Movement".)

G code systems B and c can also be used.

- **M codes**

Among M codes grouped by parameter setting, the M code present one block before is output.

When an M code not grouped by parameter setting is encountered, the same M code output at forward movement is output.

- **S and T codes**

The modal value for the block before the current block is output.

● Inversion inhibition

In the inversion inhibition state, the program execution direction cannot be changed. When the manual pulse generator is rotated in the direction opposite to the direction of the previous rotation in the inversion inhibition state, the rotation in the opposite direction is ignored. In this case, rotate the manual pulse generator in the same direction as the previous direction to release the inversion inhibition state.

Whether the system is in the inversion inhibition state or not can be checked using inversion inhibition signal MNCHG <F0091#1>.

The inversion inhibition state is entered when one of the following conditions is met:

- During execution of a block containing a code that causes a FIN wait
- During the time from the end of a block until processing of another block starts
- During threading
- While operation is stopped in single block mode or by feed hold

● Inhibition of backward movement

The backward movement inhibition state is entered when program execution in the backward direction cannot be performed for a certain block and subsequent blocks.

In the backward movement inhibition state, rotation of the manual pulse generator in the negative direction is ignored, and only the rotation in the positive direction is valid. To release the backward movement inhibition state, rotate the manual pulse generator in the positive direction to execute the program in the forward direction.

Whether the CNC is in the backward movement inhibition state or not can be checked using the backward movement inhibition signal MRVSP <F0091#2>.

An attempt to execute the following blocks in the backward direction places the CNC in the backward movement inhibition state:

- Program number blocks (except subprograms and macro programs)
- Blocks more than the number of blocks that can be executed in the backward direction
- Blocks containing the following G codes and modal information:

G05	G07	G07.1	G10	G10.6	G11	G12.1
G13.1	G17	G18	G19	G20	G21	G27
G30.1	G31	G32	G33	G34	G35	G36
G37	G38	G39	G50.3	G50.2	G51.2	G52
G54	G55	G56	G57	G58	G59	G65
G66	G67	G68	G69	G68.1	G69.1	G76
G80	G84	G87	G88	G89	G92	

(G code system A)

Other notes

• **Move command plus M, S, and T codes**

When a block contains a move command and an M, S, or T code, the time when the M, S, or T code is output differs between forward movement and backward movement. Therefore, at the time of backward movement, some measures are sometimes required. For example, process M, S, or T after checking that the DEN signal is set to 1.

```

Example:  O0001 ;
          M5 S0 F0 ;
          G53 X0 Z0 ; .....(1)
          G1 W100 M3 S100 F1. ; .....(2)
          G0 U50. W50. ; .....(3)
          M2 ;
    
```

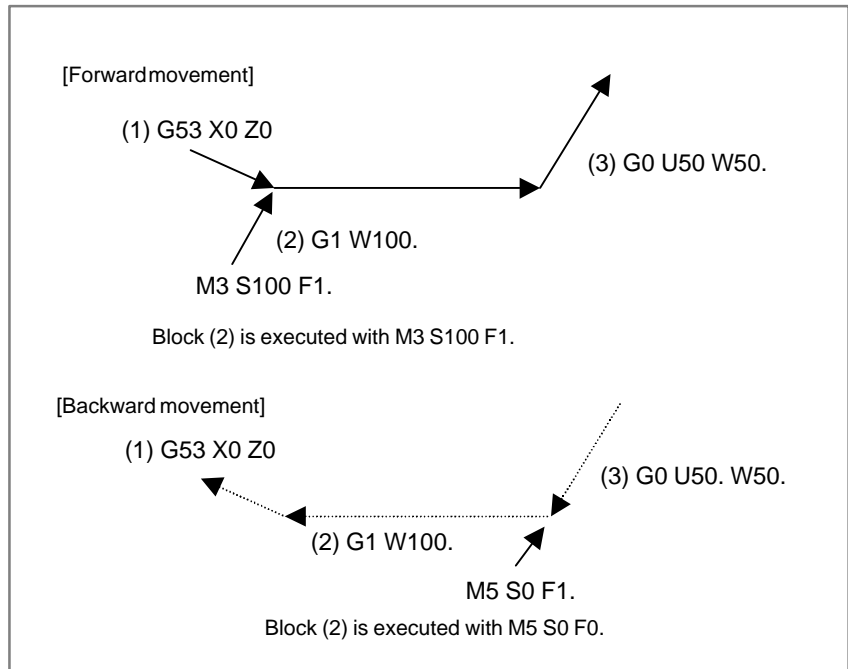

• **Non-linear type positioning**

The path of non-linear type positioning differs between forward movement and backward movement.

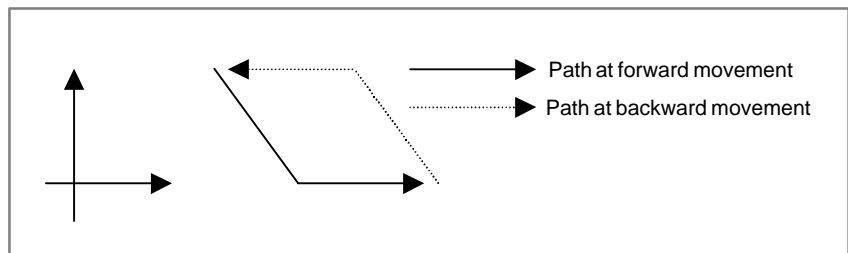

CAUTION
 For risk prevention, use interpolation type positioning (set bit 1 (LRP) of parameter No. 1401 to 1).

- **Forward execution of threading** During execution of threading blocks (G32, G76, G84, G88, and G92), handle pulses are ignored, and these blocks are always executed at a feedrate with an override of 100%. In a threading cycle, pulses are ignored only when threading is being performed; for other movement operations, pulses become valid.

- **Multiple M codes in a block** When backward movement is performed for a block containing multiple M codes, the same M codes as output when forward movement was performed are output as the second and third M codes.

- **Macro variables** Variable assignments and operations in macro statements are performed only in the first forward program execution since check mode is entered. This means that once variable assignments and operations have been performed in blocks, variable assignments and operations are no longer performed again in these blocks regardless of the block execution direction.

- **Simultaneous specification with a program number block** When a move command is specified together with a program number block, the command cannot be executed in the backward direction. When this function is used, a program number block and a move block must be specified separately.

- **Threading cycle retract** When a threading cycle retract operation is performed during forward movement, the subsequent program checking cannot be continued. In this case, program execution must be stopped by a reset, and the program must be executed from the beginning.

- **Axis control by the PMC** Movement under PMC axis control cannot be controlled by this function.

Signal

Check mode signal MMOD <G067#2>

[Classification] Input signal

[Function] This signal enables and disables check mode.

[Operation] When this signal is set to 0, check mode is disabled.
When the signal is set to 1, and the CNC is in MEM mode, check mode is enabled.

Check mode handle valid signal MCHK <G067#3>

[Classification] Input signal

[Function] This signal enables handle operation in check mode.

[Operation] When this signal is set to 0, operation in check mode is equivalent to automatic operation.
When this signal is set to 1, operation in check mode is synchronized with manual handle operation.

**Check mode backward
movement inhibition
signal
MRVM <G067#1>**

[Classification] Input signal

[Function] This signal enables and disables backward movement in check mode.

[Operation] When this signal is set to 0, backward movement is enabled.
When this signal is set to 1, backward movement is disabled.

**Check mode backward
movement signal
MRVMD <F091#0>**

[Classification] Output signal

[Function] This signal posts the check mode backward movement state.

[Output condition] This signal is set to 1 when:

- Operation is in the backward direction.

The signal is set to 0 when:

- Operation is in the forward direction.
-

**Inversion inhibition
signal
MNCHG <F091#1>**

[Classification] Output signal

[Function] This signal posts the inversion inhibition state.

[Output condition] This signal is set to 1 when:

- Switching between forward movement and backward movement is impossible.

The signal is set to 0 when:

- Switching between forward movement and backward movement is possible.
-

**Backward movement
inhibition signal
MRVSP <F091#2>**

[Classification] Output signal

[Function] This signal posts the backward movement inhibition state.

[Output condition] This signal is set to 1 when:

- Backward movement is impossible.

The signal is set to 0 when:

- Backward movement is possible.
-

Signal address

	#7	#6	#5	#4	#3	#2	#1	#0
G067					MCHK	MMOD	MRVM	
F091						MRVSP	MNCHG	MRVMD

Parameter

	#7	#6	#5	#4	#3	#2	#1	#0
6400				HMP	HM8	HM5	HFW	HRP

[Data type] Bit

HRP With the manual handle retrace function, the rapid traverse rate is clamped, assuming that:

0 : An override of 10% is used.

1 : An override of 100% is used.

HFW With the manual handle retrace function, program execution can be performed:

0 : In both forward and backward directions.

1 : Only in the forward direction.

HM5, HM8

HM5	HM8	M code group setting
0	0	Standard (20 groups of four)
1	0	16 groups of five
0	1	10 groups of eight

These parameters set the number of M code groups and the number of M codes in each group.

(See explanations of parameters Nos. 6411 to 6490.)

When 16 groups of five are used, the meanings of parameters are changed as follows:

Group A No.6411(1) to No.6415(5)

Group B No.6416(1) to No.6420(5)

:

Group P No.6486(1) to No.6490(5)

When 10 groups of eight are used, they are changed as follows:

Group A No.6411(1) to No.6418(8)

Group B No.6419(1) to No.6426(8)

:

Group J No.6483(1) to No.6490(8)

HMP When reverse or backward movement is disabled for a path:

0 : Reverse or backward movement is not disabled for other paths.

1 : Reverse or backward movement is also disabled for other paths.

6410	Travel distance per pulse generated from the manual pulse generator for the manual handle retrace function
------	--

[Data type] Byte

[Unit of data] 1%

[Valid data range] 0 to 100

This parameter sets the travel distance per pulse generated from the manual pulse generator for the manual handle retrace function.

This function moves (or dwells) the tool by ([this parameter setting] × [handle magnification])/[pulse of manual pulse generator]).

6411	M code (1) in group A for backward movement by the manual handle retrace function
6412	M code (2) in group A for backward movement by the manual handle retrace function
6413	M code (3) in group A for backward movement by the manual handle retrace function
6414	M code (4) in group A for backward movement by the manual handle retrace function
6415	M code (1) in group B for backward movement by the manual handle retrace function
6416	M code (2) in group B for backward movement by the manual handle retrace function
6417	M code (3) in group B for backward movement by the manual handle retrace function
6418	M code (4) in group B for backward movement by the manual handle retrace function
6419	M code (1) in group C for backward movement by the manual handle retrace function
6420	M code (2) in group C for backward movement by the manual handle retrace function
6421	M code (3) in group C for backward movement by the manual handle retrace function
6422	M code (4) in group C for backward movement by the manual handle retrace function
6423	M code (1) in group D for backward movement by the manual handle retrace function
6424	M code (2) in group D for backward movement by the manual handle retrace function

6425	M code (3) in group D for backward movement by the manual handle retrace function
6426	M code (4) in group D for backward movement by the manual handle retrace function
6427	M code (1) in group E for backward movement by the manual handle retrace function
6428	M code (2) in group E for backward movement by the manual handle retrace function
6429	M code (3) in group E for backward movement by the manual handle retrace function
6430	M code (4) in group E for backward movement by the manual handle retrace function
6431	M code (1) in group F for backward movement by the manual handle retrace function
6432	M code (2) in group F for backward movement by the manual handle retrace function
6433	M code (3) in group F for backward movement by the manual handle retrace function
6434	M code (4) in group F for backward movement by the manual handle retrace function
6435	M code (1) in group G for backward movement by the manual handle retrace function
6436	M code (2) in group G for backward movement by the manual handle retrace function
6437	M code (3) in group G for backward movement by the manual handle retrace function
6438	M code (4) in group G for backward movement by the manual handle retrace function
6439	M code (1) in group H for backward movement by the manual handle retrace function
6440	M code (2) in group H for backward movement by the manual handle retrace function
6441	M code (3) in group H for backward movement by the manual handle retrace function
6442	M code (4) in group H for backward movement by the manual handle retrace function

6443	M code (1) in group I for backward movement by the manual handle retrace function
6444	M code (2) in group I for backward movement by the manual handle retrace function
6445	M code (3) in group I for backward movement by the manual handle retrace function
6446	M code (4) in group I for backward movement by the manual handle retrace function
6447	M code (1) in group J for backward movement by the manual handle retrace function
6448	M code (2) in group J for backward movement by the manual handle retrace function
6449	M code (3) in group J for backward movement by the manual handle retrace function
6450	M code (4) in group J for backward movement by the manual handle retrace function
6451	M code (1) in group K for backward movement by the manual handle retrace function
6452	M code (2) in group K for backward movement by the manual handle retrace function
6453	M code (3) in group K for backward movement by the manual handle retrace function
6454	M code (4) in group K for backward movement by the manual handle retrace function
6455	M code (1) in group L for backward movement by the manual handle retrace function
6456	M code (2) in group L for backward movement by the manual handle retrace function
6457	M code (3) in group L for backward movement by the manual handle retrace function
6458	M code (4) in group L for backward movement by the manual handle retrace function
6459	M code (1) in group M for backward movement by the manual handle retrace function
6460	M code (2) in group M for backward movement by the manual handle retrace function

6461	M code (3) in group M for backward movement by the manual handle retrace function
6462	M code (4) in group M for backward movement by the manual handle retrace function
6463	M code (1) in group N for backward movement by the manual handle retrace function
6464	M code (2) in group N for backward movement by the manual handle retrace function
6465	M code (3) in group N for backward movement by the manual handle retrace function
6466	M code (4) in group N for backward movement by the manual handle retrace function
6467	M code (1) in group O for backward movement by the manual handle retrace function
6468	M code (2) in group O for backward movement by the manual handle retrace function
6469	M code (3) in group O for backward movement by the manual handle retrace function
6470	M code (4) in group O for backward movement by the manual handle retrace function
6471	M code (1) in group P for backward movement by the manual handle retrace function
6472	M code (2) in group P for backward movement by the manual handle retrace function
6473	M code (3) in group P for backward movement by the manual handle retrace function
6474	M code (4) in group P for backward movement by the manual handle retrace function
6475	M code (1) in group Q for backward movement by the manual handle retrace function
6476	M code (2) in group Q for backward movement by the manual handle retrace function
6477	M code (3) in group Q for backward movement by the manual handle retrace function
6478	M code (4) in group Q for backward movement by the manual handle retrace function

6479	M code (1) in group R for backward movement by the manual handle retrace function
6480	M code (2) in group R for backward movement by the manual handle retrace function
6481	M code (3) in group R for backward movement by the manual handle retrace function
6482	M code (4) in group R for backward movement by the manual handle retrace function
6483	M code (1) in group S for backward movement by the manual handle retrace function
6484	M code (2) in group S for backward movement by the manual handle retrace function
6485	M code (3) in group S for backward movement by the manual handle retrace function
6486	M code (4) in group S for backward movement by the manual handle retrace function
6487	M code (1) in group T for backward movement by the manual handle retrace function
6488	M code (2) in group T for backward movement by the manual handle retrace function
6489	M code (3) in group T for backward movement by the manual handle retrace function
6490	M code (4) in group T for backward movement by the manual handle retrace function

[Data type] Word

[Unit of data] 0 to 9999

These parameters set the M codes in each group for backward movement by the manual handle retrace function.

For backward movement for an M code, the modal M code in the same group set by the parameter is output. The first M code in each group is set as the default at a reset.

When the number of M codes in a group is 3 or less, set the parameter corresponding to an unused M code to 0.

(For backward movement for “M0”, “M0” is output regardless of which M code is set for the parameter.)

For an M code which is not set in any group by any of the above parameters, the M code for forward movement is output.

In the M codes set as the same group by above parameters, only the first M code in each block can be output for backward movement. When a block contains two or more M codes, as the second and subsequent M codes, the same M codes as output for forward movement are output.

CAUTION

The above explanation of M code groups assumes that the standard setting is made. The number of M codes for each group and the number of M code groups vary depending on bits 2 (HM5) and 3 (HM8) of parameter No. 6400.

Caution**CAUTION**

- 1 This function is optional and is available only in lathe systems. In addition to this function, the following option is required:
 - Manual singles-handle control
- 2 This function cannot be used with the following functions:
 - Advanced preview control
 - Angular axis control
 - Angular axis control for an arbitrary axis

5.4 MANUAL ABSOLUTE ON/OFF

General

This function selects whether the movement of the tool with manual operation (such as jog feed and manual handle feed) is counted for calculating the current position in the workpiece coordinate system. A check signal is also output to indicate whether the manual absolute function in the CNC is turned on or off.

When manual absolute turns on (manual absolute signal *ABSM =0)

When manual operation interrupts during automatic operation:

- i) At the end of the block where manual operation interrupts, the tool position moves in parallel by the manual move amount, regardless of the absolute or incremental command.
- ii) In subsequent blocks, the parallel-moved tool position remains unchanged until an absolute command block appears. Therefore, if all blocks are programmed by incremental commands, the tool keeps the parallel-moved position until machining ends.

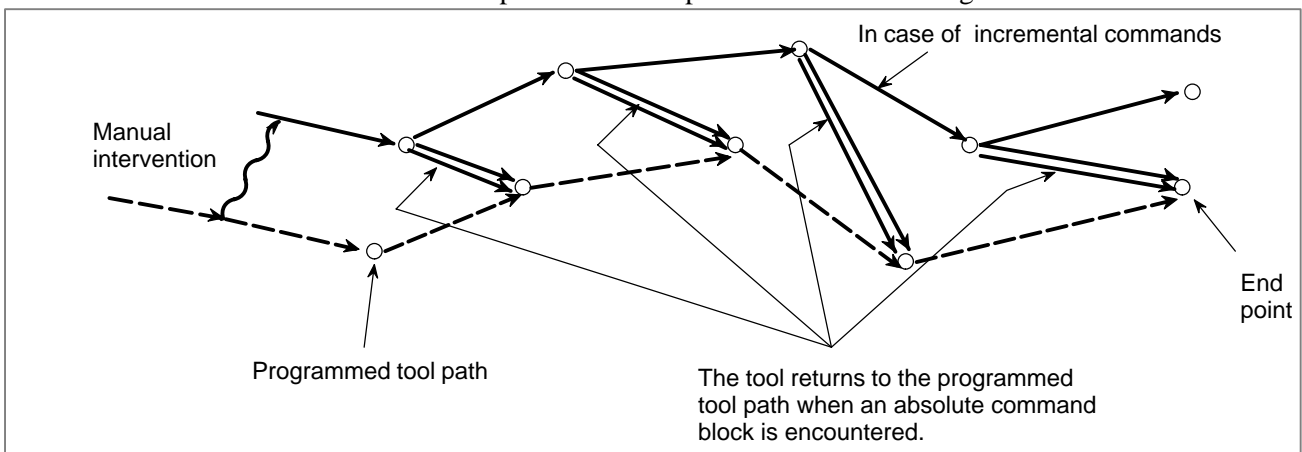

Fig. 5.4 (a) Manual absolute ON

CAUTION

If the machining end position has shifted by the manual move amount because all blocks are programmed by incremental commands only, the present position is displayed shifted by the manual move amount.

When manual absolute turns off (manual absolute signal *ABSM=1)

The manual move amount is not counted to the present position on the workpiece coordinate system. The present position display on the CRT includes the manual move amount. The display is reset to the initial value (before manual operation) when the control is reset, or when operation in the automatic operation mode MEM, RMT, or MDI is started after the manual operation.

During automatic operation, if manual intervention of a block interrupts, the tool position moves in parallel by the manual move amount, regardless of the absolute or incremental command at the end point of that block, as well as at the end point of subsequent blocks.

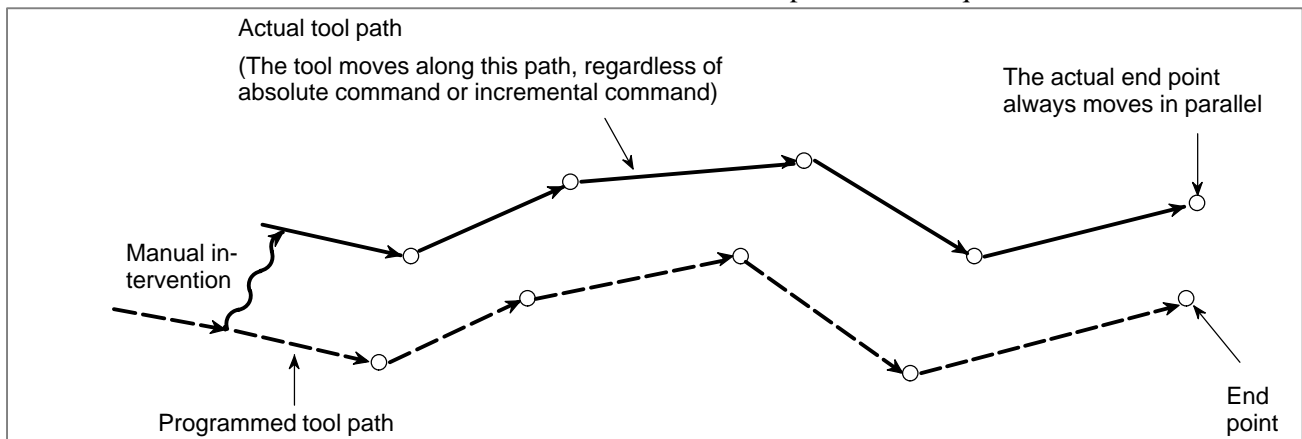

Fig. 5.4 (b) Manual absolute OFF

The present position display at the finish of the operation shows an end point value on the program as if manual intervention had not been executed. However, the tool position moves in parallel.

Signal

Manual absolute signal

***ABSM <G006#2>**

[Classification] Input signal

[Function] Turns the manual absolute function on or off.

[Operation] When this signal is set to 1, the control unit operates as follows:

- Turns off the manual absolute function.

When this signal is set to 0, the control unit operates as follows:

- Turns on the manual absolute function.

**Manual absolute check
signal
MABSM
<F004#2>**

[Classification] Output signal

[Function] Notifies the PMC of the state of the manual absolute signal.

[Output condition] This signal is set to 1 in the following case:

- When the manual absolute signal *ABSM is set to 0

This signal is set to 0 in the following case:

- When manual absolute signal *ABSM is set to 1

Signal address

	#7	#6	#5	#4	#3	#2	#1	#0
G006						*ABSM		
F004						MABSM		

Reference item

Series 16i/18i/160i/180i/ 160is/180is	OPERATOR'S MANUAL (For Machining Center) (B-63534EN)	III.3.5	Manual absolute ON/OFF
	OPERATOR'S MANUAL (For Lathe) (B-63524EN)	III.3.5	Manual absolute ON/OFF
Series 21i/210i/210is	OPERATOR'S MANUAL (For Machining Center) (B-63614EN)	III.3.5	Manual absolute ON/OFF
	OPERATOR'S MANUAL (For Lathe) (B-63604EN)	III.3.5	Manual absolute ON/OFF
Series 20i	OPERATOR'S MANUAL (For Manual Milling Machine) (B-64204EN)	III.3.5	Manual absolute ON/OFF
	OPERATOR'S MANUAL (For Manual Lathes) (B-64194EN)	III.3.5	Manual absolute ON/OFF

5.5 OPTIONAL BLOCK SKIP/ADDITION OF OPTIONAL BLOCK SKIP

General

When a slash followed by a number (/n, where n = 1 to 9) is specified at the head of a block, and optional block skip signals BDT1 to BDT9 are set to 1 during automatic operation, the information contained in the block for which /n, corresponding to signal BDTn, is specified is ignored (from /n to the end of the block).

(Example) /2 N123 X100. Y200. ;

Input signal	Code specified at the head of a block
BDT1	/ or /1 (Note 1)
BDT2	/2
BDT3	/3
BDT4	/4
BDT5	/5
BDT6	/6
BDT7	/7
BDT8	/8
BDT9	/9

NOTE

1 Number 1 for /1 can be omitted. However, when two or more optional block skip switches are used in one block, number 1 for /1 cannot be omitted.

(Example)

//3 N123 X100. Y200. ; — Invalid
/1 /3 N123 X100. Y200. ; — Valid

The following figures show the relationship between the timing, when optional block skip signals (BDT1 to BDT9) are set to 1, and the ignored information:

1. When BDTn is set to 1 before the CNC starts reading a block containing /n, the block is ignored.

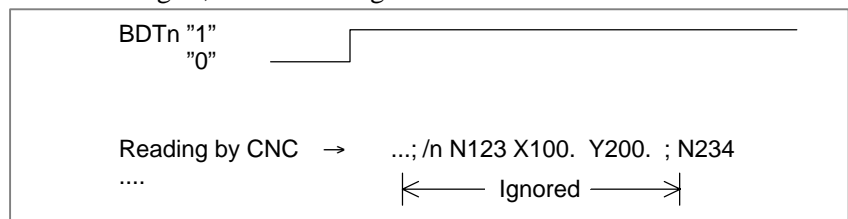

2. When BDTn is set to 1 while the CNC is reading a block containing /n, the block is not ignored.

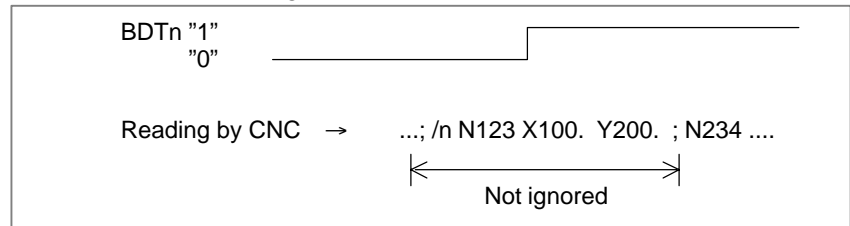

3. When BDTn, currently set to 1, is set to 0 while the CNC is reading a block containing /n, the block is ignored.

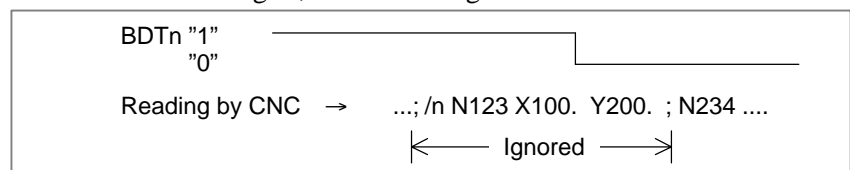

4. When two or more optional block skip switches are specified in a block and BDTn, corresponding to one of them, is set to 1, the block is ignored.

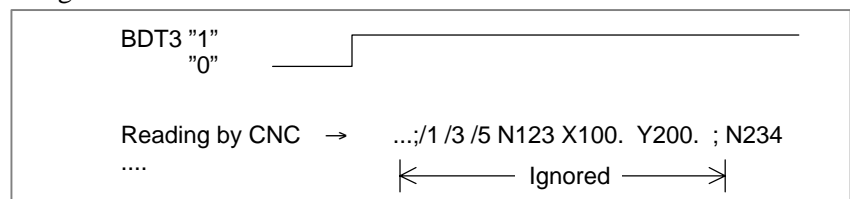

Signal

Optional block skip signals

BDT1 <G044#0>

BDT2 to BDT9 <G045>

[Classification] Input signal

[Function] Select whether a block containing /n is to be executed or ignored.

[Operation] During automatic operation, a block containing /n in the program is ignored when the corresponding optional block skip signal is set to 1. It is executed normally when the signal is set to 0.

**Optional block skip
check signals
MBDT1 <F004#0>
MBDT2 to MBDT9
<F005>**

[Classification] Output signal

[Function] Notify the PMC of the states of the optional block skip signals BDT1 to BDT9. Nine signals are provided, corresponding to the nine optional block skip signals. Signal MBDTn corresponds to signal BDTn.

[Output condition] Signal MBDTn is set to 1 in the following case:

- When the corresponding optional block skip signal (BDTn) is set to 1

Signal MBDTn is set to 0 in the following case:

- When the corresponding optional block skip signal (BDTn) is set to 0

Signal address

	#7	#6	#5	#4	#3	#2	#1	#0
G044								BDT1
G045	BDT9	BDT8	BDT7	BDT6	BDT5	BDT4	BDT3	BDT2
F004								MBDT1
F005	MBDT9	MBDT8	MBDT7	MBDT6	MBDT5	MBDT4	MBDT3	MBDT2

Note

NOTE

- 1 This function is ignored when programs are loaded into memory. Blocks containing /n are also stored in memory, regardless of how the optional block skip signal is set. Programs stored in memory can be output, regardless of how the optional block skip signals are set. Optional block skip is effective even during sequence number search operation.
- 2 Position of a slash
A slash (/) must be specified at the head of a block. If a slash is placed elsewhere, the information from the slash to immediately before the EOB code is ignored.
- 3 TV and TH check
When an optional block skip signal is "1". TH and TV checks are made for the skipped portions in the same way as when the optional block skip switch is "0".

Reference item

Series 16 <i>i</i> /18 <i>i</i> /160 <i>i</i> /180 <i>i</i> / 160 <i>is</i> /180 <i>is</i>	OPERATOR'S MANUAL (For Machining Center) (B-63534EN)	II.12.2	Program section configuration
	OPERATOR'S MANUAL (For Lathe) (B-63524EN)	II.12.2	Program section configuration
Series 21 <i>i</i> /210 <i>i</i> /210 <i>is</i>	OPERATOR'S MANUAL (For Machining Center) (B-63614EN)	II.12.2	Program section configuration
	OPERATOR'S MANUAL (For Lathe) (B-63604EN)	II.12.2	Program section configuration
Series 20 <i>i</i>	OPERATOR'S MANUAL (For Manual Milling Machine) (B-64204EN)	II.12.2	Program section configuration
	OPERATOR'S MANUAL (For Manual Lathes) (B-64194EN)	II.12.2	Program section configuration

5.6 SEQUENCE NUMBER COMPARISON AND STOP

General

During program execution, this function causes a single block stop right after a block with a specified sequence number is executed.

To use this function, first specify the program number (1 to 9999) of a program that contains a sequence number where operation is to be stopped and the sequence number on the setting data screen:

With this setting, a single block stop occurs after the execution of the block with the specified sequence number during automatic operation.

Parameter

Setting data

- SEQUENCE STOP (PROGRAM NO.)
Specify the program number (1 to 9999) of a program to which a sequence to be stopped belongs.
- SEQUENCE STOP (SEQUENCE NO.)
Specify the sequence number (1 to 99999) of a sequence to be stopped.

Note

NOTE

After the specified sequence number is found during the execution of the program, the sequence number set for sequence number compensation and stop is decremented by one. When the power is turned on, the setting of the sequence number is 0.

Reference item

Series 16i/18i/160i/180i/ 160is/180is	OPERATOR'S MANUAL (For Machining Center) (B-63534EN)	III.11.4.4	Sequence Number Comparison and Stop
	OPERATOR'S MANUAL (For Lathe) (B-63524EN)	III.11.4.8	Sequence Number Comparison and Stop
Series 21i/210i/210is	OPERATOR'S MANUAL (For Machining Center) (B-63614EN)	III.11.4.4	Sequence Number Comparison and Stop
	OPERATOR'S MANUAL (For Lathe) (B-63604EN)	III.11.4.8	Sequence Number Comparison and Stop

5.7 PROGRAM RESTART

General

A program may be restarted at a block by specifying the sequence number of the block, after automatic operation is stopped because of a broken tool or for holidays. This function can also be used as a high-speed program check function.

There are two types of restart methods.

P type: Restart after a tool is broken down

Q type: Restart after holidays

Signal

Program restart signal SRN<G006#0>

[Classification] Input signal

[Function] Selects program restart.

[Operation] When the program restart signal is set to “1” to search for the sequence number of the block to be restarted, the CRT screen changes to the program restart screen. When the program restart signal is set to “0”, and automatic operation is activated, the tool is moved back to the machining restart point at dry run speed along the axes one by one in the sequence specified in parameter No. 7310. When the tool is set to the restart point, machining restarts.

Program restart under way signal SRNMV<F002#4>

[Classification] Output signal

[Function] Indicates the program is being restarted.

[Output condition] The program restart under way signal becomes “1” when:

- The program restart signal is set to “0” after the CRT screen changes to the program restart screen.

The signal is set to “0” when:

- The program restart sequence ends (the tool has been moved to the restart point on all controlled axes).

Signal address

	#7	#6	#5	#4	#3	#2	#1	#0
G006								SRN
F002				SRNMV				

Parameter

7310	Movement sequence to program restart position
------	---

Setting entry is accepted.

[Data type] Byte axis

[Valid data range] 1 to no. of controlled axes

This parameter sets the axis sequence when the machine moves to the restart point by dry run after a program is restarted.

[Example]

The machine moves to the restart point in the order of the fourth, first, second, and third axes one at a time when the first axis = 2, the second axis = 3, the third axis = 4, and the fourth axis = 1 are set.

Alarm and message

Number	Message	Description
094	P TYPE NOT ALLOWED (COORD CHG)	P type cannot be specified when the program is restarted. (After the automatic operation was interrupted, the coordinate system setting operation was performed.) Perform the correct operation according to the operator's manual.
095	P TYPE NOT ALLOWED (EXT OFS CHG)	P type cannot be specified when the program is restarted. (After the automatic operation was interrupted, the external workpiece offset amount changed.)
096	P TYPE NOT ALLOWED (WRK OFS CHG)	P type cannot be specified when the program is restarted. (After the automatic operation was interrupted, the workpiece offset amount changed.)
097	P TYPE NOT ALLOWED (AUTO EXEC)	P type cannot be specified when the program is restarted. (After power ON, after emergency stop or P / S alarm 94 to 97 were reset, no automatic operation was performed.) Perform automatic operation.
098	G28 FOUND IN SEQUENCE RETURN	A command of the program restart was specified without the reference position return operation after power ON or emergency stop, and G28 was found during search. Perform the reference position return.
099	MDI EXEC NOT ALLOWED AFT. SEARCH	After completion of search in program restart, a move command is given with MDI.

Warning

WARNING

As a rule, the tool cannot be returned to a correct position under the following conditions.

Special care must be taken in the following cases since none of them cause an alarm:

- Manual operation is performed when the manual absolute mode is OFF.
- Manual operation is performed when the machine is locked.
- When the mirror image is used.
- When manual operation is performed in the course of axis movement for returning operation.
- When the program restart is commanded for a block between the block for skip cutting and subsequent absolute command block.
- When program restart specified for an intermediate block for a multiple repetitive canned cycle

Reference item

Series 16i/18i/160i/180i/ 160is/180is	OPERATOR'S MANUAL (For Machining Center) (B-63534EN)	III.4.5	PROGRAM RESTART
	OPERATOR'S MANUAL (For Lathe) (B-63524EN)	III.4.3	PROGRAM RESTART
Series 21i/210i/210is	OPERATOR'S MANUAL (For Machining Center) (B-63614EN)	III.4.4	PROGRAM RESTART
	OPERATOR'S MANUAL (For Lathe) (B-63604EN)	III.4.3	PROGRAM RESTART
Series 20i	OPERATOR'S MANUAL (For Manual Milling Machine) (B-64204EN)	III.4.4	PROGRAM RESTART

5.8 TOOL RETRACTION AND RETURN

General

The tool can be retracted from a workpiece to replace the tool, if damaged during machining, or to check the status of machining. Then, the tool can be returned to restart machining efficiently.

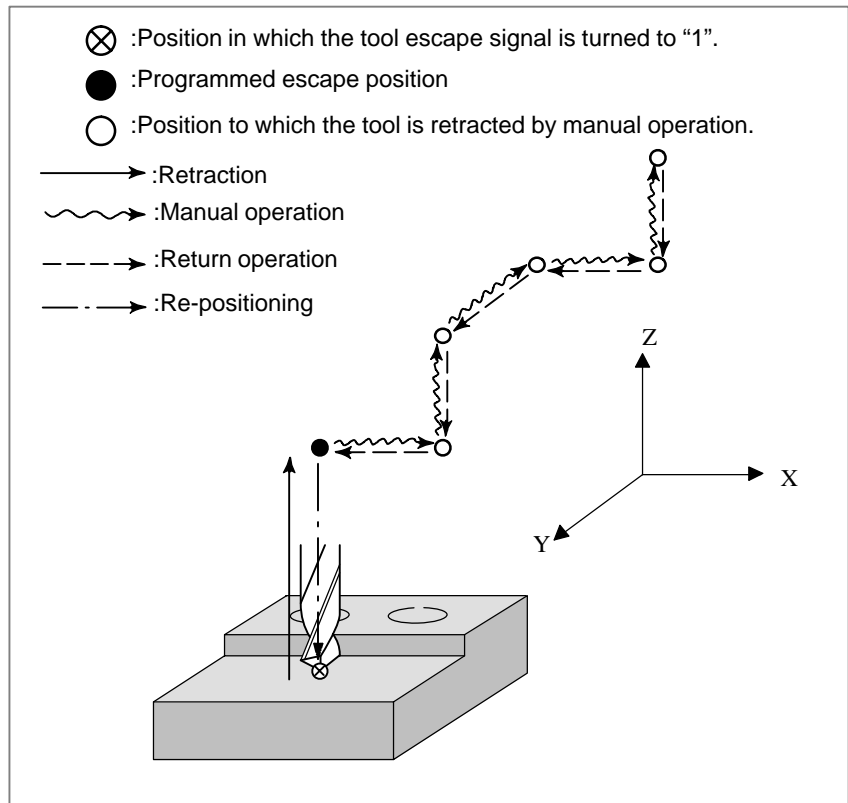
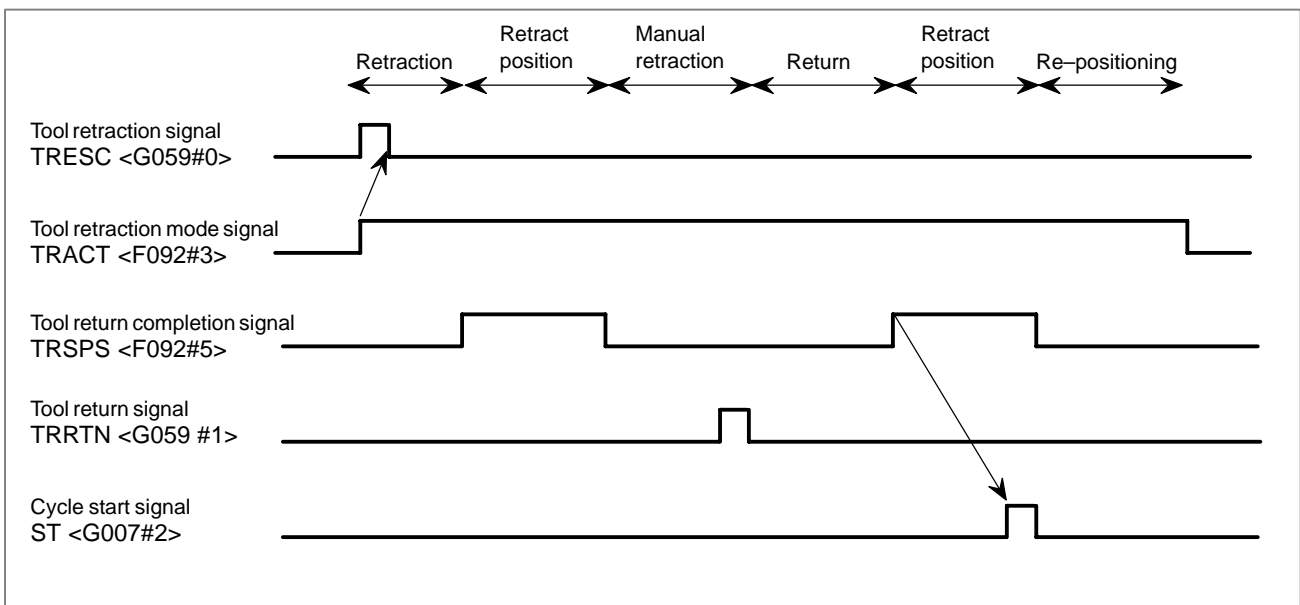

Fig. 5.8 Path of tool retraction and return for M series

Basic procedure for tool retraction and return

- When tool retraction signal TRES input from the PMC turned to "1" while automatic operation is started, stopped, or held, the tool is retracted by the distance specified in the program. The position to which the tool retracts is called the retraction position. When TRES turned to "1" while automatic operation is started, if a block is being executed, the tool is retracted after the block is suspended. When retraction ends, the machine enters the automatic operation hold state. The clearance and direction can be specified by the program. If these values are not specified by the program, the tool is not retracted. When TRES turns to "1", the machine enters the tool retraction mode, and tool retraction mode signal TRACT turns to "1" to notify the PMC that the machine has entered the tool retraction mode.

- In the manual mode, when it is necessary to replace the tool or measure workpieces, the tool can be moved manually, such as by manual continuous feed, or manual handle feed. This operation is called manual retraction. The path along which the tool retracts is automatically stored in the control unit. The number of paths which can be stored, however, is limited.
- Set automatic operation mode again. Set the tool return signal TRRTN to 1, then to 0. Then, the control unit traces back the path of the manually moved tool to automatically return the tool to the retract position. This operation is called return. When the tool has been returned to the retraction position, tool retraction completion signal TRSPS is turned to “1”.
- When the automatic operation is started at the retraction position, the tool is first returned to the position where TRESA was turned to “1”. This operation is called repositioning. When repositioning completes, TRACT is turned to “0” to notify the PMC of the end of the tool retraction mode. Then the operation differs according to the status of automatic operation when the machine entered the tool retraction mode.
 - When the machine enters the tool retraction mode while automatic operation is started, the automatic operation that has been held is resumed after the tool is repositioned.
 - When the machine enters the tool retraction mode while automatic operation is stopped or held, the machine returns to the same mode after the tool is repositioned. If the cycle is restarted, automatic operation is resumed.



Signal

Tool retraction signal TRES<G059#0>

[Classification] Input signal

[Function] Tool retraction mode is selected.

[Operation] When this signal is turned to 1, the control unit retracts the tool by a pre-programmed distance.

Tool retraction mode signal TRACT<F092#3>

[Classification] Output signal

[Function] This signal reports that tool retraction mode is set. When the control unit is reset while the signal is 1, the signal is turned to 0, and tool retraction mode is canceled.

[Output condition] The signal is turned to “1” when:

- Tool retraction mode is selected.

The signal is turned to “0” when:

- Tool retraction mode is not selected.

Tool return signal TRRTN<G059#1>

[Classification] Input signal

[Function] In tool retraction mode, a tool that has been retracted manually along an axis is returned to the retract position along the same axis.

[Operation] When this signal is turned to “1”, the control unit traces back the path of the manually moved tool to automatically return the tool to the retract position.

Tool return completion signal TRSPS<F092#5>

[Classification] Output signal

[Function] This signal reports that the tool is in the retract position in tool retraction mode. When this signal is “0”, re-positioning cannot be performed by pressing the cycle start button.

[Output condition] The signal is set to “1” when:

- Retraction has been completed.
- The tool has been returned to the retract position.

The signal is set to “0” when:

- The tool is not in the retract position in tool retraction mode.

Signal address

	#7	#6	#5	#4	#3	#2	#1	#0
G059							TRRTN	TRESC
	#7	#6	#5	#4	#3	#2	#1	#0
F092			TRSPS		TRACT			

Warning

WARNING

The retraction axes and retraction distances specified with G10.6 need to be changed in appropriate blocks depending on the figure to be machined. An incorrectly specified retraction distance may damage a workpiece, the machine, or the tool. So, be very careful when specifying a retraction distance.

Reference item

Series 16i/18i/160i/180i/ 160is/180is	OPERATOR'S MANUAL (For Machining Center) (B-63534EN)	III. 4.10	Tool Retraction and Return
	OPERATOR'S MANUAL (For Lathe) (B-63524EN)	III. 19.7	Tool Retraction and Return

5.9 EXACT STOP/ EXACT STOP MODE/ TAPPING MODE/ CUTTING MODE (M SERIES)

General

NC commands can be used to control a feedrate in continuous cutting feed blocks as described below.

- **Exact stop (G09)**

The tool is decelerated in a block specifying G09, and an in-position check (*1) is performed. When the feed motor falls in-position, the tool is moved by the next block. This function may be used to produce a sharp edge at the corner of a workpiece.

- **Exact Stop Mode (G61)**

When G61 is commanded, deceleration of cutting feed command at the end point and inposition check is performed per block thereafter. This G61 is valid until G62 (automatic corner override), G63 (tapping mode), or G64 (cutting mode), is commanded.

- **Tapping Mode (G63)**

When G63 is commanded, feed rate override is ignored (always regarded as 100%), and feed hold also becomes invalid. Cutting feed does not decelerate at the end of block to transfer to the next block. This G63 is valid until G61 (exact stop mode), G62 (automatic corner override), or G64 (cutting mode) is commanded.

- **Cutting Mode (G64)**

When G64 is commanded, deceleration at the end point of each block thereafter is not performed and cutting goes on to the next block. This command is valid until G61 (exact stop mode), G62 (automatic corner override), or G63 (tapping mode) is commanded.

However, in G64 mode, feed rate is decelerated to zero and in-position check is performed in the following case;

- 1) Positioning mode (G00, G60)
- 2) Block with exact stop check (G09)
- 3) Next block is a block without movement command

*1 The term in-position indicates that the servo motor reaches in a range of positions specified by a parameter. See Section 7.2.6.1 and 7.2.6.2 for details.

(Example) Tool paths from block (1) to block (2)

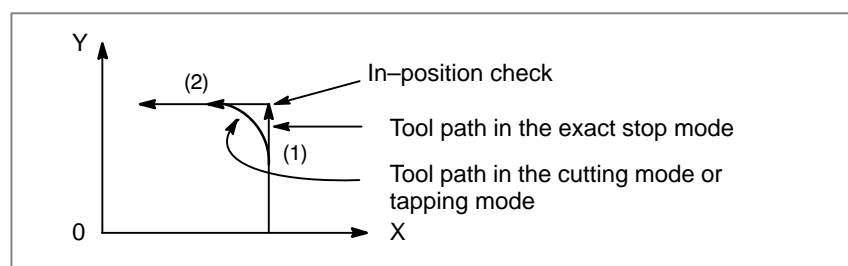

Reference item

Series 16 <i>i</i> /18 <i>i</i> /160 <i>i</i> /180 <i>i</i> / 160 <i>is</i> /180 <i>is</i>	OPERATOR'S MANUAL (For Machining Center) (B-63534EN)	II.5.4.1	Exact Stop (G09, G61) Cutting Mode (G64) Tapping Mode (G63)
Series 21 <i>i</i> /210 <i>i</i> /210 <i>is</i>	OPERATOR'S MANUAL (For Machining Center) (B-63614EN)	II.5.4.1	Exact Stop (G09, G61) Cutting Mode (G64) Tapping Mode (G63)
Series 20 <i>i</i>	OPERATOR'S MANUAL (For Manual Milling Machine) (B-64204EN)	II.5.4.1	Exact Stop (G09, G61) Cutting Mode (G64) Tapping Mode (G63)

5.10 BALANCE CUT (2-PATH CONTROL FOR T SERIES)

General

When a thin workpiece is to be machined as shown in fig. 5.10, a precision machining can be achieved by machining each side of the workpiece with a tool simultaneously; this function can prevent the workpiece from distortion that results when only one side is machined at a time. When both sides are machined at the same time, the movement of one tool must synchronize with that of the other tool. Otherwise, the workpiece may vibrate, resulting in poor machining. With this function, the movement of one tool post can easily synchronize with that of the other tool post.

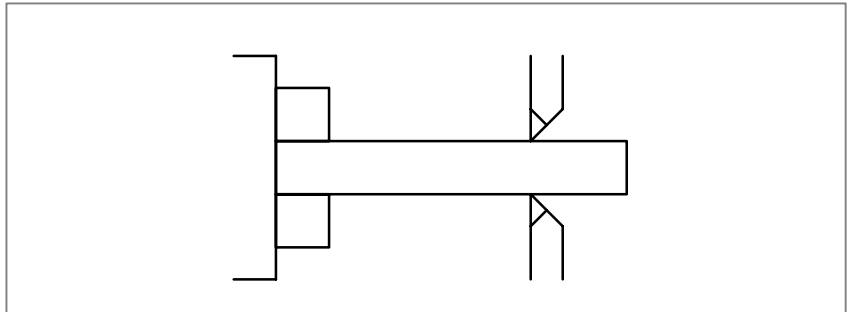

Fig. 5.10 Balance cut

Alarm and message

No.	Message	Contents
163	COMMAND G68/G69 INDEPENDENTLY (T series 2-path control)	G68 and G69 are not independently commanded in balance cut. Correct program.

Caution**CAUTION**

- 1 If feed hold operation is performed during balance cutting using both tool posts, balance cut processing is not performed at restart time, it is performed when the next move command is specified for both tool posts.
- 2 Balance cutting is not performed in dry run or machine lock state.
- 3 When rapid traverse operation is specified, balance cut processing is not performed.
- 4 A workpiece for which thread cutting has been performed in the balance cut mode cannot be subjected to thread cutting in the cancel mode. Thread cutting starts at a different position.
- 5 Balance cut only starts cutting feed on both tool posts at the same time; it does not maintain synchronization thereafter. To synchronize all the movements of both tool posts, the data for both tool posts, such as the travel distance and feedrate, must be the same.

Note**NOTE**

- 1 Time delay before the pulse distribution of both tool posts is started is 2 ms or shorter.
- 2 In the balance cut mode, synchronization is established at the start of a move block, so movement may momentarily stop.
- 3 The cancel mode (G69) is set by a reset.
- 4 When the option "mirror image for double turrets" is selected, the balance cut function cannot be used.

Reference item

Series 16i/18i/160i/180i/ 160is/180is	OPERATOR'S MANUAL (For Lathe) (B-63524EN)	II. 20.4	Balance Cut (G68, G69)
---	--	----------	------------------------

5.11 DNC OPERATION

General

By starting automatic operation during the DNC operation mode (RMT), it is possible to perform machining (DNC operation) while a program is being read from the remote buffer or memory card.

If the floppy cassette directory display option is available, it is possible to select files (programs) saved in an external input/output unit of a floppy format (Handy File, Floppy Cassettes, or FA card) and specify (schedule) the sequence and frequency of execution for automatic operation.

To use the DNC operation function, it is necessary to set the parameters related to the reader/puncher interface, and remote buffer in advance.

Signal

DNC operation select signal DNCI<G043#5>

[Classification] Input signal

[Function] Selects the DNC operation mode (RMT).

To select the DNC operation mode (RMT), it is necessary to select the memory operation mode (MEM) and set the DNC operation select signal to "1".

[Operation] When the DNC operation select signal becomes "1", the control unit operates as follows:

- If the memory mode (MEM) has not been selected, the signal is ignored, and nothing happens.
- If the memory operation mode (MEM) has been selected, the DNC operation mode (RMT) is selected, and DNC operation becomes possible. In this case, the DNC operation selection confirm signal MRMT becomes "1".

DNC operation selection confirm signal MRMT<F003#4>

[Classification] Output signal

[Function] Indicates that the DNC operation mode (RMT) has been selected.

[Output condition] The DNC operation selection confirm signal becomes "1" when:

- The DNC operation mode (RMT) is selected.

The DNC operation selection confirm signal becomes "0" when:

- The DNC operation mode (RMT) is not selected.

Signal address

	#7	#6	#5	#4	#3	#2	#1	#0
G043			DNCI					
	#7	#6	#5	#4	#3	#2	#1	#0
F003				MRMT				

Parameter

	#7	#6	#5	#4	#3	#2	#1	#0
0100			ND3					

Setting entry is accepted.

[Data type] Bit

ND3 In DNC operation, a program is:

0 : Read block by block. (A “DC3” code is output for each block.)

1 : Read continuously until the buffer becomes full. (A “DC3” code is output when the buffer becomes full.)

NOTE

In general, reading is performed more efficiently when ND3=1. This specification reduces the number of buffering interruptions caused by reading of a series of blocks specifying short movements. This reduces the cycle time.

	#7	#6	#5	#4	#3	#2	#1	#0
0138	DNM							

[Data type] Bit

DNM DNC operation with a memory card is:

0 : Disabled.

1 : Enabled. (A PCMCIA card attachment is required separately.)

NOTE

- 1 It is necessary to secure the memory card by using a PCMCIA card attachment suitable for the memory card CNC.
- 2 While DNC operation using a memory card is being performed, display of a directory in the memory card and other operations that access to the memory card cannot be performed.
- 3 In a multipath system, DNC operation using a memory card cannot be performed.
- 4 A set DNC operation file name is erased at power-off.
- 5 During DNC operation using a memory card, do not remove or insert the memory card.
- 6 A program executed in DNC operation cannot call a program stored on the memory card.

Alarm and message

Number	Message	Description
086	DR SIGNAL OFF	When entering data in the memory by using Reader / Puncher interface, the ready signal (DR) of reader / puncher was off. Power supply of I/O unit is off or cable is not connected or a P.C.B. is defective.
123	CAN NOT USE MACRO COMMAND IN DNC	Macro control command is used during DNC operation. Modify the program.
210	CAN NOT COMAND M198/M99	M198 and M99 are executed in the schedule operation. Or M198 is executed in the DNC operation.

Reference item

Series 16i/18i/160i/180i/ 160is/180is	OPERATOR'S MANUAL (For Machining Center) (B-63534EN)	III.4.6	SCHEDULING FUNCTION
	OPERATOR'S MANUAL (For Lathe) (B-63524EN)	III.4.4	SCHEDULING FUNCTION
Series 21i/210i/210is	OPERATOR'S MANUAL (For Machining Center) (B-63614EN)	III.4.5	SCHEDULING FUNCTION
	OPERATOR'S MANUAL (For Lathe) (B-63604EN)	III.4.4	SCHEDULING FUNCTION
Series 20i	OPERATOR'S MANUAL (For Manual Milling Machine) (B-64204EN)	III.4.5	SCHEDULING FUNCTION
CONNECTION MANUAL (This manual)		13.1	READER/PUNCHER INTER- FACE
		13.2	REMOTE BUFFER
		15.6	DIRECT OPERATION BY PMC OPEN CNC

5.12 MANUAL INTERVENTION AND RETURN

General

If the tool movement along the axes is stopped by a feed hold during automatic operation, then restarted after manual intervention such as tool exchange, the tool moves back to the point of intervention before automatic operation is resumed.

This function is easy to operate because unlike the program restart function or the tool retract and restore function, it is unnecessary to operate switches on the operator's panel or MDI keys.

Parameter

	#7	#6	#5	#4	#3	#2	#1	#0
7001								MIN

[Data type] Bit

MIN The manual intervention and return function is:

0 : Disabled.

1 : Enabled.

Warning

WARNING

If you do not make manual intervention correctly according to the direction of machining and the shape of the workpiece, the machine and tool may be broken down. Use sufficient care.

Reference item

Series 16i/18i/160i/180i/ 160is/180is	OPERATOR'S MANUAL (For Machining Center) (B-63534EN)	III.4.12	MANUAL INTERVENTION AND RETURN
	OPERATOR'S MANUAL (For Lathe) (B-63524EN)	III.4.8	MANUAL INTERVENTION AND RETURN
Series 21i/210i/210is	OPERATOR'S MANUAL (For Machining Center) (B-63614EN)	III.4.9	MANUAL INTERVENTION AND RETURN
	OPERATOR'S MANUAL (For Lathe) (B-63604EN)	III.4.8	MANUAL INTERVENTION AND RETURN
Series 20i	OPERATOR'S MANUAL (For Manual Milling Machine) (B-64204EN)	III.4.9	MANUAL INTERVENTION AND RETURN
	OPERATOR'S MANUAL (For Manual Lathes) (B-64194EN)	III.4.7	MANUAL INTERVENTION AND RETURN

5.13 RETRACTION FOR RIGID TAPPING (M SERIES)

General

When rigid tapping is stopped, either as a result of an emergency stop or a reset, the tap may cut into the workpiece. The tap can subsequently be drawn out by using a PMC signal. This function automatically stores information relating to the tapping executed most recently. When a tap retraction signal is input, the tap is removed from the hole, based on the stored information. The tap is pulled toward the R point. When a retract value α is set in parameter No. 5382, the retraction distance can be increased by α .

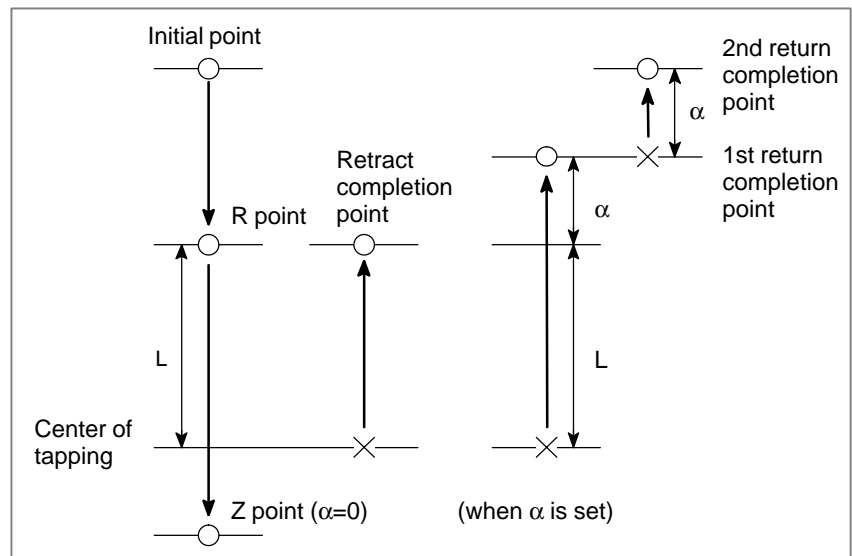

Basic procedure

(1) Start

Reset the CNC, then select MDI mode. Setting rigid tapping retraction start signal RTNT to "1" starts rigid tapping retraction.

(2) Completion

Upon the completion of rigid tapping retraction, rigid tapping retraction completion signal RTPT is set to "1", with which the CNC automatically enters the reset state. Setting rigid tapping retract start signal RTNT to "0" sets rigid tapping retraction completion signal RTPT to "0".

(3) Stop

During rigid tapping retraction, setting rigid tapping retraction start signal RTNT to "0" stops rigid tapping retraction, placing the CNC in the reset state. To resume rigid tapping retraction, set rigid tapping retraction start signal RTNT to "1". Rigid tapping retraction can also be stopped by means of a reset or feed hold.

(4) Resume

Once rigid tapping retraction has been stopped, it can be resumed by performing the same operation as that used for starting rigid tapping retraction. If rigid tapping retraction has been completed, however, the start operation does not restart rigid tapping retraction. If retract value α is set in parameter No. 5382, however, the start operation performs rigid tapping retraction using α only.

Start and completion time chart

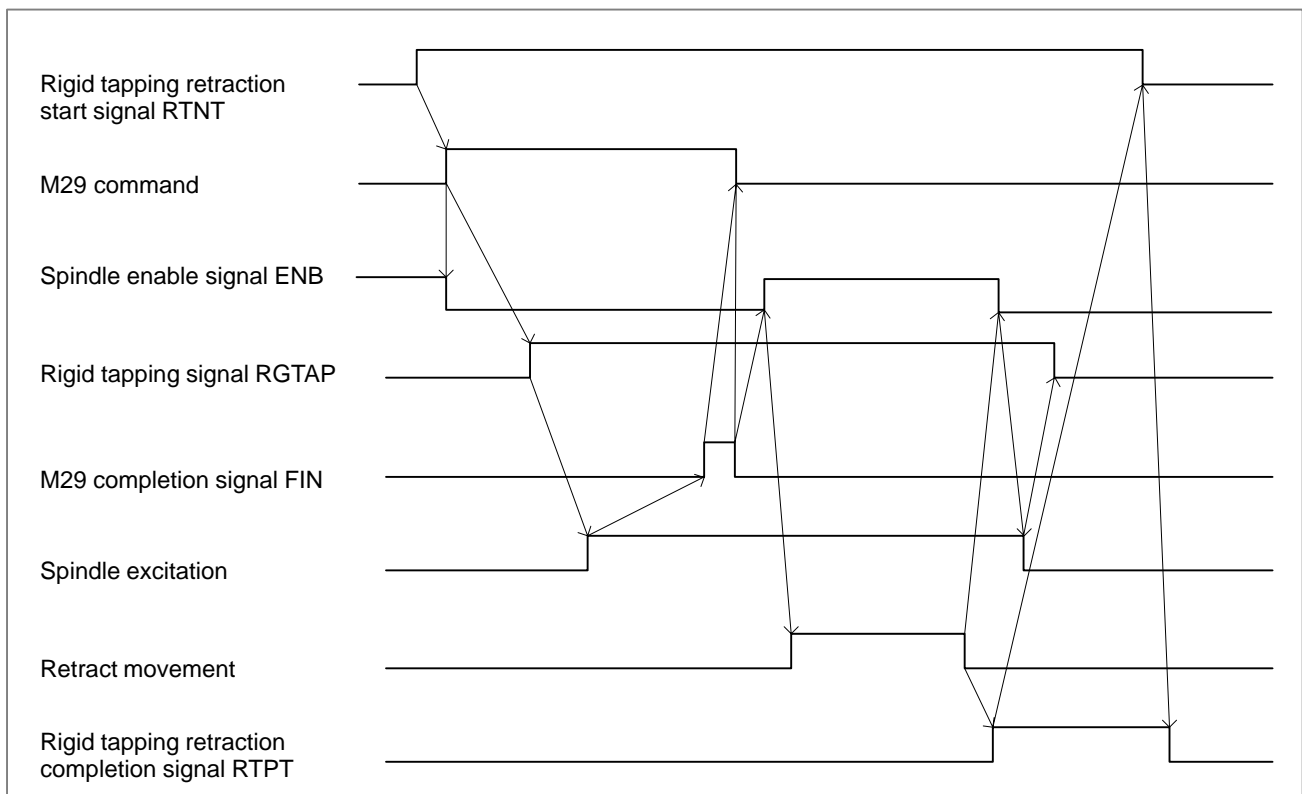
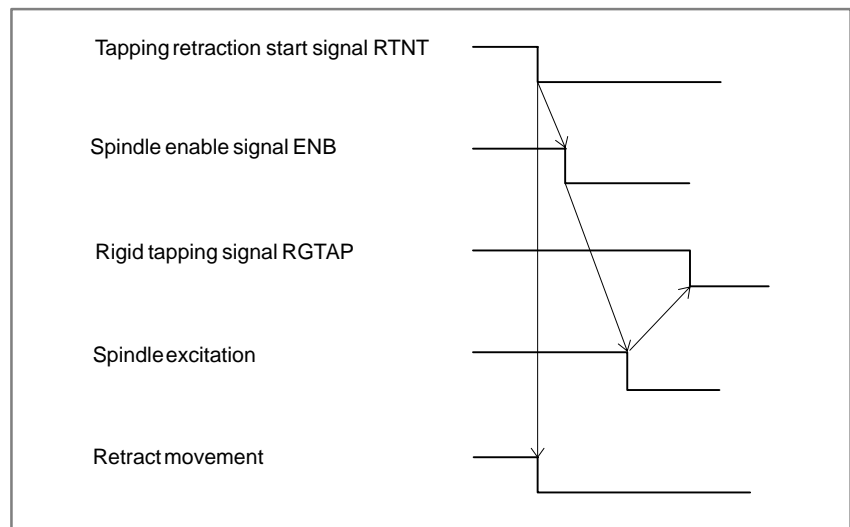

Fig. 5.13 Start and completion time chart

In the reset state, setting rigid tapping retraction start signal RTNT to “1” in MDI mode causes the rigid tapping M command to be output. For rigid tapping retraction, specify neither gear switching nor orientation. Spindle function strobe signal SF is also output if no S command has been specified after power-on.

Upon the completion of rigid tapping retraction, spindle enable signal ENB is set to “0”, in the same way as at the end of ordinary rigid tapping. Therefore, perform the sequence for canceling rigid tapping. Once rigid tapping retraction has been completed, rigid tapping retraction completion signal RTPT is set to “1” and the CNC enters the reset state.

Time chart for stopping tapping retraction



When tapping retraction is stopped, spindle enable signal is set to 0, in the same way as for ordinary rigid tapping. Therefore, perform the sequence for canceling rigid tapping. The CNC also automatically enters the reset state when tapping retraction is stopped.

Rigid tapping retraction by G30 command

- Specification method

Parameter setting allows a programmed G30 command to be used also to draw out the tool. When the power is disconnected during rigid tapping because of an accident such as a blackout, this function can draw out the tapping tool from the workpiece if an absolute position detector is provided for the servo axis.

When rigid tapping has been stopped as a result of an emergency stop or a reset, or when the power has been disconnected during rigid tapping, execute the command in the format shown below in MEM operation or MDI operation. Then, based on the rigid tapping command information in the machining program, the tool moves along the tapping axis to the initial point or R point in synchronization with the spindle. The rigid tapping retraction command is a one-shot command.

```
G30 P99 M29 S min-1 ;
```

- Time chart

The time chart for activation is the same as that of ordinary rigid tapping.

Since the G30 rigid tapping retraction command is a one-shot command, the G80 command for canceling rigid tapping is not provided. Therefore, the processing of canceling the rigid tapping signal RGTAP <G061#0> in response to the tapping retraction completion signal RTPT <F066#1> must be added to the time chart for terminating ordinary rigid tapping.

- Limitations

When the G30 command is used to perform rigid tapping (bit 1 (RG3) of parameter No. 5201 is set to 1), there are limitations as follows:

1. Rigid tapping retraction using input signal RTNT <G62#6> is not allowed.
2. Be sure to set bit 0 (G84) of parameter No. 5200 to 0.

Example:

- Machining program

```

M29 S1000 ;
G84 X20. Y20. R-10. Z-30. F500 ;
X50. Y50. ;
X100. Y100. ;
G80

```

- Retraction program

```

G30 P99 M29 S1000 ;
G00 Z-10. ;

```

(Supplementary) If a value other than 0 is set in parameter No. 5210 or 5212, the M code with the parameter-set value is specified instead of M29 in the above program.

Signal

Rigid tapping retraction start signal RTNT

<G062#6>

[Classification] Input signal

[Function] Starts rigid tapping retraction.

[Operation] When this signal is set to “1”, the control unit operates as follows:

- Starts rigid tapping retraction.

Rigid tapping retraction completion signal RTPT

<F066#1>

[Classification] Output signal

[Function] Notifies the completion of rigid tapping retraction.

[Output condition] This signal is set to “1” in the following case:

- Rigid tapping retraction has been completed.

This signal is set to “0” in the following case:

- Rigid tapping retraction start signal has been set to “0”.

Signal address

	#7	#6	#5	#4	#3	#2	#1	#0
G062		RTNT						
F066							RTPT	

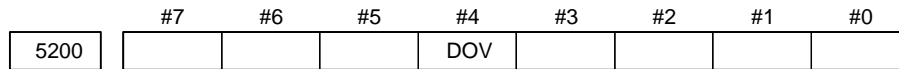
Parameter**[Data type]** Bit

DOV For tool extraction during rigid tapping, override is:
 0 : Disabled.
 1 : Enabled.

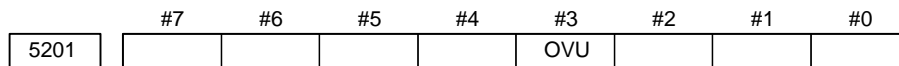
**[Data type]** Bit

OVU The increment unit of the override parameter (No.5381) for rigid tapping retraction is:
 0 : 1%
 1 : 10%

NOTE

This parameter is also used for the override value during rigid tapping extraction (No.5211).

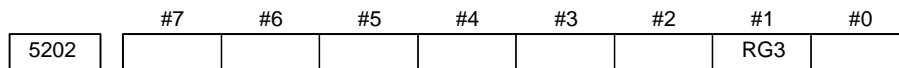
**[Data type]** Bit

RG3 Rigid tapping retraction is performed using:
 0 : Input signal RTNT <G62#6>
 1 : One-shot G code G30 command

NOTE

- 1 When this parameter has been set, the power must be turned off before operation is continued.
- 2 When this parameter is to be set to 1, be sure to set bit 0 (G84) of parameter No. 5200 to 0.

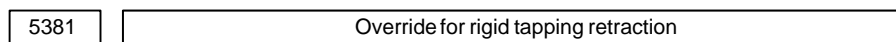
**[Data type]** Byte**[Unit of data]** %**[Valid data range]** 0 to 200

Sets an override value to be applied to rigid tapping retraction. No override is applied if 0 is set.

NOTE

- 1 This parameter is enabled only when the parameter used to enable tool extraction override (DOV:bit 4 of No.5200) is set to 1.
- 2 If bit 3(OVU) of parameter No.5201 is set to 1, 10% is set as the unit of data. Thus, an override of up to 2000% can be applied during extraction.

5382

Retract value α for rigid tapping return**[Data type]** 2-word**[Unit of data]** Input increments**[Valid data range]** 0 to 99999999

Sets an extra retract value for rigid tapping retraction. The tool will be pulled beyond the R point by α . If rigid tapping retraction has already been completed, the tool is pulled by α only.

Caution**CAUTION**

- 1 If rigid tapping is stopped as a result of an emergency stop, the position on the tapping axis (Z-axis) is maintained but the spindle position is lost. In such a case, therefore, the positional relationship between the spindle and tapping axis is not guaranteed when operation is resumed.
- 2 Rigid tapping retraction is performed based on the tapping axis (Z-axis) commands accumulated for tapping. If rigid tapping is stopped as a result of an emergency stop, therefore, rigid tapping retraction may fail to draw the tapping tool completely out of the workpiece. In such a case, set retract value α (parameter No. 5382).
- 3 During rigid tapping retraction, switching the mode to manual mode stops rigid tapping retraction.
- 4 For rigid tapping retraction, the CNC internally activates a return program. Rigid tapping retraction may, therefore, cause some G codes or M/F/S codes to be overwritten (G80/G84/G74, G94/G95, G30).

Note**NOTE**

- 1 Setting rigid tapping retraction start signal RTNT to "1" starts rigid tapping retraction only when the CNC is placed in both the reset state and MDI mode.
- 2 The machining data for rigid tapping retraction is maintained until a rigid tapping command is subsequently specified, even while the power is turned off. Rigid tapping retraction can, therefore, be specified even if the power has been turned off after rigid tapping.
- 3 Rigid tapping retraction is not performed if the input increments (inches or mm) selected when tapping return is specified differ from those selected when the machining data for tapping retraction was stored.
- 4 An override can be applied to rigid tapping retraction, if it is enabled with the corresponding parameter.

Reference item

Series 16i/18i/160i/180i/ 160is/180is	OPERATOR'S MANUAL (For Machining Center) (B-63534EN)	II.13.2	Rigid tapping
	OPERATOR'S MANUAL (For Lathe) (B-63524EN)	II.13.8	Rigid tapping
Series 21i/210i/210is	OPERATOR'S MANUAL (For Machining Center) (B-63614EN)	II.13.2	Rigid tapping
	OPERATOR'S MANUAL (For Lathe) (B-63604EN)	II.13.7	Rigid tapping
CONNECTION MANUAL (This manual)		9.11	Rigid tapping

6 INTERPOLATION FUNCTION



6.1 POSITIONING

General

The G00 command moves a tool to the position in the workpiece system specified with an absolute or an incremental command at a rapid traverse rate.

In the absolute command, coordinate value of the end point is programmed.

In the incremental command the distance the tool moves is programmed.

The tool path is determined by selecting one of the following with parameter LRP (No. 1401#1):

- Linear interpolation type positioning
The tool is positioned using a straight path and a speed that is not higher than the rapid traverse of each axis but that assures the shortest positioning time. By changing the acceleration/deceleration type from the constant acceleration/deceleration (inclination) type to the constant time (time constant) type with bit 4 (PRT) of parameter No. 1603, the tool can be moved along a specified path.
- Non-linear interpolation type positioning
Positioning is performed with each axis independently at the rapid traverse rate. Generally, the tool path is not a straight line.

The rapid traverse rate in the G00 command is set to the parameter No.1420 for each axis independently by the machine tool builder. In the positioning mode actuated by G00, the tool is accelerated to a predetermined speed at the start of a block and is decelerated at the end of a block. Execution proceeds to the next block after confirming the in-position.

Parameter

	#7	#6	#5	#4	#3	#2	#1	#0
1401							LRP	

[Data type] Bit

LRP Positioning (G00)

0 : Positioning is performed with non-linear type positioning so that the tool moves along each axis independently at rapid traverse.

1 : Positioning is performed with linear interpolation so that the tool moves in a straight line.

1420	Rapid traverse rate for each axis
------	-----------------------------------

[Data type] Two-word axis

[Unit of data]

[Valid data range]

Increment system	Unit of data	Valid data range	
		IS-A, IS-B	IS-C
Millimeter machine	1 mm/min	30 – 240000	30 – 100000
Inch machine	0.1 inch/min	30 – 96000	30 – 48000
Rotation axis	1 deg/min	30 – 240000	30 – 100000

Set the rapid traverse rate when the rapid traverse override is 100% for each axis.

	#7	#6	#5	#4	#3	#2	#1	#0
1603				PRT				

[Data type] Bit

PRT The acceleration/deceleration of interpolation-type rapid traverse is performed:

0: With a constant inclination.

1: With a constant time.

NOTE

This parameter is invalid if the function of bell-shaped acceleration/deceleration after rapid-traverse interpolation is provided. The acceleration/deceleration time constant and override for rapid traverse are used.

Note

NOTE

The rapid traverse rate cannot be specified in the address F.

Reference item

Series 16 <i>i</i> /18 <i>i</i> /160 <i>i</i> /180 <i>i</i> / 160 <i>is</i> /180 <i>is</i>	OPERATOR'S MANUAL (For Machining Center) (B-63534EN)	II.4.1	POSITIONING (G00)
	OPERATOR'S MANUAL (For Lathe) (B-63524EN)	II.4.1	POSITIONING (G00)
Series 21 <i>i</i> /210 <i>i</i> /210 <i>is</i>	OPERATOR'S MANUAL (For Machining Center) (B-63614EN)	II.4.1	POSITIONING (G00)
	OPERATOR'S MANUAL (For Lathe) (B-63604EN)	II.4.1	POSITIONING (G00)
Series 20 <i>i</i>	OPERATOR'S MANUAL (For Manual Milling Machine) (B-64204EN)	II.4.1	POSITIONING (G00)
	OPERATOR'S MANUAL (For Manual Lathes) (B-64194EN)	II.4.1	POSITIONING (G00)

6.2 LINEAR INTERPOLATION

General

Tools can move along a line

A tools move along a line to the specified position at the feedrate specified in F.

The feedrate specified in F is effective until a new value is specified. It need not be specified for each block.

The feedrate commanded by the F code is measured along the tool path. If the F code is not commanded, the feedrate is regarded as zero.

The feedrate of each axis direction is as follows.

G01 $\alpha\beta\gamma\zeta$ Ff ;

Feed rate of α axis direction : $F_{\alpha} = \frac{\alpha}{L} \times f$

Feed rate of β axis direction : $F_{\beta} = \frac{\beta}{L} \times f$

Feed rate of γ axis direction : $F_{\gamma} = \frac{\gamma}{L} \times f$

Feed rate of ζ axis direction : $F_{\zeta} = \frac{\zeta}{L} \times f$

$$L = \sqrt{\alpha^2 + \beta^2 + \gamma^2 + \zeta^2}$$

The feedrate of the rotary axis is commanded in the unit of deg/min (if the feedrate is 12 deg/min, F12.0 is commanded).

When the straight line axis α (such as X, Y, or Z) and the rotating axis β (such as A, B, or C) are linearly interpolated, the feed rate is that in which the tangential feed rate in the α and β cartesian coordinate system is commanded by F(mm/min).

β -axis feedrate is obtained ; at first, the time required for distribution is calculated by using the above formula, then the β -axis feedrate unit is changed to deg/min.

A calculation example is as follows.

(Example)

G91 G01 X20.0C40.0 F300.0 ;

This changes the unit of the C axis from 40.0 deg to 40mm with metric input. The time required for distribution is calculated as follows:

$$\frac{\sqrt{20^2 + 40^2}}{300} \doteq 0.14907 \text{ (min)}$$

The feed rate for the C axis is

$$\frac{40 \text{ deg}}{0.14907 \text{ min}} \doteq 268.3 \text{ deg/min}$$

In simultaneous 3 axes control, the feed rate is calculated the same way as in 2 axes control.

Parameter

1411	
	Cutting feedrate when the power is turned on

This parameter can be set in “Setting screen”.

[Data type] Word

[Unit of data]

[Valid data range]

Increment system	Unit of data	Valid data range	
		IS-A, IS-B	IS-C
Millimeter machine	1 mm/min	6 – 32767	6 – 32767
Inch machine	0.01 inch/min	6 – 32767	6 – 32767

When the machine requires little change in cutting feedrate during cutting, a cutting feedrate can be specified in the parameter. This eliminates the need to specify a cutting feedrate in the NC command data.

The feedrate set in this parameter is effective between the CNC being cleared, upon a power-on or a reset, and a feedrate being specified with a program command (F command). Once a feedrate has been specified with an F command, that feedrate becomes effective.

1422	
	Maximum cutting feedrate for all axes

[Data type] Two-word axis

[Unit of data]

[Valid data range]

Increment system	Unit of data	Valid data range	
		IS-A, IS-B	IS-C
Millimeter machine	1 mm/min	6 – 240000	6 – 100000
Inch machine	0.1 inch/min	6 – 96000	6 – 48000

Specify the maximum cutting feedrate.

A feedrate in the tangential direction is clamped in cutting feed so that it does not exceed the feedrate specified in this parameter.

NOTE

To specify the maximum cutting feedrate for each axis, use parameter No. 1430 instead. (M series)

1430	
	Maximum cutting feedrate for each axis

[Data type] Two-word axis

[Unit of data]

[Valid data range]

Increment system	Unit of data	Valid data range	
		IS-A, IS-B	IS-C
Millimeter machine	1 mm/min	6 – 240000	6 – 100000
Inch machine	0.1 inch/min	6 – 96000	6 – 48000
Rotation axis	1 deg/min	6 – 240000	6 – 100000

Specify the maximum cutting feedrate for each axis.

A feedrate for each axis is clamped in cutting feed so that it does not exceed the maximum feedrate specified for each axis.

NOTE

- 1 This parameter is effective only in linear and circular interpolation. In polar coordinate, cylindrical, and involute interpolation, the maximum feedrate for all axes specified in parameter No. 1422 is effective.
- 2 If the setting for each axis is 0, the maximum feedrate specified in parameter No. 1422 is applied to all axes and the feedrate is clamped at the maximum feedrate.

	#7	#6	#5	#4	#3	#2	#1	#0
3402								G01

[Data type] Bit

G01 Mode entered when the power is turned on or when the control is cleared

0: G00 mode (positioning)

1: G01 mode (linear interpolation)

Alarm and message

No.	Message	Description
011	NO FEEDRATE COMMANDED	Cutting feedrate was not commanded or the feedrate was inadequate. Modify the program.

Reference item

Series 16i/18i/160i/180i/ 160is/180is	OPERATOR'S MANUAL (For Machining Center) (B-63534EN)	II.4.3	LINEAR INTERPOLATION (G01)
	OPERATOR'S MANUAL (For Lathe) (B-63524EN)	II.4.3	LINEAR INTERPOLATION (G01)
Series 21i/210i/210is	OPERATOR'S MANUAL (For Machining Center) (B-63614EN)	II.4.3	LINEAR INTERPOLATION (G01)
	OPERATOR'S MANUAL (For Lathe) (B-63604EN)	II.4.2	LINEAR INTERPOLATION (G01)
Series 20i	OPERATOR'S MANUAL (For Manual Milling Machine) (B-64204EN)	II.4.3	LINEAR INTERPOLATION (G01)
	OPERATOR'S MANUAL (For Manual Lathes) (B-64194EN)	II.4.2	LINEAR INTERPOLATION (G01)

6.3 CIRCULAR INTERPOLATION

General

The command below can move a tool along a circular arc in the defined plane.

“Clockwise”(G02) and “counterclockwise”(G03) on the X_pY_p plane (Z_pX_p plane or Y_pZ_p plane) are defined when the X_pY_p plane is viewed in the positive-to-negative direction of the Z_p axis (Y_p axis or X_p axis, respectively) in the Cartesian coordinate system. See the figure below.

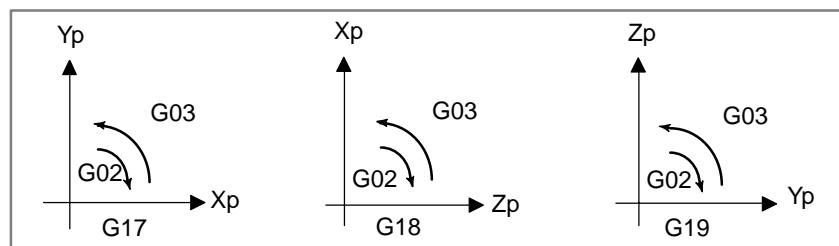

The end point of an arc is specified by address X_p , Y_p or Z_p , and is expressed as an absolute or incremental value according to G90 or G91. For the incremental value, the distance of the end point which is viewed from the start point of the arc is specified with a sign.

The arc center is specified by addresses I, J, and K for the X_p , Y_p , and Z_p axes, respectively. The numerical value following I, J, or K, however, is a vector component in which the arc center is seen from the start point, and is always specified as an incremental value, as shown below.

I, J, and K must be signed according to the direction.

G02; Command for a circle

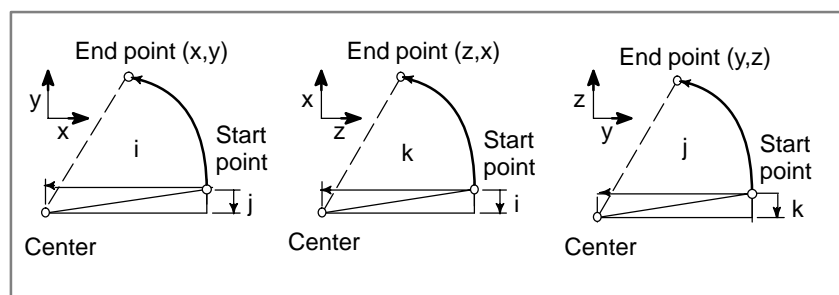

I0, J0, and K0 can be omitted. When X_p , Y_p , and Z_p are omitted (the end point is the same as the start point) and the center is specified with I, J, and K, a 360° arc (circle) is specified.

G02 Ii; Command for a circle

If the difference between the radius at the start point and that at the end point exceeds the value in a parameter (No.3410), an alarm (No.020) occurs.

The distance between an arc and the center of a circle that contains the arc can be specified using the radius, R , of the circle instead of I , J , and K . In this case, one arc is less than 180° , and the other is more than 180° are considered.

For T series, an arc with a sector angle of 180° or wider cannot be specified (P/S alarm No. 023).

For M series, specify an arc more than 180° with a negative radius value commanded.

If X_p , Y_p , and Z_p are all omitted, if the end point is located at the same position as the start point and when R is used, an arc of 0° is programmed. $G02Rr$; (The tool does not move.)

(Example) (T series)

For arc (1) (less than 180°)

$G02 W60.0 U10.0 R50.0 F300.0$;

For arc (2) (greater than 180°)

An arc with a sector angle of 180° or wider cannot be specified within a single block.

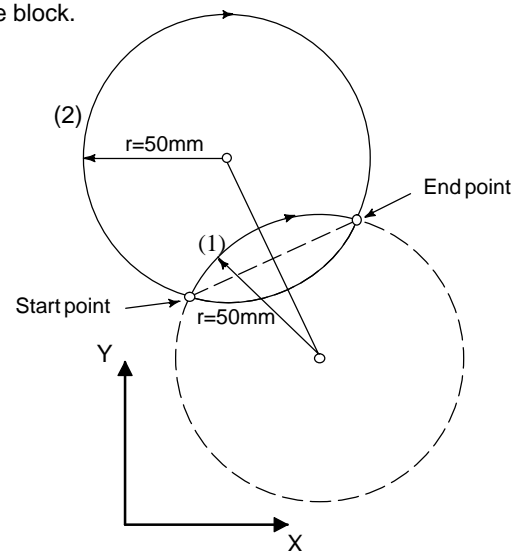

(Example) (M series)

For arc (1) (less than 180°)

G91 G02 X60.0 Y20.0 R50.0 F300.0 ;

For arc (2) (greater than 180°)

G91 G02 X60.0 Y20.0 R-50.0 F300.0 ;

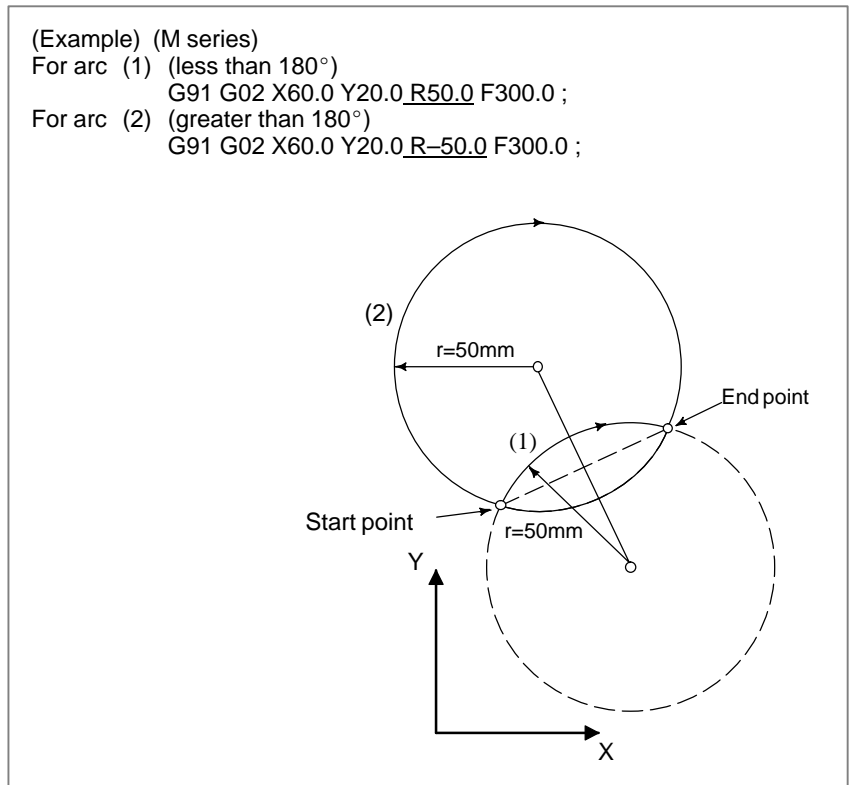

When the option for specifying arc radius R with nine digits is selected for the T series, the valid radius range for circular interpolation is expanded as follows:

		Input increments	
		Metric input	Inch input
Increment system	IS-B	0.001 to 999999.999 mm	0.0001 to 99999.9999 inch
	IS-C	0.0001 to 99999.9999 mm	0.00001 to 9999.99999 inch

NOTE

- 1 Specifying an arc center with addresses I, K, and J
When the distance from the arc start point to the arc center is specified with addresses I, K, and J, a P/S alarm (No. 5059) is issued if:

$$\text{Maximum value which can be specified} < \sqrt{I^2 + K^2}$$

Example:

When IS-B and metric input are selected, issuing the following command (radius specification) will result in the issue of a P/S alarm (No. 5059):

G50 X0 Z0;

G18 G02 X11.250 Z10. I-800000.000 K900000.000 F5.0;

$$\begin{aligned} \because \sqrt{I^2 + K^2} &= \sqrt{(-800000.000)^2 + 900000.000^2} \\ &= 1204159.458 \\ &> 999999.999 \end{aligned}$$

- 2 Tool nose radius compensation

In tool nose radius compensation mode, a P/S alarm (No. 5059) is issued if the distance from the tool nose radius center to the arc center exceeds the maximum value which can be specified.

The feedrate in circular interpolation is equal to the feedrate specified by the F code, and the feedrate along the arc (the tangential feedrate of the arc) is controlled to be the specified feedrate.

The error between the specified feedrate and the actual tool feedrate is $\pm 2\%$ or less. However, this feedrate is measured along the arc after the cutter compensation (M series) or tool nose radius compensation (T series) is applied.

Parameter

1022	Setting of each axis in the basic coordinate system
------	---

NOTE
When this parameter is set, power must be turned off before operation is continued.

[Data type] Byte axis

To determine the following planes used for circular interpolation, cutter compensation C (for the M series), tool nose radius compensation (for the T series), etc., each control axis is set to one of the basic three axes X, Y, and Z, or an axis parallel to the X, Y, or Z axis.

G17: Plane Xp–Yp

G18: Plane Zp–Xp

G19: Plane Yp–Zp

Only one axis can be set for each of the three basic axes X, Y, and Z, but two or more parallel axes can be set.

Set value	Meaning
0	Neither the basic three axes nor a parallel axis
1	X axis of the basic three axes
2	Y axis of the basic three axes
3	Z axis of the basic three axes
5	Axis parallel to the X axis
6	Axis parallel to the Y axis
7	Axis parallel to the Z axis

3402	#7	#6	#5	#4	#3	#2	#1	#0
						G19	G18	

[Data type] Bit

G18 and G19 Plane selected when power is turned on or when the control is cleared

G19	G18	G17, G18 or G19 mode
0	0	G17 mode (plane XY)
0	1	G18 mode (plane ZX)
1	0	G19 mode (plane YZ)

3410	Tolerance of arc radius
------	-------------------------

[Data type] Two-word

[Unit of data]	Increment system	IS-A	IS-B	IS-C	Unit
	Metric input	0.01	0.001	0.0001	mm
	Inch input	0.001	0.0001	0.00001	inch

[Valid data range] 1 to 99999999

When a circular interpolation command (G02, G03) is executed, the tolerance for the radius between the start point and the end point is set. If the difference of radii between the start point and the end point exceeds the tolerance set here, a P/S alarm No. 20 is informed.

NOTE

When the set value is 0, the difference of radii is not checked.

Alarm and message

Number	Message	Description
011	NO FEEDRATE COMMANDED	Cutting feedrate was not commanded or the feedrate was inadequate. Modify the program.
020	OVER TOLERANCE OF RADIUS	In circular interpolation (G02 or G03), difference of the distance between the start point and the center of an arc and that between the end point and the center of the arc exceeded the value specified in parameter No. 3410.
021	ILLEGAL PLANE AXIS COMMANDED	An axis not included in the selected plane (by using G17, G18, G19) was commanded in circular interpolation. Modify the program.
023	ILLEGAL RADIUS COMMAND (T series)	In circular interpolation by radius designation, negative value was commanded for address R. Modify the program.
025	CANNOT COMMAND F0 IN G02/G03 (M series)	F0 (rapid traverse) was instructed by F1 -digit command in circular interpolation. Modify the program.
028	ILLEGAL PLANE SELECT	In the plane selection command, two or more axes in the same direction are commanded. Modify the program.
5059	RADIUS IS OUT OF RANGE	For circular interpolation, the radius specified with addresses I and K exceeds the allowable range.

Note**NOTE**

- 1 For T series, the U, V and W axes (parallel with the basic axis) can be used with G-code system B and C.
- 2 If I, J, K, and R addresses are specified simultaneously, the arc specified by address R takes precedence and the other are ignored.
- 3 If an axis not comprising the specified plane is commanded, an alarm is displayed.

For example, when G code system B or C is used, if U axis with X axis is specified as a parallel axis to X axis when plane XY is specified, an P/S alarm (No.028) is displayed.

Reference item

Series 16i/18i/160i/180i/ 160is/180is	OPERATOR'S MANUAL (For Machining Center) (B-63534EN)	II.4.4	CIRCULAR INTERPOLATION (G02,G03)
	OPERATOR'S MANUAL (For Lathe) (B-63524EN)	II.4.4	CIRCULAR INTERPOLATION (G02,G03)
Series 21i/210i/210is	OPERATOR'S MANUAL (For Machining Center) (B-63614EN)	II.4.4	CIRCULAR INTERPOLATION (G02,G03)
	OPERATOR'S MANUAL (For Lathe) (B-63604EN)	II.4.3	CIRCULAR INTERPOLATION (G02,G03)
Series 20i	OPERATOR'S MANUAL (For Manual Milling Machine) (B-64204EN)	II.4.4	CIRCULAR INTERPOLATION (G02,G03)
	OPERATOR'S MANUAL (For Manual Lathes) (B-64194EN)	II.4.3	CIRCULAR INTERPOLATION (G02,G03)

6.4 THREAD CUTTING

6.4.1 Thread Cutting

General

Tool movement can be synchronized with spindle rotation when cutting threads.

The spindle speed is continuously read through the position coder attached to the spindle. Then, it is converted to a cutting feedrate (feed per minute) to feed the tool.

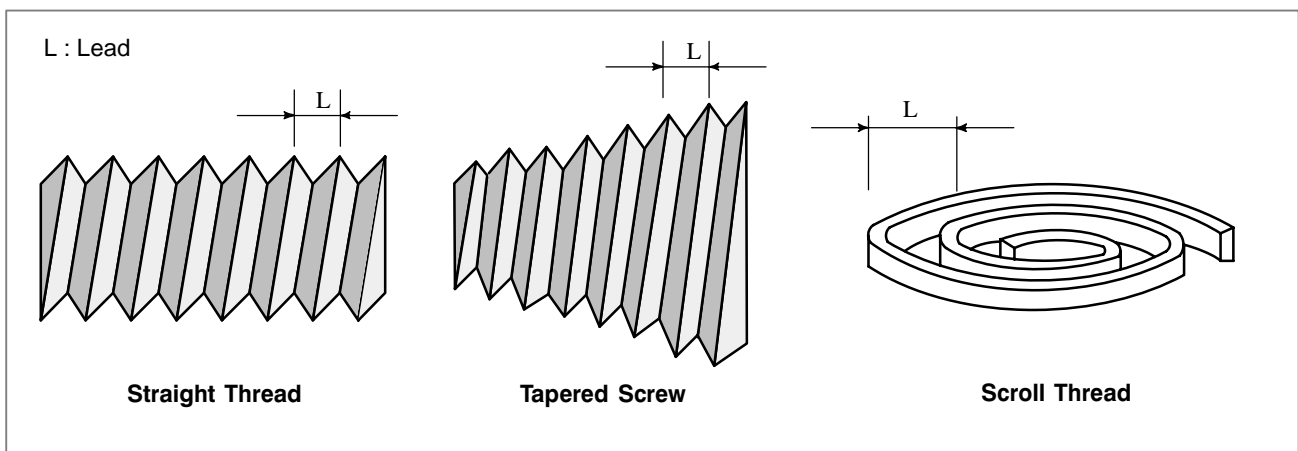

In general, thread cutting is repeated along the same tool path in rough cutting through finish cutting for a screw. Since thread cutting starts when the position coder mounted on the spindle outputs a 1-turn signal, threading is started at a fixed point and the tool path on the workpiece is unchanged for repeated thread cutting. Note that the spindle speed must remain constant from rough cutting through finish cutting. If not, incorrect thread lead will occur.

Signal

Thread cutting signal THRD<F002#3>

[Function] This signal indicates that thread cutting is in progress.

[Output condition] This signal turns to “1” in the following cases:

- Thread cutting mode in progress
- Thread cutting cycle for turning

This signal turns to “0” in the following case.

- Neither thread cutting mode nor thread cutting cycle are in progress.
-

Signal address

	#7	#6	#5	#4	#3	#2	#1	#0
F002					THRD			

Parameter

Enabling/disabling dry run operation during threading

	#7	#6	#5	#4	#3	#2	#1	#0
1401			TDR					

[Data type] Bit

TDR Dry run during threading or tapping (tapping cycle G74 or G84, rigid tapping)

- 0 : Enabled
- 1 : Disabled

Setting the thread cutting

	#7	#6	#5	#4	#3	#2	#1	#0
3405					G36			

[Data type] Bit

G36 For a G code used with the automatic tool compensation function:

- 0 : G36/G37 is used
- 1 : G37.1/G37.2 is used

If it is necessary to perform circular threading (counterclockwise), set this parameter to 1.

Checking the spindle speed arrival signal before starting threading

	#7	#6	#5	#4	#3	#2	#1	#0
3708							SAT	SAR
								SAR

[Data type] Bit

SAR: The spindle speed arrival signal is:

- 0 : Not checked
- 1 : Checked

SAT: Check of the spindle speed arrival signal at the start of executing the thread cutting block

- 0 : The signal is checked only when SAR, #0 of parameter 3708, is set.
- 1 : The signal is always checked irrespective of whether SAR is set.

CAUTION

When thread cutting blocks are consecutive, the spindle speed arrival signal is not checked for the second and subsequent thread cutting blocks.

Setting the start type for threading

	#7	#6	#5	#4	#3	#2	#1	#0
3708	THB							

[Data type] Bit

THB: The start type for threading is:

- 0 : A type
- 1 : B type

CAUTION

When PMC axis control is used, set this parameter to 1.

Setting the time constant for the threading cycle

1626	Time constant of exponential acceleration/deceleration in the thread cutting cycle for each axis

[Data type] Word axis

[Unit of data] ms

[Valid data range] 0 to 4000

Set the time constant used for exponential acceleration/deceleration in the thread cutting cycle (G76, G78 (G92 in G code system A)) for each axis.

Setting the FL feedrate for the thread cutting cycle

1627	FL rate of exponential acceleration /deceleration in the thread cutting cycle for each axis

[Data type] Word axis

[Unit of data]	Increment system	Unit of data	Valid data range	
[Valid data range]			IS-A, IS-B	IS-C
	Millimeter machine	1 mm/min	6 – 15000	6 – 12000
	Inch machine	0.1 inch/min	6 – 6000	6 – 4800
	Rotation axis	1 deg/min	6 – 15000	6 – 12000

Set the lower limit (FL rate) of exponential acceleration/deceleration in the thread cutting cycle (G76, G78 (G92 in G code system A)) for each axis.

Setting the chamfering distance for the thread cutting cycle

5130	Chamfering distance in the thread cutting cycles G76 and G92

[Data type] Byte

[Unit of data] 0.1 pitch

[Valid data range] 0 to 127

This parameter sets the chamfering in the thread cutting cycles G76 and G92.

Setting the minimum depth of cut for the multiple repetitive canned cycle G76

5140	Minimum depth of cut in the multiple repetitive canned cycle G76

[Data type] Two-word

[Unit of data]	Increment system	IS-A	IS-B	IS-C	Unit
	Metric input	0.01	0.001	0.0001	mm
	Inch input	0.001	0.0001	0.00001	inch

[Valid data range] 0 to 99999999

This parameter sets the minimum depth of cut in the multiple repetitive canned cycle G76.

Setting the finishing allowance for the multiple repetitive canned cycle G76

5141	Finishing allowance in the multiple repetitive canned cycle G76

[Data type] Two-word

[Unit of data]	Increment system	IS-A	IS-B	IS-C	Unit
	Metric input	0.01	0.001	0.0001	mm
	Inch input	0.001	0.0001	0.00001	inch

[Valid data range] 1 to 99999999

This parameter sets the finishing allowance in the multiple repetitive canned cycle G76.

Setting the repetition count of finishing for the multiple repetitive canned cycle G76

5142	Repetition count of final finishing in the multiple repetitive canned cycle G76

[Data type] Two-word

[Unit of data] Cycle

[Valid data range] 1 to 99999999

This parameter sets the repetition count in the multiple repetitive canned cycle G76.

Setting the tool angle for the multiple repetitive canned cycle G76

5143	Tool nose angle in the multiple repetitive canned cycle G76

[Data type] Two-word

[Unit of data] Degree

[Valid data range] 0 to 120 (When FS15 TAPE FORMAT is used)
0, 29, 30, 55, 60, 80 (When FS15 TAPE FORMAT is not used)

This parameter sets the tool nose angle in the multiple repetitive canned cycle G76.

Warning**WARNING**

During threading, stopping feed without stopping the spindle is dangerous because the cutting depth will abruptly increase. Feed hold is, therefore, disabled during threading. If attempted during threading, feed stops in the same way as single block stop upon the completion of the first non-threading block after the termination of threading mode. The feed hold lamp (SPL lamp), however, lights immediately after the feed hold button (on the machine operator's panel) is pressed. The lamp goes off when feed stops (the CNC enters the single block stop state).

Caution**CAUTION**

- 1 Feedrate override is ignored during thread cutting, 100% being assumed.
- 2 During threading, spindle override is ignored, 100% being assumed.
- 3 When the first non-threading block is executed after threading mode has been finished, and the feed hold button is pressed again (or the feed hold button has been held down), the execution of the non-threading block is stopped immediately.
- 4 When thread cutting is executed in the single block status, the tool stops after execution of the first block not specifying thread cutting.
- 5 When the previous block was a thread cutting block, cutting will start immediately without waiting for detection of the 1-turn signal even if the present block is a thread cutting block.
- 6 When a dry run operation is performed the dry run rate becomes the longitudinal axis feedrate.
- 7 For T series, the thread cutting retract function is supported only for the threading cycle.
- 8 When PMC axis control is used, set bit 7 (THB) of parameter No. 3709 to 1.

Reference item

Series 16 <i>i</i> /18 <i>i</i> /160 <i>i</i> /180 <i>i</i> / 160 <i>s</i> /180 <i>s</i>	OPERATOR'S MANUAL (For Machining Center) (B-63534EN)	II.4.15	THREAD CUTTING
	OPERATOR'S MANUAL (For Lathe) (B-63524EN)	II.4.9	CONSTANT LEAD THREAD CUTTING
		II.4.10	VARIABLE LEAD THREAD CUTTING
		II.4.11	CONTINUOUS THREAD CUTTING
		II.4.12	MULTIPLE THREAD CUTTING
		II.4.13	CIRCULAR THREAD CUTTING
Series 21 <i>i</i> /210 <i>i</i> /210 <i>s</i>	OPERATOR'S MANUAL (For Machining Center) (B-63614EN)	II.4.7	THREAD CUTTING
	OPERATOR'S MANUAL (For Lathe) (B-63604EN)	II.4.6	CONSTANT LEAD THREAD CUTTING
		II.4.7	VARIABLE LEAD THREAD CUTTING
		II.4.8	CONTINUOUS THREAD CUTTING
		II.4.9	MULTIPLE THREAD CUTTING
Series 20 <i>i</i>	OPERATOR'S MANUAL (For Manual Lathes) (B-64194EN)	II.4.4	CONSTANT LEAD THREAD CUTTING
		II.4.5	VARIABLE LEAD THREAD CUTTING
		II.4.6	CONTINUOUS THREAD CUTTING
		II.4.7	MULTIPLE THREAD CUTTING

6.4.2 Thread Cutting Cycle Retract (T series)

General

When the automatic operation stop signal *SP <G008#5> is set to 0 during threading in a threading cycle, the tool immediately retracts while performing chamfering, then returns to the start point of the current cycle, first along the X-axis, then along the Z-axis.

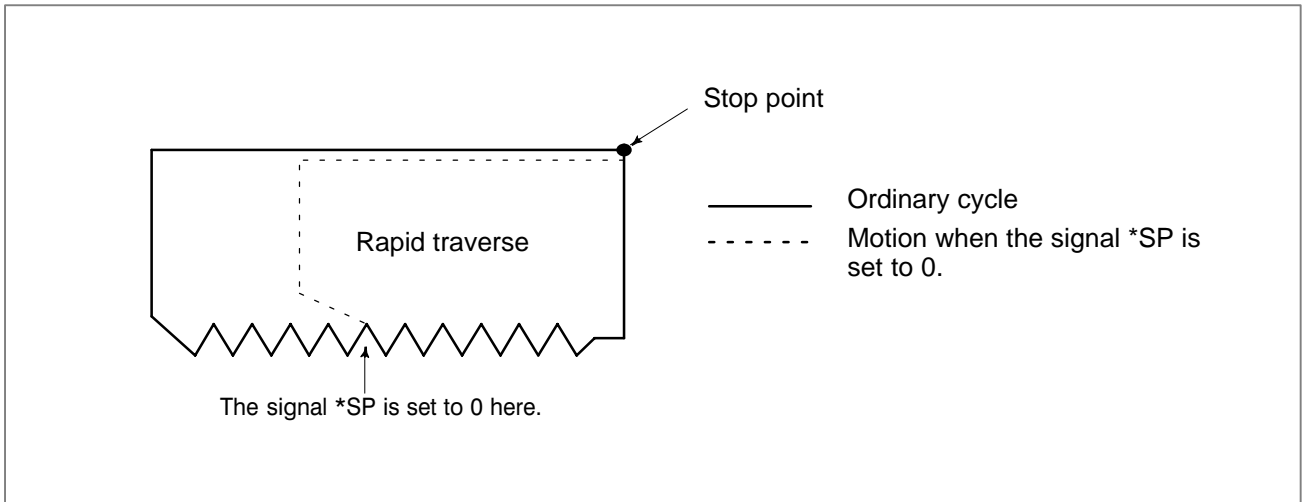

Parameter

- **Setting to enable the override function during thread cutting cycle retraction**

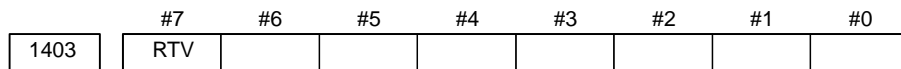

[Data type] Bit

RTV Override while the tool is retracting in threading
 0 : Override is effective.
 1 : Override is not effective.

- **Setting a chamfering distance in thread cutting cycle retraction**

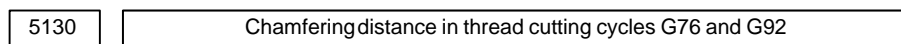

[Data type] Byte

[Unit of data] 0.1 pitch

[Valid data range] 0 to 127

This parameter sets the chamfering in thread cutting cycles G76 and G92.

Caution**CAUTION**

While the tool is retracting, automatic operation stop signal *SP <G008#5> is ignored.

Note**NOTE**

The chamfering distance for retraction is determined by the setting of parameter No. 5130.

Reference item

Series 16i/18i/160i/180i/ 160is/180is	OPERATOR'S MANUAL (For Lathe) (B-63524EN)	II.13.1.2	Thread Cutting Cycle
		II.13.2.7	Multiple Thread Cutting Cycle
Series 21i/210i/210is	OPERATOR'S MANUAL (For Lathe) (B-63604EN)	II.13.1.2	Thread Cutting Cycle
		II.13.2.7	Multiple Thread Cutting Cycle
Series 20i	OPERATOR'S MANUAL (For Manual Lathes) (B-64194EN)	II.13.1.2	Thread Cutting Cycle
		II.13.2.7	Multiple Thread Cutting Cycle

6.5 SINGLE DIRECTION POSITIONING

General

For accurate positioning without play of the machine (lost motion), positioning is performed in one direction finally.

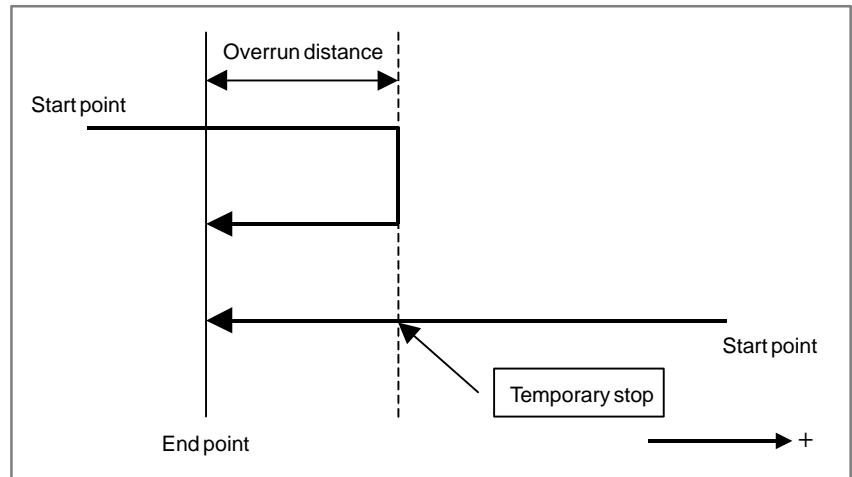

Example where positioning is performed in the minus direction

Format

```
G60 IP_;
  IP_ : Coordinates of an end point for tool movement when an
        absolute command is specified
```

Explanation

Parameter No. 5440 is used to set an overrun distance and positioning direction. The tool stops once before a specified end point also when a specified positioning direction matches the positioning direction set in the parameter.

By setting bit 0 (MDL) of parameter No. 5431 to 1, the one-shot G code G60 can be used as a modal G code of group 01. This eliminates the need to specify G60 for each block, and enables one-shot G code to be specified in the single direction positioning mode. The other specifications are the same as for the one-shot G code G60.

(Example)	
When the one-shot G code G60 is used	When the modal G code G60 is used
<pre>G90 ; G60 X0 Y0 ; G60 X100 ; G60 Y100 ; G04 X10 ; G00 X0 Y0 ;</pre>	<pre>G90 G60 ; X0 Y0 ; X100 ; Y100 ; G04 X10 ; G00 X0 Y0 ;</pre>
<pre> } Single direction positioning </pre>	<pre> } Single direction positioning } Closes the single direction positioning mode. </pre>

● Overview of operation

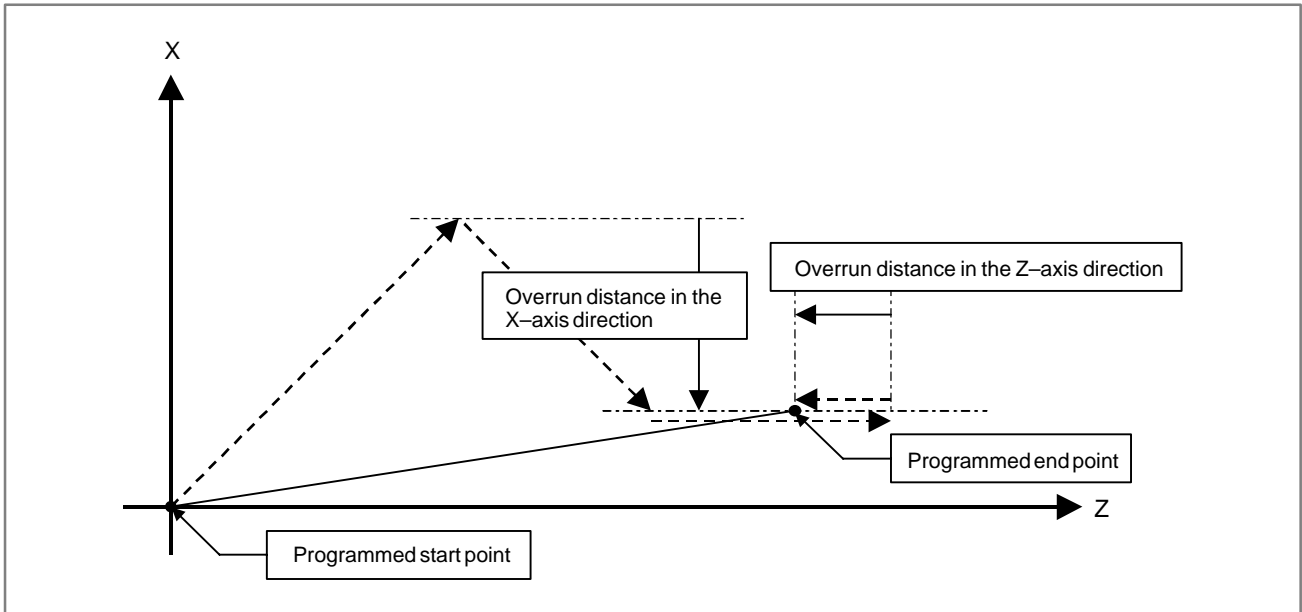

In the case of positioning of non-linear interpolation type (bit 1 (LRP) of parameter No. 1401 = 0)

As shown above, single direction positioning is performed independently along each axis.

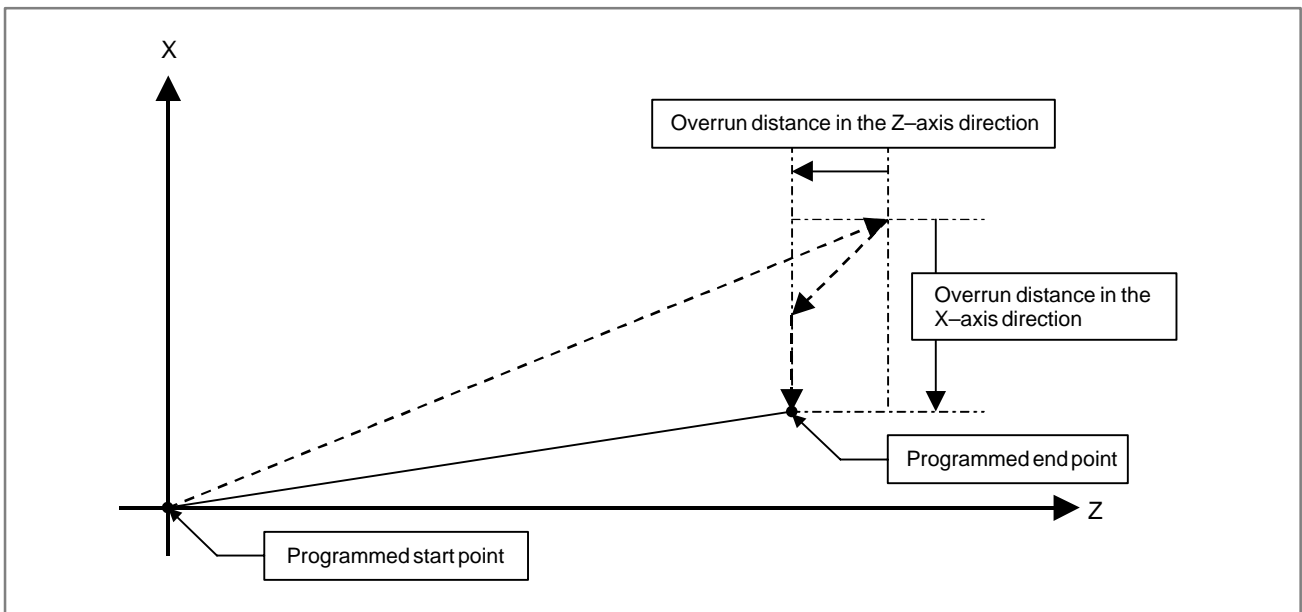

In the case of positioning of linear interpolation type (bit 1 (LRP) of parameter No. 1401 = 1)

Positioning of interpolation type is performed until the tool once stops before or after a specified end point. Then, the tool is positioned independently along each axis until the end point is reached.

Parameter

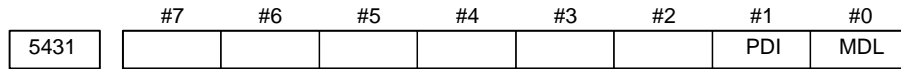

[Data type] Bit

MDL Specifies whether the G code for single direction positioning (G60) is included in one-shot G codes (00 group) or modal G codes (01 group)

0: One-shot G codes (00 group)

1: Modal G codes (01 group)

PDI When the tool is stopped before or after a specified end point with the single direction positioning function:

0 : No in-position check is performed.

1 : An in-position check is performed.

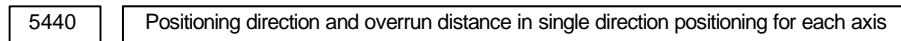

[Data type] Word axis

[Unit of data]

Increment system	IS-A	IS-B	IS-C	Unit
Metric input	0.01	0.001	0.0001	mm
Inch input	0.001	0.0001	0.00001	inch
Rotation axis	0.01	0.001	0.0001	deg

[Valid data range] -16383 to +16383

This parameter sets the positioning direction and overrun distance in single directional positioning (G60) for each axis. The positioning direction is specified using a setting data sign, and the overrun distance using a value set here.

Approach > 0: The positioning direction is positive (+).

Approach < 0: The positioning direction is negative (-).

Approach = 0: Uni-directional positioning is not performed.

P/S alarm

Number	Message	Description
0146	IMPROPER G CODE	In the polar coordinate interpolation mode, a G code that must not be specified was specified. Correct the program.
0176	IMPROPER G CODE IN G107	In the cylindrical interpolation mode, a G code that must not be specified was specified. Correct the program.

Notes

1. Single direction positioning is not performed along an axis for which no overrun distance is set in parameter No. 5440.
2. Single direction positioning is not performed along an axis for which travel distance 0 is specified.
3. The mirror image function is not applied in a parameter-set direction. Even in the mirror image mode, the direction of single direction positioning remains unchanged.
4. Single direction positioning cannot be used for a hole machining axis in a hole machining canned cycle. However, single direction positioning can be used for positioning operation.
5. In the cylindrical interpolation mode (G07.1), single direction positioning cannot be used.
6. In the polar coordinate interpolation mode (G12.1), single direction positioning cannot be used.
7. Single direction positioning is not performed for an axis along which a movement is made by a shift amount in a G76 or G87 canned cycle. (M series)
8. The G code for single direction positioning is G60, regardless of whether the G code system is A, B, or C. (T series)
9. In a multiple repetitive turning canned cycle (G70 to G76), single direction positioning cannot be used. (T series)
10. In a grind canned cycle (G71 to G74), single direction positioning cannot be used. (T series)
11. In a canned cycle (G90, G92, G94), single direction positioning cannot be used. (T series)

● **Notes on using single direction positioning and angular axis control simultaneously**

If a move command is specified on an angular axis in angular axis control, a compensation command is output for the orthogonal axis. Let Y_p be a move command for an angular axis, and let θ be the inclination angle of the angular axis. Then, the compensation command X_a for the orthogonal axis is:

$$X_a = -Y_p \cdot \tan \theta$$

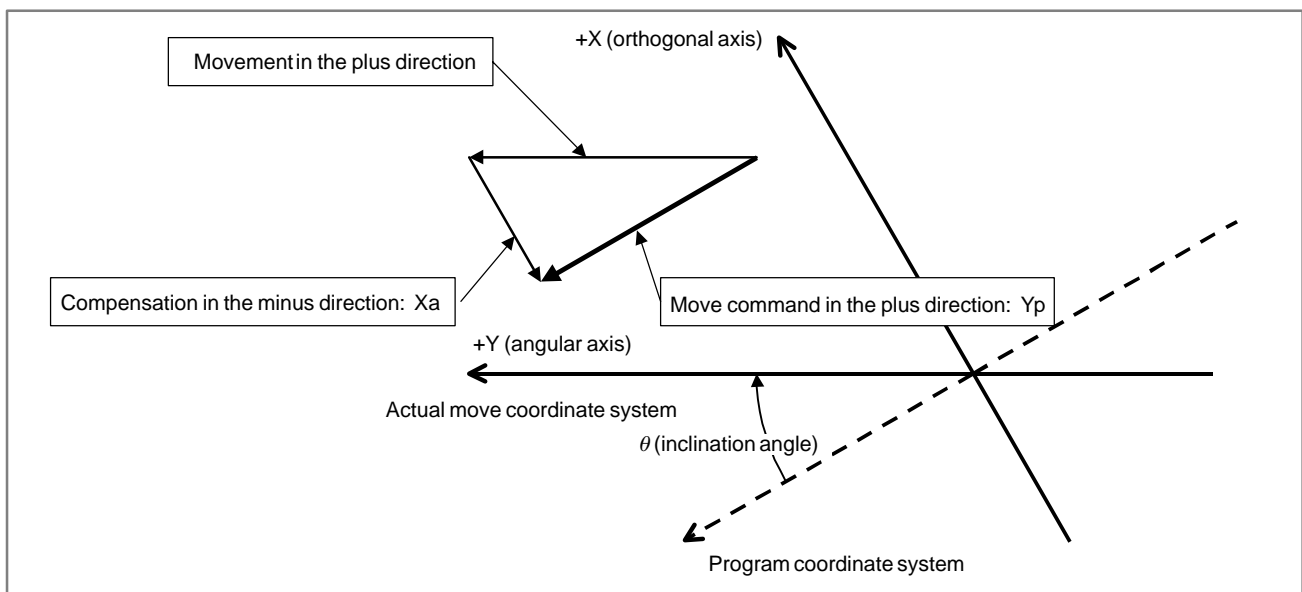

The direction of the compensation command X_a is determined by the inclination angle θ of the angular axis and the direction of the move command Y_p for the orthogonal axis. When $\tan \theta$ is plus, the direction of the move command for the angular axis is opposite to that of the compensation command for the orthogonal axis. (For example, if a move command in the plus direction is specified for an angular axis when the inclination angle is $+30^\circ$, a compensation command in the minus direction is output for the orthogonal axis.)

So, when single direction positioning is performed during angular axis control, positioning may be performed by a compensation command along the orthogonal axis in the direction opposite to the direction set in parameter No. 5440. To prevent this situation from occurring, set the parameter as described below so that the direction of the compensation command matches the positioning direction for the orthogonal axis.

- **When the inclination angle of an angular axis (parameter No. 8210) is 1° to 89° or 181° to 269°**

Set the directions of single direction positioning (parameter No. 5440) for the angular axis and orthogonal axis so that the directions for the angular axis and for the orthogonal axis are opposite (plus/minus) to each other. When the positioning direction for the X-axis (orthogonal axis) is minus, and the positioning direction for the Y-axis (angular axis) is plus, the operation shown below is performed.

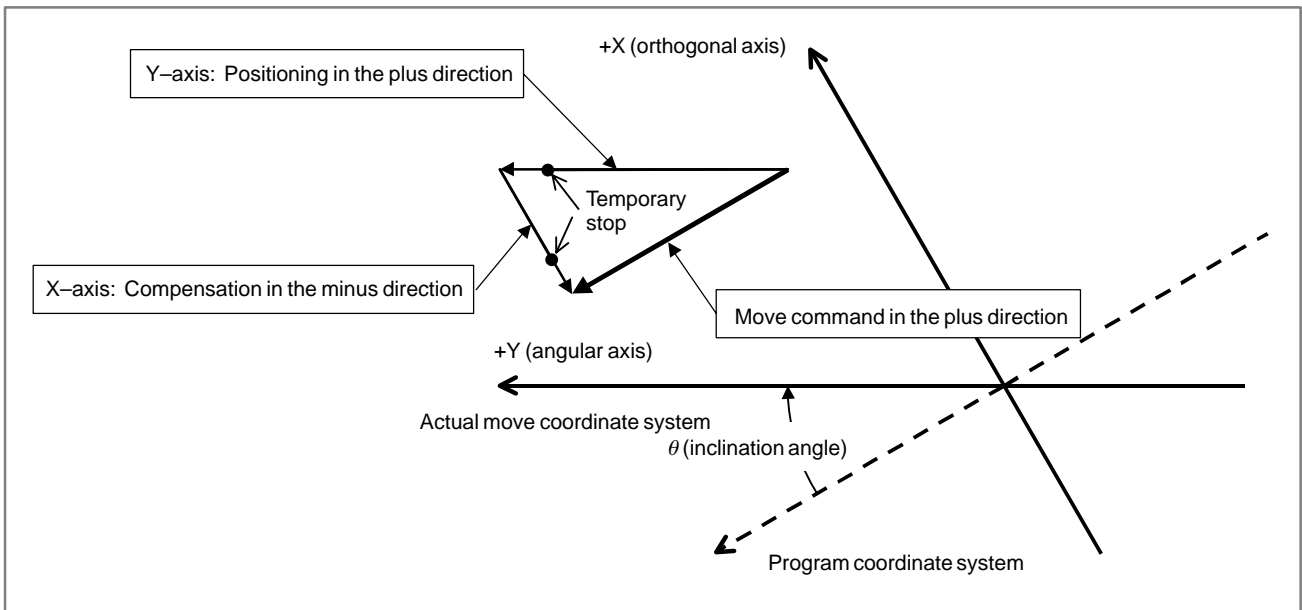

Move command in the plus direction

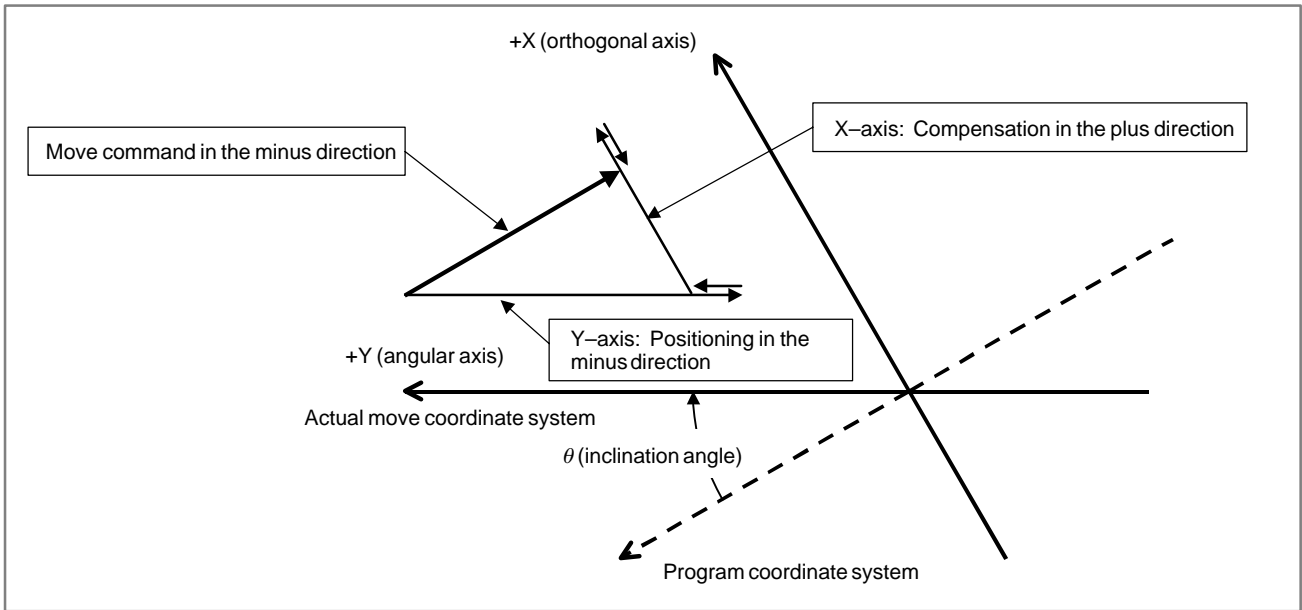

Move command in the minus direction

- **When the inclination angle of an angular axis (parameter No. 8210) is 91° to 179° or 271° to 359°**

Set the directions of single direction positioning (parameter No. 5440) for the angular axis and orthogonal axis so that the directions for the angular axis and for the orthogonal axis are the same (plus and plus, or minus and minus).

When both of the positioning directions for the X-axis (orthogonal axis) and for the Y-axis (angular axis) are plus, the operation shown below is performed.

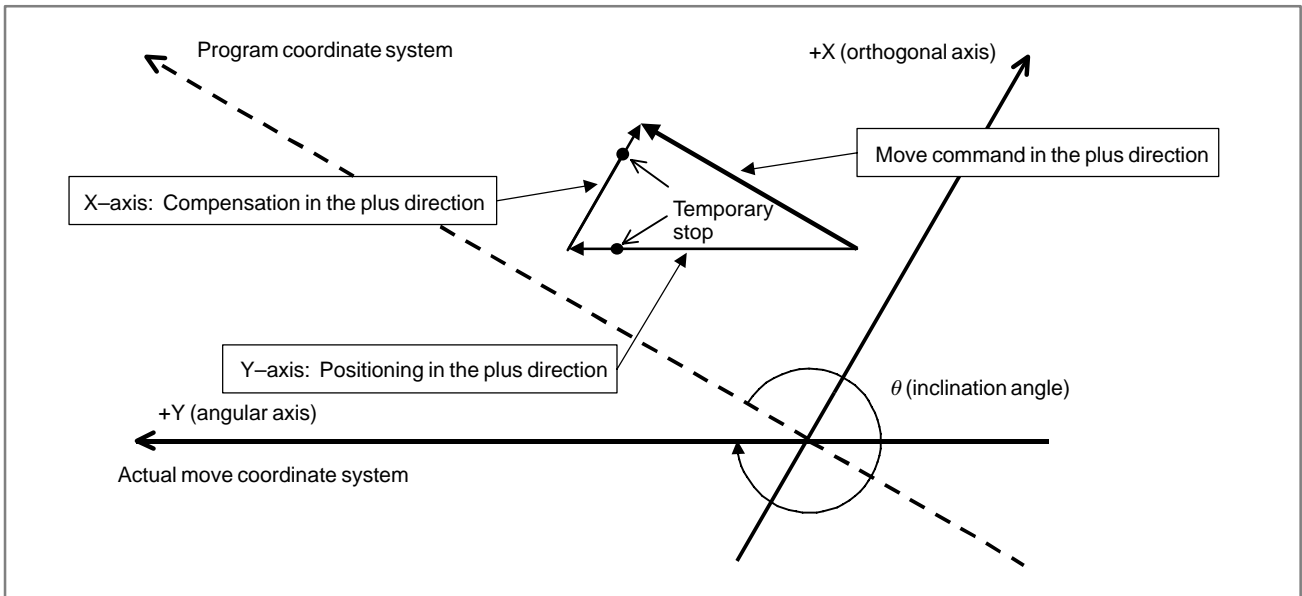

Move command in the plus direction

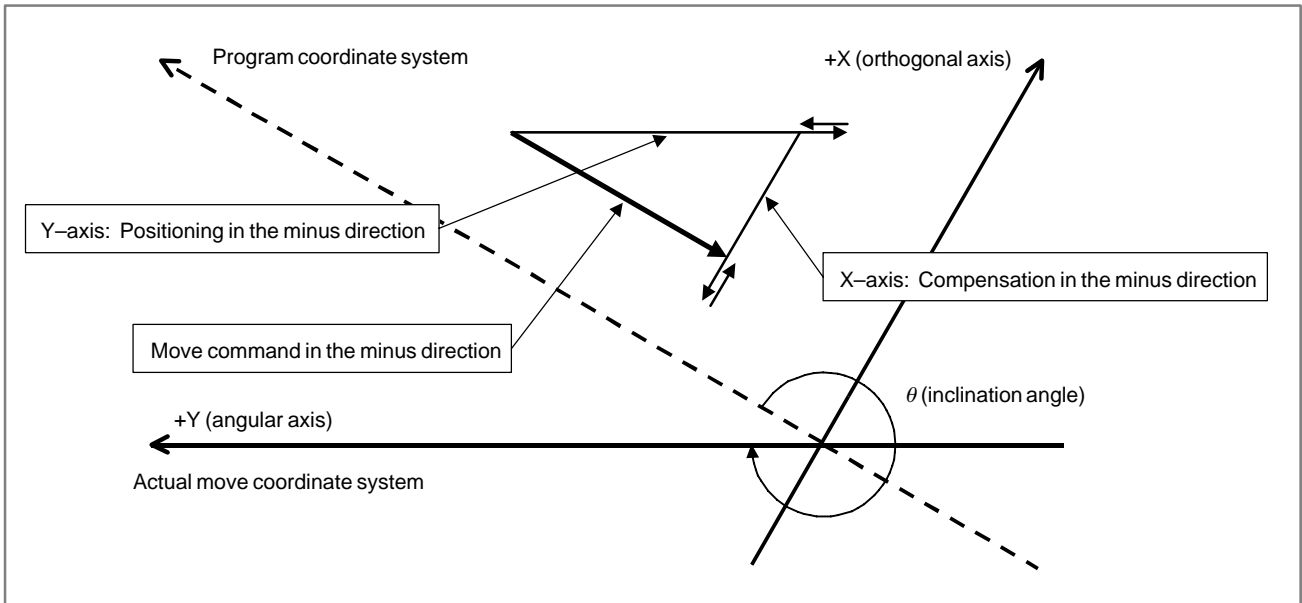

Move command in the minus direction

Reference item

Series 16i/18i/160i/180i/ 160is/180is	OPERATOR'S MANUAL (For Machining Center) (B-63534EN)	II.4.2	Single direction positioning
	OPERATOR'S MANUAL (For Lathe) (B-63524EN)	II.4.2	Single direction positioning
Series 21i/210i/210is	OPERATOR'S MANUAL (For Machining Center) (B-63614EN)	II.4.2	Single direction positioning
	OPERATOR'S MANUAL (For Lathe) (B-63604EN)	II.4.2	Single direction positioning
Series 20i	OPERATOR'S MANUAL (For Manual Milling Machine) (B-64204EN)	II.4.2	Single direction positioning

6.6 HELICAL INTERPOLATION

General

Helical interpolation is enabled by specifying up to two other axes which move synchronously with the circular interpolation by circular commands.

The command method is to simply add one or two move command axes which are not circular interpolation axes. An F command specifies a feedrate along a circular arc. Therefore, the feedrate of the linear axis is as follows:

$$F \times \frac{\text{Length of linear axis}}{\text{Length of circular arc}}$$

Determine the feedrate so that the linear axis feedrate does not exceed any of the various limit values.

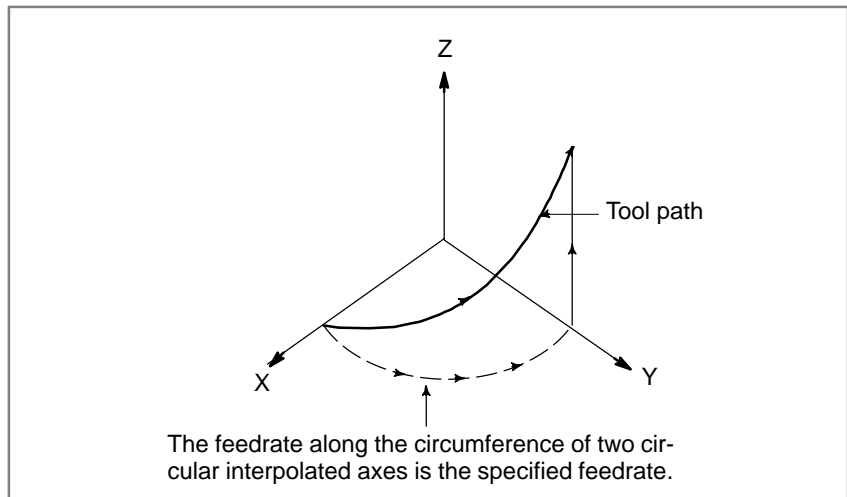

Parameter

	#7	#6	#5	#4	#3	#2	#1	#0
1404								HFC

HFC The feedrate for helical interpolation is:

- 0 : Clamped so that the feedrates along an arc and linear axis do not exceed the maximum cutting feedrate specified by parameter.
- 1 : Clamped so that the composite feedrate along an arc and linear axis does not exceed the maximum cutting feedrate specified by parameter.

When HFC is 1, and two linear axes exist, the combined feedrate for the four axes (two axes (arc) + two axes (straight line)) is clamped so that it does not exceed the maximum cutting feedrate.

<Parameters used for clamping>

When HFC is 0

No. 1430: Maximum cutting feedrate for each axis

Since the cutting feedrate for the arc is clamped to the above parameter value, the feedrate along the linear axis is clamped to the smaller parameter value.

Example: No. 1430 X 1000
Y 1200
Z 1400

G17 G03 X0. Y100. R100. Z1000. F5000;

The feedrate along the linear axis is clamped to 1000.

No. 1422: Maximum cutting feedrate (common to all axes)

If parameter No. 1430 is set to 0, the feedrate is clamped to the value set in this parameter.

When HFC is 1

No. 1422: Maximum cutting feedrate (common to all axes)

The cutting feedrate is clamped to the value set in this parameter. The value set with parameter No. 1430 is ignored.

Alarm and message

If more than two axes are specified together with the two axes for circular interpolation in a block specifying a helical interpolation operation, P/S alarm No. 232 is issued.

No.	Message	Description
0232	TOO MANY HELICAL AXIS COMMANDS	Three or more axes are specified as helical axes.

Reference item

Series 16i/18i/160i/180i/ 160is/180is	OPERATOR'S MANUAL (For Machining Center) (B-63534EN)	II.4.5	Helical Interpolation
	OPERATOR'S MANUAL (For Lathe) (B-63524EN)	II.4.5	Helical Interpolation
Series 21i/210i/210is	OPERATOR'S MANUAL (For Machining Center) (B-63614EN)	II.4.5	Helical Interpolation
Series 20i	OPERATOR'S MANUAL (For Manual Milling Machine) (B-64204EN)	II.4.5	Helical Interpolation

6.7 INVOLUTE INTERPOLATION (M SERIES)

General

With the involute interpolation function, an involute curve can be machined. Cutter compensation C is also possible. The use of involute interpolation eliminates the need to use short lines or arcs to approximate an involute curve. Pulse distribution is no longer interrupted by the high-speed operation of small blocks. As a result, smooth, high-speed operation is possible. In addition, part programs can be created more easily, and the required paper tape can be shortened.

Involute interpolation automatic feedrate control

Involute interpolation automatic feedrate control is a function that produces a cutting surface of higher machining precision by applying the following two overrides automatically to a specified feedrate during involute interpolation:

- Override at the time of cutter compensation inside offsetting
- Override in the neighborhood of a basic circle

(a) Override at the time of cutter compensation inside offsetting

When cutter compensation is applied to involute interpolation, control is exercised so that the tangential feedrate along the tool center path during normal involute interpolation is a specified feedrate at all times.

At this time, the feedrate of the outer point (cutting point) of the tool along the programmed path, that is, the actual cutting feedrate changes because the curvature of an involute curve changes momentarily.

In particular, if the tool is offset inside an involute curve, the actual cutting feedrate becomes greater than a specified value as the tool gets closer to a basic circle.

For smooth machining, control should be exercised so that the actual cutting feedrate matches a specified feedrate. This function finds an override value that matches the curvature of a momentarily changing involute curve particularly during involute interpolation at the time of inside offsetting. This function then exercises control so that the actual cutting feedrate, that is, the tangential feedrate at a cutting point is a specified feedrate at all times.

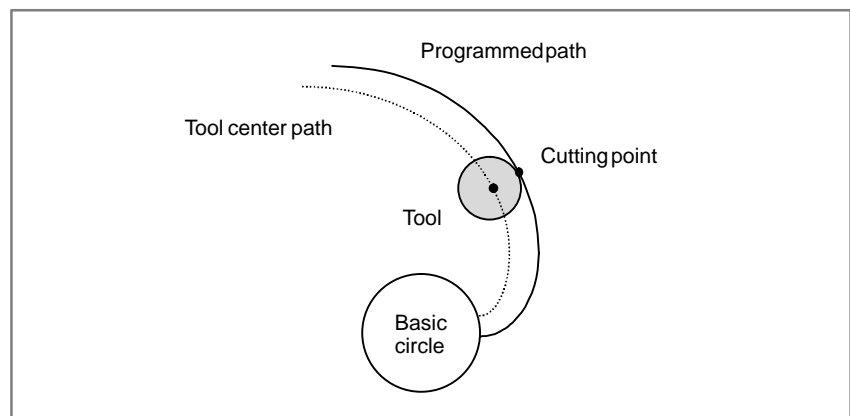

(b) Override in the neighborhood of a basic

If a programmed cutting feedrate is directly used in the neighborhood of a basic circle where the curvature of an involute curve changes relatively sharply, the cutter may be overloaded, resulting in a failure to produce a satisfactory cutting surface.

With this function, the movement of the tool is automatically decelerated according to the setting of a parameter in the neighborhood of a basic circle where the curvature of an involute curve changes relatively sharply, so that the load on the cutter is reduced to produce a satisfactory cutting surface.

Parameter

5610	Limit of initial permissible error during involute interpolation
------	--

[Data type] Two-word

[Unit of data]	Increment system	IS-A	IS-B	IS-C	Unit
	Metric input	0.01	0.001	0.0001	mm
	Inch input	0.001	0.0001	0.00001	inch

[Valid data range] 0 to 99999999

This parameter sets the allowable limit of deviation between an involute curve passing through a start point and an involute curve passing through an end point for an involute interpolation command.

5611	Radius (RIm+1) of curvature at cutting point for starting basic circle neighborhood override 1
------	--

5612	Radius (RIm+2) of curvature at cutting point for starting basic circle neighborhood override 2
------	--

5613	Radius (RIm+3) of curvature at cutting point for starting basic circle neighborhood override 3
------	--

5614	Radius (RIm+4) of curvature at cutting point for starting basic circle neighborhood override 4
------	--

5615	Radius (RIm+5) of curvature at cutting point for starting basic circle neighborhood override 5
------	--

[Data type] 2-word

[Unit of data]	Increment system	IS-B	IS-C	Units
	Metric input	0.001	0.0001	mm
	Inch input	0.0001	0.00001	inch

[Valid data range] 1 to 99999999

5616	Override value (OVR2) for starting basic circle neighborhood override 2
5617	Override value (OVR3) for starting basic circle neighborhood override 3
5618	Override value (OVR4) for starting basic circle neighborhood override 4
5619	Override value (OVR5) for starting basic circle neighborhood override 5
5620	Lower override limit (OVRLo) during involute interpolation

[Data type] Byte

[Unit of data] %

[Valid data range] 1 to 100

Set the override function based on a curvature radius. The curvature radiuses Rlmt1, Rlmt2, Rlmt3, Rlmt4, and Rlmt5, and the override values OVR2, OVR3, OVR4, and OVR5 must have the relationships indicated below. If the following relationships are not satisfied, this function does not operate:

$$Rlmt1 > Rlmt2 > Rlmt3 > Rlmt4 > Rlmt5 > 0$$

$$100\% > OVR2 > OVR3 > OVR4 > OVR5 > 0\%$$

Alarm and message

No.	Message	Description
241	END POINT, I, J, K, AND R ARE MISSING	The end point of an involute curve, I, J, or K is not specified.
242	SPECIFICATION ERROR (INVOLUTE)	An illegal value is specified for involute interpolation. (1)The specified start point or end point is located inside the base circle. (2)Zero is specified for I, J, K, or R. (3)The start point or end point is located more than 100 turns from the beginning of the involute curve.
243	END POINT NOT ON INVOLUTE CURVE	The end point is not on the involute curve that passes through the start point, and is beyond the range specified with in parameter No. 5610.

Reference item

Series 16i/18i/160i/180i/ 160is/180is	OPERATOR'S MANUAL (For Machining Center) (B-63534EN)	II.4.10	Involute Interpolation
---	--	---------	------------------------

6.8 POLAR COORDINATE INTERPOLATION

General

Polar coordinate interpolation is a function that exercises contour control in converting a command programmed in a Cartesian coordinate system to the movement of a linear axis (movement of a tool) and the movement of a rotary axis (rotation of a workpiece). This function is useful for grinding a cam shaft.

Explanations

G12.1 starts the polar coordinate interpolation mode and selects a polar coordinate interpolation plane (Fig. 6.8). Polar coordinate interpolation is performed on this plane.

- **Polar coordinate interpolation plane**

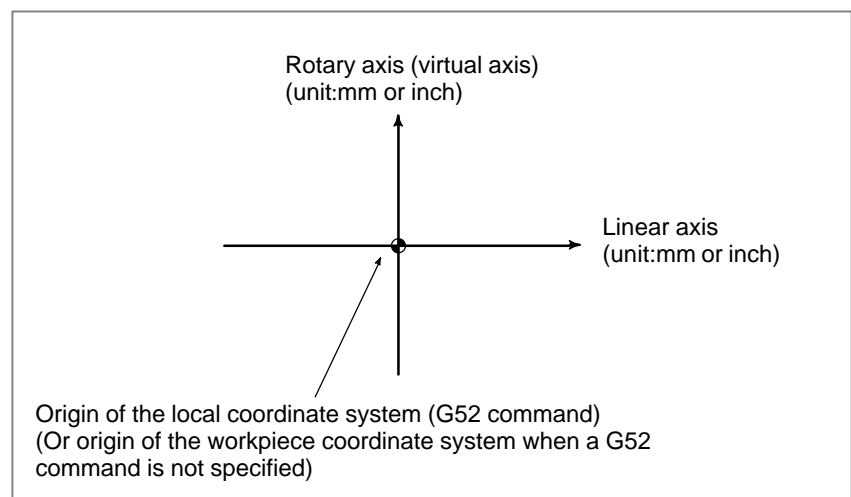

Fig. 6.8 Polar coordinate interpolation plane

When the power is turned on or the system is reset, polar coordinate interpolation is canceled (G13.1).

The linear and rotation axes for polar coordinate interpolation must be set in parameters (No. 5460 and 5461) beforehand.

Parameter

1422	Maximum cutting feedrate for all axes
------	---------------------------------------

[Data type] Two-word

[Unit of data]

[Valid data range]

Increment system	Unit of data	Valid data range	
		IS-A, IS-B	IS-C
Millimeter machine	1 mm/min	6 – 240000	6 – 100000
Inch machine	0.1 inch/min	6 – 96000	6 – 48000

Specify the maximum cutting feedrate.

A feedrate in the tangential direction is clamped in cutting feed so that it does not exceed the feedrate specified in this parameter.

NOTE

In M series, to specify the maximum cutting feedrate for each axis, use parameter No. 1430 instead.

5460	Axis (linear axis) specification for polar coordinate interpolation
------	---

5461	Axis (rotary axis) specification for polar coordinate interpolation
------	---

[Data type] Byte

[Valid data range] 1, 2, 3, ... control axes count

These parameters set control axis numbers of linear and rotary axes to execute polar interpolation.

5462	Maximum cutting feedrate during polar coordinate interpolation
------	--

[Data type] Two-word

[Unit of data]

[Valid data range]

Increment system	Unit of data	Valid data range	
		IS-A, IS-B	IS-C
Millimeter machine	1 mm/min	0, 6 – 240000	0, 6 – 100000
Inch machine	0.1 inch/min	0, 6 – 96000	0, 6 – 48000
Rotation axis	1 deg/min	0, 6 – 240000	0, 6 – 100000

This parameter sets the upper limit of the cutting feedrate that is effective during polar coordinate interpolation. If a feedrate greater than the maximum feedrate is specified during polar coordinate interpolation, it is clamped to the feedrate specified by the parameter. When the setting is 0, the feedrate during polar coordinate interpolation is clamped to the maximum cutting feedrate usually specified with parameter 1422.

Alarm and message

No.	Message	Description
145	ILLEGAL CONDITIONS IN POLAR COORDINATE INTERPOLATION	<p>The conditions are incorrect when the polar coordinate interpolation starts or it is canceled.</p> <p>1) In modes other than G40, G12.1/G13.1 was specified.</p> <p>2) An error is found in the plane selection. Parameters No. 5460 and No. 5461 are incorrectly specified.</p> <p>Modify the value of program or parameter.</p>

Reference item

Series 16i/18i/160i/180i/ 160is/180is	OPERATOR'S MANUAL (For Machining Center) (B-63534EN)	II.4.8	Polar Coordinate Interpolation
	OPERATOR'S MANUAL (For Lathe) (B-63524EN)	II.4.5	Polar Coordinate Interpolation
Series 21i/210i/210is	OPERATOR'S MANUAL (For Lathe) (B-63604EN)	II.4.4	Polar Coordinate Interpolation

6.9 CYLINDRICAL INTERPOLATION

General

The amount of travel of a rotary axis specified by an angle is internally converted to a distance of a linear axis along the outer surface so that linear interpolation or circular interpolation can be performed with another axis. After interpolation, such a distance is converted back to the amount of travel of the rotary axis.

The cylindrical interpolation function allows the side of a cylinder to be developed for programming. So programs such as a program for cylindrical cam grooving can be created very easily.

Use parameter No. 1022 to specify whether the rotation axis is the X-, Y-, or Z-axis, or an axis parallel to one of these axes.

Only one rotation axis can be set for cylindrical interpolation.

Parameter

	#7	#6	#5	#4	#3	#2	#1	#0
1006							ROSx	ROTx

NOTE

When this parameter is changed, turn off the power before continuing operation.

[Data type] Bit axis

ROTx, ROSx Setting linear or rotation axis

ROSx	ROTx	Description
0	0	Linear axis <ul style="list-style-type: none"> Inch/metric conversion is done. All coordinate values are linear axis type. (Not rounded in 0 to 360°) Stored pitch error compensation is linear axis type (Refer to parameter No. 3624)
0	1	Rotation axis (A type) <ul style="list-style-type: none"> Inch/metric conversion is not done. Machine coordinate values are rounded in 0 to 360° Absolute coordinate values and relative coordinate values are rounded or not rounded by parameter No. 1008#0 and #2. Stored pitch error compensation is the rotation type (Refer to parameter No. 3624) Automatic reference position return (G28, G30) is done in the reference position return direction and the move amount does not exceed one rotation.
1	0	Setting is invalid (unused)
1	1	Rotation axis (B type) <ul style="list-style-type: none"> Inch/metric conversion is not done. Machine coordinate values is linear axis type (Is not rounded in 0 to 360°). Absolute coordinate values and relative coordinate values are rounded or not rounded by parameter No. 1008#0 and #2. Stored pitch error compensation is linear axis type (Refer to parameter No. 3624). Cannot be used with the rotation axis roll over function and the index table indexing function (M series).

1022

Setting of each axis in the basic coordinate system

[Data type] Byte axis

To determine the following planes used for circular interpolation, cutter compensation C (for the M series), tool nose radius compensation (for the T series), etc., each control axis is set to one of the basic three axes X, Y, and Z, or an axis parallel to the X, Y, or Z axis.

G17: Plane Xp–Yp

G18: Plane Zp–Xp

G19: Plane Yp–Zp

Only one axis can be set for each of the three basic axes X, Y, and Z, but two or more parallel axes can be set.

Set value	Meaning
0	Neither the basic three axes nor a parallel axis
1	X axis of the basic three axes
2	Y axis of the basic three axes
3	Z axis of the basic three axes
5	Axis parallel to the X axis
6	Axis parallel to the Y axis
7	Axis parallel to the Z axis

Alarm and message

Number	Message	Description
175	ILLEGAL G107 COMMAND	Conditions when performing cylindrical interpolation start or cancel not correct. To change the mode to the cylindrical interpolation mode, specify the command in a format of "G07.1 rotation-axis name radius of cylinder."
176	IMPROPER G-CODE IN G107	Any of the following G codes which cannot be specified in the cylindrical interpolation mode was specified. 1) G codes for positioning, such as G28, G76, G81 – G89, including the codes specifying the rapid traverse cycle 2) G codes for setting a coordinate system: G50, G52 3) G code for selecting coordinate system: G53 G54–G59 Modify the program.

Reference item

Series 16 <i>i</i> /18 <i>i</i> /160 <i>i</i> /180 <i>i</i> / 160 <i>is</i> /180 <i>is</i>	OPERATOR'S MANUAL (For Machining Center) (B-63534EN)	II.4.9	Cylindrical Interpolation
	OPERATOR'S MANUAL (For Lathe) (B-63524EN)	II.4.7	Cylindrical Interpolation
Series 21 <i>i</i> /210 <i>i</i> /210 <i>is</i>	OPERATOR'S MANUAL (For Machining Center) (B-63614EN)	II.4.6	Cylindrical Interpolation
	OPERATOR'S MANUAL (For Lathe) (B-63604EN)	II.4.5	Cylindrical Interpolation

6.10 CYLINDRICAL INTERPOLATION CUTTING POINT COMPENSATION (M SERIES)

General

The conventional cylindrical interpolation function controls the movement of the tool center so that the tool axis moves along a specified path on the cylindrical surface to always face toward the rotation axis of the workpiece (cylindrical axis).

On the other hand, the cylindrical interpolation cutting point control function controls the tool so that the tangent from the tool to the cutting face of a contour figure passes the rotation center of the workpiece at all times.

This function is enabled in the AI high-precision contour control mode or in the AI nano high-precision contour control mode.

As shown in Fig. 6.10, control is exercised in the offset axis (Y-axis) direction normal to the tool, tool center axis, and workpiece rotation center axis.

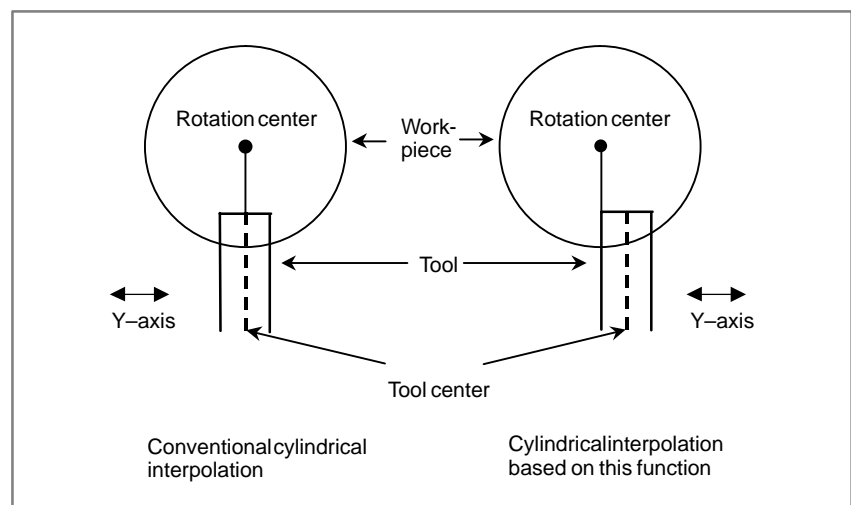

Fig. 6.10 Conventional cylindrical interpolation

RISC processor is necessary, if this function is used. Refer to Subsection 7.1.19 “RISC Processor Operation,” in this manual too.

Format

[G05 P10000 ; AI high-precision contour control mode ON]

:

**G07.1 IPr ; Starts the cylindrical interpolation mode
(enables cylindrical interpolation).**

:

:

G07.1 IP0 ; Cancels the cylindrical interpolation mode.

[G05 P0 ; AI high-precision contour control mode OFF]

IP One rotation axis address

r Radius of the cylinder of the rotation axis

Specify G07.1 IPr; and G07.1 IP0; in a single block.

G107 cannot be used.

Supplement: This function is enabled in the AI high-precision contour control mode or AI nano high-precision contour control mode. So, turn on and off this function in one of these modes.

Parameter

	#7	#6	#5	#4	#3	#2	#1	#0
1006								ROT

[Input type] Parameter input

[Data type] Bit axis

ROT Set whether the axis is:

0 : Axis that requires inch/metric switching (linear axis).

1 : Axis that does not require inch/metric switching (rotation axis).

Set this parameter to 1 for a rotation axis to which cylindrical interpolation is to be applied.

1022	Setting of each axis in the basic coordinate system
------	---

[Input type] Parameter input

[Data type] Integer axis

To determine the following planes used for circular interpolation, cutter compensation C (for the M series), tool nose radius compensation (for the T series), etc., each control axis is set to one of the basic three axes X, Y, and Z, or an axis parallel to the X, Y, or Z axis.

G17: Plane X_p-Y_p

G18: Plane Z_p-X_p

G19: Plane Y_p-Z_p

Only one axis can be set for each of the three basic axes X, Y, and Z, but two or more parallel axes can be set.

Set value	Meaning
0	Neither the basic three axes nor a parallel axis
1	X axis of the basic three axes
2	Y axis of the basic three axes
3	Z axis of the basic three axes
5	Axis parallel to the X axis
6	Axis parallel to the Y axis
7	Axis parallel to the Z axis

1260	Amount of a shift per one rotation of a rotation axis
------	---

[Input type] Parameter input

[Data type] 2-word axis

[Unit of data]	Increment system	Unit of data	Standard value
	IS-B	0.001 deg	360000
	IS-C	0.0001 deg	3600000

[Valid data range] 100 to 99999999

Set the amount of a shift per one rotaion of a rotaion axis.
Set the standard value for an axis to which cylindrical interpolation is to be applied.

	#7	#6	#5	#4	#3	#2	#1	#0
19530		CYS	CYA					

[Input type] Parameter input

[Data type] Bit

CYA Specify whether to perform cylindrical interpolation cutting point compensation with the cylindrical interpolation command (G7.1) in the AI high-precision contour control mode.

0 : Does not perform cylindrical interpolation cutting point compensation.

1 : Performs cylindrical interpolation cutting point compensation.

CYS When the cylindrical interpolation cutting point compensation function is used:

0 : Cutting point compensation is performed between blocks.

1 : Cutting point compensation is performed together with the movement of the block if the cutting point compensation value is less than the value set in parameter No. 19534.

19531	Tool offset axis number for the X-Y plane
-------	---

[Input type] Parameter input

[Data type] Word

[Valid data range] 1 to Number of controlled axes

Specify a tool offset axis that is normal to the cylindrical rotation axis.

19532

Tool offset axis number for the Z–X plane

[Input type] Parameter input**[Data type]** Word**[Valid data range]** 1 to Number of controlled axes

Specify a tool offset axis that is normal to the cylindrical rotation axis.

19533

Tool offset axis number for the Y–Z plane

[Input type] Parameter input**[Data type]** Word**[Valid data range]** 1 to Number of controlled axes

Specify a tool offset axis that is normal to the cylindrical rotation axis.

19534

Limit value when a change is made to cylindrical interpolation cutting point compensation in a single block

[Input type] Parameter input**[Data type]** Two–word**[Unit of data]** mm, inch (input unit)**[Valid data range]** 1 to 999999999

This parameter functions according to the setting of parameter No. 19530 as described below.

1) When $CYS = 0$

If the cylindrical interpolation cutting point compensation value is less than the setting of this parameter, cylindrical interpolation cutting point compensation is not performed. The ignored cylindrical interpolation cutting point compensation value is added to the next cylindrical interpolation cutting point compensation value to determine whether to perform cylindrical interpolation cutting point compensation.

2) When $CYS = 1$

If the cylindrical interpolation cutting point compensation value is less than the setting of this parameter, cylindrical interpolation cutting point compensation is performed together with the movement of the specified block.

NOTE

Set the following value in this parameter:

Setting > (setting of a rotation axis in parameter No. 1422)^{4/3}

The fraction "4/3" is a constant used for internal processing.

19535

Limit travel distance value for executing cylindrical interpolation cutting point compensation of the previous block without modification

[Input type] Parameter input

[Data type] Two-word

[Unit of data] mm, inch (input unit)

[Valid data range] 1 to 99999999

This parameter functions according to the type of interpolation as described below.

1) In the case of linear interpolation

If the travel distance of the specified block is less than the value set in this parameter, cylindrical interpolation cutting point compensation of the previous block is executed without modification.

2) In the case of circular interpolation

If the diameter of a specified arc is less than the value set in this parameter, cylindrical interpolation cutting point compensation of the previous block is executed without modification. Cylindrical interpolation cutting point compensation dependent on the movement of the arc is not performed.

Alarm and message

Number	Message	Description
0015	TOO MANY AXES COMMANDED	More move commands than the number of simultaneously controllable axes were specified. Add the option for extending the number of simultaneously controllable axes, or specify the move axes specified in the program in two blocks.
0175	ILLEGAL G107 COMMAND	An axis to which cylindrical interpolation cannot be applied was specified. A G07.1 block specifies two axes or more. In an attempt to cancel cylindrical interpolation, an axis not placed in the cylindrical interpolation mode was specified. When specifying an arc with cylindrical interpolation axes including a rotation axis (set bit 0 (ROT) of parameter No. 1006 = 1, and set parameter No. 1260), set not 0 but 5, 6, or 7 for parallel axis specification in parameter No. 1022.
0176	IMPROPER G-CODE IN G107	A G code not usable in the cylindrical interpolation mode was specified. This alarm is issued if the G code of group 01 is in the G00 mode or G00 is specified. Before specifying G00, cancel the cylindrical interpolation mode.

Reference item

Connection manual (This function)	7.1.19	RISC Processor Operation
--------------------------------------	--------	--------------------------

6.11 POLYGONAL TURNING (T SERIES)

Polygonal turning means machining a polygonal figure by rotating the workpiece and tool at a certain ratio.

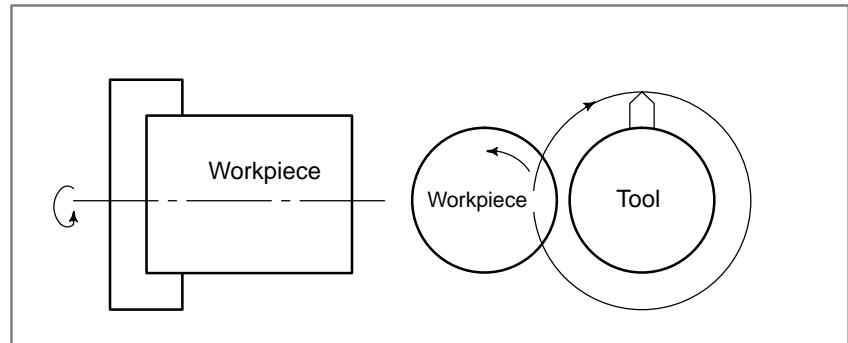

Fig. 6.11 (a) Polygonal turning

By changing conditions which are rotation ratio of workpiece and tool and number of cutters, the machining figure can be changed to a square or hexagon. The machining time can be reduced as compared with polygonal figure machining using C and X axes of the polar coordinate. The machined figure however, is not exactly polygonal. Generally, polygonal turning is used for the heads of square and/or hexagon bolts or hexagon nuts.

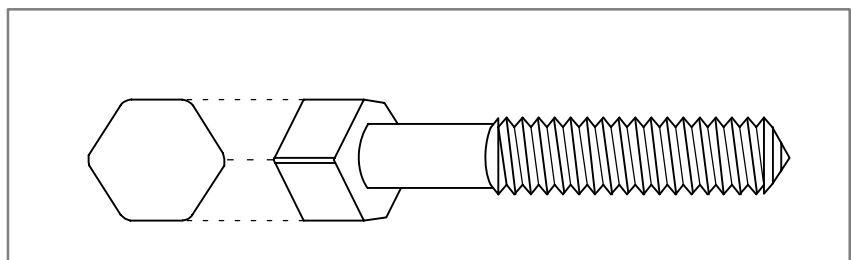

Fig. 6.11 (b) Hexagon bolt

This function controls the workpiece (spindle) and tool (rotation tool axis) so that the relationship between the spindle speed and tool speed is maintained at a constant ratio specified in a command given to the CNC.

(For the principle of polygonal turning, refer to Section 20.1, Part II of the “Operator’s Manual (For Lathe).”)

Either of the following can be selected as the tool rotation axis:

- CNC controlled axis (servo axis)
- Second spindle (with two serial spindles connected)

In the following descriptions, the term polygonal turning refers to a turning operation in which a servo axis is used as the tool rotation axis (See Section 6.11.1.).

The term polygonal turning with two spindle refers to a turning operation in which the second spindle is used as the tool rotation axis (See Section 6.11.2.).

6.11.1 Polygonal Turning

General

One of the axes (servo axes) controlled by the CNC is assigned as a tool rotation axis. Either serial spindle or analog spindle can be used as a workpiece axis (spindle).

Polygonal turning using a servo axis is detailed in the operator's manual (for lathe).

This section focuses on supplementary information and examples for the connection.

• Spindle connection

A position coder must be mounted on the spindle. However, polygonal turning requires no additional changes to the spindle connection (See Section 9.3.).

Polygonal turning uses the position coder feedback signal to control the positional relationship (cutting position) between the spindle and tool rotation axis, and the ratio of speed.

• Tool rotation axis (servo axis) connection

Parameter No. 7610 specifies the controlled axis (servo axis) to be used as the tool rotation axis.

The same parameter setting as for ordinary servo axes applies to the servo axis connection for polygonal turning except for some parameters.

When the machine is not in the polygonal turning mode, the servo axis specified as the rotation tool axis functions as a feed axis. So, the servo axis can be:

- Used as a subspindle under PMC axis control
- Positioned by a move command from a machining program.

However, be careful about the angle to rotate through and feedrate. Read the operator's manual (for lathe) and the following examples.

• Examples of parameter setting

- The following descriptions exemplify typical parameter setting for polygonal turning using a serial pulse coder (with a million pulse capability).

→ The parameter setting described here is not a must for polygonal turning.

→ Specify typical values for parameters unless otherwise stated.

• Tool rotation axis setting

This example uses the CNC's fourth axis (connected as the Y-axis) as a rotation tool axis for polygonal turning.

Parameter No. 7610 = 4
(controlled axis number for the tool rotation axis)

The following description assumes that the axis type parameter is set to the fourth axis.

• Servo parameter setting

Set the servo parameters as listed below:

CMR = 1
DMR = 36/1000

(With the above setting, the reference counter capacity is 36000.)

Parameter No. 1820 = 2 (CMR)

Parameter No. 1821 = 36000 (reference counter capacity)

Parameter No. 2084 = 36 (DMR numerator)

Parameter No. 2085 = 1000 (DMR denominator)

For the other servo parameters, specify typical values.

- Parameter setting for polygonal turning

The least command increment, detection unit, the angle to rotate through per rotation for the polygon axis are as follows:

$$\text{Least command increment} = \frac{L \times \text{CMR}}{Q \times \text{DMR}}$$

$$\text{Detection unit} = \frac{\text{least command increment}}{\text{DMR}} = \frac{L}{Q \times \text{DMR}}$$

Angle to rotate through per tool axis rotation

$$= \frac{360}{\text{least command increment}}$$

where

L: Tool axis rotation angle per motor rotation (degrees),
(360 × speed increment ratio)

When the servo motor is connected directly to the rotation tool, for example, L = 360. When the tool speed is doubled, L = 720.

Q: Number of pulses per pulse coder rotation
(For a serial pulse coder, Q = 1000000.)

The least command increment specified here is specific to the polygon axis. It is determined regardless of what is specified in parameter No. 1004 (ISA/ISC). However, both ISA and ISC must be set to 0 for IS-B setting.

If the servo motor is connected directly to the rotation tool:

$$\text{Least command increment} = \frac{360 \times 1}{1000000 \times \frac{36}{1000}} = 0.01 \text{ (degrees)}$$

Detection unit = 0.01 (degrees)

$$\text{Angle to rotate through per tool axis rotation} = \frac{360}{0.01} = 36000 \text{ (degrees)}$$

The upper limit to the tool rotation axis speed is:

Maximum servo motor speed × speed increment ratio

Therefore, if the maximum servo motor speed is 2000 min⁻¹, and the servo motor is directly connected to the servo motor:

$$\text{Upper limit to the tool rotation axis speed} = 2000 \times 1 = 2000 \text{ (min}^{-1}\text{)}$$

This means the parameters must be set as follows:

No. 7620 = 36000 (angle to rotate through per tool axis rotation)

No. 7621 = 2000 (upper limit to tool rotation axis speed)

- Feedrate parameter setting

Because the least command increment is 0.01 degrees, the input unit for the feedrate is 10 degrees/min.

To obtain a rapid traverse speed of 2000 min⁻¹, for example, specify as follows:

$$\text{No. 1420} = 72000 \left(= 2000 \times \frac{360}{10} \right)$$

Also specify other feedrates in 10 degrees/min units.

- **Commands from the NC program**

When the machine is not performing polygonal turning, the machining program can issue move commands to the polygon axis.

Such commands can be issued in the same way as for ordinary axes. However, be careful about the angle to rotate through and feedrate.

Assuming the polygon axis is the Y-axis, the polygon axis rotates through 0.03 degrees by the following command:

V3;

Likewise, the polygon axis rotates through 10.00 degrees by the following command:

V1.0;

The feedrate unit is also increased by tenfold.

The current position of the polygon in the machine coordinate system is normalized according to the value specified by parameter No. 7620.

Typical values range from 0.000 to 35.999.

Signal

Polygon synchronization under way signal

PSYN

<F063#7>

[Classification] Output signal

[Function] Informs the PMC that the machine is in the polygon turning mode.

[Output condition] The polygon synchronization signal is set to logical “1” by the polygon turning mode command (G51.2) and stays at “1” during the polygonal turning mode.

The signal is reset to logical “0” by the polygon turning mode reset command (G50.2) or a reset. It stays at logical “0” when the machine is not in the polygonal turning mode.

CAUTION

This signal uses the same address for both polygonal turning (using the servo axis) and polygonal turning with two spindles.

· Other signals (related to the tool rotation axis)

→ Some signals related to the CNC controlled axis used as the tool rotation axis may be made ineffective depending on whether the machine is in the polygonal turning mode.

For these signals, read the note in operator’s manual (for lathe).

Signal address

	#7	#6	#5	#4	#3	#2	#1	#0
F063	PSYN							

Parameter

	#7	#6	#5	#4	#3	#2	#1	#0
7600	PLZ							

[Data type] Bit

PLZ Synchronous axis using G28 command

- 0: Returns to the reference position in the same sequence as the manual reference position return.
- 1: Returns to the reference position by positioning at a rapid traverse. The synchronous axis returns to the reference position in the same sequence as the manual reference position return when no return-to-reference position is performed after the power is turned on.

7610	Control axis number of tool rotation axis for polygon turning

[Data type] Byte

[Valid data range] 1, 2, 3, . . . number of control axes

This parameter sets the control axis number of a rotation tool axis used for polygon turning.

7620	Movement of tool rotation axis per revolution

[Data type] Two-word

Increment system	IS-A	IS-B	IS-C	Unit
Rotation axis	0.01	0.001	0.0001	deg

[Valid data range] 1 to 9999999

This parameter sets the movement of a tool rotation axis per revolution.

7621	Maximum allowable speed for the tool rotation axis (polygon synchronization axis)

[Data type] Word

[Unit of data] min⁻¹

[Valid data range] For polygonal turning using servo motors:

$$\frac{0 \text{ to } 1.2 \times 10^8}{\text{set value of the parameter No. 7620}}$$

This parameter sets the upper-limit rotation speed of a tool rotation axis. The rotation speed of the tool rotation axis is clamped by the upper-limit rotation speed during polygon turning. The spindle and tool rotation axis go out of synchronization when the rotation speed is clamped (P/S alarm No. 5018).

Alarm and message

Number	Message	Description
217	DUPLICATE G251 (COMMANDS)	G51.2 (or G251) is further commanded in the polygonal turning mode. Modify the program.
218	NOT FOUND P/Q COMMAND IN G251	P or Q is not commanded in the G51.2 (or the G251) block, or the command value is out of the range. Modify the program.
219	COMMAND G250/G251 INDEPENDENTLY	G51.2 (or G251) and G50.2 (or G250) are not independent blocks.
220	ILLEGAL COMMAND IN SYNCHR-MODE	In the synchronous operation, movement is commanded by the NC program or PMC axis control interface for the synchronous axis.
221	ILLEGAL COMMAND IN SYNCHR-MODE	Polygon machining synchronous operation and Cs contouring control or balance cutting are executed at a time. Modify the program.

Caution

CAUTION

- 1 Before issuing a G51.2, rotate the spindle. If it is not rotating when the G51.2 is issued, the program stops to wait for a one-rotation signal from the position coder on the spindle. This does not apply to a dry run.
- 2 A reset releases the polygonal turning mode.
- 3 Machine a workpiece at the same spindle speed until finish machining for the workpiece.

Reference item

Series 16i/18i/160i/180i/ 160is/180is	OPERATOR'S MANUAL (For Lathe) (B-63524EN)	II.19.1	POLYGONAL TURNING
Series 21i/210i/210is	OPERATOR'S MANUAL (For Lathe) (B-63604EN)	II.19.1	POLYGONAL TURNING

6.11.2 Polygonal Turning with Two Spindles

General

In a configuration where two or more serial spindles are used, spindle rotation control is applied to the workpiece rotation axis (master axis) and the tool rotation axis (polygon synchronization axis) with a certain ratio.

The polygonal turning with two spindles can use different spindle speeds for the same workpiece, because it performs automatic phase compensation when a polygon synchronization mode command is issued or the S command is changed during polygon synchronization mode. With this function, it is also possible to specify the phase difference between the master and polygon synchronization axes.

With a 2-path lathe, polygonal turning is possible on each tool post. The master axis and polygon synchronization axis function as the first spindle and second spindle, respectively. Moreover, arbitrary spindles can be selected as the master axis and polygon synchronization axis by setting parameter No. 7640 and parameter No. 7641. In this case, a spindle of a different path can be selected.

• Command format

The CNC command format for polygonal turning with two spindles is described below. For the CNC command format for polygonal turning (see Section 6.10.1), refer to the operator's manual (for lathe). The two formats are almost identical. The differences are that the polygonal turning with two spindles can specify a phase command (R) and re-issue commands.

• Mode command and command value change

◆ G51.2 P_Q_R_;

This command starts the polygon synchronization mode or changes the values specified for the polygon synchronization mode.

P: Master axis (first spindle) rotation ratio

Range of command value: Integer 1 to 999

(The direction in which the master axis rotates depends on the commands (such as M03 and M04) issued under ordinary spindle control.)

Q: Polygon synchronization axis (second spindle) rotation ratio

Range of command value: Integers 1 to 999 and -1 to -999

(The direction in which the polygon synchronization axis rotates depends on the algebraic sign of the Q value, except when bit 1 (GDRC) of parameter No. 7603 = 1, in which case the polygon synchronization axis rotates in the same direction as the first spindle. In this case, Q cannot take a negative value.)

R: Relative phase difference between the master and polygon synchronization axes

The range of command value and the increment system are the same as for the rotation axis. However, the angle to rotate through is in 360/4096 degrees units.

(R is omissible. If it is not specified at all, the phase difference is assumed to be 0. If bit 5 (PCOF) of parameter No. 7602 = 1 to disable phase control, the R command is ignored, but no alarm condition is assumed.)

The G51.2 command is modal. Once specified, the P, Q, and R values stay unchanged until another G51.2 is issued to change them or polygon synchronized mode is released.

The S command issued to the first spindle during polygon synchronization mode specifies that the second spindle be used as a polygon synchronization axis and rotates at a speed of $S \times Q/P$ with a phase difference of R.

- **Release command**

- ◆ **G50.2**

This command releases the polygon synchronization mode. This mode is released also when:

- (1) Reset

(That mode is not released by bit 0 (RPLM) of parameter No. 7603.)

- (2) Power is turning off.

- (3) An alarm condition occurs in the spindle control unit, and the serial spindle control unit stops in an emergency on the PMC signals *ESPA<G0071#1> and *ESPB<G0075#1>.

- (4) P/S alarm 218, 219, or 221 occurs

- **Cautions for using commands**

G51.2 and G50.2 must be issued separately from other commands.

In a G51.2 issued to enter the polygon synchronization mode, R is omissible, but P and Q are required.

After a G51.2 is issued to enter the polygon synchronization mode, changing modal values of P, Q, and R requires another G51.2. In this case, R can be specified separately from P and Q. However, P and Q must be specified together even if only one of them is changed.

- **Spindle operation during the spindle–spindle polygon synchronization mode**

When a G51.2 is issued to start the spindle–spindle polygon synchronization mode, the speed of the spindle (polygon synchronization axis) is changed to Q/P times the speed of the first spindle (master axis) to achieve a speed ratio of P:Q, and phase adjustment is performed.

(If no S command is issued to the first spindle after a G51.2, the previous S command remains effective.)

If the spindle is in an acceleration, deceleration, or phase adjustment state, synchronization at a rotation ratio of P:Q is not guaranteed. So, it is necessary to control SAR<G0029#4> by checking the speed arrival signal PSAR<F0063#2> for polygonal turning with two spindles or to allow sufficient time in the program.

The method to specify the spindle speed during the polygon synchronization mode is the same as for ordinary modes. However, each time an S command is issued to the first spindle during polygon synchronization mode, or a rotation ratio P:Q or phase value R command is re-specified during the polygon synchronization mode, phase adjustment is performed after speed control. In addition, speed commands (such as under multi-spindle control or spindle output control for the second spindle by the PMC) for the second spindle become ineffective.

If the specified polygon synchronization axis speed ($S \times Q/P$ for the first spindle at S rpm) exceeds the clamp speed specified in parameter No. 7621, the polygon synchronization axis speed is clamped, and P/S alarm No. 5018 is issued.

Each time the spindle speed command for the first spindle changes or P and Q are re-specified in a G51.2, the clamp speed is checked to determine whether to issue P/S alarm No. 5018.

Note that a reset can clear the alarm with the speed clamped.

(A rotation speed ratio of $P:Q$ cannot be maintained with the speed clamped. Bit 2 (QCL) of DGN No. 471 indicates whether the speed is clamped.)

- **PMC sequence**

Although this function is based on the G-code system, it is necessary to add or change PMC ladder sequences because control on the part of the spindle is also required (See signals in Section 6.10.2).

- **Example of polygonal turning with two spindles**

This example of polygonal turning with two spindles produces a square using single-edged cutting tools (for roughing and finishing).

.		
M0□;	Step 1.	Mount a roughing tool on the polygon synchronization axis (second spindle as tool rotation axis).
T○○△△ ;		
G00 X100. Z20. M03 S1000 ;	Step 2.	Rotate the workpiece (with the first spindle as the master axis at 1000 min^{-1})
.		
.		
G51.2 P1 Q2 ;	Step 3.	Start rotating the tool.
.		Energize the second spindle in response to the polygon synchronization under way signal using the PMC ladder.
.		After accelerating the second spindle as the polygon synchronization axis to 2000 rpm, perform phase adjustment (Execute R0 to omit an R value.).
.		By checking PSYC<F0063#7>, the PMC ladder can detect when the polygon synchronization mode is entered. During the polygon synchronization mode, the PMC ladder controls SAR<G0029#4> based on the speed arrival signal PSAR<F0063#2> during the polygon synchronization mode.
.		
.		
.		
.		
.		
G01 X80. F10. ;	Step 4.	Starts cutting along the X-axis after SAR<G0029#4> becomes logical 1 in signal control at step 3.
.		
.		
G04 P4000 ;	Step 5.	Polygonal turning (roughing 1)
.		
G00 X100. ;	Step 6.	Retract the tool along the X-axis.
.		
G51.2 R180 ;	Step 7.	Change the phase by 180 degrees.
.		
[Repeat steps 4, 5, and 6.]	Step 8.	Polygonal turning (roughing 2)
.		

- G50. 2 ;
MΔ□ ;
TΔΔ □□ ;
.
- Step 9. Release the polygon synchronization mode. Change to a finishing tool.
- G51. 2 P1 Q2 ;
S2000;
.
.
- Step 10. Change the spindle speed for finishing (master axis at 2000 min⁻¹ and polygon synchronization axis at 4000 min⁻¹ with a phase difference of 0).
- [Repeat steps 4, 5, and 6.]
- Step 11. Polygonal turning (finishing 1)
- [Repeat step 7.]
- Step 12. Change the phase by 180 degrees.
- [Repeat steps 4, 5, and 6.]
- Step 13. Polygonal turning (finishing 2)
- .
- .
- G50. 2 ;
.
.
.
- Step 14. Release the polygon synchronization mode. The polygon synchronization axis (second spindle as tool rotation axis) stops. The first spindle rotates at a speed specified by an S command.
- M05;
- Step 15. The first spindle stops (end).
- .
- .

- **Diagnosis display (DGN)** For polygonal turning with two spindles, the following information is displayed on the diagnosis display screen.

Polygonal turning with two spindles Indication of information about the polygon synchronization mode

DGN	#7	#6	#5	#4	#3	#2	#1	#0
470	SC0	LGE		SCF			PST	SPL

- SPL** Spindle–spindle polygon synchronization under way
- PST** Spindle–spindle polygon synchronization mode being activated
- #2** Spindle–spindle polygon synchronization mode released
- #3** Spindle speed being changed during spindle–spindle polygon synchronization mode
- SCF** Spindle speed changed during spindle–spindle polygon synchronization mode
- #5** Not used
- LGE** The loop gain is different between the spindles during spindle–spindle polygon synchronization mode.
- SC0** Actual speed command is 0 during spindle–spindle polygon synchronization mode.

CAUTION

1 DGN indicates the loop gain because this function requires that both spindles be controlled with the same loop gain. However, no alarm is issued even if the loop gain is different between the spindles.

(For the serial spindle control unit, the parameters used are changed according to the state of the CTH1 and CTH2 signals.)

2 SC0 is not a value specified by the program. It is set to 1 under any of the following conditions:

1. When the S command value is adjusted according to the signals related to spindle control, SSTP<G0029#6> and SOV0– SOV7<G0030> and the signal related to multi-spindle control <G0027>, the result is 0.

2. The S command value is smaller than the spindle control resolution (the result of multiplying the S command value by a value of 4095/(maximum spindle speed) is less than 1).

The S command value is specified by SIND control <G0032, G0033>, and it is 0.

If SC0 = 1, the spindle speed becomes 0 and bit 0 of DGN No. 471 becomes 1. In this case, the polygon synchronization rotation ratio is impractical, but P/S alarm No. 5018 does not occur, because it is regarded as the result of the command.

NOTE

1 The normal state during spindle-spindle polygonal turning is: SPL = 1, SCF = 1, #1 = 0, #2 = 0, and #3 = 0

2 If only PST becomes 1, but no change occurs, and the program stops in a block containing a G51.2 command, the speed of an spindle does not reach the targeted polygon synchronization speed, for example, because bit 7 (PST) of parameter No. 7603 = 0 keeps the spindle from being energized.

3 When the speed is changed during polygon synchronization mode, LGE is set to 1 if the spindle synchronization control loop gain used by the serial spindle control unit is different between the first and second spindles.

Polygonal turning with two spindles Indication of causes for P/S alarms 5018 and 218

DGN	#7	#6	#5	#4	#3	#2	#1	#0
471	NPQ	PQE		NSP	SUO	QCL	PCL	

#0 to #3 Causes for P/S alarm No. 5018

P/S alarm No. 5018 is cleared by a reset, but the indication of its causes remains until the causes are cleared or the polygon synchronization mode is released.

- #4 to #7** Causes for P/S alarm No. 218
When P/S alarm No. 218 occurs, the polygon synchronization mode is released, but the indication of its causes remains until the alarm is cleared by a reset.
- #0** The specified speed is too low during spindle–spindle polygon synchronization mode. (The unit of speed calculated internally becomes 0.)
- PCL** The first spindle (polygon synchronization master axis) is clamped.
- QCL** The second spindle (polygon synchronization axis) is clamped.
- SUO** The specified speed is too high during the spindle–spindle polygon synchronization mode. (It is clamped to the upper limit calculated internally.)
- NSP** A spindle necessary for control is not connected. (For example, there is not a serial spindle or the second spindle.)
- #5** When bit 1 (QDRC) of parameter No. 7603 = 1, a negative value is specified at Q.
- PQE** In a G51.2, either P or Q has a value out of the specifiable range.
Or, P and Q are not specified as a pair.
- NPQ** In a G51.2, R is specified when P and Q have not been specified at all, or none of P, Q, and R has been specified.

CAUTION

#0 becomes 1 also when the specified spindle speed is 0 (DGN 470#7 = 1). In this case, however, P/S alarm No. 5018 is not issued (because the command is 0). When DGN 470#7 = 0 and DGN 471#0 = 1, P/S alarm No. 5018 occurs. Normally this does not occur with speed at which the spindle can rotate.

NOTE

- 1 PCL indicates that the master axis has received a command with a speed that is higher than the value specified by the maximum first spindle speed parameters (No. 3741 to 3744) and is clamped to that speed. PCL will not become 1 as long as the first spindle is connected correctly.
- 2 QCL becomes 1, when the second spindle (polygon synchronization axis) receives a command with a polygon synchronization speed that is higher than the value specified in parameter No. 7621 and is clamped at that speed.
- 3 SUO occurs, if a result of (speed specified for the first spindle)/(value specified at P) is higher than 59998. In other words, the first spindle must rotate at a speed lower than 59998 min^{-1} assuming $P = 1$.

Indication of values specified during the spindle–spindle polygon synchronization mode

DGN

474

Rotation ratio for the master axis during the spindle–spindle polygon synchronization mode (P command value)

This indication is the current rotation ratio (P command value) of the master axis (first spindle) during the spindle–spindle polygon synchronization mode.

DGN

475

Rotation ratio for the polygon synchronization axis during the spindle–spindle polygon synchronization mode (Q command value)

This indication is the current rotation ratio (Q command value) of the polygon synchronization axis (second spindle) during the spindle–spindle polygon synchronization mode.

DGN

476

Phase difference between the two spindles under spindle–spindle polygon synchronization control (R command value)

This indication is the current phase value (R command value) specified during the spindle–spindle polygon synchronization mode. (The unit of measurement is the least increment system for the rotation axis of the machine.)

However, if bit 5 (RDGN) of parameter No. 7603 = 1, the indication is the amount of shifting specified for the serial spindle (number of pulses after conversion is performed assuming 360 degrees = 4096 pulses).

Indication of the actual speed of each spindle during the spindle–spindle polygon synchronization mode

DGN

477

Actual master axis speed (min^{-1}) during the spindle–spindle polygon synchronization mode

This indication is the actual speed of the master axis (first spindle) during the spindle–spindle polygon synchronization mode.

DGN

478

Actual polygon synchronization axis speed (min^{-1}) during the spindle–spindle polygon synchronization mode

This indication is the actual speed of the polygon synchronization axis (second spindle) during the spindle–spindle polygon synchronization mode.

NOTE

The indications of DGN No. 477 and 478 vary because of no sampling being performed. Consider these DGN values only guidelines.

Signal

Polygon synchronization under way signal PSYN<F063#7>

[Classification] Output signal

[Function] Informs the PMC that the system is in the polygon synchronization mode.

[Output condition] The polygon synchronization mode command (G51.2) sets this signal to logical “1”. It stays at “1” as long as the system is in the polygon synchronization mode. It is turned to “0” when the polygon synchronization mode is cleared (G50.2 command or a reset). It stays at “0” when the system is not in the polygon synchronization mode.

NOTE

The same address is used for this signal in both polygonal turning (using the servo axis) and the polygonal turning with two spindles.

Polygon spindle stop signal *PLSST<G038#0>

[Classification] Input signal

[Function] This function is enabled when bit 7 (PST) of parameter No. 7603 = 1. This signal is used to stop the spindle during the polygonal turning mode with two spindles.

“0” = polygon spindle stop

“1” = polygon spindle operable

During the polygonal turning mode with two spindles, the spindles are controlled with a positional loop set up. When issuing a spindle stop command (like M05) to deenergize the spindle, it is necessary to specify S = 0 using *SSTP<G00296#6>. Otherwise the motion command remains effective even after the spindle is deenergized. This error accumulates and causes a dangerous behavior of the spindle when it is energized again. This signal is intended to inhibit distribution of the S command to the spindle if it cannot be set to 0 while the spindle is deenergized. In such a case, the signal should be used in step with the energizing state of the polygon spindle.

**Spindle polygonal speed
arrival signal
PSAR<F063#2>**

[Classification] Output signal

[Function] Informs the PMC that the spindle has reached its constant-speed for polygon synchronization during polygonal turning with two spindles.

[Output condition] During polygonal turning mode with two spindles, whether the constant-speed is reached for polygon synchronization is output as shown below:
 “0” = not reached (during phase change or acceleration/deceleration under way)
 “1” = reached

During the polygon control mode, this signal becomes logical “1” when the speed of each spindle reaches the acceptable level specified in parameter No. 7631 and remains there for a period specified in parameter No. 7632.

If the speed of either spindle goes off the acceptable level, or a change is made to the S command, the signal returns to logical “0” and begins monitoring the above condition.

When this signal is “0”, the specified speed ratio and phase are not guaranteed for polygonal turning. If the signal is confirmed before actual turning is started, however, the operation is more efficient than when a dwell command (like G04) is used to allow wait time.

**Master axis not arrival
signal
PSE1<F063#0>
Polygon synchronization
axis not arrival signal
PSE2<F063#1>**

[Classification] Output signal

[Function] Informs the PMC whether the actual speed of each spindle has reached the specified speed during polygonal turning mode with two spindles.

[Output condition] During polygonal turning mode with two spindles, whether each spindle has reached the polygon synchronization speed is output as shown below:
 “0” = reached
 “1” = not reached (during phase change or acceleration/deceleration under way)

During the polygon control mode, this signal becomes logical “1” when the speed of master axis (first spindle) and polygon synchronization axis (second spindle) does not reach the acceptable level specified in parameter No. 7631.

- **PMC sequence**

When a G51.2 is issued to put the system in the polygon synchronization mode, the polygon synchronization under way signal PSYN<F063#7> turns on.

Set up a PMC sequence for the polygon synchronization mode by monitoring this signal with a PMC ladder.

There are two control methods, (A) and (B), to control energizing of the spindle. First select (A) or (B) and creates a PMC sequence according to the selected method.

Method A

(A)Energize the first and second spindles automatically during the G51.2 mode.

Basically, do not discontinue energizing during this mode.

In this case, keep bit 7 (PST) of parameter No. 7603 = 0.

In the PMC sequence, detect when the polygon synchronization under way signal PSYN<F063#7> changes from 0 to 1, then energize the first and second spindles.

The NC stops at the G51.2 command block which puts the system in the polygon synchronization mode, and remains there until the spindle reaches the polygon synchronization speed.

Also, keep the spindle energized, for example, by preventing it from receiving a spindle stop command (like M05) for ordinary spindle control while PSYN<F063#7> = 1. Basically, deenergize the spindle when the polygon synchronization under way signal PSYN<F063#7> changes from 1 to 0.

Method B

(B)Control the energizing of the spindle using M codes even during the G51.2 mode. Alternatively, deenergize the spindle even during the G51.2

In this case, keep bit 7 (PST) of parameter No. 7603 = 1.

This parameter setting enables use of the spindle stop signal *PLSST<G038#0> during the polygon synchronization mode. It also makes the G51.2 command block stop waiting for the spindle to reach the polygon synchronization speed.

In the PMC sequence, while the polygon synchronization under way signal PSYN<F063#7> = 1, set *PLSST<G038#0> to 1 after confirming both first spindle and second spindles are energized.

If either spindle has been deenergized, reset *PLSST<G038#0> to 0.

When the polygon synchronization under way signal PSYN<F063#7> changes from 1 to 0, basically keep *PLSST <G038#0> at 0. (This is intended to keep *PLSST <G038#0> from becoming 1 in a deenergized state when the polygon synchronization mode is entered again.)

When *PLSST <G038#0> changes from 0 to 1 during the polygon synchronization mode, the spindle is accelerated from a stop state to the specified speed and placed under phase control, even if the S command has not been changed.

Sequence common to methods (A) and (B)

Regardless of whether the method you use is (A) or (B), set up the PMC sequence as follows:

- Do not use the SFR/SRV signal to switch the rotation direction of the first spindle. Instead, fix the energizing method of the spindle at SFR and change the polarity of the command. (To change the polarity of the command, issue M03/M04 with bit 7 (TCW) of parameter No. 3706 = 1, or control SGN<G033#5> with SSIN<G033#6> = 1.)

Also fix the energizing method of the second spindle at SFR.

- To check whether the spindle has reached its constant-speed, control SAR<G029#4> using PSAR<F063#2>.

PSAR<F063#2> can be used to check whether both spindles have reached the conditions specified in parameter Nos. 7631 and 7632 after completion of phase control. Checking the speed arrival signal for each spindle (SARA<F045#3> and SARB<F049#3>) cannot guarantee proper cutting start conditions, because phase control may occur afterward.

The specification (parameter No. 3740) of time allowed before the spindle constant-speed reached signal is checked remains valid until after execution of the G51.2 command.

If you are not using SAR<G029#4> as the cutting feed start condition, start cutting after allowing time using the program (like G04) for both spindles to reach their constant speeds, when the polygon synchronization mode is entered and each time the S command is changed during the polygon synchronization mode.

- It is impossible to rotate the second spindle separately from the first spindle and to use the spindle orientation function (ORCMA<G070#6>, ORCMB<G074#6>) during polygon synchronization mode with two spindles. Basically, do not perform gear change, tool change, or workpiece change during the polygon synchronization mode. Have the PMC reject such commands and output a message prompting to release the two-spindle polygon synchronization mode, as required.

Signal address

	#7	#6	#5	#4	#3	#2	#1	#0
G038								*PLSST
	#7	#6	#5	#4	#3	#2	#1	#0
F063	PSYN					PSAR	PSE2	PSE1

Parameter

	#7	#6	#5	#4	#3	#2	#1	#0
7602			COF	HST	HSL	HDR	SNG	MNG

[Data type] Bit

MNG The rotational direction of the master axis (first spindle) in the spindle–spindle polygon turning mode is:

- 0: Not reversed.
- 1: Reversed.

SNG The rotational direction of the polygon synchronization axis (second spindle) in the spindle–spindle polygon turning mode is:

- 0: Not reversed.
- 1: Reversed.

HDR When phase control is exercised in spindle–spindle polygon turning mode (COF = 0), the phase shift direction is:

- 0: Not reversed for phase synchronization.
- 1: Reversed for phase synchronization.

NOTE

Use MNG, SNG, and HDR when the specified rotational direction of the master axis or polygon synchronization axis, or the specified phase shift direction is to be reversed in spindle–spindle polygon turning mode.

HSL When phase control is exercised in spindle–spindle polygon turning mode (COF = 0), this parameter selects the spindle that is subject to a phase shift operation for phase synchronization:

- 0: The polygon synchronization axis (second spindle) is selected.
- 1: The master axis (first spindle) is selected.

HST When phase control is applied in spindle–spindle polygon turning mode (COF = 0), and spindle–spindle polygon turning mode is specified:

- 0: Spindle–spindle polygon turning mode is entered with the current spindle speed maintained.
- 1: Spindle–spindle polygon turning mode is entered after the spindle is stopped.

NOTE

This parameter can be used, for example, when single–rotation signal detection cannot be guaranteed at an arbitrary feedrate because a separate detector is installed to detect the spindle single–rotation signal, as when a built–in spindle is used. (When bit 7 of parameter No. 4016 for the serial spindle is set to 1, together with this parameter, a single–rotation signal detection position in spindle–spindle polygon turning mode is guaranteed.)

COF In spindle–spindle polygon turning mode, phase control is:
 0: Used.
 1: Not used.

CAUTION
 When the use of phase control is not selected, the steady state is reached in a shorter time because phase synchronization control is not applied. Once steady rotation is achieved, however, polygonal turning must be completed without changing the steady state. (If the rotation is stopped, or the rotational speed altered, polygonal turning is disabled because of the inevitable phase shift.)
 Setting this parameter to 1 does not issue an alarm on the R command (phase command) in the same block as the G51.2. It is only ignored.

	#7	#6	#5	#4	#3	#2	#1	#0
7603	PST		RDG				QDR	RPL

[Data type] Bit

- RPL** Upon reset, spindle–spindle polygon turning mode is:
 0 : Released.
 1 : Not released.
- QDR** The rotational direction of the polygon synchronization axis:
 0 : Depends on the sign (+/–) of a specified value for Q.
 1 : Depends on the rotational direction of the first spindle. (If – is specified for Q, P/S alarm No. 218 is issued.)
- RDG** On the diagnosis screen No. 476, for spindle–spindle polygon phase command value (R), displays:
 0 : The specified value (in the increment system for the rotation axis).
 1 : The actual number of shift pulses.

NOTE
 A phase command is specified in address R, in units of degrees. For control, the actual shift amount is converted to a number of pulses according to the conversion formula:
 360 degrees = 4096 pulses. This parameter switches the display of a specified value to that of a converted value.

PST The polygon spindle stop signal *PLSST (bit 0 of G038) is:
 0 : Not used.
 1 : Used.

7621	Maximum allowable speed for the tool rotation axis (polygon synchronization axis)

[Data type] Word

[Unit of data] min^{-1}

[Valid data range] For polygon turning with two spindles:
Set a value between 0 and 32767, but which does not exceed the maximum allowable speed, as determined by the performance of the second spindle and other mechanical factors.

This parameter sets the maximum allowable speed of the tool rotation axis (polygon synchronization axis).

If the speed of the tool rotation axis (polygon synchronization axis) exceeds the specified maximum allowable speed during polygon turning, the speed is clamped at the maximum allowable speed. When the speed is clamped at a maximum allowable speed, however, synchronization between the spindle and tool rotation axis (polygon synchronization axis) is lost. And, when the speed is clamped, P/S alarm No. 5018 is issued.

7631	Allowable spindle speed deviation level in spindle–spindle polygon turning

[Data type] Byte

[Unit of data] min^{-1}

[Valid data range] 0 to 255

[Standard setting value] 1 to 10

This parameter sets the allowable level of deviation between the actual speed and specified speed of each spindle in spindle–spindle polygon turning. The value set with this parameter is used for both the master axis and polygon synchronization axis.

7632	Steady state confirmation time duration in spindle polygon turning

[Data type] Word

[Unit of data] ms

[Valid data range] 0 to 32767

This parameter sets the duration required to confirm that both spindles have reached their specified speeds in spindle–spindle polygon turning. If the state where the speed of each spindle is within the range set with parameter No. 7631, and has lasted at least for the duration specified with parameter No. 7632, the spindle polygon speed arrival signal PSAR <F0063#2> is set to 1.

7640	Master axis in spindle–spindle polygon turning
7641	Polygon synchronous axis in spindle–spindle polygon turning

[Data type] Byte

[Valid data range] 0, 1 to Number of spindles, or $m \times 10 + n$ (m:1 to Number of paths, n:1 to Number of spindles)

These parameters set the master and polygon synchronous (slave) axes in spindle–spindle polygon turning.

Settings 1 to 4: First to fourth serial spindles of the local path
 11 to 14: First to fourth serial spindles of path 1
 21 to 24: First to fourth serial spindles of path 2
 31 to 32: First to second serial spindles of path 3

NOTE

- 1 Spindle–spindle polygon turning option is enabled only for serial spindles.
- 2 When any one of parameter No. 7640 and No. 7641 is set to 0, polygon turning is performed using the first spindle (master axis) and the second spindle (polygon synchronous axis) in the path to which the parameter belongs.
- 3 To select a spindle of a different path (parameter setting = 11 and up, 21 and up, 32 and up), the system software B1F2 series (FS16i)/BEF2 series (FS18i) is required.
- 4 When one of the second to fourth serial spindles is used as a master axis, and the S command is to be used for the master axis, the multi–spindle control option is required.
- 5 When the PMC window function or G10 command is used to rewrite this parameter, rewrite this parameter before the block specifying the spindle–spindle polygon command G51.2 (G251). When the PMC window function is used to rewrite this parameter in the block immediately before G51.2 (G251), specify the rewriting of this parameter by using an M code (parameter No. 3411 and up) without buffering.

Alarm and message

Number	Message	Description
218	NOT FOUND P/Q COMMAND IN G251	<p>The G51.2 block does not contain P or Q, or a specified value is invalid.</p> <p>The causes of this alarm are detailed in DGN No. 471. (See below.)</p> <p>DGN No. 471#7 NPQ → When P and Q are not specified at all, R is specified. Alternatively, none of P, Q, and R has been specified.</p> <p>DGN No. 471#6 PQE → P or Q is out of the valid data range. Alternatively, P and Q are not specified as a pair.</p> <p>DGN No. 471#5 → A negative value is specified at Q when bit 1 (QDRC) of parameter No. 7603 = 1.</p> <p>DGN No. 471#4 NSP → There is no spindle necessary for control. (The spindle is not a serial spindle, or there is not the second spindle, etc.)</p>
219	COMMAND G250/G251 INDEPENDENTLY	G51.2/G251 and G50.1/G250 are specified together with other commands in the same block. Correct the program.
221	ILLEGAL COMMAND IN SYNCHRO	<p>An attempt was made to perform polygon synchronization operation together with Cs contouring control or balance cutting. Alternatively the program issued a command for spindle–spindle polygon synchronization mode, when the spindle is under spindle synchronization control, Cs contouring control, spindle positioning control, or rigid tapping control, etc.</p> <p>Correct the program.</p>
5018	POLYGON SPINDLE SPEED ERROR	<p>The specified rotation ratio cannot be maintained during the G51.2 mode, because the speed of the spindle or polygon synchronization axis exceeds the clamping value or is too low.</p> <p>The causes of this alarm are detailed in DGN No. 471. (See below.)</p> <p>DGN No. 471#3 SUO → The specified speed is too high.</p> <p>DGN No. 471#2 QCL → The polygon synchronization axis (second spindle) is clamped.</p> <p>DGN No. 471#1 PCL → The master axis (first spindle) is clamped.</p> <p>DGN No. 471#0 → The specified speed is too low.</p>

(Remarks)

- In a properly connected machine, P/S alarm No. 5018 does not basically occur for other than a reason that the polygon synchronization axis is clamped. (See descriptions of DGN for details.)

- To the contrary to P/S alarm No. 221, P/S alarm No. 194 occurs if another NC control spindle function is specified during the two-spindle polygon synchronization mode.

Caution

CAUTION

- 1 The maximum spindle speed for each gear stage (No. 3741 to 3744) must be specified correctly according to the model of the machine. In addition, ordinary spindle connections must have been terminated.
- 2 This function uses the one-rotation signal for the spindle as a reference point for phase adjustment.
When a built-in sensor is used, and there are gears between the spindle and spindle motor, it is necessary to install a detector on the spindle separately to take a one-rotation signal from the spindle. If the detector does not guarantee detection of a correct position from arbitrary speed, set bit 4 (PHST) of parameter No. 7602 and bit 7 of serial spindle parameter No. 4016 to 1. This setting reduces the spindle speed automatically down to 0 for spindle position detection each time the spindle-spindle polygonal turning mode is entered, thus guaranteeing a correct phase relationship during spindle-spindle polygon synchronization mode.
- 3 This function uses the spindle synchronization function for serial spindles. (However, it does not require the spindle synchronization option for the CNC.) You may need to specify the relevant serial spindle parameters (such as Nos. 4032 to 4035).
Specify the same serial spindle loop gain for both spindles. If the same serial spindle loop gain is not used for both spindles, polygonal turning may not be accurate.
If an attempt is made to perform spindle-spindle polygonal turning, DGN 470#6 LGE becomes 1. (No alarm is issued.)
- 4 Before using the polygon synchronization mode, place both first and second spindles in the spindle control mode. The polygon synchronization mode cannot be used if they are already in other modes (Cs contouring control mode or spindle orientation mode, etc.).
- 5 During the polygon synchronization mode, the speed of the second spindle cannot be controlled independently of the speed of the first spindle.
During the polygon synchronization mode, the spindle orientation function (ORCMA<G070#6>, ORCMB<G074#6>) cannot be used for either the first spindle or second spindle. Therefore, gear, tool or workpiece change is basically unusable during the polygon synchronization mode.

CAUTION

- 6 During polygon synchronization mode, speed change and phase adjustment are performed each time the spindle speed is changed. Therefore, this mode cannot be used together with a function that causes continuous spindle speed change (such as G96 constant surface speed control)
- 7 During the polygon synchronization mode, the rotation ratio between the master axis and polygon synchronization axis is controlled with priority. Therefore, the difference between the master axis speed and S command value may become larger than during ordinary spindle control. (The master axis speed may be up to 2 min^{-1} lower than specified.)

Note**NOTE**

- 1 During the polygon synchronization mode, phase control is performed in the least command increment of $36/4096 = 0.08789\dots$ (degrees) in reference to the one-rotation signal for each spindle. Actually, a command value out of a range from 0 to 359.999... is meaningless because the relative phase is controlled within one rotation of each spindle. However, this function does not limit the R command value and the CNC converts the R command value to a value below 360 degrees.
- 2 The G51.2 command during conversational function is equivalent to the G50.2 command. (The system does not enter the polygon synchronization mode. If it is already in the polygon synchronization mode, release it using a G51.2 command.)

Reference item

Series 16i/18i/160i/180i/ 160is/180is	OPERATOR'S MANUAL (For Lathe) (B-63524EN)	II.19.1	POLYGONAL TURNING
Series 21i/210i/210is	OPERATOR'S MANUAL (For Lathe) (B-63604EN)	II.19.1	POLYGONAL TURNING

6.12 NORMAL DIRECTION CONTROL (M SERIES)

General

When a tool with a rotation axis (C-axis) is moved in the XY plane during cutting, the normal direction control function can control the tool so that the C-axis is always perpendicular to the tool path (Fig. 6.12).

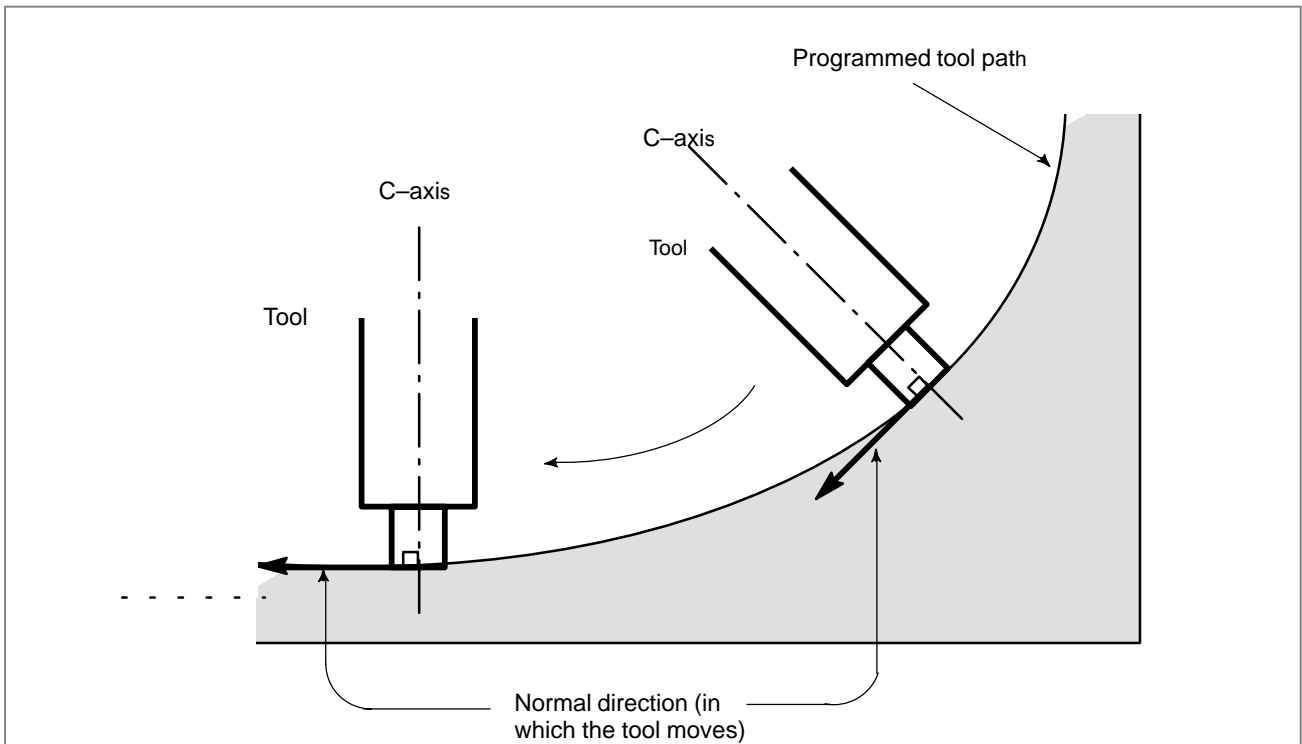

Fig. 6.12 Sample Movement of the tool

Movement of the tool inserted at the beginning of each block is executed at the feedrate set in parameter 5481. If dry run mode is on at that time, the dry run feedrate is applied. If the tool is to be moved along the X- and Y-axes in rapid traverse (G00) mode, the rapid traverse rate is applied.

If the feedrate of the C axis exceeds the maximum cutting feedrate of the C axis specified to parameter No. 1422, the feedrate of each of the other axes is clamped to keep the feedrate of the C axis below the maximum cutting feedrate of the C axis.

Parameter

	#7	#6	#5	#4	#3	#2	#1	#0
1006							ROSx	ROTx

NOTE

When this parameter is changed, turn off the power before continuing operation.

[Data type] Bit axis

[Valid data range] ROTx, ROSx Setting linear or rotation axis

ROSx	ROTx	Description
0	0	Linear axis <ul style="list-style-type: none"> · Inch/metric conversion is done. · All coordinate values are linear axis type. (Not rounded in 0 to 360°) · Stored pitch error compensation is linear axis type (Refer to parameter No. 3624)
0	1	Rotation axis (A type) <ul style="list-style-type: none"> · Inch/metric conversion is not done. · Machine coordinate values are rounded in 0 to 360° Rounding of absolute coordinate values and relative coordinate values is decided by parameter No. 1008#0 and #2. · Stored pitch error compensation is of the rotation type. (Refer to parameter No. 3624) · Automatic reference position return (G28, G30) is done in the reference position return direction and the move amount does not exceed one rotation.
1	0	Setting is invalid (unused)
1	1	Rotation axis (B type) <ul style="list-style-type: none"> · Inch/metric conversion is not done. · Machine coordinate values is of linear axis type (i.e. not rounded in 0 to 360°). · Rounding of absolute coordinate values and relative coordinate values is decided by parameter No. 1008#0 and #2. · Stored pitch error compensation is of linear axis type (Refer to parameter No. 3624). · Cannot be used with the rotation axes roll over function and the index table indexing function (M series).

NOTE

The rotation axis must be set to the normal direction control axis.

5480

Number of the axis for controlling the normal direction

[Data type] Byte

[Valid data range] 1 to the maximum control axis number

This parameter sets the control axis number of the axis which controls the normal direction.

5481

Rotation feedrate of normal direction control axis

[Data type] Word

[Unit of data] 1 deg/min

[Valid data range] 1 to 15000

This parameter sets the feedrate of a normal direction control axis that is inserted at the start point of a block during normal direction control.

5482 Limit value that ignores the rotation insertion of normal direction control axis

[Data type] Two-word

[Unit of data]	Increment system	IS-A	IS-B	IS-C	Unit
	Rotation axis	0.01	0.001	0.0001	deg

[Valid data range] 1 to 99999999

The rotation block of a normal direction control axis is not inserted when the rotation insertion angle calculated during normal direction control does not exceed this setting value. The ignored rotation angle is added to the next rotation insertion angle. The block insertion is then judged.

NOTE

- 1 No rotation block is inserted when 360 or more degrees are set.
- 2 If 180 or more degrees are set, a rotation block is inserted only when the circular interpolation is 180 or more degrees.

5483 Limit value of movement that is executed at the normal direction angle of a preceding block

[Data type] Two-word

[Unit of data]	Increment system	IS-A	IS-B	IS-C	Unit
	Metric input	0.01	0.001	0.0001	mm
	Inch input	0.001	0.0001	0.00001	inch

[Valid data range] 1 to 99999999

This parameter sets the limit value of movement at the normal direction angle of a preceding block.

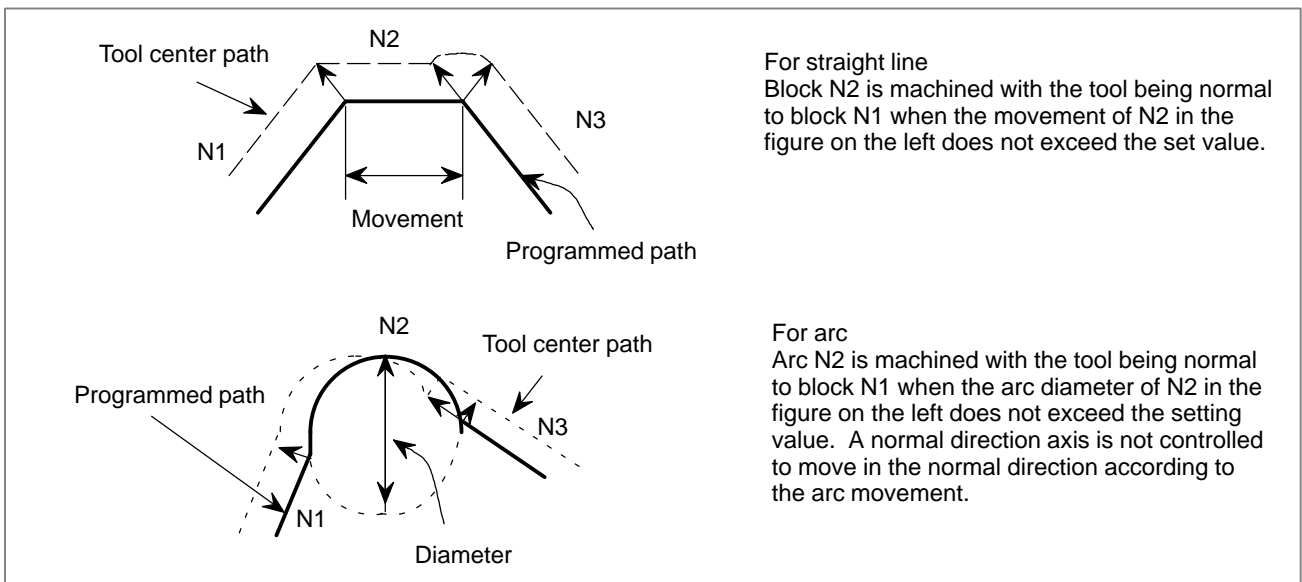

	#7	#6	#5	#4	#3	#2	#1	#0
5484						ANM	CTI	SDC

[Data type] Bit

SDC In normal direction control:

- 0 : A C-axis movement is automatically inserted between blocks so that the C-axis is directed at right angles to the direction of motion at the start point of each block. (After movement on the C-axis, movement (along the X-axis and Y-axis) specified by the block is performed.)
- 1 : If the amount of C-axis movement is smaller than the value set in parameter No.5485, a C-axis movement is not inserted before a block. Instead, it is performed together with movement along the X-axis and Y-axis.

CTI If such an arc that the vector from the center of the arc to a start point rotates in the reverse direction after cutter compensation is specified during normal direction control in the cutter compensation C mode:

- 0 : P/S 041 alarm is issued.
- 1 : The command is executed.

If this parameter is set to 1, and such an arc that the vector from the center of the arc to a start point rotates in the reverse direction after cutter compensation is specified during normal direction control in the cutter compensation C mode (see the tool path from (4) to (5) in the figure below), the tool is controlled so that the tool faces in the direction at right angles to the move direction (programmed path) before cutter compensation (see the tool path from (2) to (3) in the figure below).

Thus, as shown by the programmed path from (4) to (5) in the figure below, the inside of an arc where the radius of the workpiece is smaller than the compensation value of the tool can be cut.

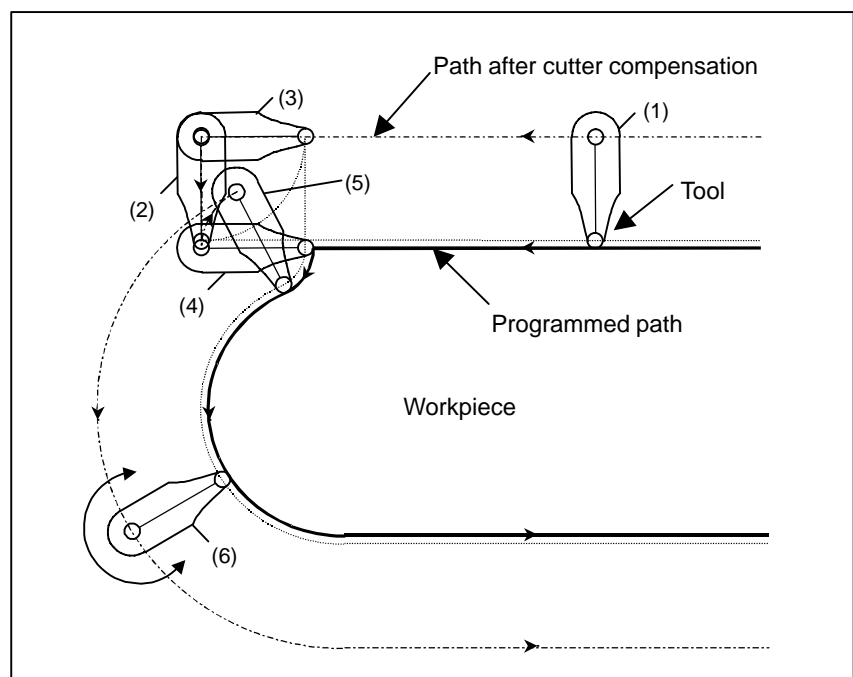

NOTE

When this parameter is set to 1, no interference check is made in cutter compensation C.

ANM In AI contour control mode, the normal direction control function is:
 0 : Disabled.
 1 : Enabled.

5485

Limit imposed on the insertion of a single block for rotation about the normal direction control axis

[Data type] 2-word

[Unit of data]	Increment system	IS-A	IS-B	IS-C	Units
	Rotation axis	0.01	0.001	0.0001	deg

[Valid data range] 1 to 99999999

When normal direction control is applied, the amount of movement (rotation angle) on the normal direction control axis (C-axis), calculated so that the C-axis is directed at right angles to the direction of motion at the start point of a block, may be smaller than the value specified in this parameter. In such a case, the C-axis movement is not inserted before the movement (along the X-axis and Y-axis) specified by the block. Instead, the C-axis movement is performed together with the movement specified by the block. If the amount of movement (rotation angle) on the C-axis is greater than or equal to the value specified with this parameter, the C-axis movement is inserted, and the movement specified by the block is made after the completion of the C-axis movement.

NOTE

This parameter is enabled when the SDC parameter (bit 0 of parameter No.5484) is set to 1. If a value equal to or greater than 180 degrees is specified, a C-axis movement is inserted only when circular interpolation involving a C-axis rotation of 180 degrees or more is performed.

1422

Maximum cutting feedrate for all axes

[Data type] Two-word**[Unit of data]****[Valid data range]**

Increment system	Unit of data	Valid data range	
		IS-A, IS-B	IS-C
Millimeter machine	1 mm/min	6 – 240000	6 – 100000
Inch machine	0.1 inch/min	6 – 96000	6 – 48000

Specify the maximum cutting feedrate.

A feedrate in the tangential direction is clamped in cutting feed so that it does not exceed the feedrate specified in this parameter.

NOTE

To specify the maximum cutting feedrate for each axis, use parameter No. 1430 instead.

Note**NOTE**

The helical interpolation option is required to use this function.

Reference item

Series 16i/18i/160i/180i/ 160is/180is	OPERATOR'S MANUAL (For Machining Center) (B-63534EN)	II.14.11	Normal Direction Control
Series 21i/210i/210is	OPERATOR'S MANUAL (For Machining Center) (B-63614EN)	II.14.9	Normal Direction Control

6.13 EXPONENTIAL INTERPOLATION (M SERIES)

General

Exponential interpolation exponentially changes the rotation of a workpiece with respect to movement on the rotary axis. Furthermore, exponential interpolation performs linear interpolation with respect to another axis. This allows tapered groove machining with a constant helix angle (constant helix taper machining). This function is best suited for grooving and grinding tools such as end mills.

Parameter

	#7	#6	#5	#4	#3	#2	#1	#0
5630								
								SPN

[Data type] Bit

SPN The amount of linear axis division (span value) in exponential interpolation is:

0 : Specified with parameter No. 5643.

1 : Specified using address K in a block containing G02.3/G03.3. When address K is not specified, the value set with parameter No. 5643 is used.

5641	
	Linear axis number subject to exponential interpolation

[Data type] Byte

[Valid data range] 1 to number of controlled axes

This parameter sets the ordinal number, among the controlled axes, for the linear axis to which exponential interpolation is applied.

5642	
	Rotation axis number subject exponential interpolation

[Data type] Byte

[Valid data range] 1 to number of controlled axes

This parameter sets the ordinal number, among the controlled axes, for the rotation axis to which exponential interpolation is applied.

5643	Amount of linear axis division (span value) in exponential interpolation
------	--

[Data type] 2-word

[Valid data range]	Increment system	IS-A	IS-B	IS-C	Unit
	Metric input	0.01	0.001	0.0001	mm
	Inch input	0.001	0.0001	0.00001	inch

[Valid data range] 1 to 99999999

This parameter sets the amount of linear axis division in exponential interpolation when bit 0 (SPN) of parameter No. 5630 is set to 0.

Alarm and message

No.	Message	Contents
5060	ILLEGAL PARAMETER IN G02.3/G03.3	Parameter setting is illegal. No. 5641 (setting of the linear axis) is not specified. No. 5641 specifies an axis other than a linear axis. No. 5642 (setting of the rotation axis) is not specified. No. 5642 specifies an axis other than a rotation axis. The CNC cannot control the linear or rotation axis (the value of No. 1010 is exceeded).
5061	ILLEGAL FORMAT IN G02.3/G03.3	The command for exponential interpolation (G02.3/G03.3) contains a format error. Address I, J, or R is not specified. Addresses I, J, and R are out of range.
5062	ILLEGAL COMMAND IN G02.3/G03.3	The command for exponential interpolation (G02.3/G03.3) contains an illegal value. The specified value is not suitable for exponential interpolation (for example, a negative value is subject to In).

Reference item

Series 16i/18i/160i/180i/ 160is/180is	OPERATOR'S MANUAL (For Machining Center) (B-63534EN)	II.4.11	Exponential interpolation
---	--	---------	---------------------------

6.14 SMOOTH INTERPOLATION (M SERIES)

General

Either of two types of machining can be selected, depending on the program command.

- For those portions where the accuracy of the figure is critical, such as at corners, machining is performed exactly as specified by the program command.
- For those portions having a large radius of curvature where a smooth figure must be created, points along the machining path are interpolated with a smooth curve, and calculated from the polygonal lines specified with the program command (smooth interpolation).

Smooth interpolation can be specified when CDS (bit 5 of parameter No. 8485) is set to 1 in high-speed contour control mode (between G05 P10000 and G05 P0). Smooth interpolation performed in high-speed contour control mode is described below. For details of high-speed contour control, see subsec 7.1.14.

Parameter

	#7	#6	#5	#4	#3	#2	#1	#0
8485			CDS					

[Data type] Bit

CDS 0 : Disables smooth interpolation in HPCC mode.
1 : Enables smooth interpolation in HPCC mode.

To apply smooth interpolation, be sure to set this parameter to 1.

8486	Maximum travel distance of a block where smooth interpolation is applied
------	--

[Data type] Two-word

[Unit of data] Least input increment (depending on the set reference axis)

[Valid data range] 0 to 99999999

This parameter specifies a block length used as a reference to decide whether to apply smooth interpolation. If the line specified in a block is longer than the value set in the parameter, smooth interpolation will not be applied to that block. This parameter can be used, for example, to specify the maximum line length of a folded line to which a metal die workpiece is approximated with some tolerance.

Alarm and message

Number	Message	Description
5085	SMOOTH IPL ERROR 1	A block for specifying smooth interpolation contains a syntax error.

Reference item

Series 16i/18i/160i/180i/ 160is/180is	OPERATOR'S MANUAL (For Machining Center) (B-63534EN)	II.4.12	Smooth interpolation
---	--	---------	----------------------

6.15 HYPOTHETICAL AXIS INTERPOLATION

General

In helical interpolation, when pulses are distributed with one of the circular interpolation axes set to a hypothetical axis, sine interpolation is enable.

When one of the circular interpolation axes is set to a hypothetical axis, pulse distribution causes the speed of movement along the remaining axis to change sinusoidally. If the major axis for threading (the axis along which the machine travels the longest distance) is set to a hypothetical axis, threading with a fractional lead is enabled. The axis to be set as the hypothetical axis is specified with G07.

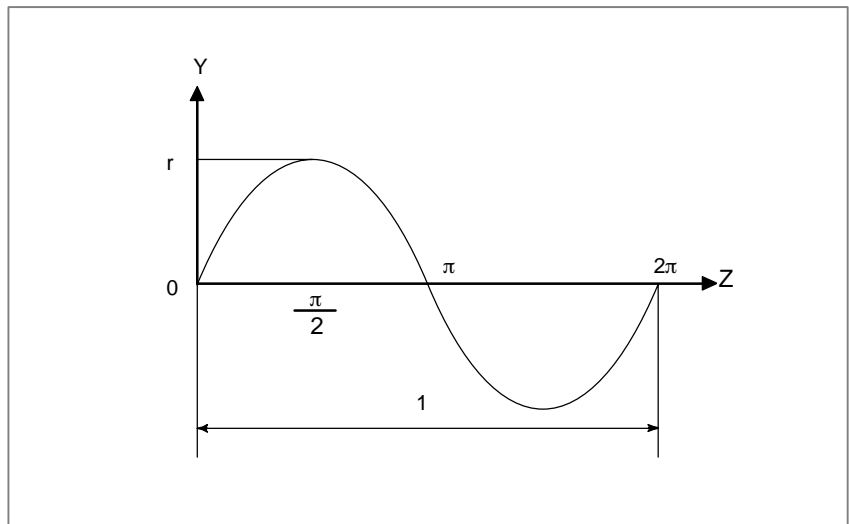

Reference item

Series 16i/18i/160i/180i/ 160is/180is	OPERATOR'S MANUAL (For Machining Center) (B-63534EN)	II.4.14	Hypothetical axis interpolation
	OPERATOR'S MANUAL (For Lathe) (B-63524EN)	II.4.8	Hypothetical axis interpolation

6.16 HELICAL INTERPOLATION B (M SERIES)

General

Helical interpolation B moves the tool helically. This interpolation can be executed by specifying the circular interpolation command together with up to four additional axes in AI contour control mode.

Basically, the command can be specified by adding two movement axes to a standard helical interpolation command. Address F should be followed by a tangential velocity, determined by also taking movement along the linear axes into consideration.

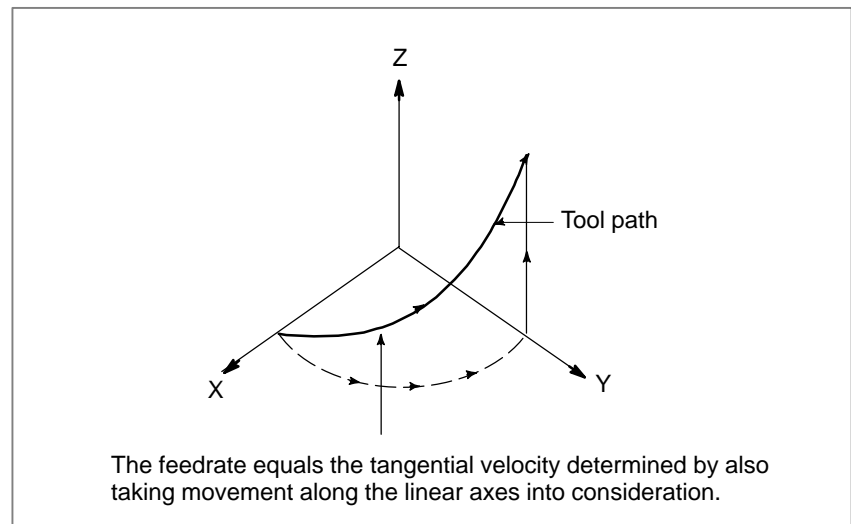

Reference item

Series 16i/18i/160i/180i/ 160is/180is	OPERATOR'S MANUAL (For Machining Center) (B-63534EN)	II.4.6	Helical interpolation B
---	--	--------	-------------------------

6.17 SPIRAL INTERPOLATION, CONICAL INTERPOLATION (M SERIES)

General

Spiral interpolation is enabled by specifying the circular interpolation command together with a desired number of revolutions or a desired increment (decrement) for the radius per revolution.

Conical interpolation is enabled by specifying the spiral interpolation command together with one or two additional axes of movement, as well as a desired increment (decrement) for the position along the additional axes per spiral revolution.

Spiral interpolation and conical interpolation do not support bell-shaped acceleration/deceleration after interpolation for cutting feed.

• Spiral interpolation

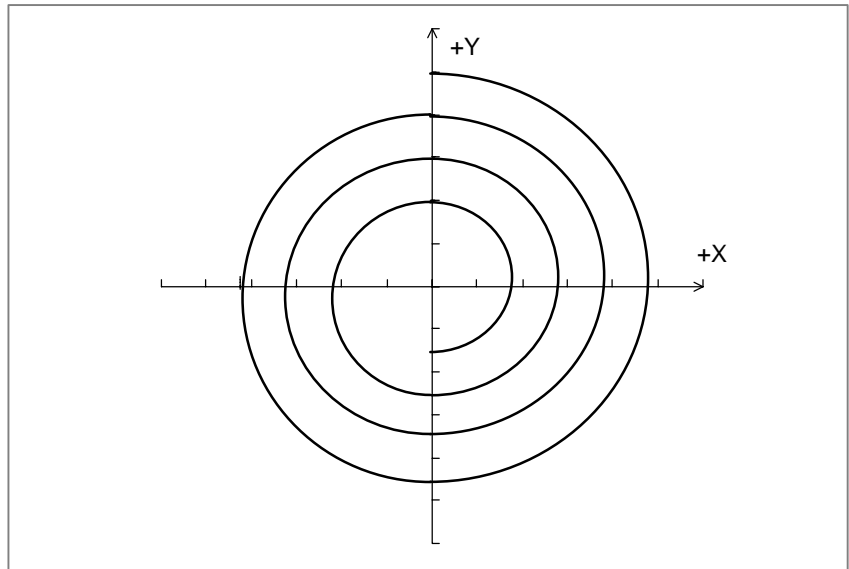

• Conical interpolation

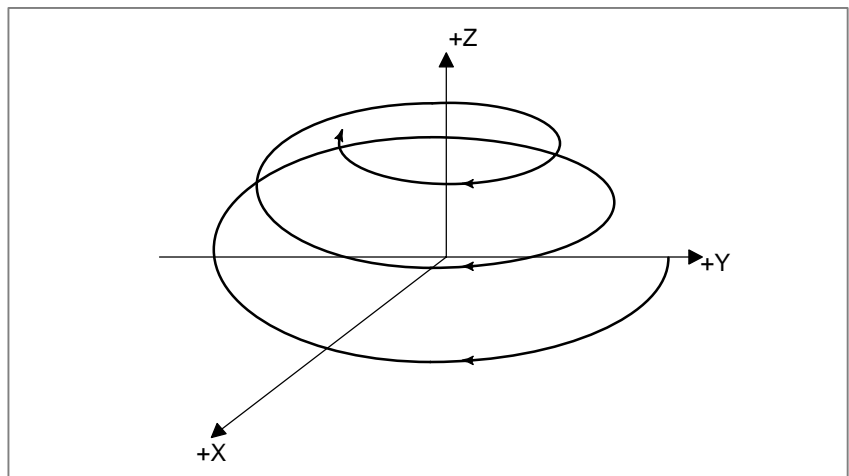

Parameter

3471

Allowable difference between the specified end point and that calculated from the increment (or decrement) and number of revolutions for spiral or conical interpolation

[Data type] Two-word

[Unit of data]	Increment system	IS-A	IS-B	IS-C	Unit
	Metric input	0.01	0.001	0.0001	mm
	Inch input	0.001	0.0001	0.00001	inch

[Valid data range] 0 to 99999999

This parameter sets the maximum allowable value for the difference (absolute value) between the specified end point and that calculated from the increment (or decrement) and number of revolutions for spiral or conical interpolation.

3472

Minimum radius with which the actual feedrate is maintained for spiral or conical interpolation

[Data type] Two-word

[Unit of data]	Increment system	IS-A	IS-B	IS-C	Unit
	Metric input	0.01	0.001	0.0001	mm
	Inch input	0.001	0.0001	0.00001	inch

[Valid data range] 1000 to 99999999 (metric input)
10000 to 99999999 (inch input)

If this parameter is set to 0 or a value that falls outside the valid data range, the minimum value in the valid data range is assumed.

Spiral and conical interpolation usually maintain a constant feedrate. Near the center of the spiral, however, the radius is very small, such that applying a constant feedrate would cause the angular velocity to become very high. To prevent this, the angular velocity is regulated to a constant value once the radius of the spiral has decreased to the value specified with the parameter. As a result, the actual feedrate decreases.

Alarm and message

Number	Message	Description
5122	ILLEGAL COMMAND IN SPIRAL	An invalid command has been specified for spiral or conical interpolation. The most likely causes are as follows: 1) L = 0 specified 2) Q = 0 specified 3) R/, R/, C specified 4) Height increment of 0 specified 5) More than three height axes specified 6) Height increment specified together with two height axes 7) Conical interpolation specified when the helical interpolation option is not being used 8) Q < 0 specified when the radius difference > 0 9) Q > 0 specified when the radius difference < 0 10) Height increment specified without specifying a height axis
5123	OVER TOLERANCE OF END POINT	The difference between the specified end point and calculated end point exceeds the allowable range (parameter No. 3471).
5124	CAN NOT COMMAND SPIRAL	Spiral or conical interpolation has been specified in any of the following modes: 1) Scaling 2) Programmable mirror image 3) Polar coordinate interpolation Alternatively, in cutter compensation mode C, the center coincides with the start or end point.

Reference item

Series 16i/18i/160i/180i/ 160is/180is	OPERATOR'S MANUAL (For Machining Center) (B-63534EN)	II.4.7	Spiral interpolation, conical interpolation
---	--	--------	---

6.18 NURBS INTERPOLATION (M SERIES)

General

Many computer-aided design (CAD) systems used to design metal dies for automobiles and airplanes utilize non-uniform rational B-spline (NURBS) to express a sculptured surface or curve for the metal dies.

This function allows NURBS curve expression to be directly specified to the CNC. This eliminates the need for approximating the NURBS curve with small line segments. This offers the following advantages:

1. Elimination of approximation error caused by small line segments
2. Short part program
3. No break between blocks when small blocks are executed at high speed
4. No need for high-speed transfer from the host computer to the CNC

When this function is used, a computer-aided machining (CAM) system creates a NURBS curve according to the NURBS expression output from the CAD system, after compensating for the length of the tool holder, tool diameter, and other tool elements. The NURBS curve is programmed in the NC format by using these three defining parameters: control point, weight, and knot.

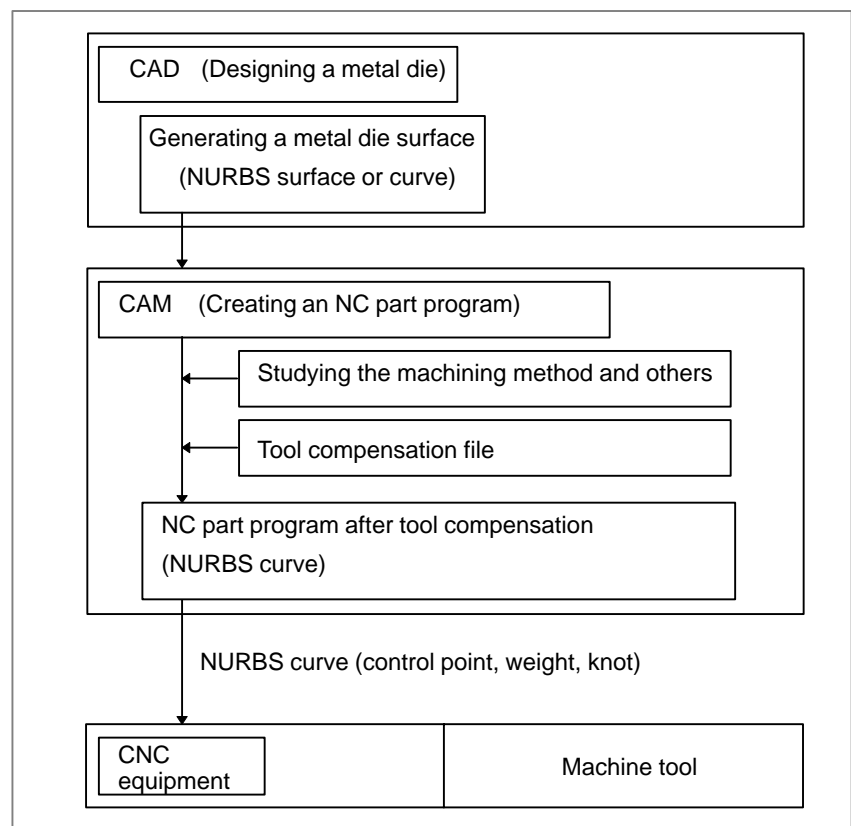

Fig. 6.18 NC part program for machining a metal die according to a NURBS curve

NURBS interpolation must be specified in high-precision contour control mode (between G05 P10000 and G05 P0). The CNC executes NURBS interpolation while smoothly accelerating or decelerating the movement so that the acceleration on each axis will not exceed the allowable maximum acceleration of the machine. In this way, the CNC automatically controls the speed in order to prevent excessive strain imposed on the machine.

Parameter

For parameter information, see Subsection 7.1.14, "High-precision Contour Control by RISC (M series)".

Alarm and message

Number	Message	Description
5115	SPL: ERROR	An illegal rank is specified.
		No knot is specified.
		An illegal knot is specified.
		Too many axes are specified.
		Other program error
5116	SPL: ERROR	A look-ahead block contains a program error.
		The knot does not increase at a constant rate.
		An inhibited mode is specified in NURBS interpolation mode.
5117	SPL: ERROR	The first NURBS control point is illegal.
5188	SPL: ERROR	An attempt was made to resume NURBS interpolation after manual intervention in manual absolute mode.

Reference item

Series 16i/18i/160i/180i/ 160is/180is	OPERATOR'S MANUAL (For Machining Center) (B-63534EN)	II.4.13	NURBS interpolation
---	--	---------	---------------------

6.19 LINEAR INTERPOLATION (G28, G30, G53)

General

When positioning operation of linear interpolation type is specified (bit 1 (LRP) of parameter No. 1401 = 1), the following operations can also be set as operations of linear interpolation type by setting bit 4 (ZLN) of parameter No. 1015 to 1:

- Movement from an intermediate point to a reference position in automatic reference position return operation (G28)
- Movement from an intermediate point to a reference position in second, third, or fourth reference position return operation (G30)
- Positioning by machine coordinate system selection (G53)

When any of the operations above is set as an operation of linear interpolation type, acceleration/deceleration control follows the setting of bit 4 (RCT) of parameter No. 1603.

Parameter

	#7	#6	#5	#4	#3	#2	#1	#0
1015				ZLN				

[Data type] Bit

ZLN When positioning of linear interpolation type is specified (bit 1 (LRP) of parameter No. 1401 = 1), automatic reference position return operation (G28), second to fourth reference position return operation, and machine coordinate system selection are set as:

- 0 : Positioning of non-linear interpolation type.
- 1 : Positioning of linear interpolation type.

This parameter is valid when bit 1 (LRP) of parameter No. 1401 = 1.

	#7	#6	#5	#4	#3	#2	#1	#0
1603				RCT				

[Data type] Bit

RCT When positioning of linear interpolation type is specified (bit 1 (LRP) of parameter No. 1401 = 1), acceleration/deceleration control is based on:

- 0 : Constant acceleration/deceleration method.
- 1 : Constant time (time constant) method.

Note**1 Manual intervention**

Positioning of non-linear interpolation type is performed if the automatic operation stop state is set by feed hold or mode switching during movement then the subsequent operation of the program is performed after the machine is moved by manual operation.

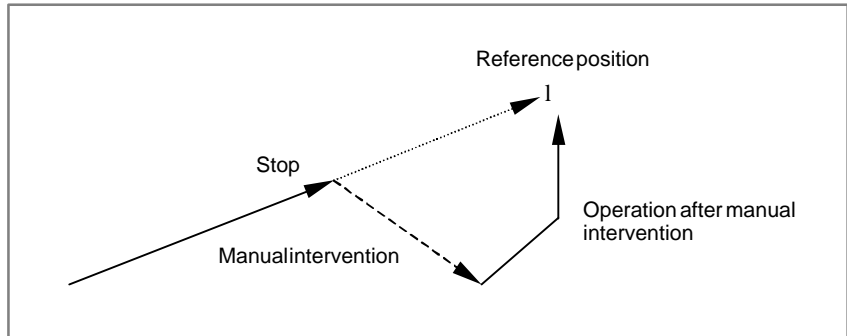

Fig. 6.19 Operation after manual intervention

If the machine position remains unchanged before and after manual intervention (if the machine is not moved in the automatic operation stop state or the machine is returned to the position before manual intervention), positioning of linear interpolation type is performed in the subsequent operation of the program.

2 Automatic reference position return operation of low-speed type (G28)

If reference position return operation is not performed for a specified axis even once after the power is turned on in automatic reference position return operation (G28), a reference position return operation of low-speed type is performed for the axis.

At this time, positioning of non-linear interpolation type is performed. For example, if G28X0Y0Z0; is specified when reference position return operation is completed for the X-axis and Y-axis, and is not completed for the Z-axis, positioning of non-linear interpolation type is performed.

6.20 THREE- DIMENSIONAL CIRCULAR INTERPOLATION (M SERIES)

General

By specifying an intermediate point and end point for an arc, circular interpolation can be performed in three-dimensional space.

As shown below, three points, namely, a start point (current position), a specified intermediate point, and a specified end point uniquely define an arc in three-dimensional space. Two blocks are used for specification. One block specifies up to an intermediate point, and the other block specifies up to an end point.

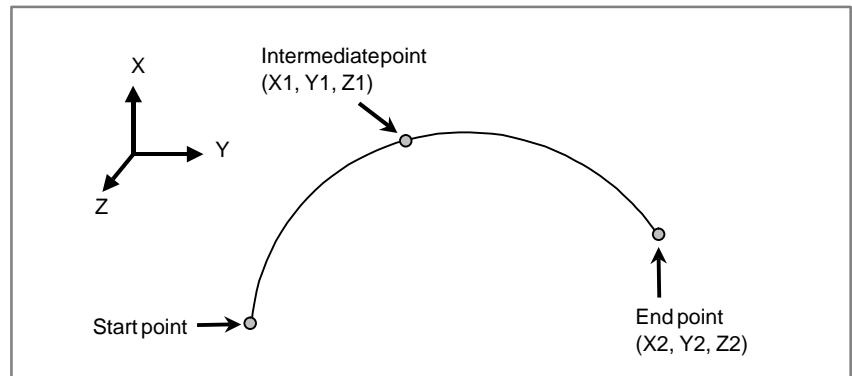

Fig. 6.20 Start point, intermediate point, and end point

RISC processor is necessary, if this function is used. Refer to Subsection 7.1.19 “RISC Processor Operation,” in this manual too.

Parameter

	#7	#6	#5	#4	#3	#2	#1	#0
1401						HTG		

[Input type] Parameter input

[Data type] Bit

HTG For helical interpolation/three-dimensional interpolation:

0 : The tangential feedrate of an arc/three-dimensional arc is used.

1 : The tangential feedrate involving a linear axis (specified axes other than a circular interpolation axis in the case of three-dimensional circular interpolation) is specified.

Alarm and message

Number	Message	Description
5430	ILLEGAL COMMAND IN 3-D	In modal state where three-dimensional circular interpolation must not be specified, three-dimensional circular interpolation (G02.4/G03.4) was specified. A code that must not be specified in the three-dimensional circular interpolation mode was specified.
5432	G02.4/G03.4 FORMAT ERROR	The three-dimensional circular interpolation command (G02.4/G03.4) contains an error.
5433	MANUAL INTERVENTION IN 2-D CIR	In the three-dimensional circular interpolation mode (G02.4/G03.4), manual intervention was performed when the manual absolute switch is on.

Reference item

Connection manual (This function)	7.1.19	RISC Processor Operation
--------------------------------------	--------	--------------------------

7 FEEDRATE CONTROL/ACCELERATION AND DECELERATION CONTROL



7.1 FEEDRATE CONTROL

The feed functions control the feedrate of the tool. The following two feed functions are available:

1. Rapid traverse
When the positioning command (G00) is specified, the tool moves at a rapid traverse rate set in the CNC (parameter No. 1420).
2. Cutting feed
The tool moves at a programmed cutting feedrate.

Override can be applied to a rapid traverse rate or cutting feedrate using the override signal.

7.1.1 Rapid Traverse Rate

General

The positioning command (G00) positions the tool by rapid traverse.

G00 IP_ ;

**G00 : G code (group 01) for positioning (rapid traverse)
IP_ ; Dimension word for the end point**

In rapid traverse, the next block is executed after the specified rate becomes 0 and the servo motor reaches a certain range set by the parameter (No.1826) (in-position check).

A rapid traverse rate is set for each axis by parameter No. 1420, so no rapid traverse rate need be programmed.

The following overrides can be applied to a rapid traverse rate with the rapid traverse override signal:F0, 25, 50, 100%

F0: Allows a fixed feedrate to be set for each axis by parameter No. 1421. In addition, the use of the 1% rapid traverse override selection signal allows a rapid traverse override of between 0% and 100% to be applied in 1% steps.

Signal

Rapid traversing signal RPDO <F002#1>

[Function] This signal indicates that a move command is executed at rapid traverse.

[Output condition] “1” indicates that an axis starts moving after rapid traverse has been selected.

“0” indicates that an axis starts moving after a feedrate other than rapid traverse has been selected. This holds true for both automatic and manual operation modes.

NOTE

- 1 The rapid traverse in automatic operation includes all rapid traverses in canned cycle positioning, automatic reference point return, etc., as well as the move command G00. The manual rapid traverse also includes the rapid traverse in reference position return.
- 2 Once rapid traverse has been selected, this signal remains "1", including during a stop, until another feedrate has been selected and movement is started.

Signal address

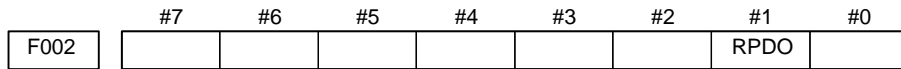

Parameter

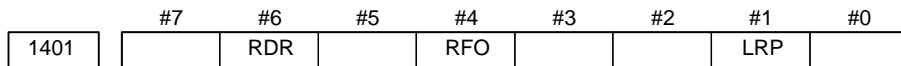

[Data type] Bit

LRP Positioning (G00)

- 0 : Positioning is performed with non-linear type positioning so that the tool moves along each axis independently at rapid traverse.
- 1 : Positioning is performed with linear interpolation so that the tool moves in a straight line.

RFO When cutting feedrate override is 0% during rapid traverse

- 0 : The machine tool does not stop moving.
- 1 : The machine tool stops moving.

RDR Dry run for rapid traverse command

- 0 : Disabled
- 1 : Enabled

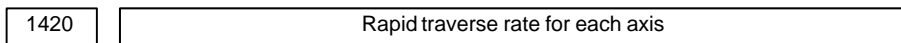

[Data type] Two-word axis

[Unit of data]

[Valid data range]

Increment system	Unit of data	Valid data range	
		IS-A, IS-B	IS-C
Millimeter machine	1 mm/min	30 - 240000	30 - 100000
Inch machine	0.1 inch/min	30 - 96000	30 - 48000
Rotation axis	1 deg/min	30 - 240000	30 - 100000

Set the rapid traverse rate when the rapid traverse override is 100% for each axis.

1424	Manual rapid traverse rate for each axis
------	--

[Data type] Two-word axis

[Unit of data]

[Valid data range]

Increment system	Unit of data	Valid data range	
		IS-A, IS-B	IS-C
Millimeter machine	1 mm/min	30 – 240000	30 – 100000
Inch machine	0.1 inch/min	30 – 96000	30 – 48000
Rotation axis	1 deg/min	30 – 240000	30 – 100000

Set the rate of manual rapid traverse for each axis when the rapid traverse override is 100% for each axis.

NOTE

If 0 is set, the rate set in parameter 1420 is assumed.

Reference item

Series 16i/18i/160i/180i/ 160is/180is	OPERATOR'S MANUAL (For Machining Center) (B-63534EN)	II.5.2	Rapid traverse
	OPERATOR'S MANUAL (For Lathe) (B-63524EN)	II.5.2	Rapid traverse
Series 21i/210i/210is	OPERATOR'S MANUAL (For Machining Center) (B-63614EN)	II.5.2	Rapid traverse
	OPERATOR'S MANUAL (For Lathe) (B-63604EN)	II.5.2	Rapid traverse
Series 20i	OPERATOR'S MANUAL (For Manual Milling Machine) (B-64204EN)	II.5.2	Rapid traverse
	OPERATOR'S MANUAL (For Manual Lathes) (B-64194EN)	II.5.2	Rapid traverse

7.1.2 Cutting Feedrate Clamp

General

A common upper limit can be set on the cutting feedrate along each axis with parameter No. 1422. If an actual cutting feedrate (with an override applied) exceeds a specified upper limit, it is clamped to the upper limit. For M series, the upper limit can be set on the cutting feedrate for each axis with parameter No. 1430.

Parameter

1422	Maximum cutting feedrate for all axes
------	---------------------------------------

[Data type] Two-word

[Unit of data] [Valid data range]	Increment system	Unit of data	Valid data range	
			IS-A, IS-B	IS-C
	Millimeter machine	1 mm/min	6 – 240000	6 – 100000
	Inch machine	0.1 inch/min	6 – 96000	6 – 48000

Specify the maximum cutting feedrate.

A feedrate in the tangential direction is clamped in cutting feed so that it does not exceed the feedrate specified in this parameter.

NOTE
To specify the maximum cutting feedrate for each axis, use parameter No. 1430 instead. (M series)

1430	Maximum cutting feedrate for each axis
------	--

[Data type] Two-word axis

[Unit of data] [Valid data range]	Increment system	Unit of data	Valid data range	
			IS-A, IS-B	IS-C
	Millimeter machine	1 mm/min	6 – 240000	6 – 100000
	Inch machine	0.1 inch/min	6 – 96000	6 – 48000
	Rotation axis	1 deg/min	6 – 240000	6 – 100000

Specify the maximum cutting feedrate for each axis.

A feedrate for each axis is clamped in cutting feed so that it does not exceed the maximum feedrate specified for each axis.

NOTE

- 1 This parameter is effective only in linear and circular interpolation. In polar coordinate, cylindrical, and involute interpolation, the maximum feedrate for all axes specified in parameter No. 1422 is effective.
- 2 If the setting for each axis is 0, the maximum feedrate specified in parameter No. 1422 is applied to all axes and the feedrate is clamped at the maximum feedrate.

Alarm and message

Number	Message	Description
5009	PARAMETER ZERO (DRY RUN)	The maximum feedrate (parameter No. 1422) or the feedrate in dry run (parameter No. 1410) is set to 0 in the HPCC model.
5011	PARAMETER ZERO(CUT MAX)	The maximum cutting feedrate (parameter No. 1422) is set to 0 in the HPCC mode.

NOTE

For HPCC mode, refer to 7.1.14 HIGH PRECISION CONTOUR CONTROL.

Warning

WARNING

CNC calculation may involve a feedrate error of $\pm 2\%$ with respect to a specified value. However, this is not true for acceleration/deceleration. To be more specific, this error is calculated with respect to a measurement on the time the tool takes to move 500 mm or more during the steady state:

Reference item

Series 16i/18i/160i/180i/ 160is/180is	OPERATOR'S MANUAL (For Machining Center) (B-63534EN)	II.5.3	Cutting Feed
	OPERATOR'S MANUAL (For Lathe) (B-63524EN)	II.5.3	Cutting Feed
Series 21i/210i/210is	OPERATOR'S MANUAL (For Machining Center) (B-63614EN)	II.5.3	Cutting Feed
	OPERATOR'S MANUAL (For Lathe) (B-63604EN)	II.5.3	Cutting Feed
Series 20i	OPERATOR'S MANUAL (For Manual Milling Machine) (B-64204EN)	II.5.3	Cutting Feed
	OPERATOR'S MANUAL (For Manual Lathes) (B-64194EN)	II.5.3	Cutting Feed

**7.1.3
Feed Per Minute****General**

- **Feed per minute (G94)**

After specifying G94 (G98 for T series) (in the feed per minute mode), the amount of feed of the tool per minute is specified by setting a number after F. G94 (G98 for T series) is a modal code. Once a G94 (G98 for T series) is specified, it is valid until G95 (G99 for T series) (feed per revolution) is specified. At power-on, the feed per minute mode (feed per revolution mode for T series) is set.

An override from 0% to 254% (in 1% steps) can be applied to feed per minute with the feedrate override signal.

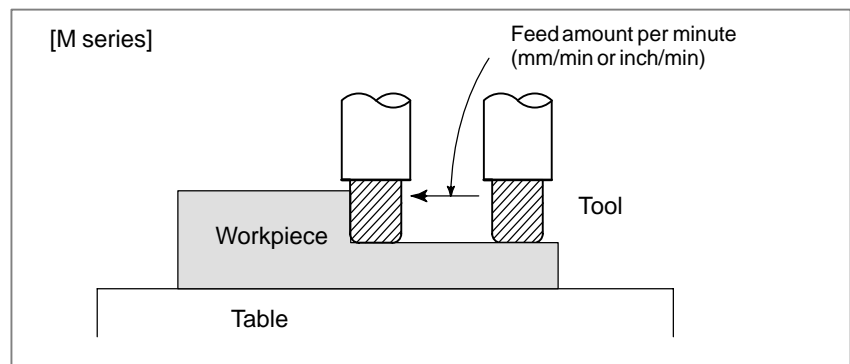
**Fig. 7.1.3 Feed per minute****CAUTION**

No override can be used for any commands such as for threading.

Format

For M series
 G94; G code for feed per minute (Group 05)
 F_; Feed rate (mm/min or inch/min)

For T series
 G98; G code for feed per minute (Group 05)
 F_; Feed rate (mm/min or inch/min)

Parameter

	#7	#6	#5	#4	#3	#2	#1	#0
1403								MIF

[Data type] Bit

MIF Cutting feedrates at feed per minute is specified by F commands

0 : In units of 1 mm/min for millimeter machines or 0.01 inches/min for inch machines.

1 : In unit of 0.001 mm/min for millimeter machines or 0.00001 inches/min for inch machines.

NOTE
 M series does not use this parameter. Cutting feedrates are specified by F commands in units of 0.001 mm/min for millimeter machines or 0.00001 inches/min for inch machines.

	#7	#6	#5	#4	#3	#2	#1	#0
3401							FCD	

[Data type] Bit

FCD When an F command and a G command (G98, G99) for feed per minute or feed per rotation are specified in the same block, and the G command (G98, G99) is specified after the F command, the F command is:

0 : Assumed to be specified in the mode (G98 or G99) when the F command is specified

1 : Assumed to be specified in the mode of the G command (G98 or G99) of the same block

NOTE

1 When FCD = 1:
If the block containing a G command (G98, G99) does not include an F command, the last F command specified is assumed to be specified in the G command mode of the block.

Example 1: N1 G99 ;

N2 Faaaa G98 ;

- Faaaa is assumed to be specified in the G98 mode.

N3 Fbbbb ;

- Fbbbb is assumed to be specified in the G98 mode.

N4 G99 ;

- Fbbbb is assumed to be specified in the G99 mode.

2 In G code system B or C, G98 and G99 function are specified in G94 and G95.

	#7	#6	#5	#4	#3	#2	#1	#0
3402			FPM					

[Data type] Bit

FPM When the power is turned on:

0 : Feed per revolution mode is entered.

1 : Feed per minute mode is entered.

Alarm and message

Number	Message	Description
011	NO FEEDRATE COMMANDED	Feedrate was not commanded to a cutting feed or the feedrate was inadequate. Modify the program.

Reference item

Series 16i/18i/160i/180i/ 160is/180is	OPERATOR'S MANUAL (For Machining Center) (B-63534EN)	II.5.3	Cutting feed
	OPERATOR'S MANUAL (For Lathe) (B-63524EN)	II.5.3	Cutting feed
Series 21i/210i/210is	OPERATOR'S MANUAL (For Machining Center) (B-63614EN)	II.5.3	Cutting feed
	OPERATOR'S MANUAL (For Lathe) (B-63604EN)	II.5.3	Cutting feed
Series 20i	OPERATOR'S MANUAL (For Manual Milling Machine) (B-64204EN)	II.5.3	Cutting Feed
	OPERATOR'S MANUAL (For Manual Lathes) (B-64194EN)	II.5.3	Cutting Feed

7.1.4 Feed Per Revolution/ Manual Feed Per Revolution

General

- **Feed per revolution**

After specifying G95 (G99 for T series) (in the feed per revolution mode), the amount of feed of the tool per spindle revolution is to be directly specified by setting a number after F. G95 (G99 for T series) is a modal code. Once a G95 is specified, it is valid until G94 (G98 for T series) (feed per minute) is specified.

An override of between 0 and 254% (in steps of 1%) can be applied to feed per rotation, using the feedrate override signals (*FV0 to *FV7). (See Subsection 7.1.7.2.)

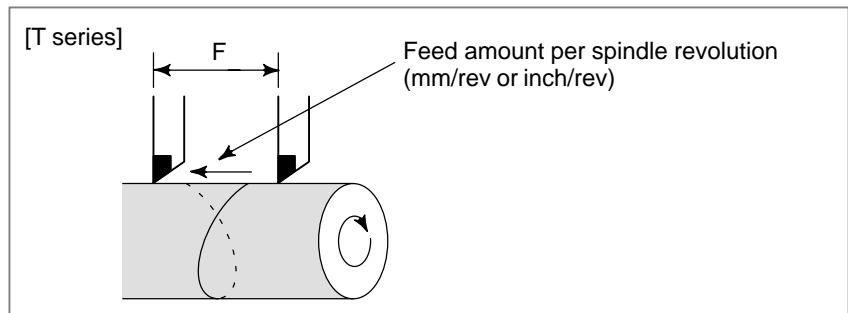

Fig. 7.1.4 Feed per revolution

- **Manual feed per revolution**

Jog feedrate can be specified by feed per revolution.

Parameter

	#7	#6	#5	#4	#3	#2	#1	#0
1402				JRV				NPC
								NPC

[Data type] Bit

JRV Jog feed

0 : Jog feed is performed at feed per minute.

1 : Jog feed is performed at feed per rotation.

NOTE

Specify a feedrate in parameter No. 1423.

NPC Feed per revolution command

0 : The feed per revolution command is ignored when the position coder is not installed.

1 : The feed per revolution command is accepted even when the position coder is not installed. (The CNC automatically converts the feed per revolution command to a feed-per-minute operation.)

1423

Feedrate in jog feed for each axis

[Data type] Word axis

When JRV, bit 4 of parameter No. 1402, is set to 1 (feed per revolution) in T series, specify a feedrate in jog feed (feed per revolution) with an override of 100% applied to the jog feedrate.

[Unit of data]**[Valid data range]**

Increment system	Unit of data	Valid data range
Millimeter machine	0.01 mm/rev	0 to 32767
Inch machine	0.001 inch/rev	
Rotation axis	0.01 deg/rev	

Caution**CAUTION**

When the speed of the spindle is low, feedrate fluctuation may occur. The slower the spindle rotates, the more frequently feedrate fluctuation occurs.

Reference item

Series 16i/18i/160i/180i/ 160is/180is	OPERATOR'S MANUAL (For Machining Center) (B-63534EN)	II.5.3	Cutting feed
	OPERATOR'S MANUAL (For Lathe) (B-63524EN)	II.5.3	Cutting feed
Series 21i/210i/210is	OPERATOR'S MANUAL (For Machining Center) (B-63614EN)	II.5.3	Cutting feed
	OPERATOR'S MANUAL (For Lathe) (B-63604EN)	II.5.3	Cutting feed
Series 20i	OPERATOR'S MANUAL (For Manual Milling Machine) (B-64204EN)	II.5.3	Cutting Feed
	OPERATOR'S MANUAL (For Manual Lathes) (B-64194EN)	II.5.3	Cutting Feed

7.1.5 One-digit F Code Feed (M series)

General

When a one-digit number from 1 to 9 is specified after F, the feedrate set for that number in a parameter (Nos. 1451 to 1459) is used. When F0 is specified, the rapid traverse rate is applied.

The feedrate corresponding to the number currently selected can be increased or decreased by turning on the switch for changing F1-digit feedrate on the machine operator's panel, then by rotating the manual pulse generator.

The increment/decrement, ΔF , in feedrate per scale of the manual pulse generator is as follows:

$$\Delta F = \frac{F_{\max}}{100X}$$

Fmax : feedrate upper limit for F1-F4 set by parameter 1460, or
feedrate upper limit for F5-F9 set by parameter 1461

X : any value of 1-127 set by parameter 1450

The feedrate set or altered is kept even while the power is off. The current feedrate is displayed on the screen.

Signal

F1-digit feed select signal F1D <G016#7>

[Classification] Input signal

[Function] Increases or decreases F1-digit speed set by the parameters No. 1451 to 1459 using the manual pulse generator.

Since the manual pulse generator may also be used for axis feeding, signal F1D (G016#7) designates which function may be used.

[Operation] When the signal is "1", the F1-digit speed can be increased/decreased using the manual pulse generator.

Signal address

	#7	#6	#5	#4	#3	#2	#1	#0
G016	F1D							

Parameter

1450	Number of revolution of manual pulse generator to reach maximum feedrate
------	--

[Data type] Byte

[Valid data range] 1 to 127

Set the constant that determines the change in feedrate as the manual pulse generator is rotated one graduation during F1-digit feed.

$$\Delta F = \frac{F_{maxi}}{100n} \text{ (where, } i=1 \text{ or } 2)$$

In the above equation, n is, the number of revolutions of the manual pulse generator, required to reach feedrate Fmaxi. Fmaxi refers to the upper limit of the feedrate for an F1-digit feed command, and set it in parameter 1460 or 1461.

Fmax1: Upper limit of the feedrate for F1 to F4 (parameter 1460)

Fmax2: Upper limit of the feedrate for F5 to F9 (parameter 1461)

1451	Feedrate for F1 digit command F1
1452	Feedrate for F1 digit command F2
1453	Feedrate for F1 digit command F3
1454	Feedrate for F1 digit command F4
1455	Feedrate for F1 digit command F5
1456	Feedrate for F1 digit command F6
1457	Feedrate for F1 digit command F7
1458	Feedrate for F1 digit command F8
1459	Feedrate for F1 digit command F9

These parameters can be set at “Setting screen”.

[Data type] Two-word

[Unit of data]

[Valid data range]

Increment system	Unit of data	Valid data range	
		IS-A, IS-B	IS-C
Millimeter machine	0.1 mm/min	6 – 150000	6 – 120000
Inch machine	0.01 inch/min	6 – 60000	6 – 48000
Rotation axis	0.1 deg/min	6 – 150000	6 – 120000

Set Feedrates for F1-digit feed commands F1 to F9.

When an F1-digit feed command is executed, as the feedrate is changed by turning the manual pulse generator, these parameter values also change accordingly.

1460	Upper limit of feedrate for the F1-digit feed command (F1 to F4)
1461	Upper limit of feedrate for the F1-digit feed command (F5 to F9)

[Data type] Two-word

[Unit of data]	Increment system	Unit of data	Valid data range	
			IS-A, IS-B	IS-C
[Valid data range]	Millimeter machine	1 mm/min	6 – 15000	6 – 12000
	Inch machine	0.1 inch/min	6 – 6000	6 – 4800
	Rotation axis	1 deg/min	6 – 15000	6 – 12000

Set the upper limit of feedrate for the F1-digit feed command.

As the feedrate increases by turning the manual pulse generator, the feedrate is clamped when it reaches the upper limit set. If an F1-digit feed command F1 to F4 is executed, the upper limit is that set in parameter 1460. If an F1-digit command F5 to F9 is executed, the upper limit is that set in parameter 1461.

Reference item

Series 16i/18i/160i/180i/ 160is/180is	OPERATOR'S MANUAL (For Machining Center) (B-63534EN)	II.5.3	Cutting feed
Series 21i/210i/210is	OPERATOR'S MANUAL (For Machining Center) (B-63614EN)	II.5.3	Cutting feed

7.1.6 Feedrate Inverse Time Specification (M series)

General

Feedrate of the tool can be specified by the move distance of the block and inverse time (FRN).

- **Linear interpolation
(G01)**

$$\text{FRN} = \frac{1}{\text{Time (min)}} = \frac{\text{Speed}}{\text{Distance}}$$

Speed: mm/min (metric input)
inch/min (inch input)
Distance: mm (metric input)
inch (inch input)

- **Circular interpolation
(G02, G03)**

$$\text{FRN} = \frac{1}{\text{Time (min)}} = \frac{\text{Speed}}{\text{Circle radius}}$$

Speed: mm/min (metric input)
inch/min (inch input)
Circle radius:
mm (metric input)
inch (inch input)

CAUTION

In circular interpolation, the distance is not an actual distance of the block but the speed is calculated from the circle radius.

Alarm and message

Number	Message	Description
011	NO FEEDRATE COM- MANDED	Feedrate was not commanded to a cutting feed, F0 was specified or the feedrate calculated (less than 0.001 mm/min, for metric input or less than 0.00001 inch for inch input) becomes less than an allowable range.

Reference item

Series 16i/18i/160i/180i/ 160is/180is	OPERATOR'S MANUAL (For Machining Center) (B-63534EN)	II.5.3	Cutting feed
Series 21i/210i/210is	OPERATOR'S MANUAL (For Machining Center) (B-63614EN)	II.5.3	Cutting feed

7.1.7 Override

7.1.7.1 Rapid traverse override

General

An override of four steps (F0, 25%, 50%, and 100%) can be applied to the rapid traverse rate. F0 is set by a parameter (No. 1421).

Also, 1% rapid traverse override select signal allows rapid traverse override every 1% in the range of 0 to 100%.

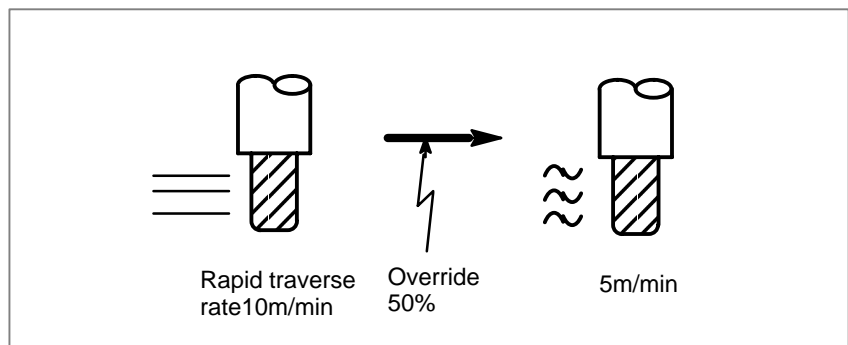

Fig.7.1.7.1 Rapid traverse override

- **Feedrate**

Actual feedrate is obtained by multiplying the rapid traverse rate preset by parameter no.1420 by the override value determined by this signal, whether in automatic or manual operation (including manual reference position return).

- **F0 rate**

For F0 value, an absolute value is set by parameter no.1421 within a range of 0 to rapid traverse rate (for each axis).

- **1% step rapid traverse override selection signal**

1% step rapid traverse override selection signal HROV determines whether rapid traverse override specified with rapid traverse override signals ROV1 and ROV2 is used or 1% step rapid traverse override is used.

When signal HROV is 0, override is applied to the rapid traverse rate using signals ROV1 and ROV2.

When signal HROV is 1, ROV1 and ROV2 are ignored, 1% step rapid traverse override signals *HROV0 to *HROV6 being used to override the rapid traverse rate.

- **PMC axis control**

These 1% step rapid traverse override signals are also effective to the rapid traverse rate for the PMC axis. When rapid traverse override is applied to the PMC axis (using signals ROV1E and ROV2E) with the setting of the OVE bit (bit 2 of parameter No. 8001) independently of the CNC, the 1% step rapid traverse override signals are ineffective.

Signal

**Rapid traverse override
signal
ROV1,ROV2
<G014#0, #1>**

[Classification] Input signal

[Function] These signals override the rapid traverse rate

[Operation] These code signals correspond to the rates as follows:

Rapid traverse override		Override value
ROV2	ROV1	
0	0	100 %
0	1	50 %
1	0	25 %
1	1	F0 %

Fo: Set in parameter No. 1421

**1% step rapid traverse
override selection signal
HROV <G096 #7>**

[Classification] Input signal

[Function] Selects the rapid traverse override signals or the 1% step rapid traverse override signals.

[Operation] When HROV is 1, signals *HROV0 to *HROV6 are effective and rapid traverse override with signals ROV1 and ROV2 is ignored.

When HROV is 0, signals *HROV0 to *HROV6 are ineffective, and rapid traverse override with signals ROV1 and ROV2 are effective.

**1% step rapid traverse
override signals
*HROV0 to *HROV6
<G096 #0 to #6>**

[Classification] Input signal

[Function] Applies override to the rapid traverse rate in the range of 0% to 100% in steps of 1%.

[Operation] These seven signals give a binary code indicating an override applied to the rapid traverse rate.

· When a binary code corresponding to an override value of 101% to 127% is specified, the applied override is clamped at 100%.

- Signals *HROV0 to *HROV6 are inverted signals.
To set an override value of 1%, set signals *HROV0 to *HROV6 to 1111110, which corresponds to a binary code of 0000001.

Signal address

	#7	#6	#5	#4	#3	#2	#1	#0
G014							ROV2	ROV1
G096	HROV	*HROV6	*HROV5	*HROV4	*HROV3	*HROV2	*HROV1	*HROV0

Parameter

1421	F0 rate of rapid traverse override for each axis
------	--

[Data type] Word axis

[Unit of data]

[Valid data range]

Increment system	Unit of data	Valid data range	
		IS-A, IS-B	IS-C
Millimeter machine	1 mm/min	30 – 15000	6 – 12000
Inch machine	0.1 inch/min	30 – 6000	6 – 4800
Rotation axis	1 deg/min	30 – 15000	6 – 12000

Set the F0 rate of the rapid traverse override for each axis.

	#7	#6	#5	#4	#3	#2	#1	#0
8001						OVE		

[Data type] Bit

OVE Dry run and override signals during axis control by the PMC

0 : Use the same signals as CNC

- (1) Feedrate override signal *FV0 to *FV7
- (2) Override cancel signal OVC
- (3) Rapid traverse override signals ROV1 and ROV2
- (4) Dry run signal DRN
- (5) Rapid traverse selection signal RT

1 : Use dedicated axis control signals by the PMC.

- (1) Feedrate override signal *FV0E to *FV7E
- (2) Override cancel signal OVCE
- (3) Rapid traverse override signals ROV1E and ROV2E
- (4) Dry run signal DRNE
- (5) Rapid traverse selection signal RTE

Reference item

Series 16i/18i/160i/180i/160is/180is	OPERATOR'S MANUAL (For Machining Center) (B-63534EN)	III.5.3	Rapid traverse override
	OPERATOR'S MANUAL (For Lathe) (B-63524EN)	III.5.3	Rapid traverse override
Series 21i/210i/210is	OPERATOR'S MANUAL (For Machining Center) (B-63614EN)	III.5.3	Rapid traverse override
	OPERATOR'S MANUAL (For Lathe) (B-63604EN)	III.5.3	Rapid traverse override
Series 20i	OPERATOR'S MANUAL (For Manual Milling Machine) (B-64204EN)	III.5.3	Rapid traverse override
	OPERATOR'S MANUAL (For Manual Lathes) (B-64194EN)	III.5.3	Rapid traverse override

7.1.7.2 Feedrate override

General

A programmed feedrate can be reduced or increased by a percentage (%) selected by the override dial. This feature is used to check a program. For example, when a feedrate of 100 mm/min is specified in the program, setting the override dial to 50% moves the tool at 50 mm/min.

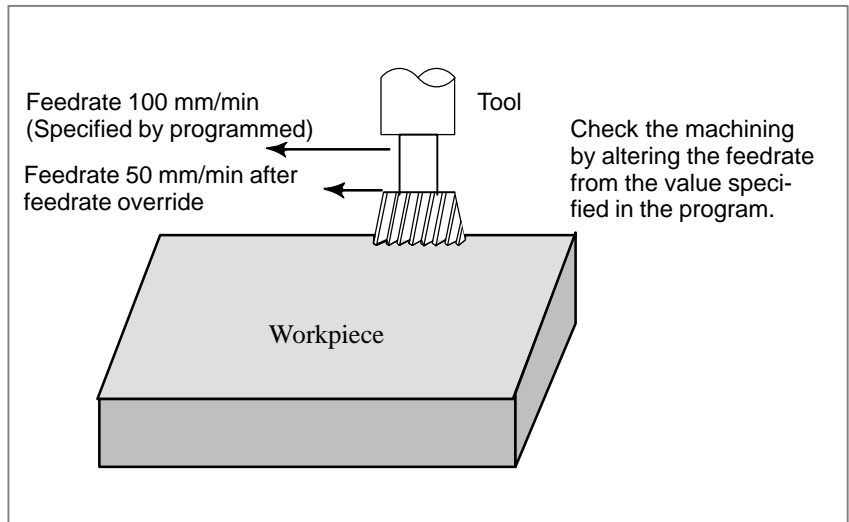

Fig. 7.1.7.2 Feedrate override

Signal

Feedrate Override signal

*FV0 to *FV7
<G012>

[Classification] Input signal

[Function] These signals override the cutting feedrate. Eight binary code signals correspond to override values as follows:

$$\text{Override value} = \sum_{i=0}^7 | 2^i \times V_i | \%$$

$V_i=0$ when *FVi is “1” and

$V_i=1$ when *FVi is “0”

These signals have the following weight.

*FV0 : 1%	*FV1 : 2%
*FV2 : 4%	*FV3 : 8%
*FV4 : 16%	*FV5 : 32%
*FV6 : 64%	*FV7 : 128 %

When all signals are “0”, they are regarded as overriding 0% in the same way as when all signals are “1” .

Thus, the override is selectable in steps over a range of 0 to 254%.

[Operation] Actual feedrate is obtained by multiplying the specified speed by the override value selected by this signal.

The override is regarded as 100%, regardless of this signal, in the following cases:

- Override cancel signal OVC is “1”.
- During cutting in tap cycle of canned cycle;
- Tapping mode (G63); or
- Thread cutting is in progress.

Same examples are listed below.

*FV0 – *FV7		Override value (%)
4	0	
1 1 1 1	1 1 1 1	0
1 1 1 1	1 1 1 0	1
1 1 1 1	1 1 0 1	2
1 1 1 1	1 1 0 0	3
1 1 1 1	1 0 1 1	4
1 1 1 1	1 0 1 0	5
1 1 1 1	0 1 0 1	10
1 1 1 1	0 0 0 0	15
1 1 1 0	1 0 1 1	20
1 1 1 0	0 1 1 0	25
1 1 1 0	0 0 0 1	30
1 1 0 1	1 1 0 0	35
1 1 0 1	0 1 1 1	40
1 1 0 1	0 0 1 0	45
1 1 0 0	1 1 0 1	50
1 1 0 0	0 0 1 1	60
1 0 1 1	1 0 0 1	70
1 0 1 0	1 1 1 1	80
1 0 1 0	0 1 0 1	90
1 0 0 1	1 0 1 1	100
0 1 1 0	1 0 0 1	150
0 0 1 1	0 1 1 1	200
0 0 0 0	0 0 0 1	254
0 0 0 0	0 0 0 0	0

The value is calculated as follows.

1. In case that the override is 2%,
 - (1) Convert to binary data. 0000 0010
 - (2) Do logical NOT of binary data. 1111 1101
2. In case that the input signal is "1110 1110",
 - (1) Do logical NOT of binary data. 0001 0001
 - (2) Convert to decimal data. 17%

Signal address

	#7	#6	#5	#4	#3	#2	#1	#0
G012	*FV7	*FV6	*FV5	*FV4	*FV3	*FV2	*FV1	*FV0

Parameter

	#7	#6	#5	#4	#3	#2	#1	#0
1401				RFO				

[Data type] Bit

- RFO** When cutting feedrate override is 0% during rapid traverse,
 0 : The machine tool does not stop moving.
 1 : The machine tool stops moving.

Reference item

Series 16i/18i/160i/180i/ 160is/180is	OPERATOR'S MANUAL (For Machining Center) (B-63534EN)	II.5.3	Cutting feed
	OPERATOR'S MANUAL (For Lathe) (B-63524EN)	II.5.3	Cutting feed
Series 21i/210i/210is	OPERATOR'S MANUAL (For Machining Center) (B-63614EN)	II.5.3	Cutting feed
	OPERATOR'S MANUAL (For Lathe) (B-63604EN)	II.5.3	Cutting feed
Series 20i	OPERATOR'S MANUAL (For Manual Milling Machine) (B-64204EN)	II.5.3	Cutting Feed
	OPERATOR'S MANUAL (For Manual Lathes) (B-64194EN)	II.5.3	Cutting Feed

7.1.7.3

Second feedrate override

General

These signals override the cutting feedrate after the cutting feedrate has been overridden by first override *FV0 to *FV7.

Signal

**Second feedrate override
signal *AFV0 to *AFV7
<G013>**

These eight binary code signals correspond to the override values as follows.

$$\text{Override value} = \sum_{i=0}^7 | 2^i \times V_i | \%$$

$V_i=0$ when *AFVi is "1" and

$V_i=1$ when *AFVi is "0"

These signals have the following weight.

*AFV0 : 1%	*AFV1 : 2%
*AFV2 : 4%	*AFV3 : 8%
*AFV4 : 16%	*AFV5 : 32%
*AFV6 : 64%	*AFV7 : 128 %

If all signals are "0" or "1", the override is regarded as 0%. The override is selectable in steps over a range of 0 to 254%.

Signal address

	#7	#6	#5	#4	#3	#2	#1	#0
G013	*AFV7	*AFV6	*AFV5	*AFV4	*AFV3	*AFV2	*AFV1	*AFV0

7.1.7.4**Override cancel****General**

The override cancel signal fixes the feedrate override to 100%.

Signal**Override cancel signal****OVC <G006#4>**

[Classification] Input signal

[Function] Feedrate override is fixed to 100%.

[Operation] When the signal is “1”, the CNC operates as follows:

- Feedrate override is fixed to 100% irrespective of feedrate override signal.
- Rapid traverse override and spindle speed override are not affected.

Signal address

	#7	#6	#5	#4	#3	#2	#1	#0
G006				OVC				

7.1.8 Automatic Corner Override (M series)

General

- **Inner corner automatic override**

When G62 is specified, and the tool path with cutter compensation applied forms an inner corner, the feedrate is automatically overridden at both ends of the corner.

There are four types of inner corners (Fig. 7.1.8).

$2^\circ \leq \theta \leq \theta_p \leq 178^\circ$ in Fig. 7.1.8

θ_p is a value set with parameter No. 1711. When θ is approximately equal to θ_p , the inner corner is determined with an error of 0.001, or less.

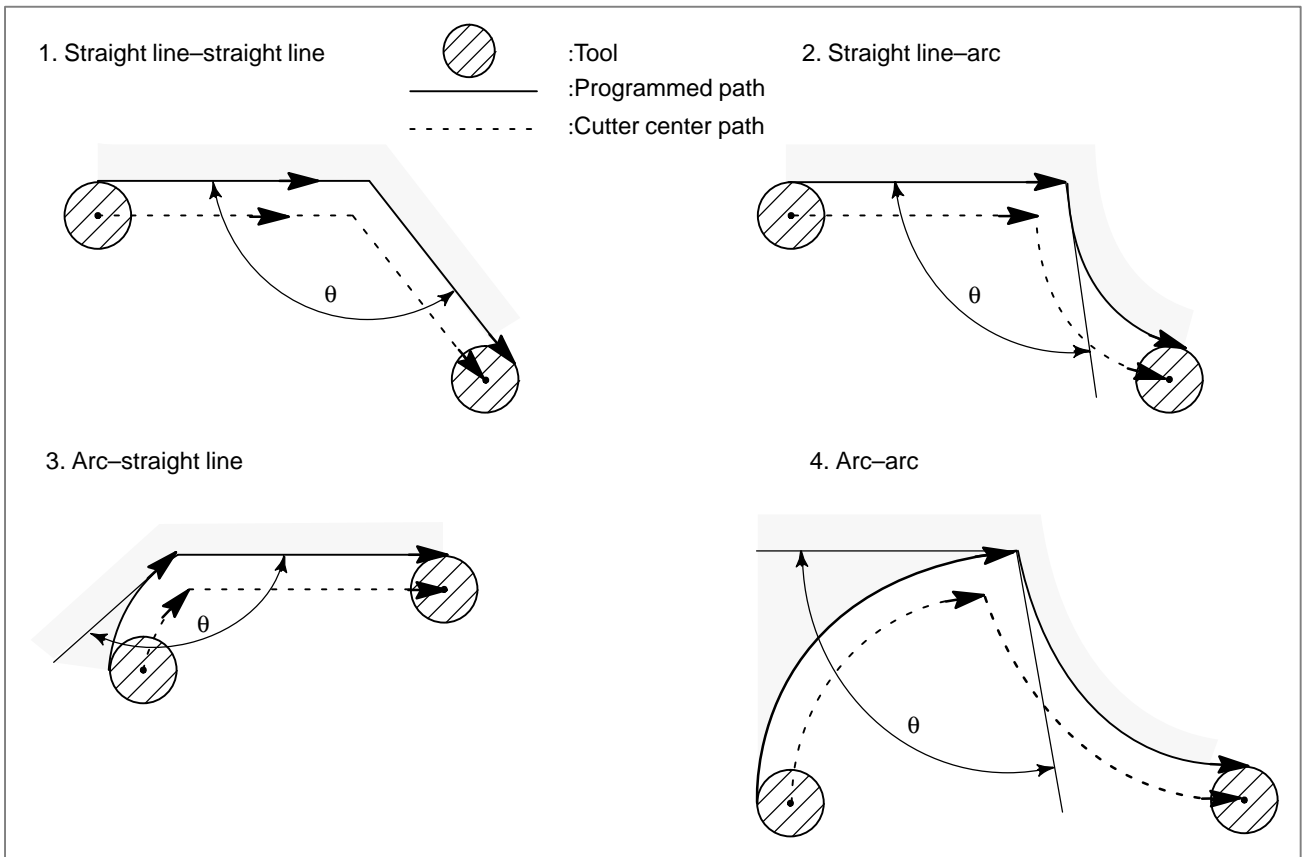

Fig. 7.1.8 Inner corner

WARNING

When the block before a corner is a start-up block, or the block after a corner includes G41 or G42, the feedrate is not overridden. The feedrate override function is disabled when the offset value is 0.

- **Override value**

An override value is set with parameter No. 1712. An override value is valid even for dry run and F1-digit feed specification.

In the feed per minute mode, the actual feedrate is as follows:

$$F \times (\text{inner corner automatic override}) \times (\text{feedrate override})$$

- **Internal circular cutting feedrate change**

For internally offset circular cutting, the feedrate on a programmed path is set to a specified feedrate (F) by specifying the circular cutting feedrate with respect to F, as indicated below. This function is valid in the cutter compensation mode, regardless of the G62 code.

$$F \times \frac{R_c}{R_p}$$

R_c : Cutter center path radius

R_p : Programmed radius

It is also valid for the dry run and the F1-digit feed command.

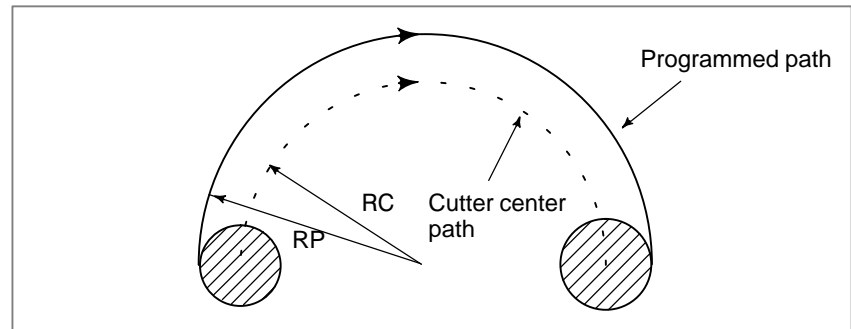

Internal circular cutting feedrate change

If R_c is much smaller than R_p, R_c/R_p ≠ 0; the tool stops. A minimum deceleration ratio (MDR) is to be specified with parameter No. 1710. When R_c/R_p ≤ MDR, the feedrate of the tool is (F×MDR).

CAUTION

When internal circular cutting must be performed together with automatic override for inner corners, the feedrate of the tool is as follows:

$$F \times \frac{R_c}{R_p} \times (\text{inner corner override}) \times (\text{feedrate override})$$

Parameter

1710

Minimum deceleration ratio (MDR) of the inner circular cutting rate in automatic corner override

[Data type] Byte

[Unit of data] %

[Valid data range] 1 to 100

Set the minimum deceleration ratio (MDR) in changing the inner circular cutting feedrate by automatic corner override.

In circular cutting with an inward offset, the actual feedrate for a specified feedrate (F) becomes as follows:

$$F \times \frac{R_c}{R_p} \quad \left(\begin{array}{l} R_c: \text{Radius of the path of the cutter's center} \\ R_p: \text{Programmed radius} \end{array} \right)$$

As the actual feedrate becomes the value obtained from the above equation, the specified rate F can be achieved on the program path.

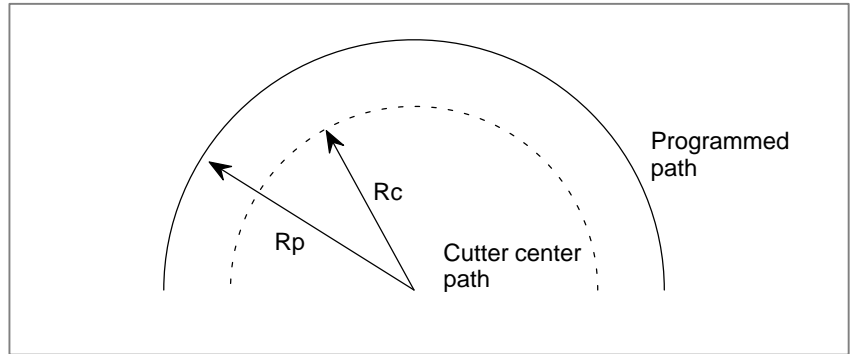

If R_c is too small in comparison with R_p so that $\frac{R_c}{R_p} \cong 0$, the cutter will stop. To prevent this, the minimum deceleration ratio (MDR) is set.

When $\frac{R_c}{R_p} \cong 0$,

the actual rate becomes as follows:

$$F \times (\text{MDR})$$

1711	Angle (θ_p) to recognize the inner corner in automatic override
------	--

[Data type] Byte

[Unit of data] Degree

[Valid data range] 1 to 179 (standard value = 91)

Set the angle to recognize the inner corner when automatic corner override is performed for the inner corner.

1712	Amount of automatic override for an inner corner
------	--

[Data type] Byte

[Unit of data] %

[Valid data range] 1 to 100

Set inner corner automatic override value when automatic corner override is performed.

1713 Distance Le from the starting point in inner corner automatic override

[Data type] Word

[Unit of data]	Increment system	IS-A	IS-B	IS-C	Unit
	Input in mm	1	0.1	0.01	mm
	Input in inches	0.1	0.01	0.001	inch

[Valid data range] 0 to 3999

Set distance Le from the starting point in an inner corner for automatic corner override.

1714 Distance Ls up to the ending point in inner corner automatic override

[Data type] Word

[Unit of data]	Increment system	IS-A	IS-B	IS-C	Unit
	Input in mm	1	0.1	0.01	mm
	Input in inches	0.1	0.01	0.001	inch

[Valid data range] 0 to 3999

Set distance Ls up to the end point in an inner corner for automatic corner override.

If $\theta \leq \theta_p$, the inside of a corner is recognized. (θ is set in parameter 1711.)

When an inner corner is recognized, the feedrate is overridden in the range of Le in the block immediately before the intersection of the corner and Ls in the next block following the intersection.

Ls and Le are each a straight line connecting the intersection of the corner and a given point on the path of the cutter's center.

Ls and Le are set in parameters 1713 and 1714.

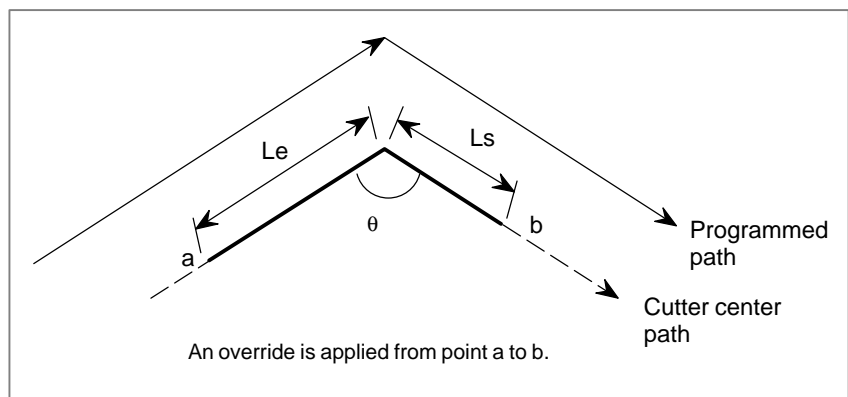

Reference item

Series 16i/18i/160i/180i/ 160is/180is	OPERATOR'S MANUAL (For Machining Center) (B-63534EN)	II.5.4.2	Automatic Override for Inner Corners
Series 21i/210i/210is	OPERATOR'S MANUAL (For Machining Center) (B-63614EN)	II.5.4.2	Automatic Override for Inner Corners

7.1.9 External Deceleration

General

These signals decelerate the feedrate of the control axes down to the speed which has been set by parameter No. 1426 and 1427.

Signal

External deceleration signal

*+ED1 to *+ED8<G118>

*-ED1 to *-ED8<G120>

[Classification] Input signal

[Function] These signals are used to apply deceleration, and provided for each direction of each control axis; +/– indicates the direction, while the signal number corresponds to the number of the controlled axis.

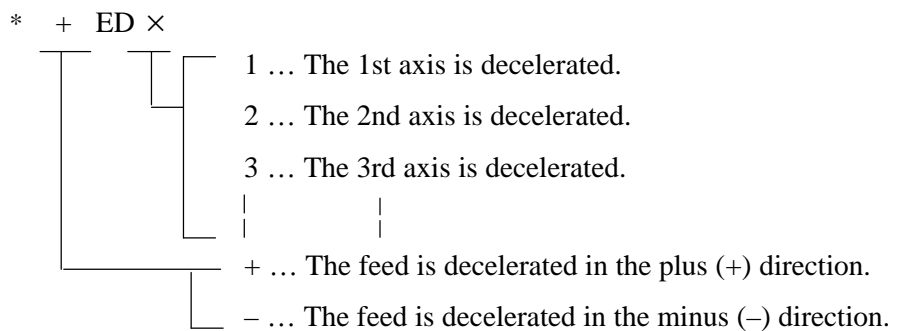

[Operation] When a signal becomes “0”, the corresponding axis decelerates to stop in the specified direction.

Signal address

	#7	#6	#5	#4	#3	#2	#1	#0
G118	*+ED8	*+ED7	*+ED6	*+ED5	*+ED4	*+ED3	*+ED2	*+ED1
G120	*-ED8	*-ED7	*-ED6	*-ED5	*-ED4	*-ED3	*-ED2	*-ED1

Parameter

	#7	#6	#5	#4	#3	#2	#1	#0
1005			EDMx	EDPx				

[Data type] Bit axis

EDPx External deceleration signal in the positive direction for each axis
 0 : Valid only for rapid traverse
 1 : Valid for rapid traverse and cutting feed

EDMx External deceleration signal in the negative direction for each axis
 0 : Valid only for rapid traverse
 1 : Valid for rapid traverse and cutting feed

1426	External deceleration rate of cutting feed
------	--

[Data type] Word

[Unit of data]

[Valid data range]

Increment system	Unit of data	Valid data range	
		IS-A, IS-B	IS-C
Millimeter machine	1 mm/min	6 - 15000	6 - 12000
Inch machine	0.1 inch/min	6 - 6000	6 - 4800

Set the external deceleration rate of cutting feed.

1427	External deceleration rate of rapid traverse for each axis
------	--

[Data type] Word axis

[Unit of data]

[Valid data range]

Increment system	Unit of data	Valid data range	
		IS-A, IS-B	IS-C
Millimeter machine	1 mm/min	6 - 15000	6 - 12000
Inch machine	0.1 inch/min	6 - 6000	6 - 4800
Rotation axis	1 deg/min	6 - 15000	6 - 12000

Set the external deceleration rate of rapid traverse for each axis.

7.1.10 Feed Stop Function

General

During axis motion, the feed stop function checks a position deviation amount at all times. When the amount exceeds the “feed stop position deviation amount” set by the parameter (No. 1832), the function suspends pulse distribution and acceleration/deceleration control during such a period of time, and terminates the move command for the positioning control circuit. Thus the function can minimize an overshoot that may occur with a large servo motor in rapid traverse acceleration operation.

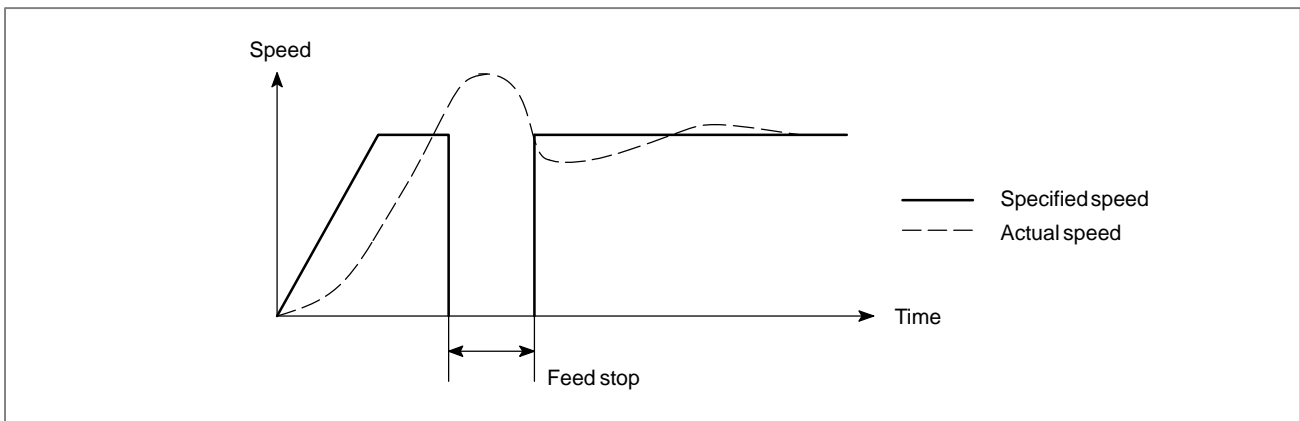

Parameter

1832	Feed stop positioning deviation for each axis
------	---

[Data type] Two-word axis

[Unit of data] Detection unit

[Valid data range] 0 to 99999999

Set the feed stop positioning deviation for each axis.

If the positioning deviation exceeds the feed stop positioning deviation during movement, pulse distribution and acceleration/deceleration control are stopped temporarily. When the positioning deviation drops to the feed stop positioning deviation or below, pulse distribution and acceleration/deceleration control are resumed.

The feed stop function is used to reduce overshoot in acceleration/deceleration mainly by large servo motor.

Generally, set the middle value between the positioning deviation limit during movement and the positioning deviation at rapid traverse as the feed stop positioning deviation.

7.1.11 Feedrate Clamping by Arc Radius (M series)

General

When an arc is cut at a high speed in circular interpolation, a radial error exists between the actual tool path and the programmed arc. An approximation of this error can be obtained from the following expression:

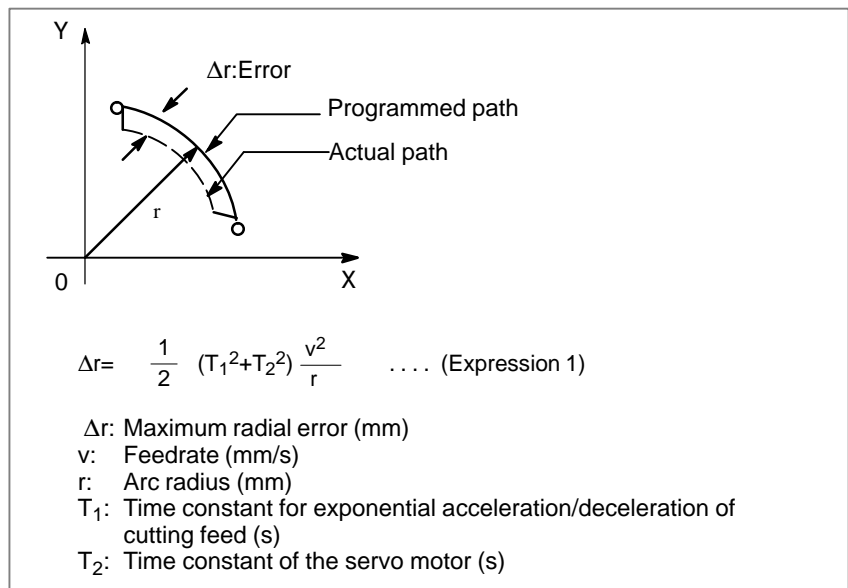

When actual machining is performed, radius r of the arc to be machined and permissible error Δr are given. Then, maximum allowable feedrate v (mm/min) is determined from the above expression.

The function for clamping the feedrate by the arc radius automatically clamps the feedrate of arc cutting to the value set in a parameter. This function is effective when the specified feedrate may cause the radial error for an arc with a programmed radius to exceed the permissible degree of error.

When the permissible error Δr is determined, the maximum permissible speed V for the arc radius R is obtained from expression 2.

$$\Delta r = \frac{1}{2} (T_1^2 + T_2^2) \frac{V^2}{R} \dots \dots \text{(Expression 2)}$$

For the arc radius r , the maximum permissible speed v to set the permissible error to Δr is obtained from expression 1. From expressions 1 and 2, the following expression is obtained:

$$\frac{1}{2} (T_1^2 + T_2^2) \frac{v^2}{r} = \frac{1}{2} (T_1^2 + T_2^2) \frac{V^2}{R}$$

$$\therefore v = \sqrt{\frac{r}{R}} V \dots \dots \text{(Expression 3)}$$

When a given arc radius R and the maximum permissible speed V for that arc radius are set as parameters, the maximum permissible speed v for an arc with a programmed radius r can be obtained from expression 3. Then, if a specified feedrate exceeds the speed v, the feedrate is automatically clamped to the speed v.

The maximum permissible speed v obtained from expression 3 decreases with the specified arc radius. To prevent the maximum permissible speed from decreasing excessively, the lower limit imposed on the maximum permissible speed v can be set in parameter 1732.

Provided the specified feedrate does not exceed the maximum permissible speed v obtained from expression 3, arc cutting is performed at the specified feedrate.

● **Cutting feed linear acceleration/deceleration**

When the cutting feed linear acceleration/deceleration function is used, an approximate error in arc cutting can be obtained from expression 4.

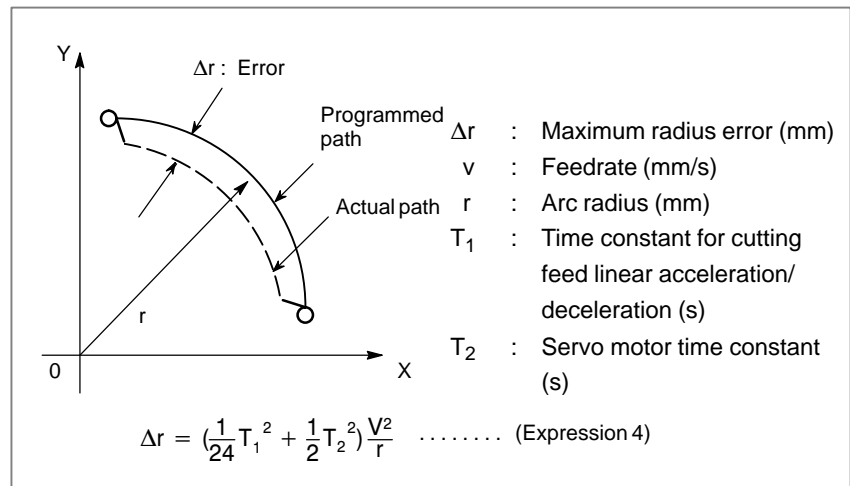

As can be seen from expression 4, expression 3 also holds for linear acceleration/deceleration after interpolation. Therefore, feedrate clamping by the arc radius is enabled.

● **Actual error**

Expressions 1, 2, and 4 logically denote an approximate error in the CNC. They do not denote an actual error in machining.

Let the actual error in machining be Δr_{all} . Then, it is expressed as follows:

$$\Delta r_{all} = \Delta r_{NC} + \Delta r_{machine} \dots \dots \dots \text{(Expression 5)}$$

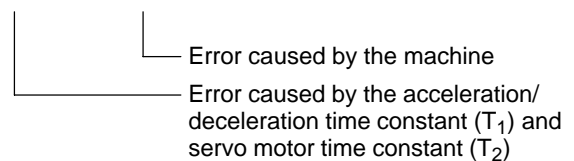

This function controls only the first term on the right side of expression 5. In other words, this function suppresses only the error caused by the acceleration/deceleration time constant (T_1) and servo motor time constant (T_2) to a certain level. This function does not control the error caused by the machine.

Expressions 1, 2, and 4 are approximate expressions. This means that, as the arc radius becomes smaller, the approximate precision lowers. Therefore, even when the feedrate is clamped to the maximum permissible speed v obtained from expression 3, the permissible error may be exceeded.

Parameter

1730	Maximum feedrate for arc radius R
------	-----------------------------------

[Data type] Word

[Unit of data] [Valid data range]	Increment system	Unit of data	Valid data range	
			IS-A, IS-B	IS-C
	Millimeter machine	1 mm/min	8 – 15000	0 – 12000
	Inch machine	0.1 inch/min	8 – 6000	0 – 4800

Set a maximum feedrate for the arc radius set in parameter No. 1731.

1731	Arc radius value corresponding to a maximum feedrate
------	--

[Data type] Two-word

[Unit of data]	Unit	IS-A	IS-B	IS-C	Unit
	Linear axis (millimeter machine)	0.01	0.001	0.0001	mm
	Linear axis (inch machine)	0.001	0.0001	0.00001	inch

[Valid data range] 1000 to 99999999

Set the arc radius corresponding to the maximum feedrate set in parameter No. 1730.

1732	Minimum value (RV min) for arc radius-based feedrate clamp
------	--

[Data type] Word

[Unit of data] [Valid data range]	Increment system	Unit of data	Valid data range	
			IS-A, IS-B	IS-C
	Millimeter machine	1 mm/min	0 – 15000	0 – 12000
	Inch machine	0.1 inch/min	0 – 6000	0 – 4800

The arc radius-based feedrate clamping function reduces the maximum feedrate as the arc radius decreases. When the specified maximum feedrate is not greater than RV min (minimum value for arc radius-based feedrate clamping), RV min is used as the maximum feedrate.

Reference item

Series 16i/18i/160i/180i/ 160is/180is	OPERATOR'S MANUAL (For Machining Center) (B-63534EN)	II.19.2	Feedrate clamp by circle radius
Series 21i/210i/210is	OPERATOR'S MANUAL (For Machining Center) (B-63614EN)	II.19.1	Feedrate clamp by circle radius

7.1.12 Automatic Corner Deceleration

General

This function automatically controls the feedrate during corner machining according to the angle of a corner made by machining blocks or according to the feedrate difference for each axis.

This function is enabled when G64 (machining) mode (M series) is selected and deceleration of the first of two consecutive cutting feed blocks is executed.

Feedrate control can be performed according to the angle of a corner made by machining blocks or according to the feedrate difference for each axis. The desired method is selected by specifying the corresponding value in the CSD bit (bit 4 of parameter No. 1602).

Feedrate control according to corner angle

• Overview

If the angle made by blocks A and B is smaller than that specified in parameter No. 1740 (for the selected plane), and if the feedrates along the first and second axes on that plane are lower than that specified in parameter No. 1741, the system executes block B, assuming that no pulses are accumulated.

The figure shows the relationship between feedrate and time when a corner angle is smaller than the angle specified in the parameter.

At time t , some accumulated pulses remain, as indicated by the shaded part. The system, however, starts the next block because the feedrate of the automatic acceleration/deceleration circuit is lower than that specified in the parameter.

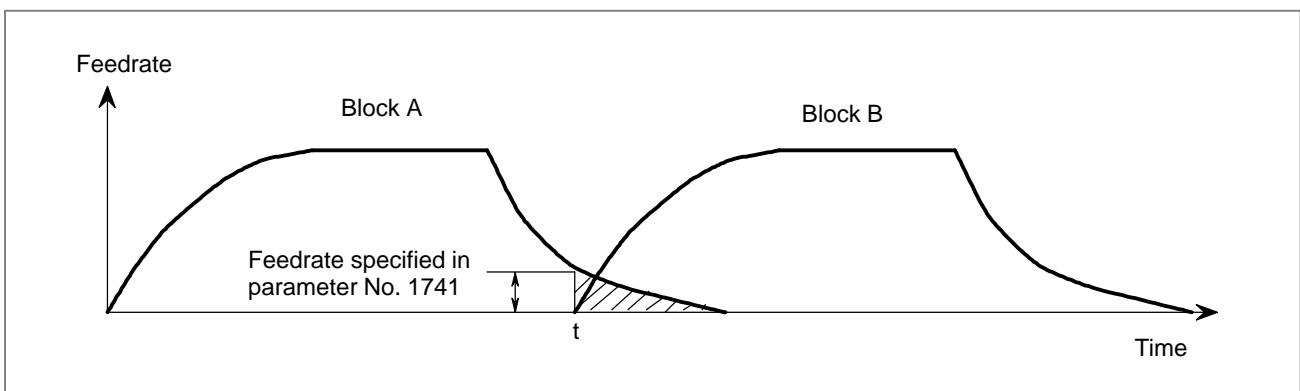

• **When linear acceleration/deceleration before interpolation for cutting feed is enabled**

If the angle made by blocks A and B is smaller than that specified in parameter No. 1740 (for the selected plane), and if the feedrates programmed for blocks A and B are higher than the value set in parameter No. 1778, the feedrate is reduced to the value specified in the parameter in block A. In block B, the feedrate is increased to the programmed feedrate. The rate of acceleration depends on the parameter for linear acceleration/deceleration before interpolation for cutting feed.

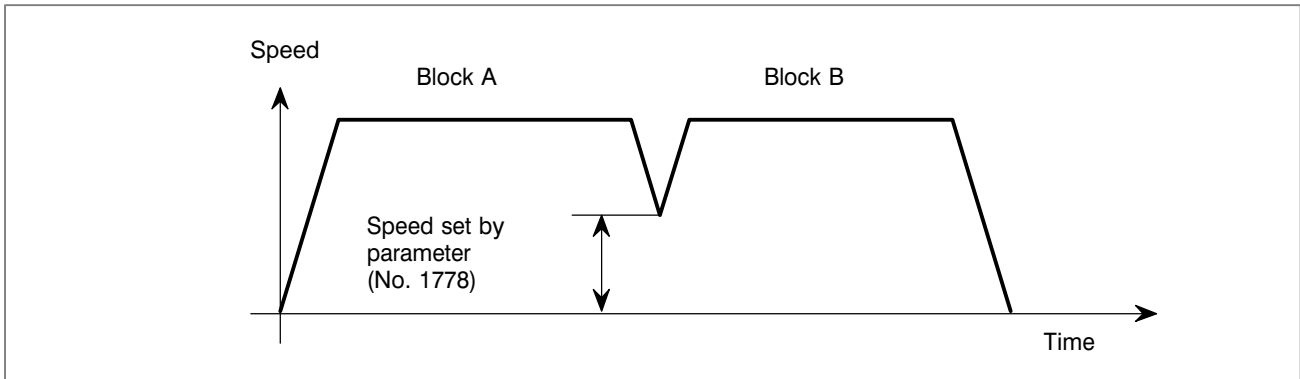

• **Parameter**

	#7	#6	#5	#4	#3	#2	#1	#0
1601		ACD						

[Data type] Bit

ACD Function for automatically reducing the feedrate at corners (automatic corner deceleration function)

- 0 : The function is not used.
- 1 : The function is used.

	#7	#6	#5	#4	#3	#2	#1	#0
1602				CSD				

[Data type] Bit

CSD In the function for automatically reducing a feedrate at corners,

- 0 : Angles are used for controlling the feedrate.
- 1 : Differences in feedrates are used for controlling the feedrate.

1740	Critical angle subtended by two blocks for automatic corner deceleration
------	--

[Data type] Two-word

[Unit of data] 0.001 deg

[Valid data range] 0 to 180000

Set a critical angle to be subtended by two blocks for corner deceleration when the angle-based automatic corner deceleration function is used.

The angle subtended by two blocks is defined as θ in the examples shown below.

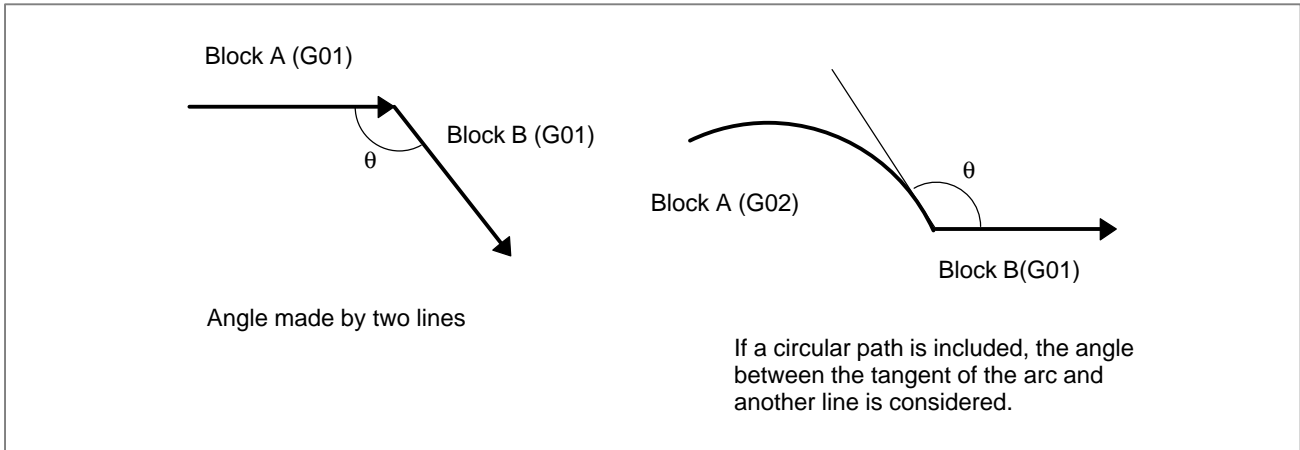

1741 Feedrate for assuming the termination of automatic corner deceleration (for acceleration/deceleration after interpolation)

[Data type] Word axis

[Unit of data]

[Valid data range]

Increment system	Unit of data	Valid data range	
		IS-A, IS-B	IS-C
Millimeter machine	1 mm/min	6 - 15000	6 - 12000
Inch machine	0.1 inch/min	6 - 6000	6 - 4800
Rotation axis	1 deg/min	6 - 15000	6 - 12000

Set the feedrate for assuming the termination of deceleration in automatic corner deceleration.

1778 Minimum speed for the automatic corner deceleration function (for linear acceleration/deceleration before interpolation)

[Data type] Word

[Unit of data]

[Valid data range]

Increment system	Unit of data	Valid data range	
		IS-A, IS-B	IS-C
Millimeter machine	1 mm/min	6 - 15000	6 - 12000
Inch machine	0.1 inch/min	6 - 6000	6 - 4800
Rotation axis	1 deg/min	6 - 15000	6 - 12000

Set a speed at which the number of buffered pulses in deceleration is assumed to be 0 when linear acceleration/deceleration before interpolation is used.

Caution**CAUTION**

- 1 The angle of the machining tool path is compared with that specified in parameter No. 1740 only for the selected plane. The actual feedrate and that specified in parameter No. 1741 are compared only for the first and second axes of the selected plane. Even if simultaneous movement is performed along three or more axes, the feedrates of only the first and second axes are compared for the selected plane.
- 2 The roundness of a corner is determined by the angle and feedrate specified in parameter Nos. 1740 and 1741, respectively. If a sharp corner is always required, set a feedrate of zero and an angle of 180000 (180 degrees).
- 3 If a G09 (exact stop) command is executed, an exact stop is performed, and Automatic Corner Deceleration is not executed. (M series)
- 4 This function is disabled in single block and dry run mode.

Feedrate control according to the feedrate difference for each axis

- Overview

If the difference between the programmed feedrates at the end of block A and at the beginning of block B for each axis exceeds the value specified in parameter No. 1781, and if the feedrates for all axes are lower than that specified in parameter No. 1741, the system executes block B, assuming that no pulses are accumulated.

The figure shows the relationship between the feedrate and time when the feedrate difference for each axis exceeds the value specified in parameter No. 1781.

At time t , some accumulated pulses remain, as indicated by the shaded section. The system, however, starts the next block because the feedrate of the automatic acceleration/deceleration circuit is lower than that specified in parameter No. 1741.

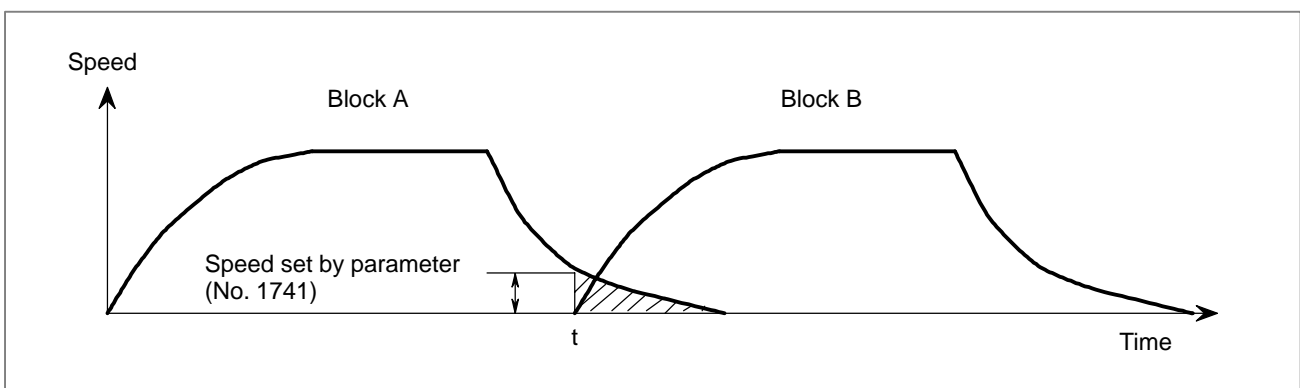

· **When linear acceleration/deceleration before interpolation for cutting feed is enabled**

If the difference between the feedrates of blocks A and B for each axis exceeds the value specified in parameter No. 1780, the feedrate at the corner is calculated from the difference for each axis, as shown below. The feedrate is reduced to the calculated value in block A.

The feedrate change for each axis ($V_c[X]$, $V_c[Y]$, ...), caused by the movement at programmed feedrate F , is compared with V_{max} specified in parameter No. 1780. If an feedrate change exceeding V_{max} is detected, the target feedrate after deceleration F_c is calculated, using maximum comparison value R_{max} .

$$R = \frac{V_c}{V_{max}}$$

$$F_c = \frac{F}{R_{max}}$$

If, for example, the direction of movement is changed from the X-axis to the Y-axis, that is through 90 degrees, and if the programmed feedrate is 1000 mm/min and the permissible feedrate difference specified in parameter No. 1780 is 500 mm/min, the deceleration shown below is performed:

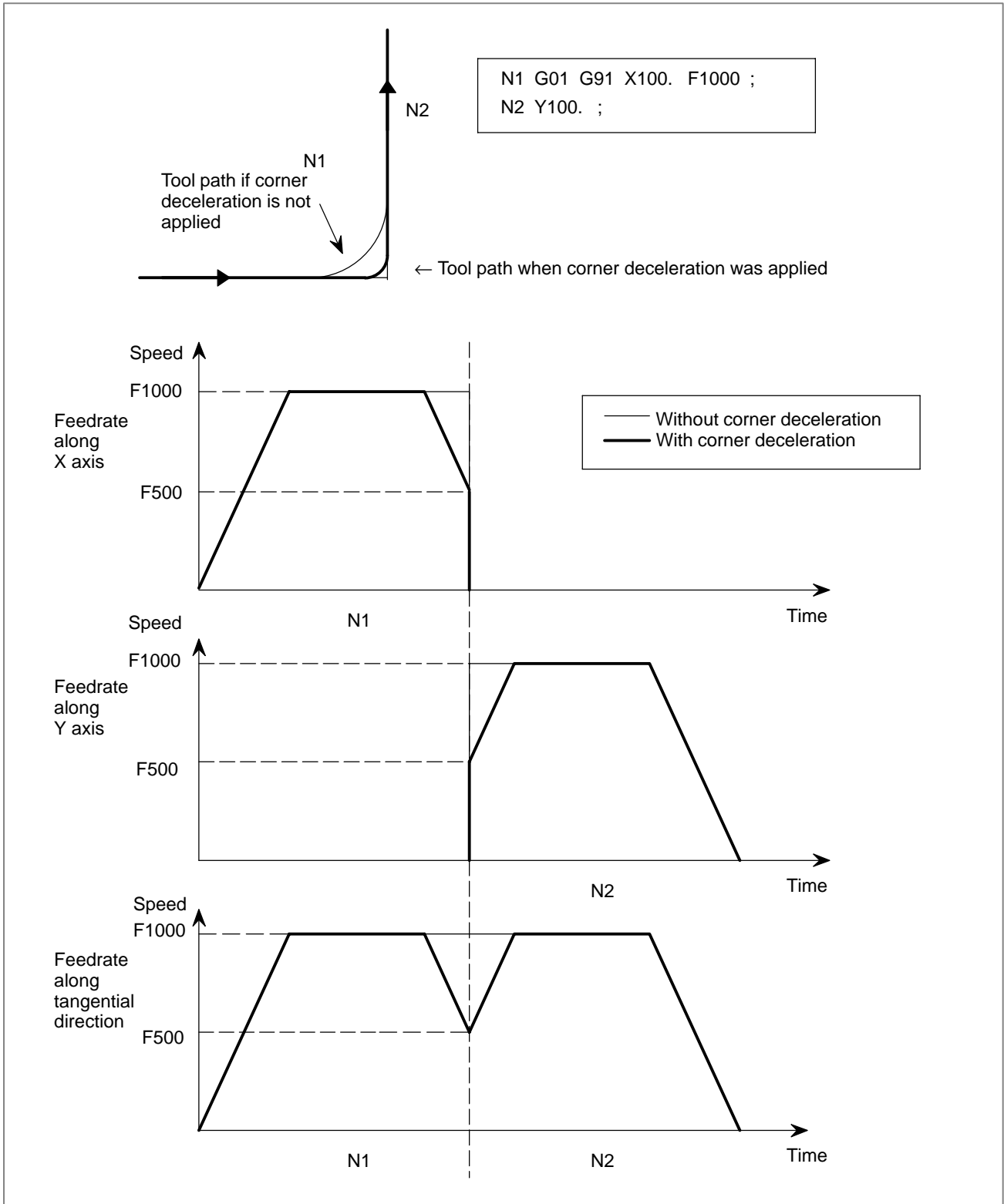

Different permissible feedrate differences can be specified for different axes. If a value is specified in parameter No. 1783, the permissible feedrate difference for each axis becomes valid. Deceleration at a corner is calculated for the axis for which the permissible feedrate difference is exceeded with the highest ratio of actual feedrate difference to permissible feedrate difference.

● Parameter

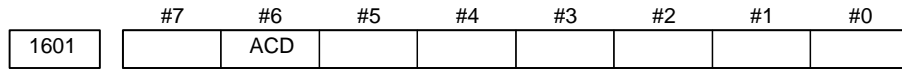

[Data type] Bit

ACD Function for automatically reducing the feedrate at corners (automatic corner deceleration function)

0 : The function is not used.

1 : The function is used.

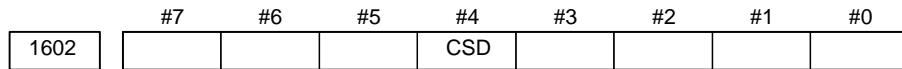

[Data type] Bit

CSD In the function for automatically reducing a feedrate at corners,

0 : Angles are used for controlling the feedrate.

1 : Differences in feedrates are used for controlling the feedrate.

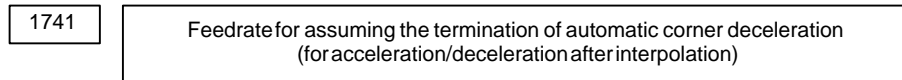

[Data type] Word axis

[Unit of data]

[Valid data range]

Increment system	Unit of data	Valid data range	
		IS-A, IS-B	IS-C
Millimeter machine	1 mm/min	6 – 15000	6 – 12000
Inch machine	0.1 inch/min	6 – 6000	6 – 4800
Rotation axis	1 deg/min	6 – 15000	6 – 12000

Set the feedrate for assuming the termination of deceleration in automatic corner deceleration.

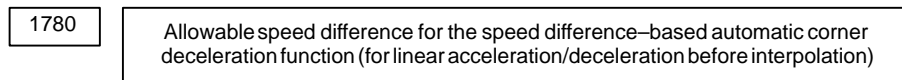

[Data type] Word

[Unit of data]

[Valid data range]

Increment system	Unit of data	Valid data range	
		IS-A, IS-B	IS-C
Millimeter machine	1 mm/min	6 – 15000	6 – 12000
Inch machine	0.1 inch/min	6 – 6000	6 – 4800

Set the speed difference for the speed difference-based automatic corner deceleration function when linear acceleration/deceleration before interpolation is used.

1781

Allowable speed difference for the speed difference-based automatic corner deceleration function (for acceleration/deceleration after interpolation)

[Data type] Word axis

[Unit of data]

[Valid data range]

Increment system	Unit of data	Valid data range	
		IS-A, IS-B	IS-C
Millimeter machine	1 mm/min	6 – 15000	6 – 12000
Inch machine	0.1 inch/min	6 – 6000	6 – 4800
Rotation axis	1 deg/min	6 – 15000	6 – 12000

Set a speed difference for the speed difference-based automatic corner deceleration function when acceleration/deceleration after interpolation is used.

1783

Allowable feedrate difference in automatic corner deceleration based on the feedrate difference (for linear acceleration/deceleration before interpolation)

[Data type] Word axis

[Unit of data]

[Valid data range]

Increment system	Unit of data	Valid data range	
		IS-A, IS-B	IS-C
Millimeter machine	1 mm/min	6 – 15000	6 – 12000
Inch machine	0.1 inch/min	6 – 6000	6 – 4800
Rotation axis	1 deg/min	6 – 15000	6 – 12000

This parameter sets the feedrate difference for each axis in automatic corner deceleration based on the feedrate difference when acceleration/deceleration before interpolation is used. When this parameter is set, the value set in parameter 1780 becomes invalid.

Caution

CAUTION

- 1 Even during dry run or external deceleration, the feedrate difference is checked according to the F command in the program.
- 2 If the G09 (exact stop) command is executed, an exact stop is performed, and Automatic Corner Deceleration is not executed. (M series)
- 3 This function is invalid for the feed per rotation command, F1-digit feed command (M series), and rigid tapping command, as well as in single block mode.
- 4 If the override is changed during operation, the feedrate difference cannot be checked correctly.

Reference item

Series 16i/18i/160i/180i/ 160is/180is	OPERATOR'S MANUAL (For Machining Center) (B-63534EN)	II.5.4.3	Automatic corner deceleration
	OPERATOR'S MANUAL (For Machining Center) (B-63524EN)	II.5.4.3	Automatic corner deceleration

**7.1.13
Advanced Preview
Control**

General

This function is designed for high-speed precise machining. With this function, the delay due to acceleration/deceleration and the delay in the servo system which increase with the feedrate can be suppressed. The tool can then follow specified path accurately and errors in the machining profile can be reduced. This function becomes effective when advanced preview control mode is activated by G08P1 command.

• **Available functions**

In advanced preview control mode, the following functions are available:

- (1) Linear acceleration/deceleration before interpolation for cutting feed
- (2) Automatic corner deceleration function

For details on the above functions, see the descriptions of the functions.

Signal

**advanced preview
control
mode signal
G08MD <F066#0>**

[Classification] Output signal

[Function] Informs that the control is in the advanced preview control mode.

[Output condition] The signal is “1” in the following case:
·In the advanced preview control mode
The signal is “0” in the following case:
·It is not the advanced preview control mode

Signal address

	#7	#6	#5	#4	#3	#2	#1	#0
F066								G08MD

Parameter

1431 Maximum cutting feedrate for all axes in the advanced preview control mode

[Data type] Two-word

[Unit of data]

[Valid data range]

Increment system	Unit of data	Valid data range	
		IS-A, IS-B	IS-C
Millimeter machine	1 mm/min	0 – 240000	0 – 100000
Inch machine	0.1 inch/min	0 – 96000	0 – 48000
Rotation axis	1 deg/min	0 – 240000	0 – 100000

Specify the maximum cutting feedrate for all axes in the advanced preview control mode.

A feedrate in the tangential direction is clamped in cutting feed so that it does not exceed the feedrate specified in this parameter.

WARNING

In a mode other than the advanced preview mode, the maximum cutting feedrate specified in parameter No. 1422 or No. 1430 is applied and the feedrate is clamped at the maximum feedrate.

NOTE

To specify the maximum cutting feedrate for each axis, use parameter No. 1432 instead.

1432 Maximum cutting feedrate for each axis in the advanced preview control mode

[Data type] Two-word axis

[Unit of data]

[Valid data range]

Increment system	Unit of data	Valid data range	
		IS-A, IS-B	IS-C
Millimeter machine	1 mm/min	0 – 240000	0 – 100000
Inch machine	0.1 inch/min	0 – 96000	0 – 48000
Rotation axis	1 deg/min	0 – 240000	0 – 100000

Specify the maximum cutting feedrate for each axis in the advanced preview control mode.

A feedrate for each axis is clamped during cutting feed so that it does not exceed the maximum cutting feedrate specified for each axis.

WARNING

In a mode other than the advanced preview mode, the maximum cutting feedrate specified in parameter No. 1422 or No. 1430 is applied and the feedrate is clamped at the maximum feedrate.

NOTE

- 1 This parameter is effective only in linear and circular interpolation. In polar coordinate, cylindrical, and involute interpolation, the maximum feedrate for all axes specified in parameter No. 1431 is effective.
- 2 If a setting for each axis is 0, the maximum feedrate specified in parameter No. 1431 is applied to all axes and the feedrate is clamped at the maximum feedrate.

	#7	#6	#5	#4	#3	#2	#1	#0
1601						OVB		

[Data type] Bit

OVB Block overlap in cutting feed

- 0: Blocks are not overlapped in cutting feed.
- 1: Blocks are overlapped in cutting feed.

Block overlap outputs the pulses remaining at the end of pulse distribution in a block together with distribution pulses in the next block. This eliminates changes in feedrates between blocks.

Block overlap is enabled when blocks containing G01, G02, or G03 are consecutively specified in G64 mode. If minute blocks, however, are specified consecutively, overlap may not be performed.

NOTE

Be sure to set this bit to 1. (T series)

The following pulses in block F2 are added to the pulses remaining at the end of pulse distribution in block F1.

$$(\text{Number of pulses to be added}) = F2 \times \frac{(\text{Number of pulses required at the end of block F1})}{F1}$$

When F1 = F2

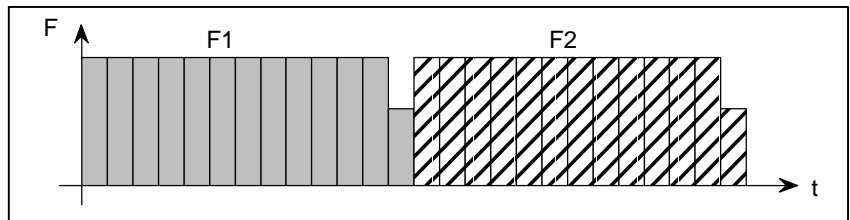

When block overlap is disabled

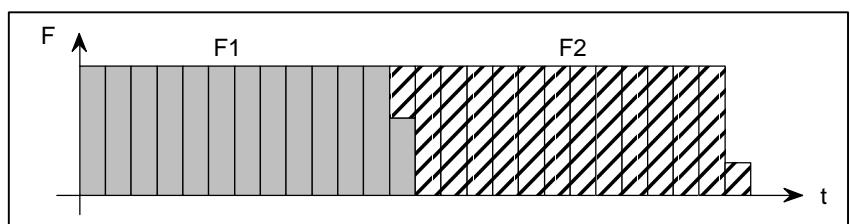

When block overlap is enabled

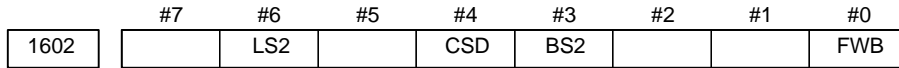

[Data type] Bit

FWB Cutting feed acceleration/deceleration before interpolation

- 0 : Type A of acceleration/deceleration before interpolation is used.
- 1 : Type B of acceleration/deceleration before interpolation is used.

Type A: When a feedrate is to be changed by a command, acceleration/deceleration starts after the program enters the block in which the command is specified.

Type B: When a feedrate is to be changed by a command, deceleration starts and terminates at the block before the block in which the command is specified.

When a feedrate is to be changed by a command, acceleration starts after the program enters the block in which the command is specified.

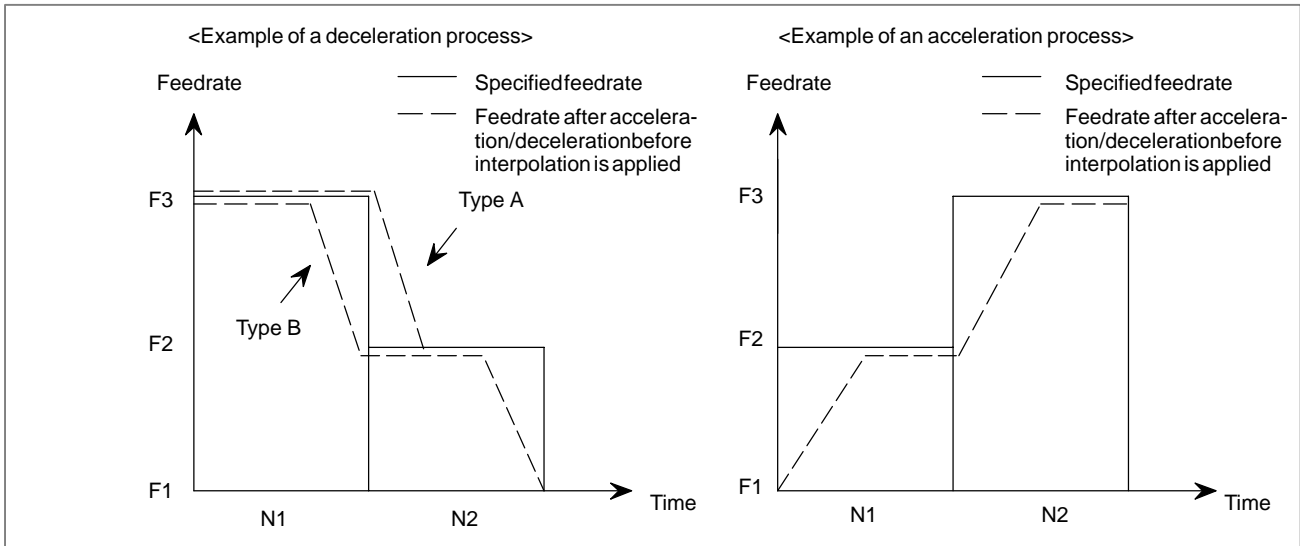

NOTE
Be sure to set this bit to 1.

BS2 Acceleration/deceleration after interpolation for cutting feed in look-ahead control mode/high-precision contour control mode is:

- 0 : Exponential acceleration/deceleration or linear acceleration/deceleration (one of which is selected by the LS2 parameter (bit 6 of parameter No.1602)).
- 1 : Bell-shaped acceleration/deceleration.

BS2	LS2	Acceleration/deceleration
0	0	Exponential acceleration/deceleration after interpolation
0	1	Linear acceleration/deceleration after interpolation. (The option for linear acceleration/deceleration after interpolation for cutting feed is required.)
1	0	Bell-shaped acceleration/deceleration after interpolation. (The option for bell-shaped acceleration/deceleration after interpolation for cutting feed is required.)

CSD In the function for automatically reducing a feedrate at corners,
0 : Angles are used for controlling the feedrate.
1 : Differences in feedrates are used for controlling the feedrate.

LS2 Acceleration/deceleration after interpolation for cutting feed in the advanced preview control mode
0 : Exponential acceleration/deceleration
1 : Linear acceleration/deceleration. (The function for linear acceleration/deceleration after interpolation for cutting feed is required.)

1762	Exponential acceleration/deceleration time constant for cutting feed in the advanced preview control mode
------	---

[Data type] Word axis

[Unit of data] 1 ms

[Valid data range] 0 to 4000

Set an exponential acceleration/deceleration time constant for cutting feed in the advanced preview control mode.

1763	Minimum speed in exponential acceleration/deceleration for cutting feed in the advanced preview control mode
------	--

[Data type] Word axis

[Unit of data]

[Valid data range]

Increment system	Unit of data	Valid data range	
		IS-A, IS-B	IS-C
Millimeter machine	1 mm/min	6 – 15000	6 – 12000
Inch machine	0.1 inch/min	6 – 6000	6 – 4800
Rotation axis	1 deg/min	6 – 15000	6 – 12000

Set a minimum speed (FL) in exponential acceleration/deceleration for cutting feed in the advanced preview control mode.

1768	Time constant for linear acceleration/deceleration or bell-shaped acceleration/deceleration during cutting feed in look-ahead control mode.
------	---

[Data type] Word

[Unit of data] ms

[Valid data range] 8 to 512

This parameter sets a time constant for linear or bell-shaped acceleration/deceleration for cutting feed in the look-ahead control mode. Bits 3 (BS2) and 6 (LS2) of parameter No. 1602 are used to determine which type to use.

NOTE

- 1 For linear acceleration/deceleration, the function of linear acceleration/deceleration after cutting feed interpolation is required.
- 2 For bell-shaped acceleration/deceleration, the function of bell-shaped acceleration/deceleration after cutting feed interpolation is required.

1770

Parameter1 for setting an acceleration for linear acceleration/deceleration before interpolation in the advanced preview control mode (maximum machining speed during linear acceleration/deceleration before interpolation)

[Data type] Two-word

[Unit of data]

[Valid data range]

Increment system	Unit of data	Valid data range	
		IS-A, IS-B	IS-C
Millimeter machine	1 mm/min	6 - 240000	6 - 100000
Inch machine	0.1 inch/min	6 - 96000	6 - 48000

This parameter is used to set an acceleration for linear acceleration/deceleration before interpolation in the advanced preview control mode. In this parameter, set the maximum machining speed during linear acceleration/deceleration before interpolation. Set the time used to reach the maximum machining speed in parameter No. 1771.

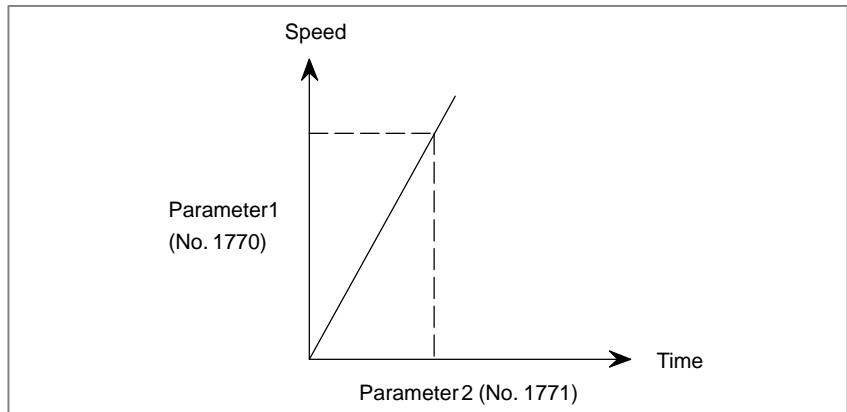

CAUTION

When 0 is set in parameter No. 1770 or parameter No. 1771, linear acceleration/deceleration before interpolation is disabled.

1771	Parameter2 for setting an acceleration for linear acceleration/deceleration before interpolation in the advanced preview control mode (time used to reach the maximum machining speed during linear acceleration/deceleration before interpolation)
------	---

[Data type] Word

[Unit of data] 1 ms

[Valid data range] 0 to 4000

This parameter is used to set an acceleration for linear acceleration/deceleration before interpolation in the advanced preview control mode. In this parameter, set the time (time constant) used to reach the speed set in parameter No. 1770.

CAUTION

- 1 When 0 is set in parameter No. 1770 or parameter No. 1771, linear acceleration/deceleration before interpolation is disabled.
- 2 In parameter Nos. 1770 and 1771, set values that satisfy the following: Parameter No. 1770/Parameter No. 1771 ≥ 5

1777	Minimum speed for the automatic corner deceleration function (for the advanced preview control)
------	---

[Data type] Word

[Unit of data]

[Valid data range]

Increment system	Unit of data	Valid data range	
		IS-A, IS-B	IS-C
Millimeter machine	1 mm/min	6 – 15000	6 – 12000
Inch machine	0.1 inch/min	6 – 6000	6 – 4800

Set a speed at which the number of buffered pulses in deceleration is assumed to be 0 when linear acceleration/deceleration before interpolation is used.

1779	Critical angle subtended by two blocks for automatic corner deceleration (for the advanced preview control)
------	---

[Data type] Two-word

[Unit of data] 0.001 deg

[Valid data range] 0 to 180000

Set a critical angle to be formed by two blocks for corner deceleration when the angle-based automatic corner deceleration function is used. The angle formed by two blocks is defined as θ in the examples shown below.

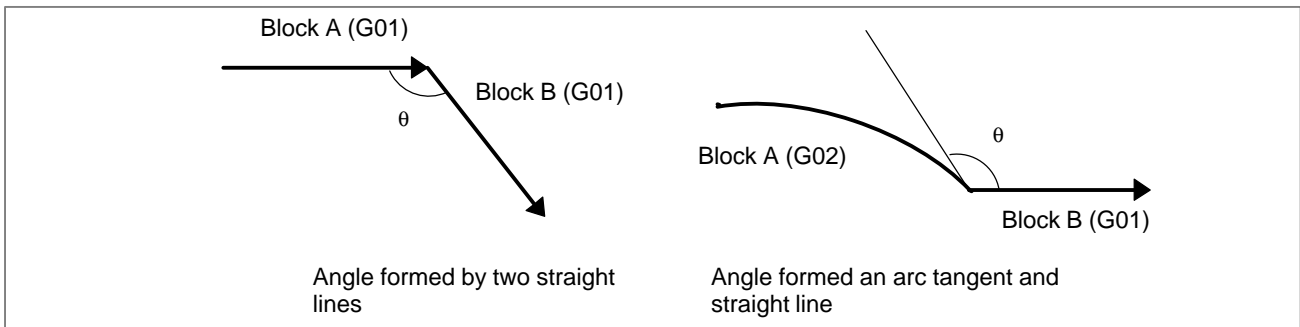

1780

Allowable speed difference for the speed difference based corner deceleration function (for linear acceleration/deceleration before interpolation)

[Data type] Word

[Unit of data]

[Valid data range]

Increment system	Unit of data	Valid data range	
		IS-A, IS-B	IS-C
Millimeter machine	1 mm/min	6 - 15000	6 - 12000
Inch machine	0.1 inch/min	6 - 6000	6 - 4800

Set the speed difference for the speed difference based automatic corner deceleration function when linear acceleration/deceleration before interpolation is used.

1783

Allowable speed difference for the speed difference based corner deceleration function (for linear acceleration /deceleration before interpolation)

[Data type] Word axis

[Unit of data]

[Valid data range]

Increment system	Unit of data	Valid data range	
		IS-A, IS-B	IS-C
Millimeter machine	1 mm/min	6 - 15000	6 - 12000
Inch machine	0.1 inch/min	6 - 6000	6 - 4800
Rotation axis	1 deg/min	6 - 15000	6 - 12000

A separate allowable feedrate difference can be set for each axis. Among the axes that exceed the specified allowable feedrate difference, the axis with the greatest ratio of the actual feedrate difference to the allowable feedrate difference is used as the reference to calculate the reduced feedrate at the corner.

1784

Speed when overtravel alarm is generated during acceleration/deceleration before interpolation

[Data type] Word

[Unit of data]

[Valid data range]

Increment system	Unit of data	Valid data range	
		IS-A, IS-B	IS-C
Millimeter machine	1 mm/min	6 - 15000	6 - 12000
Inch machine	0.1 inch/min	6 - 6000	6 - 4800

Deceleration is started beforehand to reach the feedrate set in the parameter when an overtravel alarm is issued (when a limit is reached) during linear acceleration/deceleration before interpolation. By using this parameter, the overrun distance that occurs when an overtravel alarm is output can be reduced.

WARNING

The control described above is applicable only to stored stroke check 1.

NOTE

- 1 When 0 is set in this parameter, the control described above is not exercised.
- 2 Use type-B linear acceleration/deceleration before interpolation (by setting bit 0 (FWB) of parameter No. 1602 to 1).

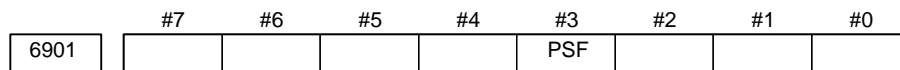

[Data type] Bit

PSF In high-precision contour control mode (M series), AI contour control mode (M series), AI nano-contour control mode (M series), or advanced preview control mode, position switches are:
 0 : Not used.
 1 : Used.

NOTE

- 1 The position switch signals are output considering acceleration/deceleration after interpolation and servo delay. Acceleration/deceleration after interpolation and servo delay are considered even for position switch signal output in a mode other than the high-precision contour control (M series), AI contour control (M series), AI nano contour control (M series), and advanced preview control modes. Note that as a result, the setting of this parameter changes the timing of position switch signal output.
- 2 When using the high-speed position switch of decision-by-direction type, set bit 1 (HPE) of parameter No. 8501 to 0 (to consider a servo delay amount for decision of direction).

**Parameters for advanced
preview control mode
and normal mode****Parameters for the cutting feed acceleration/deceleration before in-
terpolation**

Parameter description	Parameter No.	
	Normal mode	Advanced preview control mode
Acceleration/deceleration type (A type/B type)	FWB (1602#0)	FWB (1602#0)
Acceleration (Parameter 1)	1630	1770
Acceleration (Parameter 2)	1631	1771
Speed when overtravel alarm has gener- ated	1784	1784

Parameters for automatic corner deceleration

Parameter description	Parameter No.	
	Normal mode	Advanced preview control mode
Automatic corner deceleration according to the corner angle or the speed difference	CSD (1602#4)	CSD (1602#4)
Minimum speed (according to the corner angle)	1778	1777
Critical angle (according to the corner angle)	1740	1779
Allowable speed difference for all axes (according to speed difference)	1780	1780
Allowable speed difference for each axis (according to speed difference)	1783	1783

Alarm and message

Number	Message	Description
109	FORMAT ERROR IN G08	A value other than 0 or 1 was specified af- ter P in the G08 code, or no value was spe- cified.

Note**NOTE**

The optional functions usable in the advanced preview control mode are listed below. When using an optional function other than those listed below, turn off the advanced preview control mode before using the function, and turn on the advanced preview control mode upon completion of using the function.

- Inverse time feed (M series)
- High-precision contour control (M series)
- PMC-based axis control (usable in the advanced preview control mode by setting bits 4 (G8R) and 3 (G8C) of parameter No. 8004)
- Single direction positioning (M series)
- Polar coordinate command (M series)
- Helical cutting
- Rigid tapping (usable in the advanced preview control mode by setting bit 5 (G8S) of parameter No. 1602. The serial spindle parameter also needs to be set.)
- Program restart
- External deceleration
- Simple synchronization control
- Sequence number check stop
- Position switch (usable in the advanced preview control mode by setting bit 3 (PSF) of parameter No. 6901)
- Cs contour control (usable in the advanced preview control mode by setting bit 5 (G8S) of parameter No. 1602. The serial spindle parameter also needs to be set.)
- Constant surface speed control
- Spindle speed fluctuation detection
- Spindle synchronization
- Simple spindle synchronization
- Custom macro B
- Optional-angle chamfering/corner rounding (M series)
- Direct drawing dimension input (T series)
- Chamfering/corner rounding (T series)
- Inch/metric switching
- Programmable mirror image (M series)
- Mirror image of facing tool posts (T series)
- Canned cycle (M series)
- Multiple repetitive canned cycle (T series)
- Multiple repetitive canned cycle 2 (T series)
- Hole machining canned cycle (T series)
- Automatic corner override (valid only for changing the inside circular cutting feedrate)
- Scaling (M series)
- Coordinate system rotation
- Three-dimensional coordinate conversion

NOTE

- Workpiece coordinate system
- Figure copy (M series)
- Workpiece coordinate system preset
- Cutter compensation B (M series)
- Cutter compensation C (M series)
- Tool-nose radius compensation (T series)
- Corner arc
- Tool offset (M series)
- Y-axis offset (T series)
- Offset measurement value direct input B (T series)
- Tool life management
- Tool length measurement (M series)
- Graphic display
- Dynamic graphic display (M series)
- Feed per revolution

Reference item

Series 16 <i>i</i> /18 <i>i</i> /160 <i>i</i> /180 <i>i</i> / 160 <i>s</i> /180 <i>s</i>	OPERATOR'S MANUAL (For Machining Center) (B-63534EN)	II.19.6	Advanced preview control (G08)
	OPERATOR'S MANUAL (For Machining Center) (B-63524EN)	II.18.3	Advanced preview control (G08)
Series 21 <i>i</i> /210 <i>i</i> /210 <i>s</i>	OPERATOR'S MANUAL (For Machining Center) (B-63614EN)	II.19.2	Advanced preview control (G08)
Series 20 <i>i</i>	OPERATOR'S MANUAL (For Manual Milling Machine) (B-64204EN)	II.17.1	Advanced preview control (G08)

7.1.14 High-precision Contour Control by RISC (M series)

General

Some machining errors are due to the CNC. Such errors include machining errors caused by acceleration/deceleration after interpolation. To eliminate these errors, the following functions are performed at high speed by an RISC processor. These functions are called high-precision contour control functions.

- Function for multiple-block look-ahead acceleration/deceleration before interpolation. This function eliminates machining errors due to acceleration/deceleration.
- Automatic feedrate control function which enables smooth acceleration/ deceleration by considering changes in the figure and speed and allowable acceleration for the machine. This is performed by reading multiple blocks in advance.

Furthermore, smoother acceleration/deceleration is achieved, enabling the feed-forward factor to be increased. This feature also reduces follow-up error in the servo system.

● Specification table

Name	Function
No. of controlled axes	1 axis to 8 axes
No. of simultaneously controlled axes	Up to max. controlled axes
Axis names	Any of A, B, C, U, V, W, X, Y, Z
Increment system	0.01, 0.001, 0.0001 mm 0.001, 0.0001, 0.00001 inch
Max. programming dimensions	± 8 digits
Positioning	Yes (Available with parameter MSU (No. 8403#1)=1)
Linear interpolation	Yes
Multi-quadrant circular interpolation	Yes
Helical interpolation	Provided (when bit 2 (G02) of parameter No. 8485 is set to 1)
Involute interpolation	Provided (when bit 4 (INV) of parameter No. 8485 is set to 1)
Feed per minute	Yes
Feedrate clamp	Yes
Feedrate override	0 – 254%, Every 1%
2nd feedrate override	0 – 254%, Every 1%
Workpiece coordinate system	Yes (Unchangeable in G05P10000 mode)

Name	Function
Absolute/incremental command	Combined use possible in the block
Sequence number	5 digits
Tape code	EIA, ISO
Tape format	Word address format
Control in/out	Yes
Optional block skip	Yes
Circle radius R specification	Yes
Automatic operation	Memory operation, Tape operation
Method of tape operation	RS-232-C, RS-422, DNC1, and remote buffer
Manual absolute on/off	Yes (FS15 type)
Cycle start, Feed hold	Yes
Dry run	Yes
Feedrate override under dry run	0 – 655.34%, Every 0.01%
Single block	Yes
Inch/metric conversion	Yes (Unchangeable in G05P10000 mode)
Multi-buffer	Yes
Cutter compensation C	Yes
Interlock (all axes)	Yes
Machine lock	Yes
Subprogram call (M98, M198)	Yes (Usable with parameter MSU (No. 8403#1)=1)
Auxiliary function	Yes (Usable with parameter MSU (No. 8403#1)=1)
Scaling	Provided (when bit 0 (G51) of parameter No. 8485 is set to 1)
Coordinate rotation	Provided (when bit 0 (G51) of parameter No. 8485 is set to 1)
Canned drilling cycle	Provided (when bit 1 (G81) of parameter No. 8485 is set to 1)
Rigid tapping	Provided (when bit 1 (G81) of parameter No. 8485 is set to 1)

● **Data that can be specified**

G00 : Positioning (Note)
 G01 : Linear interpolation
 G02 : Circular interpolation, Helical interpolation (CW) (Note)
 G03 : Circular interpolation, Helical interpolation (CCW) (Note)
 G02.2 : Involute interpolation (CW) (Note)
 G03.2 : Involute interpolation (CCW) (Note)
 G17 : Plane selection (XpYp plane)
 where, Xp is the X-axis or its parallel axis;

G18	: Plane selection (ZpXp plane) where, Yp is the Y-axis or its parallel axis;
G19	: Plane selection (YpZp plane) where, Zp is the Z-axis or its parallel axis.
G38	: Cutter compensation C with vector held
G39	: Cutter compensation C corner arc
G40	: Cutter compensation C cancel
G41	: Cutter compensation C, left
G42	: Cutter compensation C, right
G50	: Scaling cancel (Note)
G51	: Scaling command (Note)
G68	: Coordinate rotation command (Note)
G69	: Coordinate rotation cancel (Note)
G73, G74, G76, G80 to G89:	Canned drilling cycle, rigid tapping (Note)
G90	: Absolute command
G91	: Incremental command
Dxxx	: D code
Fxxxx	: F code
Nxxxx	: Sequence number
G05P10000	: Setting the HPCC mode
G05P0	: Canceling the HPCC mode
I, J, K, R	: I, J, K, and R specified for circular interpolation
Axial movement data:	Axial movement data specified with an axis name set in parameter No. 1020 (any of X, Y, Z, U, V, W, A, B, and C)
()	: Control in / out
/n	: Optional block skip
Mxxxx	: Miscellaneous function (Note)
Sxxxx	: Spindle speed function (Note)
Txxxx	: Tool function (Note)
Bxxxx	: Second miscellaneous function (Note)

NOTE

To specify positioning, helical interpolation, involute interpolation, scaling, coordinate rotation, a canned drilling cycle, rigid tapping, a miscellaneous function, a spindle function, a tool function, or a second auxiliary function in high-precision contour control (HPCC) mode, set the corresponding parameter, described in the specification list, to 1. Specifying any of the above functions without setting the corresponding parameter to 1 causes a P/S alarm (No. 5000).

7.1.14.1 Look-ahead acceleration/deceleration before interpolation

When feed per minute is specified, this function reads several tens of blocks ahead to perform acceleration/deceleration before interpolation, that is, to apply acceleration/deceleration to the specified feedrate.

When acceleration/deceleration after interpolation is used, acceleration/deceleration is applied to the interpolated data. Consequently, the interpolated data is changed by acceleration/deceleration. When acceleration/deceleration before interpolation is used, however, acceleration/deceleration is applied to the feedrate data before interpolation. Consequently, the interpolated data is not changed by acceleration/deceleration.

Accordingly, interpolation data ensures that machining follows a specified line or curve at all times, thus eliminating the machining profile errors that result from delays in acceleration/deceleration.

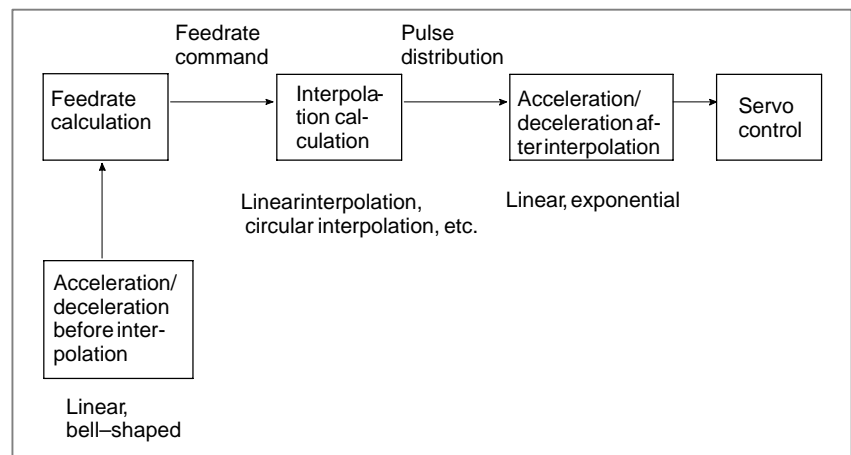

If a feedrate change along any axis is greater than the value set in a parameter for the joint (corner) between two successive blocks, a feedrate is calculated so that the difference in the feedrates does not exceed the specified value. The feedrate is automatically reduced to this calculated value at the corner.

Before this function can be used, specify parameter Nos. 8400 and 8401 for determining an acceleration for acceleration/deceleration before interpolation.

Example of deceleration

To ensure that the feedrate specified for a block is reached when the block is executed, deceleration is started in the previous block.

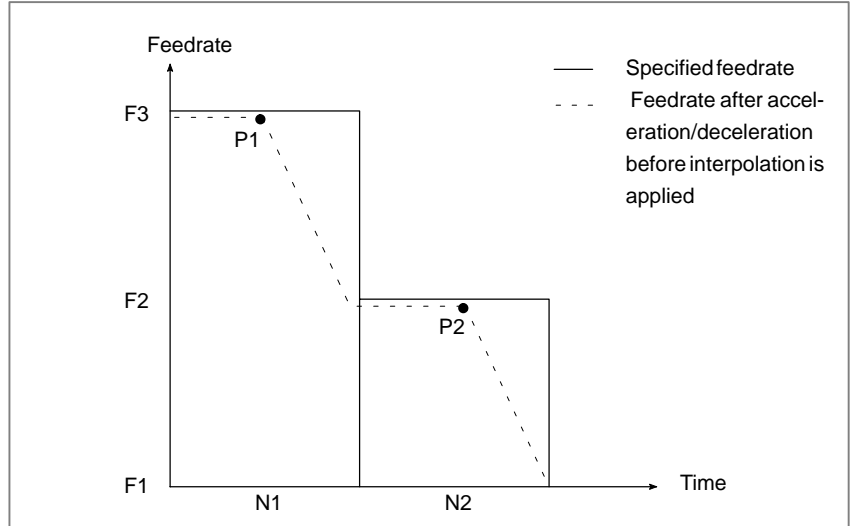

To reduce feedrate F3 to feedrate F2, deceleration must be started at P1. To reduce feedrate F2 to feedrate F1, deceleration must be started at P2.

The tool can be decelerated over several blocks, because several tens of blocks are read in advance.

Example of acceleration

Acceleration is started to reach the specified feedrate for a block when the block is executed.

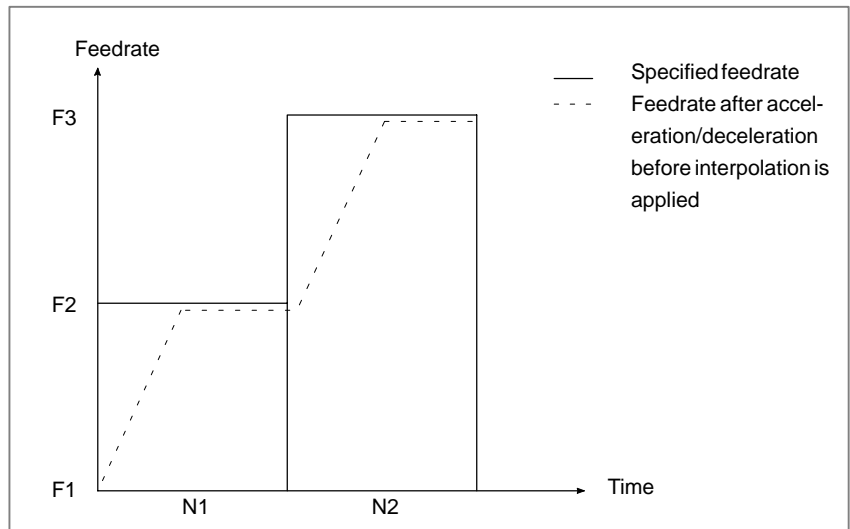

Look-ahead bell-shaped acceleration/deceleration before interpolation

To use this function, set bit 7 (BDO) and bit 1 (NBL) of parameter No. 8402 to 1, and also set the following parameters:

Parameter No. 8400: Parameter 1 for setting the acceleration used for acceleration/deceleration before interpolation

Parameter No. 8401: Parameter 2 for setting the acceleration used for acceleration/deceleration before interpolation

Parameter No. 8402, bit 5 (DST) = 1, bit 4 (BLK) = 0

Parameter No. 8416: Time needed to reach maximum acceleration

For details, see the description of the parameters.

Description

Look-ahead bell-shaped acceleration/deceleration before interpolation controls acceleration as described below.

$$\text{Maximum acceleration ACC_MAX} = \frac{\text{Setting of parameter No. 8400 [mm/min, inch/min]}}{\text{Setting of parameter No. 8401 [ms]}}$$

Time needed to reach maximum acceleration: $\text{ACC_TIME} = \text{Setting in parameter No. 8416 [ms]}$

- When maximum acceleration is reached

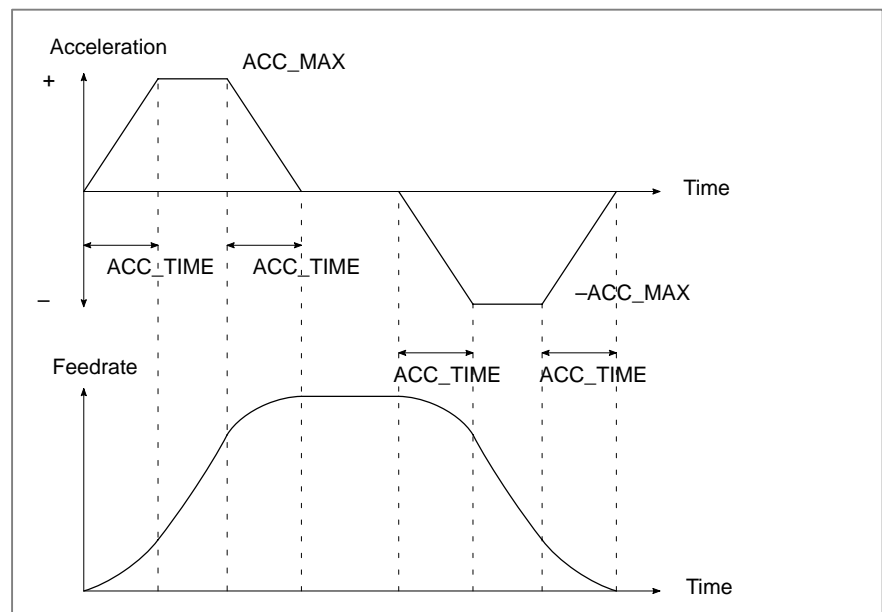

- When maximum acceleration is not reached

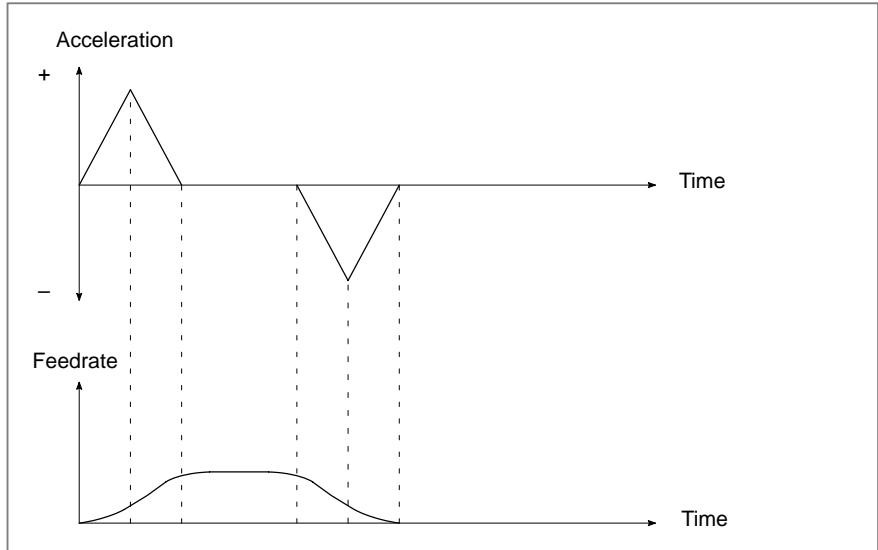

Acceleration

The tool is accelerated to a specified feedrate, starting at the beginning of a block.

The tool can be accelerated over multiple blocks.

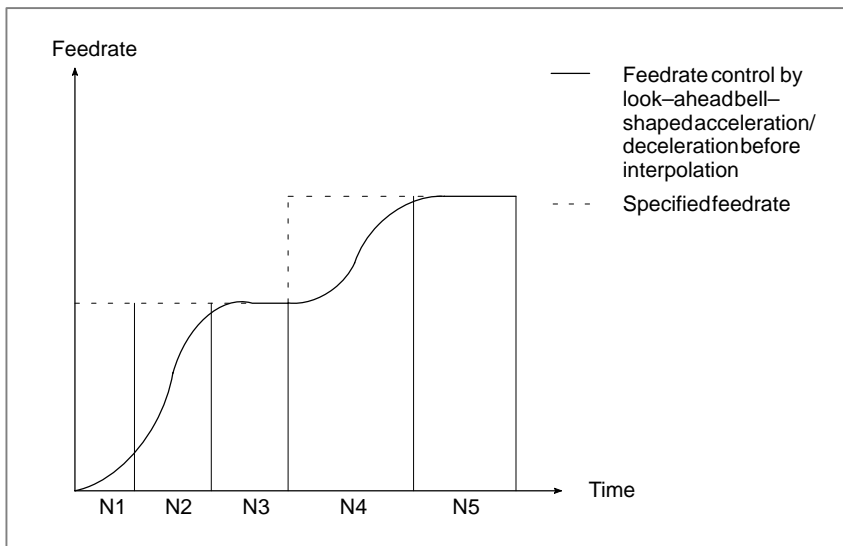

Feedrate clamping based on the total travel of the tool in look-ahead blocks

When the distance required to decelerate the tool from a specified feedrate is less than the total travel of the tool in the blocks read in advance, the feedrate is automatically clamped to a feedrate from which the tool can be decelerated to a feedrate of zero.

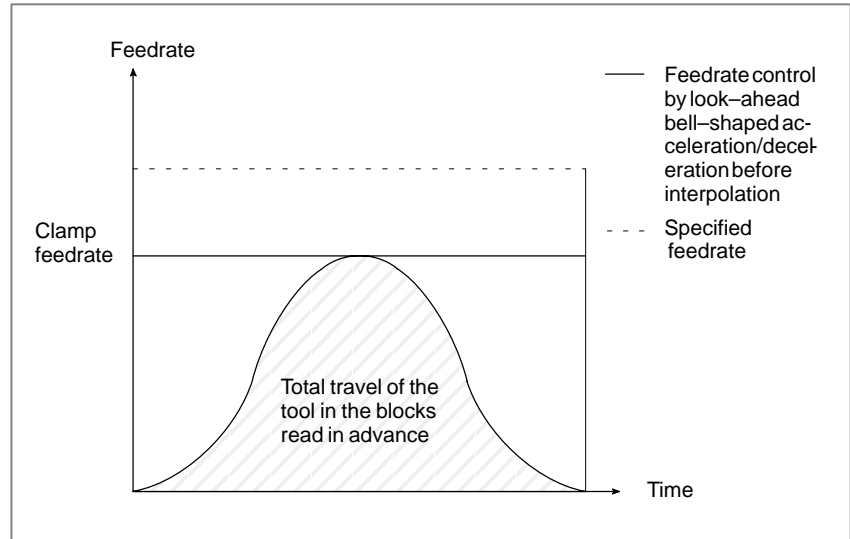

When several blocks, each specifying a short travel, are specified in succession, the following situation can occur:

The total travel of the tool in the blocks read in advance at the start of acceleration is less than the distance required to decelerate the tool from a specified feedrate, but the total travel of the tool in the blocks read in advance at the end of acceleration is greater than the distance required to decelerate the tool from a specified feedrate.

In such a case, the tool is accelerated once and clamped to the feedrate obtained based on the total travel of the tool in the blocks read in advance. Then, the tool is accelerated to a specified target feedrate.

- At the start of acceleration

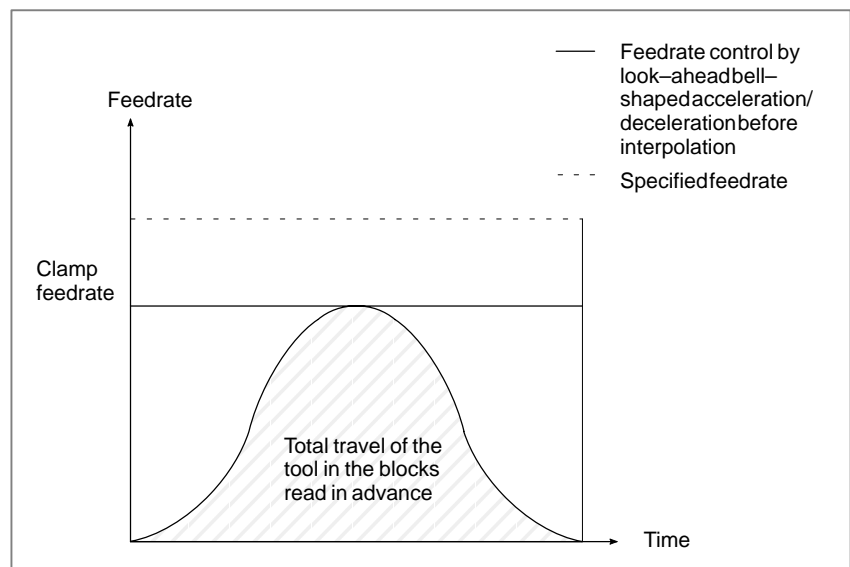

- At the end of acceleration

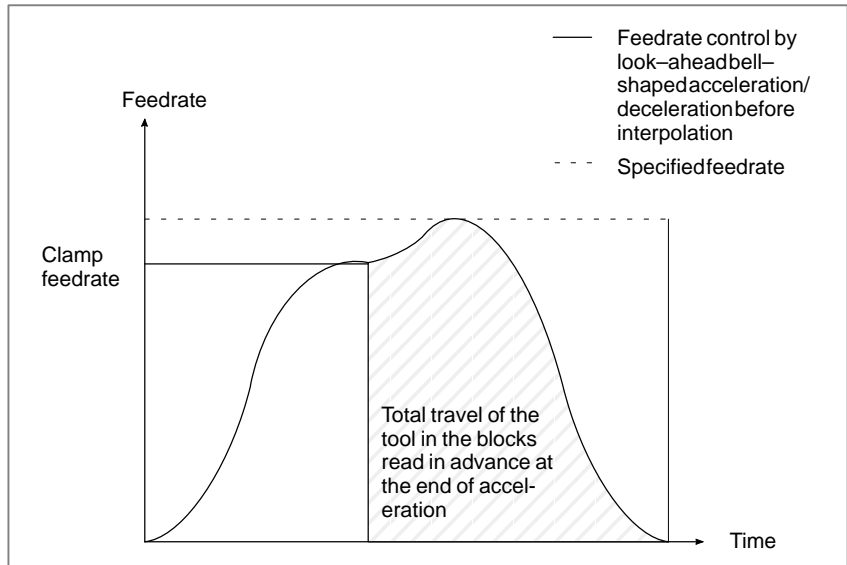

Feedrate command and feedrate

If an F command is changed by, for example, another F command, the corner deceleration function, or the automatic feedrate determination function, look-ahead bell-shaped acceleration/deceleration before interpolation treats the changed feedrate as a new target feedrate, and restarts acceleration/deceleration.

Whenever an F command is changed, bell-shaped acceleration/deceleration is performed.

Bell-shaped acceleration/deceleration is performed each time a different feedrate command is specified, for example, in a program containing successive blocks, each specifying a short travel.

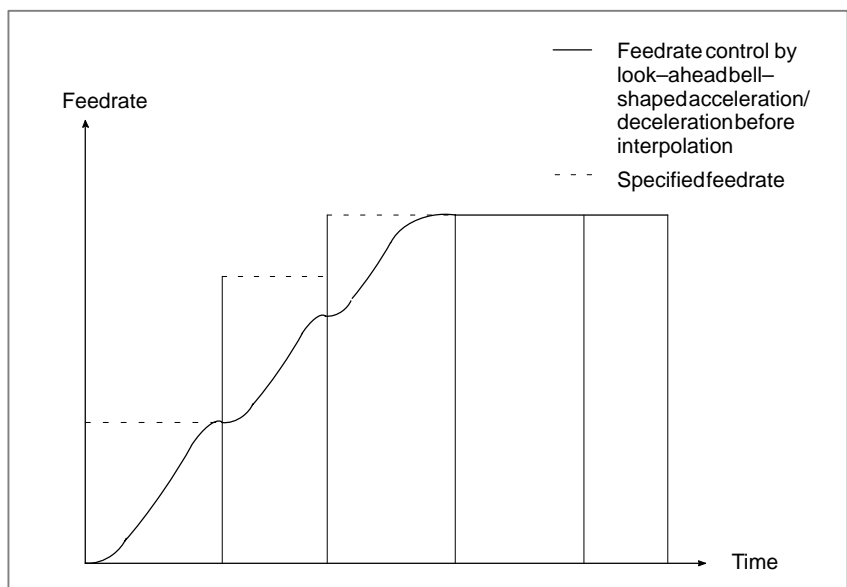

When the feed hold function is used during acceleration

When the feed hold function is used during acceleration, control is performed as described below.

- While applying constant or increasing acceleration

Starting at the point where the feed hold function is specified, the acceleration is gradually reduced to 0. Then, the feedrate for the tool is gradually reduced to 0. Thus, the feed hold function does not always immediately reduce the feedrate of the tool; it instead may sometimes increase the feedrate for a brief instant before reducing the feedrate.
- While applying decreasing acceleration

First, the acceleration is gradually reduced to 0. Then, the feedrate is gradually reduced to 0.

Deceleration

The tool is decelerated to the feedrate specified for a block, starting at the previous block.

The tool can be decelerated over multiple blocks.

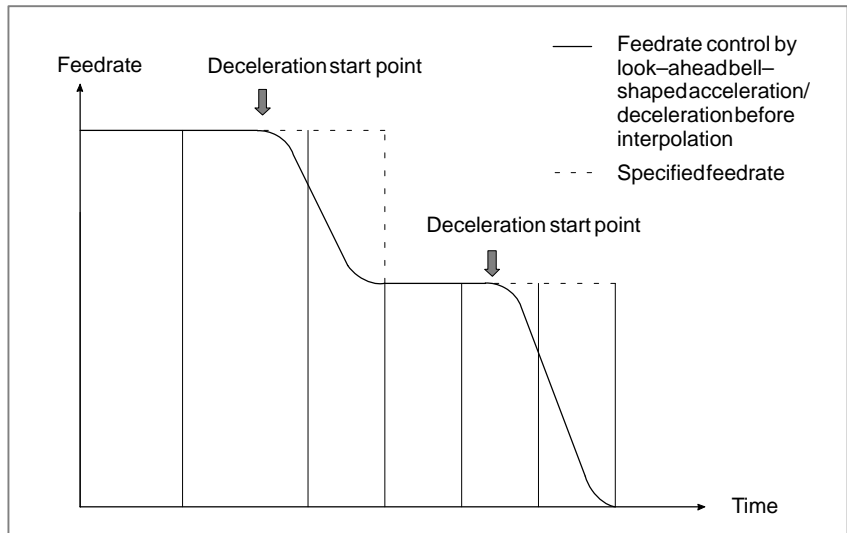

Feedrate command and deceleration

If an F command is changed by, for example, another F command, the corner deceleration function, or the automatic feedrate determination function, look-ahead bell-shaped acceleration/deceleration before interpolation treats the changed feedrate as a new target feedrate, and restarts acceleration/deceleration.

Whenever an F command is changed, bell-shaped acceleration/deceleration is performed.

When the distance required to decelerate the tool from a specified feedrate is longer than the total travel of the tool in the blocks read in advance, the feedrate is automatically clamped, as in the case of acceleration.

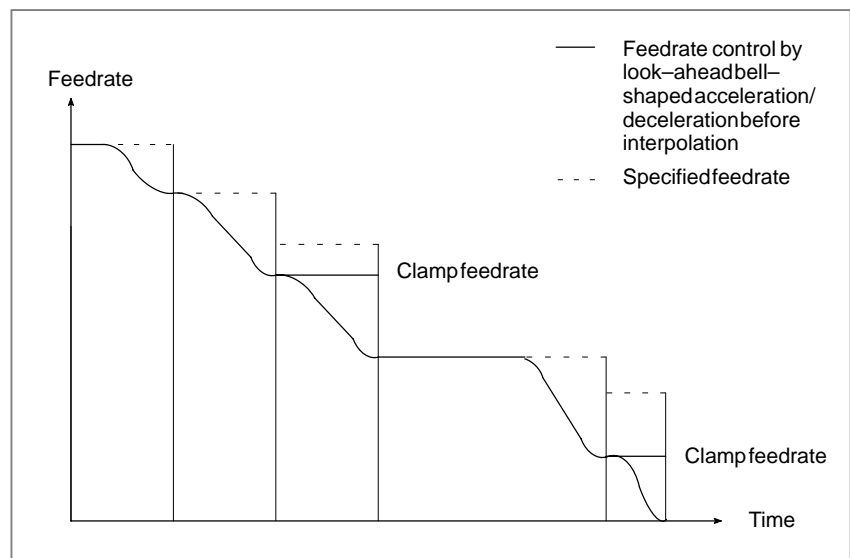

Deceleration based on tool travel

The deceleration of the tool is started when the total travel of the tool in the blocks read in advance is less than the distance required to decelerate the tool from the current feedrate.

When the total travel of the tool in the blocks read in advance increases at the end of deceleration, the tool is accelerated.

When blocks specifying a short travel are specified in succession, the tool may be decelerated, then accelerated, then decelerated, and so on, resulting in an unstable feedrate. In such a situation, specify a smaller feedrate.

Feed hold during deceleration

When the feed hold function is used during deceleration, control is performed as described below.

- While applying constant or increasing deceleration
The point where the deceleration starts being reduced to 0 is shifted from the usually used point (i.e., that used when feed hold is not applied) to ensure that the feedrate for the tool is gradually reduced to 0.
- While applying decreasing deceleration
First, the deceleration is gradually reduced to 0. Then, the feedrate is reduced to 0.

Single block function while look-ahead bell-shaped acceleration/deceleration before interpolation is used

When the single block function is specified while look-ahead bell-shaped acceleration/deceleration before interpolation is used, control is performed as described below.

While the tool is being accelerated or decelerated when the single block function is specified

(1) $A + B \leq$ Remaining travel for the tool in the block being executed when the single block function is specified

The tool is gradually decelerated so that the feedrate is 0 upon completion of the execution of the block that was being executed when the single block function was specified.

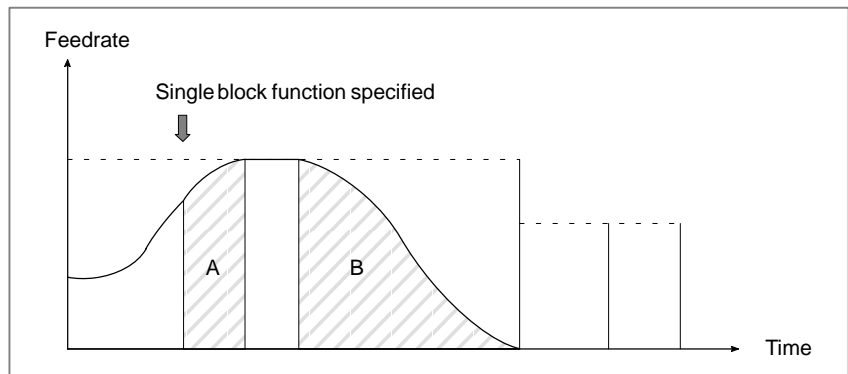

A: Distance traveled before the tool reaches the specified feedrate from the current acceleration/deceleration

B: Distance traveled before the feedrate falls to 0 from a feedrate to which no acceleration/deceleration is applied

(2) $A + B >$ Remaining travel for the tool in the block being executed when the single block function is specified

The tool may be decelerated over multiple blocks until it stops.

How the tool is stopped is described later.

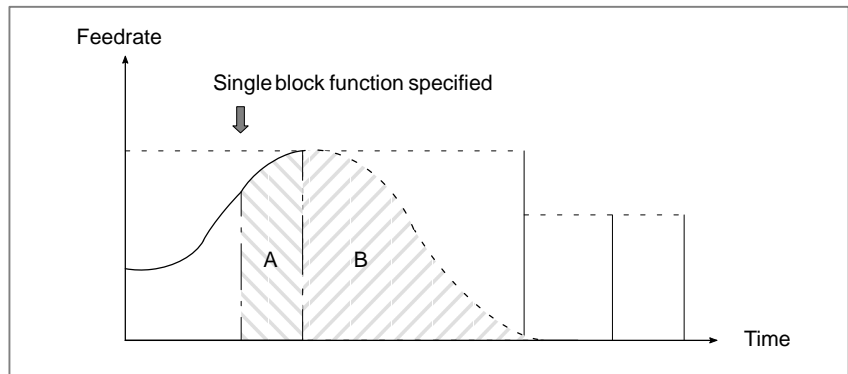

A: Distance traveled before the tool reaches the specified feedrate with the current acceleration/deceleration

B: Distance traveled until the feedrate falls to 0 from a feedrate to which no acceleration/deceleration is applied

While the tool is not being accelerated or decelerated when the single block function is specified

- (1) $A \leq$ Remaining travel for the tool in the block being executed when the single block function is specified

The tool is gradually decelerated so that the feedrate is 0 upon completion of the execution of the block that was being executed when the single block function was specified.

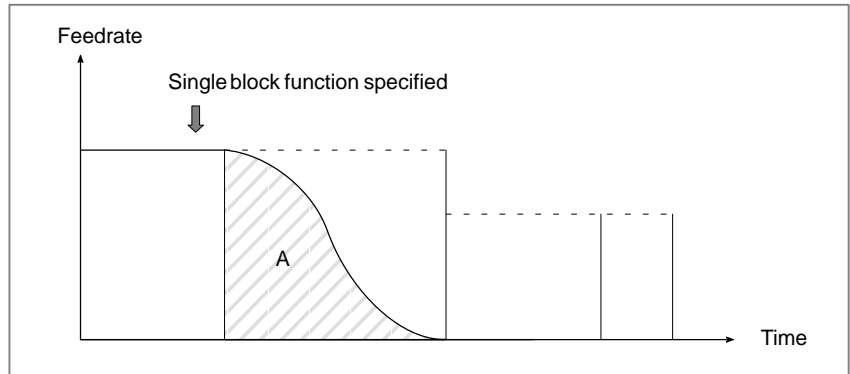

A: Distance traveled until the feedrate falls from the current feedrate value to 0

- (2) $A >$ Remaining travel of the tool in the block being executed when the single block function is specified

The tool may be decelerated over multiple blocks until it stops. How the tool is stopped is described later.

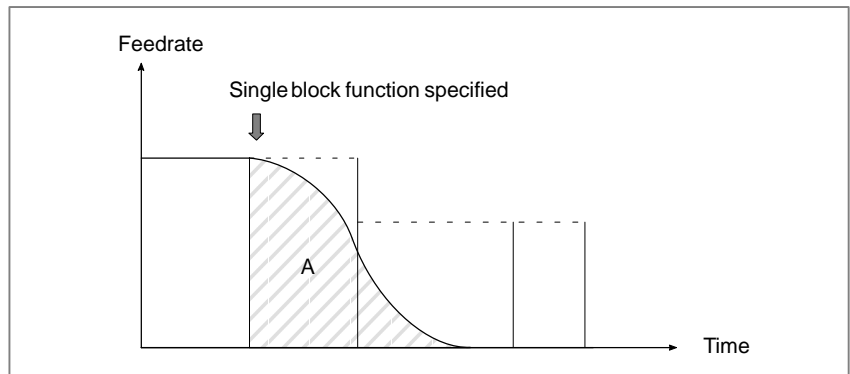

A: Distance traveled until the feedrate falls from the current feedrate value to 0

How the tool is stopped when decelerated over multiple blocks

The tool is decelerated (or accelerated) over multiple blocks until the feedrate becomes 0.

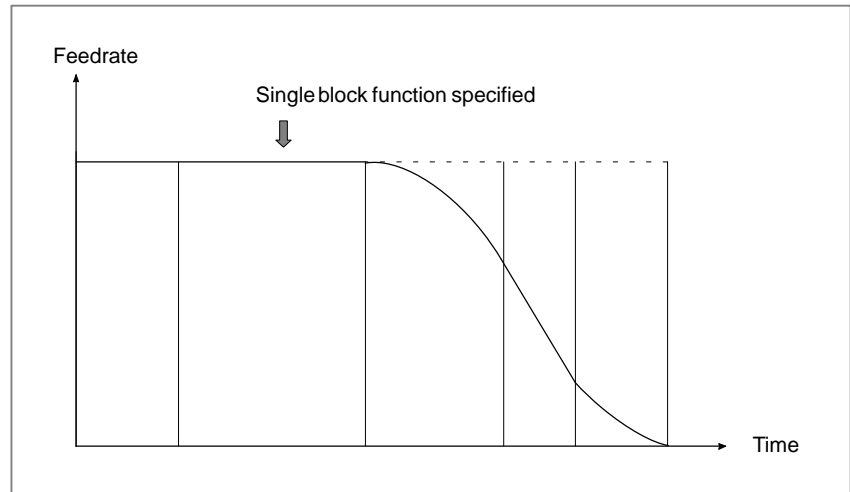

CAUTION

- 1 Depending on the stop point and remaining blocks, two or more acceleration/deceleration operations may be performed.
- 2 When the single block function is specified, an acceleration/deceleration curve recalculation is required while the tool is moving along an axis. So, the tool is not always decelerated over the minimum number of blocks before stopping.

Dryrun/feedrateoverride

When a change in the specification of the dry run function or feedrate override function results in a change in the specified feedrate (feedrate change due to an external cause) while look-ahead bell-shaped acceleration/deceleration before interpolation is being used, control is performed as described below.

While the tool is being accelerated or decelerated when the specification of the dry run function or feedrate override function is changed

After the current acceleration/deceleration operation brings the tool to a specified feedrate and is terminated, the tool is then accelerated or decelerated to the new target feedrate.

While the tool is not being accelerated or decelerated when the specification of the dry run function or feedrate override function is changed

The tool is accelerated or decelerated from the current feedrate to the specified feedrate.

Caution

CAUTION

- 1 When the specification of the dry run function or feedrate override function is changed, the acceleration/deceleration curve must be recalculated while the tool is actually moving along an axis. For this reason, there will be a slight delay before a feedrate change is actually started after the specification of the dry run function or feedrate override function is changed.
- 2 When the specification of the dry run function or feedrate override function is changed, the tool may be decelerated to below a specified feedrate and then accelerated, depending on the remaining amount of travel, current feedrate, and target feedrate.

**Bell-shaped
acceleration/deceleration
of constant
acceleration/deceleration
change time type**

Look-ahead bell-shaped acceleration/deceleration before interpolation (bell-shaped acceleration/deceleration of constant acceleration/deceleration change time type) has the features described below. (When a feedrate change is made by a feedrate command (F command), the corner deceleration function, or automatic feedrate determination, for example, conventional look-ahead bell-shaped acceleration/deceleration before interpolation treats the new feedrate as a target feedrate and performs bell-shaped acceleration/deceleration each time the feedrate is changed, to end up acceleration/deceleration. If there is no more look-ahead block, deceleration is performed until the feedrate reaches 0.)

- (1) When the block does not allow a sufficient distance for acceleration/deceleration to a determined feedrate, the bell-shaped acceleration/deceleration is not performed.

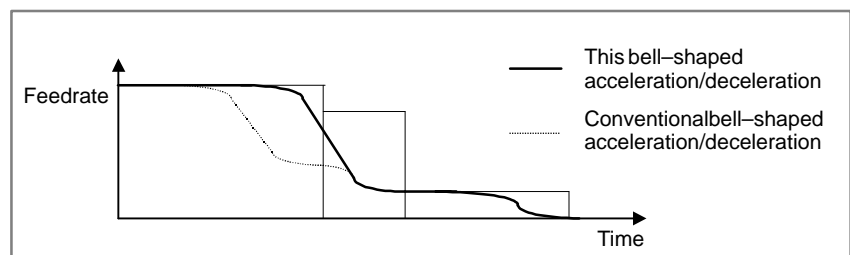

- (2) When there is no more look-ahead block, deceleration is performed. However, when look-ahead blocks become available in the middle, acceleration is started at that time.

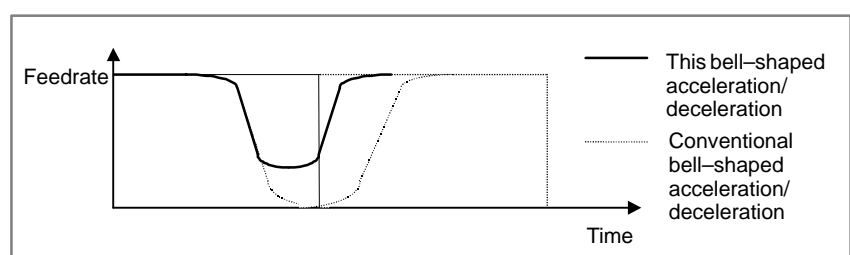

- (3) The acceleration/deceleration change time is constant. If deceleration becomes necessary during acceleration, an acceleration/deceleration change occurs for the constant time specified in parameter No. 8416. This means that the acceleration/deceleration change rate is no longer constant. (With conventional look-ahead bell-shaped acceleration/deceleration before interpolation, the acceleration/deceleration change rate is constant.)

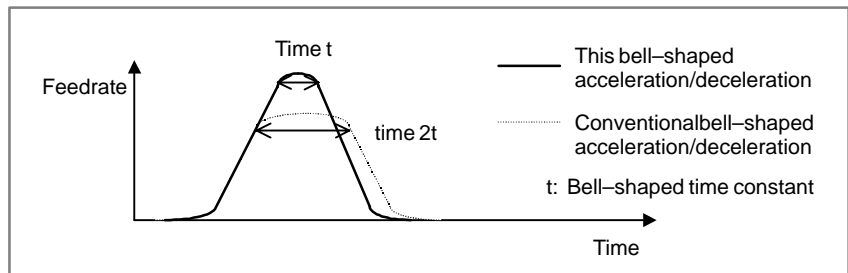

To distinguish between conventional look-ahead bell-shaped acceleration/deceleration before interpolation and this look-ahead bell-shaped acceleration/deceleration before interpolation, the former is referred to as bell-shaped acceleration/deceleration with constant acceleration/deceleration rate type, and the latter is referred to as bell-shaped acceleration/deceleration of constant acceleration/deceleration change time type.

To enable look-ahead bell-shaped acceleration/deceleration before interpolation (of constant acceleration/deceleration change time type), set the parameter as follows:

Bit 3 (SBL) of parameter No. 1603 to 1

For a bell-shaped time constant, parameter No. 8416 as used for the conventional bell-shaped time constant can be used. However, the valid data range is extended to 400 ms.

7.1.14.2 Automatic feedrate control function

This function reads several tens of blocks ahead to exercise automatic feedrate control.

A feedrate is determined on the basis of the conditions listed below. If a specified feedrate exceeds a calculated feedrate, acceleration/deceleration before interpolation is used so that the calculated feedrate can be established.

- (1) Feedrate change and specified allowable feedrate difference along each axis at a corner
- (2) Anticipated acceleration and specified allowable acceleration along each axis
- (3) Cutting load change anticipated from the direction of motion along the Z-axis

In automatic feedrate control mode, the feedrate is automatically reduced with acceleration/deceleration before interpolation to minimize the stress and strain applied to the machine.

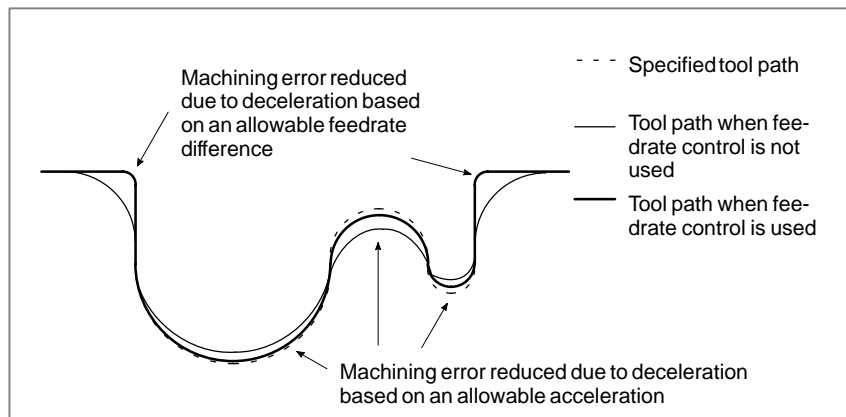

To use this function, set bit 0 (USE) of parameter No. 8451 to 1, and set the following parameters:

- Parameter No. 8410: Allowable feedrate difference used for feedrate determination, based on a corner feedrate difference
- Parameter No. 8475, bit 2 (BIP) = 1: Enables deceleration at a corner.
- Parameter No. 8470: Parameter specifying an allowable acceleration for feedrate determination, based on acceleration
- Parameter No. 8459, bit 1 (CTY) = 1, bit 0 (CDC) = 0
- Parameter No. 8464: Initial feedrate for automatic feedrate control
- Parameter No. 8465: Maximum allowable feedrate for automatic feedrate control

For details, see the description of each parameter.

Feedrate control conditions

In automatic feedrate control mode, the feedrate for the tool is controlled as described below.

- The feedrate required at a corner is calculated from the specified feedrate difference at the corner along each axis, the tool being decelerated to the calculated feedrate at the corner.

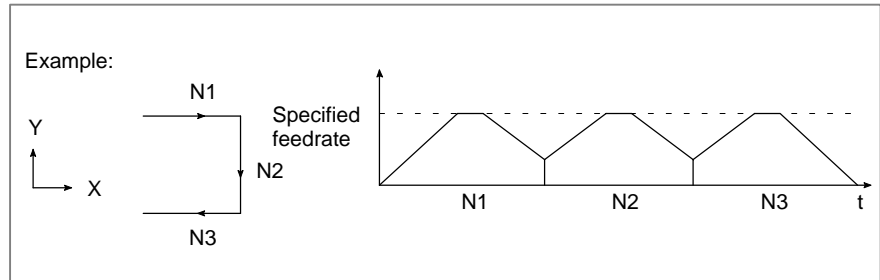

- The feedrate required in a block is calculated from the specified acceleration along each axis at the start point and end point of the corner, the tool being decelerated so that the feedrate in the block does not exceed the calculated feedrate.

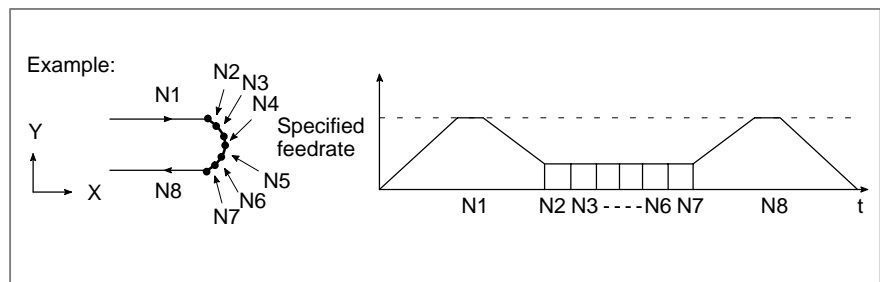

- The feedrate required in a block is calculated from the angle of downward movement along the Z-axis, the tool being decelerated so that the feedrate in the block does not exceed the calculated feedrate.

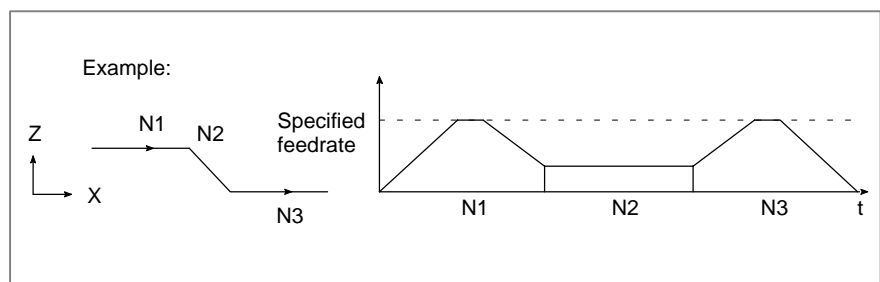

Example of feedrate determination based on a feedrate difference along each axis

The feedrate required at a corner is calculated from the feedrate difference along each axis, as described below.

When the tool is to move at the specified feedrate F, a comparison is made between the feedrate change along each axis (Vc[X], Vc[Y], ...) and the value (Vmax) set in parameter No. 8410. If Vmax is exceeded by a feedrate change along any axis, the tool is decelerated at the corner to the required feedrate Fc:

$$F_c = F \times \frac{1}{R_{max}}$$

where Rmax is the largest value of $R = \frac{V_c}{V_{max}}$

Suppose that the specified feedrate for the tool is 1,000 mm/min, and that the direction of tool movement changes by 90 degrees (from along the X-axis to along the Y-axis). Suppose also that an allowable feedrate difference of 500 mm/min is set. Then, the tool will decelerate as shown below.

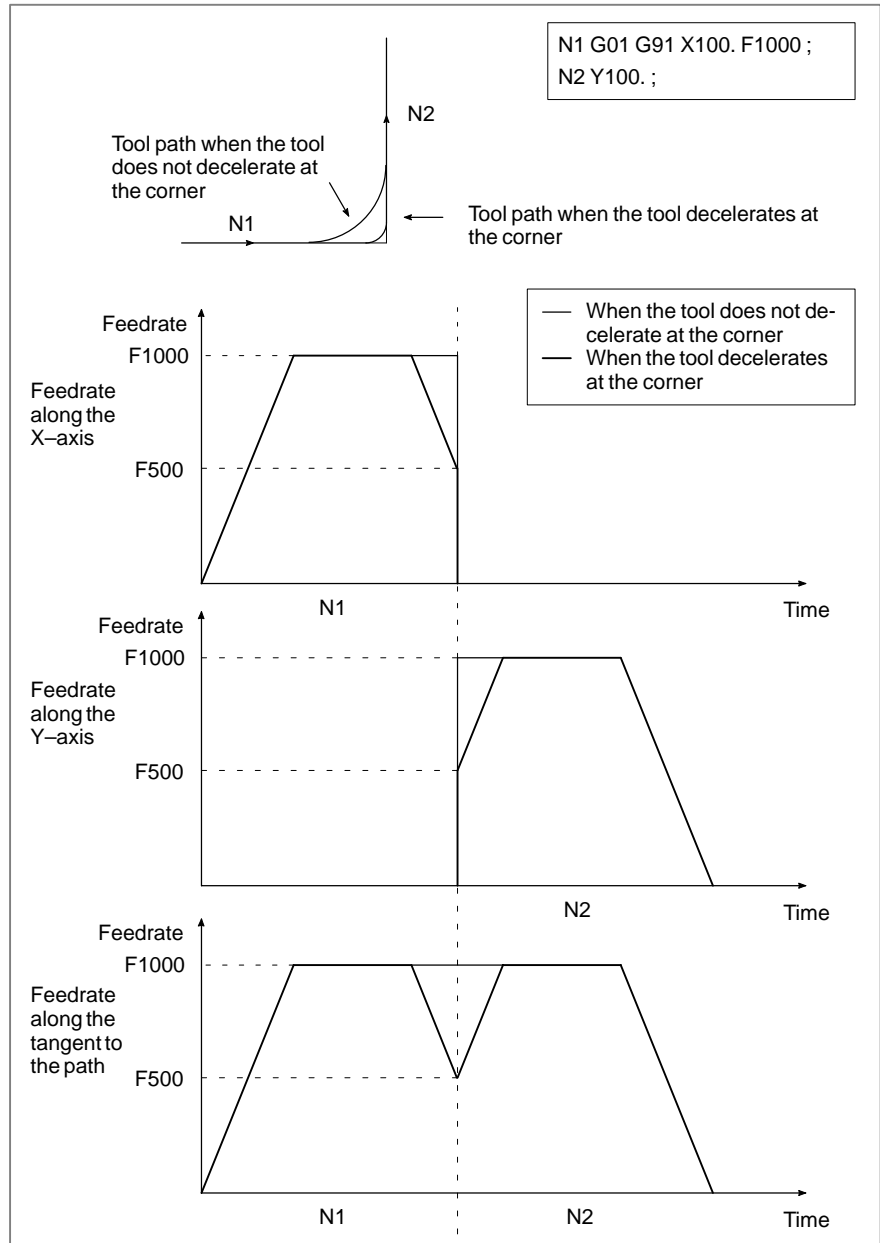

Example of feedrate determination based on acceleration along each axis

As shown below, when a curve is formed by very short successive line segments, there is no significant feedrate difference along each axis at each corner. Consequently, the tool need not be decelerated to compensate for feedrate differences. When taken as a whole, however, successive feedrate differences generate a large acceleration along each axis.

In this case, the tool must be decelerated to minimize the stress and strain imposed on the machine, as well as the machining error that may result from such excessive acceleration. The tool is decelerated to the feedrate at which the acceleration along each axis, found from the formula below, is equal to or less than a specified allowable acceleration.

The allowable acceleration is determined from a maximum cutting feedrate (set in parameter No. 1432, No. 1430, or No. 1422) and the time needed to reach the maximum cutting feedrate (set in parameter No. 8470).

Acceleration along each axis =

$$\frac{\text{Feedrate difference along each axis at a corner}}{\max \left(\frac{\text{Travel in the previous block}}{F}, \frac{\text{Travel in the next block}}{F} \right)}$$

The reduced feedrate required for each corner is calculated. The tool is decelerated to the decreased feedrate found at either the start point or the end point of each block, whichever is smaller.

Example: In the example shown below, the tool is accelerated too quickly from N2 to N4 and from N6 to N8 (as indicated by the dashed-line inclinations in the feedrate graphs) when automatic feedrate control is not used. So, the tool is decelerated.

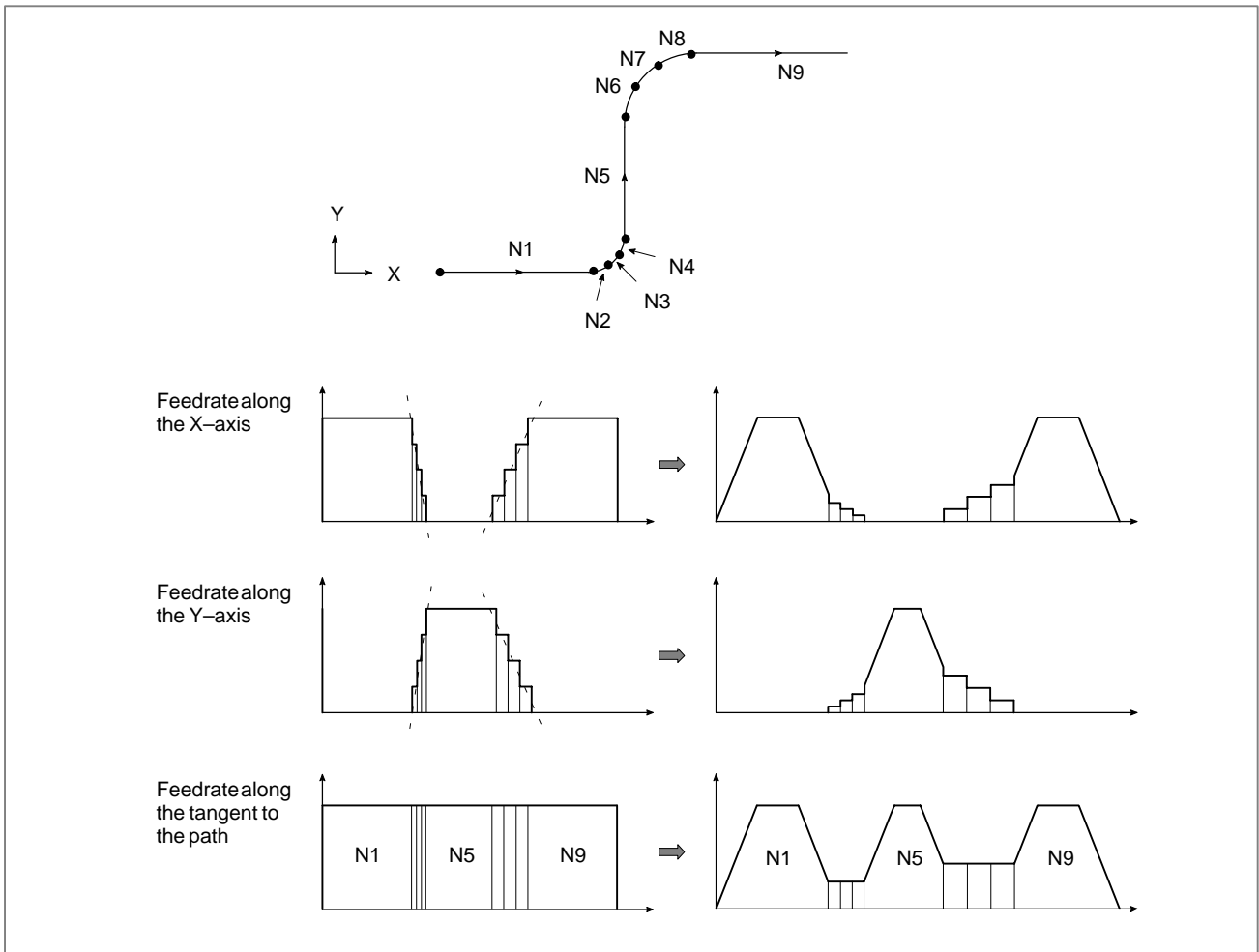

Feedrate determination based on an allowable acceleration during circular interpolation

When a block specifies circular feed per minute and bit 3 (CIR) of parameter No. 8475 is set to 1, the feedrate of the tool is automatically determined so that the acceleration along each axis does not exceed an allowable acceleration.

The allowable acceleration is determined from the maximum cutting feedrate (set in parameter No. 1432, No. 1430, or No. 1422) and the time needed to reach the maximum cutting feedrate (set in parameter No. 8470).

During circular interpolation, the tool is controlled so that it always moves along the path at the specified feedrate. At this time, the total acceleration of the tool, consisting of the acceleration along each axis, is calculated as follows:

$$\text{Acceleration} = \frac{F^2}{R}$$

F: Feedrate
R: Arc radius

A feedrate is calculated, as shown below, so that the total acceleration does not exceed the smaller of the allowable accelerations along the two axes of circular interpolation. If a specified feedrate is greater than the calculated feedrate, the tool is decelerated to the calculated feedrate.

$$\frac{F^2}{R} = \min(\alpha_x, \alpha_y)$$

$$F = \sqrt{R \times \min(\alpha_x, \alpha_y)}$$

α_x, α_y : Allowable accelerations along X-axis and Y-axis

**Example of feedrate
determination based on
cutting load**

This function can be used when bit 4 (ZAG) of parameter No. 8451 is set to 1.

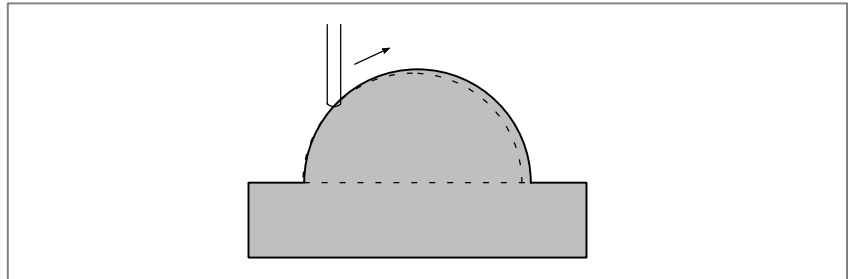

Fig. 7.1.14.2 (a) When the tool is moving up along the Z-axis

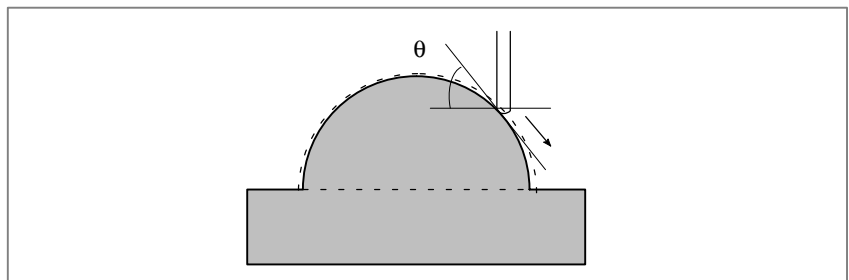

Fig. 7.1.14.2 (b) When the tool is moving down along the Z-axis

Cutting the workpiece with the end of the cutter (Fig. 7.1.14.2 (b)) incurs a greater resistance than when cutting the workpiece with the side of the cutter (Fig. 7.1.14.2 (a)). Therefore, for (Fig. 7.1.14.2 (b)), the tool must be decelerated. To calculate the required degree of feedrate deceleration, the automatic feedrate control function uses the angle of downward movement of the tool along the Z-axis.

When the tool is moving down along the Z-axis, the angle (θ) of downward movement formed by the XY plane and cutter path is as shown in the Fig. 7.1.14.2 (b). The angle of downward movement is divided into four areas, with an override value for each area specified in a parameter, as follows:

Area 2: Parameter No. 8456

Area 3: Parameter No. 8457

Area 4: Parameter No. 8458

No override parameter is provided for area 1; the override value for area 1 is always 100%. A feedrate determined with a separate feedrate control function is multiplied by the override value specified for the area to which the angle θ of downward movement belongs.

Area 1: $0^\circ \leq \theta < 30^\circ$

Area 2: $30^\circ \leq \theta < 45^\circ$

Area 3: $45^\circ \leq \theta < 60^\circ$

Area 4: $60^\circ \leq \theta \leq 90^\circ$

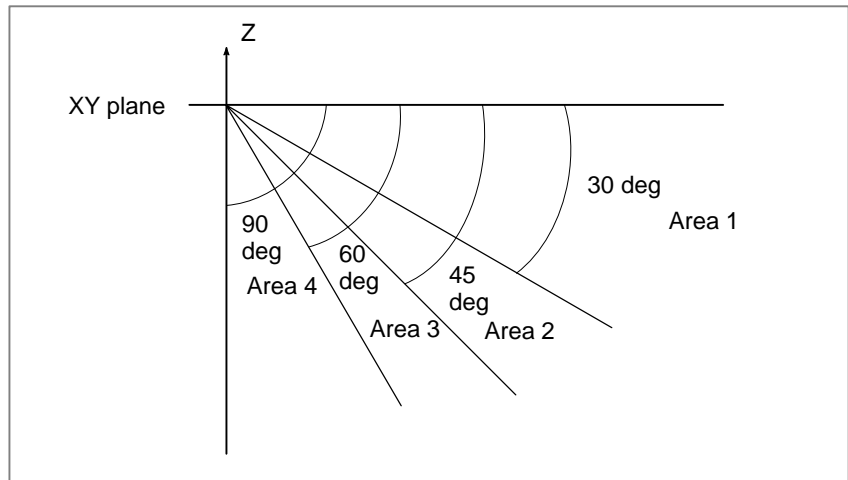
**CAUTION**

The feedrate determination function that is based on cutting load uses an NC command to determine the direction of movement along the Z-axis. This means that the direction of movement along the Z-axis cannot be found if the movement along the Z-axis is subject to manual intervention with manual absolute on/off function set to on, or if the mirror image function is used with the Z-axis. So, never use these functions when using feedrate determination based on cutting load.

Ignoring F code commands

In a block for which the automatic feedrate control function is enabled, the ignoring of all feed commands (F commands) can be specified by setting bit 7 (NOF) of parameter No. 8451. The feed commands are:

- (1) Modal F command specified before a block for which the automatic feedrate control function is enabled
- (2) Modal F command and F command specified in a block for which the automatic feedrate control function is enabled

Note, however, that specified F commands and modal F commands are stored in the CNC.

This means that in a block for which the automatic feedrate control function is disabled, a modal F command of (1) or (2) is used instead of a modal F command calculated by the automatic feedrate control function.

Other examples of feedrate determination conditions

If a calculated feedrate exceeds the maximum allowable feedrate for automatic feedrate control, specified in parameter No. 8465 or with an F command, the feedrate is clamped to the maximum allowable feedrate or F command, whichever is smaller.

Automatic speed control in involute interpolation

Involute interpolation automatic speed control overrides a specified feedrate automatically, in the following two ways, during involute interpolation to obtain a high-quality surface with improved machining precision.

- Override with cutter compensation inside offset
- Override near the basic circle

(1) Override with cutter compensation inside offset

In standard involute interpolation mode, when cutter compensation is applied to involute interpolation, control is provided so that the speed in the direction tangential to the path of the tool center (tool center path) is always set to a specified feedrate.

In this case, the actual cutting speed, which is the speed of the tool periphery point (cutting point) on the programmed path, varies because the curvature of the involute curve is constantly changing.

In particular, when the tool offset is inside the involute curve, as the tool approaches the basic circle, the actual cutting speed increases relative to a specified feedrate.

For smooth machining, the actual cutting speed should be controlled to match a specified feedrate. This function calculates an override according to the curvature of the involute curve which changes from moment to moment during involute interpolation, especially when an inside offset is used. Then, the function controls the actual cutting speed which is the speed in the direction tangential to the curve at the cutting point, so that the actual cutting speed always matches a specified feedrate.

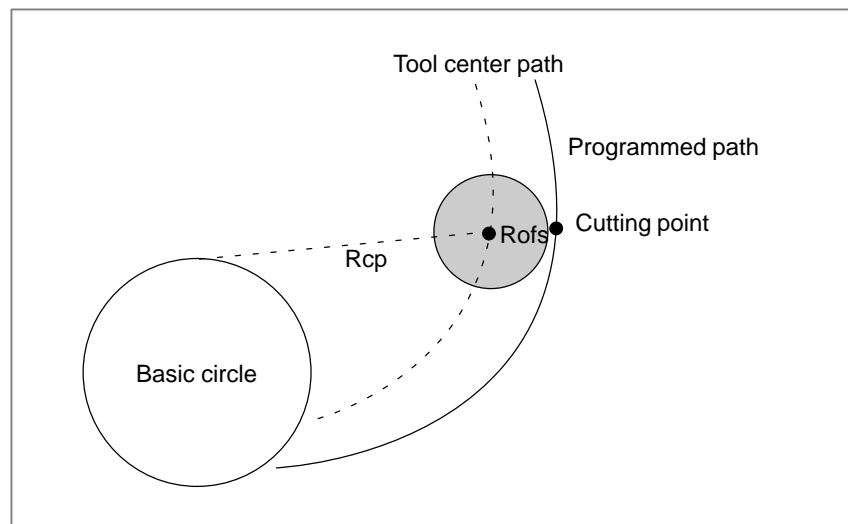

The override value is calculated as follows:

$$\text{OVRa} = \frac{R_{cp}}{R_{cp} + R_{ofs}} \times 100$$

R_{cp} : Radius of curvature at the tool center on the involute curve that passes through the tool center

R_{ofs} : Tool radius

(2) Override near the basic circle

Near the basic circuit, the change in curvature of an involute curve is relatively large. If such areas are cut at a programmed feedrate, a heavy load may be placed on the cutter, preventing a smooth surface from being produced.

When areas near the basic circuit where the change in curvature of an involute curve is relatively large are cut, this function can reduce the load on the cutter, thus enabling a smooth surface to be obtained by automatically decelerating the tool movement according to the parameter setting.

When the radius of curvature at the cutting point is in the range specified by parameters (Rlmt1) to (Rlmt5), an override is applied as follows:

When $Rlmt1 > Rcp \pm Rofs \geq Rlmt2$

$$OVRb = \frac{100 - OVR2}{Rlmt1 - Rlmt2} \times (Rcp \pm Rofs - Rlmt2) + OVR2$$

When $Rlmt2 > Rcp \pm Rofs \geq Rlmt3$

$$OVRb = \frac{OVR2 - OVR3}{Rlmt2 - Rlmt3} \times (Rcp \pm Rofs - Rlmt3) + OVR3$$

When $Rlmt3 > Rcp \pm Rofs \geq Rlmt4$

$$OVRb = \frac{OVR3 - OVR4}{Rlmt3 - Rlmt4} \times (Rcp \pm Rofs - Rlmt4) + OVR4$$

When $Rlmt4 > Rcp \pm Rofs \geq Rlmt5$

$$OVRb = \frac{OVR4 - OVR5}{Rlmt4 - Rlmt5} \times (Rcp \pm Rofs - Rlmt5) + OVR5$$

Rlmt1 to Rlmt5 are set in parameters 5611 to 5615, and OVR2 to OVR5 are set in parameters 5616 to 5619. OVRlo in the graph shown below denotes the lower limit imposed on the override during involute interpolation. It is set in parameter 5620.

Rcp \pm Rofs indicates Rcp + Rofs for an inside offset and Rcp - Rofs for an outside offset.

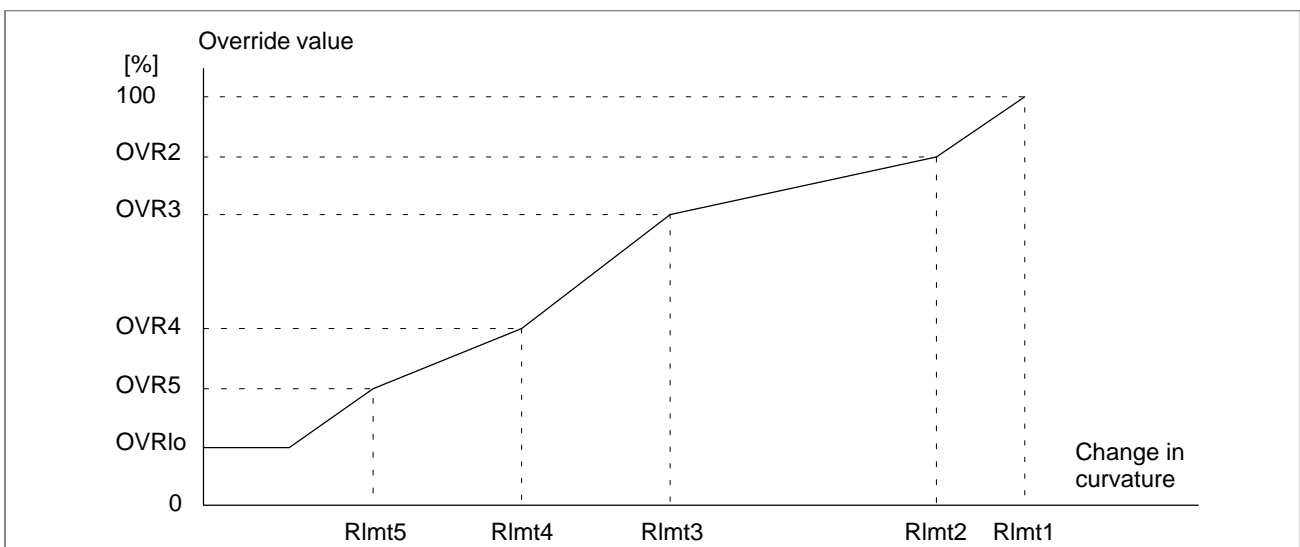

If the override calculation result is below the parameter-set lower limit, the override is clamped to the lower limit.

7.1.14.3 Signal

HPCC mode signal MHPCC <F066#6>

[Classification] Output signal

[Function] Indicates that the system is set to high-precision contour control mode (HPCC mode).

[Output condition] The signal is set to 1 if G05 P10000 (HPCC mode ON) is specified in a program. The signal is set to 0 if G05 P0 is specified in a program or if HPCC mode is canceled by a reset.

HPCC operation signal EXHPCC <F066#7>

[Classification] Output signal

[Function] Indicates that the system is operating in high-precision contour control mode (HPCC operation is in progress).

[Output condition] The signal is set to 1 if G05 P10000 (HPCC mode ON) is specified in a program and if specifiable data of except G00, M, S, T, B is executed. The signal is set to 0 when:

- (1) Automatic operation is halted.
- (2) Automatic operation is stopped.
- (3) Specifiable data of G00, M, S, T or B is executed.
- (4) HPCC mode is canceled.

For the specifiable date, refer to 7.1.14.

Signal addresses

	#7	#6	#5	#4	#3	#2	#1	#0
F066	EXHPCC	MHPCC						

7.1.14.4**Parameter****Parameters of linear accel-
eration and deceleration
before interpolation**

8400

Parameter1 for determining a linear acceleration/deceleration before interpolation

[Data type] Two-word**[Unit of data]****[Valid data range]**

Increment system	Unit of data	Valid data range	
		IS-A, IS-B	IS-C
Millimeter machine	1 mm/min	10 – 60000	1 – 6000
Inch machine	0.1 inch/min	10 – 60000	1 – 6000
Rotation axis	1 deg/min	10 – 60000	1 – 6000

This parameter determines a linear acceleration and deceleration before interpolation. Usually, set the maximum cutting speed (parameter No. 1422).

8401

Parameter2 for determining a linear acceleration/deceleration before interpolation

[Data type] Word**[Unit of data]** 1 ms**[Valid data range]** 0 to 4000

This parameter specifies the time required until the speed specified in parameter 1 is achieved.

NOTE

The function for linear acceleration/deceleration before interpolation is canceled when either parameter no. 8400 or 8401 is set to 0.

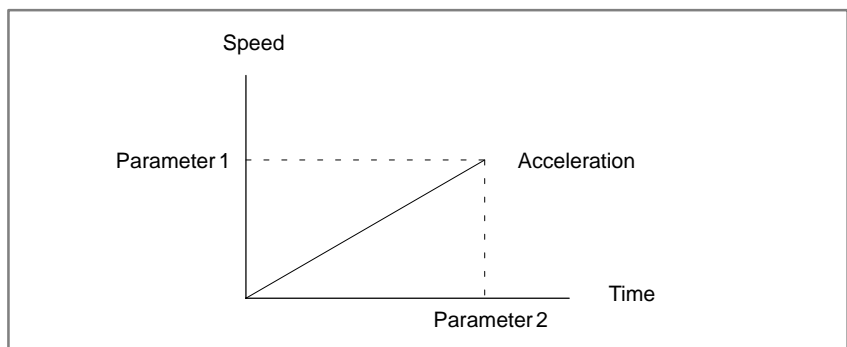

	#7	#6	#5	#4	#3	#2	#1	#0
8402	BDO		DST	BLK			NBL	

[Data type] Bit

BDO, NBL Set the type of acceleration/deceleration before interpolation.

BDO	NBL	Meaning
0	0	Acceleration/deceleration prior to interpolation is of linear type
1	1	Acceleration/deceleration prior to interpolation is of bell shape type

BLK Be sure to set to 0.

DST Be sure to set to 1.

	#7	#6	#5	#4	#3	#2	#1	#0
8403	SG0						MSU	

[Data type] Bit

MSU When G00, or an M, S, T, or B code is specified in HPCC mode:

0 : An alarm is issued.

1 : The CNC executes the command.

SG0 When G00 is specified in HPCC mode:

0 : The setting of bit 1 (MSU) of parameter No.8403 is followed.

1 : The tool is moved along the axis at the feedrate set with parameter No.8481, replacing the G00 command with the G01 command, regardless of the setting made for bit 1 (MSU) of parameter No.8403.

	#7	#6	#5	#4	#3	#2	#1	#0
8404							HG0	STG

[Data type] Bit

STG The positioning command (G00) is processed as follows on the RISC side:

0 : The tool is moved along the axis at the feedrate set with parameter No.8481, replacing the G00 command with the G01 command.

1 : The G00 command is executed as is.

CAUTION

The STG parameter is valid when the SG0 parameter (bit 7 of parameter No.8403) is set to 1.

HG0 This parameter must be set to 1 in case that positioning command (G00) is executed with the RISC board in the same way as normal G00 (parameter No.8403#7=1, No.8404#0=1).

In case this parameter is set to 1, Fine acceleration/deceleration is disabled at the rapid travers in HPCC mode.

Type of rapid traverse	MSU	SG0	STG	HG0
Executed on CNC side	1	0	0	—
Executed as G01 with the RISC board	—	1	0	—
Executed as normal G00 with the RISC board	—	1	1	MUST BE SET TO 1

Parameters of advanced preview bell-shaped acceleration/deceleration before interpolation

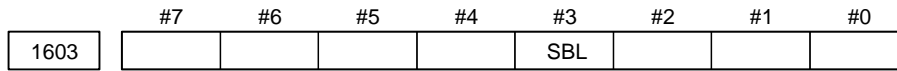

Parameter input

[Data type] Bit

SBL Look-ahead bell-shaped acceleration/deceleration before interpolation (of constant acceleration/deceleration change time type) based on RISC is:

- 0 : Disabled.
- 1 : Enabled.

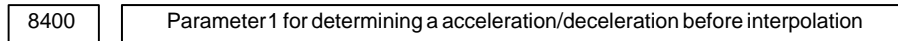

[Data type] Two-word

[Unit of data]

[Valid data range]

Increment system	Unit of data	Valid data range	
		IS-B	IS-C
Millimeter machine	1 mm/min	10 – 60000	1 – 6000
Inch machine	0.1 inch/min	10 – 60000	1 – 6000
Rotation axis	1 deg/min	10 – 60000	1 – 6000

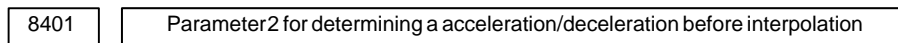

[Data type] Word

[Unit of data] 1 ms

[Valid data range] 0 to 4000

This parameter specifies the time required until the speed specified in parameter 1 is achieved.

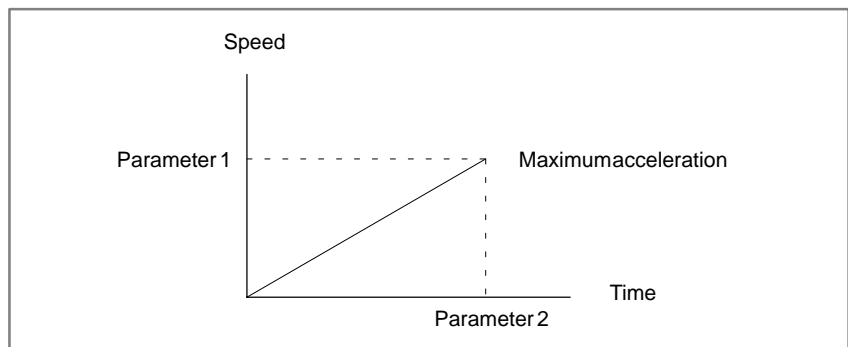

8416	The time required to the maximum acceleration in advanced preview bell-shaped acceleration/deceleration before interpolation
------	--

[Data type] Two-word

[Unit of data] msec

[Valid data range] 0 to 99999999

This parameter sets the time required to reach the maximum acceleration in advanced preview bell-shaped acceleration/deceleration before interpolation.

Also, this parameter is used for deceleration time taken from the maximum acceleration to zero.

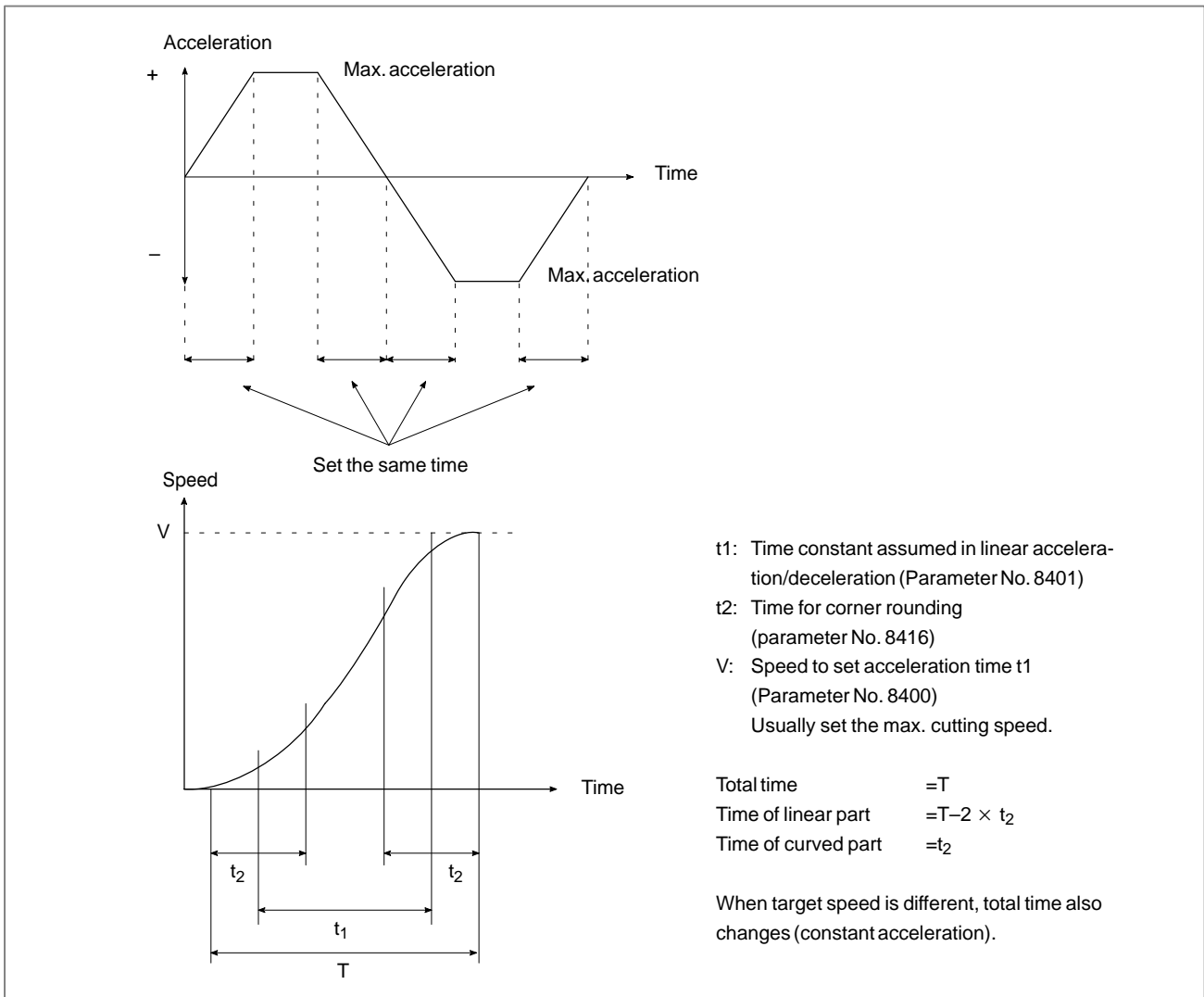

Parameters of automatic feedrate control

8410	Allowable velocity difference in velocity determination considering the velocity difference at corners
------	--

[Data type] Word axis

[Unit of data]

[Valid data range]

Increment system	Unit of data	Valid data range	
		IS-B	IS-C
Millimeter machine	1 mm/min	10 – 60000	1 – 6000
Inch machine	0.1 inch/min	10 – 60000	1 – 6000
Rotation axis	1 deg/min	10 – 60000	1 – 6000

If zero is specified for all axes, the machine does not decelerate at corners.

When the function for determining the velocity considering the velocity difference at corners is used, the system calculates the feedrate whereby a change in the velocity element of each axis does not exceed this parameter value at the interface between blocks. Then the machine decelerates using acceleration/ deceleration before interpolation.

	#7	#6	#5	#4	#3	#2	#1	#0
8451	NOF			ZAG				USE

[Data type] Bit

USE Automatic velocity control is:

0 : Not applied.

1 : Applied.

ZAG The velocity is:

0: Not determined according to the angle at which the machine descends along the Z-axis.

1: Determined according to the angle at which the machine descends along the Z-axis.

NOF In a block where automatic velocity control is validated, the F command is:

0 : Validated.

1 : Ignored.

(Maximum speed of automatic feedrate control set by parameter No. 8465 is used for command speed in spite of F command)

8452	Range of velocity fluctuation to be ignored
------	---

[Data type] Byte

[Unit of data] %

[Valid data range] 0 to 100 (Standard setting: 10)

8456	Area-2 override
------	-----------------

[Data type] Word

[Unit of data] %

[Valid data range] 1 to 100 (Standard setting: 80)

This parameter specifies an override in area 2 of velocity calculation considering the cutting load.

8457	Area-3 override
------	-----------------

[Data type] Word

[Unit of data] %

[Valid data range] 1 to 100 (Standard setting: 70)

This parameter specifies an override in area 3 of velocity calculation considering the cutting load.

8458	Area-4 override
------	-----------------

[Data type] Word

[Unit of data] %

[Valid data range] 1 to 100 (Standard setting: 60)

This parameter specifies an override in area 4 of velocity calculation considering the cutting load.

	#7	#6	#5	#4	#3	#2	#1	#0
8459							CTY	CDC

[Data type] Bit

CDC Be sure to set this value to 0.

CTY Be sure to set this value to 1.

8464	Initial feedrate for automatic feedrate control
------	---

[Data type] Two-word

[Unit of data]

[Valid data range]

Increment system	Unit of data	Valid data range	
		IS-B	IS-C
Millimeter machine	1 mm/min	10 – 240000	1 – 100000
Inch machine	0.1 inch/min	10 – 96000	1 – 48000
Rotation axis	1 deg/min	10 – 240000	1 – 100000

This parameter sets the initial feedrate for automatic feedrate control.

In automatic feedrate control, the initial feedrate set with this parameter is used at the beginning if no F command is specified in the program. Usually, set the maximum cutting feedrate (specified in parameter No. 1422).

8465	Maximum allowable feedrate for automatic feedrate control
------	---

[Data type] Two-word

[Unit of data]

[Valid data range]

Increment system	Unit of data	Valid data range	
		IS-B	IS-C
Millimeter machine	1 mm/min	10 – 240000	1 – 100000
Inch machine	0.1 inch/min	10 – 96000	1 – 48000
Rotation axis	1 deg/min	10 – 240000	1 – 100000

This parameter sets the maximum allowable feedrate for automatic feedrate control. Usually, set the maximum allowable cutting feedrate (set in parameter No. 1422).

8470	Parameter for determining allowable acceleration in feedrate calculation considering acceleration
------	---

[Data type] Word axis

[Unit of data] ms

[Valid data range] 0 to 32767

When the function for calculating the feedrate considering the acceleration is used under automatic feedrate control, this parameter is used to determine the allowable acceleration. The time required until the maximum cutting feedrate is reached must be specified here.

Allowable acceleration is determined from the maximum cutting feedrate and the value set in this parameter. Where, the maximum cutting feedrate is any of value set in parameter No. 1432, 1430 or 1422. Which parameter No. is used depends on the following conditions:

- When a value other than 0 is set to No. 1432, the value set to No. 1432 is used.
- When 0 is set to No. 1432 and a value other than 0 is set to No. 1430, the value set to No. 1430 is used.
- When 0 is set to No. 1432 and 1430, the value set to No. 1422 is used.

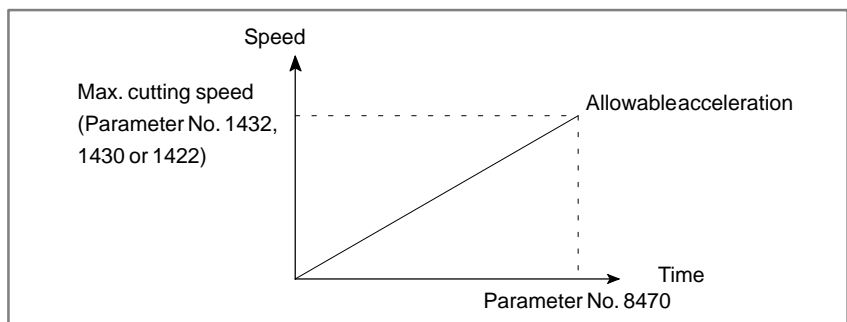

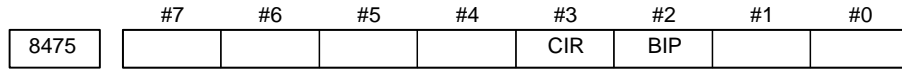

[Data type] Bit

CIR The function of automatic feedrate control considering acceleration and deceleration during circular interpolation is:

- 0 : Not used.
- 1 : Used.

When 1 is set, parameter No. 8470 for determining the allowable acceleration must be specified.

BIP The function of deceleration at corners is:

- 0 : Not used.
- 1 : Used. (Always set 1.)

Parameters of axis control

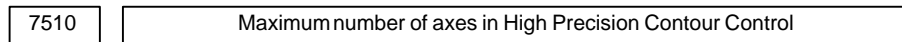

[Data type] Byte

[Valid data range] 1, 2, 3, ... to the maximum number of control axes

This parameter specifies the maximum number of axes to controlled by High Precision Contour Control.

Example) Axis configuration is X, Y, Z, A, B, and C from the 1st axis in this order and to make HPCC valid to the 4th axis (A), set this parameter to 4. In this case, HPCC is also effective for the X, Y, Z axes.

- X, Y, Z, A axes Axes on which HPCC is valid
- B, C axes Axes on which HPCC is not valid.

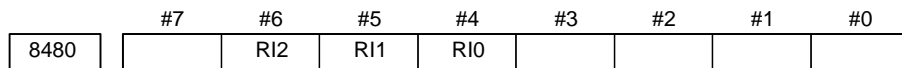

[Data type] Bit

Set the interpolation frequency during the high precision contour control mode (HPCC mode).

Be sure to set the following values:

R12	R11	R10
0	1	0

Parameters of acceleration/deceleration after interpolation

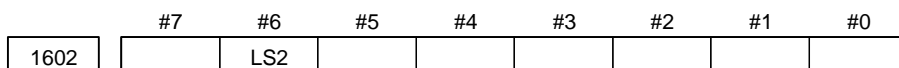

[Data type] Bit

LS2 Acceleration/deceleration after interpolation for cutting feed in the high precision contour control mode (HPCC mode) is:

- 0 : Not used. (Exponential acceleration/deceleration)
- 1 : Used. (The function for linear acceleration/deceleration after interpolation for cutting feed is required.)

1768	Time constant for linear acceleration/deceleration during cutting feed in HPCC mode
------	---

[Data type] Word axis

[Unit of data] ms

[Valid data range] 8 to 512

NOTE
The function for linear acceleration/deceleration after interpolation is required.

Parameters of cutter compensation C

	#7	#6	#5	#4	#3	#2	#1	#0
5000								SBK

[Data type] Bit

SBK An internally created block for cutter compensation C:
0 : Does not cause a single block stop.
1 : Cause a single block stop.

	#7	#6	#5	#4	#3	#2	#1	#0
5003				BCK	ICK			

[Data type] Bit

ICK In HPCC mode, when cutter compensation C interference check is:
0 : Done
1 : Not done

BCK In HPCC mode, when cutter compensation C interference check determines that the programmed move direction differs from the offset move direction by between 90 and 270 degrees:
0 : An alarm is issued.
1 : No alarm is issued.

Parameters related to involute interpolation

5611	Radius of curvature at the cutting point for the start point of override 1 near the basic circle
5612	Radius of curvature at the cutting point for the start point of override 2 near the basic circle
5613	Radius of curvature at the cutting point for the start point of override 3 near the basic circle
5614	Radius of curvature at the cutting point for the start point of override 4 near the basic circle
5615	Radius of curvature at the cutting point for the start point of override 5 near the basic circle

[Data type] 2-word

[Unit of data]	Increment system	IS-B	IS-C	Unit
	Metric input	0.001	0.0001	mm
	Inch input	0.0001	0.00001	inch

[Valid data range] 1 to 99999999

5616	Override value at the start of override 2 near the basic circle
5617	Override value at the start of override 3 near the basic circle
5618	Override value at the start of override 4 near the basic circle
5619	Override value at the start of override 5 near the basic circle

[Data type] Byte

[Unit of data] %

[Valid data range] 1 to 100

5620	Lower limit imposed on the override during involute interpolation
------	---

[Data type] Byte

[Unit of data] %

[Valid data range] 1 to 100

5621	
	Lower override limit during involute interpolation

[Data type] Word

[Unit of data] ms

[Valid data range] 1 to 32767

This parameter is used to set the maximum acceleration speed while constant acceleration control is applied during involute interpolation in high-precision contour control mode.

Set the time required until the speed set in parameter No. 8400 for setting the acceleration for linear acceleration/deceleration before interpolation is reached.

5622	
	Minimum speed while constant acceleration control is applied during involute interpolation

[Data type] Word

[Unit of data]

Increment system	IS-A	IS-B	IS-C	Unit
Metric machine	100.0	10.0	1.0	mm/min
Inch machine	10.0	1.0	0.1	inch/min
Rotation axis	100.0	10.0	1.0	deg/min

[Valid data range] 1 to 32767

This parameter is used to set the minimum deceleration speed during deceleration according to the maximum acceleration speed (parameter No. 5621) while constant acceleration control is applied during involute interpolation in high-precision contour control mode.

NOTE

When parameter No. 5621 or 5622 is set to 0, constant acceleration control is not applied during involute interpolation in high-precision contour control mode.

The other parameters

	#7	#6	#5	#4	#3	#2	#1	#0
6901					PSF			

[Data type] Bit

PSF In high-precision contour control mode (M series), AI contour control mode (M series), AI nano-contour control mode (M series), or advanced preview control mode, position switches are:

0 : Not used.

1 : Used.

NOTE

1 The position switch signals are output considering acceleration/deceleration after interpolation and servo delay. Acceleration/deceleration after interpolation and servo delay are considered even for position switch signal output in a mode other than the high-precision contour control (M series), AI contour control (M series), AI nano contour control (M series), and advanced preview control modes. Note that as a result, the setting of this parameter changes the timing of position switch signal output.

2 When using the high-speed position switch of decision-by-direction type, set bit 1 (HPE) of parameter No. 8501 to 0 (to consider a servo delay amount for decision of direction).

	#7	#6	#5	#4	#3	#2	#1	#0
8403	SG0				LM2	LM1	MSU	

[Data type] Bit

MSU When G00, or an M, S, T, or B code is specified in HPCC mode:

0 : An alarm is issued.

1 : The CNC executes the command.

LM1 In HPCC mode, a stroke check before movement for stored stroke limit 1 is:

0 : Not performed.

1 : Performed.

NOTE

The stored stroke check switching signal is invalid.

A check is made for a forbidden area specified in parameter Nos. 1320 and 1321.

LM2 In HPCC mode, a stroke check before movement for the second stored stroke limit is:

- 0 : Not performed.
- 1 : Performed.

SG0 When G00 is specified in HPCC mode:

- 0 : The setting of bit 1 (MSU) of parameter No. 8403 is followed.
- 1 : The tool is moved along the axis at the feedrate set with parameter No. 8481, replacing the G00 command with the G01 command, regardless of the setting made for bit 1 (MSU) of parameter No. 8403. Refer to note 1 in description of parameter No. 8481.

	#7	#6	#5	#4	#3	#2	#1	#0
8404								STG

[Data type] Bit

STG The positioning command (G00) is:

- 0 : Executed with the RISC board in a simplified manner.
- 1 : Executed with the RISC board in the same way as normal.

NOTE

This parameter is enabled when the SG0 parameter (bit 7 of parameter No.8403) is set to 1.

8481	Rapid-traverse rate in HPCC mode
------	----------------------------------

[Data type] Two-word axis

[Unit of data] [Valid data range]	Increment system	Unit of data	Valid data range	
			IS-B	IS-C
	Millimeter machine	1 mm/min	10 – 240000	1 – 100000
	Inch machine	0.1 inch/min	10 – 96000	1 – 48000
	Rotation axis	1 deg/min	10 – 240000	1 – 100000

When bit 7 (SG0) of parameter No. 8403 is set to 1, this parameter sets the rapid traverse rate in the HPCC mode.

CAUTION

The G00 command is replaced with the G01 command before execution. So, even if a feedrate is specified for two axes, the rapid traverse rate set with this parameter is always used.

Example:

If the following command is specified when a rapid traverse rate of 1000 mm/min is set F1000, instead of F1414:

G00 X100.Y100.;

For details, refer to Notes on positioning (G00).

	#7	#6	#5	#4	#3	#2	#1	#0
8485			CDS	INV	PRW	G02	G81	G51

[Data type] Bit

G51 In high-precision contour control (HPCC) mode, the scaling/coordinate system rotation functions are:

- 0 : Disabled.
- 1 : Enabled.

G81 In high-precision contour control (HPCC) mode, the hole machining canned cycle is:

- 0 : Disabled.
- 1 : Enabled.

G02 In high-precision contour control (HPCC) mode, helical interpolation is:

- 0 : Disabled.
- 1 : Enabled.

PRW In high-precision contour control (HPCC) mode, parameter rewriting by PMC WINDOW is:

- 0 : Disabled.
- 1 : Enabled.

INV In high-precision contour control (HPCC) mode, involute interpolation is:

- 0 : Disabled.
- 1 : Enabled.

CDS In high-precision contour control (HPCC) mode, smooth interpolation is:

- 0 : Disabled.
- 1 : Enabled.

7.1.14.5**Alarm and message**

Number	Message	Description
5000	ILLEGAL COMMAND CODE(HPCC)	An invalid command (G code etc.) was specified in HPCC mode.
5003	ILLEGAL PARAMETER (RISC)	Parameter setting is erroneous.
5004	RISC NOT READY	RISC processor board is not ready state.
5006	TOO MANY WORD IN ONE BLOCK	The number of words in a block exceeds allowable range (HPCC mode).
5012	G05 P10000 ILLEGAL START UP	G05P10000 was specified in a mode from which HPCC mode cannot be entered.
5013	HPCC : CRC OFS RE-MAIN AT CANCEL	G05P0 was specified in G41/G42 mode or a state in which an offset value remains.

7.1.14.6

Note

- Acceleration/deceleration before interpolation in look-ahead blocks

NOTE

If there is a series of very short blocks, for each of which the rate of acceleration/deceleration before interpolation is low, the actual feedrate may not reach the programmed feedrate.

- Automatic feedrate control

NOTE

- 1 If the upper limit for automatic feedrate control is set to 0 in parameter No. 8465, no feedrate exceeding 0 is permitted, such that the issue of an F command causes PS alarm 011 (FEED ZERO). To prevent this, specify a value other than zero in the parameter.
- 2 If the override is changed while the automatic feedrate control function is enabled, the calculated clamp feedrate is overridden.
- 3 Programmable mirror image and a scaling magnification of -1 cannot be used.

- Notes on operation

WARNING

- 1 In HPCC mode, axial interlocking (each axis, each direction) is inhibited (signals G130, G132, G134).
- 2 In HPCC mode, the external mirror image (DI) signal, a mirror image determined by setting data, or axial machine lock must not be changed. Pocket calculator type decimal point input is disabled in HPCC mode (when bit 0 of parameter No. 3401 is set to 1).

NOTE

- 1 A single-block stop cannot be made at the end of the G05P10000 block.
- 2 External deceleration, the F1-digit command, and automatic corner override are disabled.
- 3 In HPCC mode, the operation mode cannot be switched to MDI mode. Also, MDI operation is not permitted.
- 4 A program including G50 P10000; cannot be resumed.

**Notes on positioning
(G00)**

When executing a G00 command when bit 7 of parameter No. 8403 (SG0) is set to 1, note the following:

WARNING

Linear interpolation positioning is performed.

CAUTION

- 1 The G00 command is replaced with the G01 command upon being executed. Even if two axes are specified, movement is performed at the feedrate specified in parameter No. 8481.

Example)

If the following command is specified when parameter No. 8481 is set to 1000 mm/min, F1000 is executed instead of F1414:

G00 X100. Y100.;

- 2 Because the G00 command is replaced with the G01 command upon being executed, rapid traverse override is disabled, the cutting feedrate override being enabled instead.

NOTE

- 1 Because the G00 command is replaced with the G01 command upon being executed, acceleration/deceleration after interpolation is done using the time constant of acceleration/deceleration after interpolation for cutting feed.
- 2 Because the G00 command is replaced with the G01 command upon being executed, acceleration/deceleration before interpolation in RISC HPCC mode is enabled. (Both linear acceleration/deceleration and bell-shaped acceleration/deceleration are supported.)
- 3 In-position check is not executed.

7.1.14.7**Reference item**

Series 16i/18i/160i/180i/ 160is/180is	OPERATOR'S MANUAL (For Machining Center) (B-63534EN)	II.19.8	High-precision contour control
---	--	---------	--------------------------------

7.1.15 Positioning by Optimal Acceleration

General

When a rapid traverse command is specified during automatic operation, the function positioning by optimal acceleration can be used to adjust the rapid traverse rate, time constant, and loop gain, according to the amount of travel for the block. This reduces the time required for positioning and position check, therefore reducing the cycle time.

When rapid traverse is specified in automatic operation, the function adjusts the rapid traverse rate, time constant, and loop gain to one of seven levels, according to the amount of travel for the block. The relationship between the amount of travel and the corresponding rapid traverse rate, time constant, and loop gain are specified in parameters. This function is not effective for cutting feed. (For cutting feed, the loop gain set in parameter 1825 is used.)

Valid commands

This function is effective for all commands that cause rapid traverse in automatic operation, including commands for canned cycles, automatic reference position return, and machine coordinate system selection, as well as the G00 command. This function, however, becomes ineffective in the following cases, and the feedrate, time constant, and loop gain set in parameters 1420, 1620 and 1825 are used:

- (1) When an automatic reference position return (G28) is specified before the reference position is established
- (2) When the G00 command is executed on the RISC side in high-precision contour control (when bit 7 (SG0) of parameter 8403 is set to 1)
- (3) In AI contour control mode
- (4) In Cs axis contour control mode
- (5) Rigid tapping mode

Cutting feed

This function is not effective for cutting feed.

Manual operation

This function is not effective in manual operation. The function is not effective for movement caused by manual numeric commands.

Manual intervention

When rapid traverse is stopped by feed hold or mode change during automatic operation, and manual operation is performed, the loop gain is changed to the value set in parameter 1825. When the program is restarted, the interrupted block is resumed without changing the loop gain used in manual operation. Then, when the next and subsequent blocks are executed, one of the values set in parameters 6181 to 6187 is used again as the loop gain.

PMC axis control

This function is not effective during PMC axis control.

Rapid traverse overlap

When this function is enabled, rapid traverse overlap (enabled when bit 4 (RTO) of parameter 1601 is set to 1) is not performed.

**Rapid traverse
bell-shaped
acceleration/deceleration**

When rapid traverse bell-shaped acceleration/deceleration is used, $T1$ in the figure below and the rapid traverse rate are adjusted. $T2$ is not adjusted.

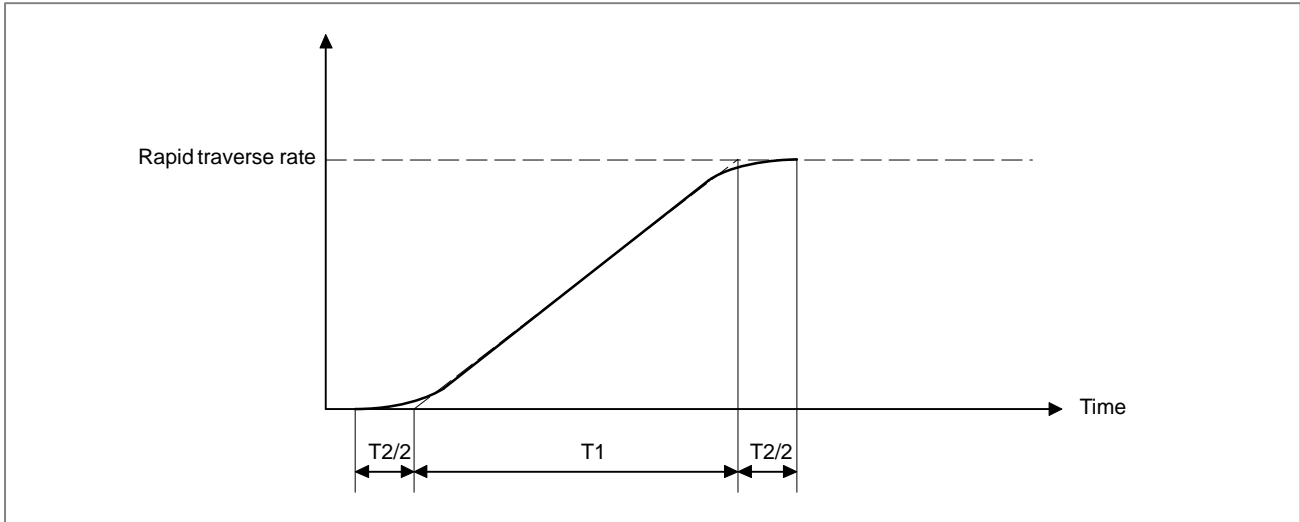
**Angular axis control**

When angular axis control is used, adjustment is performed according to the amount of travel in the Cartesian coordinate system.

**Coordinate system
rotation, scaling**

In coordinate system rotation mode, adjustment is performed according to the amount of travel after coordinate system rotation. In scaling mode, adjustment is performed in a similar manner.

**Cutter compensation C,
tool nose radius
compensation**

In cutter compensation C or tool nose radius compensation mode, adjustment is performed according to the amount of travel after compensation.

**Three-dimensional
coordinate conversion**

In three-dimensional coordinate conversion mode, adjustment is performed according to the amount of travel before coordinate conversion.

**Polar coordinate
interpolation**

In polar coordinate interpolation mode, adjustment is performed according to the amount of travel in the Cartesian coordinate system.

**Simple synchronous
control**

When using this function with simple synchronous control, enable this function for both the master and slave axes (by setting bit 0 (OAD) of parameter 6131 to 1), and set the same rapid traverse rate, time constant, and loop gain values for both the master and slave axes.

**Rapid traverse of linear
interpolation type**

When rapid traverse of linear interpolation type is being used (when bit 1 (LRP) of parameter 1401 is set to 1), adjustment is performed. But the feedrate for each axis is determined so that the tool path becomes linear. Therefore, the tool does not always move at a parameter-set rapid traverse rate (parameters 6161 to 6167).

Parameter

	#7	#6	#5	#4	#3	#2	#1	#0
6131								OAD

[Data type] Bit axis

OAD The function for positioning by optimal acceleration is:
0 : Disabled.
1 : Enabled.

6141	Distance D1 for level 1 (metric input, or rotation axis)
------	--

6142	Distance D2 for level 2 (metric input, or rotation axis)
------	--

6143	Distance D3 for level 3 (metric input, or rotation axis)
------	--

6144	Distance D4 for level 4 (metric input, or rotation axis)
------	--

6145	Distance D5 for level 5 (metric input, or rotation axis)
------	--

6146	Distance D6 for level 6 (metric input, or rotation axis)
------	--

6151	Distance D1 for level 1 (inch input)
------	--------------------------------------

6152	Distance D2 for level 2 (inch input)
------	--------------------------------------

6153	Distance D3 for level 3 (inch input)
------	--------------------------------------

6154	Distance D4 for level 4 (inch input)
------	--------------------------------------

6155	Distance D5 for level 5 (inch input)
------	--------------------------------------

6156	Distance D6 for level 6 (inch input)
------	--------------------------------------

[Data type] 2-word

[Unit of data]	Increment system	IS-B	IS-C	Unit
	Metric input, rotation axis	0.001	0.0001	mm, deg
	Inch input	0.0001	0.00001	inch

[Valid data range] 0 to 99999999

These parameters set the positioning distances used when the function for adjusting the rapid traverse rate, time constant, and loop gain to one of seven levels according to the positioning distance is used. (The settings are common to all axes.)

NOTE

- 1 The settings must satisfy the relationship $D1 < D2 < D3 < D4 < D5 < D6$.
- 2 Up to seven levels can be used for adjustment. When using four levels, for example, set D4 to 99999999.
- 3 For diameter programming axes, set a diameter. For example, assume that 10.000 mm is set in a parameter for diameter programming axes. Then, when the amount of travel has reached 10.000 mm, adjustment is performed.

6161	Level 1 rapid traverse rate
6162	Level 2 rapid traverse rate
6163	Level 3 rapid traverse rate
6164	Level 4 rapid traverse rate
6165	Level 5 rapid traverse rate
6166	Level 6 rapid traverse rate
6167	Level 7 rapid traverse rate

[Data type] 2-word axis

[Unit of data]	Increment system	Unit of data	Valid data range
[Valid data range]	Millimeter machine	1 mm/min	30 to 240000
	Inch machine	0.1 inch/min	0 to 96000

The rapid traverse rate for each axis is set.

6171	Level 1 rapid traverse time constant
6172	Level 2 rapid traverse time constant
6173	Level 3 rapid traverse time constant
6174	Level 4 rapid traverse time constant
6175	Level 5 rapid traverse time constant
6176	Level 6 rapid traverse time constant
6177	Level 7 rapid traverse time constant

[Data type] Word axis

[Unit of data] ms

[Valid data range] 8 to 4000

The rapid traverse time constant for each axis is set.

6181	Level 1 servo loop gain
6182	Level 2 servo loop gain
6183	Level 3 servo loop gain
6184	Level 4 servo loop gain
6185	Level 5 servo loop gain
6186	Level 6 servo loop gain
6187	Level 7 servo loop gain

[Data type] Word axis

[Unit of data] 0.01 s^{-1}

[Valid data range] 1 to 9999

The servo loop gain for each axis is set.

Positioning distances and corresponding parameter Nos.

Level	Positioning distance d	Rapid traverse rate	Rapid traverse time constant	Servo loop gain
1	$0 < d \leq D1$	6161	6171	6181
2	$D1 < d \leq D2$	6162	6172	6182
3	$D2 < d \leq D3$	6163	6173	6183
4	$D3 < d \leq D4$	6164	6174	6184
5	$D4 < d \leq D5$	6165	6175	6185
6	$D5 < d \leq D6$	6166	6176	6186
7	$D6 < d$	6167	6177	6187

7.1.16 AI Contour Control/AI Nano Contour Control (M series)

General

This function includes many of the features found in high-precision contour control using a RISC processor but it enables high-speed and high-precision machining without the need for special hardware.

This function is designed for high-speed high-precision machining. The use of this function enables the suppression of the delay in the servo system and the delay in acceleration/deceleration which increases as the feedrate increases, therefore reducing the machining profile error.

AI contour control enables look-ahead acceleration/deceleration before interpolation that reads up to 40 blocks in advance, and AI nano contour control enables look-ahead acceleration/deceleration before interpolation that read up to 180 blocks in advance. Thus, smooth acceleration/deceleration can be performed over many blocks, and high-speed machining can be performed.

With AI nano contour control, a position command to be output to the digital servo system is calculated in nanometers by nano interpolation, so that the machine moves very smoothly for improved surface precision.

Format

G05.1 Q_ ;

Q1: AI contour control/AI nano contour control mode ON
Q0: AI contour control/AI nano contour control mode OFF

NOTE

- 1 Be sure to specify G05.1 in a single block.
- 2 The AI contour control/AI nano contour control mode can also be turned off by a reset.
- 3 If the option for AI nano contour control is selected, the AI contour control mode is set by setting bit 0 (NAN) of parameter No. 7053 to 1.

Functions enabled in the AI contour control/AI nano contour control mode

- (1) Nano interpolation (AI nano contour control only)
- (2) Look-ahead linear acceleration/deceleration before interpolation
- (3) Look-ahead bell-shaped acceleration/deceleration before interpolation (The option for look-ahead bell-shaped acceleration/deceleration before interpolation is required.)
- (4) Automatic corner deceleration
- (5) Feedrate clamping by acceleration
- (6) Feedrate clamping by arc radius
- (7) Block overlap (up to 5 blocks)
- (8) Advanced feed-forward

Nano interpolation (AI nano contour control only)

A program conventionally used (IS-B command or IS-C command) can be used, and a position command to be output to the digital servo system is calculated in nanometers. As a result, a smooth position command is output to the servo system, so that the machine moves very smoothly for improved surface precision.

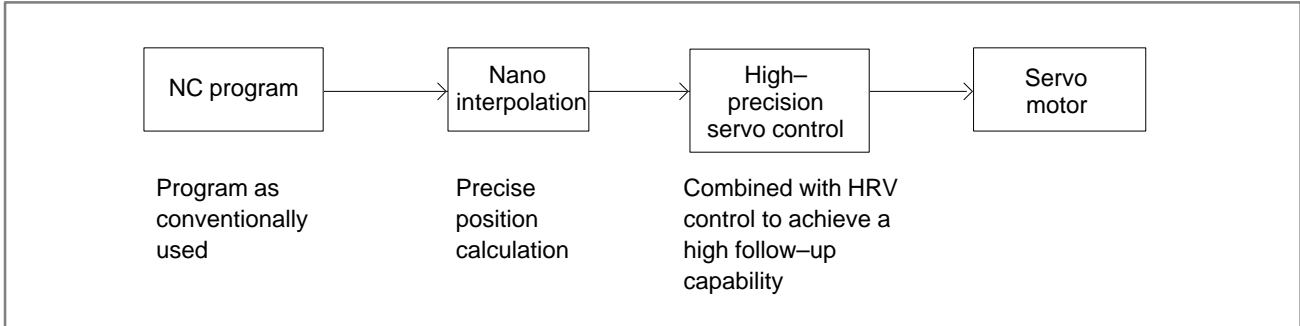

NOTE
The precision of positioning is represented in the unit of the detection system.

Look-ahead linear acceleration/deceleration before interpolation

For a cutting feed command in feed per minute mode, look-ahead control of up to 40 blocks (AI contour control) or 180 blocks (AI nano contour control) can be performed, and linear acceleration/deceleration can be performed for a programmed feedrate (before interpolation). When acceleration/deceleration is performed after interpolation, acceleration/deceleration is performed for the data resulting from the interpolation, which changes the interpolation data. For acceleration/deceleration before interpolation, on the other hand, acceleration/deceleration is performed on the feedrate data before the interpolation, so that the interpolation data is not changed by acceleration/deceleration. Therefore, interpolation data can always be aligned with a specified line or curve to eliminate any machining profile errors caused by a delay in acceleration/deceleration.

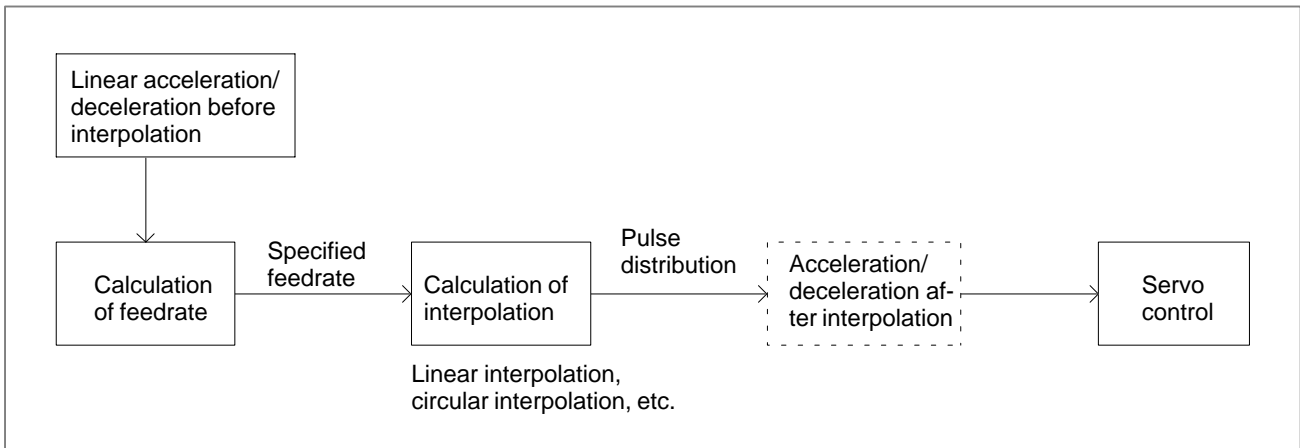

(Example of deceleration)

To execute a block at a specified feedrate, the feedrate is reduced from that of the previous block.

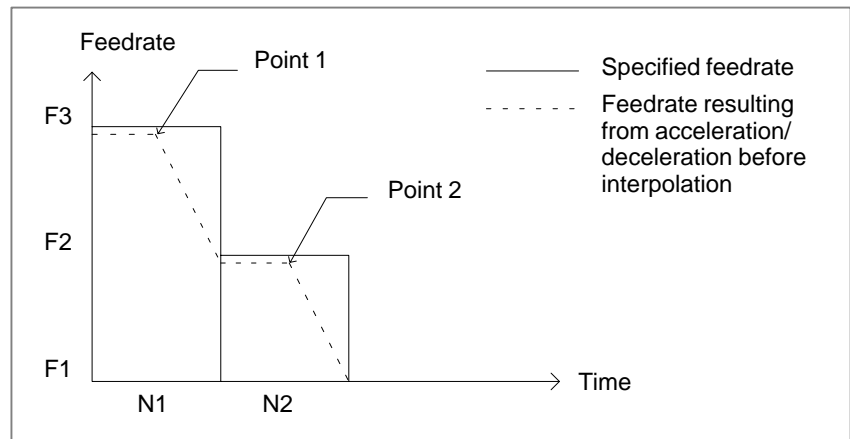

To reduce the feedrate from F3 to F2, deceleration must be started at Point 1.

To decrease the feedrate from F2 to F1, deceleration must be started at Point 2.

Since advanced preview control for multiple blocks is performed, deceleration over multiple blocks can be performed.

(Example of acceleration)

To execute a block at a specified feedrate, the feedrate is increased.

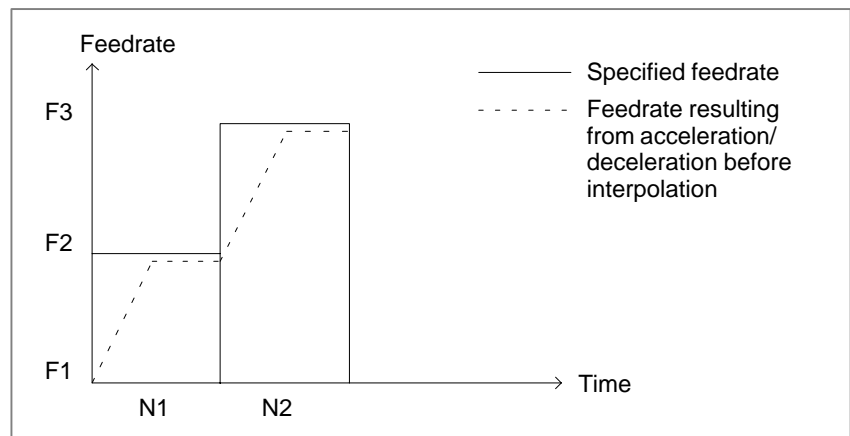

Look-ahead bell-shaped acceleration/deceleration before interpolation (The option for look-ahead bell-shaped acceleration/deceleration before interpolation is required.)

Acceleration/deceleration before interpolation for cutting feedrate in the AI contour control/AI nano contour control mode can be switched from the linear type to the bell-shaped type. The bell-shaped type can apply smooth acceleration/deceleration to the cutting feedrate, so that a mechanical shock caused by a change in acceleration/deceleration when the cutting feedrate is changed can be reduced.

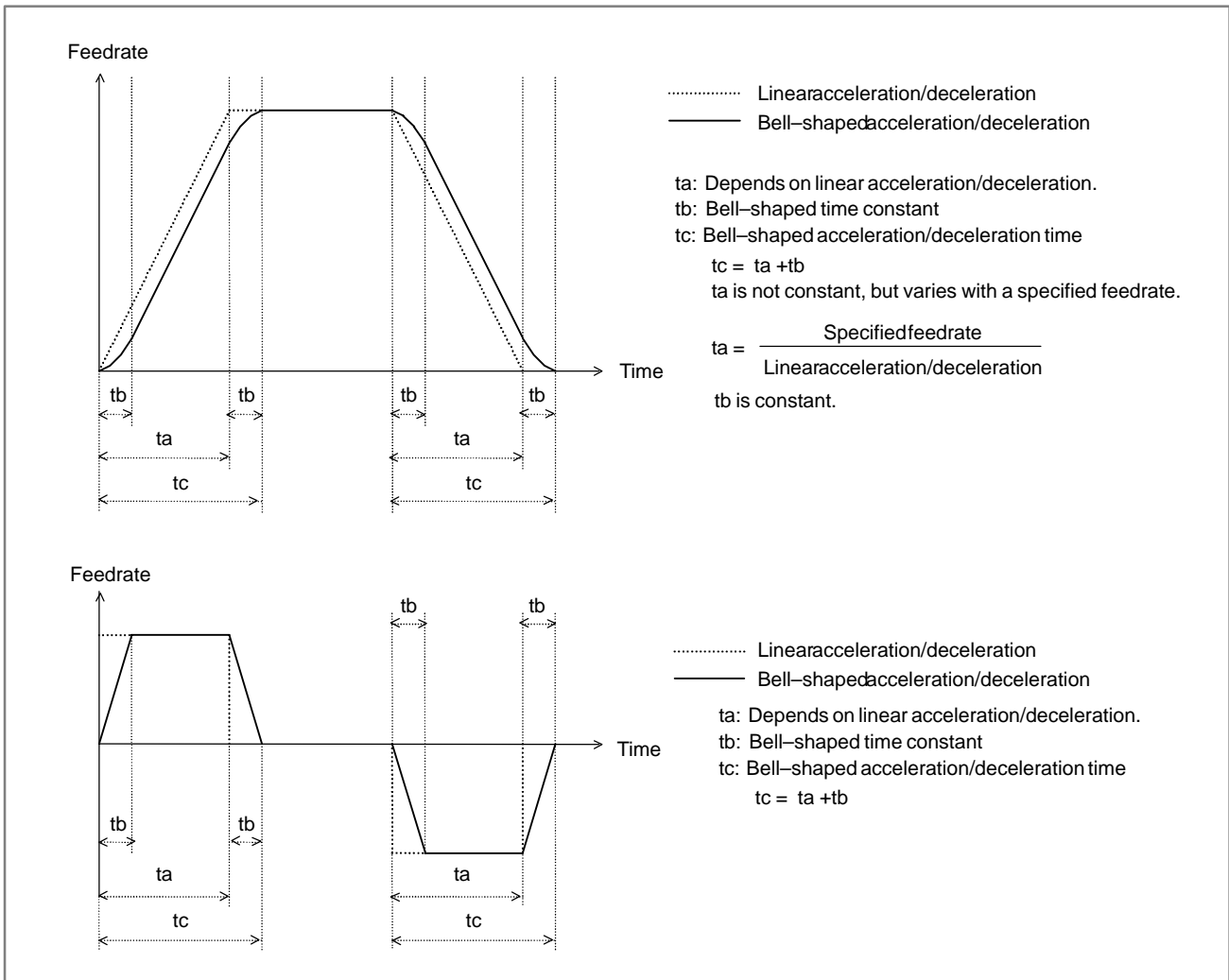

Acceleration/deceleration is performed as described below when the feedrate is changed.

Deceleration: In order to end deceleration before entering into a block that changes the feedrate, bell-shaped deceleration is performed starting with the previous block.

Acceleration: After entering into a block that changes the feedrate, bell-shaped acceleration/deceleration is started.

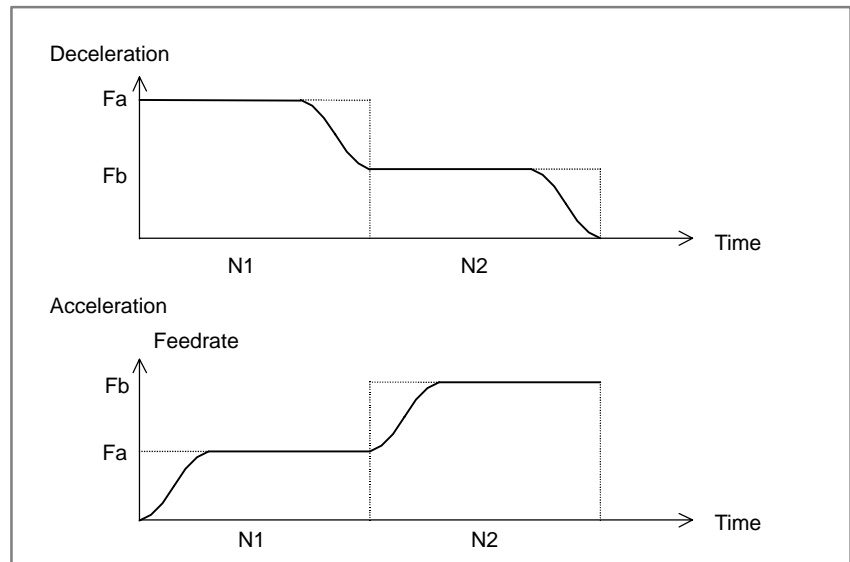

Automatic corner deceleration

When there are axes for which the difference in feedrate between blocks exceeds the allowable feedrate difference set in parameter 1783, the automatic corner deceleration function calculates the feedrate at a corner and performs deceleration so that the calculated feedrate is attained at the junction of the blocks. The feedrate at the corner is calculated as explained below, where the ratio of the difference in the actual feedrate to the allowable feedrate difference is obtained for each axis, after which the largest of these ratios is used as a reference.

The change in feedrate on each axis (V_x , V_y , ...) when the tool moves at a specified feedrate F is compared with the value set in parameter 1783 (V_{prm-x} , V_{prm-y} , ...). If the change in the feedrate for any axis exceeds the parameter-set value, the following is obtained first:

$$R_{max} = \max \left[\frac{V_x}{V_{prm-x}}, \frac{V_y}{V_{prm-y}}, \dots \right]$$

Then, the feedrate (F_c) is obtained from the following expression, after which corner deceleration is performed:

$$F_c = F \times \frac{1}{R_{max}}$$

For example, suppose that the direction of the tool movement changes through 90 degrees from X-axis movement to Y-axis movement, and also suppose that the specified feedrate is 1000 mm/min, and that the allowable feedrate difference (parameter 1783) is set to 500 mm/min. Then, deceleration is performed as shown in the figure below.

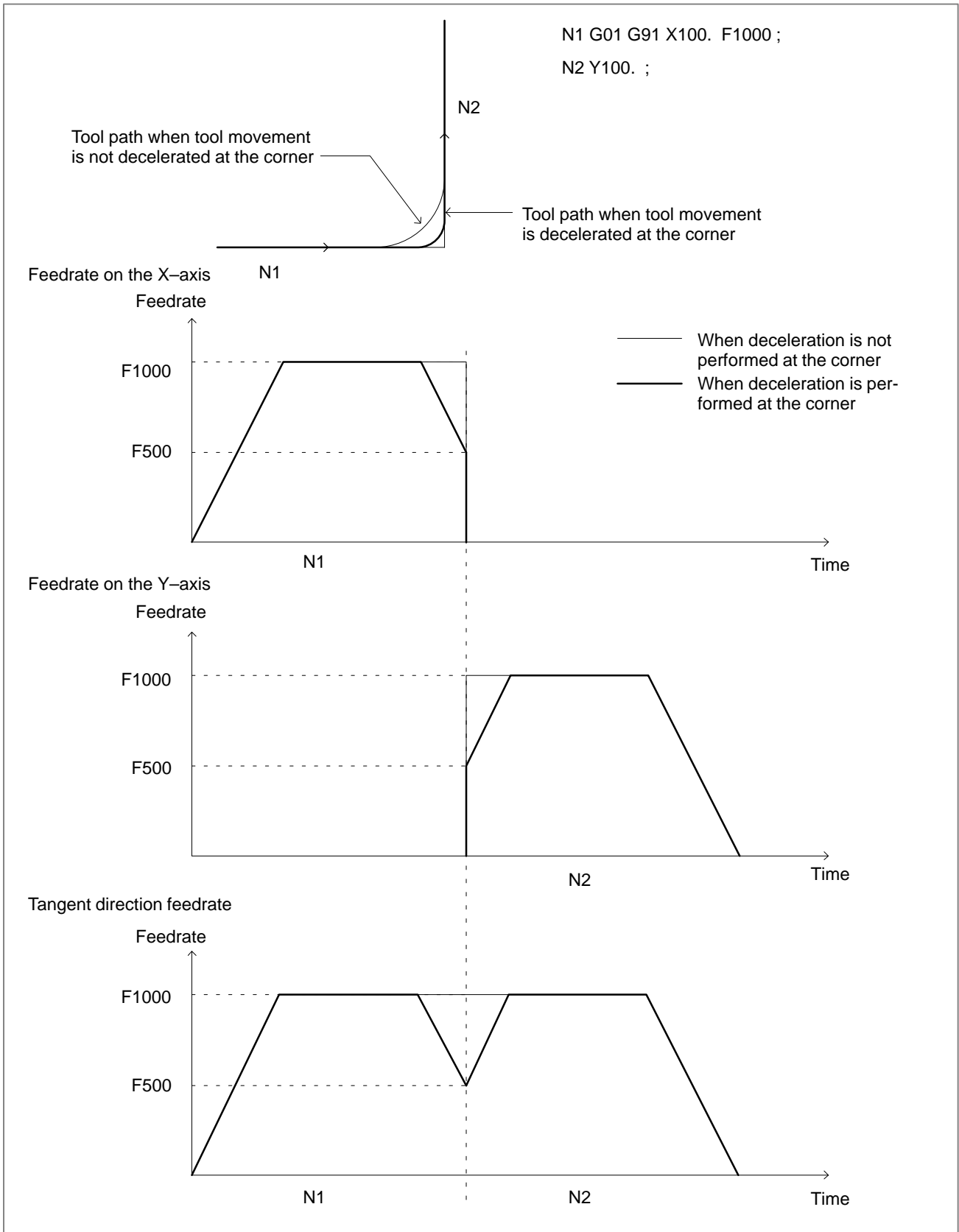

Feedrate clamping by acceleration

When a curve is made up of a series of short straight lines as shown in the figure below, the difference in feedrate on each axis at each corner is not large. Therefore, deceleration by feedrate difference is not effective. Small feedrate differences occur successively, however, so a large acceleration will be generated on each axis as a whole.

In such cases, deceleration is performed to reduce the machining error and the stress imposed on the machine, both of which are caused by excessive acceleration. The target feedrate to be reached by deceleration is set so that the acceleration on each axis, as obtained from the expression below, does not exceed the allowable acceleration set for all axes.

The allowable acceleration is set using the maximum cutting feedrate (parameter 1432) and the time required to reach the maximum cutting feedrate (parameter 1785).

Acceleration on an axis =

$$\frac{\text{Difference in feedrate on the axis at a corner}}{\max \left(\frac{\text{Amount of travel in the previous block}}{F}, \frac{\text{Amount of travel in the next block}}{F} \right)}$$

A target feedrate to be reached by deceleration is obtained for each corner. The actual feedrate is the feedrate to be reached by deceleration, as obtained at the start point of a block, or the feedrate to be reached by deceleration as obtained at the end point of the block, whichever is the lower.

Example:

In the following example, too great an acceleration/deceleration (the inclination of the dotted lines in the feedrate graphs) is observed between N2 and N4 and between N6 and N8, so deceleration is performed in these areas.

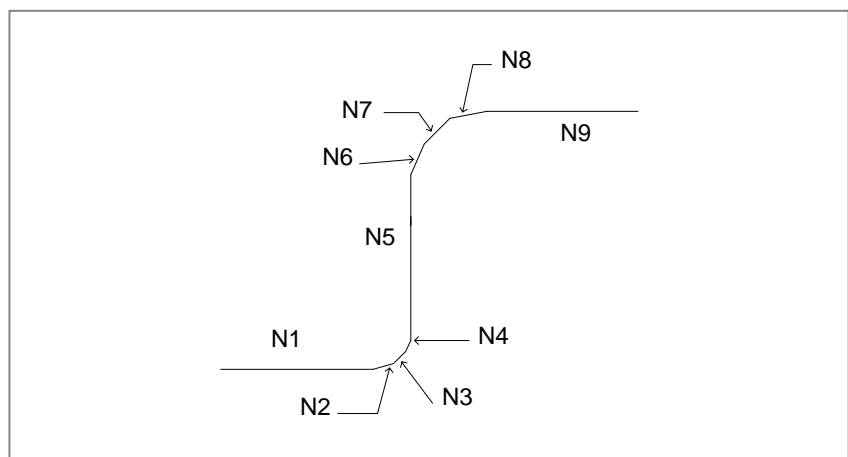

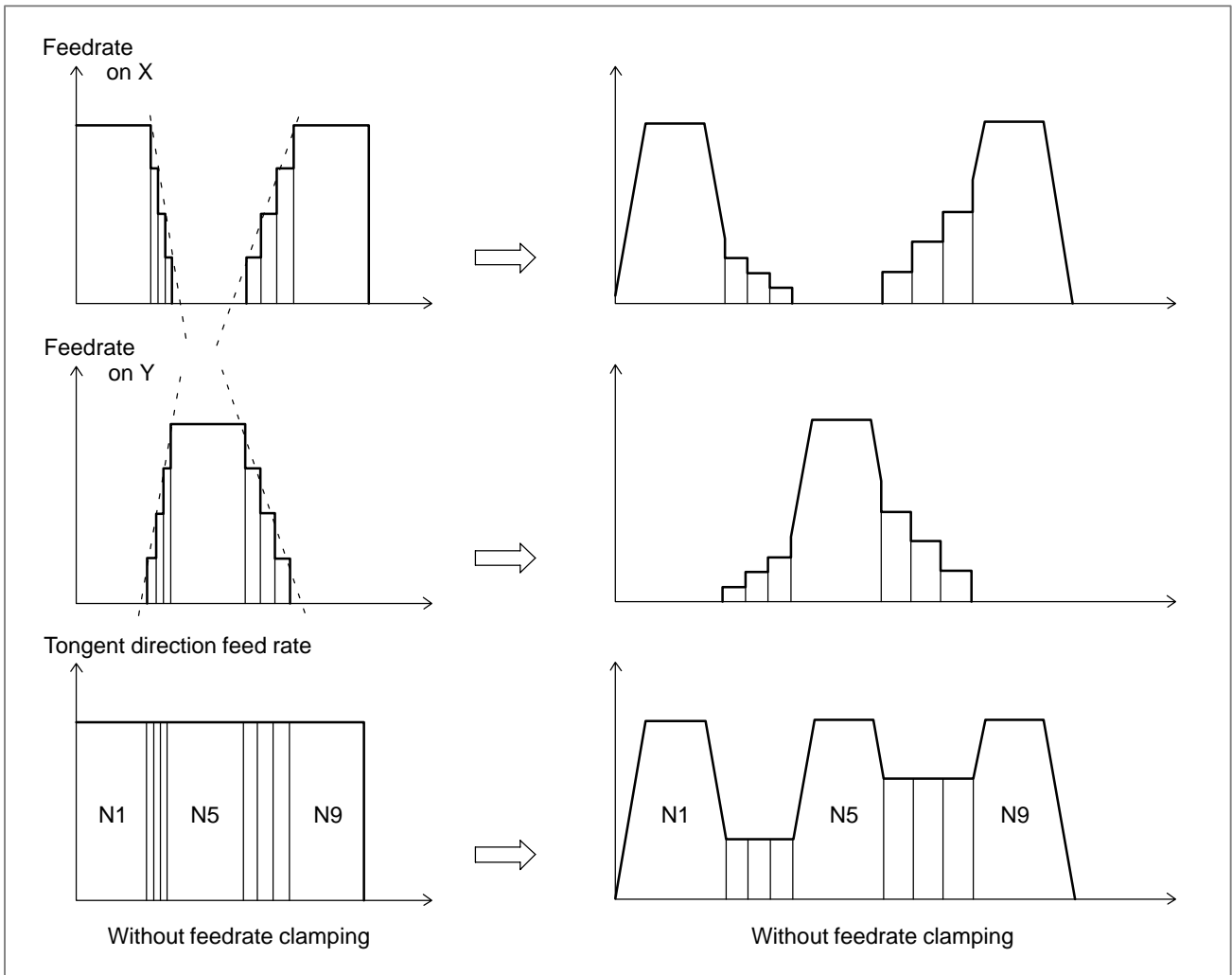

Feedrate clamping by arc radius

This function can suppress acceleration in an arc machining block to an allowable level by clamping the feedrate. Based on the arc radius R and the maximum allowable feedrate V for that arc radius (which are set in parameters), this function calculates the maximum allowable feedrate v for an arc with a programmed radius r, as shown below. If the specified feedrate exceeds feedrate V, the feedrate can be clamped to feedrate v automatically.

$$\text{Maximum allowable acceleration} = \frac{V^2}{R}$$

R : Arc radius, V : Feedrate for arc radius R

Then, the maximum allowable feedrate v for an arc with radius r is obtained from the following expression:

$$v = \sqrt{r/R} \times V$$

NOTE

As the specified arc radius becomes smaller, the maximum allowable feedrate v falls. To prevent the maximum allowable feedrate from becoming too small, the lower limit for feedrate clamping based on the arc radius can be set in parameter 1732. If the maximum allowable feedrate is less than the value set in parameter 1732, the parameter-set value can be used as the maximum allowable feedrate v .

Rapid traverse

In rapid traverse, acceleration/deceleration is performed using linear acceleration/deceleration before interpolation, and tool movement is performed by positioning based on linear interpolation. The tool movement feedrate is obtained from the rapid traverse rate for each axis which is set in parameter 1420. The acceleration in acceleration/deceleration before interpolation is obtained from the rapid traverse rate for each axis which is set in parameter 1420 and the linear acceleration/deceleration time constant for each axis in rapid traverse which is set in parameter 1620. They are obtained as follows:

(1) Tool movement feedrate

For each axis along which the tool moves, calculation is performed using the following expression. Then, from among the calculated values, the smallest value is used as the tool movement feedrate.

$$\frac{\text{Rapid traverse rate on an axis (parameter 1420)} \times \text{Amount of travel for a block}}{\text{Amount of travel along an axis}}$$

(2) Acceleration for acceleration/deceleration before interpolation

• Linear type

The smallest of the values calculated according to the expression below for those axes along which the tool moves is used as the linear acceleration/deceleration before interpolation for moving the tool.

$$\frac{\frac{\text{Rapid traverse rate along an axis (parameter No. 1420)}}{\text{Time constant for an axis (parameter No. 1620)}} \times \text{Amount of travel for a block}}{\text{Amount of travel along an axis}}$$

• Bell-shaped type

To a feedrate found from the acceleration above, the time constant set in parameter No. 1621 (rapid traverse bell-shaped acceleration/deceleration time constant for each axis) for the axis representing the smallest value of the expression above is applied.

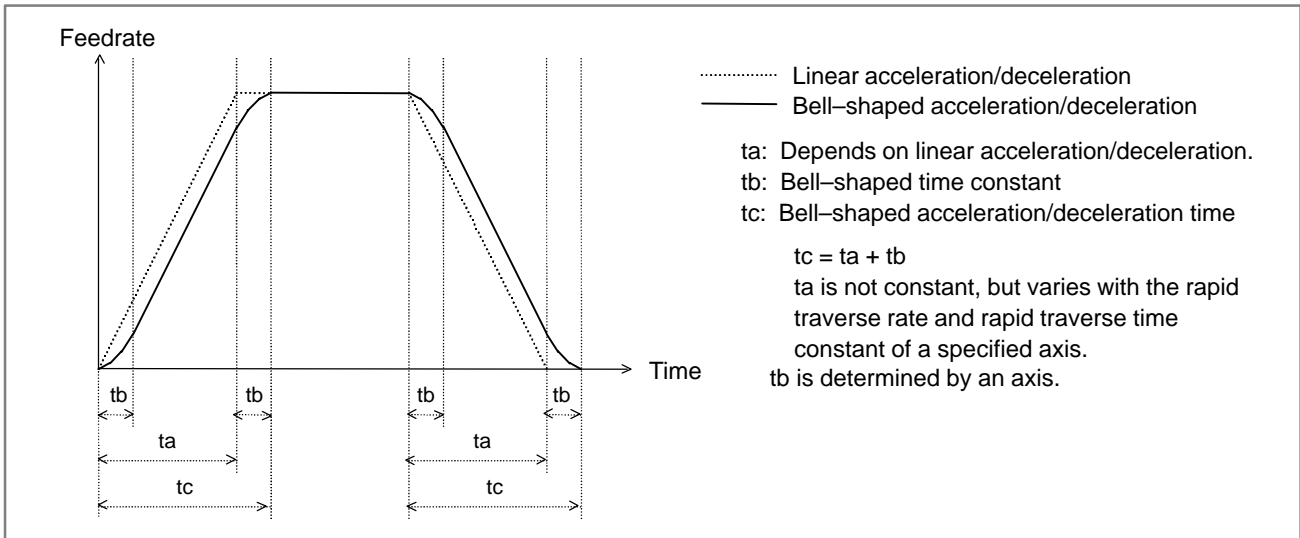

Let F be a feedrate for movement, let A be acceleration when linear acceleration/deceleration is assumed, and let T be the time constant of bell-shaped acceleration/deceleration. Then, time required for acceleration/deceleration is as follows:

$$\begin{aligned} \text{Time required for acceleration/deceleration} &= F/A \text{ (linear type)} \\ &= F/A + T \text{ (bell-shaped type)} \end{aligned}$$

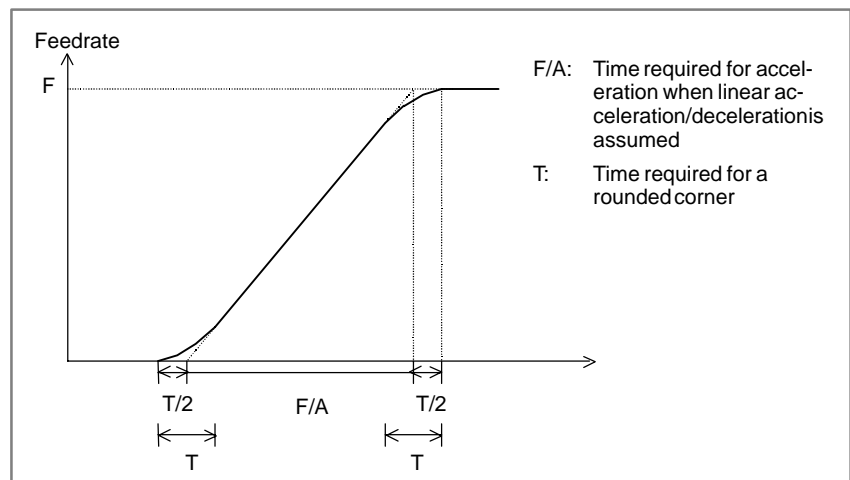

When non-linear interpolation is used, the tool moves according to the feedrate set in parameter No. 1420 and the acceleration/deceleration set in parameter No. 1620. By setting parameter No. 1621, bell-shaped acceleration/deceleration can be selected. (To select bell-shaped acceleration/deceleration, the option for rapid traverse bell-shaped acceleration/deceleration is required.)

NOTE

- 1 Overlapping between rapid traverse blocks is disabled.
- 2 To use bell-shaped acceleration/deceleration, the option for rapid traverse bell-shaped acceleration/deceleration is required.
- 3 When AI nano contour control is used, non-linear interpolation cannot be selected.

Involute interpolation

- **Override at the time of cutter compensation inside offsetting**

During involute interpolation, the following two overrides are applied to a specified cutting feedrate to produce a cutting surface of higher machining precision:

- (1) Override at the time of cutter compensation inside offsetting
- (2) Override in the neighborhood of a basic circle

When cutter compensation C is applied to involute interpolation, control is exercised so that the tangential feedrate along the tool center path during normal involute interpolation is a specified feedrate at all times. So, the feedrate of the outer point (cutting point) of the tool along the programmed path, that is, the actual cutting feedrate changes because the curvature of an involute curve changes momentarily. In particular, if the tool is offset inside an involute curve, the actual cutting feedrate becomes greater than a specified value as the tool gets closer to a basic circle.

For smooth machining, control should be exercised so that the actual cutting feedrate matches a specified feedrate. This function finds an override value that matches the curvature of a momentarily changing involute curve particularly during involute interpolation at the time of inside offsetting. This function then exercises control so that the actual cutting feedrate, that is, the tangential feedrate at a cutting point is a specified feedrate at all times.

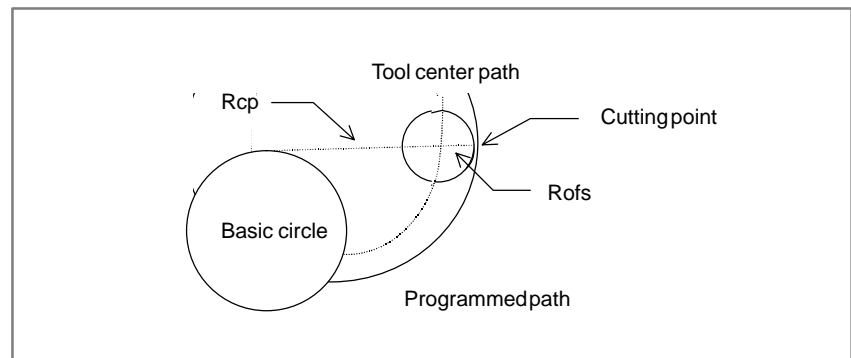

An override value is calculated as follows:

$$\text{OVRa} = \frac{\text{Rcp}}{\text{Rcp} + \text{Rofs}} \times 100$$

Rcp: Curvature radius at the tool center of the involute curve that passes the tool center

Rofs: Tool radius

- **Override in the neighborhood of a basic circle**

If a programmed cutting feedrate is directly used in the neighborhood of a basic circle where the curvature of an involute curve changes relatively sharply, the cutter may be overloaded, resulting in a failure to produce a satisfactory cutting surface. With this function, the movement of the tool is automatically decelerated according to the setting of a parameter in the neighborhood of a basic circle where the curvature of an involute curve changes relatively sharply, so that the load on the cutter is reduced to produce a satisfactory cutting surface.

When the curvature radius at a cutting point reaches a value in the range specified by (Rlmt1) to (Rlmt5), an override is applied as described below.

When $Rlmt1 > Rcp \pm Rofs \geq Rlmt2$

$$OVRb = \frac{100 - OVR2}{Rlmt1 - Rlmt2} \times (Rcp \pm Rofs - Rlmt2) + OVR2$$

When $Rlmt2 > Rcp \pm Rofs \geq Rlmt3$

$$OVRb = \frac{OVR2 - OVR3}{Rlmt2 - Rlmt3} \times (Rcp \pm Rofs - Rlmt3) + OVR3$$

When $Rlmt3 > Rcp \pm Rofs \geq Rlmt4$

$$OVRb = \frac{OVR3 - OVR4}{Rlmt3 - Rlmt4} \times (Rcp \pm Rofs - Rlmt4) + OVR4$$

When $Rlmt4 > Rcp \pm Rofs \geq Rlmt5$

$$OVRb = \frac{OVR4 - OVR5}{Rlmt4 - Rlmt5} \times (Rcp \pm Rofs - Rlmt5) + OVR5$$

Set Rlmt1 through Rlmt5 and OVR2 through OVR5 in parameter No. 5611 through No. 5615 and parameter No. 5616 through No. 5619, respectively. $Rcp \pm Rofs$ should read $Rcp + Rofs$ for inside offsetting, and should read $Rcp - Rofs$ for outside offsetting.

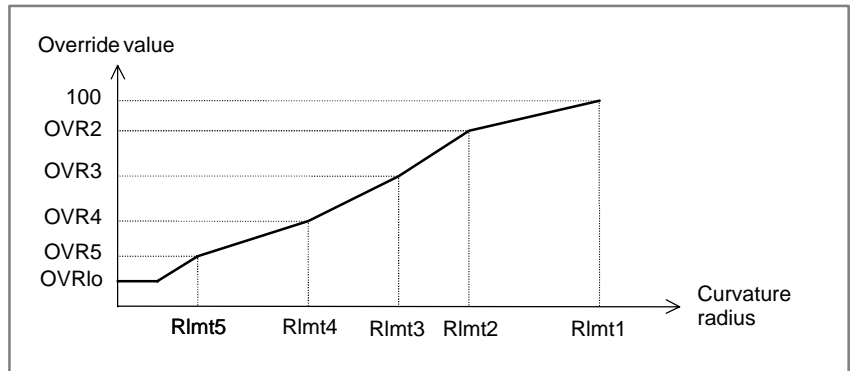

If an override calculation finds an override value that is smaller than the lower limit set in the parameter, the override value is clamped to the lower limit.

NOTE

- 1 When an override in the neighborhood of a basic circle is enabled, an override at the time of cutter compensation inside offsetting is disabled. The two overrides cannot be enabled at the same time.
- 2 When the distance from the center of a basic circle to the start point is the same as the distance from the center of a basic circle to the end point (round circle), circular interpolation is performed. So, automatic overriding is not applied.
- 3 If there is an end point error, a specified feedrate is not guaranteed.
- 4 If there is an end point error, a remaining distance required for acceleration/deceleration before interpolation may not be calculated correctly. In such a case, alarm 242 is issued.
- 5 For other restrictions, refer to the operator's manual.
- 6 When AI nano contour control is used, involute interpolation cannot be specified.

Specifications**Axis control**

○ : Can be programmed

× : Cannot be programmed

Name	Description
Controlled axes	3 to 8 To use four to eight axes, a separate option is required.
Simultaneously controlled axes	Up to 6 To use three simultaneously controlled axes or more, a separate option is required.
Axis name	Basic three axes: Always X, Y, and Z Other axes: U, V, W, A, B, or C
Least input increment	0.001 mm, 0.001 deg, 0.0001 inch
Input increment 1/10	0.0001 mm, 0.0001 deg, 0.00001 inch Specified-axis input increment 1/10 cannot be used.
Simple synchronous control	○ When the AI contour control/nano AI contour control option is usable, however, it is impossible to switch between "to enable synchronization" and "to disable synchronization" during automatic operation (when the automatic-operation-under-way (OP) signal is 1) even when the current mode is not the AI contour control/nano AI contour control mode. If an attempt is made to switch, the PS213 alarm is issued.
Twin table	×
Angular axis/arbitrary angular axis control	×
Tandem control	○ Preloading is impossible.

Name	Description
Chopping	×
Hobbing machine function	×
Simple electric gear box	×
Learning control	×
Preview repetitive control	×
Inch/metric switching (G20, G21)	○ *
Interlock	○
Specified-axis interlock	○ The movement of the tool on all axes is stopped. To stop tool movement on an interlock axis only during positioning of non-linear interpolation type in the AI contour control mode, bit 5 (AIL) of parameter No. 7054 must be set to 1, and bit 4 (XIK) of parameter No. 1002 must be set to 0.
Machine lock	○ If a specified-axis machine lock signal (MLK1 to MLK8) is turned on and off, acceleration/deceleration is not applied to the machine-locked axis.
Pre-movement stroke check	×
Mirror image	○
Stored pitch error compensation	○
Inclination compensation	○
Straightness compensation	○
Position switch	○ Set bit 3 (PSF) of parameter No. 6901 to 1. When this bit is set to 1, the signal output timing changes.
Abnormal load detection	○
Manual handle interrupt	○ (AI contour control) During switching to the AI contour control mode, however, manual handle interrupt is disabled. × (AI nano contour control)
External pulse period	×
Flexible period	×

Interpolation function

○ : Can be programmed

× : Cannot be programmed

Name	Description
Positioning (G00)	○ (Only positioning of linear interpolation type when AI nano contour control is used)
Single direction positioning (G60)	○ To perform single direction positioning in the AI contour control/AI nano contour control mode, bit 4 (ADP) of parameter No. 7055 must be set to 1.

Name	Description
Exact stop (G09)	○
Exact stop mode (G61)	○
Tapping mode (G63)	○
Linear interpolation (G01)	○
Circular interpolation (G02, G03)	○ (Multiple quadrants allowed)
Exponential interpolation (G02.3, G03.3)	×
Dwell (G04)	○ (For a specified number of seconds or revolutions) To specify a number of revolutions for the dwell, the thread cutting/synchronous feed function must be selected.
Polar coordinate interpolation (G12.1, G13.1)	×
Cylindrical interpolation (G07.1)	×
Helical interpolation (G02, G03)	○ (Circular interpolation + Up to four axes for linear interpolation) When the helical interpolation function is selected, up to two axes for linear interpolation can be specified. When the helical interpolation B function is selected, up to four axes for linear interpolation can be specified. A desired feedrate must be specified by also taking movement along the helical axis into consideration.
Involute interpolation (G02.2, G03.2)	○
Hypothetical axis interpolation (G07)	×
Spiral interpolation/Conical interpolation (G02, G03)	○ (AI contour control)
	×
Smooth interpolation (G05.1)	×
Thread cutting/synchronous feed (G33)	×
Skip function (G31)	○ *
High-speed skip function (G31)	○ *
Continuous high-speed skip (G31)	×
Multistage skip function (G31 Px)	○ *
Reference position return (G28)	○ To execute G28 before reference position establishment, bit 2 (ALZ) of parameter No. 7055 must be set to 1. *
Reference position return check (G27)	○ *

Name	Description
2nd, 3rd, and 4th reference position return (G30)	○ *
Floating reference position return (G30.1)	○ *
Normal direction control (G41.1, G42.1)	○ (AI contour control) Bit 2 (ANM) of parameter No. 5484 must be set to 1.
	× (AI nano contour control)
Gentle curve normal direction control	×
Continuous dressing	×
In-feed control (G161)	×
Index table indexing	○ * When the index table indexing axis (fourth axis) is specified for follow-up, bit 7 (NAH4) of parameter No. 1819 and bit 0 (NMI4) of parameter No. 7052 must be set to 1.
High-speed cycle machining (G05)	×
High-speed linear interpolation (G05P2)	×

Feed functions

○ : Can be programmed

× : Cannot be programmed

Name	Description
Rapid traverse rate	Up to 240 m/min (0.01 mm)
	Up to 100 m/min (0.0001 mm)
Rapid traverse rate override	F0, 25, 50, 100 %
Rapid traverse rate override in units of 1%	0% to 100 %
Feed per minute (G94)	○
Feed per rotation (G95)	×
Cutting feedrate clamping	○
Rapid traverse bell-shaped acceleration/deceleration	○
Positioning by optimal acceleration/deceleration	×
Cutting feed linear acceleration/deceleration after interpolation	○
Cutting feed bell-shaped acceleration/deceleration after interpolation	○
Cutting feed linear acceleration/deceleration before interpolation	○ (Look-ahead of 40 blocks maximum/AI contour control) (Look-ahead of 180 blocks maximum/AI nano contour control)

Name	Description
Feedrate override	0% to 254%
Second feedrate override	×
Feed by F command with one digit	× To enable feedrate changing by the manual handle, bit 1 (AF1) of parameter No. 7055 must be set to 1.
Inverse time feed (G93)	○
Override cancel	○
External deceleration	○
Look-ahead bell-shaped acceleration/deceleration before interpolation	○
High-precision contour control (G05P10000)	○
NURBS interpolation (G06.2)	×

Program input

○ : Can be programmed

× : Cannot be programmed

Name	Description
Control in/control out command ()	○
Optional block skip command (/n: n represents a number.)	○
Absolute command (G90)/incremental command (G91)	○
Decimal point input/pocket calculator type decimal point input	○
Input unit tenfold	○
Plane selection (G17, G18, G19)	○
Rotation axis specification	○
Rotation axis rollover	○
Polar coordinates command (G16)	×
Local coordinate system (G52)	○ *
Machine coordinate system (G53)	○ *
Workpiece coordinate system (G54 to G59) (G54.1Pxx)	○
Workpiece coordinate system (G92)	○ *
Workpiece coordinate system preset (G92.1)	○ *
Arbitrary angle chamfering/corner rounding	×

Name	Description
Programmable data input (G10)	○ * Only the tool offset value, workpiece origin offset, and parameter can be modified.
Custom macro B	○ See the item of notes on using custom macros.
Custom macro common variable addition	○
Pattern data input	×
Interrupt-type custom macro	×
Canned cycle (G73 to G89)	○ *
Initial level return (G98)/R point level return (G99)	○ *
Small-hole peck drilling cycle (G83)	×
Arc radius R specification	○
Automatic corner override (G62)	○ Bit 0 (ACO) of parameter No. 7055 must be set to 1.
Automatic corner deceleration	○
Feedrate clamping based on arc radius	○
Scaling (G51)	○
Coordinate system rotation (G68)	○
Three-dimensional coordinate conversion (G68)	×
Programmable mirror image (G51.1)	○
Figure copy (G72.1, G72.2)	×
Retrace	×
F15 tape format	○

Auxiliary functions/spindle functions

○ : Can be programmed

× : Cannot be programmed

Name	Description
Miscellaneous function (Mxxxx)	○ Only the output of the function code signal and function strobe signal is performed.
Second auxiliary function (Bxxxx)	○ Only the output of the function code signal and function strobe signal is performed.
High-speed M/S/T/B interface	○ Specification of multiple auxiliary functions
M code group check	○
Spindle function (Sxxxx)	○
Spindle synchronization	○

Name	Description
Simple spindle synchronization	○
Rigid tapping	○ * Bit 5 (G8S) of parameter No. 1602 or bit 3 (ACR) of parameter No. 7051 must be set to 1. (AI contour control)
	○ * Bit 3 (ACR) of parameter No. 7051 must be set to 1. (AI nano contour control)
Three-dimensional rigid tapping	×

Tool compensation functions

○ : Can be programmed

× : Cannot be programmed

Name	Description
Tool function (Txxxx)	○ Only the output of the function code signal and function strobe signal is performed.
Tool offset memory B	○
Tool offset memory C	○
Tool length compensation (G43, G44, G49)	○
Tool offset (G45 to G48)	×
Cutter compensation B (G39 to G42)	×
Cutter compensation C (G40, G41, G42)	○
Three-dimensional tool compensation	×
Tool life management	×
Automatic tool length measurement	×
Tool length workpiece origin measurement B	×
Grinding-wheel wear compensation	×

Others

○ : Can be programmed

× : Cannot be programmed

Name	Description
Cycle start/Feed hold	○
Dry run	○
Single block	○
Sequence number check stop	○

Name	Description
Program restart	<p>○ As an acceleration/deceleration time constant for movement to a restart position, the following parameters are used: When exponential acceleration/deceleration is used: Parameter No. 1624 and No. 1625 When linear/bell-shaped acceleration/deceleration is used: Parameter No. 1622. For switching between the acceleration/deceleration types, bits 0 and 1 of parameter No. 1610 are used.</p>
Tool retraction and return	×
Return in rigid tapping	×
Macro executor (execution macro)	×
MDI operation	○
Manual intervention	○

NOTE

- 1 For some functions to be specified, separate options need to be set.
- 2 Those functions marked with an asterisk (*) do not perform look-ahead control of multiple blocks.

**Conditions for entering
AI contour control mode**

Before G05.1 Q1, the following modal codes must be specified. If this condition is not satisfied, P/S alarm No. 5111 will be issued.

G code	Description
G00	Positioning
G01	Linear interpolation
G02	Circular interpolation (CW)
G03	Circular interpolation (CCW)
G13.1	Polar coordinate interpolation cancel mode
G15	Polar coordinate command cancel
G25	Spindle speed fluctuation detection off
G40	Cutter compensation cancel
G40.1	Normal direction control cancel mode
G49	Tool length compensation cancel
G50	Scaling cancel
G50.1	Programmable mirror image cancel
G64	Cutting mode
G67	Macro modal call cancel
G69	Coordinate rotation cancel
G80	Canned cycle cancel
G94	Feed per minute
G97	Constant surface speed control cancel
G160	In-feed control function cancel

Signal**AI contour control or AI
nano contour control
mode signal AICC
<F062#0>**

[Classification] Output signal

[Function] This signal indicates that the system is in AI contour control or AI nano contour control mode.

[Output condition] The signal is set to 1 when:

- The system is in AI contour control or AI nano contour control mode.

The signal is set to 0 when:

- The system is in other than AI contour control or AI nano contour control mode.

Signal address

	#7	#6	#5	#4	#3	#2	#1	#0
F062								AICC

Parameter

- **Parameters related to linear acceleration/deceleration before interpolation**

1770	Maximum machining feedrate during linear acceleration/deceleration before interpolation
------	---

[Data type] 2-word

[Unit of data] [Valid data range]	Increment system	Unit of data	Valid data range	
			IS-A, IS-B	IS-C
	Millimeter machine	1 mm/min	6 to 240000	6 to 100000
	Inch machine	0.01 inch/min	6 to 9600	6 to 4800

This parameter sets the maximum machining feedrate for linear acceleration/deceleration before interpolation. (Parameter 1 for setting the acceleration in linear acceleration/deceleration before interpolation)

1771	Time required to reach the maximum machining feedrate during linear acceleration/deceleration before interpolation (time constant)
------	--

[Data type] Word

[Unit of data] 1 ms

[Valid data range] 0 to 4000

This parameter sets the time (time constant) required to reach the feedrate set in parameter 1. (Parameter 2 for setting the acceleration in linear acceleration/deceleration before interpolation)

NOTE

- 1 When parameter 1770 or 1771 is set to 0, linear acceleration/deceleration before interpolation is not performed.
- 2 Set these parameters so that parameter 1770/parameter 1771 = 5 or more.

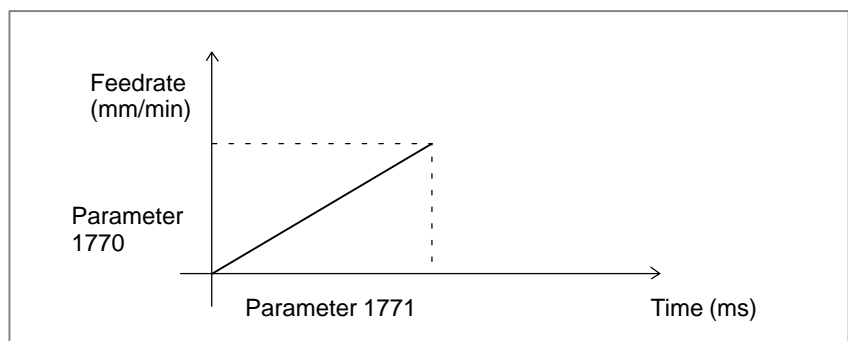

1784	Speed when an overtravel alarm is issued during linear acceleration/deceleration before interpolation
------	---

[Data type] Word

[Unit of data] [Valid data range]	Increment system	Unit of data	Valid data range	
			IS-A, IS-B	IS-C
	Millimeter machine	1 mm/min	6 to 15000	6 to 12000
	Inch machine	0.01 inch/min	6 to 6000	6 to 4800

This parameter sets the speed to be reached when an overtravel alarm is issued during linear acceleration/deceleration during interpolation. If an overtravel alarm is issued during linear acceleration/deceleration before interpolation, the movement is decelerated and halted after the issue of the alarm. Therefore, the tool overruns by an amount equal to the distance traveled during deceleration. The overrun varies depending on the feedrate observed when the overtravel alarm is issued. The overrun can be reduced by performing deceleration to the speed set in parameter 1784 in advance when an overtravel alarm is issued. In this case, deceleration is performed so that the feedrate at the instant when the overtravel alarm is issued does not exceed the parameter-set speed. So, deceleration may be completed earlier. Upon the completion of deceleration, the feedrate is set to the parameter-set speed.

NOTE
This parameter is invalid for rapid traverse blocks.

If the following condition is satisfied, deceleration is performed:

Distance to the stored stroke limit on an axis	<	Distance required for decelerating the current speed (tangent direction feedrate) to the speed set in parameter 1784
--	---	--

The overrun is expressed as follows:

$$\text{Overrun distance} \cong \frac{\left[\text{FIX} \left(\frac{F_{OT}}{F} \times \frac{T}{8} \right) + 1.5 \right]^2}{1875} \times \frac{F}{T}$$

F : Maximum machining feedrate during linear acceleration/deceleration before interpolation (parameter 1770)

T : Time required to reach the maximum machining feedrate during linear acceleration/deceleration before interpolation (parameter 1771)

F_{OT} : Speed when an overtravel alarm is issued during linear acceleration/deceleration before interpolation (parameter 1784)

FIX : Any fractional part is truncated.

NOTE

- 1 When 0 is set, the above control is not performed.
- 2 When stroke check is invalid, the above control is also invalid.
- 3 The above control is valid only for stored stroke check 1.
- 4 The above control is exercised on those axes that are specified in the current block and the next block.

● **Parameter related to automatic corner deceleration**

1783 Allowablefeedrate difference for each axis in the corner deceleration function by feedrate difference (for acceleration/deceleration before interpolation)

[Data type] Word axis

[Unit of data]

[Valid data range]

Increment system	Unit of data	Valid data range	
		IS-A, IS-B	IS-C
Millimeter machine	1 mm/min	6 to 15000	6 to 12000
Inch machine	0.1 inch/min	6 to 6000	6 to 4800
Rotation axis	1 deg/min	6 to 15000	6 to 12000

This parameter sets the allowable difference in feedrate on each axis in the automatic corner deceleration function by the difference in feedrate when liner acceleration/deceleration before interpolation is used.

● **Parameter related to feedrate clamping by acceleration**

1785 Parameter for determining the allowable acceleration in feedrate clamping by acceleration

[Data type] Word axis

[Unit of data] 1 ms

[Valid data range] 0 to 32767

This parameter is used to set the time required to reach the maximum cutting feedrate and determine the allowable acceleration when feedrate clamping by acceleration is performed.

The allowable acceleration is determined from the maximum cutting feedrate and the data set in this parameter. Parameter 1432 (maximum cutting feedrate in AI contour control or AI nano contour control mode) is used as the maximum cutting feedrate.

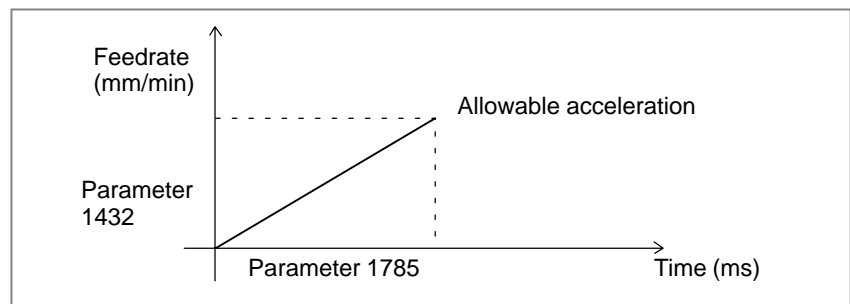

● Parameters related to feedrate clamping by arc radius

1731 Arc radius for the upper limit imposed on feedrate

[Data type] 2-word

[Unit of data]	Increment system	IS-A	IS-B	IS-C	Unit
	Metric input	0.01	0.001	0.0001	mm
	Inch input	0.001	0.0001	0.00001	inch

[Valid data range] 1000 to 99999999

This parameter sets the arc radius for the upper limit imposed on the feedrate set in parameter 1730.

1730 Upper limit imposed on feedrate for arc radius R

[Data type] Word

[Unit of data]	Increment system	Unit of data	Valid data range	
			IS-A, IS-B	IS-C
[Valid data range]	Millimeter machine	1 mm/min	8 to 15000	8 to 12000
	Inch machine	0.1 inch/min	8 to 6000	8 to 4800

This parameter sets the upper limit imposed on the feed rate for the arc radius set in parameter 1731.

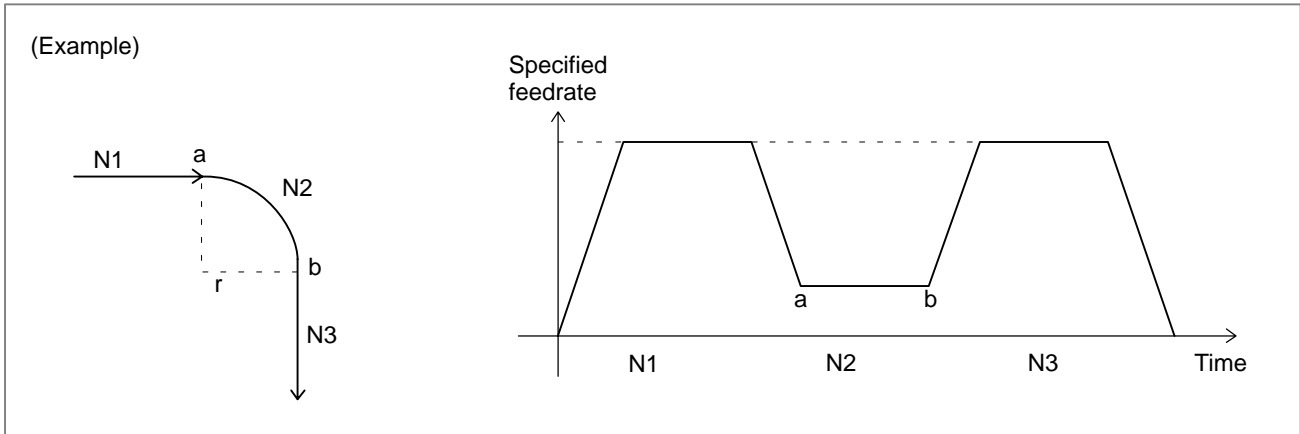

1732 Lower limit RVmin for feedrate clamping by arc radius

[Data type] Word

[Unit of data]	Increment system	Unit of data	Valid data range	
			IS-A, IS-B	IS-C
[Valid data range]	Millimeter machine	1 mm/min	0 to 15000	0 to 12000
	Inch machine	0.1 inch/min	0 to 6000	0 to 4800

When the function for clamping the feedrate by arc radius is used, the upper limit imposed on the feedrate falls with the arc radius. If the upper limit imposed on the feedrate is less than the lower limit imposed on the feedrate clamping RVmin, the upper limit imposed on the feedrate is set as RVmin.

● **Involute interpolation**

5611	Radius of curvature at cutting point for starting basic circle neighborhood override 1 (Rlmt1)
5612	Radius of curvature at cutting point for starting basic circle neighborhood override 2 (Rlmt2)
5613	Radius of curvature at cutting point for starting basic circle neighborhood override 3 (Rlmt3)
5614	Radius of curvature at cutting point for starting basic circle neighborhood override 4 (Rlmt4)
5615	Radius of curvature at cutting point for starting basic circle neighborhood override 5 (Rlmt5)

[Data type] Two-word

[Unit of data]	Increment system	IS-A	IS-B	IS-C	Unit
	Millimeter machine	0.01	0.001	0.0001	mm
	Inch machine	0.001	0.0001	0.00001	inch

[Valid data range] 0 to 99999999

5616	Override value for starting basic circle neighborhood override 2 (OVR2)
5617	Override value for starting basic circle neighborhood override 3 (OVR3)
5618	Override value for starting basic circle neighborhood override 4 (OVR4)
5619	Override value for starting basic circle neighborhood override 5 (OVR5)
5620	Lower override limit during involute interpolation (OVRlo)

[Data type] Byte

[Unit of data] 1%

[Valid data range] 0 to 100

Set Rlmt1 through Rlmt5 and OVR2 through OVR5 shown in the figure below for overrides in the neighborhood of a basic circle.

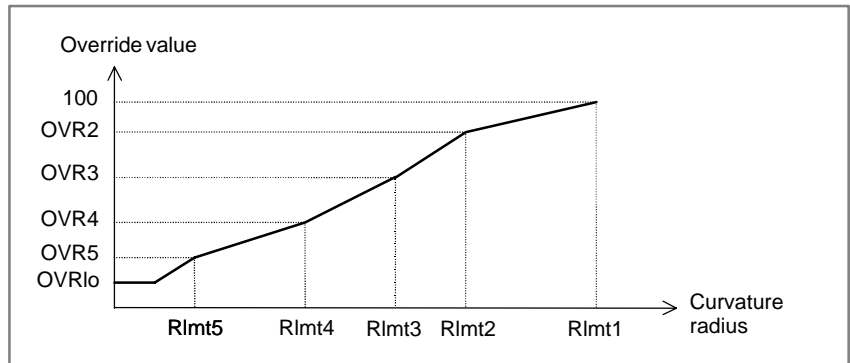

The curvature radiuses Rlmt1 through Rlmt5 and the override values OVR2 through OVR5 must have the relationships indicated below. If the following relationships are not satisfied, overrides in the neighborhood of a basic circle are disabled:

$$Rlmt1 > Rlmt2 > Rlmt3 > Rlmt4 > Rlmt5 > 0$$

$$100 > OVR2 > OVR3 > OVR4 > OVR5 > 0$$

If the lower override limit (OVR1o) is 0 during involute interpolation, overrides for cutter compensation inside offsets and the neighborhood of a basic circle are disabled.

• Other parameters

1422	Upper limit imposed on cutting feedrate in AI contour control or AI nano contour control
------	--

[Data type] 2-word

[Unit of data]	Increment system	Unit of data	Valid data range	
[Valid data range]			IS-A, IS-B	IS-C
	Millimeter machine	1 mm/min	6 to 240000	6 to 100000
	Inch machine	0.1 inch/min	6 to 96000	6 to 4800

This parameter is used to set the upper limit on the cutting feedrate in AI contour control or AI nano contour control mode.

1432	Maximum cutting feedrate in AI contour control mode (for each axis)
------	---

[Data type] 2-word axis

[Unit of data]	Increment system	Unit of data	Valid data range	
[Valid data range]			IS-A, IS-B	IS-C
	Millimeter machine	1 mm/min	0 to 240000	0 to 100000
	Inch machine	0.1 inch/min	0 to 96000	0 to 48000
	Rotation axis	1 deg/min	0 to 240000	0 to 100000

This parameter sets the maximum cutting feedrate for each axis in AI contour control or AI nano contour control mode.

NOTE
Be sure to set a maximum cutting feedrate in both of parameter No. 1422 and No. 1432.

	#7	#6	#5	#4	#3	#2	#1	#0
1603	BEL	RBL						

[Data type] Bit

RBL In the AI contour control mode or AI nano contour control, acceleration/deceleration of rapid traverse is:
 0: Linear acceleration/deceleration.
 1: Bell-shaped acceleration/deceleration.

NOTE

To select bell-shaped acceleration/deceleration, the option for rapid traverse bell-shaped acceleration/deceleration is required.

- BEL** In AI contour control mode or AI nano contour control:
- 0 : Linear acceleration/deceleration before look-ahead interpolation is used.
 - 1 : Bell-shaped acceleration/deceleration before look-ahead interpolation is used.

NOTE

To select look-ahead bell-shaped acceleration/deceleration before interpolation, the option for look-ahead bell-shaped acceleration/deceleration before interpolation is required.

1621	Time constant for axis-by-axis rapid traverse bell-shaped acceleration/deceleration
------	---

[Data type] Word axis

[Unit of data] 1 ms

[Valid data range] 0 to 512

Set t_b in the figure below for each axis. When 0 is set, linear acceleration/deceleration is assumed.

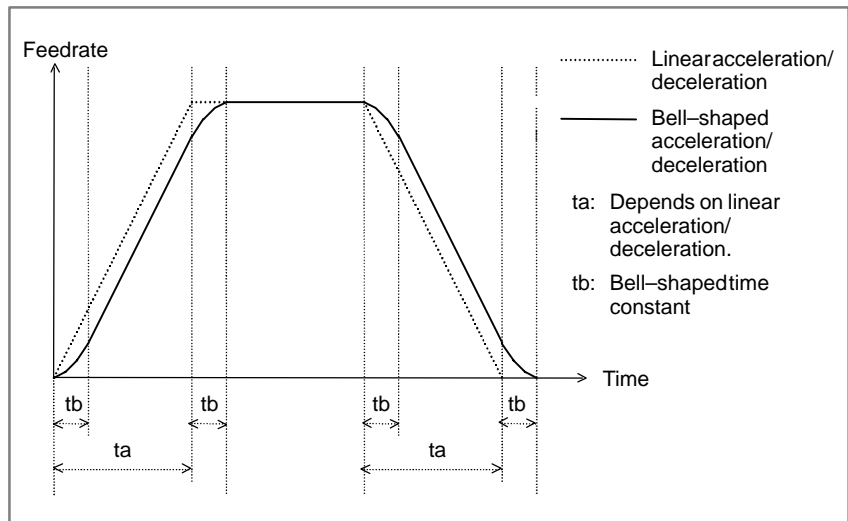

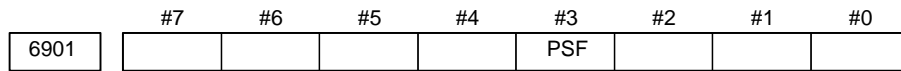

[Data type] Bit

PSF In high-precision contour control mode (M series), AI contour control mode (M series), AI nano-contour control mode (M series), or advanced preview control mode, position switches are:
 0 : Not used.
 1 : Used.

NOTE

1 The position switch signals are output considering acceleration/deceleration after interpolation and servo delay. Acceleration/deceleration after interpolation and servo delay are considered even for position switch signal output in a mode other than the high-precision contour control (M series), AI contour control (M series), AI nano contour control (M series), and advanced preview control modes. When this parameter is set to 1, however, signals are output from the position switches at different times from the specified ones.

2 When using the high-speed position switch of decision-by-direction type, set bit 1 (HPE) of parameter No. 8501 to 0 (to consider a servo delay amount for decision of direction).

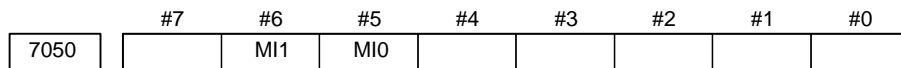

[Data type] Bit

MI1, MI0 Set the following values

	MI1	MI0
Setting	0	1

NOTE
 This parameter is valid only with AI contour control. This parameter need not be set with AI nano contour control.

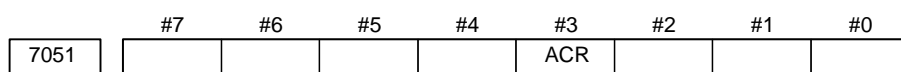

[Data type] Bit

ACR When rigid tapping is specified in AI contour control mode or AI nano contour control mode, the mode is:
 0 : Not turned off.
 1 : Turned off.

When the serial spindle does not support advanced preview control of rigid tapping, AI contour control mode or AI nano contour control mode must be turned off in rigid tapping.

Setting this parameter and satisfying the following conditions can automatically turn AI contour control mode or AI nano contour control mode off only during execution of rigid tapping when rigid tapping is specified in AI contour control mode or AI nano contour control mode.

Conditions

- To specify rigid mode, use “the method for specifying M29 S**** prior to the tapping command.”
If a method other than the above is used, P/S alarm No. 5110 is issued.
- The interval between M29 (rigid mode specification M code) and the completion signal (FIN) must be at least 32 msec.
- The rigid mode cancel command and cutting feed move command cannot be specified simultaneously. If they are specified simultaneously, P/S alarm No. 5110 is issued.
(Additional information: The rigid mode cancel command and rapid traverse move command can be specified in the same block.)
- Set bit 2 (CRG) of parameter No. 5200 to 0.
(This setting specifies that rigid tapping mode is canceled when the rigid tapping signal RGTAP is set to “0”.)

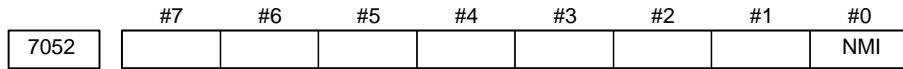

[Data type] Bit axis

For the PMC-controlled axes and Cs axis, set 1.
Set this bit to 1 for the index table indexing axis (fourth axis) set for follow-up.
Set this bit to 0 when using the servo FAD function.

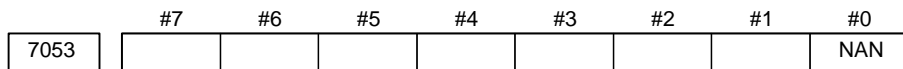

[Data type] Bit

NAN G5.1Q1 specifies:
0 : AI nano-contour control
1 : AI contour control

NOTE
This parameter is valid when the option for AI nano contour control is selected.

	#7	#6	#5	#4	#3	#2	#1	#0
7054			AIL		AZR		AIR	HPL

[Data type] Bit

HPL If HPCC mode is specified in AI contour control mode or AI nano contour control mode and a command unavailable in HPCC mode is found, the NC processes the command:

0 : In normal mode.

1 : In AI contour control mode or AI nano contour control mode.

AIR In AI contour control mode, the rapid traverse type is:

0 : Linear interpolation type.

1 : According to the setting of bit 1 (LRP) of parameter No. 1401.

NOTE

The setting of 1 is valid only for AI contour control. For AI nano contour control, set this bit to 0.

AZR In AI contour control mode, the G27, G28, G30, G30.1, and G53 commands are executed:

0 : In normal mode. (advanced preview feed forward is valid.)

1 : In AI contour control mode.

NOTE

When G27, G28, G30, G30.1, or G53 is executed when AI contour control is on, a choice between linear interpolation type and non-linear interpolation type can be made by parameter setting.

However, while G28, G30, G30.1, or G53 is being executed with linear interpolation type selected, automatic operation cannot be restarted at a position other than the stop position through manual intervention. If such an attempt is made, an alarm (No. 5114) is issued.

AI contour control	Bit 1 (AIR) of parameter No. 7054	Bit 1 (LRP) of parameter No. 1401	G27, G28, G30, G30.1, G53	G00
Off	0	0	Non-linear interpolation type	Non-linear interpolation type
	0	1	Non-linear interpolation type	Linear interpolation type
	1	0	Non-linear interpolation type	Non-linear interpolation type
	1	1	Non-linear interpolation type	Linear interpolation type
On	0	0	Linear interpolation type	Linear interpolation type
	0	1	Linear interpolation type	Linear interpolation type
	1	0	Non-linear interpolation type	Non-linear interpolation type
	1	1	Linear interpolation type	Linear interpolation type

NOTE

- 1 When an index table indexing axis is specified, G27, G28, G30, G30.1, or G53 is executed with AI contour control turned off, regardless of the setting of bit 3 (AZR) of parameter No. 7054.
- 2 When G27, G28, G30, G30.1, or G53 is executed with AI contour control turned on, positioning based on maximum acceleration/deceleration is disabled.
- 3 This parameter is valid only with AI contour control.
When AI nano contour control is used, set 0 in this parameter.

- AIL** When non-linear type positioning is specified in AI contour control mode and an axis-by-axis interlock signal is input:
0 : The tool stops along all axes.
1 : The setting of bit 4 (XIF) of parameter No. 1002 is used.

NOTE

This parameter is valid only with AI contour control.

	#7	#6	#5	#4	#3	#2	#1	#0
7055				ADP		ALZ	AF1	ACO

[Data type] Bit

- ACO** In AI contour control mode or AI nano contour control mode:
0 : Automatic corner override and changing both internal and external circular feedrates are disabled.
1 : Automatic corner override and changing the internal circular feedrate are enabled, and whether to enable changing the external circular feedrate depends on the setting of bit 2 (COV) of parameter No. 1602.
- AF1** During one-digit F code feed in AI contour control mode or AI nano contour control mode, changing the feedrate by the manual handle is:
0 : Disabled.
1 : Enabled.
- ALZ** If no reference position has been established and G28 is specified in AI contour control mode or AI nano contour control mode:
0 : P/S alarm No. 090 is issued.
1 : AI contour control mode or AI nano contour control mode is turned off and the command is executed.

NOTE

- 1 If an axis for which a reference position is established and an axis for which no reference position is established are simultaneously specified with G28 when bit 2 (ALZ) of parameter No. 7055 is set to 1, G28 is executed after turning off the AI contour control/AI nano contour control mode, regardless of the setting of bit 3 (AZR) of parameter No. 7054.
- 2 If the serial spindle is switched to the Cs contour control mode then G00 is specified for the Cs contour control axis without performing a reference position return operation even once during AI contour control/AI nano contour control when bit 1 (NRF) of parameter No. 3700 is set to 0, a P/S alarm (No. 090) is issued, regardless of the setting of bit 2 (ALZ) of parameter No. 7055.

ADP Single direction positioning in the AI contour control/AI nano contour control mode is executed:

0 : In the normal mode.

1 : In the AI contour control/AI nano contour control mode.

3241	Character blinking in the AI contour control mode (first character)
to	
3247	Character blinking in the AI contour control mode (seventh character)

[Data type] Byte

[Valid data range] -128 to 127

Set the character codes of characters blinking in the AI contour control mode.

Set character codes according to the character code list in Appendix A.

NOTE

When 0 is set, AICC blinks.

3251	Character blinking in the AI nano contour control mode (first character)
to	
3257	Character blinking in the AI nano contour control mode (seventh character)

[Data type] Byte

[Valid data range] -128 to 127

Set the character codes of characters blinking in the AI nano contour control mode.

Set character codes according to the character code list in Appendix A.

NOTE

When 0 is set, AI NANO blinks.

- **Parameter numbers in standard mode, advanced preview control mode, AI contour control mode, and AI nano contour control mode**

(In the tables below, the AI contour control mode and AI nano contour control mode are referred to as AI contour control.)

(1) Parameters related to linear acceleration/deceleration before interpolation

Parameter	Parameter No.		
	Standard mode	Advanced preview control	AI contour control
Acceleration/deceleration type (type A/B)	FWB/1602#0		None
Parameter 1 for setting acceleration	1630	1770	
Parameter 2 for setting acceleration	1631	1771	
Speed when overtravel alarm is issued	1784		

(2) Parameters related to automatic corner deceleration

Parameter	Parameter No.		
	Standard mode	Advanced preview control	AI contour control
Method for determining automatic corner deceleration (angle/feedrate difference)	CSD/1602#4		None
Lower limit imposed on feedrate (control based on angle)	1778	1777	None
Angle to be determined (control based on angle)	1740	1779	None
Allowable feedrate difference for all axes (control based on feedrate difference)	1780		None
Allowable feedrate difference for each axis (control based on feedrate difference)	1783		

(3) Parameters related to feedrate clamping by acceleration/deceleration

Parameter	Parameter No.		
	Standard mode	Advanced preview control	AI contour control
Parameter for determining acceleration/deceleration	None		1785

(4) Parameters related to feedrate clamping by arc radius

Parameter	Parameter No.		
	Standard mode	Advanced preview control	AI contour control
Arc radius for the upper limit of feedrate	1731		
Upper limit imposed on feedrate for arc radius R	1730		
Lower limit imposed on clamp feedrate	1732		

(5) Parameters related to involute interpolation

Parameter	Parameter No.		
	Standard mode	Advanced preview control	AI contour control
Initial angle error limit	5610		
Basic circle neighborhood override: Radius of curvature	None		5611 to 5615
Basic circle neighborhood override: Override value	None		5616 to 5619
Lower override limit	None		5620

(6) Other parameters

Parameter	Parameter No.		
	Standard mode	Advanced preview control	AI contour control
Precision of radius error in circular interpolation	PCIR1/3403#0		None
Maximum cutting feedrate (for all axes)	1422	1431	1422
Maximum cutting feedrate (for each axis)	1430	1432	
Rapid traverse type(*1)	LRP/1402#1		AIR/7054#1 LRP/1401#1
Rapid traverse bell-shaped acceleration/deceleration time constant	1621		

*1 When AI nano contour control is used, the rapid traverse type is positioning of linear interpolation type at all times, regardless of parameter setting.

Alarm and message

Number	Message	Description
5110	IMPROPER G-CODE (G05.1 G1 MODE)	An invalid G code is specified in AI contour control mode or AI nano contour control mode. A command is specified for the index table indexing axis in simple high-precision contour control mode.
5111	IMPROPER MODAL G-CODE (G05.1 G1)	When AI contour control mode or AI nano contour control mode is specified, a G code that cannot be used is placed in the modal state.
5112	G08 CAN NOT BE COMMANDED (G05.1 G1)	An advanced preview control command (G08) is specified in AI contour control mode or AI nano contour control mode.
5114	NOT STOP POSITION (G05.1 Q1)	Upon a restart after manual intervention, the coordinates at which manual intervention was performed are not restored.
5156	SPL: ERROR	The controlled axis selection signal (PMC axis control) changes in AI contour control mode or AI nano contour control mode. The simple synchronous axis selection signal changes in simple high-precision contour control mode.
5157	Feedrate 0 (AICC)	The parameter for the maximum cutting feedrate (parameter No. 1422 or 1432) is set to 0. The parameter for acceleration/deceleration before interpolation (parameter No. 1770 or 1771) is set to 0.

Caution

- 1 This function requires the option for the AI contour control function or for the AI nano contour control function.
When the option for the AI contour control function is specified, the advanced preview control function (G08P1) can be specified. When the option for the AI nano contour control is specified, the AI contour control function and the advanced preview control function (G08P1) can be specified.
- 2 When the total distance for the blocks under advanced preview control is equal to or less than the deceleration distance from the current feedrate, deceleration starts. When advanced preview control has proceeded upon the completion of deceleration, and the total distance for the blocks increases, acceleration starts. Especially, when a series of blocks containing very small amounts of travel are specified, deceleration and acceleration may be alternated, which prevents the feedrate from becoming constant. In such a case, specify a lower feedrate.

- 3 When the dry run signal is inverted from 0 to 1 or from 1 to 0 during movement along an axis, the speed of movement is increased or reduced to a specified speed without first being reduced to zero.
- 4 When a no-movement block or a one-shot G code such as G04 is encountered in AI contour control or AI nano contour control mode, the movement is decelerated and halted in the preceding block.
- 5 As acceleration after interpolation, use linear or bell-shaped acceleration. Exponential acceleration/deceleration cannot be used.

Notes on using custom macros

Macro statement processing

For smooth machining, the CNC reads the next NC statement in advance. This operation is referred to as buffering. In the AI contour control/AI nano contour control mode, not only the next statement but also multiple blocks are buffered.

However, a macro statement such as an expression and conditional branch is processed immediately after it is buffered (read into the buffer). So, the timing of macro statement execution does not necessarily follow the specified sequence.

On the contrary, a block where M00, M01, M02, M30, or an M code set in a parameter (No. 3411 to 3432) for suppressing buffering is specified, or a block where a G code such as G53 for suppressing buffering is specified does not read subsequent blocks in advance. So, it is guaranteed that until the execution of such an M code or G code is completed, no subsequent macro statement is executed.

Details of NC statement and macro statement execution

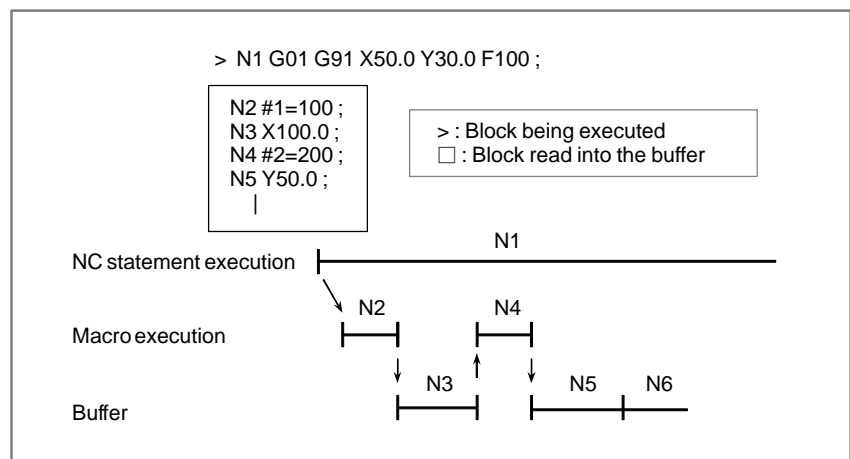

In the AI contour control/AI nano contour control mode, multiple blocks are read in advance. So, during execution of N1, up to 40/180 blocks of NC statements are read into the buffer. The macro statements (N2, N4) are processed while N1 is being executed.

So, the sequence of NC statement and macro statement execution differs from the programmed sequence.

Notes on using system variables

When a system variable listed in the table below is used in a macro program, and the macro program needs to be executed after the block immediately preceding the macro program is executed, an M code (parameter No. 3411 to No. 3432) for suppressing buffering or G53 must be inserted immediately before the macro program.

Meaning	Read/write	Variable number	Remarks (when buffering is not suppressed)
Interface signal	Read	#1000 to #1015, #1032	Data can be read when a macro is buffered.
	Write	#1100 to #1115, #1132	Data is written when a macro is buffered.
Tool offset value	Write	#10000 to	A tool offset value is written when a macro is buffered.
Time information	Read	#3001, #3002, #3011, #3004	Time information is read when a macro is buffered.
Automatic operation control	Write	#3003, #3004	Automatic operation control is enabled starting with up to the third block ahead.
Setting data	Write	#3005	Setting data is written when a macro is buffered.
Mirror image	Read	#3007	Mirror image state can be read when a macro is buffered.
Additional workpiece coordinate system number currently selected	Read	#4130(P) #4014 (G54 to G59)	The information of up to 3 blocks ahead can be read.
Block end (workpiece coordinate system)	Read	#5001 to #5008	The block end of up to the third block ahead can be read.
Machine coordinate system	Read	#5021 to #5028	An undefined position during travel can be read.
Current position (workpiece coordinate system)	Read	#5041 to #5048	An undefined position during travel can be read.
Tool length compensation value	Read	#5081 to #5088	The compensation value used by the block currently being executed can be read.
Servo positional deviation amount	Read	#5101 to #5108	An undefined positional deviation amount during travel can be read.

Example)

```

O0001
N1 X10.Y10.;
N2 M98P2000;
N3 Y200.0;
:
:
M99;
O2000
(Mxx;) Inserts an M code block for suppressing
buffering.
N100 #1=#5041; (Reads the current position
along the X-axis.)
N101 #2=#5042; (Read the current position
along the Y-axis.)
:
:
M99;

```

In the example above, while the N1 block of the main program O0001 is being executed, the N2 block is buffered, and the macro program O2000 is read and executed. This means that the current position is read during travel along the axes in the N1 block. So, undefined position information during travel is read into #1 and #2. In such a case, insert a block specifying an M code (Mxx;) for suppressing buffering or G53; immediately before the N100 block of O2000. With this block insertion, the execution of O2000 starts when the execution of the N1 block of O0001 is completed. So, position information after the completion of execution of the N1 block can be read into #1 and #2.

Reference item

Series 16i/160i/18i/180i	OPERATOR'S MANUAL (For Machining Center) (B-63534EN)	II.19.7	AI contour control/AI nano con- tour control
Series 20i	OPERATOR'S MANUAL (For Manual Milling Machine) (B-64204EN)	II.17.3	AI contour control (G05.1)
Connection manual (This function)		7.1.19	RISC Processor Operation

7.1.17 AI Advanced Preview Control (M Series)

General

The AI advanced preview control function is provided for high-speed, high-precision machining like the AI contour control function described above. This function enables suppression of acceleration/deceleration delays and servo delays that become larger with increases in the feedrate and reduction of machining profile errors.

This function also enables look-ahead linear acceleration/deceleration before interpolation for up to 15 blocks to execute smooth acceleration/deceleration extending over multiple blocks and higher machining.

Format

```
G05.1 Q_ ;
      Q1: AI advanced preview control mode on
      Q0: AI advanced preview control mode off
```

NOTE
 1 Always specify G05.1 in an independent block.
 2 AI advanced preview control mode is also canceled by a reset.

Functions valid in AI advanced preview control mode

- (1) Look-ahead linear acceleration/deceleration before interpolation (for up to 15 blocks)
- (2) Automatic corner deceleration
- (3) Feedrate clamping by acceleration
- (4) Feedrate clamping by arc radius
- (5) Block overlap (five blocks)
- (6) Advanced feed forward

For details of each function, see the subsection describing AI contour control.

NOTE
 1 The following restrictions are imposed on AI advanced preview control (they are not imposed on AI contour control).
 • Up to 15 blocks can be read in advance.
 • Look-ahead bell-shaped acceleration/deceleration before interpolation cannot be used.
 2 Some described functions other than the above may be unavailable for the Series 21i-M. For whether each function is available for the Series 21i-M, refer to the descriptions and other manuals.

Signal

See the description of "Signal" in the subsection describing AI contour control.

Parameter

3241	Blinking character in AI advanced preview control mode (first character)
:	:
3247	Blinking character in AI advanced preview control mode (seventh character)

[Data type] Byte

Set the character code of each blinking character in AI advanced preview control mode. For the setting, refer to the character-code correspondence table in the operator's manual.

NOTE

When a value of "0" is set as the character code, "AI APC" blinks.

For other parameters, see the description of "Parameter" in the subsection describing AI contour control.

NOTE

- 1 Some parameters of functions unavailable for the Series 21i-M may be described. For whether each function is available for the Series 21i-M, refer to the descriptions and other manuals.
- 2 For AI advanced preview control, bits 5 (MI0) and 6 (MI1) of parameter No. 7050 and bit 0 (NMI) of parameter No. 7052 do not need to be set.

Alarm and message

See the description of "Alarm and message" in the subsection describing AI contour control.

Caution

See the description of "Caution" and "Notes on using custom macros" in the subsection describing AI contour control.

7.1.18 AI High-precision Contour Control/AI Nano High-precision Contour Control (M Series)

General

The AI high-precision contour control function is provided for high-speed, high-precision machining such as metal die machining in programs containing continuous minute straight lines and NURBS curve commands. This function enables suppression of acceleration/deceleration delays and servo delays that become larger with increases in the feedrate.

This function can be used to make the tool follow the specified values faithfully, reducing machining profile errors and executing high-speed, high-precision machining.

The function can perform finer acceleration/deceleration than conventional high-precision contour control to increase the machining speed.

AI nano high-precision contour control allows nano-interpolation to be used together with all functions of AI high-precision contour control.

The detection unit is normally used as the unit for output from the NC to the servo system. The nano-interpolation function can perform output to the servo system in thousandths of the detection unit to increase the machining precision. This function is effective in improvement in surface roughness in particular.

The positioning precision differs depends on the machine conditions such as the resolution of the detector, however.

This function is the most effective when the resolution of the detector is smaller than the detection unit. It may also be effective when the resolution of the detector is the same as the detection unit (in a case such as a closed loop). In this case, the feed-forward function is required to be used together.

The AI nano high-precision contour control function is the same as the AI high-precision contour control function except that nano-interpolation is available. The following describes only AI high-precision contour control.

RISC processor is necessary, if this function is used. Refer to Subsection 7.1.19 "RISC Processor Operation," in this manual too.

Format

The following command can be used to turn AI high-precision contour control mode on or off.

In AI high-precision contour control mode, "AI HPCC" blinks at the lower right of the screen.

In AI nano high-precision contour control mode, "NANO HP" blinks.

G05 P10000 : AI high-precision contour control mode on
G05 P0 : AI high-precision contour control mode off
Specify G05 in an independent block.

Valid functions

In AI high-precision contour control mode, the following functions are valid. High-speed, high-precision machining can be performed for minute straight lines and curves such as those made by NURBS interpolation.

- <1> Linear or bell-shaped acceleration/deceleration before interpolation function (constant acceleration change time type)
- <2> Function of decelerating according to the feedrate difference at each corner
- <3> Advanced feed-forward function
- <4> Feedrate determination according to the acceleration for each axis
- <5> Deceleration function using the cutting load
- <6> 200-block multibuffer function

7.1.18.1**Look-ahead
acceleration/deceleration
before interpolation****Acceleration/
deceleration types**

There are the following types of acceleration/deceleration: Linear acceleration/deceleration before interpolation and bell-shaped acceleration/deceleration before interpolation.

**Look-ahead linear
acceleration/deceleration
before interpolation**

- **Example of deceleration**

Deceleration is started in a prior block so that the feedrate specified for the target block is reached at the execution.

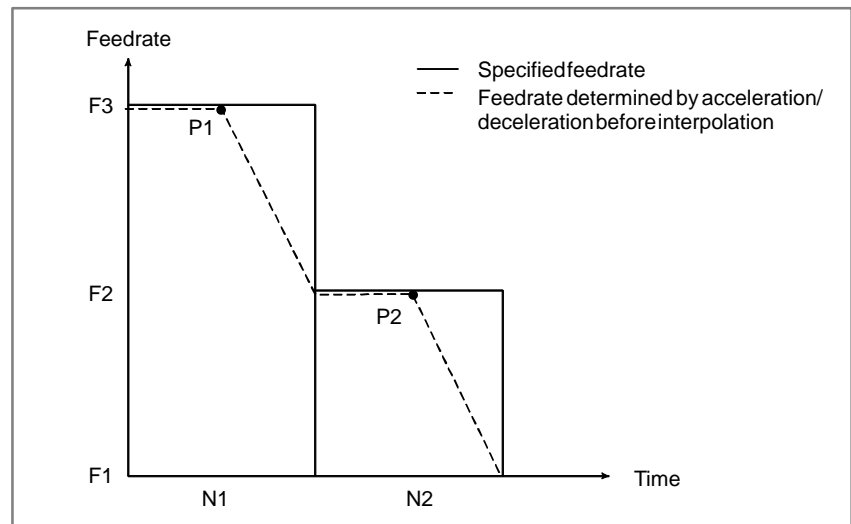

To decelerate from feedrate F3 to F2, deceleration must start with point P1.

To decelerate from feedrate F2 to F1, deceleration must start with point P2.

This function can read several tens of blocks in advance to perform deceleration extending over several tens of blocks.

● **Example of acceleration**

Acceleration is performed so that the feedrate specified for the target block is reached at the execution.

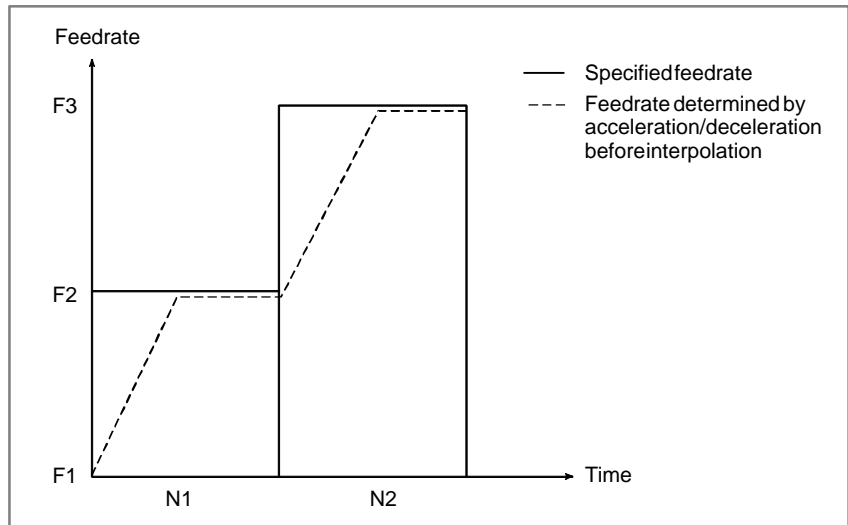

Look-ahead bell-shaped acceleration/deceleration before interpolation

● **Setting the acceleration**

Set the allowable acceleration for linear acceleration/deceleration for each axis in parameter No. 19510. Also set the acceleration change time (B) (time required for changing from the constant feedrate status (A) to the constant acceleration/deceleration status (C)) in parameter No. 8416 (parameter common to all axes). In the constant acceleration/deceleration status (C), acceleration/deceleration is performed with the maximum tangential acceleration which does not exceed the allowable acceleration for each axis set in parameter No. 19510.

The acceleration change time set in parameter No. 8416 is fixed irrespective of the tangential acceleration.

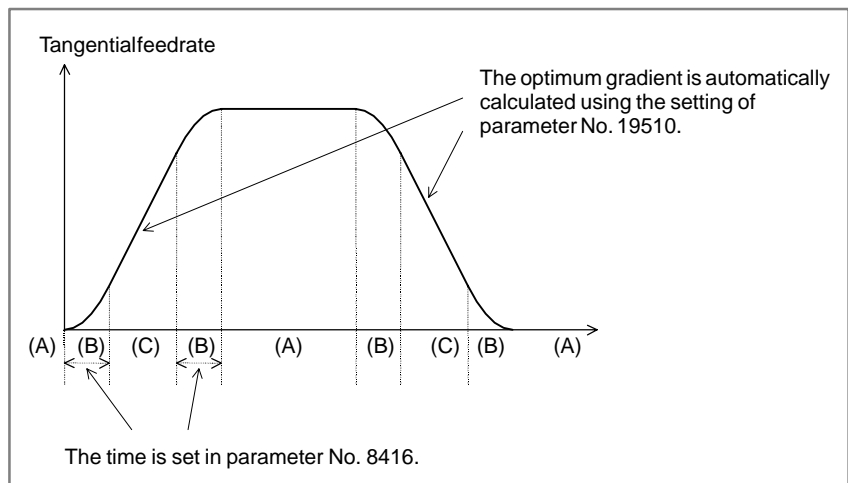

● **Determining the tangential acceleration**

Acceleration/deceleration is performed with the maximum tangential acceleration which does not exceed the acceleration set for each axis.

(Example)

- Allowable acceleration for the X-axis: 1000 mm/sec²
- Allowable acceleration for the Y-axis: 1200 mm/sec²
- Acceleration change time: 20 msec

Program:

```
N1 G01 G91 X20. F6000 Moves the tool along the X-axis.
G04 X0.01
N2 Y20. Moves the tool along the Y-axis.
G04 X0.01
N3 X20. Y20. Moves the tool along the X- and Y-axes (45 degrees).
```

The acceleration in N3 is 1414 mm/sec² and the setting (1000 mm/sec²) is used as the acceleration for the X-axis at this time.

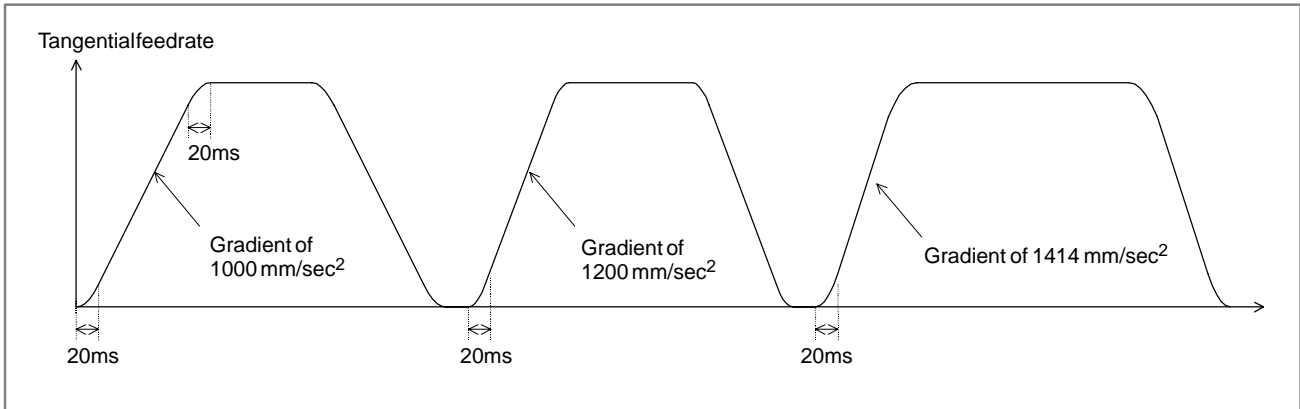

● **Acceleration**

Acceleration is started at the beginning of the block to reach the specified feedrate.

Acceleration extending over multiple blocks can be performed.

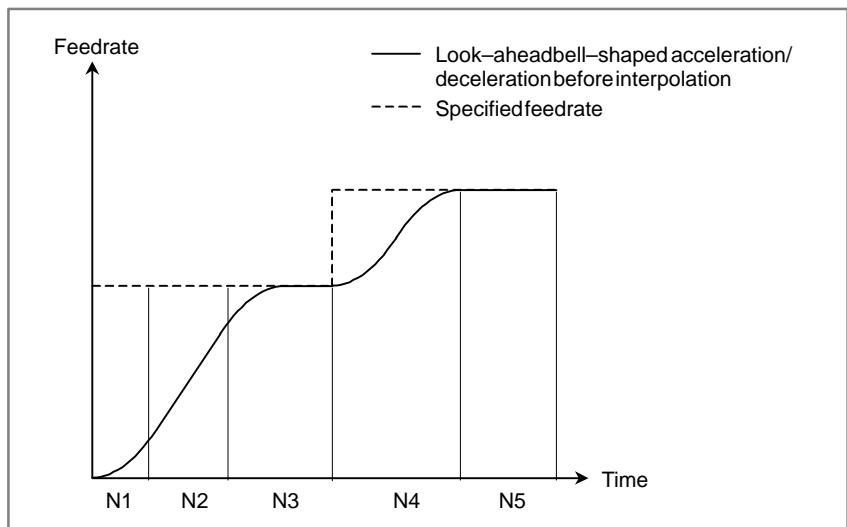

● **Deceleration**

Deceleration is started in a prior block so that the feedrate specified for the target block is reached at the beginning of the block.

Deceleration extending over multiple blocks can be performed.

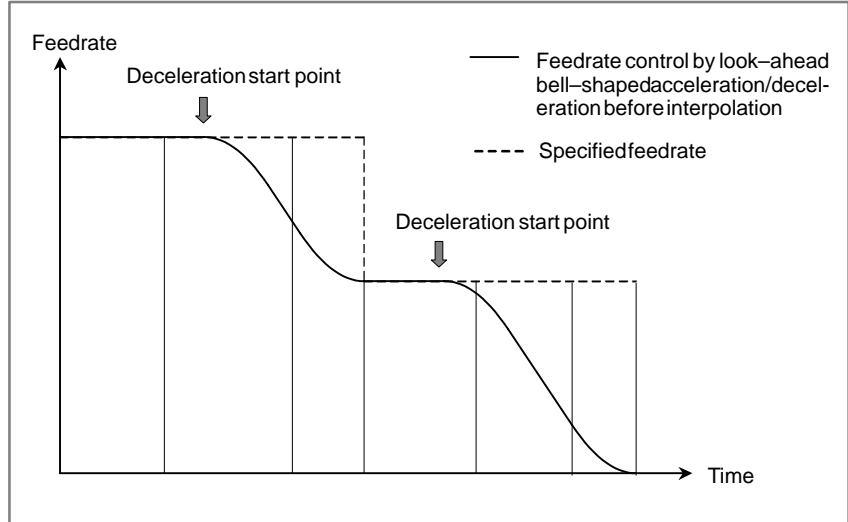

● **Deceleration according to the distance**

When the total distance of blocks read in advance reaches the distance for decelerating from the current feedrate, deceleration is started.

When look-ahead operation proceeds and the total distance of blocks increases during deceleration, acceleration is started again.

If a series of blocks with a small amount of travel are specified, the deceleration and acceleration may be alternated, which prevents the feedrate from being constant. In this case, specify a lower feedrate.

● **Single block in look-ahead bell-shaped acceleration/deceleration control before interpolation**

When a single block is specified in look-ahead bell-shaped acceleration/deceleration before interpolation, control is exercised as follows:

(1) If acceleration or deceleration is performed when a single block is specified

(a) When $A + B$ is shorter than or equal to the remaining travel distance of the block being executed when a single block is specified

Deceleration is performed and stopped so that the feedrate becomes 0 at the termination of the block being executed when a single block is specified.

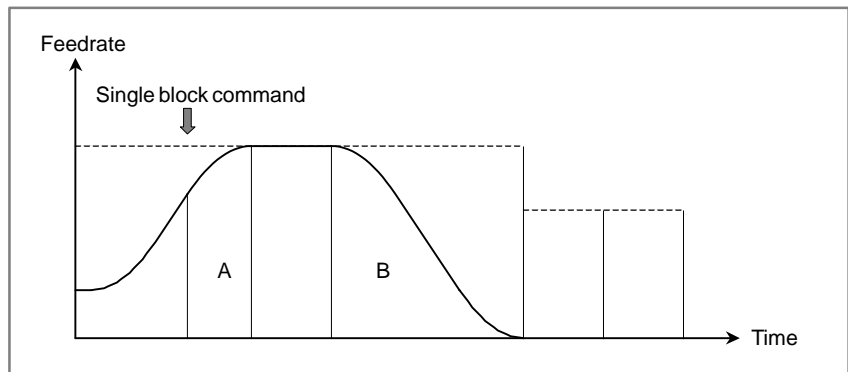

A: Travel distance required until the target feedrate is reached with the current acceleration/deceleration and acceleration/deceleration terminates

B: Travel distance required until the feedrate after acceleration/ deceleration terminates is decreased to feedrate 0

(b) When A + B is longer than the remaining travel distance of the block being executed when a single block is specified

Deceleration may extend over multiple blocks and be stopped.

Deceleration is stopped with the method described below.

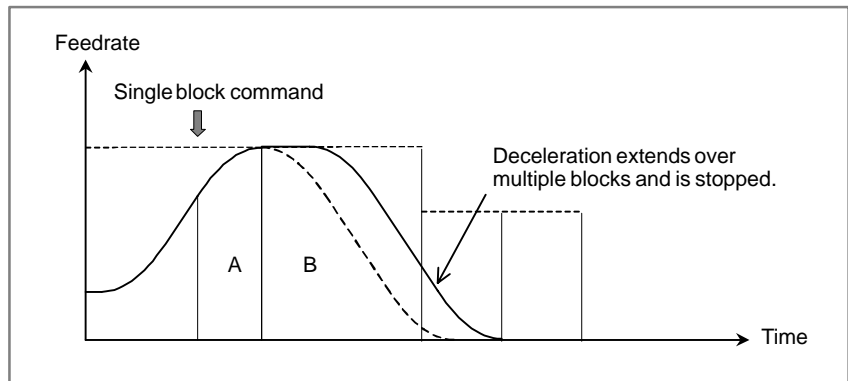

A: Travel distance required until the target feedrate is reached with the current acceleration/deceleration and acceleration/ deceleration terminates

B: Travel distance required until the feedrate after acceleration/deceleration terminates is decreased to feedrate 0

(2) If acceleration or deceleration is not performed when a single block is specified

(a) When A is shorter than or equal to the remaining travel distance of the block being executed when a single block is specified

Deceleration is performed and stopped so that the feedrate becomes 0 at the termination of the block being executed when a single block is specified.

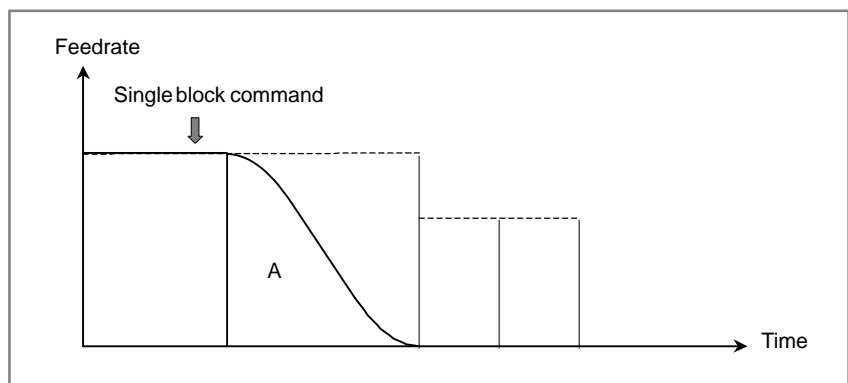

A: Travel distance required until the current feedrate is decreased to feedrate 0

- (b) When A is longer than the remaining travel distance of the block being executed when a single block is specified
Deceleration may extend over multiple blocks and be stopped.
Deceleration is stopped with the method described below.

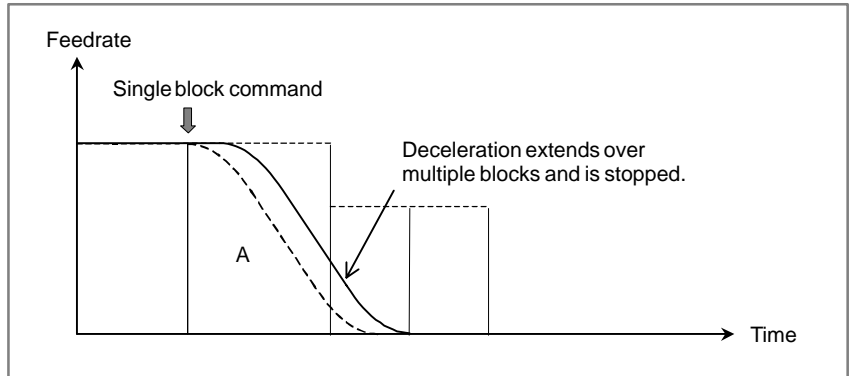

A: Travel distance required until the current feedrate is decreased to feedrate 0

- (3) How deceleration is stopped after extending over multiple blocks
Acceleration/deceleration extends over multiple blocks so that the feedrate becomes 0.

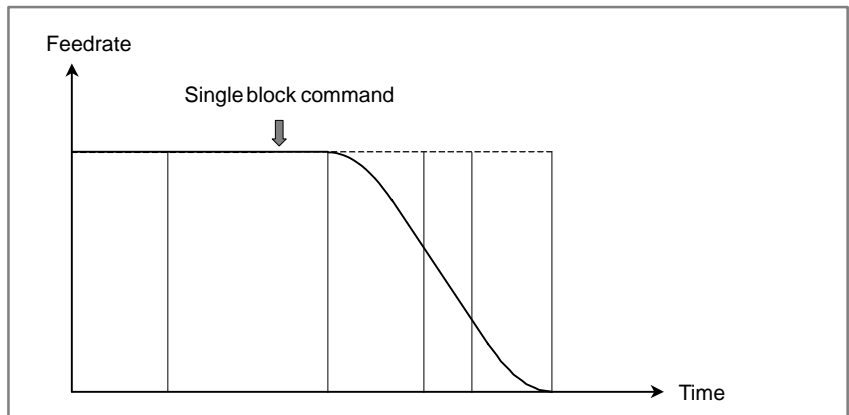

7.1.18.2 Feedrate control method

In fine HPCC mode, blocks are read in advance to automatically control the feedrate.

The feedrate is determined according to the following conditions. If the specified feedrate exceeds the determined feedrate, acceleration/deceleration before interpolation is performed so that the determined feedrate is obtained.

- <1> Change in the feedrate for each axis at each corner and allowable feedrate change amount setting
- <2> Expected acceleration for each axis and allowable feedrate setting
- <3> Change in the cutting load that is expected based on the move direction along the Z-axis

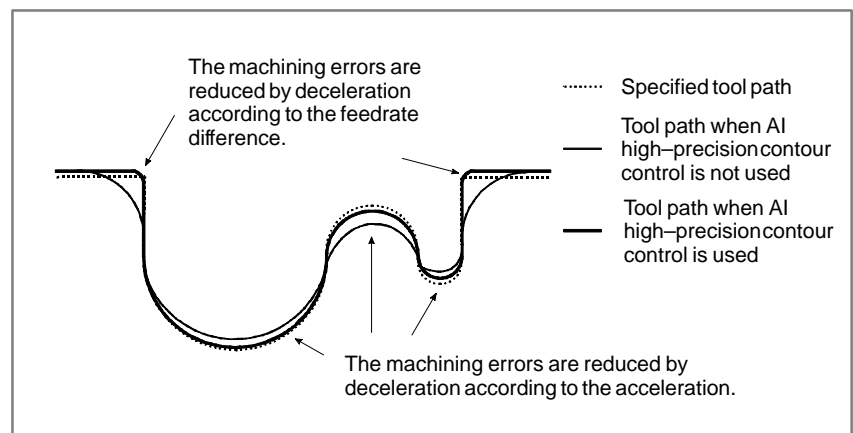

Fig. 7.1.18.2 (a)

To enable this function, set values in the following parameters:

Parameter No. 8410: Allowable feedrate difference for feedrate determination according to the feedrate difference at each corner

Parameter No. 8470: Parameter for determining the allowable feedrate for feedrate determination according to the acceleration

For details, see the description of "Parameter."

Feedrate control conditions

The feedrate is controlled in AI high-precision contour control mode as follows.

- (a) The feedrate at a corner is obtained according to the condition for the feedrate difference for each axis at each corner. Deceleration is performed so that the obtained feedrate is reached at the corner.

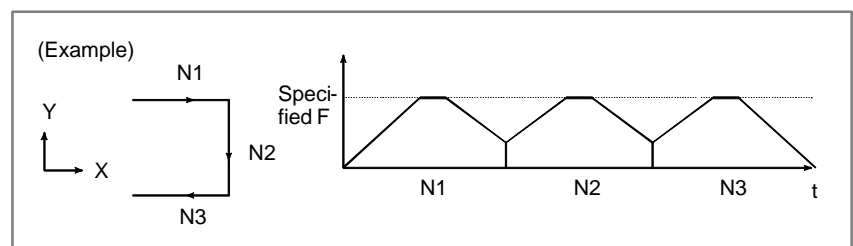

- (b) The feedrate in a block is obtained according to the condition for the acceleration for each axis at the corners at the start and end points of the block. Deceleration is performed so that the feedrate in the block does not exceed the obtained feedrate.

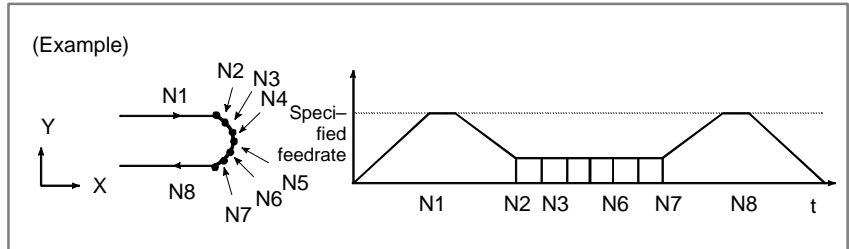

- (c) When the tool moves downward along the Z-axis, the cutting load increases. For this reason, an override is applied according to the angle at which the tool moves downward along the Z-axis.

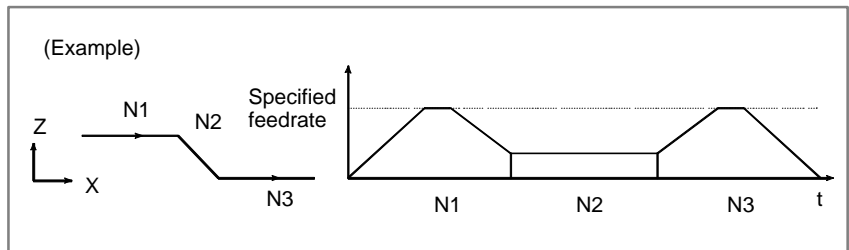

Deceleration according to the feedrate difference at each corner

With look-ahead acceleration/deceleration before interpolation, the tangential feedrate is smoothly changed. For this reason, no path error is caused by acceleration/deceleration delays, but no acceleration/deceleration is performed according to the change in the feedrate for each axis that is made at a point where the move direction changes.

The feedrate for each axis may change at a corner. In this case, using the function of decelerating according to the feedrate difference at each corner, the feedrate is determined so that the allowable feedrate difference for each axis set in parameter No. 8410 is not exceeded and deceleration is automatically performed.

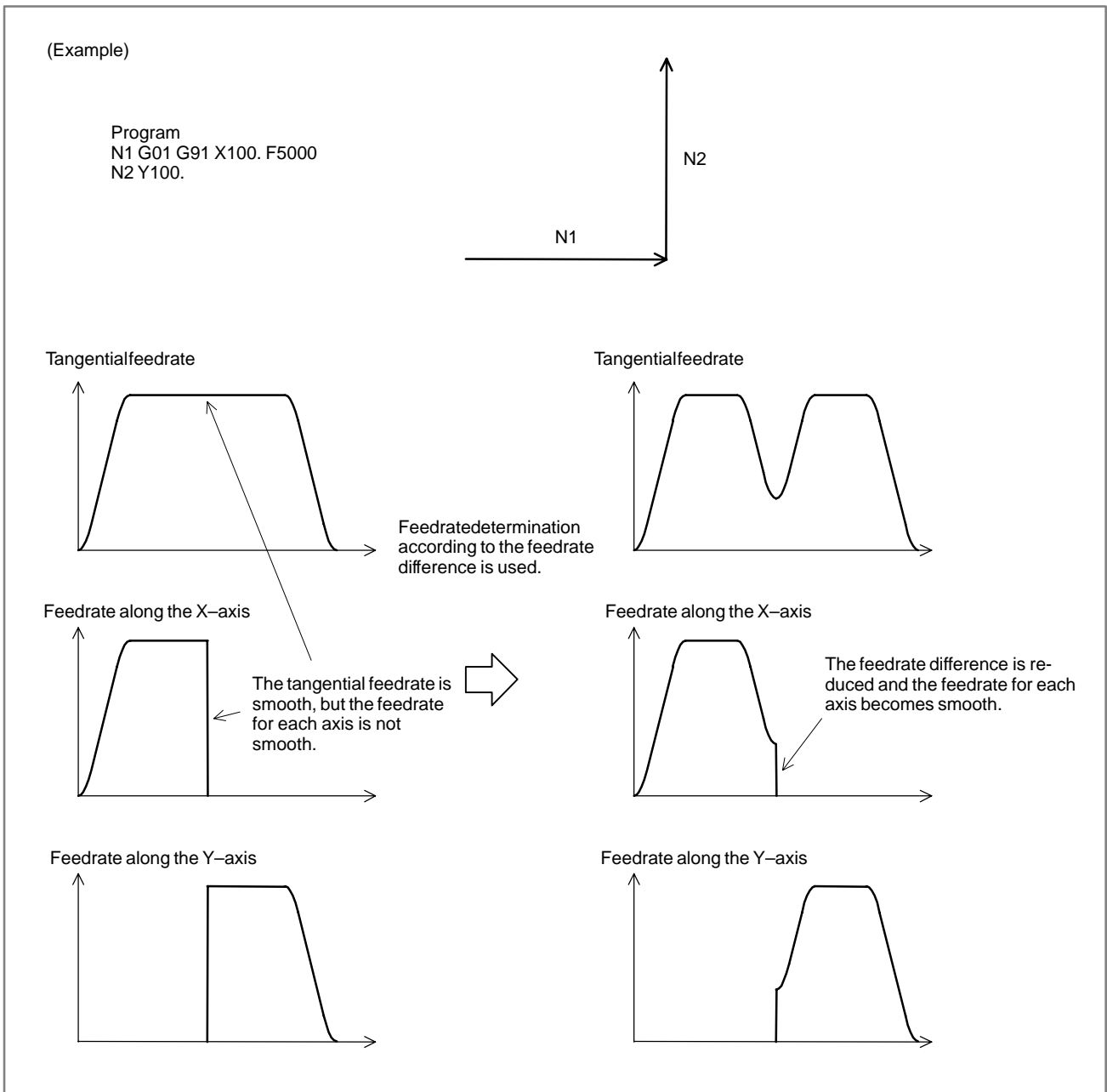

The method for deceleration according to the feedrate difference differs depending on the setting of bit 6 (FNW) of parameter No. 19500.

When this parameter is set to "0", the maximum feedrate at which the allowable feedrate difference set in parameter No. 8410 is not exceeded is used as the decreased feedrate. In this case, the decreased feedrate also differs depending on the move direction when the profile is the same as shown below.

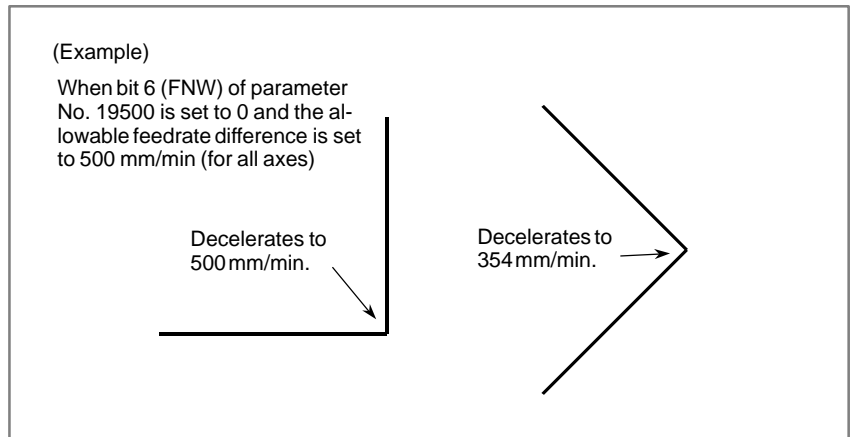

When this parameter is set to "1", the feedrate is determined according to the conditions that the allowable feedrate difference and allowable acceleration for each axis are not exceeded. When the profile is the same, the feedrate is determined according to the above conditions so that the decreased feedrate is constant irrespective of the move direction.

When this parameter is set to 1, the feedrate decreased by feedrate determination according to the feedrate difference and acceleration is reduced by up to about 30% as compared with the feedrate determined when the parameter is set to 0.

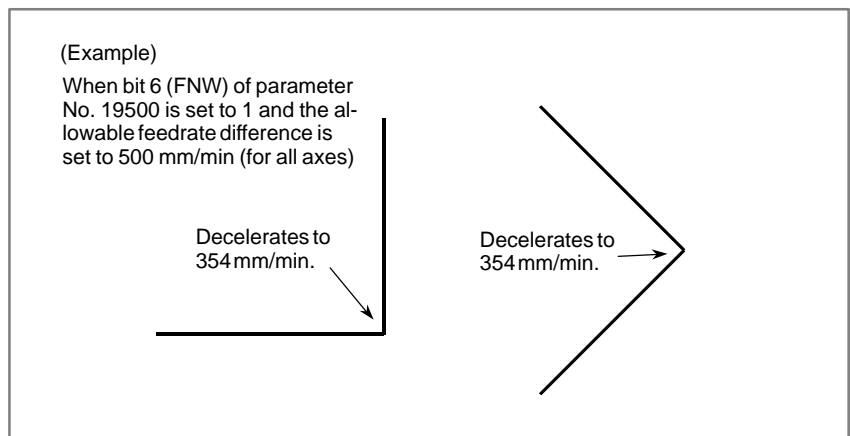

Deceleration according to the acceleration for each axis

When continuous minute straight lines form curves as shown in the example in the figure below, the feedrate difference for each axis at each corner is not so large. For this reason, deceleration according to the feedrate difference is not effective. Continuous small feedrate differences make a large acceleration for each axis as a whole.

In this case, deceleration is performed to suppress the shock on the machine and machining errors caused by too large acceleration. The feedrate is decreased so that the acceleration for each axis that is specified does not exceed the allowable acceleration set in parameter No. 8470, for all axes.

The decreased feedrate is obtained for each corner. The decreased feedrate obtained at the start or end point of the block, whichever is lower, is used as the actual feedrate.

● **Example**

In the following example, deceleration is performed because the acceleration (gradient of each dotted line in the feedrate graphs) from N2 to N4 and from N6 to N8 is too large.

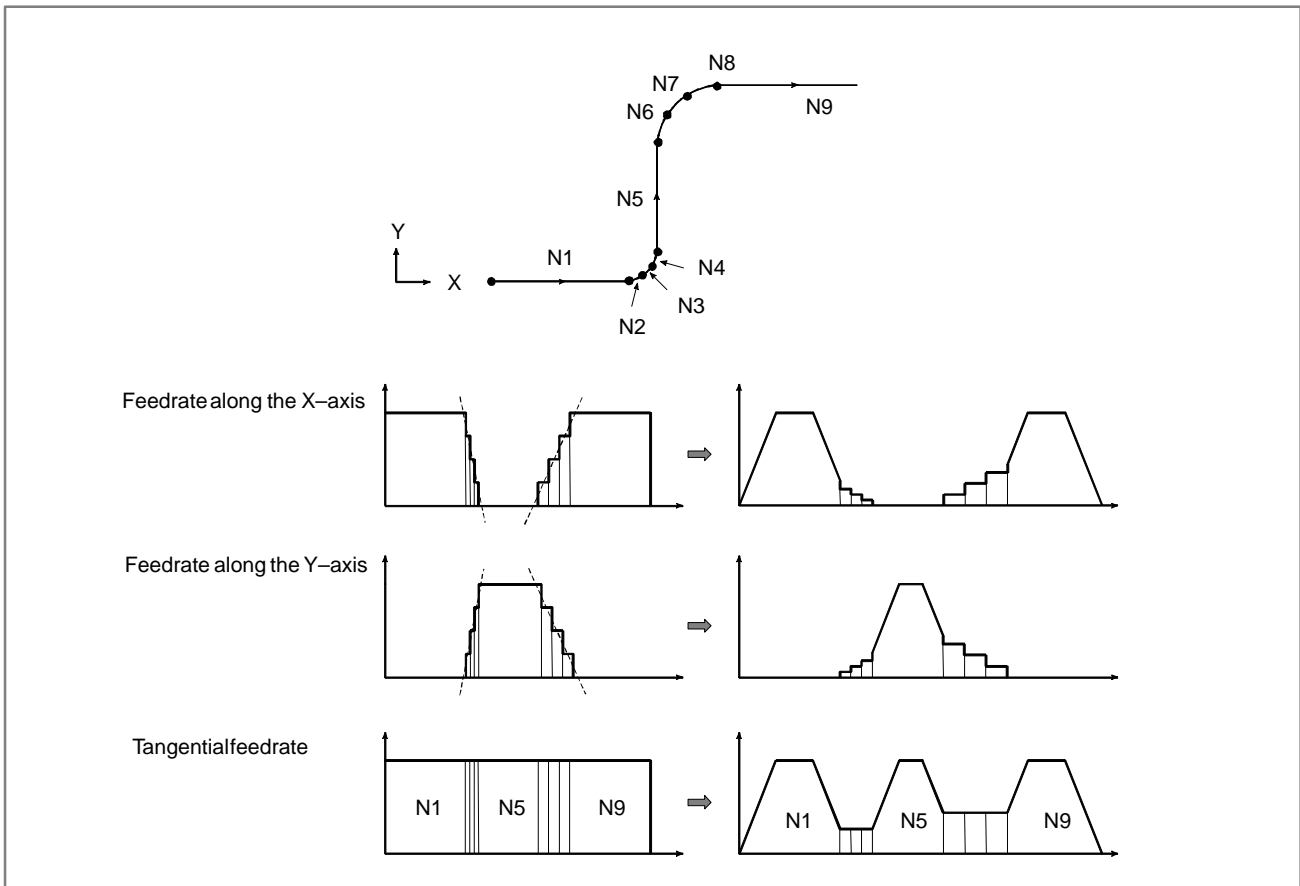
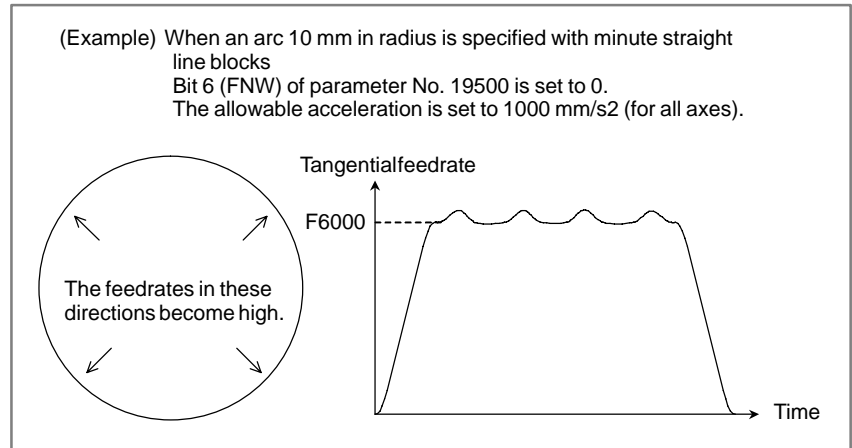

Fig. 7.1.18.2 (b) Example of deceleration according to the acceleration

The method for feedrate determination according to the acceleration differs depending on the setting of bit 6 (FNW) of parameter No. 19500. When this parameter is set to "0", the maximum feedrate at which the allowable acceleration set in parameter No. 8470 is not exceeded is used as the decreased feedrate. In this case, the decreased feedrate also differs depending on the move direction when the profile the same as shown below.



When this parameter is set to "1", the feedrate is determined according to the condition that the allowable acceleration for each axis is not exceeded. When the profile is the same, the feedrate is determined according to the above condition so that the decreased feedrate is constant irrespective of the move direction.

When this parameter is set to 1, the feedrate decreased by feedrate determination according to the feedrate difference and acceleration is reduced by up to about 30% as compared with the feedrate determined when the parameter is set to 0.

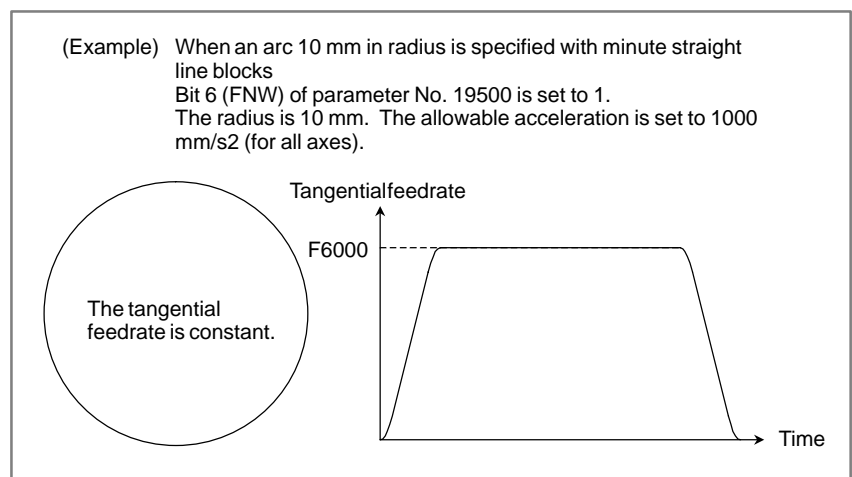

NOTE

With circular interpolation, the tangential feedrate is constant regardless of whether the parameter is set to 0 or 1.

**Deceleration according
the cutting load**

This function is valid when bit 4 (ZAG) of parameter No. 8451 is set to 1.

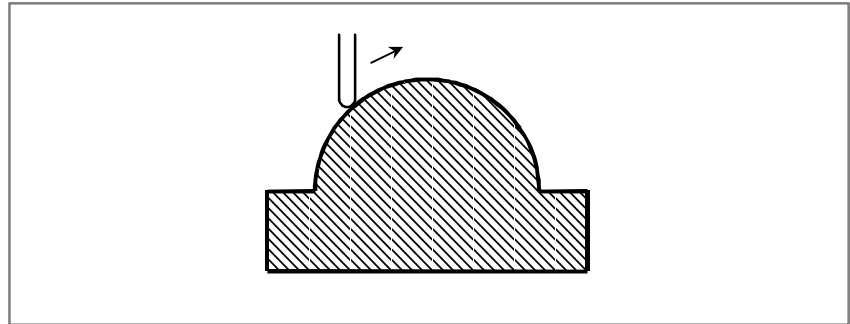

Fig. 7.1.18.2 (c) When the tool moves upward along the Z-axis

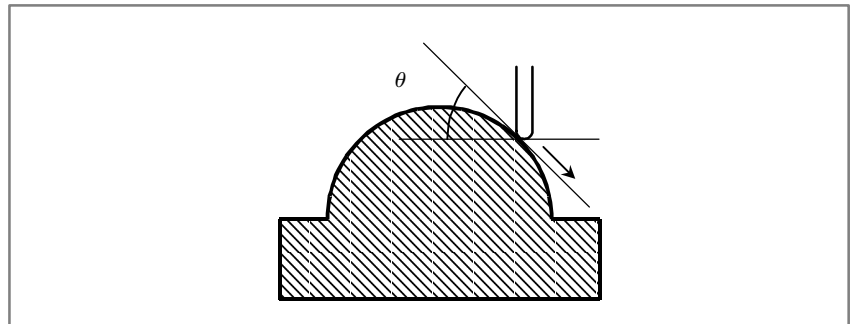

Fig. 7.1.18.2 (d) When the tool moves downward along the Z-axis

The cutting resistance during machining with the bottom of a cutter as shown in Fig. 7.1.18.2 (d) is usually higher than that during machining with the side of the cutter as shown in Fig. 7.1.18.2 (c). For this reason, deceleration is required. AI high-precision contour control uses the tool move direction along the Z-axis as a condition for calculating the machining feedrate.

Angle θ formed when the tool moves downward along the Z-axis (angle formed by the X-Y plane with the tool-center path) is shown in Fig. 7.1.18.2 (d). The angles are divided into four ranges. Set the override for each range in the corresponding parameter.

For range 2, use parameter No. 8456.

For range 3, use parameter No. 8457.

For range 4, use parameter No. 8458.

For range 1, no parameter is assigned and the override is always 100%. The feedrate obtained by other feedrate control functions is multiplied by the override for the range containing angle θ .

Range 1 $0^\circ \leq \theta < 30^\circ$

Range 2 $30^\circ \leq \theta < 45^\circ$

Range 3 $45^\circ \leq \theta < 60^\circ$

Range 4 $60^\circ \leq \theta \leq 90^\circ$

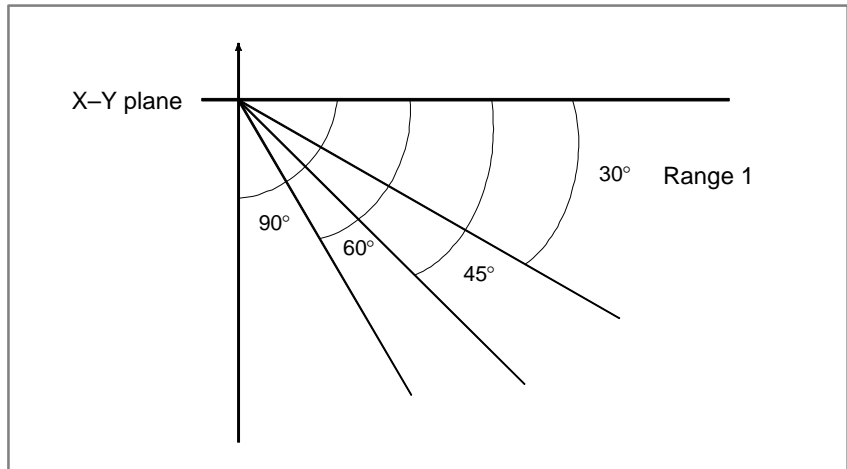

CAUTION

- 1 The function of determining the feedrate according to the cutting load is effective only when the tool is attached in the direction parallel to the Z-axis. For this reason, this function may not be able to be applied depending on the structure of the machine.
- 2 The function of determining the feedrate according to the cutting load uses NC commands to determine the move direction along the Z-axis. For this reason, if manual absolute on is used for manual intervention along the Z-axis or mirror image is applied along the Z-axis, the direction along the Z-axis cannot be determined. Therefore, when using the function of determining the feedrate according to the cutting load, do not use these functions.
- 3 After three-dimensional coordinate conversion is performed, the coordinate system after conversion is used to determine the angle at which the tool moves downward along the Z-axis.

Ignoring F code commands

Bit 7 (NOF) of parameter No. 8451 can be used to ignore all feed commands (F commands) in blocks in which AI high-precision contour control is enabled.

The feed commands include the following:

- <1> Modal F command specified prior to the block in which fine HPCC is enabled
- <2> F commands and modal F commands in blocks in which fine HPCC is enabled

If an F command is ignored, the maximum feedrate specified in parameter No. 8465 is assumed to be specified.

The specified F commands and modal F commands are stored in the CNC, however.

That is, the modal value used in the block in which enabled fine HPCC is disabled is not the modal value in the F command that is calculated by fine HPCC, but that in F command <1> or <2> described above.

**Override for the
determined feedrate**

The following shows the override specifications for the feedrate determined by the function of decelerating according to the feedrate difference in look-ahead acceleration/deceleration before interpolation or that of decelerating according to the acceleration in AI high-precision contour control.

- When bit 3 (OVR) of parameter No. 8459 is set to 0
The conventional specifications are used.
The override is disabled for the functions of decelerating according to the feedrate difference and acceleration.
- When bit 3 (OVR) of parameter No. 8459 is set to 1
The override is enabled for the functions of decelerating according to the feedrate difference and acceleration.

When bit 3 (OVR) of parameter No. 8459 is set to 1, the override is effective for the following feedrates:

- Feedrate decreased by deceleration according to the feedrate difference in look-ahead acceleration/deceleration before interpolation
- Feedrate decreased by deceleration according to the acceleration in AI high-precision contour control
- Feedrate decreased by deceleration according to the acceleration in circular interpolation
- Feedrate decreased by acceleration clamping in involute interpolation
- Lowest feedrate for deceleration according to the acceleration in AI high-precision contour control and circular interpolation
- Maximum feedrate for AI high-precision contour control

When an override is applied, the maximum cutting feedrate (parameter No. 1422, 1430, or 1432) is not also exceeded.

**Other feedrate
determination conditions**

If the specified feedrate exceeds the maximum feedrate for fine HPCC (parameter No. 8465), it is clamped to the maximum feedrate.

If the feedrate calculated by the function of decelerating according to the acceleration is lower than the lowest feedrate for the fine HPCC function of decelerating according to the acceleration that is set in parameter No. 19511, the lowest feedrate is used. If the specified feedrate is lower than the lowest feedrate, the specified feedrate is used, however.

**Acceleration/deceleration
setting and feedrate**

If look-ahead acceleration/deceleration before interpolation is specified so that the required acceleration time is at least 1 second, the specified feedrate may not be reached.

Bit 7 (FCC) of parameter No. 19500 can be set to 1 to increase the feedrate. In this case, however, the precision of curve interpolation such as circular or NURBS interpolation may be decreased.

Others

In AI high-precision contour control or AI nano high-precision contour control mode, three-dimensional coordinate conversion, coordinate system rotation, scaling, and rotary table dynamic fixture offset can be specified.

By setting the related parameter, in three-dimensional coordinate conversion, coordinate system rotation, scaling, or rotary table dynamic fixture offset mode, AI high-precision contour control or AI nano high-precision contour control mode can be turned on and off.

Parameter

1768	Time constant used for acceleration/deceleration after cutting feed interpolation in mode in which look-ahead acceleration/deceleration before interpolation is used
------	--

[Input type] Parameter input

[Data type] Word

[Unit of data] msec

[Valid data range]

Interpolation period	Valid data range
1ms	1 to 64
2ms	2 to 128

In AI high-precision contour control mode, this parameter is used, instead of the ordinary time constant (parameter No. 1622).

Always set the same time constant for all axes in this parameter, except for special applications. If different time constants are set for the axes, proper straight lines and arcs cannot be obtained.

8410	Allowable feedrate difference for feedrate determination according to the feedrate difference at each corner
------	--

[Input type] Parameter input

[Data type] Word axis

[Unit of data]

[Valid data range]

Increment system	Unit of data	Valid data range	
		IS-B	IS-C
Millimeter machine	1 mm/min	10 to 60000	1 to 6000
Inch machine	0.1 inch/min	10 to 60000	1 to 6000
Rotation axis	1 deg/min	10 to 60000	1 to 6000

When the function of determining the feedrate according to the feedrate difference at each corner is used, the change in the feedrate component for each axis may exceed the setting of this parameter at the interface of two blocks. In this case, a feedrate at which the setting is not exceeded is obtained and deceleration is performed with acceleration/deceleration before interpolation. This function reduces the shock on the machine and machining errors at each corner.

8416	Acceleration change time for bell-shaped acceleration/deceleration before interpolation
------	---

[Input type] Parameter input

[Data type] 2-word

[Unit of data] msec

[Valid data range] 0 to 200

Set the acceleration change time for bell-shaped acceleration/deceleration before interpolation (time required for changing from the constant feedrate status (A) to the constant acceleration/deceleration status (C) in which the acceleration calculated based on the acceleration set in parameter No. 19510 is used; time (B) in the following figure).

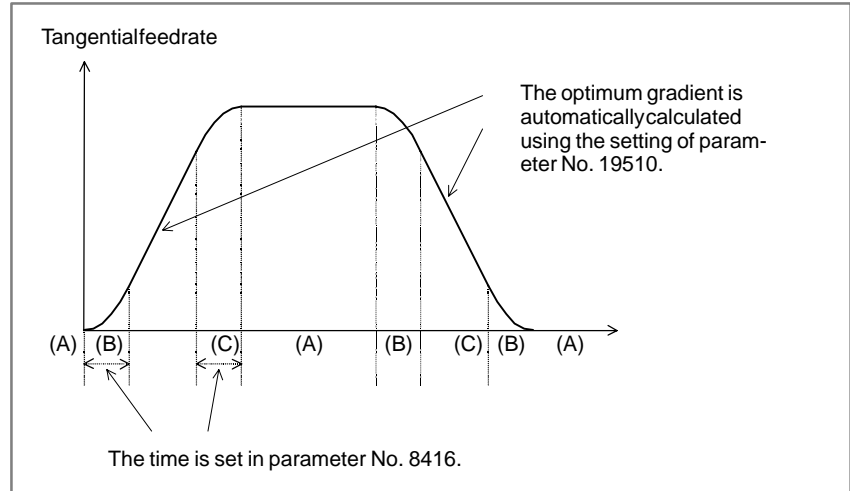

	#7	#6	#5	#4	#3	#2	#1	#0
8451	NOF			ZAG				

[Input type] Parameter input

[Data type] Bit

ZAG The function of decelerating according to the cutting load (deceleration according to the angle at which the tool moves downward along the Z-axis) in AI high-precision contour control is:

- 0 : Not performed.
- 1 : Performed.

When setting this parameter to 1, always set parameters Nos. 8456, 8457, and 8458.

NOF The F commands in AI high-precision contour control are:

- 0 : Not ignored.
- 1 : Ignored.

When this parameter is set to 1, the maximum feedrate set in parameter No. 8465 is assumed to be specified.

8456	Override for range 2 that is applied during deceleration according to the cutting load in AI high-precision contour control
8457	Override for range 3 that is applied during deceleration according to the cutting load in AI high-precision contour control
8458	Override for range 4 that is applied during deceleration according to the cutting load in AI high-precision contour control

[Input type] Parameter input

[Data type] Word

[Unit of data] %

[Valid data range] 1 to 100

For the function of decelerating according to the cutting load in AI high-precision contour control, the override set in a parameter can be applied according to the angle at which the tool moves downward along the Z-axis.

The feedrate obtained according to other conditions is multiplied by the override for the range containing angle θ at which the tool moves downward. For range 1, no parameter is assigned and the override is always 100%, however.

- Range 1 $0^\circ \leq \theta < 30^\circ$
- Range 2 $30^\circ \leq \theta < 45^\circ$
- Range 3 $45^\circ \leq \theta < 60^\circ$
- Range 4 $60^\circ \leq \theta \leq 90^\circ$

	#7	#6	#5	#4	#3	#2	#1	#0
8459					OVR			

[Input type] Parameter input

[Data type] Bit

OVR In AI high-precision contour control mode, the override for the functions of decelerating according to the feedrate difference and acceleration is:

0 : Disabled.

1 : Enabled.

This function enables the override for the following feedrates:

- Feedrate decreased by deceleration according to the feedrate difference in look-ahead acceleration/deceleration before interpolation
- Feedrate decreased by deceleration according to the acceleration in AI high-precision contour control
- Feedrate decreased by deceleration according to the acceleration in circular interpolation
- Feedrate decreased by acceleration clamping in involute interpolation
- Lowest feedrate for deceleration according to the acceleration in AI high-precision contour control and circular interpolation
- Maximum feedrate for AI high-precision contour control

When an override is applied by this function, the maximum cutting feedrate (parameter No. 1422, 1430, or 1432) is not also exceeded.

8465	Maximum feedrate for automatic feedrate control
------	---

[Input type] Parameter input

[Data type] 2-word

[Unit of data]

[Valid data range]

Increment system	Unit of data	Valid data range	
		IS-B	IS-C
Millimeter machine	1 mm/min	1 to 600000	1 to 60000
Inch machine	0.1 inch/min	1 to 600000	1 to 60000
Rotation axis	1 deg/min	1 to 600000	1 to 60000

Set the maximum feedrate for AI high-precision contour control.

If a feedrate higher than the setting of this parameter is specified in AI high-precision contour control mode, the feedrate is clamped to the feedrate set in this parameter.

If this parameter is set to 0, no clamping is performed.

When bit 7 (NOF) of parameter No. 8451 is set to 1, the tool moves, assuming that the feedrate set in this parameter is specified. If this parameter is set to 0 at this time, alarm P/S0011 occurs.

Normally, the maximum cutting feedrate (parameter No. 1422, 1430, or 1432) should be set.

8470	Parameter for determining the allowable feedrate for feedrate determination according to the acceleration
------	---

[Input type] Parameter input

[Data type] Word axis

[Unit of data] msec

[Valid data range] 0 to 32767

Set the time required for reaching the maximum cutting feedrate (parameter No. 1422, 1430, or 1432) to determine the allowable acceleration when the function of determining the feedrate according to the acceleration is used in automatic feedrate control. The larger the value set in this parameter is, the smaller the shock on the machine and machining errors become.

	#7	#6	#5	#4	#3	#2	#1	#0
19500	FCC	FNW						

[Input type] Parameter input

[Data type] Bit

FNW When the feedrate is determined according to the feedrate difference and acceleration in AI high-precision contour control:

0: Uses the maximum feedrate at which the allowable feedrate difference and acceleration for each axis are not exceeded.

1: Uses the maximum feedrate at which the allowable feedrate difference and acceleration for each axis are not exceeded. Determines the feedrate so that the decreased feedrate is constant regardless of the move direction when the profile is the same.

When this parameter is set to 1, the feedrate decreased by feedrate determination according to the feedrate difference and acceleration is reduced by up to about 30% as compared with the feedrate determined when the parameter is set to 0.

- FCC** If look-ahead acceleration/deceleration before interpolation is specified so that the acceleration time required for an axis is at least 1 second:
- 0 : Places importance on the precision. The specified feedrate may not be reached.
 - 1 : Places importance on the feedrate. The specified feedrate is reached.

NOTE

If this parameter is set to 1, the precision of curve interpolation such as circular or NURBS interpolation may be decreased.

	#7	#6	#5	#4	#3	#2	#1	#0
19503	FLP				LNS			

- LNS** The linear interpolation blocks with small movement in AI high precision contour control mode or AI NANO high precision contour control mode will be
- 0 : Interpolated as smooth curve.
 - 1 : Interpolated as linear segments.
- Set 1 to this parameter. (Refer to following Note.)

- FLP** The linear interpolation blocks with small movement in AI high precision contour control mode or AI NANO high precision contour control mode will be
- 0 : Interpolated as linear segments.
 - 1 : Interpolated as smooth curve.
- Set 0 to this parameter. (Refer to following Note.)

NOTE

In AI high precision contour control mode or AI NANO high precision contour control mode, when very small linear interpolation blocks which have the following 1) condition, are commanded continuously, since these commands are assumed as die mold program, these blocks may be interpolated as smooth curve which is generated internally.

$$\text{Block length (mm)} \leq \frac{\text{Commanded Feedrate (mm/min)}}{7500} \quad (1)$$

For example, in case the commanded feedrate is 6000mm/min, the block whose length is less than 0.8mm satisfies the above formula (1).

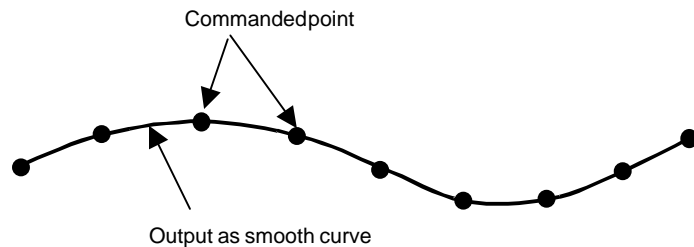

These parameters can change whether the linear interpolation blocks with small movement are interpolated as linear segments or smooth curve. These parameters are available on the following software series and edition.

On the software which has the parameter No.19503#7 (FLP), the parameter No.19503#3 (LNS) is not effective.

Currently, because the commanded feedrate is faster, the block length of the previous 1) condition becomes longer. In this condition, if CNC interpolates as a smooth curve, the deviation between commanded path and interpolated path becomes bigger.

Therefore, in general, the linear interpolation blocks with small movement should be interpolated as linear segments, not as a smooth curve. From the above point of view, these parameters should be set as follows.

(1) Parameter No.19503#3 (LNS)

This parameter is available in case both CNC software and RISC software are the following series and edition.

In this condition, this parameter No.19503#3 (LNS) should be set to "1".

CNC software

FS16i-MB: B0H1/17 ~, or B0HA/01 ~

FS18i-MB: BDH1/17 ~, or BDHA/01 ~

FS18i-MB5: BDH5/07 ~

RISC software

B451/14 ~, or B45A/01 ~ 05

NOTE

(2) Parameter No.19503#7 (FLP)

This parameter is available in case both CNC software and RISC software are the following series and edition.

In this condition, this parameter No.19503#7 (FLP) should be set to "0". Also, in this condition, the parameter No.19503#3 (LNS) is not effective.

CNC software

FS16*i*-MB: B0H1/17 ~, or B0HA/01 ~

FS18*i*-MB: BDH1/17 ~, or BDHA/01 ~

FS18*i*-MB5: BDH5/07 ~

RISC software

B45A/06 ~

19510

Time constant for acceleration/deceleration before interpolation for each axis

[Input type] Parameter input

[Data type] Word axis

[Unit of data] msec

[Valid data range] 0 to 32767

When this parameter is set to 0 for all axes, look-ahead acceleration/deceleration before interpolation is not performed.

If the allowable acceleration setting for an axis is more than double the setting for another axis, the feedrate may be temporarily decreased at a corner at which the move direction sharply changes.

19511

Lowest feedrate for the function of decelerating according to the acceleration in AI high-precision contour control

[Input type] Parameter input

[Data type] 2-word

[Unit of data] mm/min, inch/min, deg/min (machine unit)

Increment system	Unit of data	Valid data range	
		IS-B	IS-C
Millimeter machine	1 mm/min	1 to 240000	1 to 24000
Inch machine	0.1 inch/min	1 to 240000	1 to 24000
Rotation axis	1 deg/min	1 to 240000	1 to 24000

The function of decelerating according to the acceleration in AI high-precision contour control automatically calculates the optimum feedrate according to the profile.

The calculated feedrate may be very low depending on the profile, however. In this case, to prevent the feedrate from becoming too low, deceleration is performed so that the feedrate is not below that set in this parameter.

If the override is enabled for the function of decelerating according to the cutting load, the feedrate may be lower than the lowest feedrate.

When AI high-precision contour control is not used, the lowest feedrate for deceleration according to the acceleration in circular interpolation is specified in parameter No. 19512.

NOTE

In involute interpolation, the lowest feedrate set for "acceleration clamping near the basic circle" in automatic feedrate control in involute interpolation is used.

Note**NOTE**

- 1 If the allowable acceleration setting for an axis is more than double the setting for another axis, the feedrate may be temporarily decreased at a corner at which the move direction sharply changes.
- 2 If the machine lock signal is turned on during movement in mode in which look-ahead acceleration/deceleration before interpolation is used, the machine enters the machine lock status after termination of deceleration.
- 3 If a non-movement block or one-shot G code command such as G09 is found in mode in which look-ahead acceleration/deceleration before interpolation is used, the movement is decelerated and temporarily stopped in the preceding block.
- 4 When the dry run signal is inverted from "0" to "1" or from "1" to "0" during movement along an axis, acceleration/deceleration is performed to the specified feedrate without deceleration to feedrate 0. The function of decelerating according to the feedrate difference at each corner is also valid during dry run.

**7.1.19
RISC Processor
Operation
(AI High-precision
Contour Control/
AI Nano High-
precision Contour
Control/Tool Length
Compensation Along
the Tool Axis/
Three-dimensional
Cutter Compensation/
Tool tip Control/
Three-dimensional
Circular Interpolation)
(M Series)**

General

For the following functions, high-speed operations are executed on the RISC processor:

- AI high-precision contour control
- AI nano high-precision contour control
- Tool tip control
- Tool length compensation along the tool axis
- Three-dimensional cutter compensation
- Three-dimensional circular interpolation

**RISC command
extension**

Bits 0 to 5 of parameter No. 19600 can be set to extend the following functions so that they are executed on the RISC processor.

5-axis control mode		Function name
On	Off	
G51	G50	Scaling
G51.1	G50.1	Programmable mirror image
G54.2	G54.2 P0	Rotary table dynamic fixture offset
G68	G69	Coordinate system rotation
G68 I_J_K_	G69	Three-dimensional coordinate conversion
G41, G42	G40	Cutter compensation C

When execution of the above commands on the RISC processor is specified, AI high-precision contour control, AI nano high-precision contour control, tool tip control, tool length compensation along the tool axis, three-dimensional cutter compensation, and three-dimensional circular interpolation can be specified in the above function modes.

For restrictions on the above functions, see the description of "Restrictions."

When execution of the above commands on the CNC is specified, AI high-precision contour control, AI nano high-precision contour control, tool tip control, tool length compensation along the tool axis, three-dimensional cutter compensation, and three-dimensional circular interpolation can be specified only when the above functions are canceled.

If the above functions are not canceled and AI high-precision contour control, AI nano high-precision contour control, tool tip control, tool length compensation along the tool axis, three-dimensional cutter compensation, or three-dimensional circular interpolation is specified, alarm P/S5012 occurs.

5-axis control mode

The status in which tool tip control, tool length compensation along the tool axis, three-dimensional cutter compensation, or three-dimensional circular interpolation is executed is generically called 5-axis control mode. This mode includes the status in which a function set by RISC command extension is executed.

Specifications

Function	Specifics	Remarks
Axis control		
Number of controlled axes	3	
Number of controlled paths	1	
Number of simultaneously controlled axes	2	
Extended number of controlled axes	Up to 8	
Extended number of simultaneously controlled axes	Up to 6	
Axis control by the PMC		An axis specified in AI high-precision contour control, AI nano high-precision contour control, or 5-axis control mode cannot be specified as a PMC axis in AI high-precision contour control, AI nano high-precision contour control, or 5-axis control mode.
Cs contour control function		If a Cs axis is specified in AI high-precision contour control or AI nano high-precision contour control mode, nano-interpolation and advanced feed forward are temporarily canceled.
Axis names	For basic three axes, any of X, Y, and Z. For additional axes, any of A, B, C, U, V, and W.	
Twin-table control		Switching among synchronous, independent, and normal operation cannot be performed in AI high-precision contour control or AI nano high-precision contour control mode.
Simple synchronous control		Switching between synchronous and normal operation cannot be performed in AI high-precision contour control or AI nano high-precision contour control mode.

Function	Specifics	Remarks
Least input increment	0.001 mm, 0.001 deg, 0.0001 inch	
One-tenth input increment	0.0001 mm, 0.0001 deg, 0.00001 inch	
Inch/metric conversion		Switching between inch and metric modes cannot be performed in AI high-precision contour control, AI nano high-precision contour control, or 5-axis control mode.
Interlock	All axes, each axis	
Machine lock	All axes, each axis	
Emergency stop		
Stored stroke check 1		The setting with the external stroke limit setting signal cannot be made in AI high-precision contour control, AI nano high-precision contour control, or 5-axis control mode. The OT limit cannot be overrun in AI high-precision contour control or AI nano high-precision contour control mode.
Stored stroke check 2		If G22 or G23 is specified in AI high-precision contour control or AI nano high-precision contour control mode, the mode is temporarily canceled and buffering is suppressed. G22 or G23 specified in 5-axis control mode causes an alarm.
Mirror image		The signal status cannot be changed in AI high-precision contour control, AI nano high-precision contour control, or 5-axis control mode.
Separate backlash compensation for cutting feed/rapid traverse		

Operation

Automatic operation		
MDI operation		If MDI intervention is performed in AI high-precision contour control or AI nano high-precision contour control mode, the mode is temporarily canceled automatically and buffering is suppressed. At this time, G05P10000 or G05P0 cannot be specified by MDI. MDI intervention specified in 5-axis control mode causes a warning.
Cycle start/feed hold		
Program stop/program end		
Reset		
Program restart		
Dry run		
Single block		

Function	Specifics	Remarks
Interpolation functions		
Positioning	G00	The advanced preview control function, multibuffer function, AI high-precision contour control function excluding nano-interpolation, and AI nano high-precision contour control function are disabled.
Cutting mode	G64	
Linear interpolation	G01	
Circular interpolation	G02, G03	
Helical interpolation	Circular interpolation + linear interpolation for up to two axes	
Helical interpolation B	Circular interpolation + linear interpolation for up to four axes	
Involute interpolation	G02.3, G03.2	
Three-dimensional circular interpolation	G02.4, G03.4	If three-dimensional circular interpolation is specified in mode other than AI high-precision contour control or AI nano high-precision contour control mode, deceleration starts at the end point in the block immediately preceding the interpolation or in the block in which the interpolation is canceled. After that, an in-position check is performed.
Smooth interpolation	G05.1	Smooth interpolation can be specified in AI high-precision contour control or AI nano high-precision contour control mode. Smooth interpolation specified in 5-axis control mode causes an alarm.
NURBS interpolation	G06.2	NURBS interpolation can be specified in AI high-precision contour control or AI nano high-precision contour control mode. NURBS interpolation specified in 5-axis control mode causes an alarm.

Feed functions

Feed per minute	G94	
Cutting feedrate clamp		
Linear acceleration/deceleration after cutting feed interpolation		
Bell-shaped acceleration/deceleration after cutting feed interpolation		
Feedrate override	0 to 254% (in increments of 1%)	
Second feedrate override	0 to 254% (in increments of 1%)	
One-digit F code feed		The feedrate cannot be changed using a manual handle.
Inverse time feed	G93	

Function	Specifics	Remarks
Look-ahead linear acceleration/deceleration before interpolation		
Look-ahead bell-shaped acceleration/deceleration before interpolation	Constant acceleration change time type	
AI high-precision contour control	AI nano high-precision contour control	

Program input

Program code	Automatic EIA/ISO determination	
Program format	Word address format	
Control in/out		
Optional block skip		
Absolute/incremental programming	G90/G91	
10-fold input unit		
Plane selection	G17, G18, G19	
Rotary axis roll over		
Workpiece coordinate system	G54 to G59	AI high-precision contour control or AI nano high-precision contour control mode is temporarily canceled automatically and buffering is suppressed. A workpiece coordinate system specified in 5-axis control mode causes an alarm.
Addition of workpiece coordinate system pairs	48 pairs, 300 pairs	AI high-precision contour control or AI nano high-precision contour control mode is temporarily canceled automatically and buffering is suppressed. Addition of a workpiece coordinate system pair in 5-axis control mode causes an alarm.
Manual absolute on/off		
Programmable data input	G10	AI high-precision contour control or AI nano high-precision contour control mode is temporarily canceled automatically and buffering is suppressed.
Calling a subprogram stored in external memory	M198	
Subprogram call	M98	
Arc radius R programming		
Scaling	G50, G51	By setting the related parameter, AI high-precision contour control or AI nano high-precision contour control mode can be turned on and off in scaling mode (G51). If the parameter is not set, turning AI high-precision contour control or AI nano high-precision contour control mode on or off in scaling mode (G51) causes an alarm. Scaling mirror image with a negative magnification cannot be performed.

Function	Specifics	Remarks
Coordinate system rotation	G68, G69	By setting the related parameter, AI high-precision contour control or AI nano high-precision contour control mode can be turned on and off in coordinate system rotation mode (G68). If the parameter is not set, turning AI high-precision contour control or AI nano high-precision contour control mode on or off in coordinate system rotation mode (G68) causes an alarm.
Three-dimensional coordinate conversion	G68, G69	By setting the related parameter, AI high-precision contour control or AI nano high-precision contour control mode can be turned on and off in three-dimensional coordinate conversion mode (G68). If the parameter is not set, turning AI high-precision contour control or AI nano high-precision contour control mode on or off in three-dimensional-coordinate conversion mode (G68) causes an alarm.

Auxiliary functions/spindle-speed functions

Auxiliary functions		AI high-precision contour control or AI nano high-precision contour control mode is temporarily canceled automatically and buffering is suppressed. In 5-axis control mode, only a miscellaneous function without a move command is available.
Second auxiliary functions		AI high-precision contour control or AI nano high-precision contour control mode is temporarily canceled automatically and buffering is suppressed. In 5-axis control mode, only a second auxiliary function without a move command is available.
Multiple M commands in a single block		Up to three M commands can be specified. AI high-precision contour control or AI nano high-precision contour control mode is temporarily canceled automatically and buffering is suppressed. In 5-axis control mode, only multiple M commands without a move command are available.
Spindle-speed functions		AI high-precision contour control or AI nano high-precision contour control mode is temporarily canceled automatically and buffering is suppressed. In 5-axis control mode, only a spindle-speed function without a move command is available.

Tool functions

Tool functions (8-digit T code)		AI high-precision contour control or AI nano high-precision contour control mode is temporarily canceled automatically and buffering is suppressed. In 5-axis control mode, only a tool function without a move command is available.
Tool length compensation	G43	
Cutter compensation C	G38, G39, G40, G41, G42	If a command which automatically cancels AI high-precision contour control or AI nano high-precision contour control mode temporarily is specified, buffering is suppressed. For this reason, the vector is held.
Three-dimensional cutter compensation	G41.2, G42.2, G41.3	A command which automatically cancels AI high-precision contour control or AI nano high-precision contour control mode temporarily cannot be specified. An independent M, S, T, or B command without a move command can be specified, however.
Tool length compensation along the tool axis	G43.1	A command which automatically cancels AI high-precision contour control or AI nano high-precision contour control mode temporarily cannot be specified. An independent M, S, T, or B command without a move command can be specified, however.

Function	Specifics	Remarks
Tool tip control	G43.4, G43.5	A command which automatically cancels AI high-precision contour control or AI nano high-precision contour control mode temporarily cannot be specified. An independent M, S, T, or B command without a move command can be specified, however.
Rotary table dynamic fixture offset	G54.2	By setting the related parameter, AI high-precision contour control or AI nano high-precision contour control mode can be turned on and off in rotary table dynamic fixture offset mode (G54.2P_). If the parameter is not set, turning AI high-precision contour control or AI nano high-precision contour control mode on or off in rotary table dynamic fixture offset mode (G54.2P_) causes an alarm.

Signal

HPCC mode signal MHPCC <F066#6>

[Classification] Output signal

[Function] This signal reports that the following functions are executed on the RISC processor:

- AI high-precision contour control
- AI nano high-precision contour control
- Tool tip control
- Tool length compensation along the tool axis
- Three-dimensional cutter compensation
- Three-dimensional circular interpolation

When bit 0 to 5 of parameter No. 19600 is set to enable AI high-precision contour control or AI nano high-precision contour control in the mode of the corresponding function listed below, this signal also reports that the function is executed on the RISC processor:

- Three-dimensional coordinate conversion
- Programmable mirror image
- Scaling
- Coordinate system conversion
- Rotary table dynamic fixture offset
- Cutter compensation C

[Output condition] The MHPCC signal is turned to "1" when:

- G05 P10000 is specified in the program. (AI high-precision contour control or AI nano high-precision contour control)
- G43.4 or G43.5 is specified in the program. (Tool tip control)
- G43.1 is specified in the program. (Tool length compensation along the tool axis)
- G41.2, G41.3, or G42.2 is specified in the program. (Three-dimensional cutter compensation)
- G02.4 or G03.4 is specified in the program. (Three-dimensional circular interpolation)

- When bit 0 (R_SCL) of parameter No. 19600 is set to 1, G51 is specified in the program. (Scaling)
- When bit 1 (R_MIR) of parameter No. 19600 is set to 1, G51.1 is specified in the program. (Programmable mirror image)
- When bit 2 (R_FXO) of parameter No. 19600 is set to 1, G54.2Pn (n = 1 to 8) is specified in the program. (Rotary table dynamic fixture offset)
- When bit 3 (R_ROT) of parameter No. 19600 is set to 1, G68 is specified in the program. (Coordinate system rotation)
- When bit 4 (R_3DC) of parameter No. 19600 is set to 1, G68 is specified in the program. (Three-dimensional coordinate conversion)
- When bit 5 (R_CRC) of parameter No. 19600 is set to 1, G41 or G42 is specified in the program. (Cutter compensation C)

The MHPCC signal is turned to "0" when the following modes are all canceled by the program or reset:

- G05 P0 is specified in the program. (AI high-precision contour control or AI nano high-precision contour control)
- G49 is specified in the program. (Tool tip control and tool length compensation along the tool axis)
- G40 is specified in the program. (Three-dimensional cutter compensation)
- A modal G code in group 01 other than G02.4 or G03.4 is specified in the program. (Three-dimensional circular interpolation)
- When bit 0 (R_SCL) of parameter No. 19600 is set to 1, G50 is specified in the program. (Scaling)
- When bit 1 (R_MIR) of parameter No. 19600 is set to 1, G50.1 is specified in the program. (Programmable mirror image)
- When bit 2 (R_FXO) of parameter No. 19600 is set to 1, G54.2P0 is specified in the program. (Rotary table dynamic fixture offset)
- When bit 3 (R_ROT) of parameter No. 19600 is set to 1, G69 is specified in the program. (Coordinate system rotation)
- When bit 4 (R_3DC) of parameter No. 19600 is set to 1, G69 is specified in the program. (Three-dimensional coordinate conversion)
- When bit 5 (R_CRC) of parameter No. 19600 is set to 1, G40 is specified in the program. (Cutter compensation C)

Parameter

7510

Maximum number of axes controlled on the RISC processor

[Input type] Parameter input

[Data type] Byte

[Valid data range] 1, 2, 3, ..., the number of controlled axes

Set the maximum number of axes to be controlled on the RISC processor.

Example) Assume that the first and subsequent axes are the X-, Y-, Z-, A-, B-, and C-axes. To enable control on the RISC processor for the first to fourth axes (A), the setting is 4. At this time, control on the RISC processor is also enabled for the X-, Y-, and Z-axes.

X-, Y-, Z-, and A-axes Axes for which control on the RISC processor is enabled

B- and C-axes Axes for which control on the RISC processor is disabled

	#7	#6	#5	#4	#3	#2	#1	#0
8480		R12	R11	R10				

[Input type] Parameter input

[Data type] Bit

Set the interpolation period on the RISC processor. Always set either of the following values.

Interpolation period	R12	R11	R10
1ms	0	1	1
2ms	0	0	1

	#7	#6	#5	#4	#3	#2	#1	#0
8485							G81	

[Input type] Parameter input

[Data type] Bit

G81 In AI high-precision contour control or AI nano high-precision contour control mode, the canned cycle for hole machining is:

0 : Disabled. (Alarm P/S5000 occurs.)

1 : Enabled.

	#7	#6	#5	#4	#3	#2	#1	#0
19600			R_CRC	R_3DC	R_ROT	R_FXO	R_MIR	R_SCL

[Input type] Parameter input

[Data type] Bit

R_SCL The scaling function is:

0 : Executed on the CNC.

1 : Assumed to be 5-axis control mode and executed on the RISC processor.

R_MIR The programmable mirror image function is:

0 : Executed on the CNC.

1 : Assumed to be 5-axis control mode and executed on the RISC processor.

R_FXO The rotary table dynamic fixture offset function is:

0 : Executed on the CNC.

1 : Assumed to be 5-axis control mode and executed on the RISC processor.

- R_ROT** The coordinate system rotation function is:
 0 : Executed on the CNC.
 1 : Assumed to be 5-axis control mode and executed on the RISC processor.
- R_3DC** The three-dimensional coordinate conversion function is:
 0 : Executed on the CNC.
 1 : Assumed to be 5-axis control mode and executed on the RISC processor.
- R_CRC** The cutter compensation C function is:
 0 : Executed on the CNC.
 1 : Assumed to be 5-axis control mode and executed on the RISC processor.

Restrictions

For the functions which can be specified and the restrictions in AI high-precision contour control, AI nano high-precision contour control, or 5-axis control mode, see the description of "Available functions" and "Restrictions."

Restriction 1

In AI high-precision contour control, AI nano high-precision contour control, or 5-axis control mode, the following functions are available, but the status of these functions cannot be changed:

- Inch input/metric input (Changing the status using G20 or G21 causes alarm P/S5000.)
- Mirror image (The signal status cannot be changed.)
- One-digit F code feed (The feedrate cannot be changed with a manual handle.)

Restriction 2

If one of the following functions is specified in AI high-precision contour control or AI nano high-precision contour control mode, the mode is temporarily canceled automatically and buffering is suppressed:

- MDI operation
- Workpiece coordinate system (G54 to G59)
- Programmable data input (G10)
- Miscellaneous function
- Second auxiliary function
- Multiple M commands in a single block
- Spindle-speed function
- Tool function

Restriction 3

The following functions cannot be specified in AI high-precision contour control, AI nano high-precision contour control, or 5-axis control mode. If one of the functions is specified, an alarm occurs.

- Custom macro B
- Exponential interpolation G02.3, G03.3
- Dwell G04
- Functions related to high-speed machining
 G05 (other than G05P10000 and
 G05P0)

- AI contour control G05.1Q1, G5.1Q0
- Hypothetical axis interpolation G07
- Advanced preview control G08 (Use AI high-precision contour control.)
- Polar coordinate interpolation G12.1, G13.1
- Polar coordinate command G15, G16
- Reference position return check G27
- Reference position return G28
- Second reference position return G30
- Third and fourth reference position return G30
- Skip G31
- Threading G33
- Automatic tool length measurement G37
- Functions related to normal direction control G40.1, G41.1, G42.1
- Cutter compensation B G41, G42, G39 (Cutter compensation C can be specified.)
- Three-dimensional tool compensation G41
- Grinding-wheel wear compensation G41
- Specified direction tool length compensation G41
- Tool offset G45, G46, G47, G48
- Programmable mirror image G50.1, G51.1
- Local coordinate system G52
- Machine coordinate system selection G53
- Single direction positioning G60
- Automatic corner override G62
- Tapping mode G63
- Functions related to macro call G65, G66, G67 (Subprogram call can be specified.)
- Figure copy G72.1, G72.2
- Electric gear box G80, G81
- Hobbing machine function G80, G81
- External motion function G81
- Chopping G81.1
- Small hole peck drilling cycle G83
- Changing workpiece coordinate system G92
- Workpiece coordinate system preset G92.1

- Feed per revolution G95
- Constant surface speed control G96, G97
- In-feed control G160, G161

Restriction 4

In AI high-precision contour control, AI nano high-precision contour control, and 5-axis control modes, the following functions are unavailable:

- Flexible synchronization
- Sequence number comparison and stop (Stop operation cannot be performed for a sequence number in AI high-precision contour control, AI nano high-precision contour control, or 5-axis control mode.)
- Index table indexing
- Retrace function (Do not use the retrace function in AI high-precision contour control or AI nano high-precision contour control, or in a program using 5-axis control mode.)
- Rotary axis control
- Gentle curve normal direction control
- Tool life management (The life value is counted. Do not specify a function related to tool life management, however.)
- Macro executor (execution macro)
- Manual handle interruption
- One-digit F code feed (The feedrate cannot be changed with a manual handle.)
- External deceleration (No external deceleration is performed.)

Restriction 5

Specifying one of the following functions in 5-axis control mode causes a PS alarm:

- Move command with the M, S, T, or B code
- NURBS interpolation G06.2
- Setting a workpiece coordinate system
G54, G54.1, G55, G56, G57,
G58, G59
- Canned cycle G73 to G79, G80, G81 to G89,
G98, G99
- Manual operation interruption
- Tool retraction and return

Restriction 6

Specifying the following function in 5-axis control mode causes a warning:

- MDI intervention

Restriction 7

If either of the following functions is used, the RISC board is unavailable:

- Angular axis control
- Arbitrary angular axis control

Restriction 8

Some combinations of NC commands may be restricted. Refer to the manual for each function.

7.1.20 High-speed Linear Interpolation (M series)

General

The high-speed linear interpolation function processes a move command related to a controlled axis not by ordinary linear interpolation but by high-speed linear interpolation. This function enables the high-speed execution of an NC program including a series of very small amounts of travel.

- **High-speed linear interpolation mode**

The high-speed linear interpolation start command G05 P2 places the system in high-speed linear interpolation mode, in which high-speed linear interpolation is executed. The high-speed linear interpolation end command G05P0 places the system in standard NC program operation mode.

At power-up or in the NC reset state, the system enters standard NC program operation mode.

After the end of high-speed linear interpolation mode, the system enters standard NC program operation mode.

- **Cutting feedrate**

Specify a cutting feedrate in high-speed linear interpolation mode. If no cutting feedrate is specified, the modal F value is assumed.

Maximum feedrate	Interpolation period: 8 ms	Interpolation period: 4 ms
(IS-B mm input)	122848 mm/min	245696 mm/min
(IS-B inch input)	12284.8 inch/min	24569.6 inch/min
(IS-C mm input)	12284 mm/min	24569 mm/min
(IS-C inch input)	1228.48 inch/min	2456.96 inch/min

$$\text{(Maximum feedrate)} = 122,848 \times 8 / (\text{interpolation period}) \text{ (IS-B, metric input)}$$

Minimum feedrate	Interpolation period: 8 ms	Interpolation period: 4 ms
(IS-B mm input)	4 mm/min	8 mm/min
(IS-B inch input)	0.38 inch/min	0.76 inch/min
(IS-C mm input)	4 mm/min	8 mm/min
(IS-C inch input)	0.38 inch/min	0.76 inch/min

$$\text{(Minimum feedrate)} = 4 \times 8 / (\text{interpolation period}) \text{ (IS-B, metric input)}$$

- **Interpolation period**

In high-speed linear interpolation mode, the NC interpolation period can be changed. As the interpolation period decreases, the machining speed and precision increase.

IT2, IT1, and IT0 bits (bits 6, 5, and 4 of parameter 7501)

IT2	IT1	IT0	Interpolation period
0	0	0	8 ms in high-speed linear interpolation mode
0	1	0	4 ms in high-speed linear interpolation mode
0	0	1	2 ms in high-speed linear interpolation mode
0	1	1	1 ms in high-speed linear interpolation mode
1	1	1	0.5 ms in high-speed linear interpolation mode

- **Acceleration/
deceleration processing
in high-speed linear
interpolation mode**

In high-speed linear interpolation mode, acceleration/deceleration before interpolation is not effective. Acceleration/deceleration after interpolation is enabled or disabled by setting SUP (bit 0 of parameter No.7502). When the interpolation period is set to 4 ms or less, the time constant for linear acceleration/deceleration after interpolation and bell-shaped acceleration/deceleration after interpolation is restricted as follows:

Time constant for linear acceleration/deceleration after interpolation and bell-shaped acceleration/deceleration after interpolation (parameter No.1628)

Interpolation period 8 ms: Maximum setting = 512 ms
 Interpolation period 4 ms: Maximum setting = 256 ms
 Interpolation period 2 ms: Maximum setting = 128 ms
 Interpolation period 1 ms: Maximum setting = 064 ms
 Interpolation period 0.5 ms: Maximum setting = 032 ms

Parameter

	#7	#6	#5	#4	#3	#2	#1	#0
7501		IT2	IT1	IT0				

[Data type] Bit

IT2 IT1 IT0

- 0 0 0 : The interpolation period in high-speed linear interpolation mode is 8 ms.
- 0 1 0 : The interpolation period in high-speed linear interpolation mode is 4 ms.
- 0 0 1 : The interpolation period in high-speed linear interpolation mode is 2 ms.
- 0 1 1 : The interpolation period in high-speed linear interpolation mode is 1 ms.
- 1 1 1 : The interpolation period in high-speed linear interpolation mode is 0.5 ms.

	#7	#6	#5	#4	#3	#2	#1	#0
7502								SUP

[Data type] Bit

- SUP** 0 : Acceleration/deceleration processing is disabled in high-speed linear interpolation mode.
- 1 : Acceleration/deceleration after interpolation is enabled in high-speed linear interpolation mode.

7510	Number of controlled axes in high-speed linear interpolation mode
------	---

[Data type] Byte

[Unit of data] Number of controlled axes

[Valid data range] 1 to 4

This parameter sets the number of axes controlled in high-speed linear interpolation mode.

Reference item

Series 16i/18i/160i/180i/ 160is/180is	OPERATOR'S MANUAL (For Machining Center) (B-63534EN)	II.19.8	High-speed linear interpolation
---	--	---------	---------------------------------

7.1.21 Look-ahead Bell-Shaped Acceleration/ Deceleration Before Interpolation Time Constant Change Function (M Series)

General

In Look-ahead bell-shaped acceleration/deceleration before interpolation, the speed during acceleration/deceleration is as shown in the figure below.

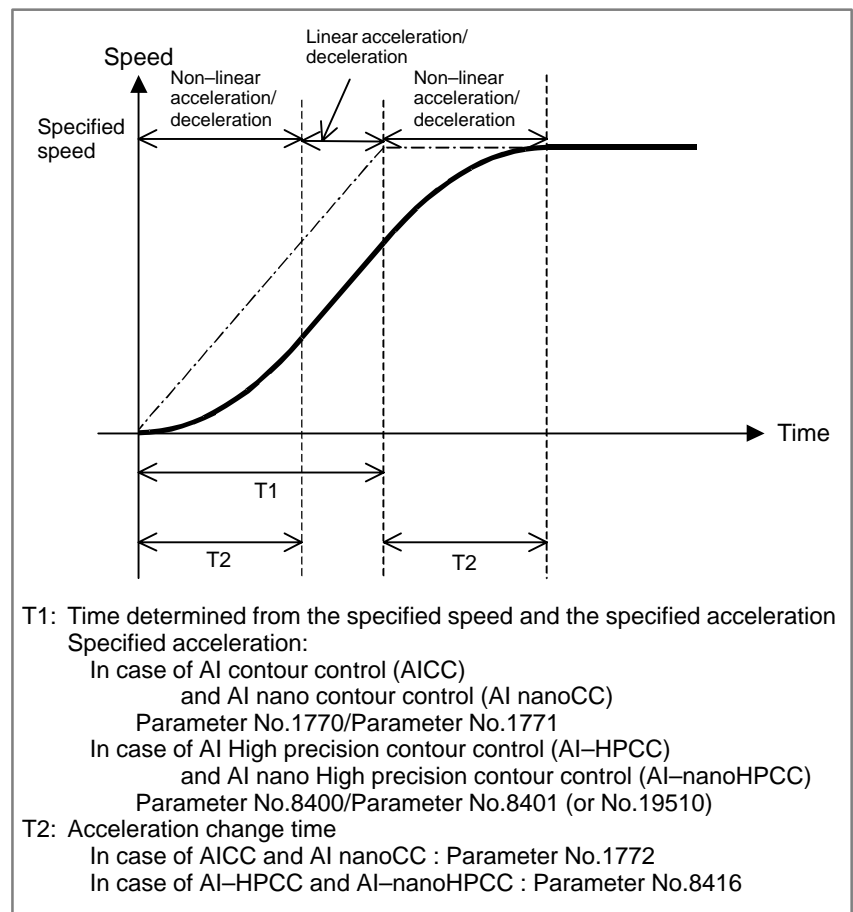

Fig. 7.1.21(a)

The time T1, shown above, varies with the specified speed. If the specified speed is low, the speed will be as shown below, causing linear acceleration/deceleration not reaching the specified acceleration.

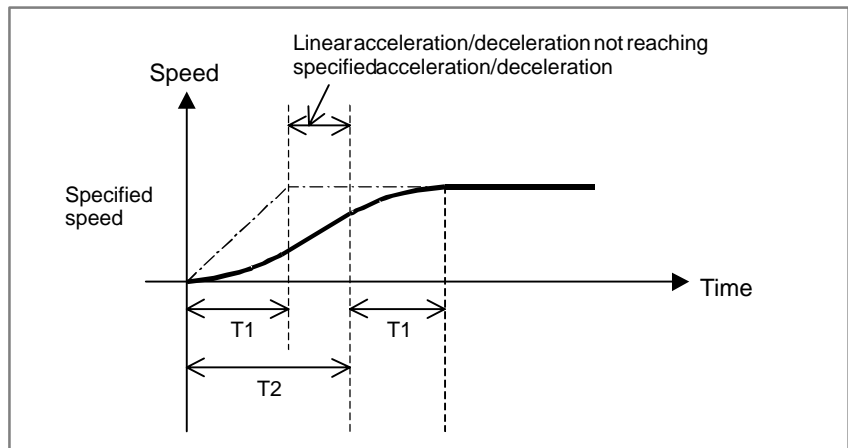

Fig. 7.1.21(b)

If linear acceleration/deceleration not reaching the specified acceleration occurs in AI contour control (AICC) mode or AI Nano contour control (AI nanoCC) mode or AI High Precision Contour control (AI-HPCC) mode or AI Nano High Precision Contour control (AI-nanoHPCC) mode as shown above, this function shortens the acceleration/deceleration time by changing the internal acceleration for acceleration/deceleration before interpolation and the bell-shaped time constant in order to generate an acceleration/deceleration pattern as close as possible to that permits optimum bell-shaped acceleration/deceleration before interpolation for the specified speed.

Optimum bell-shaped acceleration/deceleration before interpolation, as mentioned here, refers to bell-shaped acceleration/deceleration before interpolation in which

if $T2 > T1$, $T1$ and $T2$ are changed to $T1'$ and $T2'$ as shown in the figure below so that linear acceleration/deceleration not reaching the specified acceleration/deceleration does not occur.

This function becomes effective for the Acceleration /deceleration before look-ahead interpolation in AI contour control mode or AI Nano contour control mode or AI High Precision Contour control mode or AI Nano Contour control mode..

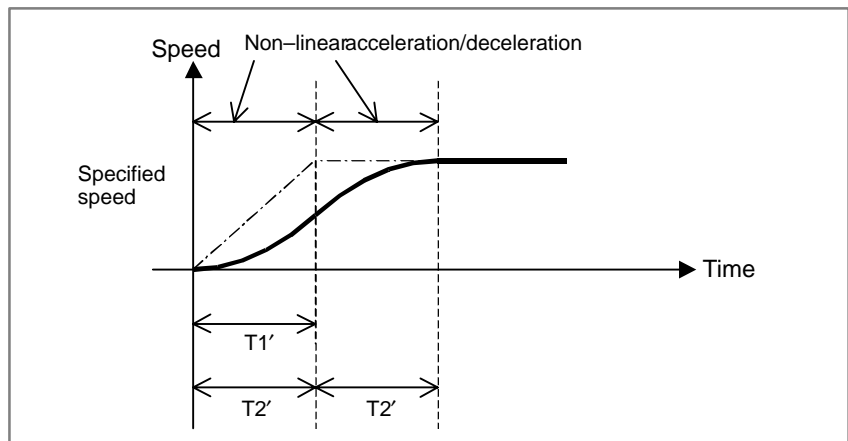

Fig. 7.1.21(c)

Description

• Methods of specifying the acceleration/deceleration reference speed

The acceleration/deceleration reference speed is the feedrate used as the reference for calculating optimum acceleration. In Fig. 7.1.21(c), it is equivalent to the specified speed used to determine T1' and T2'. There are three methods for specifying the acceleration/deceleration reference speed.

- (1) Specifying the speed using an F in a G05.1 Q1 (AICC or AI nanoCC) block or G05 P10000 (AI-HPCC or AI-nanoHPCC) block
- (2) Setting the speed on Parameter
- (3) Setting the speed specified with the F command issued at the start of cutting as the reference speed

NOTE

This function is effective if BCG (No. 7055 bit 3) is 1 in AI contour control mode or AI Nano contour control mode, or if BCG (No.19501#6) is 1 in AI High Precision Contour control mode or AI Nano High Precision Contour control mode.

(1) Specifying the speed in a G05.1 Q1 block or G05 P10000 block

If an F command is used in a G05.1 Q1 (AICC or AI nanoCC) block or G05 P10000 (AI-HPCC or AI-nanoHPCC) block, the speed specified with the F command is assumed the acceleration/deceleration reference speed.

This acceleration/deceleration reference speed is cleared upon a reset. After the acceleration/deceleration reference speed is cleared upon a reset or after the power is turned off and then on again, the acceleration/deceleration reference speed specified for parameter No. 7066 (AICC or AI nanoCC) or No.19520 (AI-HPCC or AI-nanoHPCC) will be used. (Method (2), described later)

If the acceleration/deceleration reference speed specified for the parameter is 0, the feedrate assumed at the start of cutting will be assumed the acceleration/deceleration reference speed. (Method (3), described later)

(Program example)

```
G05.1 Q1 F5000 ; ...Sets the reference speed to 5000 mm/min.
```

The F command used in a G05.1 block is used to specify the acceleration/deceleration reference speed, and is also used as a normal F command.

Even if the feedrate is changed during the execution of the machining program, the acceleration/deceleration reference speed specified with the above command remains in effect. If this occurs, the machining time may become longer because machining is performed at the feedrate different from the acceleration/deceleration reference speed.

For this reason, the acceleration/deceleration reference speed to be specified with the above command should be as close as possible to the actual machining speed.

NOTE

The G05.1Q1Fxxxx, G05P10000Fxxxx command must be issued in feed per minute (G94) mode.
If this command is issued in another mode, the speed specified with this command will be generated the alarm(PS5111).

(2) Setting the speed on the Parameter

The acceleration/deceleration reference speed is set in parameter No. 7066(AICC or AI nanoCC) or No.19520(AI-HPCC or AI-nanoHPCC). Because these parameters must be set in input unit, when the input unit is changed, these parameters must be changed.

This method is used if the G05.1Q1 block or G05 P10000 block does not have an F command.

(3) Using the speed specified with the F command issued at the start of cutting as the reference speed

The speed specified with the F command issued when a cutting block group (such as G01 and G02) starts is assumed the acceleration/deceleration reference speed,

This method is used if the G05.1Q1 block or G05 P10000 block does not have an F command and the parameter of the acceleration/deceleration reference speed is set to 0.

```
G05.1Q1;
(G00)
G01 X— Y— Z— F*** ;
X— Y— Z—
X— Y— Z—
X— Y— Z—
G00 ;
G05.1Q0 ;
```

} Cutting block group

Even if an F command is issued before a cutting block group and the F command is effective to the cutting block group modally, the speed specified with the modal F effective at the start of cutting will be assumed the acceleration/deceleration reference speed.

● **Acceleration/deceleration parameter calculation method**

Optimum bell-shaped acceleration/deceleration before interpolation, as mentioned here, refers to bell-shaped acceleration/deceleration before interpolation in which linear acceleration/deceleration not reaching the specified acceleration/deceleration does not occur if $T2 > T1$. Calculation is performed as described below.

- (1) If the bell-shaped acceleration/deceleration before interpolation time constant T2' is calculated under the condition that the bell-shaped acceleration/deceleration before interpolation must not have a linear portion,

$$T2' = \sqrt{\frac{T2 \times F}{A}}$$

T2: Acceleration change time specified for bell-shaped acceleration/deceleration before interpolation

F: Acceleration/deceleration reference speed

A: Acceleration for the acceleration/deceleration before interpolation

- (2) A proper acceleration is determined under the condition that the acceleration change must be about the same as the setting so that parameter changes do not cause considerable shock to the machine, that is:

$$\frac{\text{Acceleration after change}}{\text{Acceleration change time after change}} = \frac{\text{Acceleration before change}}{\text{Acceleration change time before change}}$$

The acceleration change time is regarded to be the sum of the acceleration change time of bell-shaped acceleration/deceleration and the time constant of acceleration/deceleration after interpolation, and the acceleration A' for the acceleration/deceleration before interpolation is determined as follows:

$$A' = A \times \frac{T2' + Tc}{T2 + Tc}$$

A: Acceleration for the acceleration/deceleration before interpolation

Tc: Time constant of acceleration/deceleration after interpolation

Acceleration/deceleration is performed using T2' and A', determined as described above.

Parameter

	#7	#6	#5	#4	#3	#2	#1	#0
7055					BCG			

[Input type] Parameter input

[Data type] Bit type

#3 BCG The bell-shaped acceleration/deceleration time constant change function in AI Contour control mode or AI Nano contour control mode is:

0 : Disabled.

1 : Enabled.

In AI High Precision Contour control mode or AI Nano High Precision Contour control mode, parameter BCG (No.19501#6) should be set.

7066	Acceleration/deceleration reference speed for the bell-shaped acceleration/deceleration time constant change function in AI Contour control mode or AI Nano contour control mode
------	--

[Input type] Parameter input

[Data type] 2 word

[Unit of data] [Minimum data unit]	Increment system	Unit of data	Valid range	
			IS-B	IS-C
	Millimeter input	1 mm/min	0 to 600000	0 to 60000
	Inch input	0.1 inch/min	0 to 600000	0 to 60000

[Valid data range] Acceleration/deceleration reference speed for the bell-shaped acceleration/deceleration time constant change function in AI Contour control mode or AI Nano contour control mode is set on this parameter. When the input unit is changed, this parameter must be changed. In AI High Precision Contour control mode or AI Nano High Precision Contour control mode, parameter No.19520 should be set.

	#7	#6	#5	#4	#3	#2	#1	#0
19501		BCG						

[Input type] Parameter input

[Data type] Bit type

#6 BCG The bell-shaped acceleration/deceleration time constant change function in AI High Precision Contour control mode or AI Nano High Precision contour control mode is:

- 0 : Disabled.
- 1 : Enabled.

In AI contour control mode or AI Nano contour control mode, parameter BCG (No. 7055 bit 3) should be set.

19520	Acceleration/deceleration reference speed for the bell-shaped acceleration/deceleration time constant change function in AI High Precision Contour control mode or AI Nano High Precision contour control mode
-------	--

[Input type] Parameter input

[Data type] 2 word

[Unit of data] [Minimum data unit]	Increment system	Unit of data	Valid range	
			IS-B	IS-C
	Millimeter input	1 mm/min	0 to 600000	0 to 60000
	Inch input	0.1 inch/min	0 to 600000	0 to 60000

[Valid data range] Acceleration/deceleration reference speed for the bell-shaped acceleration/deceleration time constant change function in AI High Precision Contour control mode or AI Nano High Precision contour control mode is set on this parameter. When the input unit is changed, this parameter must be changed. In AI contour control mode or AI Nano contour control mode, parameter No. 7066 should be set.

7.2 ACCELERATION/ DECELERATION CONTROL

7.2.1 Automatic Acceleration/ Deceleration

7.2.1.1 Automatic acceleration/ deceleration

General

- Automatic acceleration/
deceleration

To prevent a mechanical shock, acceleration/deceleration is automatically applied when the tool starts and ends its movement (Fig. 7.2.1.1).

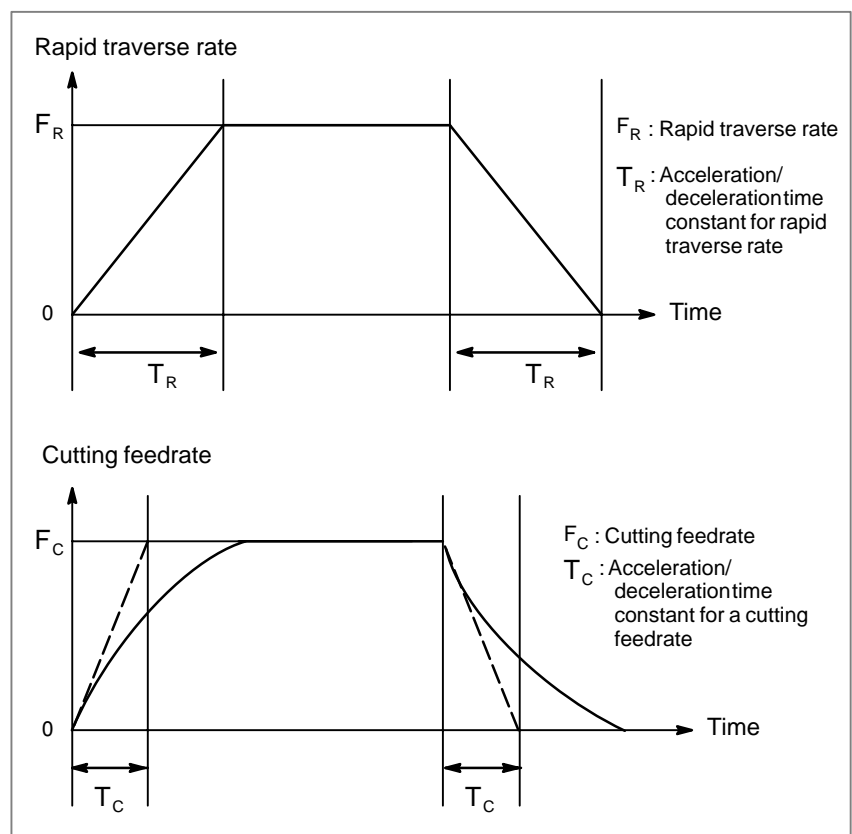

Fig. 7.2.1.1 Automatic acceleration/deceleration (example)

Acceleration and deceleration is performed when starting and ending movement, resulting in smooth start and stop.

Automatic acceleration/deceleration is also performed when feedrate changes, so the change in speed is also smooth.

It is not necessary to take acceleration/deceleration into consideration when programming.

Rapid traverse: Linear acceleration/deceleration (time constant per axis is set by parameter 1620)

Cutting feed: Exponential acceleration/deceleration (time constant per axis is set by parameter 1622)

Jog feed : Exponential acceleration/deceleration (time constant per axis is set by parameter 1624)

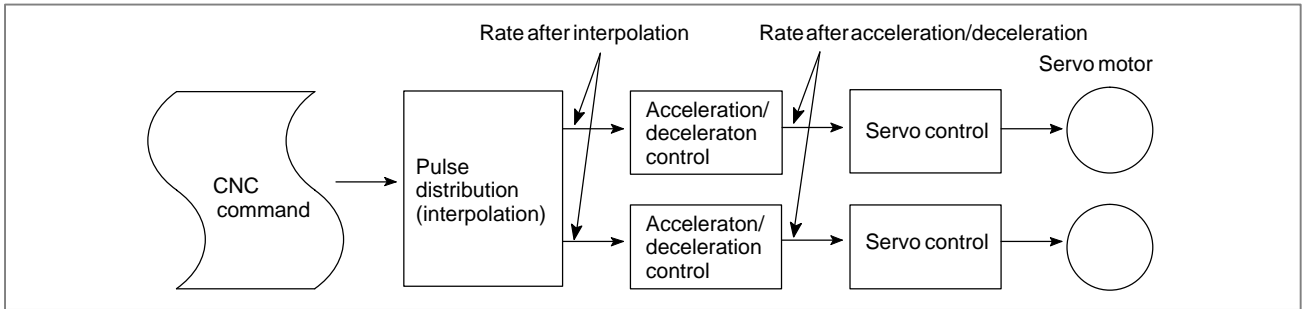

Parameter

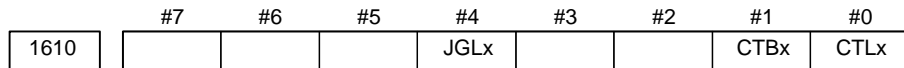

[Data type] Bit axis

CTLx Acceleration/deceleration in cutting feed including feed in dry run

0 : Exponential acceleration/deceleration is applied.

1 : Linear acceleration/deceleration after interpolation is applied.

NOTE

If the optional function of linear acceleration/deceleration after interpolation in cutting feed is not provided, exponential acceleration/deceleration is used irrespective of this setting.

To use bell-shaped acceleration/deceleration after interpolation, set this parameter to 0 and select the acceleration/deceleration using CTBx, bit 1 of parameter No. 1610.

Parameter		Acceleration/deceleration
CTBx	CTLx	
0	0	Exponential acceleration/deceleration
0	1	Linear acceleration/deceleration after interpolation
1	0	Bell-shaped acceleration/deceleration after interpolation

CTBx Acceleration/deceleration in cutting feed including feed in dry run

0 : Exponential acceleration/deceleration or linear acceleration/deceleration after interpolation is applied (depending on the setting in CTLx, bit 0 of parameter No. 1610).

1 : Bell-shaped acceleration/deceleration after interpolation is applied.

NOTE

This parameter is effective only when the function of bell-shaped acceleration/deceleration after interpolation in cutting feed is provided. If the function is not provided, the setting in CTLx, bit 0 of parameter No. 1610, determines the type of acceleration/deceleration irrespective of the setting in this parameter.

JGLx Acceleration/deceleration in manual continuous feed (jog feed)

0 : Exponential acceleration/deceleration is applied.

1 : Linear acceleration/deceleration after interpolation or bell-shaped acceleration/deceleration after interpolation is applied (depending on which is used for cutting feed).

1620

Time constant used for linear acceleration/deceleration or bell-shaped acceleration/deceleration in rapid traverse for each axis

[Data type] Word axis

[Unit of data] ms

[Valid data range] 0 to 4000

Specify a time constant used for acceleration/deceleration in rapid traverse. When the optional function of bell-shaped acceleration/deceleration in rapid traverse is provided, bell-shaped acceleration/deceleration is applied in rapid traverse. If the function is not provided, linear acceleration/deceleration is applied.

(1) When the function is provided, set this parameter to time constant T1 used in bell-shaped acceleration/deceleration in rapid traverse, and set parameter No. 1621 to time constant T2.

(2) When the function is not provided, specify a time constant used in linear acceleration/deceleration.

NOTE

When parameter No. 1621 (time constant T2 used for bell-shaped acceleration/deceleration in rapid traverse) is set to 0, linear acceleration/deceleration is applied in rapid traverse even if the function is provided. In this case, this parameter stands for a time constant used in linear acceleration/deceleration in rapid traverse.

1622

Time constant of exponential acceleration/deceleration or linear acceleration/deceleration after interpolation or bell-shaped acceleration/deceleration after interpolation, in cutting feed for each axis

[Data type] Word axis

[Unit of data] ms

[Valid data range] 0 to 4000 (For exponential acceleration / deceleration)
0 to 512 (For linear acceleration / deceleration after interpolation or bell-shaped acceleration/deceleration after interpolation)

Set the time constant used for exponential acceleration/deceleration or linear acceleration/deceleration after interpolation or bell-shaped acceleration/deceleration after interpolation in cutting feed for each axis. Except for special applications, the same time constant must be set for all axes in this parameter. If the time constants set for the axes differ from each other, proper straight lines and arcs cannot be obtained.

1623 FL rate of exponential acceleration/deceleration in cutting feed for each axis

[Data type] Word axis

[Unit of data]	Increment system	Unit of data	Valid data range	
			IS-A, IS-B	IS-C
[Valid data range]	Millimeter machine	1 mm/min	0, 6 – 15000	0, 6 – 12000
	Inch machine	0.1 inch/min	0, 6 – 6000	0, 6 – 4800
	Rotation axis	1 deg/min	0, 6 – 15000	0, 6 – 12000

Set the lower limit (FL rate) of exponential acceleration/deceleration in cutting feed for each axis. Except for special applications, this parameter must be set to 0 for all axes. If a value other than 0 is specified, proper straight lines and arcs cannot be obtained.

1624 Time constant of exponential acceleration/deceleration, bell-shaped acceleration/deceleration after interpolation or linear acceleration/deceleration after interpolation, in jog feed for each axis.

[Data type] Word axis

[Unit of data] ms

[Valid data range] 0 to 4000 (For exponential acceleration / deceleration)
0 to 512 (For linear acceleration / deceleration after interpolation or bell-shaped acceleration/deceleration after interpolation)

Set the time constant used for exponential acceleration/deceleration, bell-shaped acceleration/deceleration after interpolation or linear acceleration/deceleration after interpolation in jog feed for each axis. The type of acceleration/deceleration is determined depending on the setting in parameter No. 1610.

1625 FL rate of exponential acceleration/deceleration in jog feed for each axis

[Data type] Word axis

[Unit of data]	Increment system	Unit of data	Valid data range	
			IS-A, IS-B	IS-C
[Valid data range]	Millimeter machine	1 mm/min	6 – 15000	6 – 12000
	Inch machine	0.1 inch/min	6 – 6000	6 – 4800
	Rotation axis	1 deg/min	6 – 15000	6 – 12000

Set the lower limit (FL rate) of exponential acceleration/deceleration in jog feed for each axis.

1626	Time constant of exponential acceleration/deceleration in the thread cutting cycle for each axis

[Data type] Word axis

[Unit of data] ms

[Valid data range] 0 to 4000

Set the time constant used for exponential acceleration/deceleration in the thread cutting cycle (G76, G78 (G92 in G code system A)) for each axis.

1627	FL rate of exponential acceleration/deceleration in the thread cutting cycle for each axis

[Data type] Word axis

[Unit of data]

[Valid data range]

Increment system	Unit of data	Valid data range	
		IS-A, IS-B	IS-C
Millimeter machine	1 mm/min	6 – 15000	6 – 12000
Inch machine	0.1 inch/min	6 – 6000	6 – 4800
Rotaion axis	1 deg/min	6 – 15000	6 – 12000

Set the lower limit (FL rate) of exponential acceleration/deceleration in the thread cutting cycle (G76, G78 (G92 in G code system A)) for each axis.

7.2.1.2

Rapid traverse block overlap

General

Rapid traverse blocks may be arranged successively or a rapid traverse block may be followed by a block that does not cause movement. In this case, execution of the next block can be started when the feedrate for each axis of the rapid traverse block is decreased to the deceleration ratio specified in the parameter.

Signal

Rapid traverse block overlap disable signal ROVLP <G0053#5>

[Classification] Input signal

[Function] This signal disables rapid traverse block overlap.

Signal address

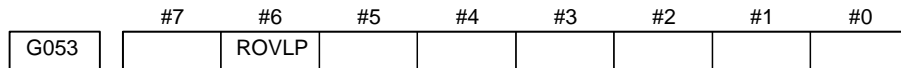

Parameter

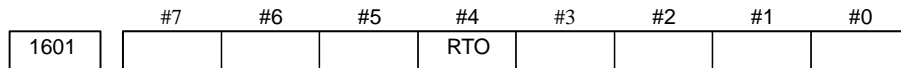

[Data type] Bit

RTO Rapid traverse block overlap is:

0 : Not performed.

1 : Performed.

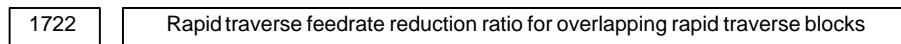

[Data type] Byte axis

[Unit of data] %

[Valid data range] 0 to 100

This parameter is used when rapid traverse blocks are arranged successively, or when a rapid traverse block is followed by a block that does not cause movement. When the feedrate for each axis of a block is reduced to the ratio set in this parameter, the execution of the next block is started.

NOTE

The parameter No. 1722 is effective when parameter No. 1601 #4 (RTO) is set to 1.

Example

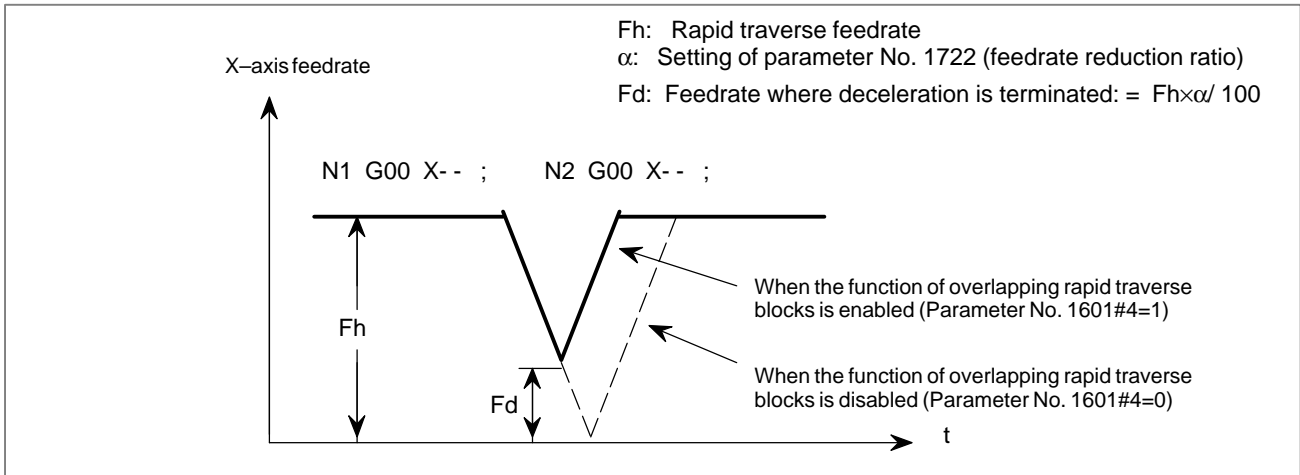

**7.2.2
Rapid Traverse
Bell-shaped
Acceleration/
Deceleration**

General

Rapid traverse bell-shaped acceleration/deceleration smoothly increases or decreases the rapid traverse rate, reducing the stress and strain imposed on the machine due to the variation in the acceleration with changes in the feedrate. As the time constant for bell-shaped acceleration/deceleration can be smaller than that for linear acceleration/deceleration, the time needed for acceleration/deceleration can be reduced.

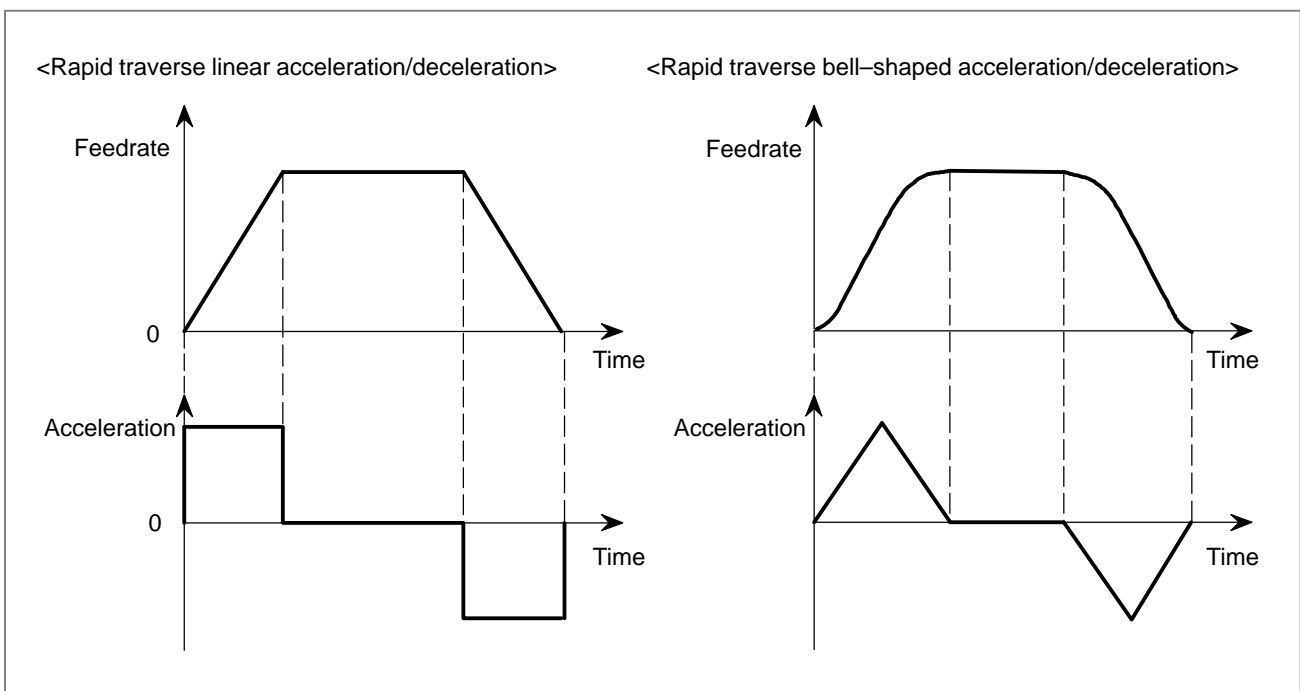

This function is enabled when the time constants for rapid traverse bell-shaped acceleration/deceleration T_1 and T_2 are specified in parameter Nos. 1620 and 1621, respectively.

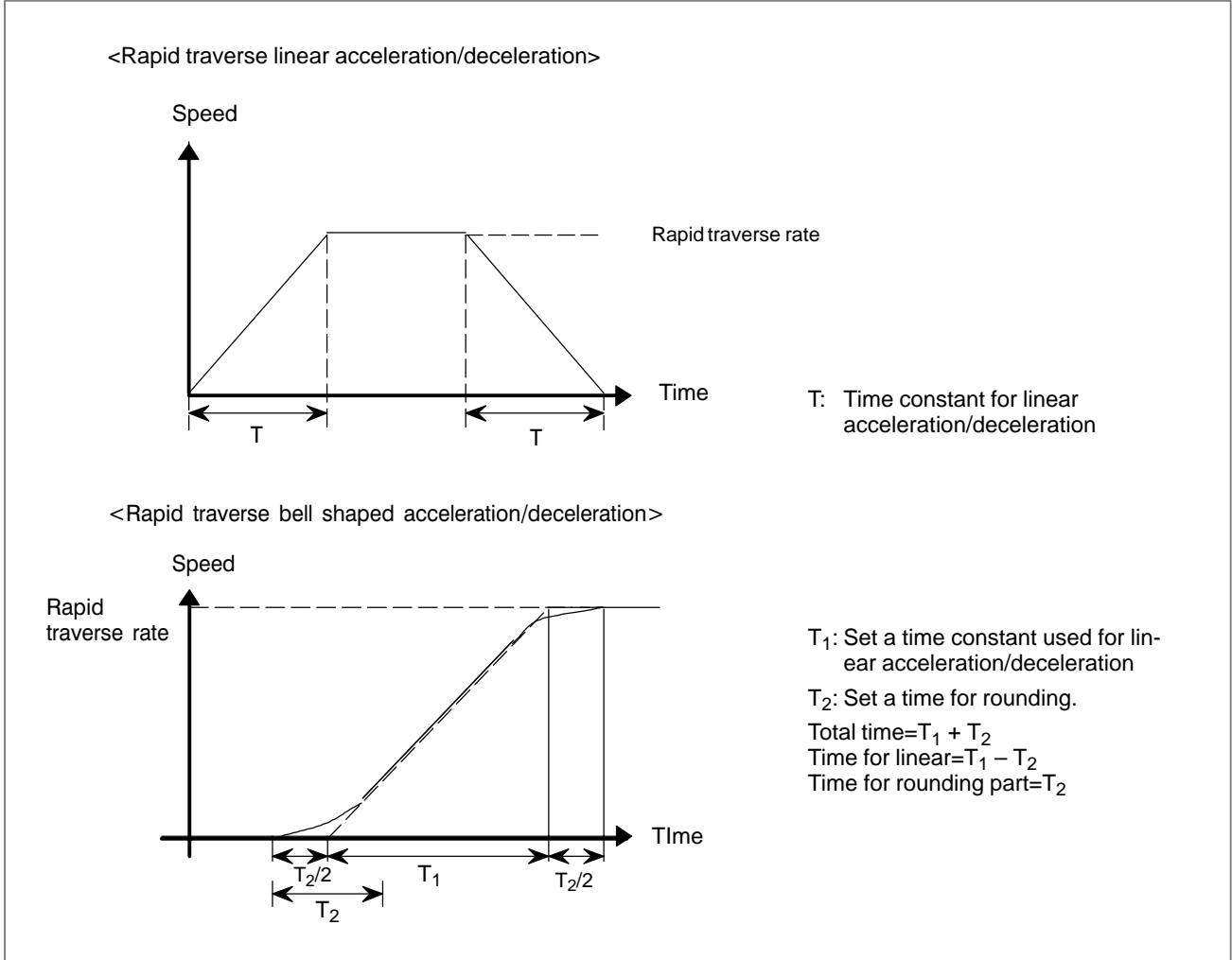

Set a time when rapid traverse override is 100% . When it is less than 100%, the total time is reduced (constant acceleration method).

Value of T_1 is determined from motor torque. Set a value of T_2 to 24 ms or 32 ms.

Parameter

1620	Time constant used in linear acceleration/deceleration or bell-shaped acceleration/deceleration in rapid traverse for each axis
------	---

[Data type] Word axis

[Unit of data] ms

[Valid data range] 0 to 4000

Specify a time constant used for acceleration/deceleration in rapid traverse. When the optional function of bell-shaped acceleration/deceleration in rapid traverse is provided, bell-shaped acceleration/deceleration is applied in rapid traverse. If the function is not provided, linear acceleration/deceleration is applied.

- When the function is provided, set this parameter to time constant T1 used in bell-shaped acceleration/deceleration in rapid traverse, and set parameter No. 1621 to time constant T2.
- When the function is not provided, specify a time constant used for linear acceleration/deceleration.

NOTE

When parameter No. 1621 (time constant T2 used for bell-shaped acceleration/deceleration in rapid traverse) is set to 0, linear acceleration/deceleration is applied in rapid traverse even if the Bell-shaped acceleration/deceleration in rapid traverse is provided. In this case, this parameter stands for a time constant used for linear acceleration/deceleration in rapid traverse.

1621

Time constant t T2 used for bell-shaped acceleration/deceleration in rapid traverse for each axis

[Data type] Word axis

[Unit of data] ms

[Valid data range] 0 to 512

Specify time constant T2 used for bell-shaped acceleration/deceleration in rapid traverse for each axis.

NOTE

- 1 This parameter is effective when the function of bell-shaped acceleration/deceleration in rapid traverse is provided. Set parameter No. 1620 to time constant T1 used for bell-shaped acceleration/deceleration in rapid traverse, and set this parameter to time constant T2. For details of time constants T1 and T2, see the general description in this section.
- 2 When this parameter is set to 0, linear acceleration/deceleration is applied in rapid traverse. The setting in parameter No. 1620 is used as a time constant in linear acceleration/deceleration.

Reference item

CONNECTION MANUAL (This manual)	7.2.1	AutomaticAcceleration/Deceleration
------------------------------------	-------	------------------------------------

7.2.3 Linear Acceleration/ Deceleration after Cutting Feed Interpolation

General

If linear acceleration/deceleration after interpolation for cutting feed is enabled (bit 0 of parameter No. 1610, CTL), acceleration/deceleration is performed as follows:

Cutting feed: Linear acceleration/deceleration (constant acceleration time)

Specify the acceleration/deceleration time constant for each axis in parameter No. 1622.

Jog feed: Exponential or linear acceleration/deceleration (constant acceleration time)

Specify the acceleration/deceleration time constant for each axis in parameter No. 1624.

If an identical time constant is specified, linear acceleration/deceleration can halve the delay relative to the programmed time, in comparison with exponential acceleration/deceleration, thus reducing the time needed for acceleration and deceleration. If circular interpolation is performed, especially when high-speed cutting is being performed, the actual tool path created after acceleration/deceleration will deviate from the programmed arc in the radial direction. This deviation can also be reduced, in comparison with exponential acceleration/deceleration, by applying linear acceleration/deceleration.

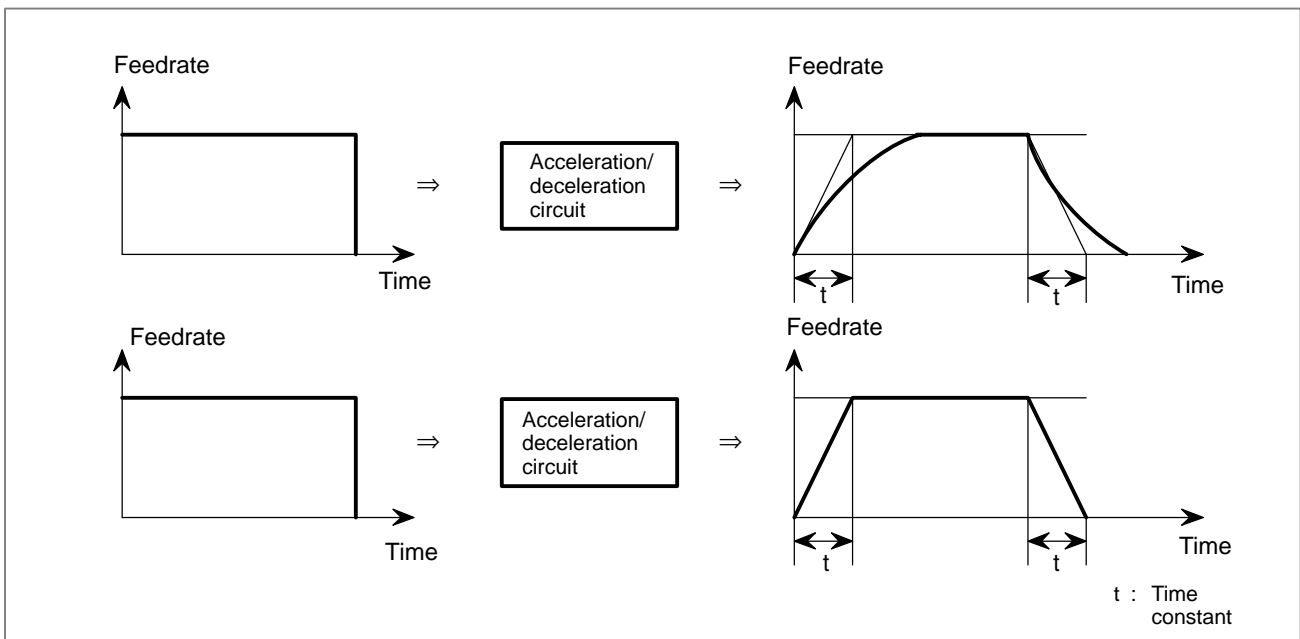

Linear acceleration/deceleration after cutting feed interpolation is an optional function. This function is enabled when the CTL bit (bit 0 of parameter No. 1610) is specified. If bell-shaped acceleration/deceleration after interpolation for cutting feed is also enabled, bell-shaped acceleration/deceleration is executed. The time constants for cutting feed and jog feed for each axis are specified in parameter Nos. 1622 and 1624 respectively, in the same way as for exponential acceleration/deceleration. The values specified for the FL feedrate for cutting feed (parameter No. 1623) and the FL feedrate for jog feed (parameter No. 1625) are ignored (always assumed to be 0).

Parameter

	#7	#6	#5	#4	#3	#2	#1	#0
1610				JGLx				CTLx

[Data type] Bit axis

CTLx Acceleration/deceleration in cutting feed including feed in dry run

0 : Exponential acceleration/deceleration is applied.

1 : Linear acceleration/deceleration after interpolation is applied.

Parameter		Acceleration/deceleration
CTBx	CTLx	
0	0	Exponential acceleration/deceleration
0	1	Linear acceleration/deceleration after interpolation
1	0	Bell-shaped acceleration/deceleration after interpolation

JGLx Acceleration/deceleration in manual continuous feed (jog feed)

0 : Exponential acceleration/deceleration is applied.

1 : Linear acceleration/deceleration after interpolation or bell-shaped acceleration/deceleration after interpolation is applied (depending on which is used in cutting feed).

1622	Time constant of exponential acceleration/deceleration, linear acceleration/deceleration after interpolation or bell-shaped acceleration/deceleration after interpolation, in cutting feed for each axis
------	--

[Data type] Word axis

[Unit of data] ms

[Valid data range] 0 to 4000 (For exponential acceleration/deceleration)
0 to 512 (For linear acceleration/deceleration after interpolation or bell-shaped acceleration/deceleration after interpolation)

Set the time constant used for exponential acceleration/deceleration, linear acceleration/deceleration after interpolation or bell-shaped acceleration/deceleration after interpolation in cutting feed for each axis. Except for special applications, the same time constant must be set for all axes in this parameter. If the time constants set for the axes differ from each other, proper straight lines and arcs cannot be obtained.

1624

Time constant of exponential acceleration/deceleration, bell-shaped acceleration/deceleration after interpolation or linear acceleration/deceleration after interpolation, in jog feed for each axis.

[Data type] Word axis

[Unit of data] ms

[Valid data range] 0 to 4000 (For exponential acceleration/deceleration)
0 to 512 (For linear acceleration/deceleration after interpolation or bell-shaped acceleration/deceleration after interpolation)

Set the time constant used for exponential acceleration/deceleration, bell shaped acceleration/deceleration after interpolation or linear acceleration/deceleration after interpolation in jog feed for each axis.

The type of acceleration/deceleration is determined depending on the setting in parameter No. 1610.

Note

NOTE

If the optional function for linear acceleration/deceleration after interpolation for cutting feed is not provided, exponential acceleration/deceleration is always selected, irrespective of the setting.

- 1 If linear acceleration/deceleration after interpolation for cutting feed is enabled, linear acceleration/deceleration is executed during cutting feed and during a dry run. Linear acceleration/deceleration can also be executed during jog feed if the JGL bit (bit 4 of parameter No. 1610) is specified accordingly.
- 2 In circular interpolation especially when circular cutting is executed at high speed, the actual path of the accelerated or decelerated tool deviates from the specified arc in the direction of the radius.

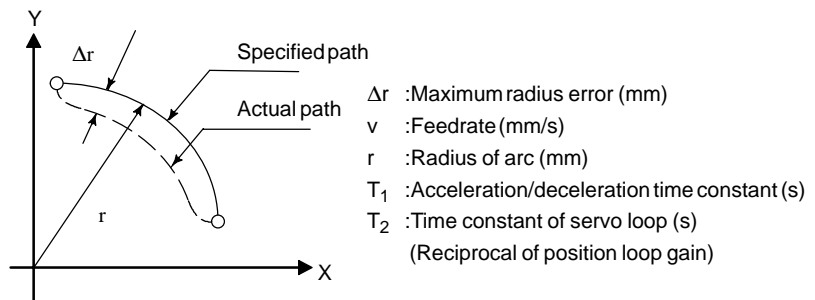

The maximum error in the radial direction (Δr) can be approximated by the following expressions:

$$\Delta r = \left(\frac{1}{2} T_1^2 + \frac{1}{2} T_2^2 \right) \frac{v^2}{r} \dots \text{Exponential acceleration/deceleration}$$

$$\Delta r = \left(\frac{1}{24} T_1^2 + \frac{1}{2} T_2^2 \right) \frac{v^2}{r} \dots \text{Linear acceleration/deceleration or bell shaped acceleration /deceleration after interpolation}$$

If the error caused by the time constant of the servo loop is excluded, the error cause by linear acceleration/ deceleration or bell shaped acceleration/deceleration after interpolation is 1/12 of that caused by exponential acceleration/deceleration.

- 3 Linear acceleration/deceleration can be executed both for cutting feed and for jog feed along a PMC axis. Acceleration/deceleration for cutting feed is executed even if acceleration/deceleration for jog feed is selected. In jog feed along the PMC axis, the time constant for cutting feed is used instead of that for jog feed.

7.2.4 Bell-Shaped Acceleration/ Deceleration after Cutting Feed Interpolation

General

The bell-shaped acceleration/deceleration after cutting feed interpolation provides smooth acceleration and deceleration to reduce stress and strain on the machine. If this function is enabled (bit 1 of parameter No. 1610, CTB), acceleration/deceleration is performed as follows:

Cutting feed: Bell-shaped acceleration/deceleration (constant acceleration time)

Specify the acceleration/deceleration time constant for each axis in parameter No. 1622.

Jog feed: Exponential or bell-shaped acceleration/deceleration (constant acceleration time)

Specify the acceleration/deceleration time constant for each axis in parameter No. 1624.

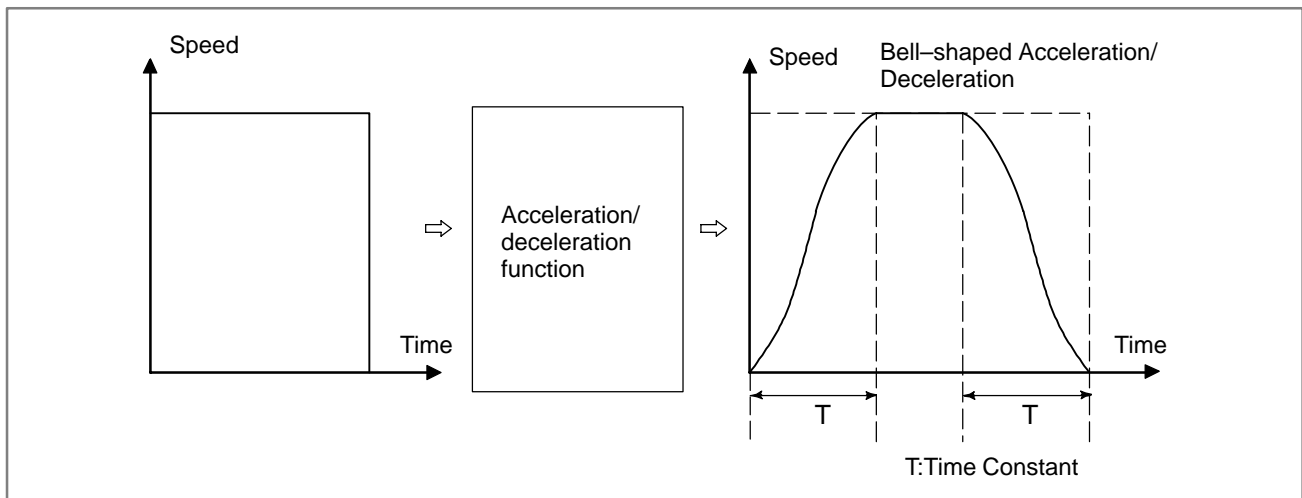

Bell-shaped acceleration/deceleration after cutting feed interpolation is an optional function. This function is enabled when the CTB bit (bit 1 of parameter No. 1610) is specified. The time constants for cutting feed and for jog feed for each axis are specified in parameter Nos. 1622 and 1624 respectively, in the same way as exponential acceleration/deceleration. The values specified for the FL feedrate for cutting feed (parameter No. 1623) and the FL feedrate for jog feed (parameter No. 1625) are ignored (always assumed to be 0).

Parameter



[Data type] Bit axis

CTLx Acceleration/deceleration in cutting feed including feed in dry run
 0 : Exponential acceleration/deceleration is applied.
 1 : Linear acceleration/deceleration after interpolation is applied.

NOTE
 If the optional function of linear acceleration/deceleration after interpolation in cutting feed is not provided, exponential acceleration/deceleration is used irrespective of this setting.
 To use bell-shaped acceleration/deceleration after interpolation, set this parameter to 0 and select the acceleration/deceleration using CTBx, bit 1 of parameter No. 1610.

Parameter		Acceleration/deceleration
CTBx	CTLx	
0	0	Exponential acceleration/deceleration
0	1	Linear acceleration/deceleration after interpolation
1	0	Bell-shaped acceleration/deceleration after interpolation

CTBx Acceleration/deceleration in cutting feed including feed in dry run
 0 : Exponential acceleration/deceleration or linear acceleration/deceleration after interpolation is applied (depending on the setting in CTLx, bit 0 of parameter No. 1610).
 1 : Bell-shaped acceleration/deceleration after interpolation is applied.

NOTE
 This parameter is effective only when the function of bell-shaped acceleration/deceleration after interpolation in cutting feed is provided. If the function is not provided, the setting in CTLx, bit 0 of parameter No. 1610, determines the type of acceleration/deceleration irrespective of the setting in this parameter.

JGLx Acceleration/deceleration in manual continuous feed (jog feed)
 0 : Exponential acceleration/deceleration is applied.
 1 : Linear acceleration/deceleration after interpolation or bell-shaped acceleration/deceleration after interpolation is applied (depending on which is used in cutting feed).

1622

Time constant of exponential acceleration/deceleration, linear acceleration/deceleration after interpolation or bell-shaped acceleration/deceleration after interpolation, in cutting feed for each axis

[Data type] Word axis

[Unit of data] ms

[Valid data range] 0 to 4000 (For exponential acceleration/deceleration)
0 to 512 (For linear acceleration/deceleration after interpolation or bell-shaped acceleration/deceleration after interpolation)

Set the time constant used for exponential acceleration/deceleration, linear acceleration/deceleration after interpolation or bell-shaped acceleration/deceleration after interpolation in cutting feed for each axis. Except for special applications, the same time constant must be set for all axes in this parameter. If the time constants set for the axes differ from each other, proper straight lines and arcs cannot be obtained.

<Bell-shaped acceleration/deceleration after cutting feed interpolation>

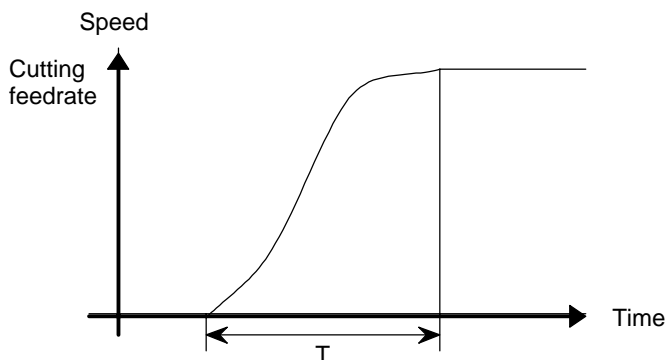

T : Total time. It is constant irrespective of feedrate. (Time constant is constant).

The curve corresponds to that $T_1 = T/2$ and $T_2 = T/2$ set in parameter No. 1620 and 1621. No linear part exists.

1624

Time constant of exponential acceleration/deceleration, bell-shaped acceleration/deceleration after interpolation or linear acceleration/deceleration after interpolation, in jog feed for each axis.

[Data type] Word axis

[Unit of data] ms

[Valid data range] 0 to 4000 (For exponential acceleration/deceleration)
0 to 512 (For linear acceleration/deceleration after interpolation or bell-shaped acceleration/deceleration after interpolation)

Set the time constant used for exponential acceleration/deceleration, bell-shaped acceleration/deceleration after interpolation or linear acceleration/deceleration after interpolation in jog feed for each axis. The type of acceleration/deceleration is determined depending on the setting in parameter No. 1610.

Note**NOTE**

- 1 If bell-shaped acceleration/deceleration after interpolation during cutting feed is enabled, bell-shaped acceleration/deceleration is executed during cutting feed and during a dry run. Bell-shaped acceleration/deceleration can also be executed during jog feed if the JGL bit (bit 4 of parameter No. 1610) is specified accordingly.
- 2 In circular interpolation, the actual tool path after acceleration/deceleration deviates from the programmed arc in the radial direction. To overcome this radial deviation, see the note on linear acceleration/deceleration after interpolation for cutting feed in Subsection 7.2.3.
- 3 Bell-shaped acceleration/deceleration can be executed both for cutting feed and for jog feed along a PMC axis. The time constant for acceleration/deceleration for jog feed is the same as that for cutting feed. In jog feed along the PMC axis, the time constant for cutting feed is used instead of that for jog feed.

7.2.5 Linear Acceleration/ Deceleration before Cutting Feed Interpolation

General

A specified cutting feedrate can be linearly increased or decreased before interpolation. This function eliminates machining profile errors caused by the delay occurring in acceleration or deceleration. The time required for acceleration or deceleration by this function is significantly shorter than that by the function of exponential acceleration/deceleration.

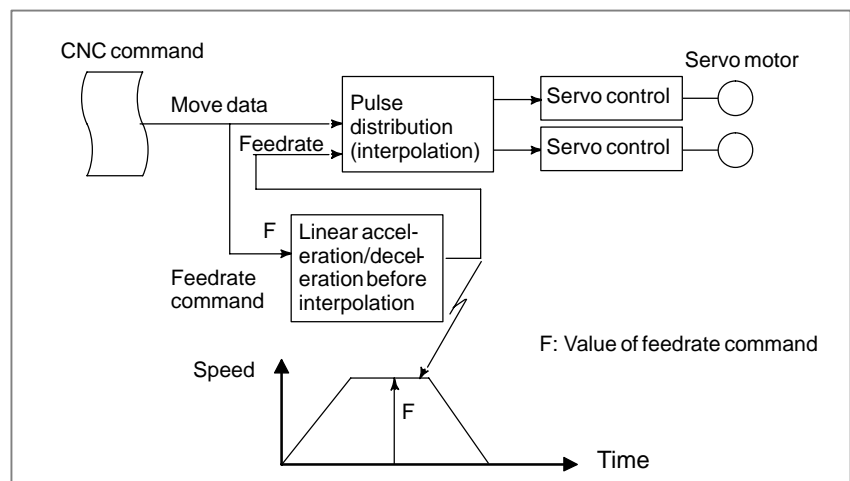

The function of linear acceleration/deceleration before interpolation increases or decreases the feedrate specified in the tangential direction.

If the feedrate command is changed

- Type A

Acceleration/deceleration is started in the block in which a new feedrate command is specified.

- Type B (Set the FWB bit (bit 0 of parameter No. 1602) to 1.)

Deceleration: Deceleration is started in a prior block such that deceleration is completed before the beginning of the block in which a new feedrate command is specified.

Acceleration: Acceleration is started in the block in which a new feedrate command is specified.

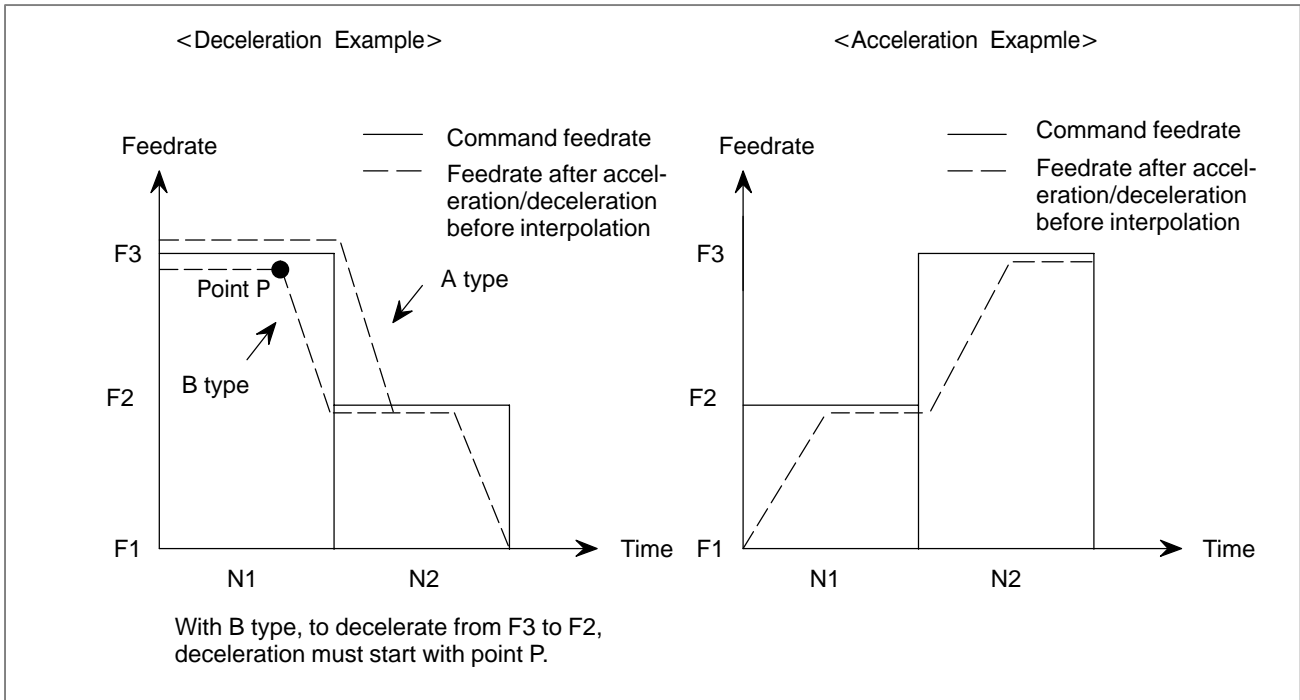

If an overtravel alarm occurs during linear acceleration/deceleration before interpolation, the movement is decelerated and stopped. As deceleration and stop are performed after the alarm occurs, the tool will overrun by an amount equal to the distance required for the deceleration. The actual overrun depends on the feedrate when the overtravel alarm occurs.

The distance can be minimized by starting deceleration in advance, such that the feedrate has fallen to the value specified in parameter No. 1784 when an overtravel alarm occurs. Because deceleration is executed such that the feedrate at the time an overtravel alarm occurs does not exceed the feedrate specified in the corresponding parameter, deceleration may be completed earlier. After deceleration is completed, the feedrate specified in the parameter is maintained.

Deceleration is performed when the following condition is satisfied:

$$\boxed{\text{Distance to stored stroke limit 1 for each axis}} < \boxed{\text{Distance needed to reduce the current feedrate (tangential feedrate) to that specified in parameter No. 1784}}$$

The overrun is calculated as follows:

$$\text{Overrun} \cong \frac{[\text{FIX} (\frac{F_{OT}}{F} \times \frac{T}{8}) + 1.5]^2 \times \frac{F}{T}}{1875}$$

F : Maximum cutting feedrate in linear acceleration/deceleration before interpolation (parameter No. 1630)

T : Time needed to attain the maximum cutting feedrate in linear acceleration/deceleration before interpolation (parameter No. 1631)

F_{OT}: Feedrate at the time an overtravel alarm occurs during linear acceleration/deceleration before interpolation (parameter No. 1784)

FIX: Any fractional part is truncated.

Parameter

	#7	#6	#5	#4	#3	#2	#1	#0
1602								FWB

[Data type] Bit

FWB Linear acceleration/deceleration of cutting feed before interpolation

0 : Type A of acceleration/deceleration before interpolation is used.

1 : Type B of acceleration/deceleration before interpolation is used.

1630	Parameter 1 for setting an acceleration for linear acceleration/deceleration before interpolation (maximum machining feedrate during linear acceleration/deceleration before interpolation)
------	---

[Data type] Two-word

[Unit of data]	Increment system	Unit of data	Valid data range	
			IS-A, IS-B	IS-C
[Valid data range]	Millimeter machine	1 mm/min	6 – 240000	6 – 100000
	Inch machine	0.1 inch/min	6 – 96000	6 – 48000

This parameter is used to set an acceleration for linear acceleration/deceleration before interpolation. In this parameter, set a maximum machining feedrate during linear acceleration/deceleration before interpolation. In parameter No. 1631, set a time used to reach the maximum machining feedrate.

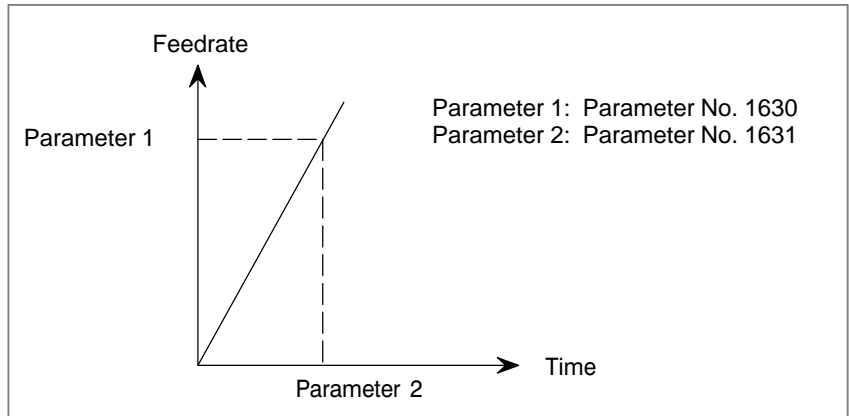

NOTE

- 1 When 0 is set in parameter No. 1630 or parameter No. 1631, linear acceleration/deceleration before interpolation is disabled.
- 2 In the advanced preview control mode, parameter No. 1770 and parameter No. 1771 are valid.

1631

Parameter2 for setting an acceleration for linear acceleration/deceleration before interpolation (time used to reach the maximum machining feedrate during linear acceleration/deceleration before interpolation.)

[Data type] Word

[Unit of data] 1 ms

[Valid data range] 0 to 4000

This parameter is used to set an acceleration for linear acceleration/deceleration before interpolation. In this parameter, set the time (time constant) used to reach the feedrate set in parameter No. 1630.

NOTE

- 1 When 0 is set in parameter No. 1630 or parameter No. 1631, linear acceleration/deceleration before interpolation is disabled.
- 2 In parameter Nos. 1630 and 1631, set values that satisfy the following:

$$\frac{\text{Parameter No. 1630}}{\text{Parameter No. 1631}} \cong 5$$

- 3 In the advanced preview control mode, parameter No. 1770 and parameter No. 1771 are valid.

1784

Feedrate when overtravel alarm has generated during
acceleration/deceleration before interpolation**[Data type]** Word**[Unit of data]****[Valid data range]**

Increment system	Unit of data	Valid data range	
		IS-A, IS-B	IS-C
Millimeter machine	1 mm/min	6 – 15000	6 – 12000
Inch machine	0.1 inch/min	6 – 6000	6 – 4800

Deceleration is started beforehand to reach the feedrate set in the parameter when an overtravel alarm is issued (when a limit is reached) during linear acceleration/deceleration before interpolation. By using this parameter, the overrun distance that occurs when an overtravel alarm is output can be reduced.

WARNING

The control described above is applicable only to stored stroke limit 1.

NOTE

- 1 When 0 is set in this parameter, the control described above is not exercised.
- 2 Use type-B linear acceleration/deceleration before interpolation (by setting bit 0 (FWB) of parameter No. 1602 to 1).

Note

NOTE

- 1 If a block without a move command is found during acceleration/deceleration before interpolation, the movement is decelerated and temporarily stopped in the previous block.
- 2 If a one-shot G code is specified during acceleration/deceleration before interpolation, the movement is decelerated and temporarily stopped in the previous block.
- 3 If an M, S, or T code is specified in a block containing a move command during acceleration/deceleration before interpolation, the movement is decelerated and temporarily stopped in that block.
- 4 During acceleration/deceleration before interpolation, a G31 block (skip function) is not subjected to acceleration/deceleration.
- 5 If the machine lock signal (MLK1 to MLK8) for an axis is set on or off during acceleration/deceleration before interpolation, the axis for which machine lock is performed is not subjected to acceleration/deceleration.
- 6 During acceleration/deceleration before interpolation, automatic corner override is enabled only when the internal circular cutting feedrate is changed.
- 7 During acceleration/deceleration before interpolation, acceleration/deceleration after interpolation can be executed. So that acceleration/deceleration is executed only before interpolation, set the time constant for acceleration/deceleration after interpolation to zero.
- 8 In acceleration/deceleration before interpolation of type B, deceleration is started if preprocessing for the next block has not been completed before the remaining distance of the current block becomes less than that needed to decelerate and stop the movement.
- 9 If an F1-digit command is executed in the inch input system, avoid specifying a command for simultaneous movement on two axes, including a rotation axis during acceleration/deceleration before interpolation (M series).
- 10 The error detect signal (SMZ) is invalid during acceleration/deceleration before interpolation (T series).
- 11 If an overtravel alarm occurs during acceleration/deceleration before interpolation, the movement is decelerated and stopped. As deceleration and stop are performed after the alarm occurs, the tool will overrun by the distance required for the deceleration.
- 12 When feed per revolution is specified during acceleration/deceleration before interpolation, the spindle speed can be set to up to 30000 min^{-1} in theory.
- 13 If switching between feed per revolution and feed per minute is performed at the interface of two blocks during acceleration/deceleration before interpolation, the movement is decelerated and temporarily stopped in the previous block.

7.2.6 Corner Control

7.2.6.1 In-position check

General

Whether the position of the servo motor is within a specified range is checked.

If the in-position check function is enabled, the CNC checks the position during deceleration. If the position is found to exceed the specified range, the CNC does not execute the next block.

NOTE

The purpose of in-position check is to check that the servo motor has reached within a specified range (specified with parameter No. 1826).

Signal

In-position signals INP1 to INP8 <F104>

[Classification] Output signal

[Function] These signals indicate that the control axes are set to the in-position condition. They are provided for each control axis, and the number in the signal name corresponds to the control axis number.

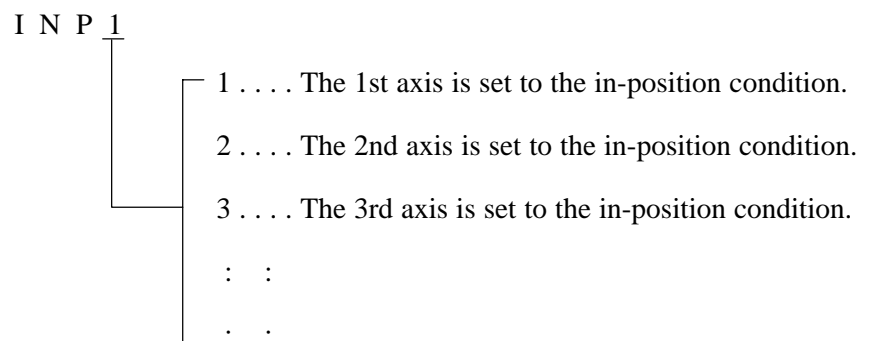

[Output condition] These signals turn to “1” in the following case :

- The servo error of the corresponding control axis is within the specified allowance.

These signals turn to “0” in the following cases :

- The servo error of the corresponding control axis exceeds the specified allowance

Signal address

	#7	#6	#5	#4	#3	#2	#1	#0
F104	INP8	INP7	INP6	INP5	INP4	INP3	INP2	INP1

Parameter

	#7	#6	#5	#4	#3	#2	#1	#0
1601			NCI					

[Data type] Bit

NCI Inposition check at deceleration

0 : Performed

1 : Not performed

1826	In-position width for each axis
------	---------------------------------

[Data type] Word axis

[Unit of data] Detection unit

[Valid data range] 0 to 32767

The in-position width is set for each axis.

When the deviation of the machine position from the specified position (the absolute value of the positioning deviation) is smaller than the in-position width, the machine is assumed to have reached the specified position.

Note

NOTE

- 1 The in-position signals may turn to "1" even during the movement if the axis is fed at very low speed.
- 2 The in-position check function is enabled, at the interface between two cutting blocks, in the following cases:

M series	When the exact stop command (G09) or exact stop mode command (G61) is specified
T series	When the error detect signal is on

**7.2.6.2
In-position check
independently of
feed/rapid traverse**

General

If separate in-position check for cutting feed and rapid traverse is executed, a small in-position check range can be specified between those cutting feed blocks that require a high degree of precision. A large in-position check range can be specified between those rapid traverse blocks that require quick positioning.

Signal

See Subsection 7.2.6.1.

Parameter

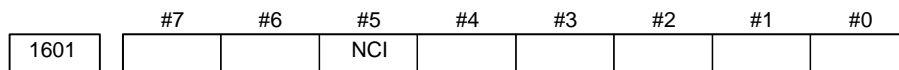

[Data type] Bit

NCI Inposition check at deceleration
 0 : Performed
 1 : Not performed

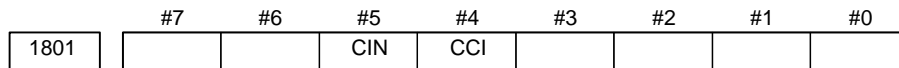

[Data type] Bit

CCI The in-position area for cutting feed is:
 0 : Set in parameter No. 1826 (same as for rapid traverse).
 1 : Set in bit 5 (CIN) of parameter No. 1801.

CIN When bit 4 (CCI) of parameter No. 1801 = 1, the in-position area for cutting feed is:
 0 : Use value in parameter No. 1827 if the next block is also for cutting feed, or use value in parameter No. 1826 if the next block is for rapid traverse.
 1 : Use value in parameter No. 1827, regardless of the next block. (The setting of parameter No. 1826 is used for rapid traverse, and the setting of parameter No. 1827 is used for cutting feed.)

		Parameter CIN (No. 1801#5)			
		0		1	
Parameter CCI (No. 1801#4)	0	Rapid→Rapid Rapid→Feed Feed→Feed Feed→Rapid	No. 1826 No. 1826 No. 1826 No. 1826	Rapid→Rapid Rapid→Feed Feed→Feed Feed→Rapid	No. 1826 No. 1826 No. 1826 No. 1826
	1	Rapid→Rapid Rapid→Feed Feed→Feed Feed→Rapid	No. 1826 No. 1826 No. 1827 No. 1826	Rapid→Rapid Rapid→Feed Feed→Feed Feed→Rapid	No. 1826 No. 1826 No. 1827 No. 1827

1826	In-position width for each axis
------	---------------------------------

[Data type] Word axis

[Unit of data] Detection unit

[Valid data range] 0 to 32767

The in-position width is set for each axis.

When the deviation of the machine position from the specified position (the absolute value of the positioning deviation) is smaller than the in-position width, the machine is assumed to have reached the specified position.

1827	In-position width in cutting feed for each axis
------	---

[Data type] Word

[Unit of data] Detection unit

[Valid data range] 0 to 32767

Set an in-position width for each axis in cutting feed. This parameter is valid when bit 4 (CCI) of parameter No. 1801=1.

Note

NOTE

If the NCI bit (bit 5 of parameter No. 1601) is set to 1, so that position check is not performed during deceleration, this function is invalid. The system starts execution of the next block as soon as deceleration has been completed, without checking whether the servo position error is within the specified range.

7.2.6.3 Error detect (T series)

General

Generally, the CNC does not zero the feedrate at the interface of two blocks during cutting feed. Because of this, a corner of a tool path may be rounded.

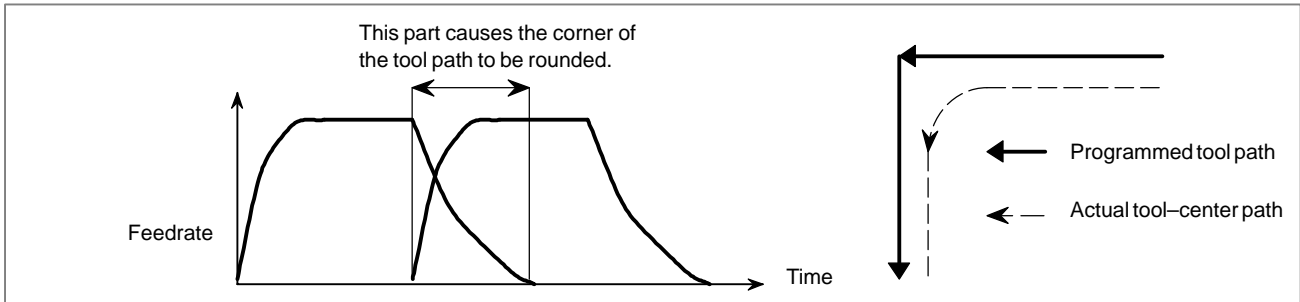

If the error detect signal is used, it is possible to specify that a block not be started until the acceleration/deceleration of the previous block has been completed.

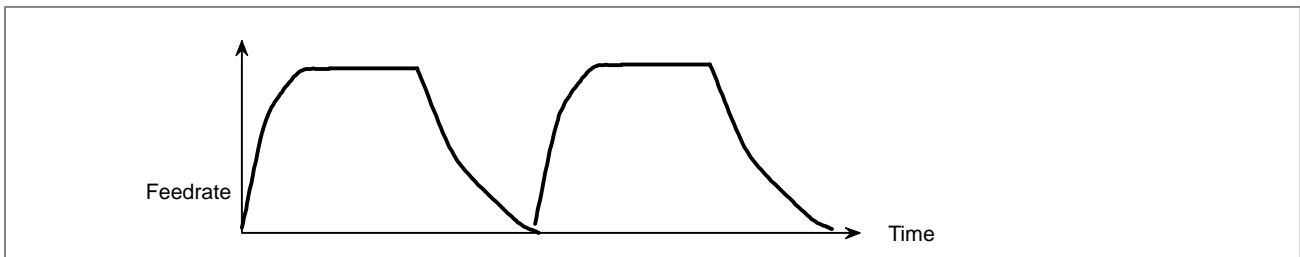

Signal

Error detect signal SMZ <G053, #6>

[Classification] Input signal

[Function] Enables error detection.

[Operation] If the signal is set to 1, the control unit operates as follows:

- At the interface of two blocks during cutting feed, the control unit waits until the acceleration/deceleration of the first block has been completed. Only then does the control unit execute the next block. The setting of the SMZ signal determines whether, at the interface of two cutting blocks, the control unit waits until the acceleration/deceleration of the previous block has been completed.

Signal address

	#7	#6	#5	#4	#3	#2	#1	#0
G053		SMZ						

Note

NOTE

If the error detect signal is on, a cutting block is not executed until the acceleration/deceleration of the previous cutting block has been completed.

This function alone cannot prevent corner rounding due to delay caused by the servo motor, however.

To prevent corner rounding due to delay caused by the servo motor, use the in-position check function together with this function.

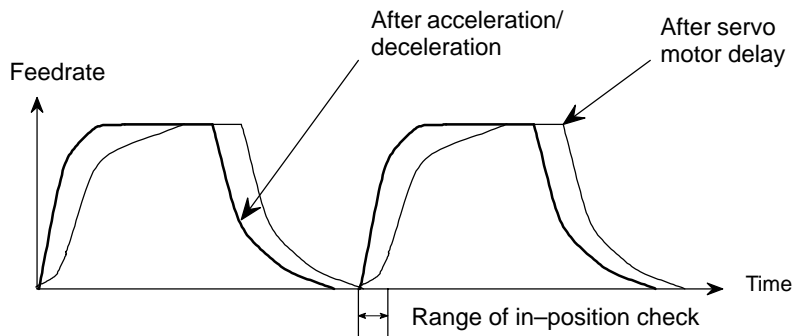

**7.2.7
Feed Forward in Rapid
Traverse**

General

Feed-forward control can be performed even during rapid traverse. In this case, the servo position error is reduced, thus reducing the time required for positioning to within the specified range.

Parameter

	#7	#6	#5	#4	#3	#2	#1	#0
1800					FFR			

[Data type] Bit

FFR Feed-forward control is enabled for

0 : Cutting feed only

1 : Cutting feed and rapid traverse

Reference item

For details of this function, refer to the “FANUC SERVO MOTOR α series Maintenance Manual (B-65165E)” or “FANUC SERVO MOTOR αi series Maintenance Manual (B-65285EN).”

8

AUXILIARY FUNCTION



8.1 MISCELLANEOUS FUNCTION/2ND AUXILIARY FUNCTION

General

- **Miscellaneous Function (M code)**

When an M code address is programmed, a code signal and a strobe signal are sent to the machine. The machine uses these signals to turn on or off its functions.

Usually, only one M code can be specified in one block. In some cases, however, up to three M codes can be specified for some types of machine tools (see 8.3 “Multiple M code per Block”)

Also, parameter No. 3030 can specify the maximum digits and if a specified value exceeds the maximum digits, an alarm may be issued.

- **2nd Auxiliary Function (B code)**

When up to eight digits are specified after address B, a code signal and strobe signal are sent. These signals are used to index the rotation axis of the machine. The code signal is retained until another B code is specified.

In each block, a single B code can be specified. The maximum number of digits that can be specified after address B is specified in parameter No. 3033. If more digits than the specified value are specified, an alarm occurs.

For the M series, the address for specifying the 2nd auxiliary function can be changed from B to another address (A, C, U, V, or W) by parameter setting (parameter No. 3460).

- **Command Format of 2nd Auxiliary Function**

- **Command range** -99999999 to +99999999

- **Command method**
 1. For the M series, a decimal point and a negative value can be used for input by setting AUP (bit 0 of parameter No. 3450).
With the T series, a decimal point and a negative value are always enabled regardless of the parameter setting.

Command	Output value
B10.	10000
B10	10

2. It is possible to change over the scale factor of B output, 1000 or 1 when the decimal point input is omitted, using the parameter DPI (No.3401#0).

Command	Output value
When DPI is 1: B1	1000
When DPI is 0: B1	1

3. It is possible to change over the scale factor of B output 1000 or 10000 when the decimal point input is omitted in the inch input system, using the parameter AUX (No.3405#0). When DPI=1.

Command	Output value
When AUX is 1: B1	10000
When AUX is 0: B1	1000

Basic procedure

The following signals are used with these functions. (For details of the spindle-speed function and tool function, see Chapters 9 and 10.)

Function	Program address	Output signal			Input signal
		Code signal	Strobe signal	Distribution end signal	Completion signal
Miscellaneous function	M	M00 to M31	MF	DEN	FIN
Spindle-speed function	S	S00 to S31	SF		
Tool function	T	T00 to T31	TF		
Secondary auxiliary function	B	B00 to B31	BF		

Each function uses different program addresses and different signals, but they all input and output signals in the same way, as described below. (A sample procedure for the miscellaneous function is described below. The procedures for the spindle-speed function, tool function, and secondary auxiliary function, are obtained simply by substituting S, T, or B in place of M.)

- (1) Suppose that Mxxx is specified in a program.

For xxx, the number of specifiable digits is specified in parameter Nos. 3030 to 3033 for each function. If more digits than the specified value are specified, an alarm occurs.

- (2) Code signal M00 to M31 is sent to machine interface. After period TMF, specified in parameter No. 3010 (standard value: 16 msec), the strobe signal MF is set to 1. The code signal is the binary representation of the programmed value xxx.(*1) If a move, dwell, spindle-speed, or other function is specified in the same block as the miscellaneous function, the execution of the other function is started when the code signal of the miscellaneous function is sent.
- (3) When the strobe signal is set to 1, the PMC reads the code signal and performs the corresponding operation.
- (4) To execute an operation after the completion of the move, dwell or other function specified in the block, wait until distribution end signal DEN is set to 1.
- (5) Upon completion of the operation, the PMC sets completion signal FIN to 1. The completion signal is used by the miscellaneous function, spindle-speed function, tool function, secondary auxiliary function, external operation function described later, and other functions. If any of these functions are executed simultaneously, the completion signal must be set to 1 upon completion of all the functions.

(6) If the completion signal remains set to 1 for longer than period TFIN, specified in parameter No. 3011 (standard value: 16 msec), the CNC sets the strobe signal to 0 and reports that the completion signal has been received.

(7) When the strobe signal is set to 0, set the completion signal to 0 in the PMC.

(8) When the completion signal is set to 0, the CNC sets all code signals to 0 and completes all sequences of the miscellaneous function. (*2)

(9) Once all other commands in the same block have been completed, the CNC executes the next block.

*1 When the tool function is executed, the programmed tool number is sent as the code signal (T series).

*2 When the spindle-speed function, tool function, or secondary auxiliary function is executed, the code signal is maintained until a new code for the corresponding function is specified.

The timing diagram is shown below:

Example 1 Single miscellaneous function specified in a block

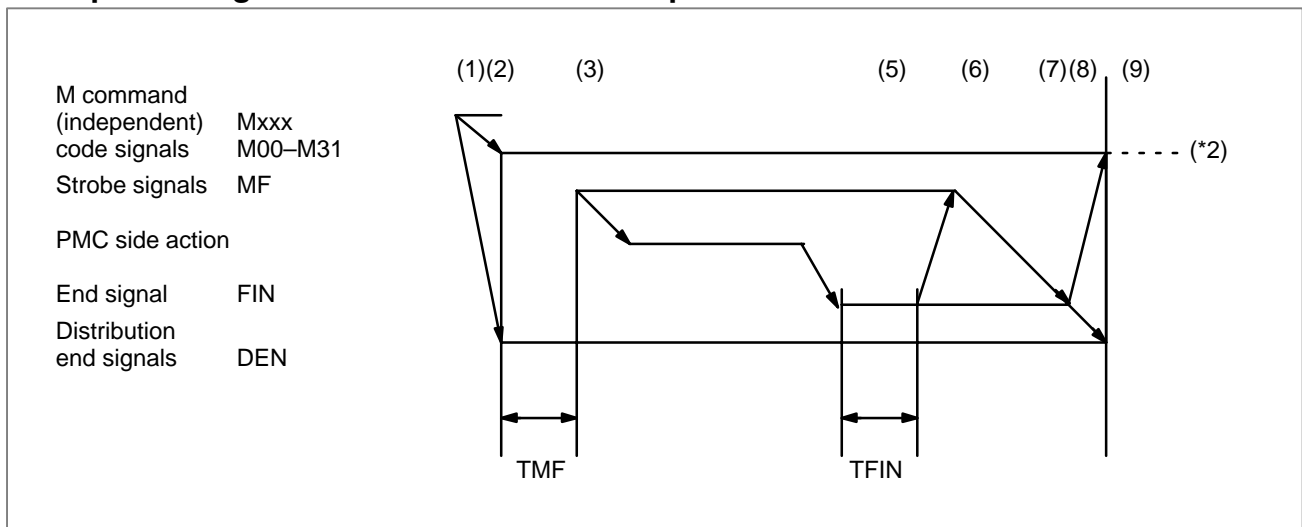

Example 2 Move command and miscellaneous function in the same block

2a. Execution of a miscellaneous function without waiting for move command completion

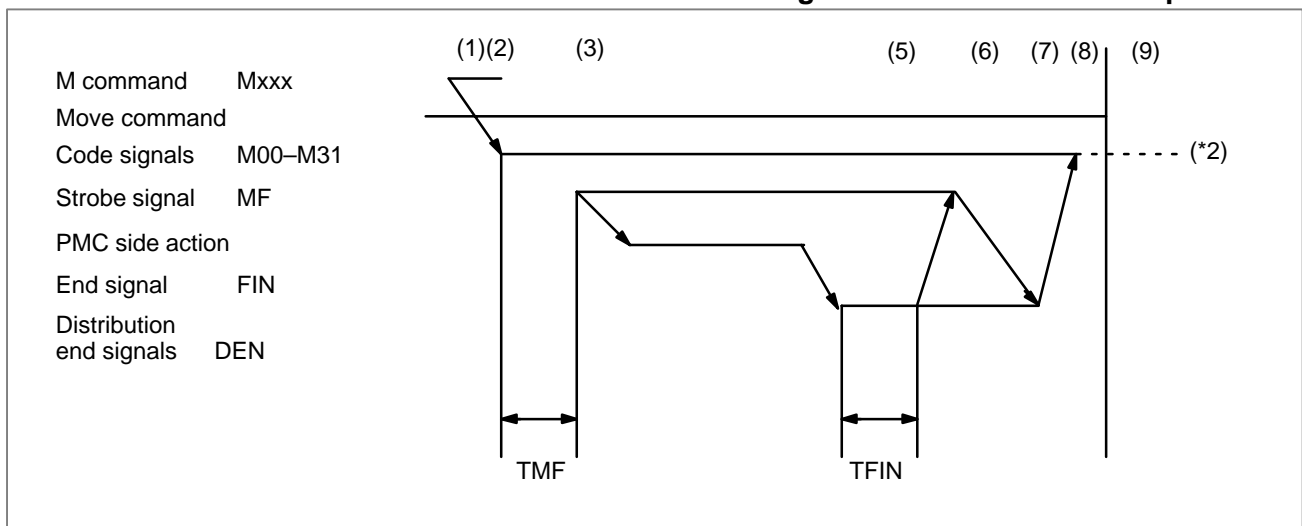

2b. Execution of a miscellaneous function after move command completion

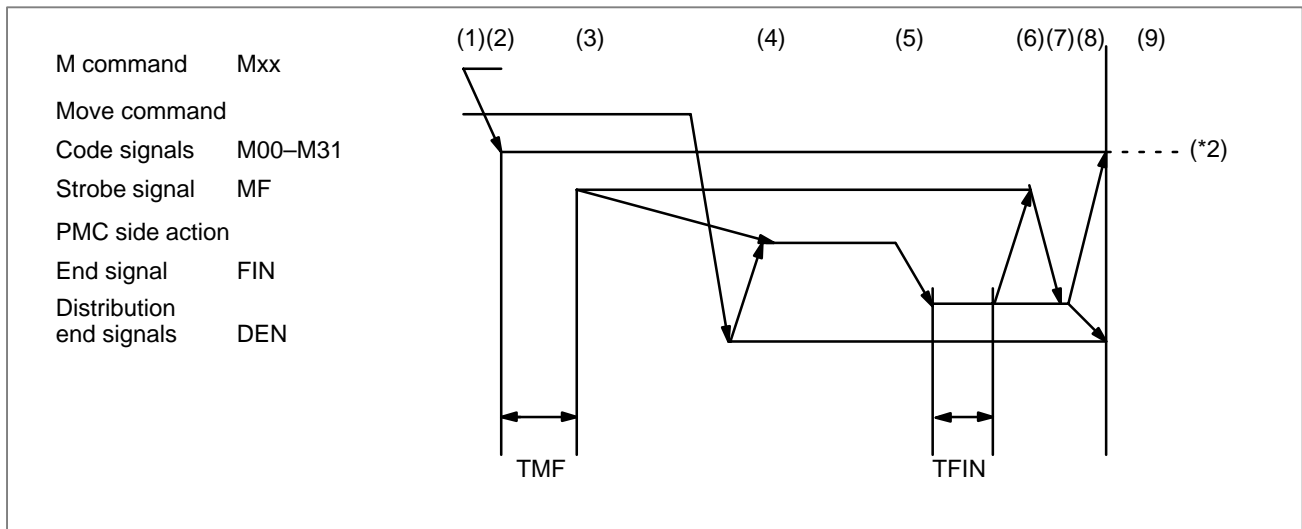

Signal

Miscellaneous function code signals

M00 to M31 <F010 to F013>

Miscellaneous function strobe signal

MF <F007#0> [Classification] Output signal

[Function] These signals report the specification of miscellaneous functions.

[Output condition] For the output conditions and procedure, see the description of “Basic procedure” above.

NOTE

- 1 The following miscellaneous functions are only processed internally by the control unit; they are not output to the PMC when programmed:
 - M98, M99, M198
 - M code that calls a sub program (parameter No. 6071 to 6079)
 - M code that calls a custom macro (parameter No. 6080 to 6089)
- 2 Decode signals as well as the code signals and strobe signal are output for the miscellaneous functions listed below.
M00, M01, M02, M30

Decode M signals**DM00 <F009#7>**,**DM01 <F009#6>**,**DM02 <F009#5>**,**DM30 <F009#4>****[Classification]** Output signal**[Function]** These signals report particular miscellaneous functions are specified. The miscellaneous functions in a command program correspond to output signals as indicated below.

Command program	Output signal
M00	DM00
M01	DM01
M02	DM02
M30	DM30

[Output condition] A decode M signal goes “1” when:

- The corresponding miscellaneous function is specified, and any move commands and dwell commands specified in the same block are completed. These signals are not output when the end signal of the miscellaneous function is returned before completion of such move commands and dwell commands.

A decode M signal goes “0” when:

- The FIN signal goes “1”
- Reset occurs

Spindle-speed code**signals S00 to S31****<F022-F025>****Spindle-speed strobe****signal SF <F007#2>****[Classification]** Output signal**[Function]** These signals report that spindle speed functions have been specified.**[Output condition]** For the output conditions and procedure, see the description of “Basic procedure” above.**Tool function code****signals T00 to T31****<F026-F029>****Tool function strobe****signal TF <F007#3>****[Classification]** Output signal**[Function]** These signals report that tool functions have been specified.**[Output condition]** For the output conditions and procedure, see the description of “Basic procedure” above.

**Second auxiliary
function code signals
B00 to B31
<F030–F033>
Second auxiliary
function strobe signal
BF <F007#4> (T series)
<F007#7> (M series)**

[Classification] Output signal

[Function] These signals report that second auxiliary functions have been specified.

[Output condition] For the output conditions and procedure, see the description of “Basic procedure” above.

End signal FIN <G004#3>

[Classification] Input signal

[Function] This signal reports the completion of a miscellaneous function, spindle-speed function, tool function, second auxiliary function, or external operation function.

[Operation] For the control unit operation and procedure when this signal goes “1”, see the description of “Basic procedure” above. The FIN signal must remain “1” for a certain time (TFIN, which is set by a parameter No. 3011) or longer. The FIN signal driven “1” is ignored if the FIN signal goes “0” before TFIN elapses.

WARNING

Only one end signal is used for all functions above. The end signal must go “1” after all functions are completed.

**Distribution end signal
DEN <F001#3>**

[Classification] Output signal

[Function] These signals report that all commands (such as move commands and dwell) are completed except those miscellaneous functions, spindle-speed functions, 2nd auxiliary functions tool functions, and so forth that are contained in the same block and have been sent to the PMC. They also report that the end signal from the PMC is being awaited.

[Output condition] The DEN signal turns to “1” when:

- Waiting for the completion of miscellaneous functions, spindle-speed functions, tool functions, 2nd auxiliary functions and all other commands in the same block are completed, and the current position is in the in-position.

The DEN signal turns to “0” when:

- The execution of one block is completed

NOTE

A parameter NCI (No.1601#5) can specify, whether to only check if an acceleration/deceleration delay is eliminated, or to also check if a servo delay (error) has been reduced to within a certain range.

Signal address

	#7	#6	#5	#4	#3	#2	#1	#0
G004					FIN			
	#7	#6	#5	#4	#3	#2	#1	#0
F001					DEN			
F007	BF			BF	TF	SF		MF
F009	DM00	DM01	DM02	DM30				
F010	M07	M06	M05	M04	M03	M02	M01	M00
F011	M15	M14	M13	M12	M11	M10	M09	M08
F012	M23	M22	M21	M20	M19	M18	M17	M16
F013	M31	M30	M29	M28	M27	M26	M25	M24
F022	S07	S06	S05	S04	S03	S02	S01	S00
F023	S15	S14	S13	S12	S11	S10	S09	S08
F024	S23	S22	S21	S20	S19	S18	S17	S16
F025	S31	S30	S29	S28	S27	S26	S25	S24
F026	T07	T06	T05	T04	T03	T02	T01	T00
F027	T15	T14	T13	T12	T11	T10	T09	T08
F028	T23	T22	T21	T20	T19	T18	T17	T16
F029	T31	T30	T29	T28	T27	T26	T25	T24
F030	B07	B06	B05	B04	B03	B02	B01	B00
F031	B15	B14	B13	B12	B11	B10	B09	B08
F032	B23	B22	B21	B20	B19	B18	B17	B16
F033	B31	B30	B29	B28	B27	B26	B25	B24

Parameter

3010 Time lag in strobe signals MF, SF, TF, and BF

[Data type] Word

[Unit of data] 1 ms

[Valid data range] 16 to 32767

The time required to send strobe signals MF, SF, TF, and BF after the M, S, T, and B codes are sent, respectively.

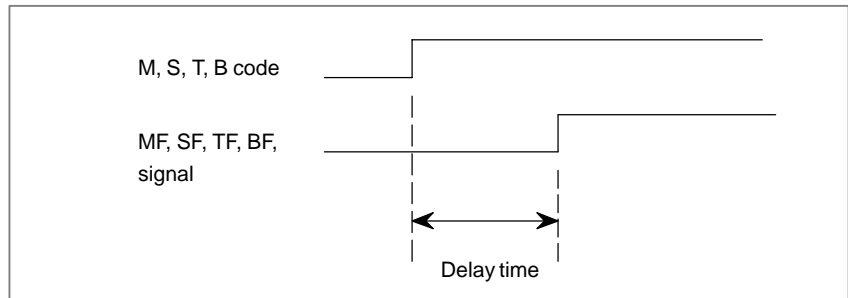

Fig. 8.1 (a) Delay time of the strobe signal

NOTE

The time is counted in units of 8 ms. If the set value is not a multiple of eight, it is raised to the next multiple of eight.

Example : When 30 is set, 32 ms is assumed.
 When 32 is set, 32 ms is assumed.
 When 100 is set, 104 ms is assumed.

3011 Acceptable width of M, S, T, and B function completion signal (FIN)

[Data type] Word

[Unit of data] 1 ms

[Valid data range] 16 to 32767

Set the minimum signal width of the valid M, S, T, and B function completion signal (FIN).

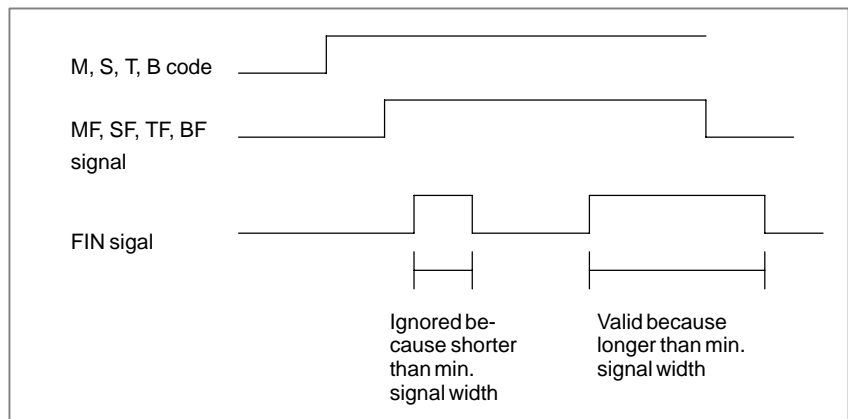

Fig. 8.1 (b) Valid Width of the FIN (M,S, T, and B Function Completion) Signal

NOTE

The time is counted in units of 8 ms. If the set value is not a multiple of eight, it is raised to the next multiple of eight.

Example: When 30 is set, 32 ms is assumed.

3030	Allowable number of digits for the M code
3031	Allowable number of digits for the S code
3032	Allowable number of digits for the T code
3033	Allowable number of digits for the B code

[Data type] Byte

[Valid data range] 1 to 8

Set the allowable numbers of digits for the M, S, T, and B codes.

NOTE

Up to 5 digits can be specified in the S code

	#7	#6	#5	#4	#3	#2	#1	#0
3401								DPI

[Data type] Bit

DPI When a decimal point is omitted in an address that can include a decimal point

0 : The least input increment is assumed.

1 : The unit of mm, inches, or second is assumed. (Pocket calculator type decimal point input)

	#7	#6	#5	#4	#3	#2	#1	#0
3404			M02	M30				

[Data type] Bit

M30 When M30 is specified in a memory operation:

0 : M30 is sent to the machine, and the head of the program is automatically searched for. So, when the end signal FIN is returned and a reset or reset and rewind operation is not performed, the program will still be executed, starting from the beginning of the program.

1 : M30 is sent to the machine, but the head of the program is not searched for. (The head of the program is searched for by the reset and rewind signal.)

M02 When M02 is specified in memory operation

0 : M02 is sent to the machine, and the head of the program is automatically searched for. So, when the end signal FIN is returned and a reset or reset and rewind operation is not performed, the program will still be executed, starting from the beginning of the program.

1 : M02 is sent to the machine, but the head of the program is not searched for. (The head of the program is searched for by the reset and rewind signal.)

	#7	#6	#5	#4	#3	#2	#1	#0
3405								AUX

[Data type] Bit

AUX The least increment of the command of the second miscellaneous function specified with a decimal point

0 : Assumed to be 0.001

1 : Depending on the input increment. (For input in mm, 0.001 is assumed, or for input in inches, 0.0001 is assumed.)

3411	M code preventing buffering 1
3412	M code preventing buffering 2
3413	M code preventing buffering 3
:	:
3420	M code preventing buffering 10

[Data type] Byte

[Valid data range] 0 to 255

Set M codes that prevent buffering the following blocks. If processing directed by an M code must be performed by the machine without buffering the following block, specify the M code.

M00, M01, M02, and M30 always prevent buffering even when they are not specified in these parameters.

3421	Minimum value 1 of M code preventing buffering
3422	Maximum value 1 of M code preventing buffering
3423	Minimum value 2 of M code preventing buffering
3424	Maximum value 2 of M code preventing buffering
3425	Minimum value 3 of M code preventing buffering
3426	Maximum value 3 of M code preventing buffering
3427	Minimum value 4 of M code preventing buffering
3428	Maximum value 4 of M code preventing buffering
3429	Minimum value 5 of M code preventing buffering
3430	Maximum value 5 of M code preventing buffering
3431	Minimum value 6 of M code preventing buffering
3432	Maximum value 6 of M code preventing buffering

[Data type] Word

[Valid data range] 0 to 65535

When a specified M code is within the range specified with parameter Nos. 3421 and 3422, 3433 and 3424, 3425 and 3426, 3427 and 3428, 3429 and 3430, or 3431 and 3432, buffering for the next block is not performed until the execution of the block is completed.

CAUTION

- 1 The specification of a minimum value that exceeds the specified maximum value is invalid.
- 2 When there is only one data item, set the following:
minimum value =maximum value.

3450	#7	#6	#5	#4	#3	#2	#1	#0
								AUP

AUP A second auxiliary function command, specified with a decimal point and a negative value is:

- 0 : Disabled.
- 1 : Enabled.

NOTE

With the T series, second auxiliary function commands specified with a decimal point and a negative value are always enabled regardless of the parameter setting.

3460	
	Name of a second auxiliary function

[Data type] Byte

Set the name of a second auxiliary function according to the table given below. Note that the same address as an axis name cannot be set.

Name	A	B	C	U	V	W
Setting	65	66	67	85	86	87

If a value other than those given above is set, address B is assumed.

Note**NOTE**

- 1 When a move command and miscellaneous function are specified in the same block, the commands are executed in one of the following two ways:
 - i) Simultaneous execution of the move command and miscellaneous function commands.
 - ii) Executing miscellaneous function commands upon completion of move command execution.
The selection of either sequence depends on the sequence of PMC.
- 2 When the 2nd auxiliary function is provided, the address used for specifying the 2nd auxiliary function (B or the address specified with parameter No. 3460) cannot be used as an axis address.
- 3 The block following M00, M01, M02 and M30, is not read into the input buffer register, if present. Similarly, ten M codes which do not buffer can be set by parameters (No. 3411 to 3420).
- 4 For M00 and M01 only, miscellaneous function code signal, auxiliary function strobe signal, and M decode signals are sent; the control of program stop and optional stop shall be designed on the PMC side.
- 5 When the automatic operation is stopped by M02 or M30, it is necessary to send the external reset signal from the machine side to the CNC, instead of the FIN signal, When the external reset signal is returned against the M02 or M30, the control returns to the top of the program recently executed and enters the reset state. When the FIN signal is returned, the control returns to the beginning of the program recently executed and executes it from the top.

Reference item

Series 16 <i>i</i> /18 <i>i</i> /160 <i>i</i> /180 <i>i</i> / 160 <i>s</i> /180 <i>s</i>	OPERATOR'S MANUAL (For Machining Center) (B-63534EN)	II.11.1	Miscellaneous function (M code)
		II.11.4	2nd Auxiliary function (B code)
	OPERATOR'S MANUAL (For Lathe) (B-63524EN)	II.11.1	Miscellaneous function (M code)
		II.11.4	2nd Auxiliary function (B code)
Series 21 <i>i</i> /210 <i>i</i> /210 <i>s</i>	OPERATOR'S MANUAL (For Machining Center) (B-63614EN)	II.11.1	Miscellaneous function (M code)
		II.11.3	2nd Auxiliary function (B code)
	OPERATOR'S MANUAL (For Lathe) (B-63604EN)	II.11.1	Miscellaneous function (M code)
		II.11.3	2nd Auxiliary function (B code)
Series 20 <i>i</i>	OPERATOR'S MANUAL (For Manual Milling Machine) (B-64204EN)	II.11.1	Miscellaneous function (M code)
	OPERATOR'S MANUAL (For Manual Lathes) (B-64194EN)	II.11.1	Miscellaneous function (M code)

8.2 AUXILIARY FUNCTION LOCK

General

Inhibits execution of a specified M, S, T and B function. That is, code signals and strobe signals are not issued. This function is used to check a program.

Signal

Auxiliary function lock signal AFL <G005#6>

[Classification] Input signal

[Function] This signal selects auxiliary function lock. That is, this signal disables the execution of specified M, S, T, and B functions.

[Operation] When this signal turns to “1”, the control unit functions as described below.

- (1) The control unit does not execute M, S, T, and B functions specified for memory operation, DNC operation, or MDI operation. That is, the control unit stops the output of code signals and strobe signals (MF, SF, TF, BF).
- (2) If this signal turns to “1” after code signal output, the output operation is executed in the ordinary manner until its completion (that is, until the FIN signal is received, and the strobe signal turns to “0”).
- (3) Among the miscellaneous functions, M00, M01, M02, and M30 are executed even when this signal is “1”. All code signals, strobe signals, decode signals are output in the ordinary manner.
- (4) Among the miscellaneous functions, even when this signal is “1”, those functions (M98 and M99) that are executed in the control unit without outputting their execution results are executed in the ordinary manner.

WARNING

Even when this signal is “1”, spindle analog output or spindle serial output is executed.

Auxiliary function lock check signal MAFL <F004#4>

[Classification] Output signal

[Function] This signal reports the state of the auxiliary function lock signal AFL.

[Output condition] This signal turns to “1” when:

- The auxiliary function lock signal AFL is “1”

This signal turns to “0” when:

- The auxiliary function lock signal AFL is “0”

Signal address

	#7	#6	#5	#4	#3	#2	#1	#0
G005		AFL						
F004				MAFL				

Reference item

Series 16i/18i/160i/180i/ 160is/180is	OPERATOR'S MANUAL (For Machining Center) (B-63534EN)	III.5.1	Machine lock and auxiliary func- tion lock
	OPERATOR'S MANUAL (For Lathe) (B-63524EN)	III.5.1	Machine lock and auxiliary func- tion lock
Series 21i/210i/210is	OPERATOR'S MANUAL (For Machining Center) (B-63614EN)	III.5.1	Machine lock and auxiliary func- tion lock
	OPERATOR'S MANUAL (For Lathe) (B-63604EN)	III.5.1	Machine lock and auxiliary func- tion lock
Series 20i	OPERATOR'S MANUAL (For Manual Milling Machine) (B-64204EN)	III.5.1	Machine lock and auxiliary func- tion lock
	OPERATOR'S MANUAL (For Manual Lathes) (B-64194EN)	III.5.1	Machine lock and auxiliary func- tion lock

8.3 MULTIPLE M COMMANDS IN A SINGLE BLOCK

General

So far, one block has been able to contain only one M code. However, this function allows up to three M codes to be contained in one block.

Up to three M codes specified in a block are simultaneously output to the machine. This means that compared with the conventional method of a single M command in a single block, a shorter cycle time can be realized in machining.

(Example)

One M command in a single block	Multiple M commands in a single block
M40 ;	M40M50M60 ;
M50 ;	G28G91X0Y0Z0 ;
M60 ;	:
G28G91X0Y0Z0 ;	:
:	:
:	:
:	:

Basic procedure

- (1) Assume that "MaaMbbMcc;" was commanded by the program.
- (2) The 1st M command (Maa) sends the code signals M00 to M31 in a manner similar to the conventional one-block single command. The strobe signal MF is set to "1" after a time TMF set by parameter No. 3010 (Standard setting: 16 msec).
The second M command (Mbb) sends the code signal M200-M215, the third M command (Mcc) sends the code signal M300-M315, and their respective strobe signals MF2 and MF3 are set to "1".
Furthermore, the three code signals are sent simultaneously.
The strobe signals MF, MF2, and MF3 become "1" at the same time.
The code signal is a binary notation of the program command aa, bb and cc.
- (3) On the PMC side, the code signals corresponding to the respective strobe signals are read when the strobe signals become "1", and the appropriate operations are performed.
- (4) When the operation of all M commands ends on the PMC side, the end signal (FIN) is set to "1".
- (5) When the completion signal stays "1" for a time (TFIN) set by parameter No. 3011 (Standard: 16 msec), all strobe signals (MF, MF2 and MF3) are set to "0" at the same time and the reception of completion signal is reported.
- (6) On the PMC side, when MF, MF2 and MF3 are set to "0", the completion signal is set to "0".

A time chart for this procedure is shown below:

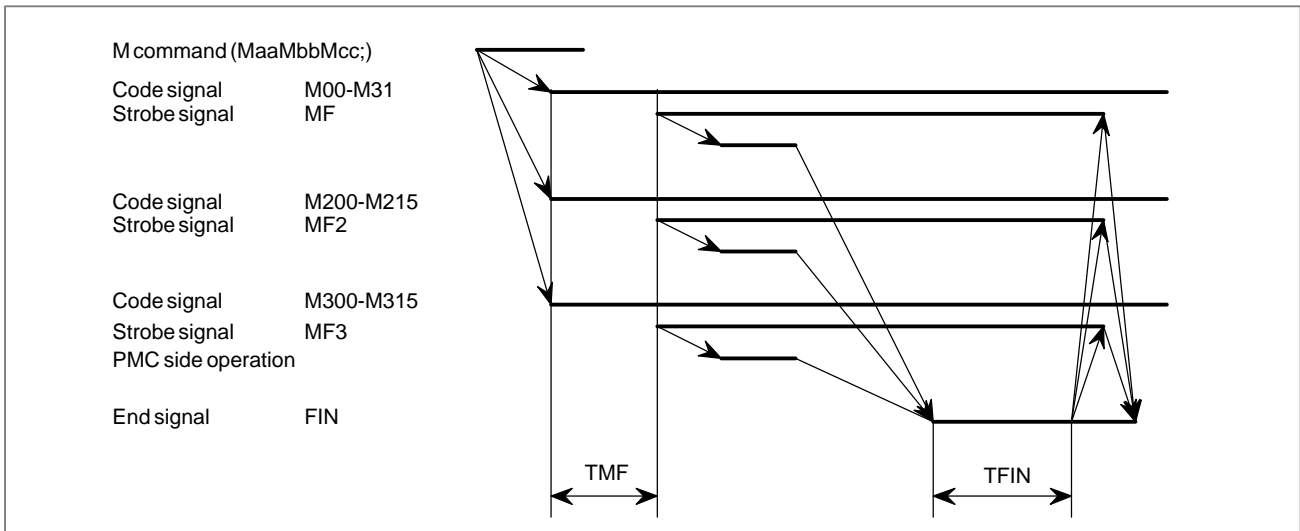

Signal

**2nd, 3rd M function code
signal M200 to M215
<F014, F015>
M300 to M315 <F016,
F017>
2nd, 3rd M Function
strobe signal MF2
<F008#4>
MF3 <F008#5>**

[Classification] Output signal

[Function] Indicates that second and third auxiliary functions have been issued.

[Output condition] The output conditions and procedures are the same as that described in “Basic procedure”.

Signal address

	#7	#6	#5	#4	#3	#2	#1	#0
F008			MF3	MF2				
F014	M207	M206	M205	M204	M203	M202	M201	M200
F015	M215	M214	M213	M212	M211	M210	M209	M208
F016	M307	M306	M305	M304	M303	M302	M301	M300
F017	M315	M314	M313	M312	M311	M310	M309	M308

Parameter

	#7	#6	#5	#4	#3	#2	#1	#0
3404	M3B							

[Data type] Bit

M3B The number of M codes that can be specified in one block

0 : One

1 : Up to three

Caution**CAUTION**

- 1 M00, M01, M02, M30, M98, M99, or M198 must not be specified together with another M code.
- 2 Some M codes other than M00, M01, M02, M30, M98, M99, and M198 cannot be specified together with other M codes; each of those M codes must be specified in a single block. Such M codes include these which direct the CNC to perform internal operations in addition to sending the M codes themselves to the PMC. To be specified, such M codes are M codes for calling program numbers 9001 to 9009 and M codes for disabling advance reading (buffering) of subsequent blocks.

The M codes which can be specified in a single block must be those which the CNC sends the M code signals to the PMC side.

Note**NOTE**

- 1 CNC allows up to three M codes to be specified in one block. However, some M codes cannot be specified at the same time due to mechanical operation restrictions. For example, M42 can be specified only after the mechanical operation of M41 is completed.
- 2 The 1st M code can be up to 8 digits and 2nd, 3rd M codes can be the values up to 65535.

Reference item

Series 16i/18i/160i/180i/ 160is/180is	OPERATOR'S MANUAL (For Machining Center) (B-63534EN)	II.11.2	Multiple M commands in a single block
	OPERATOR'S MANUAL (For Lathe) (B-63524EN)	II.11.2	Multiple M commands in a single block
Series 21i/210i/210is	OPERATOR'S MANUAL (For Machining Center) (B-63614EN)	II.11.2	Multiple M commands in a single block
	OPERATOR'S MANUAL (For Lathe) (B-63604EN)	II.11.2	Multiple M commands in a single block
Series 20i	OPERATOR'S MANUAL (For Manual Milling Machine) (B-64204EN)	II.11.2	Multiple M commands in a single block
	OPERATOR'S MANUAL (For Manual Lathes) (B-64194EN)	II.11.2	Multiple M commands in a single block

8.4 HIGH-SPEED M/S/T/B INTERFACE

General

To accelerate M/S/T/B function execution, the high-speed M/S/T/B interface has simplified the transfer of the strobe and completion signals of the M/S/T/B functions.

Whether to use the usual system or high-speed system for strobe signal and completion signal handling can be specified by parameter MHI (No. 3001#7).

The description below uses the miscellaneous functions (M code commands) as an example. The same description applies to the spindle-speed function (S code), tool function (T code) and 2nd auxiliary function (B code).

Basic procedure

(1) Assume that the following program is given:

Mxx;
Myy;

(2) In response to an M command, the NC system sends out the code signals M00 to M31.

The CNC system inverts the logical level of the strobe signal MF, that is, from “0” to “1”, or from “1” to “0”.

(3) The CNC system inverts the strobe signal, then when the logical level of the auxiliary function completion signal MFIN becomes the same as the strobe signal, the CNC assumes the completion of PMC sequence.

With the usual method, the operation is assumed to be completed when a falling edge (“1” to “0”) of the M/S/T/B completion signal FIN is received after a rising edge (“0” to “1”) of the FIN signal is detected. This new system, on the other hand, assumes the operation has been completed upon detection of only one transition of the completion signal.

In addition, the usual system uses only one completion signal (FIN) common to the M/S/T/B functions. This new system uses a different completion signal for each of the M, S, T, and B functions; the completion signals for the M, S, T, and B functions are MFIN, SFIN, TFIN, and BFIN, respectively.

The Fig. 8.4 (a) below shows the timing chart of these signals with the new system. For comparison, Fig. 8.4 (b) shows the timing chart of the conventional system.

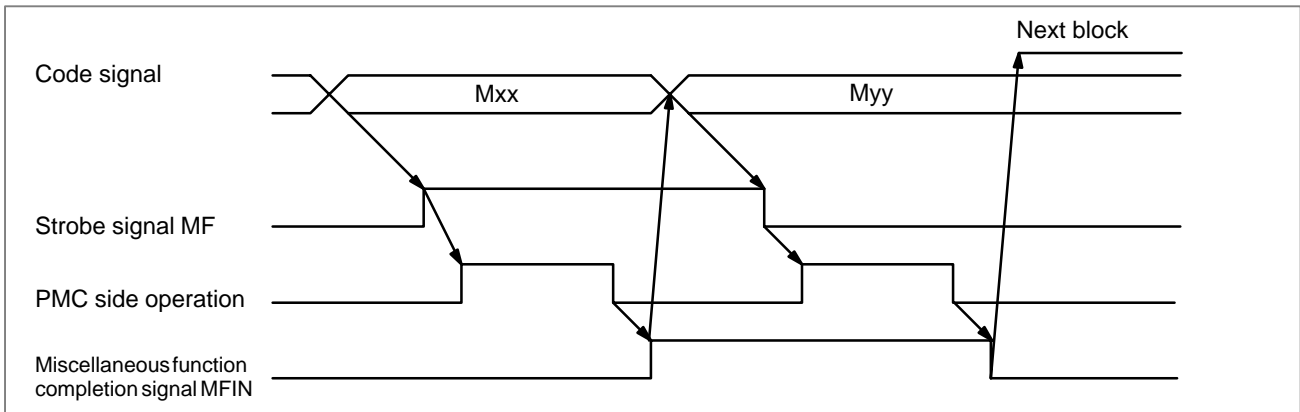

Fig. 8.4 (a) Timing chart of the high-speed system

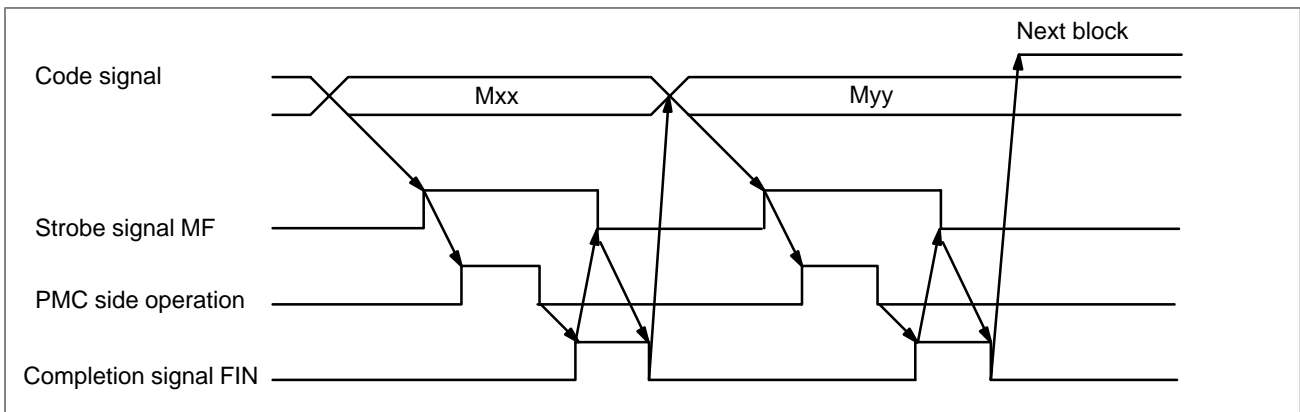

Fig. 8.4 (b) Timing chart of the usual system

A high-speed interface can also be used for multiple M commands issued for one block. This interface provides separate completion signals for each M code. They are called MFIN (the same name as for the single M command per block function), MFIN2, and MFIN3, respectively. The signal transfer sequence for multiple M codes per block is the same as that for a single M code per block.

The high-speed interface can also be used for the external operation function. In this case, special external operation signal EFD and completion signal EFIN are used. The procedure for sending and receiving these signals is identical to that for sending and receiving the strobe and completion signals of the miscellaneous function (M series).

Signal

Miscellaneous function completion signal MFIN <G005#0>

[Classification] Input signal

[Function] Reports that the execution of a miscellaneous function using the high-speed M/S/T/B interface is completed.

[Operation] For the operation and aprocedure of the contol unit when this signal turns to "1" and "0", see the description of "Basic procedure" above.

**Spindle function
completion signal
SFIN <G005#2>**

[Classification] Input signal

[Function] Reports that the execution of a spindle speed function using the high-speed M/S/T/B interface is completed.

[Operation] For the operation and procedure of the control unit when this signal turns to “1” and “0”, see the description of “Basic procedure” above.

**Tool function completion
signal TFIN <G005#3>**

[Classification] Input signal

[Function] Reports that the execution of a tool function using the high-speed M/S/T/B interface is completed.

[Operation] For the operation and procedure of the control unit when this signal turns to “1” and “0”, see the description of “Basic procedure” above.

**2nd auxiliary function
completion signal BFIN
<G005#4> (T series)
<G005#7> (M series)**

[Classification] Input signal

[Function] Reports that the execution of a second auxiliary function using the high-speed M/S/T/B interface is completed.

[Operation] For the operation and procedure of the control unit when this signal turns to “1” and “0”, see the description of “Basic procedure” above.

**2nd, 3rd M function
completion signals
MFIN2, MFIN3
<G004#4, #5>**

[Classification] Input signal

[Function] Indicate that when the high-speed interface is used for multiple M commands per block, the second to 3rd M functions have been completed.

[Operation] See “Basic procedure” for how the control unit operates and what it performs when the signal turns to “1” and “0”.

**External operation signal
for high-speed interface
(M series) EFD <F007#1>**

[Classification] Output signal

[Function] Indicates that positioning for the external operation function has been completed for the high-speed M, S, T, or B interface, and that another external operation is required.

[Operation] Refer to the description of the output conditions and procedure described in “basic procedure.”

**External operation
function completion
signal (M series) EFIN
<G005#1>**

[Classification] Input signal

[Function] Indicates that the external operation function has been completed for the high-speed M, S, T, or B interface.

[Operation] The “basic procedure” describes the procedure and operation of the control unit when the signal is set to 1 or 0.

Signal address

	#7	#6	#5	#4	#3	#2	#1	#0
G004			MFIN3	MFIN2				
G005	BFIN			BFIN	TFIN	SFIN	EFIN	MFIN
	#7	#6	#5	#4	#3	#2	#1	#0
F007							EFD	

Parameter

	#7	#6	#5	#4	#3	#2	#1	#0
3001	MHI							

MHI Exchange of strobe and completion signals for the M, S, T, and B codes
 0 : Normal
 1 : High-speed

Note

NOTE

- 1 The strobe signals MF, SF, TF, and BF are “0” when the power is turned on.
- 2 When the control unit is reset, MF, SF, TF, and BF are set to “0”.

Reference item

CONNECTION MANUAL (This manual)	8.1	Miscellaneous function/2nd auxiliary function
	8.3	Multiple M commands in a block
	11.8	External operation function

8.5 WAITING M CODE (TWO-PATH CONTROL)

General

Control based on M codes is used to cause one path to wait for the other during machining. By specifying an M code in a machining program for each path, the two paths can wait for each other at a specified block. When an M code for waiting is specified in a block for one path during automatic operation, the other path waits for the same M code to be specified before starting the execution of the next block.

A range of M codes used as M codes for waiting is to be set in the parameters (Nos. 8110 and 8111) beforehand.

Signal

No-wait signal NOWT <G063#1>

[Classification] Input signal

[Function] Specifies whether to synchronize the paths by the waiting M code.

[Operation] When this signal turns to “1” the paths are not synchronized by the M code. The M code for waiting specified in a machining program is ignored.

When this signal turns to “0”, the paths are synchronized by the M code. When the M code for waiting is specified for one path, the CNC waits for the corresponding M code of another path to be issued, then starts executing the next block.

Waiting signal WATO <F063#6>

[Classification] Output signal

[Function] Indicates that the CNC is waiting for the M code of either path 1 or 2.

[Output condition] This signal is “1” as long as:

- One path is waiting for another path. That is, the signal stays “1” for the period from when the M code for waiting is issued to one path to when the corresponding M code is issued to another path.

This signal is “0” as long as:

- Neither of the paths are waiting for the other.

Signal address

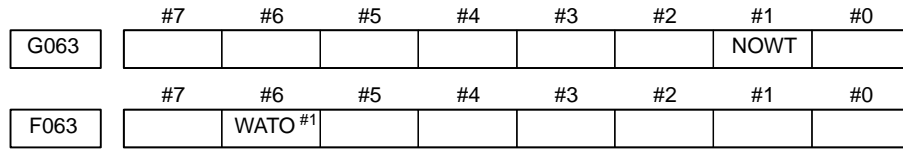

Parameter

8110	Waiting M code range (minimum value)
------	--------------------------------------

[Data type] Two-word

[Valid data range] 0 and 100 to 99999999

This parameter specifies the minimum value of the waiting M code. The waiting M code range is specified using parameter No. 8110 (minimum value) and parameter No. 8111 (maximum value).
 (parameter No. 8110) ≤ (waiting M code) ≤ (parameter No. 8111)

NOTE
 A value of 0 indicates that the waiting M code is not used.

8111	Waiting M code range (maximum value)
------	--------------------------------------

[Data type] Two-word

[Valid data range] 0 and 100 to 99999999

This parameter specifies the maximum value of the waiting M code.

Alarm and message

Number	Message	Description
160	MISMATCH WAITING M-CODE	Different M code is commanded in heads 1 and 2 as waiting M code. Modify the program.

Caution

CAUTION
 As for waiting M code, neither code signals nor strobe signal are output.

Reference item

Series 16i/18i/160i/180i/ 160is/180is	OPERATOR'S MANUAL (For Machining Center) (B-63534EN)	II.21.2	WAITING FOR PATHS
	OPERATOR'S MANUAL (For Lathe) (B-63524EN)	II.20.2	WAITING FOR TOOL POSTS

8.6 M CODE GROUP CHECK FUNCTION

General

This function checks whether combinations of M codes (up to three) specified in one block are correct.

The function has two purposes. One of the purposes is to alarm if an M code which must not be combined with any other M codes is combined with another. The other purpose is to alarm if an M code in a group is combined with another M code in the same group. These errors are reflected in P/S alarm No. 5016.

- **Setting the group data**

Pressing the  key, then the continuous menu key several times causes the [M CODE] soft key to appear. Pressing this soft key displays the screen shown in Fig. 8.6 (a).

M CODE GROUP SETTING				O0000	N0000
NO.	MCG	NO.	MCG	NO.	MCG
0000	0	0010	0	0020	0
0001	0	0011	0	0021	0
0002	0	0012	0	0022	0
0003	0	0013	0	0023	0
0004	0	0014	0	0024	0
0005	0	0015	0	0025	0
0006	0	0016	0	0026	0
0007	0	0017	0	0027	0
0008	0	0018	0	0028	0
0009	0	0019	0	0029	0
>					
MDI *****				00 : 00 : 00	
{ () { () { (M CODE) { () { (OPRT) }					

Fig. 8.6 (a)

Basically, item numbers correspond to M codes. However, there may be exceptions depending on parameter setting. (See descriptions of the relevant parameters.) The data specified on this screen remains until all parameters are cleared simultaneously. To go to the next page of the screen, use the [PAGE] key.

Pressing the [(OPRT)] soft key or the corresponding numeric key displays the soft keys shown in Fig. 8.6 (b). Searches for the desired item number and enter the data.

Semicolon “;” may be used for continuous data entry.

Data entry is enabled when PARAMETER WRITE ENABLE is set to “1” on the parameter setting screen.

>					
MDI *****				00 : 00 : 00	
{ (No. SRH) { () { () { () { () { (INPUT) }					

Fig. 8.6 (b)

For M codes which must be used separately from other M codes, always set their group number to “1”. Such M codes include M00, M01, M02, M30, M98, and M99. For M codes for which the CNC performs internal processing in addition to sending them to the machine, also set their group number to “1”. See Section 8.3 for details.

For M codes you do not need to check, leave them at an initial value of “0”.

The M codes can be set with a number from 0 to 127. Neither negative values nor decimal point can be specified.

● Parameter setting

Basically, item numbers 0 to 99 correspond to M00 to M99. For item numbers 100 and higher, parameter No. 3441 to 3444 can specify the corresponding M codes.

The initial values for these parameters are “0”.

3441	First of the M codes assigned to item numbers 100 to 199
3442	First of the M codes assigned to item numbers 200 to 299
3443	First of the M codes assigned to item numbers 300 to 399
3444	First of the M codes assigned to item numbers 400 to 499

[Data type] Two-word

[Valid data range] 0 to 99999999

If a parameter is specified as “0”, it is set to a value specified to the previous parameter plus 100. For example, if parameter No. 3441 is specified as “0”, it is internally set to “100”. If parameter No. 3442 is specified as “0” under this condition, it is internally set to “200”.

Negative values are assumed to be “0”.

Basically, these parameters can be specified as any value. However, the following conditions should be observed to save memory space.

$$X + 99 < Y, Y + 99 < Z, \text{ and } Z + 99 < W$$

where X = value specified for parameter No. 3441, Y = value specified for parameter No. 3442, Z = value specified for parameter No. 3443, and W = value specified for parameter No. 3444.

(Example of setting)

(i) No. 3441 = 0, No. 3442 = 0, No. 3443 = 0, No. 3444 = 0

In this case, these parameters are set to “100”, “200”, “300”, and “400” respectively. The item numbers correspond directly to the M codes. The group numbers for M500 and larger M codes are assumed to be “0” automatically.

(ii) No. 3441 = 200, No. 3442 = 0, No. 3443 = 500, No. 3444 = 800

In this case, parameter No. 3442 is set to “300”. Item numbers 100 to 299 correspond to M200 to M399, 300 to 399 correspond to M500 to M599, and 400 to 499 correspond to M800 to M899. The group numbers for M100 to M199, M400 to M499, M600 to M799, M900, and all M codes with higher numbers are automatically set to “0”.

(iii) No. 3441 = 234, No. 3442 = 345, No. 3443 = 456, No. 3444 = 567

In this case, item numbers 100 to 199 correspond to M234 to M333, 200 to 299 correspond to M345 to M444, 300 to 399 correspond to M456 to M555, and 400 to 499 correspond to M567 to M666. The group numbers for M100 to M233, M334 to M344, M446 to M455, M556 to M566, M667, and all M codes with higher numbers are automatically set to "0".

The examples above meet the setting conditions. With these settings, up to 500 M codes can be set.

Examples that do not meet the setting conditions follow.

(iv) No. 3441 = 200, No. 3442 = 50, No. 3443 = 100, No. 3444 = 600

In this case, item numbers 0 to 99 correspond to M00 to M99, 100 to 199 correspond to M200 to M299, and 400 to 499 correspond to M600 to M699. Item numbers 200 to 399 are meaningless. With these settings, only up to 300 M codes can be set.

(v) No. 3441 = 50, No. 3442 = 100, No. 3443 = 150, No. 3444 = 200

In this case, the correspondence between the item numbers and M codes is set up as listed below. With these settings, up to 300 M codes can be set. The group number for M300 and all M codes with higher numbers are automatically set to "0".

Item number	M code
0 - 49	0 - 49
50 - 99	Meaningless
100 -199	50 - 149
200 -249	Meaningless
250 -299	150 - 199
300 -349	Meaningless
350 -399	200 - 249
400 -449	Meaningless
450 -499	250 - 299

- Input/output with floppy cassettes
- Input

The file you want to read out should be set on the read station. First locate the file in the program screen in the EDIT mode. In this mode, display the M code group setting screen. See Section 8.2, Part III of the operator's manual for how to locate the file.

On the soft key screen shown in Fig. 8.6 (b), pressing the continuous menu key several times displays the soft keys shown in Fig. 8.6 (c).

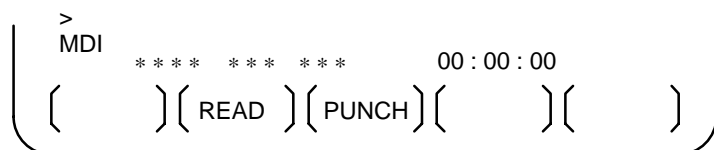

Fig. 8.6 (c)

Now pressing the [READ] key displays the soft keys shown in Fig. 8.6 (d).

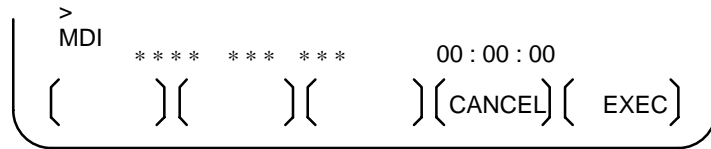

Fig. 8.6 (d)

To execute the read operation, just press the [EXEC] key.

• Output

Pressing the [PUNCH] key on the screen shown in Fig. 8.6 (c) displays the soft keys shown in Fig. 8.6 (d). To execute the punch operation, just press the [EXEC] key.

After this operation, you can confirm that the file M CODE GROUP is output, by searching through floppy cassette files. The output data has a format with 60000 added to the item number:

N60xxxPyyy (where xxx = 0 to 499, yyy = 0 to 127)

Parameter

3441	First of the M codes assigned to item numbers 100 to 199
3442	First of the M codes assigned to item numbers 200 to 299
3443	First of the M codes assigned to item numbers 300 to 399
3444	First of the M codes assigned to item numbers 400 to 499

[Data type] Two-word

[Valid data range] 0 to 99999999

Alarm and message

Number	Message	Description
5016	ILLEGAL COMBINATION OF M CODE	M codes which belonged to the same group were specified in a block. Alternatively, an M code which must be specified without other M codes in the block was specified in a block with other M codes.

Reference item

Series 16i/18i/160i/180i/ 160is/180is	OPERATOR'S MANUAL (For Machining Center) (B-63534EN)	II.11.3	M CODE GROUP CHECK FUNCTION
	OPERATOR'S MANUAL (For Lathe) (B-63524EN)	II.11.3	M CODE GROUP CHECK FUNCTION

9 SPINDLE SPEED FUNCTION



9.1 SPINDLE SPEED FUNCTION (S CODE OUTPUT)

General

When up to five digits are specified after address S, code and strobe signals are sent out and used to control the spindle speed. The code signals are retained until another S code is issued.

One S code is used for each block. Parameter No. 3031 can be used to specify the maximum number of digits. If a number greater than the maximum number is specified, an alarm can be raised.

Signal

Refer to section 8.1.

Parameter

3031	Allowable number of digits for the S code
------	---

[Data type] Byte

[Valid data range] 1 to 5

Set the allowable numbers of digits for the S codes.

Note

NOTE

- 1 When a move command and miscellaneous function are specified in the same block, the commands are executed in one of the following two ways:
 - i) Simultaneous execution of the move command and miscellaneous function commands.
 - ii) Executing miscellaneous function commands upon completion of move command execution.
 The selection of either sequence depends on the PMC processing sequence.
- 2 For S code output when the spindle serial output/spindle analog output is used, refer to section 9.3.

9.2 SPINDLE SERIAL OUTPUT/SPINDLE ANALOG OUTPUT

General

There are two types of spindle motor control interfaces, spindle serial output and spindle analog output.

The spindle serial output interface can control up to two serial spindles. The spindle analog output interface can control one analog spindle.

The table below lists the relationships between the spindle control interfaces and the configuration of the spindle.

Spindle serial output	Spindle analog output	First spindle	Second spindle	Third spindle
○	○	First serial spindle The PC can be used.	Second serial spindle The PC can be used. (*)	Analog spindle The PC cannot be used.
○	×	First serial spindle The PC can be used.	Second serial spindle The PC can be used. (*)	—
×	○	Analog spindle The PC can be used.	—	—
×	×	See Section 9.1. ⇒ Controlled by the PMC using an external interface.		

- PC = position coder
- (*) The multispindle function is necessary to use the position coder on the second spindle.
- See section 15.4 or 9.10 for how to control the speed of the second and third spindles.
- In addition, three or four serial spindles can be connected through the use of the three/four-spindle serial output option.
Refer to Section 9.15 “Three/four-spindle serial output,” for details.

The table below lists the relationship between the spindles and functions.

○=Available ×=Unavailable

Function \ Spindle	Serial spindle		Analog spindle	
	First serial spindle	Second serial spindle	When used as the first spindle (with no serial SP)	When used as the third spindle (with a serial SP)
Thread cutting/feed per revolution (synchronous feed)	○	○ (*1)	○	×
Constant surface speed control	○	○ (*1)	○	×
Spindle speed fluctuation detection	○	○ (*1)	○	×
Actual spindle speed output (T series)	○	○ (*1)	○	×
Spindle positioning (T series)	○	×	○	×
Cs contour control	○	○	×	×
Multi-spindle (*2)	○ (First spindle)	○ (Second spindle)	×	○ (Third spindle)
Rigid tapping	○	○ (*1)	○	×
Spindle synchronous control	○ Master (*3)	○ Slave (*3)	×	×
Spindle control unit functions, such as spindle orientation, spindle output switching, spindle switching, and etc. (*4)	○	○	○	○
Polygon turning (T series) (using the servo motor axis and spindle)	○	○ (*1)	○	×
Polygon turning between spindles (T series) (using two spindles)	○ (*5)	○ (*5)	×	×
Spindle output control by the PMC	○	○	○	○

NOTE

- 1 The multispindle function is necessary. The function cannot be used for the first and second spindles simultaneously.
- 2 The multispindle function can control the speed of three spindles and switch the feedback signal between two position coders. It also can work without the second or third spindle.
- 3 For a two-path lathe application, the first spindle on tool post 1 is the master, and the first spindle on tool post 2 is the slave. The second spindle of either tool post cannot be used in spindle synchronization.
- 4 These functions belong to the spindle control unit. They cannot be used unless the spindle control unit supports those functions.
- 5 Spindle polygon turning is available for a combination of the spindle of tool post 1 and the spindle of tool post 2 for the two-path lathe application.

The signals and parameters for spindle speed control are common to both spindle serial output and spindle analog output. (See Section 9.3.)

The table below lists the differences related to direct control of the spindle control unit.

	Spindle control unit for spindle serial output interface	Spindle control unit for spindle analog output interface
Parameters for the spindle control unit	Specified as CNC parameters (4000 to 4351/S1, S2) Used after being transferred to the spindle control unit	Directly specified for the spindle control unit
Control signal for the spindle control unit	Connected to the PMC via the CNC G0070 to G0073 and F0045 to F0048: Addresses for the first spindle G0074 to G0077 and F0049 to F0052: Addresses for the second spindle	Connected to the PMC via an external contact
Spindle speed command interface	Digital data in a range from 0 to \pm maximum spindle motor speed	Analog voltage from 0 to ± 10 V (excluding portion for offset voltage adjustment)
Position coder interface	Connected to the CNC via the spindle control unit	Connected directly to the CNC

Signal

· Spindle control unit signals for the serial spindle

<G0070 to G0073> (input), <F0045 to F0048> (output)

→ for the first serial spindle

<G0074 to G0077> (input), <F0049 to F0052> (output)

→ for the second serial spindle

These addresses are on the CNC. Actually, however, they are input/output signals for the spindle control unit for the serial spindle.

For details of the signals belonging to these addresses, refer to the manuals for the serial spindle:

FANUC SERVO AMPLIFIER *αi* series Descriptions (B-65282EN)

FANUC AC SPINDLE MOTOR *αi* series Descriptions (B-65272EN)

FANUC AC SPINDLE MOTOR *αi* series Parameter Manual (B-65280EN)

Signal address

● For 1st SERIAL SPINDLE

	#7	#6	#5	#4	#3	#2	#1	#0
G070	MRDYA	ORCMA	SFRA	SRVA	CTH1A	CTH2A	TLMHA	TLMLA
G071	RCHA	RSLA		SOCNA	MCFNA	SPSLA	*ESPA	ARSTA
G072	RCHGA	MFNHGA	INCMDA	OVRI DA	DEFMDA	NRROA	ROTA A	INDXA
G073						MPOFA	SLVA	MORCMA
	#7	#6	#5	#4	#3	#2	#1	#0
F045	ORARA	TLMA	LDT2A	LDT1A	SARA	SDTA	SSTA	ALMA
F046	MORA2A	MORA1A	PORA2A	SLVSA	RCFNA	RCHPA	CFINA	CHPA
F047							INCSTA	PC1DEA
F048								

● For 2ND SERIAL SPINDLE

	#7	#6	#5	#4	#3	#2	#1	#0
G074	MRDYB	ORCMB	SFRB	SRVB	CTH1A	CTH2B	TLMHB	TLMLB
G075	RCHB	RSLB		SOCNB	MCFNB	SPSLB	*ESPB	ARSTB
G076	RCHGB	MFNHGB	INCMDB	OVRI DB	DEFMDB	NRROB	ROTA B	INDXB
G077						MPOFB	SLVB	MORCMB
	#7	#6	#5	#4	#3	#2	#1	#0
F049	ORARB	TLMB	LDT2B	LDT1B	SARB	SDTB	SSTB	ALMB
F050	MORA2B	MORA1B	PORA2B	SLVSB	RCFNB	RCHPB	CFINB	CHPB
F051							INCSTB	PC1DEB
F052								

Parameter

• Connection of serial spindle control unit

	#7	#6	#5	#4	#3	#2	#1	#0
3701				SS2			ISI	

[Data type] Bit

ISI Specifies whether the serial spindle interface is used.

0 : Used

1 : Not used

NOTE

- 1 This parameter is enabled only when the serial spindle interface option is provided. The parameter is used when the CNC is started after serial spindle interface control is temporarily disabled during startup adjustment of the CNC. This bit should normally set to be 0.
- 2 When Serial spindle is used with Analog spindle and this parameter is set to "1", Analog spindle becomes 1st spindle.

SS2 The number of connections in serial spindle control

0 : 1

1 : 2

NOTE

To connect two serial spindles, set jumper S1 on the 1st serial spindle control unit to B.
(For S series SERIAL SPINDLE AMPLIFIER)

• Parameters of serial spindle control unit

No. 4000 to 4351: S1 → For 1st serial spindle
S2 → For 2nd serial spindle

The above parameters are on the CNC, but actually they are used for the spindle control unit of serial spindle.

For details of these parameters, refer to the following manual:

FANUC AC SPINDLE MOTOR α i series DESCRIPTIONS MANUAL
(B-65272EN)

FANUC AC SPINDLE MOTOR α i series PARAMETER MANUAL
(B-65280EN)

Alarm and message

Number	Message	Contents
749	S-SPINDLE LSI ERROR	<p>It is serial communication error while system is executing after power supply on. Following reasons can be considered.</p> <ol style="list-style-type: none"> 1) Optical cable connection is fault or cable is not connected or cable is cut. 2) MAIN CPU board or option 2 board is fault. 3) Spindle amp. printed board is fault. 4) The spindle amplifier is under an abnormal condition. (The SPM indication is A, A1, A2, or the like, depending on the type of the abnormality.) <p>If this alarm occurs when CNC power supply is turned on or when this alarm can not be cleared even if CNC is reset, turn off the power supply also turn off the power supply in spindle side.</p> <p>If the spindle amplifier is under an abnormal condition, check the SPM indication (A, A1, A2, or the like). Then, refer to the FANUC SERVO MOTOR <i>ai</i> series MAINTENANCE MANUAL (B-65285EN) or FANUC SERVO MOTOR α series MAINTENANCE MANUAL (B-65165E) to solve the problem.</p>
750	SPINDLE SERIAL LINK START FAULT	<p>This alarm is generated when the spindle control unit is not ready for starting correctly when the power is turned on in the system with the serial spindle.</p> <p>The four reasons can be considered as follows:</p> <ol style="list-style-type: none"> 1) An improperly connected optic cable, or the spindle control unit's power is OFF. 2) When the NC power was turned on under alarm conditions other than SU-01 or AL-24 which are shown on the LED display of the spindle control unit. In this case, turn the spindle amplifier power off once and perform startup again. 3) Other reasons (improper combination of hardware) This alarm does not occur after the system including the spindle control unit is activated. 4) The second spindle (when SP2, bit 4 of parameter No. 3701, is 1) is in one of the above conditions 1) to 3). <p>See diagnostic display No. 409 for details.</p>
752	FIRST SPINDLE MODE CHANGE FAULT	<p>This alarm is generated if the system does not properly terminate a mode change. The modes include the Cs contouring, spindle positioning, rigid tapping, and spindle control modes. The alarm is activated if the spindle control unit does not respond correctly to the mode change command issued by the NC.</p>
754	SPINDLE-1 ABNORMAL TORQUE ALM	Abnormal first spindle motor load has been detected.
762	SECOND SPINDLE MODE CHANGE FAULT	Refer to alarm No. 752.(For 2nd axis)
764	SPINDLE-2 ABNORMAL TORQUE ALM	Same as alarm No. 754 (for the second spindle)

DIAGNOSIS SCREEN

● Information on spindle control

	#7	#6	#5	#4	#3	#2	#1	#0
400				SAI	SS2	SSR	POS	SIC

SIC 0: No module is present for spindle serial output.

1: A module for spindle serial output is present.

POS 0: No module is present for spindle analog output.

1: A module for spindle analog output is present.

SSR 0: Spindle serial output is not used.

1: Spindle serial output is used.

SS2 0: The second spindle is not used with spindle serial output.

1: The second spindle is used with spindle serial output.

SAI 0: Spindle analog output is not used.

1: Spindle analog output is used.

401	Alarm condition for the first serial spindle (AL-??)
-----	--

402	Alarm condition for the first serial spindle (AL-??)
-----	--

● Communication error on spindle serial output interface

	#7	#6	#5	#4	#3	#2	#1	#0
408	SSA		SCA	CME	CER	SNE	FRE	CRE

CRE 1 : CRC error (warning)

FRE 1 : Framing error (warning)

SNE 1 : Mismatch between sending and receiving sections

CER 1 : Abnormal reception

CME 1 : No answer during auto scanning

SCA 1 : Communication error in the spindle amplifier

SSA 1 : System error in the spindle amplifier

(These errors are reflected in spindle alarm 749. They are caused by noise, disconnection, or instantaneous power interruption.)

● Information related to the activation of the spindle serial output interface

	#7	#6	#5	#4	#3	#2	#1	#0
409					SPE	S2E	S1E	SHE

SHE 1 : Abnormal operation in the serial spindle communication module of the CNC

S1E 1 : Abnormal operation on the first spindle during activation

S2E 1 : Abnormal operation on the second spindle during activation

SPE 1 : Serial spindle parameter not meeting activation conditions

(These errors are reflected in spindle alarm 750.)

● **Load and speed meter readings for the serial spindle**

410	First serial spindle: Load meter reading (%)
411	First serial spindle: Speed meter reading (min ⁻¹)
412	Second serial spindle: Load meter reading (%)
413	Second serial spindle: Speed meter reading (min ⁻¹)

To display the load and speed meter readings, the following parameters must be specified correctly.

Maximum motor speed: Parameter No. 4020 (main) and 4196 (sub)

Load meter reading at maximum output:

Parameter No. 4127 (main) and 4276 (sub)

NOTE

The spindle switch function is used for main/sub switching. Select main if the spindle switch function is not used.

● **Position error display during spindle synchronization**

414	Master spindle motion error during spindle synchronization
415	Slave spindle motion error during spindle synchronization
416	Absolute value of synchronization error during spindle synchronization

The display for diagnosis No. 414 to 416 are in pulse units (one pulse = 360/4096 degrees)

● **Position error display during spindle synchronization**

417	First serial spindle: Position coder feedback information
418	First serial spindle: Position error
419	Second serial spindle: Position coder feedback information
420	Second serial spindle: Position error

The above display data is the information obtained directly from the serial spindle control unit.

9.3 SPINDLE SPEED CONTROL

General

This section describes spindle speed control. It also explains the position coder and the spindle speed arrival signal (SAR).

Command flow of spindle speed control

The following chart summarizes spindle speed control.

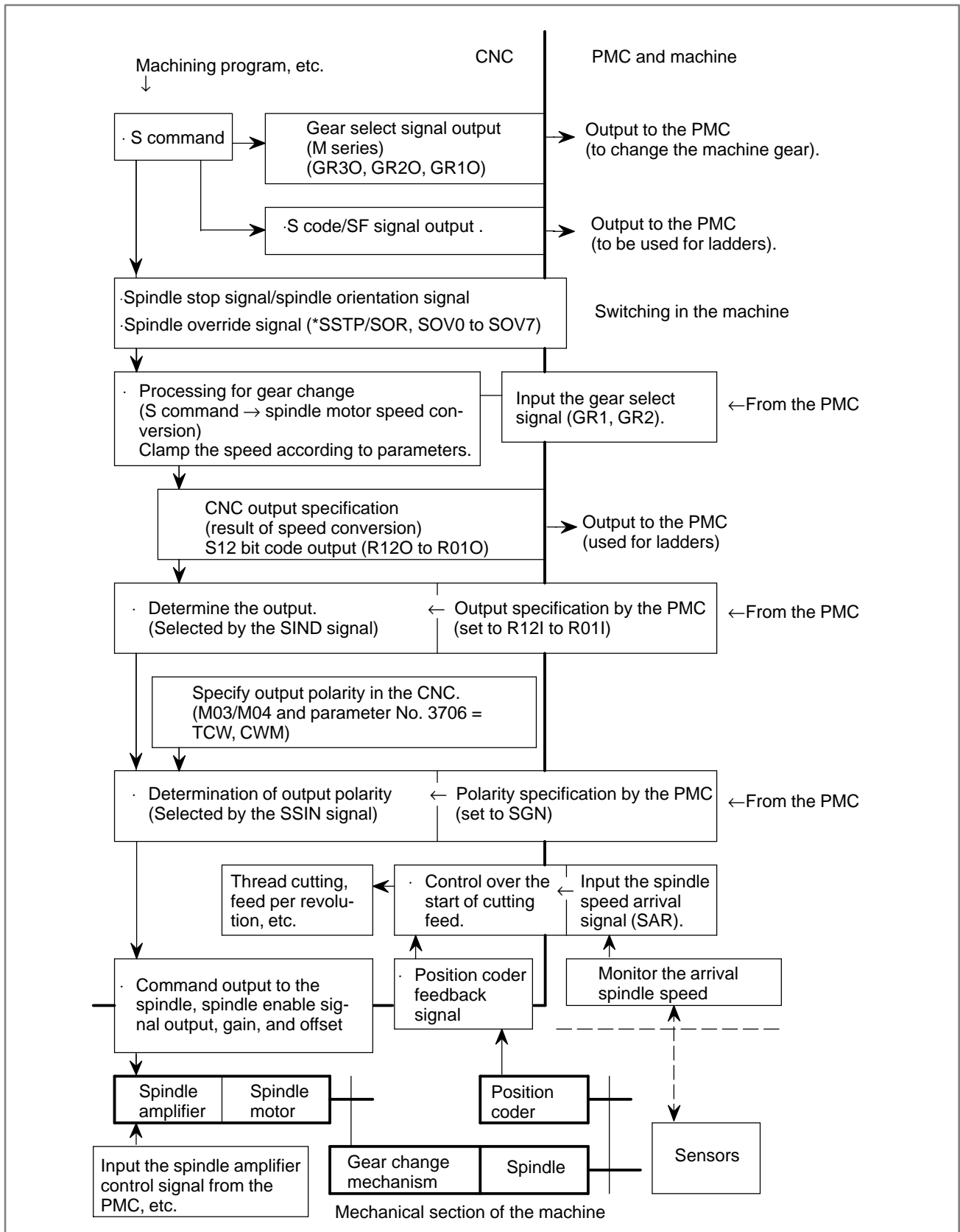

- **S command**

The S command specifies the spindle speed entered from machining programs, etc. for the CNC.

For constant surface speed control (during G96 mode), the CNC converts the specified surface speed to the spindle speed.

In the M series with bit 4 (GTT) of parameter No. 3706 = 0 without the constant surface speed control option, the CNC specifies the gear stage for the desired spindle speed to the PMC according to parameter No. 3741, 3742, and 3743, and the S command.

(GR30, GR20, GR10 <F034#2, #1, #0>)

- **S code/SF signal output**

With the spindle serial output or spindle analog output option, the spindle control function in the CNC converts the S command value to the output value for the spindle motor. For correspondence to gear change and constant surface speed control, the S code/SF signals output is different as follows in case of the spindle serial output and spindle analog output are not used.

M series → Outputs the S code.

The SF signal is output only when the CNC directs the PMC to change the gear.

T series → Outputs neither S code nor SF signal.

(This is because the S code is not always the spindle speed when the constant surface speed control option is used.)

If you use the S code for processing in the PMC ladder, you must specify parameters related to parameter No. 3705.

- **Spindle stop signal (*SSTP)**

This signal sets the S command value in the CNC to 0. If the CNC is specifying the spindle output (see descriptions on the SIND signal), this signal sets the speed command for the spindle to 0.

Even if the spindle stop signal is not used, the signal must be set to logical 1 for the CNC to perform spindle speed control.

- **Spindle orientation signal (SOR)**

If the spindle orientation signal is logical 1 and the spindle stop signal is logical 0, the spindle rotates in the direction specified by bit 5 (ORM) of parameter No. 3706 at a constant speed specified by parameter No. 3732.

Because the spindle rotates at a constant speed regardless of the gear stage, this signal can be used to rotate the spindle to drive the stopper or pin during mechanical spindle positioning.

For the M series, setting parameter GST (bit 1 of parameter No. 3705) enables the spindle motor to rotate at a constant speed at an M type gear shift. This function can be used for gear shifting because it maintains a constant speed of the gear change mechanism.

- **Spindle speed override signal (SOV00 to SOV07)**

This signal specifies an override of 0% to 254% for the specified S value for spindle control.

However, the spindle speed override function is disabled when the CNC is in the following state:

Tapping cycle (M series : G84, G74 T series : G84, G88)

Thread cutting (M series : G33 T series : G32, G92, and G76)

When the spindle speed control is performed but the spindle speed override is not used, set the override value to 100%.

● **Processing for gear changing**

Although the S command contains the spindle speed, the object that is actually controlled is the spindle motor. Therefore, the CNC must have some provision to detect the gear stage between the speed and spindle motor.

There are two types of gear selection methods:

M type

The CNC selects a gear stage according to the range of speed for each gear stage previously specified in a parameter, as directed by the S command, and informs the PMC of the selected gear stage (one of the three gear stages) using the gear select signal output (GR30, GR20, GR10).

Also, the CNC outputs the spindle speed based on the selected gear stage (output as the gear select signal).

T type

The gear stage (one of the four gear stages) being currently used by the machine is specified by the gear select signal inputs (GR1, GR2).

The machine determines which gear to use.

The CNC outputs the appropriate speed command for the selected gear range.

● **Selection of gear change system**

The M series system can use either M or T type.

M type ← Without constant surface speed control option, and bit 4 (GTT) of parameter No. 3706 = 0

T type ← With constant surface speed control, or bit 4 (GTT) of parameter No. 3706 = 1

The T series system can use only T type.

● **Details of M type (Output of GR10, GR20, GR30)**

By specifying from S0 to S99999 in memory or MDI operation, the CNC outputs a command corresponding to the spindle speed. There is a two-speed (GR10 and GR20) or three-speed range (GR10, GR20, GR30), set by parameter nos. 3741-3743, and the gear selection signal is output simultaneously. When the gear selection signal is changed, the SF signal is output at the same time (parameter SFA no. 3705#6).

The meaning of the gear signals is shown below:

	Gear 2-stage	Gear 3-state	Remarks
GR10	Low	Low	Low: Low Gear
GR20	High	Middle	Middle: Middle Gear
GR30		High	High: High Gear

The speed commands output to the spindle motor are as follows:

- For the serial spindle, the speed commands are processed as values 0 to 16383 between the CNC and spindle control unit.
- For the analog spindle, the speed commands are output to the analog voltage signal SVC as analog voltages 0 to 10 V.

The following descriptions exemplify the analog spindle. However, they can be applied to the serial spindle on the assumption that spindle motor speed with analog voltage 10 V corresponds to the maximum spindle motor speed.

- M type gear change method A (Fig. 9.3 (a))

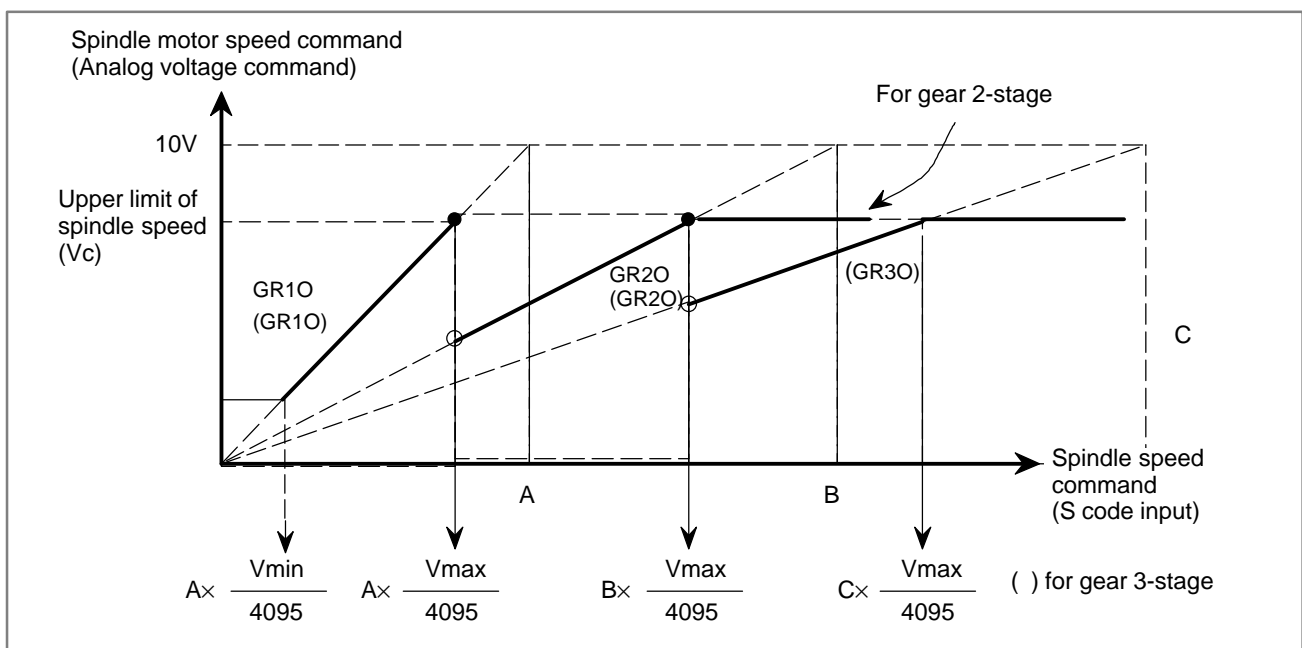

Fig. 9.3 (a) S code input and output voltage

Set the following values as parameters:

- Constant V_{max} : for upper limit of spindle speed (parameter No. 3736)

$$V_{max}=4095 \times \frac{\text{Upper limit of spindle speed}}{\text{Spindle speed at command voltage 10V}}$$

- Constant V_{min} ; for lower limit of spindle speed (parameter No. 3735)

$$V_{min}=4095 \times \frac{\text{Lower limit of spindle speed}}{\text{Spindle speed at command voltage 10V}}$$

- Spindle speed A (min^{-1}); at command voltage 10V and low gear (parameter no. 3741)
- Spindle speed B (min^{-1}); at command voltage 10V and high gear (or middle-high gear) (parameter no. 3742)
- Spindle speed C (min^{-1}); at command voltage 10V and high gear (parameter no. 3743)

NOTE

If a specified voltage of 10 V is already higher than the acceptable input voltage for the spindle drive system, calculate the spindle speed that corresponds to 10 V using a proportional calculation method and use it instead. Now, in response to the specified S code, the speed command and gear select commands (GR30, GR20, GR10) are output to the spindle motor as shown in Fig. 9.3. (a).

- Gear change point during tapping cycle mode (G84, G74)

In case of G84 (tapping cycle) or G74 (counter tapping cycle) the gear shift speed is changed by parameter SGT(No. 3705#3). In this case, gear shift is performed at the speed set by parameter nos. 3761 and 3762 (Fig. 9.3 (b)).

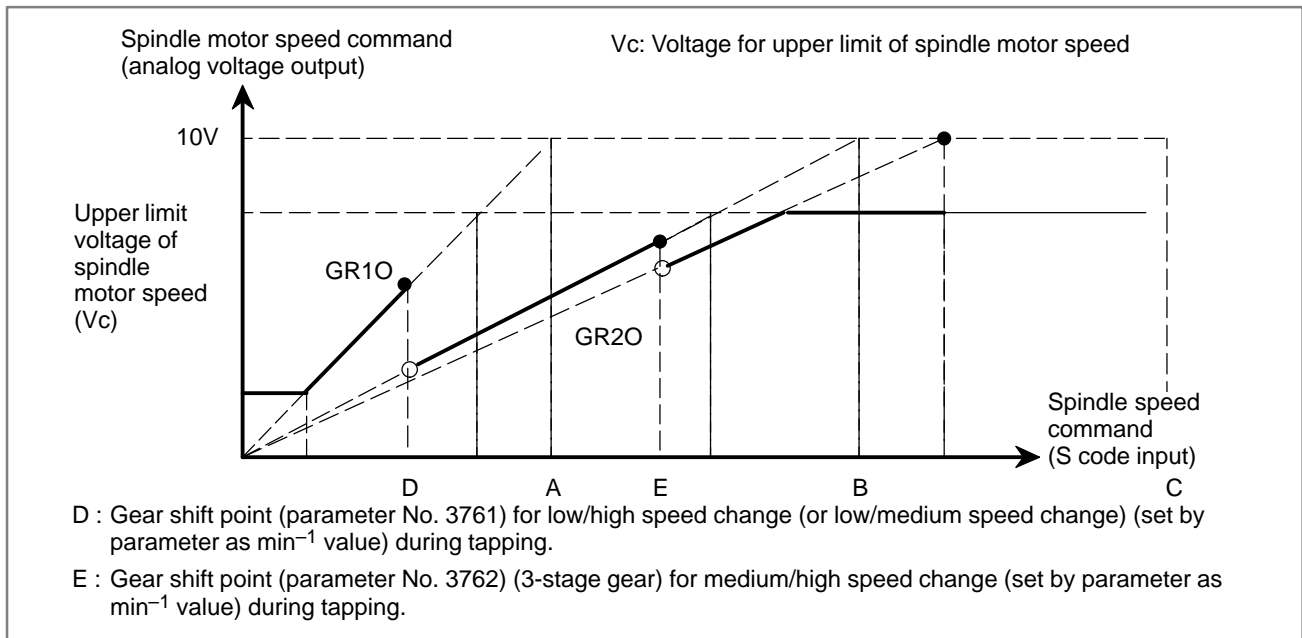

Fig. 9.3 (b) S code input and output voltage (in tapping)

- M type gear change method B (M series) (Fig. 9.3 (c))

The speed (min^{-1}) at which the low-speed and the high-speed gears are changed over can be set as a parameter (No.3751, 3752) by setting parameter SGB (No. 3705# 2). When a 3-stage gear is used, it is possible to set the speeds (min^{-1}) for switching low-speed and medium-speed gears, and medium-speed and high-speed gears, using parameters No. 3751, 3752.

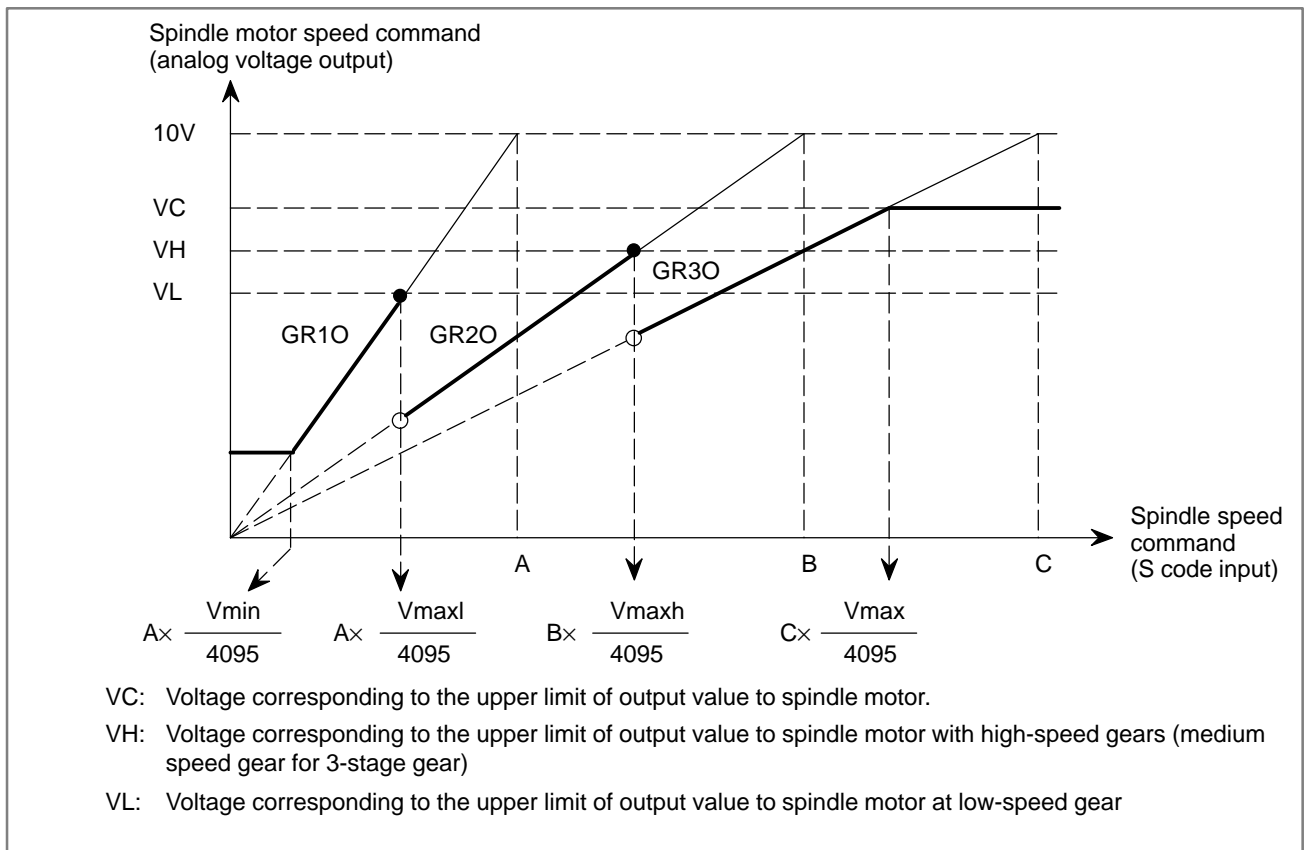

Fig. 9.3 (c) M type gear change B

When using this function, set the following parameters:

- Constant V_{max} (Parameter No.3736) related to the upper limit of spindle motor speed (min^{-1})

$$V_{max} = 4095 \times \frac{\text{Upper limit of spindle motor speed (min}^{-1}\text{)}}{\text{Spindle motor speed (min}^{-1}\text{) when the command voltage is 10V}}$$

- Constant V_{min} (Parameter No. 3735) related to the lower limit of spindle motor speed (min^{-1})

$$V_{min} = 4095 \times \frac{\text{Lower limit of spindle motor speed (min}^{-1}\text{)}}{\text{Spindle motor speed (min}^{-1}\text{) when the command voltage is 10V}}$$

- Constant V_{maxl} (Parameter No. 3751) related to the upper limit of spindle motor speed (min^{-1}) with low-speed gears

$$V_{maxl} = 4095 \times \frac{\text{Upper limit of spindle motor speed (min}^{-1}\text{) with low-speed gears}}{\text{Spindle motor speed (min}^{-1}\text{) when the command voltage is 10V}}$$

- Constant V_{maxh} (Parameter No. 3752) related to the upper limit of spindle motor speed (min^{-1}) with high-speed gears (medium-speed gear for 3-stage gear)

$$V_{maxh} = 4095 \times \frac{\text{Upper limit of spindle motor speed (min}^{-1}\text{) with high-speed gears (medium-speed gear for 3-stage gear)}}{\text{Spindle motor speed (min}^{-1}\text{) when the command voltage is 10V}}$$

- Spindle speed A (Parameter No.3741) (min^{-1}) with low-speed gears when the command voltage is 10V
- Spindle speed B (Parameter No.3742) (min^{-1}) with high-speed gears when the command voltage is 10V (medium-speed gear for 3-stage)
- Spindle speed C (Parameter No.3743) (min^{-1}) with high-speed gears when the command voltage is 10V (3-stage gear)

Spindle motor speed commands (0 to 10V) and gear selecting signals (GR1O, GR2O, GR3O) are issued on each S code command as shown in the figure:

CAUTION

- 1 In a tapping cycle when parameter SGT (No. 3705 #3) is set, the gears are changed over at the gear changing point for tapping.
- 2 For this function (parameter SGB=1 (No. 3705#2)), when only one-stage gear is used, the voltage corresponding to the upper limit value to the spindle motor is calculated using V_{maxl} , and when 2-stage gear is used, it is calculated according to V_{maxh} . Therefore, when SGB is 1, set V_{maxl} when only one-stage gear is used, V_{maxl} and V_{maxh} when 2-stage gear is used.

• Time chart

When S code is commanded, the I/O signal time chart is :

- When Gear select signal does not change

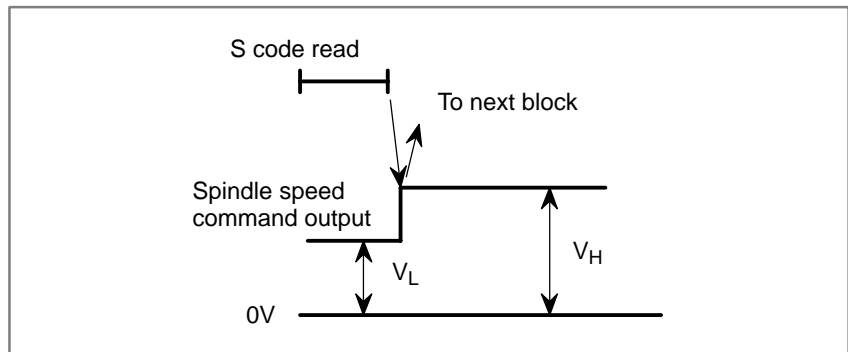

Fig. 9.3 (d) Time chart when gear select signal does not change

In this case, the SF signal is not output and the CNC advances to the next block automatically after the next spindle speed command is output.

- When Gear select signal change

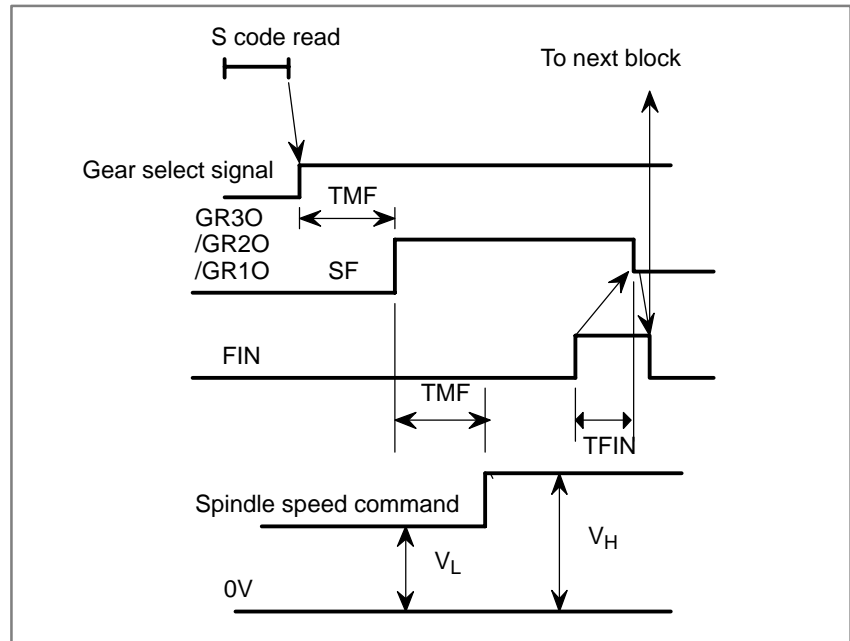

Fig. 9.3 (e) Time chart when gear select signal changes

In this case, the gear select signal is output; after elapse of the time constant set by parameter (TMF), the SF signal is output. After another TMF elapse, the spindle speed command is output. On the PMC side, change the gears by this signal, and return the FIN signal after the end of gear change. The time chart for SF and FIN signals is the same as in S code output. TMF, set by parameter No. 3010, is common to M, S and T functions.

Moreover, specifying bit 6 (SFA) of parameter No. 3705 can specify that the SF signal be output even if no gear change is used.

- Details of T type (Input of GR1, GR2)

To perform the T type gear change, the maximum spindle speed for each gear side must be set in parameter No. 3741-3744.

The gear select signal is a 2 bit code signal (GR1, GR2). The relationship between the signal and gear number is :

GR1	GR2	Gear No.	Parameter No. for max. spindle speed
0	0	1	No. 3741
1	0	2	No. 3742
0	1	3	No. 3743
1	1	4	No. 3744

The following descriptions apply to the analog spindle. Like the descriptions of the M type, they also apply to the serial spindle on the assumption that spindle motor speed with analog voltage 10 V corresponds to the maximum spindle motor speed.

In addition, for the speed command output to the spindle motor, analog voltages 0 to 10 V for analog spindle control correspond to digital data 0 to 16383 for serial spindle control. However, it might be easier if you consider them code signals from 0 to 4095 for convenience sake without distinguishing between serial and analog spindles.

Assume that gear switching is two stage switching. If the spindle speed with the output voltage 10 V is 1000 min^{-1} for the low speed gear (G1) and 2000 min^{-1} for the high speed gear (G2), set these speeds by the parameter No. 3741, 3742. In this case, the analog voltage has the linear relationship shown below.

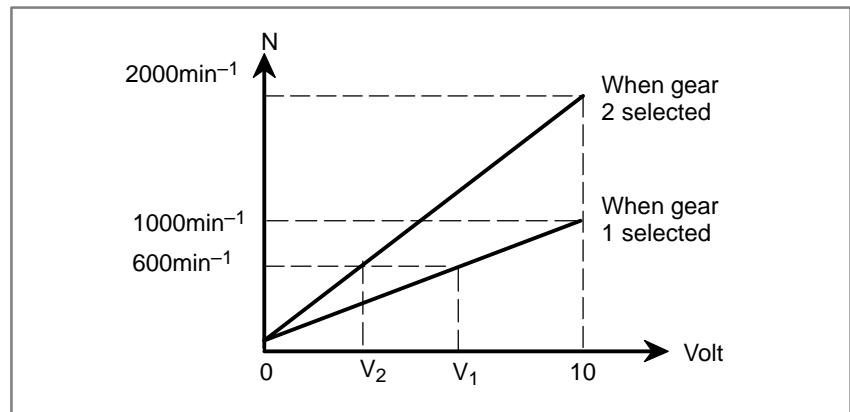

When spindle speed $S=600$ is given, V_1 (for G1) or V_2 (for G2) is calculated inside the CNC and output to the machine side.

$$V_1: 6(\text{V})$$

$$V_2: 3(\text{V})$$

The value of output voltage V is calculated automatically from the following equations:

$$V = \frac{10N}{R}$$

R: Spindle speed at 10V output voltage

N: Spindle speed given by S command

This is equivalent to the G97 mode for constant surface speed control.

See Section 9.5 for operations during the constant surface speed control mode (G96).

In addition, parameter No. 3772 (upper limit to the spindle speed) can specify speed clamping for all gear positions.

Reference→ Block Diagram for Analog Voltage Output

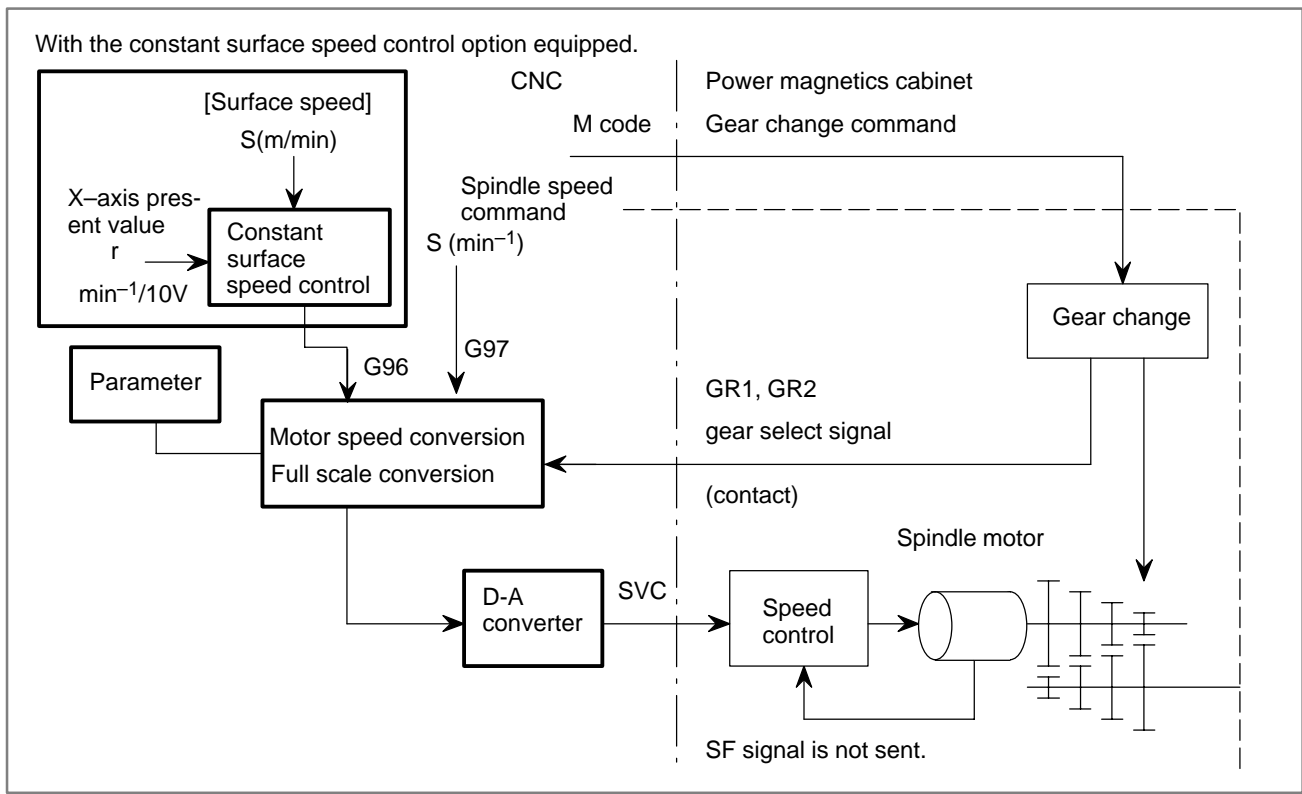

- **Determination of output polarity SSIN/SGN (Input)**

Using the above processing for gear change, the CNC calculates the speed command output to the spindle motor that is necessary to obtain the specified spindle speed with the gear.

For either serial spindle or analog spindle control, the calculation results are output as the S12 bit code signal from 0 to 4095 to the PMC.

(R120 to R010<F037#3 to F036#0>)

After the calculation results are received, the SIND signal <G033#7> determines which is to be used, the speed command output calculated by the CNC or the data specified in the PMC. Thus the speed command output to the spindle motor is determined. (See also Section 15.4.)

- **Determination of output polarity SSIN/SGN (Input)**

The speed command output to the spindle motor is determined as described above, but the actual output polarity is determined by the CNC as follows:

- If bit 7 (TCW) of parameter No. 3706 = 0
→ Determined according to bit 6 (CWM) of parameter No. 3706
- If bit 7 (TCW) of parameter No. 3706 = 1
→ Determined according to bit 6 (CWM) of parameter No. 3706 and M03/M04 given to the CNC

After that, the SSIN signal <G033#6> determines which is to be used, the output polarity calculated by the CNC or the polarity specified in the PMC. In this way, the polarity of the speed command output to the spindle motor is determined. (See also Section 15.4.)

Keep the following in mind: Even with bit 7 (TCW) of parameter No. 3706 = 1, the CNC cannot determine the output polarity if it has not issued M03/M04, and therefore, actual output does not work even if the speed command has been specified.

- **Command output to spindle**

According to the speed command output and the polarity determined so far, the command is sent to the spindle control unit as follows:

 - For serial spindle → Digital data 0 to ± 16383
 - For analog spindle → Analog voltage 0 to ± 10 V

- **Requirement of output**

After power is switched on, a nonzero command is output to the spindle only when the following conditions are met: A nonzero spindle speed command is specified, and the output polarity is determined.

With bit 7 (TCW) of parameter No. 3706 = 1, no command output is sent to the spindle, until an M03/M04 is issued because the output polarity is not determined.

- **Requirement to stop output**

The command output to the spindle is reset to 0 when a command to specify so (such as *SSTP = 0 or S0 command) is issued.

M05, emergency stop, or reset does not cause the CNC to reset the command output to the spindle to 0.

- **Spindle enable signal ENB <F001#4>**

Another output related to spindle control is the spindle enable signal ENB.

The ENB signal is logical 1 when a nonzero command output is sent to the spindle. If the command is logical 0, the ENB signal becomes logical 0.

When the analog spindle is being used, an offset voltage in the spindle motor speed amplifier may cause the spindle motor to rotate at low speed even if the command output (in this case, analog voltage) to the spindle is zero. The ENB signal can be used to stop the motor in such a case.

- **Gain and offset**

The analog spindle may require gain and offset voltage adjustment depending on the spindle motor speed amplifier being used.

The following parameters are available for such adjustment.

 - Analog spindle as the first spindle
 - Gain adjustment data: Parameter No. 3730
 - Offset voltage compensation: Parameter No. 3731
 - Analog spindle as the third spindle
 - Gain adjustment data: Parameter No. 3820
(valid for multispindle control)
 - Offset voltage compensation: Parameter No. 3821

- **Electrical specification of analog spindle interface**

The signals related to analog spindle interface are described below.

The ENB1 and ENB2 signals are turned on and off under the same condition as for the ENB signal <F001#4>. They can be used also for the serial spindle.

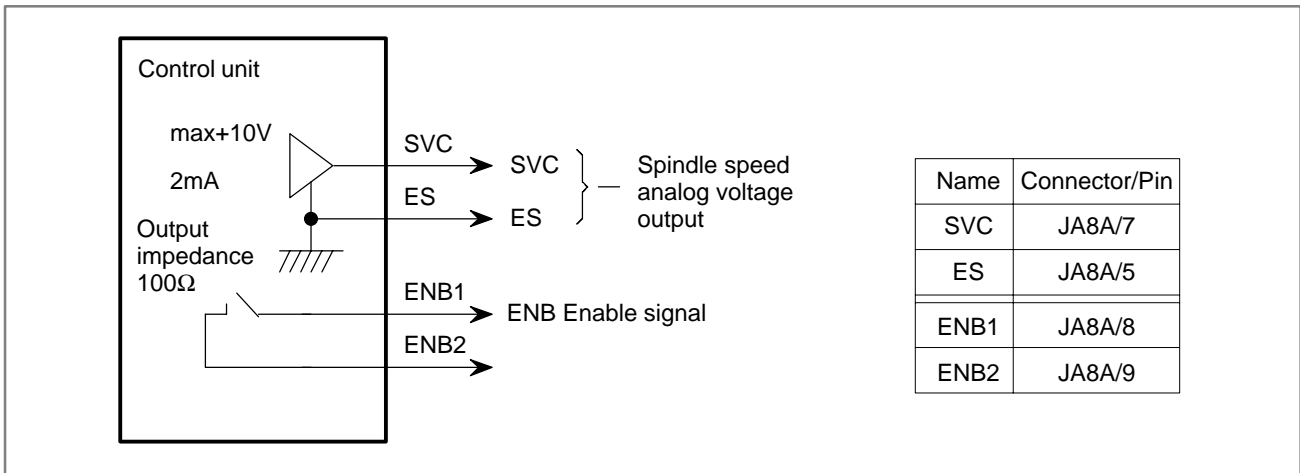

WARNING
 Since the output voltage is a weak signal, do not relay it through contacts.

● **Position coder feedback signal**

The position coder is necessary for thread cutting or feed per revolution. (For the M series, a software option must also be purchased.)

The position coder detects the actual spindle speed and the one-rotation signal (used to detect a fixed point on the spindle for thread cutting).

Ideally, the position coder should be connected directly to the spindle (with a gear ratio of 1:1). If it is necessary to use a gear, select a gear ratio from 1:1, 1:2, 1:4, and 1:8 that reduces the position coder speed.

When using a gear between the spindle and position coder, specify the gear ratio in bits 1 and 0 (PG2, PG1) of parameter No. 3706.

See Section 9.11 for position coder connection for rigid tapping.

● **Speed arrival signal (SAR)**

The spindle speed arrival signal SAR is an input signal used as a condition for the CNC to start cutting feed. This signal is used generally when cutting feed should be started after the spindle reaches the specified speed.

In this case, a sensor is used to check the spindle speed. The detected speed is sent to the CNC via the PMC.

When the above operation is performed continuously using the PC ladder, however, cutting feed may be started based on the SAR signal indicating the previous spindle state (spindle speed before change), if the spindle speed change command and the cutting feed command are issued at the same time.

To avoid the above problem, monitoring the SAR signal can be deferred for a time specified by parameter No. 3740 after the S command or cutting feed command was issued.

When using the SAR signal, set bit 0 (SAR) of parameter No. 3708 to 1.

Item No. 06 (SPINDLE SPEED ARRIVAL CHECK) on the diagnosis screen is kept at 1 while this function is keeping the cutting feed block at a halt.

Signal

Spindle stop signal

***SSTP<G029#6>**

[Classification] Input signal

[Function] The command output to the spindle is disabled.

[Operation] When the spindle stop signal turns to “0”, the output voltage becomes 0V and the enable signal ENB turns to “0” (M05 is not output). When this signal turns to “1”, the analog voltage returns to its original value and the ENB signal turns to “1”.

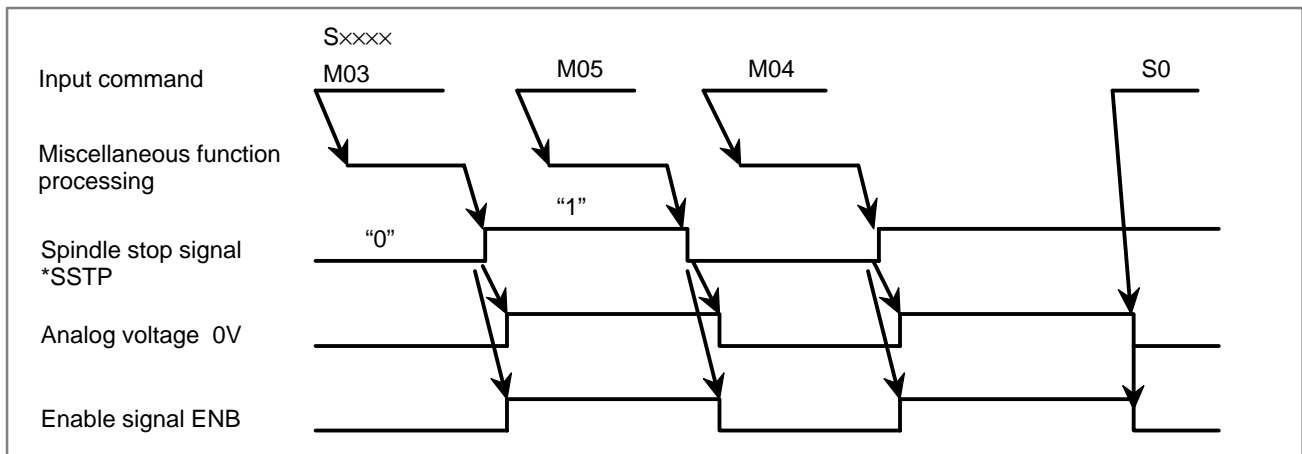

The above time chart is an example. Actually, the time chart should meet the specification of the spindle control unit.

- When this signal is not used, always set the signal to “1”.
- M03, M04, M05 are not processed inside the CNC.

Spindle orientation signal SOR <G029#5>

[Classification] Input signal

[Function] The spindle or the spindle motor is rotated at a constant speed.

[Operation] When the spindle orientation signal turns to “1” and the spindle stop signal *SSTP turns to “0”, a spindle speed command which lets the spindle rotate at the constant speed set by parameter No. 3732 is output. The enable signal ENB also turns to “1”. This signal is disabled when the spindle stop signal is “1”.

When the spindle speed for orientation is set by parameter GST No. 3705#1 and the SOR signal is input, the CNC outputs the spindle speed command corresponding to the speed set to parameter 3732 with an output polarity set by parameter ORM (No. 3706#5), but the gear select signal does not change. For example, if the SOR signal is turned to “1” with high gear selected, and the speed set to parameter No. 3732 is in the

low gear range, the gear select signal does not change and the command output is calculated and output to obtain the set speed at high gear.

When the spindle motor speed is set by parameter GST (No. 3705#1)=1, the command output is output regardless of gear select signal. When the spindle motor speed is set, it is used for gear shift.

Example of usage is shown below:

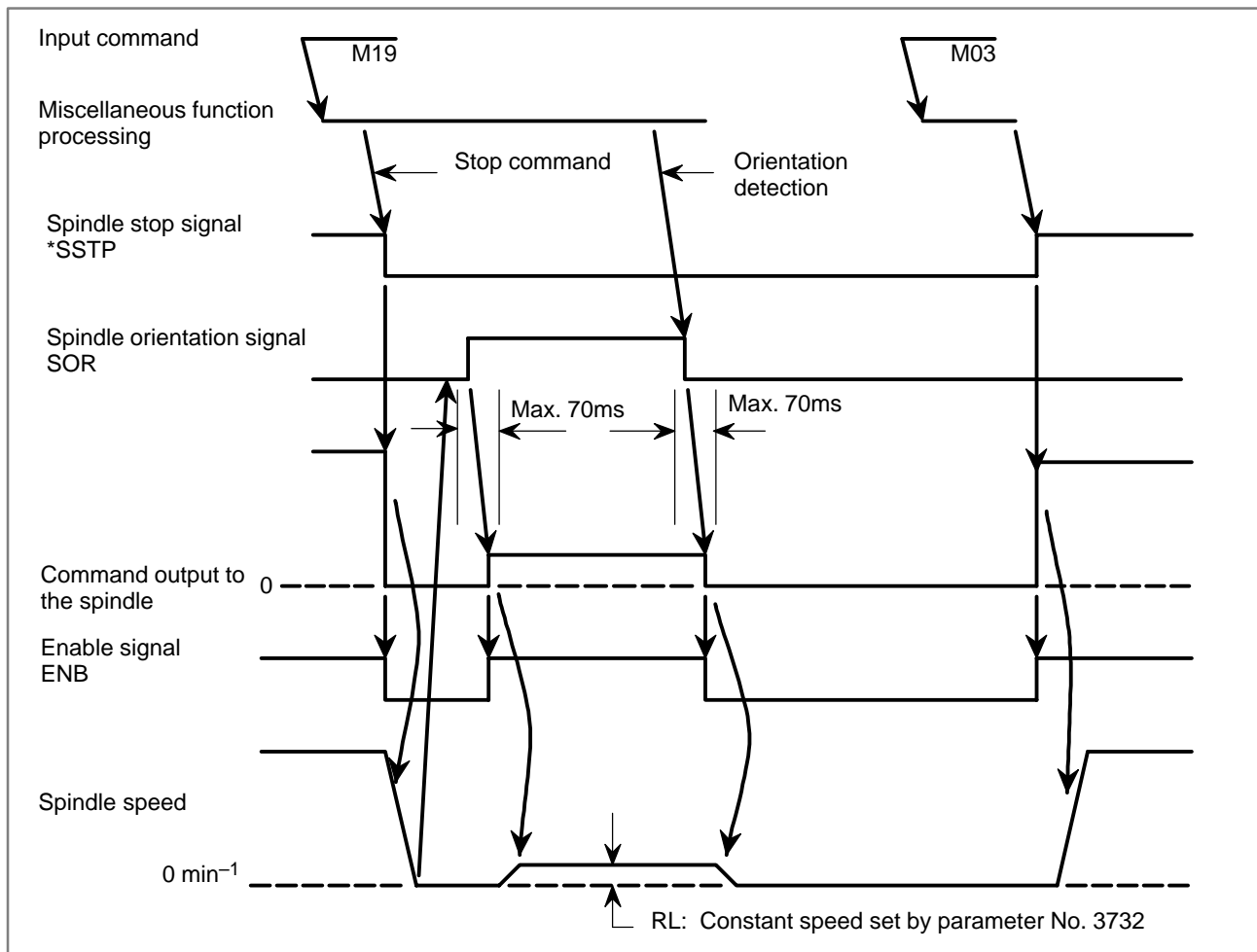

Spindle speed override signal SOV0 to SOV7

<G030>

[Classification] Input signal

[Function] The spindle speed override signal specifies an override from 0% to 254% in 1% units for the S command sent to the CNC.

[Operation] An override value in binary must be set in 8 bits from SOV7 to SOV0.

The spindle speed override function is disabled (an override of 100% is applied) under the following conditions:

- Tapping cycle (M series : G84, G74 T series : G84, G88)
- Thread cutting (M series : G33 T series : G32, G92, G76)

The spindle override can be enabled in a tapping cycle or in the thread cutting mode if TSO (bit 6 of parameter No.3798) is set accordingly. Whether the function is enabled during rigid tapping depends on the setting of the rigid tapping.

→ When this function is not in use, specify an override of 100%; otherwise, an override of 0% becomes effective, thus disabling the spindle from rotating.

Spindle speed arrival signal SAR <G029#4>

[Classification] Input signal

[Function] The SAR signal initiates cutting feed. In other words, if the signal is logical 0, cutting feed will not start.

[Operation] Generally, this signal is used to inform the CNC that the spindle has reached the specified speed.

For this purpose, the signal must be set to 1 only after the actual speed of the spindle has reached the specified speed.

Setting parameter No. 3740 with a wait time before the start of checking the SAR signal inhibits cutting feed from starting under a condition of SAR = 1 specified before the change of the spindle command.

To use the SAR signal, it is necessary to set bit 0 (SAR) of parameter No. 3708 to 1.

The CNC checks the SAR signal under the following conditions:

- a. Bit 0 (SAR) of parameter No. 3708 is set to 1.
- b. Before starting distribution of the first feed (move command) block after shifting from the rapid traverse mode to the cutting feed mode. This checking is performed after the time set by parameter No. 3740 has elapsed after the feed block is read.
- c. Before starting distribution of the first feed command block after an S code is commanded. The wait time for checking is the same as in item b.
- d. When an S code and feed are programmed in the same block, the S code (or command output to the spindle) is output, and the SAR signal is checked after a fixed time elapses. If the SAR signal is set to "1", feed begins.

CAUTION

According to the conditions of item d above, note that if the circuit is so designed that SAR is turned to "0" simultaneously with the output of an S code and the change of spindle speed is initiated by the DEN signal, the operation will stop. That is, the spindle speed does not reach the commanded speed because the CNC is waiting for the DEN signal and distribution is not started because the CNC is waiting for the SAR signal.

**Spindle enable signal
ENB <F001#4>**

[Classification] Output signal

[Function] Informs absence or presence of spindle output command.

[Output condition] The ENB signal becomes logical 0 when the command output to the spindle becomes logical 0. Otherwise, the signal is logical 1.

During analog spindle control, S0 may not be able to stop the spindle from rotating at low speed because of an offset voltage in the spindle motor speed control amplifier. In such a case, the ENB signal can be used to provide a condition to determine whether to stop the motor.

The analog spindle interface (JA40) has electric signals (ENB1 and ENB2) similar to the ENB. These signals work under the same conditions as with the ENB signal.

The ENB signal can be used also for serial spindle control.

**Gear selection signal
GR10, GR20, GR30
<F034#0 to #2>**

[Classification] Output signal

[Function] The gear select signal specifies a gear stage to the PMC.

[Output condition] For details of this signal, see descriptions on the M type gear selection method in General.

**Gear selection signal
GR1, GR2 <G028#1, #2>**

[Classification] Input signal

[Function] This signal informs the CNC of the gear stage currently selected.

[Output condition] For details of this signal, see descriptions on the T type gear selection method in General.

S12-bit code signal
R010 to R120
<F036#0 to F037#3>

[Classification] Output signal

[Function] This signal converts the spindle speed command value calculated by the CNC to code signals 0 to 4095.

[Output condition] The relationship between the spindle speed command value (calculated by the CNC) and the value output by this signal is as shown below.

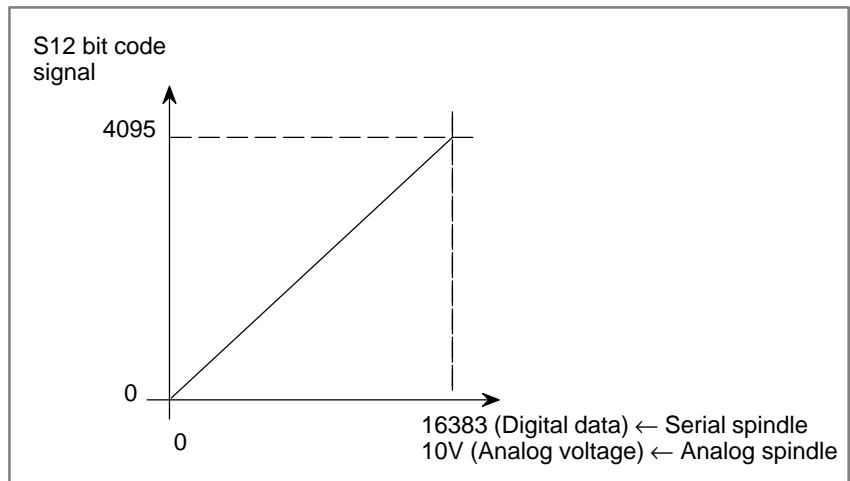

This signal converts the spindle speed command value calculated by the spindle control function of the CNC to data from 0 to 4095 (for both serial and analog spindle control) and outputs the result. Note that the conversion result is not the actual output value. (See Section 15.4.)

Other signals

Spindle speed function code signal S00 to S31 <F025 to F022> (Output)
Spindle speed function strobe signal SF<F007#2> (Output)

See Sections 9.1 and 15.4 for these signals.

Spindle speed output control signal by PMC SIND<G033#7> (Input)
R011 to R12I <G032#0 to G033#3> (Input)
SSIN <G033#6> (Input)
SGN <G033#5> (Input)

See Section 15.4 for these signals.

Signal address

	#7	#6	#5	#4	#3	#2	#1	#0
G027	CON		*SSTP3	*SSTP2	*SSTP1	SWS3	SWS2	SWS1
G028						GR2	GR1	
G029		*SSTP	SOR	SAR				
G030	SOV7	SOV6	SOV5	SOV4	SOV3	SOV2	SOV1	SOV0
G032	R08I	R07I	R06I	R05I	R04I	R03I	R02I	R01I
G033	SIND	SSIN	SGN		R12I	R11I	R10I	R09I
	#7	#6	#5	#4	#3	#2	#1	#0
F001				ENB				
F007						SF		
F022	S07	S06	S05	S04	S03	S02	S01	S00
F023	S15	S14	S13	S12	S11	S10	S09	S08
F024	S23	S22	S21	S20	S19	S18	S17	S16
F025	S31	S30	S29	S28	S27	S26	S25	S24
F034						GR30	GR20	GR10
F036	R08O	R07O	R06O	R05O	R04O	R03O	R02O	R01O
F037					R12O	R11O	R10O	R09O

Parameter

	#7	#6	#5	#4	#3	#2	#1	#0
3705				EVS				ESF
		SFA	NSF		SGT	SGB	GST	ESF

[Data type] Bit

ESF When the spindle control function (S analog output or S serial output) is used, and the constant surface speed control function is used or bit 4 (GTT) of parameter No. 3706 is set to 1:

0 : S codes and SF are output for all S commands.

1 : S codes and SF are not output for an S command in constant surface speed control mode (G96 mode) or for an S command used to specify maximum spindle speed clamping (G50S—;).

NOTE

For the T series, this parameter is enabled when bit 4 (EVS) of parameter No. 3705 is set to 1.

For the M series, SF is not output:

(1) For an S command used to specify maximum spindle speed clamping (G92S—;) in constant surface speed control mode

(2) When bit 5 (NSF) of parameter No. 3705 is set to 1

GST: The SOR signal is used for:

- 0 : Spindle orientation
- 1 : Gear shift

SGB: Gear switching method

- 0 : Method A (Parameters No. 3741 to 3743 for the maximum spindle speed at each gear are used for gear selection.)
- 1 : Method B (Parameters No. 3751 and 3752 for the spindle speed at the gear switching point are used for gear selection.)

SGT: Gear switching method during tapping cycle (G84 and G74)

- 0 : Method A (Same as the normal gear switching method)
- 1 : Method B (Gears are switched during tapping cycle according to the spindle speed set in parameters No. 3761 and 3762).

EVS When the spindle control function (S analog output or S serial output) is used, S codes and SF are:

- 0 : Not output for an S command.
- 1 : Output for an S command.

NOTE

The output of S codes and SF for an S command in constant surface speed control mode (G96), or for an S command used to specify maximum spindle speed clamping (G50S—;) depends on the setting of bit 0 (ESF) of parameter No. 3705.

NSF: When an S code command is issued in constant surface speed control,

- 0 : SF is output.
- 1 : SF is not output.

SFA: The SF signal is output:

- 0 : When gears are switched
- 1 : Irrespective of whether gears are switched

	#7	#6	#5	#4	#3	#2	#1	#0
3706	TCW	CWM	ORM				PG2	PG1
	TCW	CWM	ORM	GTT			PG2	PG1

[Data type] Bit

PG2, PG1 Gear ratio of spindle to position coder

Magnification	PG2	PG1
×1	0	0
×2	0	1
×4	1	0
×8	1	1

$$\text{Magnification} = \frac{\text{Number of spindle revolutions}}{\text{Number of position coder revolutions}}$$

GTT Selection of a spindle gear selection method

- 0 : Type M
- 1 : Type T

NOTE

1 Type M:

The gear selection signal is not entered externally. In response to an S command, the CNC selects a gear according to the speed range for each gear specified in parameters. Then the CNC reports the selection of a gear by outputting the gear selection signal. The spindle speed corresponding to the gear selected by the gear selection signal is output.

Type T:

The gear selection signal is entered from the PMC. The spindle speed corresponding to the gear selected by this signal is output.

2 When the constant surface speed control option is selected, type T is selected, regardless of whether this parameter is specified.

3 When type T spindle gear switching is selected, the following parameters have no effect:
 No. 3705#2 SGB, No. 3751, No. 3752, No. 3705#3 SGT, No. 3761, No. 3762, No. 3705#6 SFA, No. 3735, No. 3736
 However, parameter No. 3744 is valid.

ORM Voltage polarity during spindle orientation

- 0 : Positive
- 1 : Negative

TCW, CWM Voltage polarity when the spindle speed voltage is output

TCW	CWM	Voltage polarity
0	0	Both M03 and M04 positive
0	1	Both M03 and M04 negative
1	0	M03 positive, M04 negative
1	1	M03 negative, M04 positive

	#7	#6	#5	#4	#3	#2	#1	#0
3708		TSO						

[Data type] Bit

TSO During a threading or tapping cycle, the spindle override is:

- 0 : Disabled (tied to 100%).
- 1 : Enabled.

NOTE

The operation during rigid tapping depends not only on this parameter but on the setting of rigid tapping.

	#7	#6	#5	#4	#3	#2	#1	#0
3709								SAM

[Data type] Bit

SAM The sampling frequency to obtain the average spindle speed
 0 : 4 (Normally, set to 0.)
 1 : 1

3730	Data used for adjusting the gain of the analog output of spindle speed
------	--

[Data type] Word

[Unit of data] 0.1 %

[Valid data range] 700 to 1250

Set data used for adjusting the gain of the analog output of spindle speed.

- [Adjustment method]** (1) Assign standard value 1000 to the parameter.
 (2) Command the maximum spindle speed.
 (3) Measure the output voltage.
 (4) Assign the value obtained by the following equation to parameter No. 3730.

$$\text{Set value} = \frac{10 \text{ (V)}}{\text{Measured data (V)}} \times 1000$$

- (5) After setting the parameters, command the maximum spindle speed, confirm that the output is 10V.

NOTE

This parameter needs not to be set for serial spindles.

3731	Compensation value for the offset voltage of the analog output of the spindle speed
------	---

[Data type] Word

[Unit of data] Velo

[Valid data range] -1024 to +1024

Set compensation value for the offset voltage of the analog output of the spindle speed.

$$\text{Set value} = -8191 \times \text{Offset voltage (V)} / 12.5$$

- [Adjustment method]** (1) Assign standard value 0 to the parameter.
 (2) Command “0”.
 (3) Measure the output voltage.
 (4) Assign the value obtained by the following equation to parameter No. 3731.

$$\text{Set value} = \frac{-8191 \times \text{Offset voltage (V)}}{12.5}$$

(5) After setting the parameters, command “0”, confirm that the output is 0V.

NOTE

This parameter need not to be set for serial spindles.

3732

The spindle speed during spindle orientation or the spindle motor speed during spindle gear shift

[Data type] Two-word

[Valid data range] 0 to 20000

Set the spindle speed during spindle orientation or the spindle motor speed during gear shift.

When GST, #1 of parameter 3705, is set to 0, this is the spindle speed during spindle orientation in min^{-1} .

When GST, #1 of parameter 3705, is set to 1, this is the spindle motor speed during spindle gear shift calculated from the following formula.

$$\text{Set value} = \frac{\text{Spindle motor speed during spindle gear shift}}{\text{Maximum spindle motor speed}} \times 16383 \quad (\text{For a serial spindle})$$

$$\text{Set value} = \frac{\text{Spindle motor speed during spindle gear shift}}{\text{Maximum spindle motor speed}} \times 4095 \quad (\text{For an analog spindle})$$

3735

Minimum clamp speed of the spindle motor

[Data type] Word

[Valid data range] 0 to 4095

Set the minimum clamp speed of the spindle motor.

$$\text{Set value} = \frac{\text{Minimum clamp speed of the spindle motor}}{\text{Maximum spindle motor speed}} \times 4095$$

NOTE

If the function of constant surface speed control or bit 4 (GTT) of parameter No. 3706 is specified, this parameter is invalid.

3736

Maximum clamp speed of the spindle motor

[Data type] Word

[Valid data range] 0 to 4095

Set the maximum clamp speed of the spindle motor.

$$\text{Set value} = \frac{\text{Maximum clamp speed of the spindle motor}}{\text{Maximum spindle motor speed}} \times 4095$$

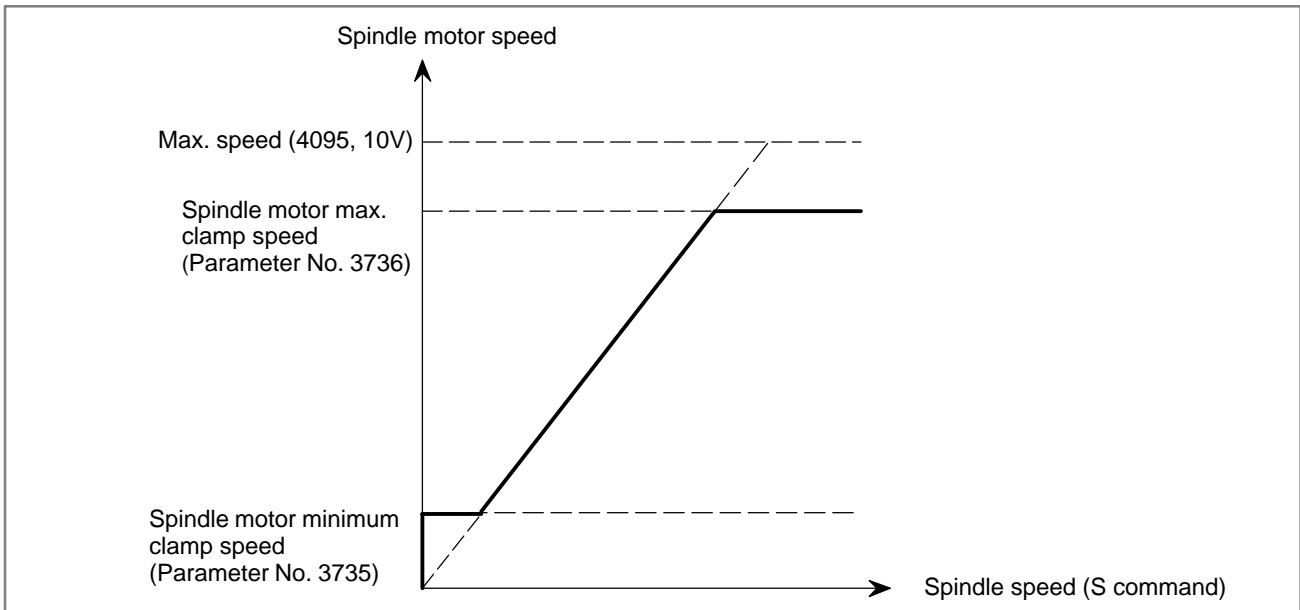

NOTE

If the function of constant surface speed control or bit 4 (GTT) of parameter No. 3706 is specified, this parameter is invalid.

In this case, the maximum clamp speed of spindle motor cannot be specified. However, the maximum spindle speed can be specified by the following parameters.

Parameter No.3772 (for the first axis)

Parameter No.3802 (for the second axis)

Parameter No.3822 (for the third axis)

Parameter No.3850 (for the fourth axis)

3740	Time elapsed prior to checking the spindle speed arrival signal
------	---

[Data type] Byte

[Unit of data] msec

[Valid data range] 0 to 225

Set the time elapsed from the execution of the S function up to the checking of the spindle speed arrival signal.

3741	Maximum spindle speed for gear 1
3742	Maximum spindle speed for gear 2
3743	Maximum spindle speed for gear 3
3744	Maximum spindle speed for gear 4

[Data type] Word

[Unit of data] min⁻¹

[Valid data range] 0 to 32767

Set the maximum spindle speed corresponding to each gear.

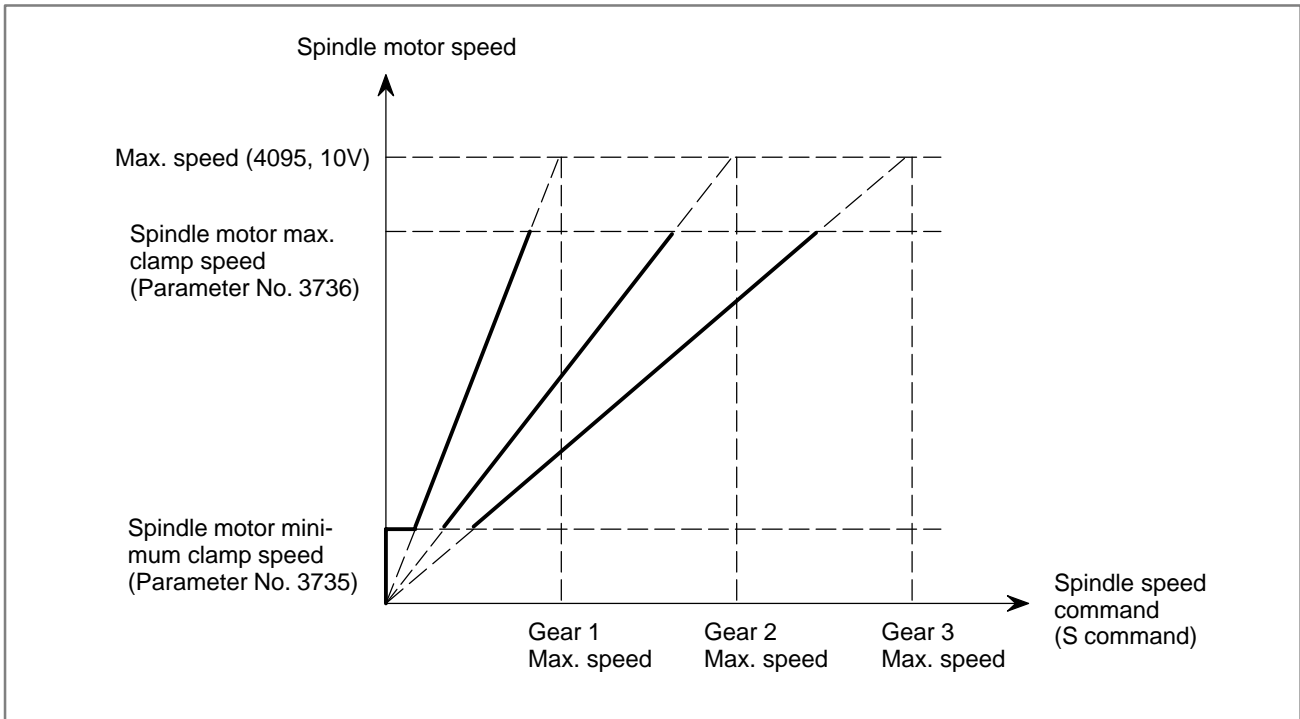

3751	Spindle motor speed when switching from gear 1 to gear 2
3752	Spindle motor speed when switching from gear 2 to gear 3

[Data type] Word

[Valid data range] 0 to 4095

For gear switching method B, set the spindle motor speed when the gears are switched.

$$\text{Set value} = \frac{\text{Spindle motor speed when the gears are switched}}{\text{Maximum spindle motor speed}} \times 4095$$

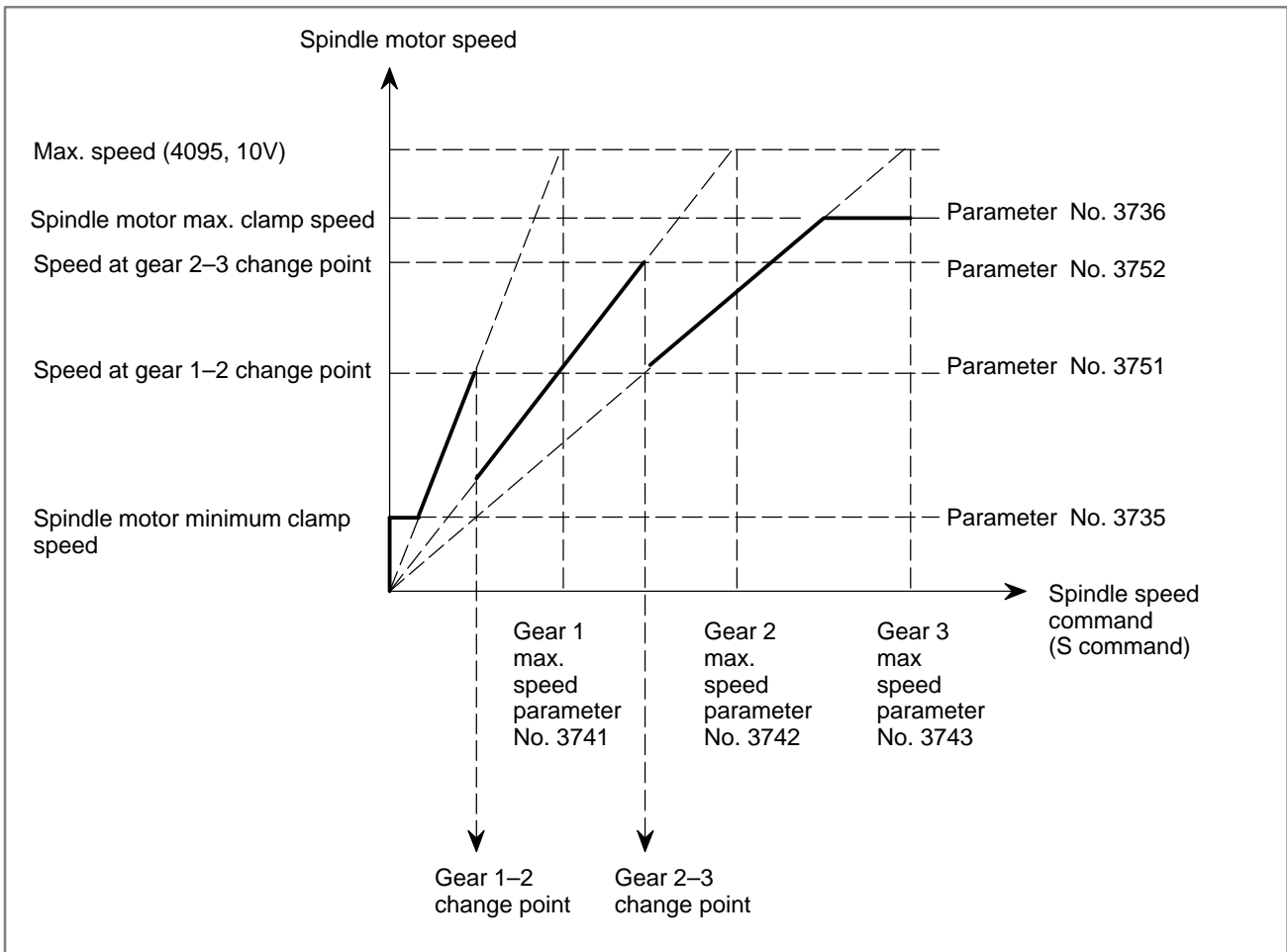

3761	Spindle speed when switching from gear 1 to gear 2 during tapping
3762	Spindle speed when switching from gear 2 to gear 3 during tapping

[Data type] Word

[Unit of data] min^{-1}

[Valid data range] 0 to 32767

When method B is selected (SGT,#3 of parameter 3705, is set to 1) for the tapping cycle gear switching method, set the spindle speed when the gears are switched.

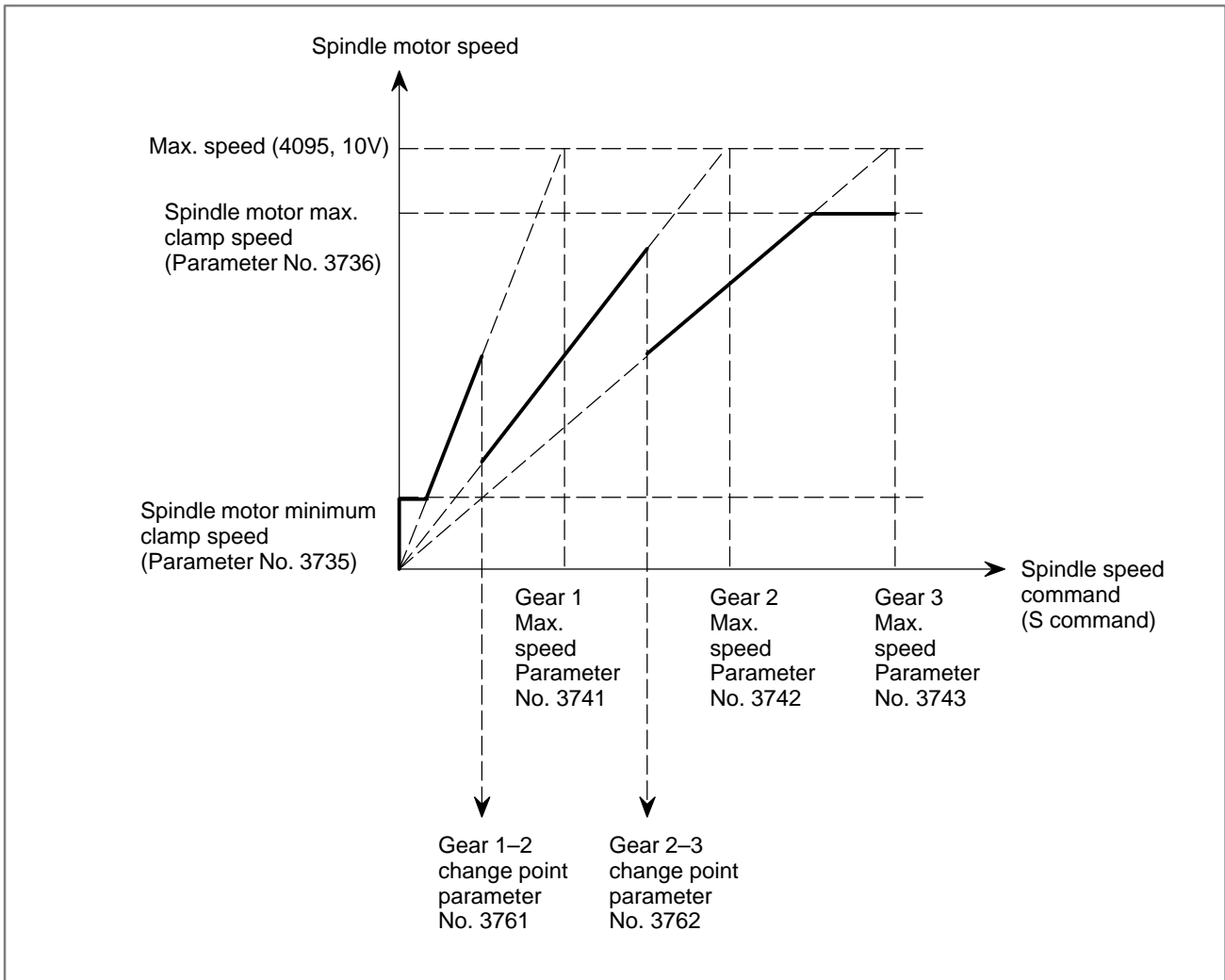

3772	Maximum spindle speed
------	-----------------------

[Data type] Word

[Unit of data] min⁻¹

[Valid data range] 0 to 32767

This parameter sets the maximum spindle speed.

When a command specifying a speed exceeding the maximum speed of the spindle is specified, or the speed of the spindle exceeds the maximum speed because of the spindle speed override function, the spindle speed is clamped at the maximum speed set in the parameter.

WARNING

- 1 When 0 is set in this parameter, the speed of the spindle is not clamped.
- 2 When spindle speed command control is applied using the PMC, this parameter has no effect, and the spindle speed is not clamped.

NOTE

- 1 In the M series, this parameter is valid only when the constant surface speed control option is present.
- 2 When the constant surface speed control option is present, the spindle speed is clamped at the maximum speed, regardless of whether the G96 mode or G97 mode is specified.
- 3 When the multi-spindle control option is present, set the maximum speed for each spindle in the following parameters:
 Parameter No. 3772: Sets the maximum speed for the first spindle.
 Parameter No. 3802: Sets the maximum speed for the second spindle.
 Parameter No. 3822: Sets the maximum speed for the third spindle.

3821	Offset-voltage compensation value of the analog output of the third-spindle speed
------	---

[Data type] Word

[Unit of data] Velo

[Valid data range] -1024 to 1024

Set the offset-voltage compensation value of the analog output of the third-spindle speed.

Caution**CAUTION**

This section mentioned a spindle speed control that should be prepared on the CNC side. But it is also necessary to design the signals to the spindle control unit. Consult the manual of the spindle control unit used and take necessary actions on the spindle control unit.

9.4 SPINDLE SPEED CONTROL FOR TWO-PATH LATHE

General

In a two-path lathe application, the additional path section (path No. 2) can have the same spindle interface as a one-path lathe (see Section 9.2.).

Each spindle is controlled by a command issued by tool post 1 or 2. Which spindle is controlled by which tool post can be switched by signals.

This section describes the configuration of a two-path lathe application and how it is controlled.

In the following description, the term tool post 1 refers to path No. 1, and the term tool post 2 refers to path No. 2.

One-spindle control and two-spindle control

In a two-path lathe application, there are two selectable configurations, a configuration in which the entire system uses one spindle (one-spindle control) and a configuration in which each spindle is controlled separately (two-spindle control). Parameter No. 3703#0 (2SP) is used to select a configuration.

One-spindle control

The spindle interface for tool post 2 is not used.

- Selection of the spindle command
- Position coder feedback signal (serial spindle)

The spindle command select signal SLSPA<G063#2> (input) specifies the tool post whose spindle command is to be followed by the spindle.

When a serial spindle is used, the position coder feedback signal is supplied to both paths in the NC. Either tool post can be used for thread cutting and feed per rotation.

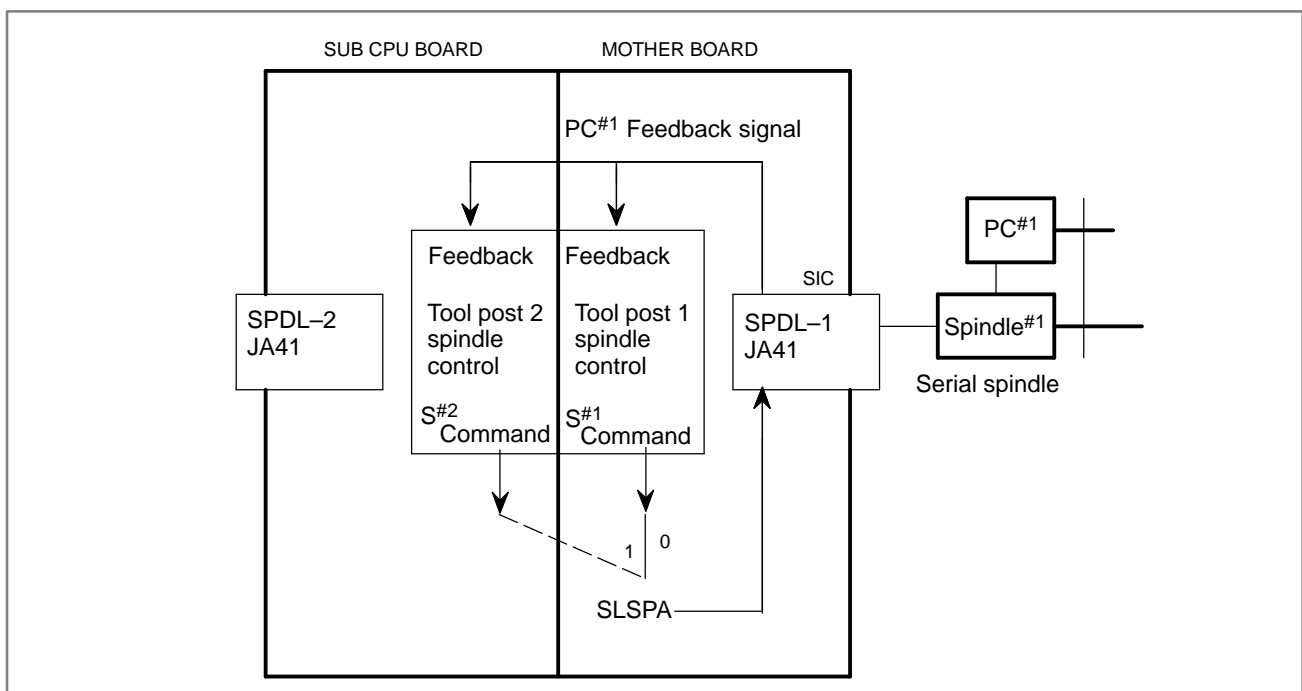

Fig. 9.4 (a) One spindle control (serial spindle)

● **Position coder feedback signal (Analog)**

When an analog spindle is used, supplying the position coder feedback signal to the position coder interface of tool post 2 via an external distribution circuit makes it possible to use either tool post for thread cutting and feed per rotation.

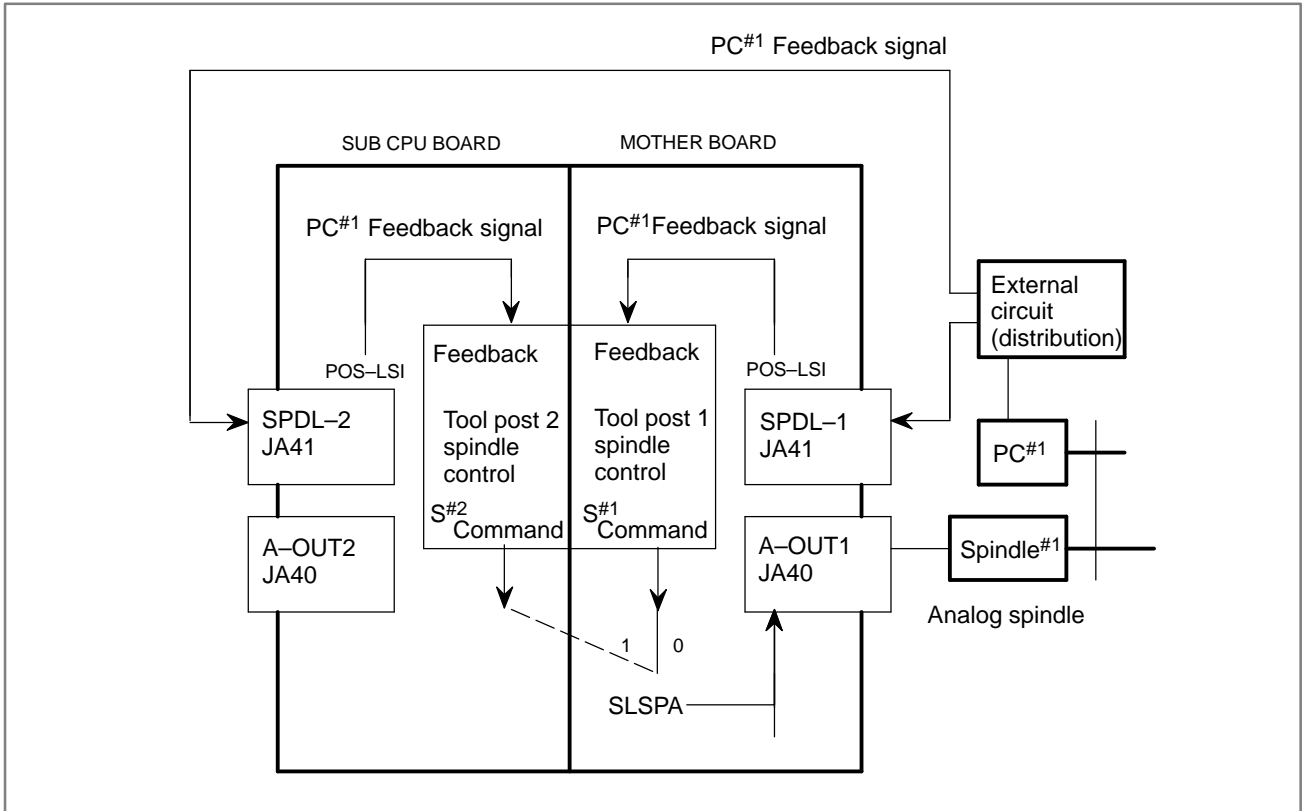

Fig. 9.4 (b) One spindle control (analog spindle)

Two-spindle control

● **Selection of spindle command**

The spindle interfaces for both tool posts are used.

The spindle command select signals SLSPA <G063#2> and SLSPB <G063#3> (input) specify the tool post whose spindle command is to be followed by each spindle.

● **Position coder feedback signal (When both are serial spindle)**

When the serial spindles are used on both tool posts, the position coder feedback signals SLPCA<G064#2> and SLPCB<G064#3> (input) direct each tool post to select which spindle's position coder feedback signal is used. Therefore, it is possible to use the spindle of the other system; for example, tool post 1 can perform thread cutting or feed per rotation using the spindle connected to tool post 2.

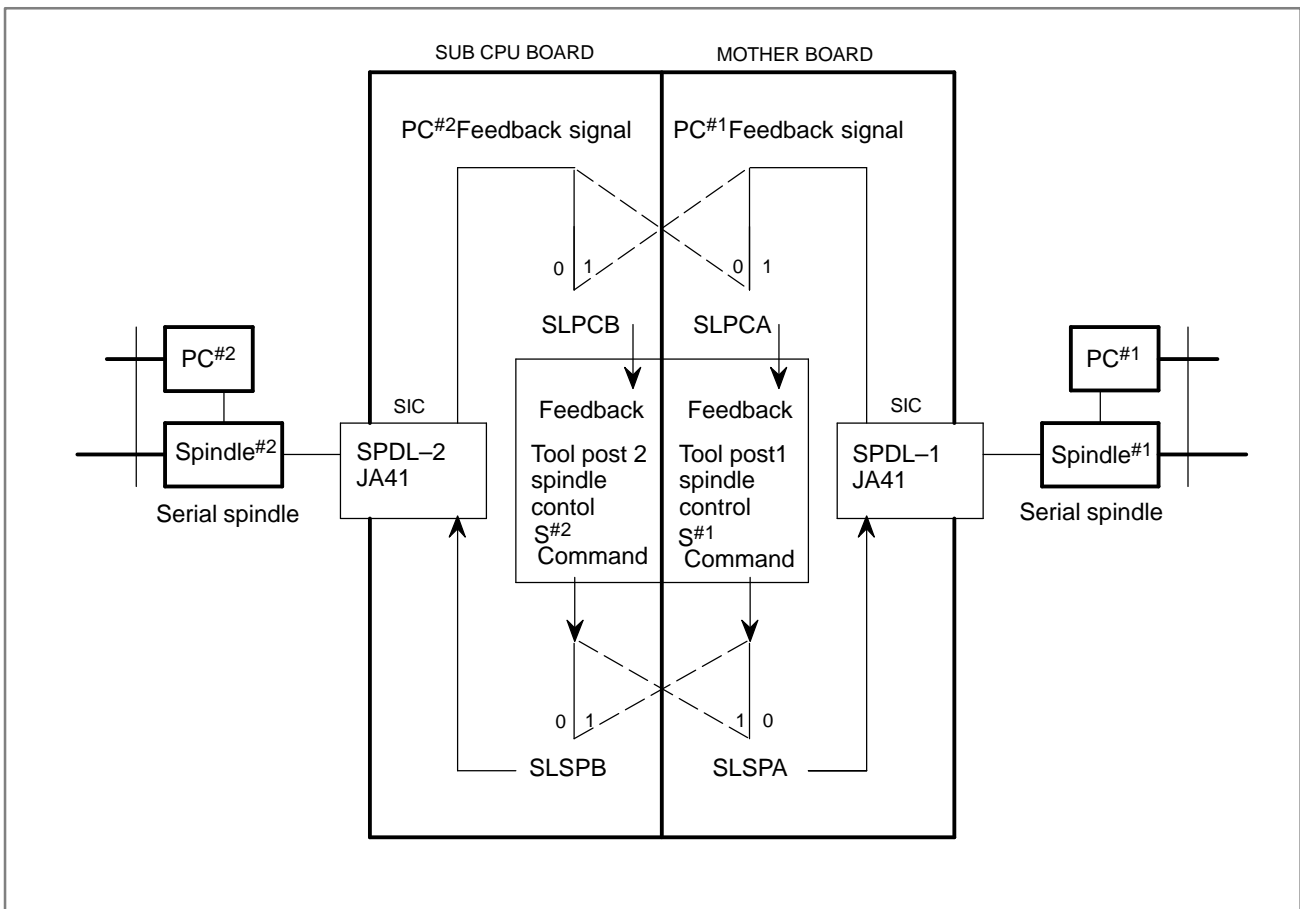

Fig. 9.4 (c) Two-spindle control (serial spindle)

● **Position coder feedback signal (when an analog spindle is used)**

If either tool post uses an analog spindle as the first spindle, the spindle feedback signals SLPCA<G064#2> and SLPCB<G064#3> (input) cannot cause the NC to select a position coder feedback signal.

If both tool posts use an analog spindle, switching the position coder feedback signal inputs to the NC using an external circuit makes it possible to use the spindle of the other system.

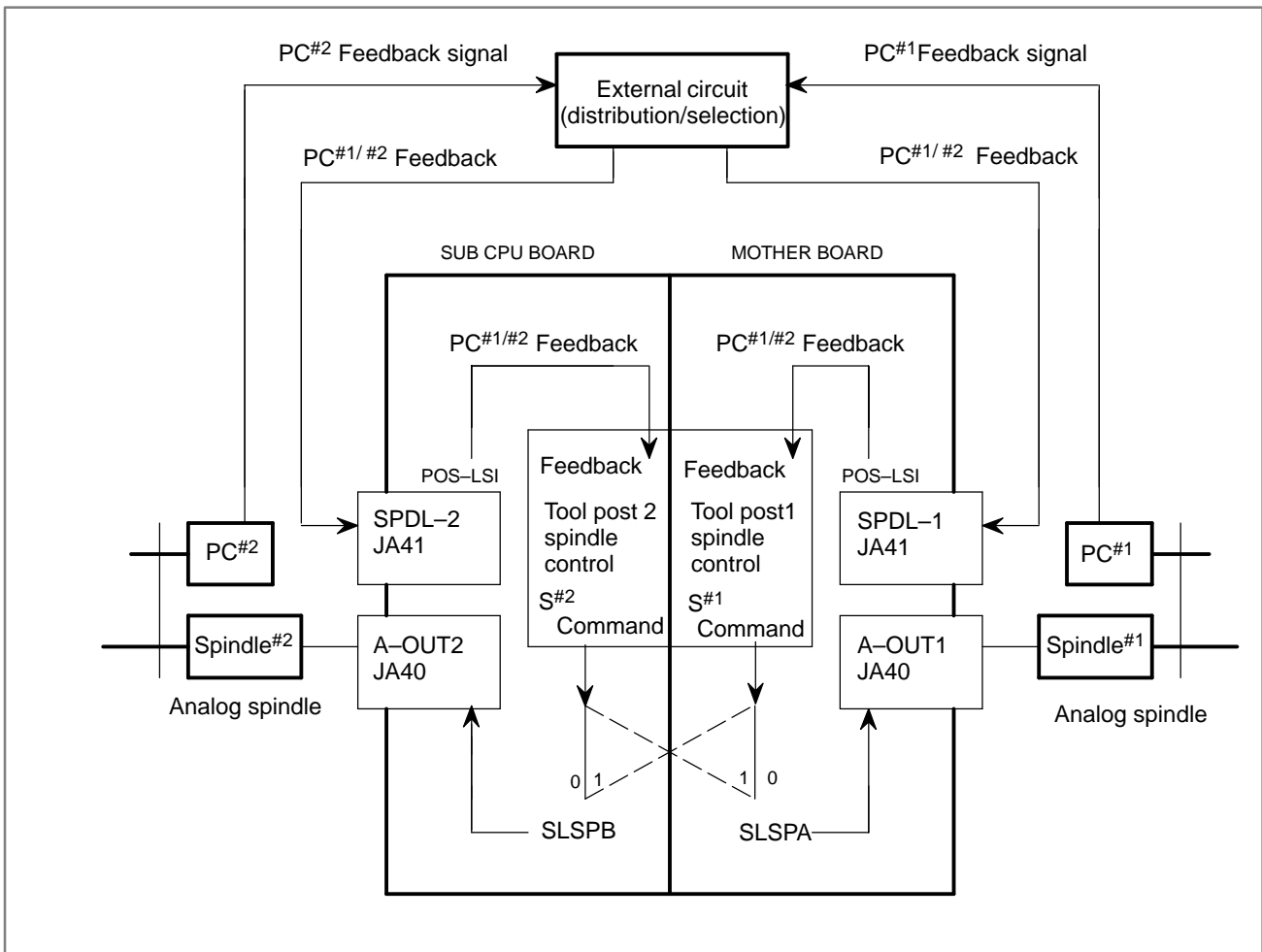

Fig. 9.4 (d) Two-spindle control (analog spindle)

2nd and 3rd spindles

If the first spindle is a serial spindle, the second and third spindles can also be used in a two-path lathe application. (See Section 9.2.)

In the following chart, all spindles are connected under two-spindle control.

Under one-spindle control, no spindle (SP1#2, SP2#2, SP3#2) of tool post 2 may be used.

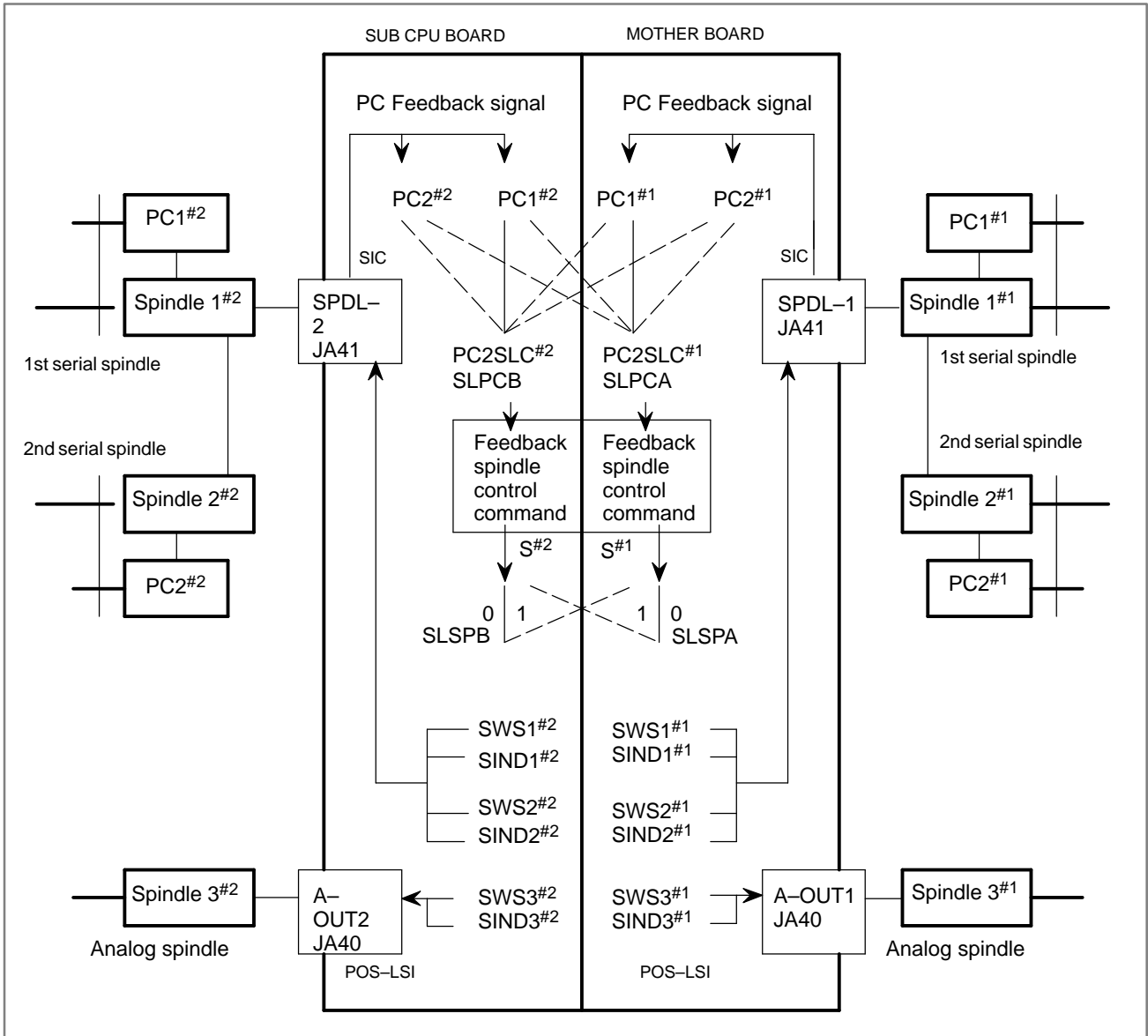

Fig. 9.4 (e) Spindle configuration and flow of commands and feedback signals in an two-path lathe application (with all spindles under two-spindle control)

The second and third spindles should be controlled using the PMC or be under multi-spindle control. (See Section 15.4 or 9.10.)

If multi-spindle control is applied to both tool posts, the position coder feedback signal for the second spindle of each tool post becomes usable.

See descriptions of bit 3 (PCS) of parameter No. 3706.

Options related to spindles

Optional functions for spindles are valid for both tool posts. However, you may want to use the optional functions for only one of the tool posts because of relationships with the interface and PMC ladder.

Parameters are available to disable the following functions for individual tool posts.

- Spindle serial output
- Spindle analog output
- Cs contour control
- Spindle positioning
- Multi-spindle control

Refer to parameter No. 3702.

Signal

Spindle command select signals

SLSPA <G063#2>,
SLSPB <G063#3>

[Classification] Input signal

[Function] Selects each tool post's spindle receives spindle command of which tool posts.

SLSPA: Selects which spindle command is sent to the spindle connected to tool post 1.

SLSPB: Selects which spindle command is sent to the spindle connected to tool post 2.

The spindle command select signals are associated with the spindle commands as follows:

(1) In the 1-spindle control mode

Signal input SLSPA	Command to spindle
0	Spindle command of tool post 1
1	Spindle command of tool post 2

NOTE

SLSPB is ineffective in 1 spindle control mode.

(2) In the 2-spindle control mode

Signal input		Command to the spindle connected to tool post 1	Command to the spindle connected to tool post 2
SLSPA	SLSPB		
0	0	Spindle command of tool post 1	Spindle command of tool post 2
0	1	Spindle command of tool post 1	Spindle command of tool post 1
1	0	Spindle command of tool post 2	Spindle command of tool post 2
1	1	Spindle command of tool post 2	Spindle command of tool post 1

Spindle feedback select signals

SLPCA <G064#2>

SLPCB <G064#3>

[Classification] Input signal

[Function] Selects which spindle sends position coder feedback to which tool post.

NOTE

This function is effective only in the 2-spindle control system in which both tool posts use serial spindle.

SLPCA: Selects the feedback signal for tool post 1.

SLPCB: Selects the feedback signal for tool post 2.

The spindle feedback select signals are associated with the feedback signals of the position coder as follows:

(1) In 1-spindle control mode

The feedback signal of the spindle connected to tool post 1 is always sent to both tool posts; the SLPCA and SLPCB signals have no meaning.

(2) In 2-spindle control mode

Signal input		Tool post 1	Tool post 2
SLPCA	SLPCB		
0	0	PC#1	PC#2
0	1	PC#1	PC#1
1	0	PC#2	PC#2
1	1	PC#2	PC#1

PC#1=Position coder feedback signal with the spindle connected to tool post 1.

PC#2=Position coder feedback signal with the spindle connected to tool post 2.

NOTE

The SLPCA and SLPCB signals are effective only in the 2-spindle control mode using two serial spindles. In the 2-spindle control mode using analog spindles, the feedback signal of spindle 1 is input to tool post 1, and the feedback signal of spindle 2 is input to tool post 2, regardless of the setting of the SLPCA and SLPCB signals.

**Spindle command signal
COSP <F064#5>**

[Classification] Output signal

[Function] Indicates which tool post issued the latest spindle command.

[Output condition] The COSP signal turns to “1” when:

- Tool post 2 issues the spindle command.

The COSP signal turns to “0” when:

- Tool post 1 issues the spindle command, or neither of the tool posts issues the spindle command.

[Use] In 1-spindle control mode, if this signal is input to the SLSPA signal (spindle command select signal), the spindle speed specified by the latest spindle command can always be output to the spindle, regardless of whether it is from tool post 1 or 2.

Signal address

	#7	#6	#5	#4	#3	#2	#1	#0
G063					SLSPB	SLSPA		
G064					SLPCB	SLPCA		
	#7	#6	#5	#4	#3	#2	#1	#0
F064			COSP					

Parameter

	#7	#6	#5	#4	#3	#2	#1	#0
3702	ECS	ESS	EAS	ESI			EMS	

[Data type] Bit**EMS** Multi-spindle control function

0 : Used

1 : Not used

NOTE

If the multi-spindle control function is not required for one tool post in two-path control, specify this parameter for the tool post to which the multi-spindle control function need not be applied.

ESI The spindle positioning function is

0 : Used

1 : Not used

NOTE

This parameter is used when the spindle positioning option specified with two-path control, and the spindle positioning function is not required for either path. Set ESI to 1 for a system that does not require the spindle positioning function.

EAS For tool post 1 (or tool post 2), the S analog output function is:

0 : Used.

1 : Not used.

ESS For tool post 1 (or tool post 2), the S serial output function is:

0 : Used.

1 : Not used.

ECS For tool post 1 (or tool post 2), the Cs contour control function is:

0 : Used.

1 : Not used.

NOTE

Parameter EAS, ESS, and ECS are used for T series 2-path control.

These parameters are used to determine whether the optional function, S analog output function, S serial output function, and Cs contour control function, are used for each tool post.

3703	#7	#6	#5	#4	#3	#2	#1	#0
								2SP

[Data type] Bit

2SP Specifies whether one or two spindles are controlled (at 2-path control).

0 : One spindle (two tool posts)

1 : Two spindle (two tool posts)

3706	#7	#6	#5	#4	#3	#2	#1	#0
					PCS			

[Data type] Bit

PCS When multi-spindle control is applied to two tool posts in two-path control, this parameter specifies whether a position coder feedback signal from the other tool post is selectable, regardless of the state of the PC2SLC signal (bit 7 of G028/bit 7 of G1028) of the other tool post:

0 : Not selectable.

1 : Selectable. (To select a position coder for the other tool post, the SLPCA signal (bit 2 of G064) and the SLPCB signal (bit 3 of G064) are used.)

NOTE

Multi-spindle control based on the same serial spindle must be applied to both tool posts.

- Selecting position coder feedback signals for both tool posts in a two-path lathe application under multi-spindle control.

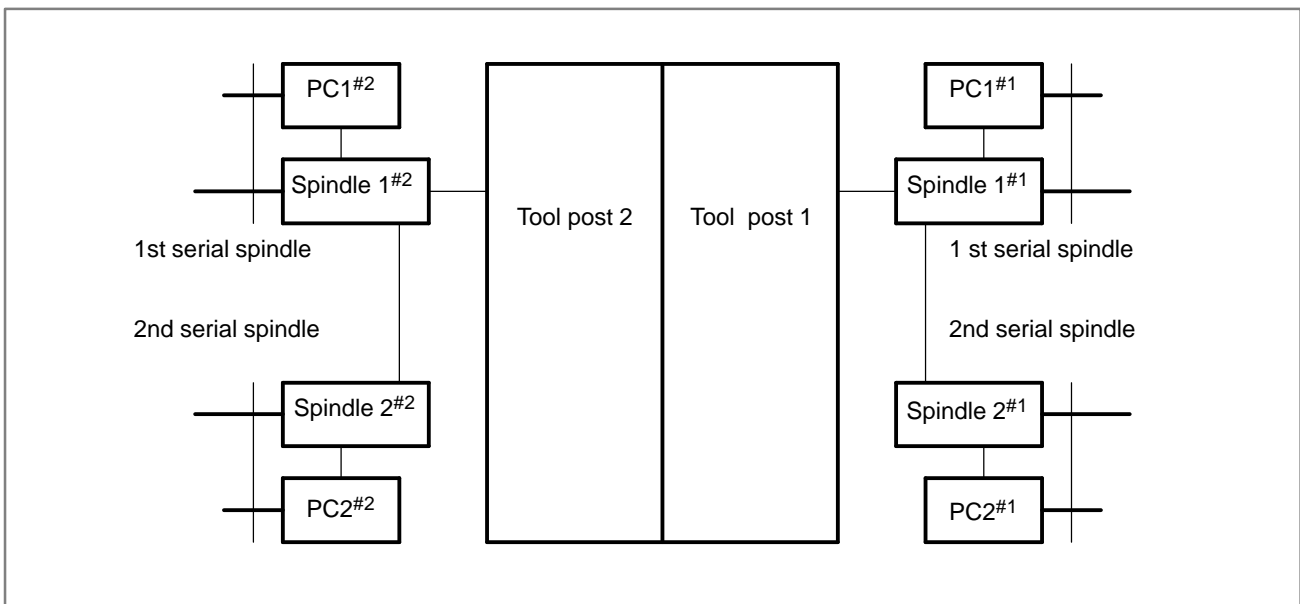

Table 9.4 lists the position coder feedback signals used for each tool post in the above configuration. These position coder feedback signals are selected according to the following:

- Bit 3 (PCS) of parameter No. 3706
- Spindle feedback select signals SLPCA <G064#2> and SLPCB <G064#3>
- Multi-spindle control
Second position coder select signals PC2SLC#1 <G028#7> and PC2SLC#2 <G1028#7>

Table 9.4 Selection of position coder feedback signal in two-path lathe
(— means position coder selection is indifferent on the tool post side)

When parameter No. 3706#3=1

	Position coder select	SLPCA	SLPCB	PC2SLC#1	PC2SLC#2
Tool post 1	PC1#1	"0"	—	"0"	—
	PC2#1	"0"	—	"1"	—
	PC1#2	"1"	—	"0"	—
	PC2#2	"1"	—	"1"	—
Tool post 2	PC1#1	—	"1"	—	"0"
	PC2#1	—	"1"	—	"1"
	PC1#2	—	"0"	—	"0"
	PC2#2	—	"0"	—	"1"

When parameter No. 3706#3=0

	Position coder select	SLPCA	SLPCB	PC2SLC#1	PC2SLC#2
Tool post 1	PC1#1	"0"	—	"0"	—
	PC2#1	"0"	—	"1"	—
	PC1#2	"1"	—	—	"0"
	PC2#2	"1"	—	—	"1"
Tool post 2	PC1#1	—	"1"	"0"	—
	PC2#1	—	"1"	"1"	—
	PC1#2	—	"0"	—	"0"
	PC2#2	—	"0"	—	"1"

Note**NOTE**

- 1 The spindle commands include S code commands, maximum speed command (G50S__), M03, M04, M05, and constant surface speed control commands (G96 and G97)
- 2 Signals to operate the spindle control unit are not affected by the spindle command select signals SLSPA<G063#2> or SLSPB<G063#3>. They may be processed in the PMC ladder, as required.
(Example: SFRA <G070#5> is always a forward rotation command for the first spindle control amplifier of tool post 1.)
- 3 The machine tool builder should prepare an external circuit to distribute and select position coder feedback signals for the analog spindle.

9.5 CONSTANT SURFACE SPEED CONTROL

General

With the spindle serial output or analog output function, specifying the surface speed (m/min or feet/min) directly in an S command makes it possible to change the spindle output continuously so as to maintain a constant surface speed at a programmed point. (For the rapid traverse command, however, the surface speed for the end point is output at the beginning of rapid traverse.)

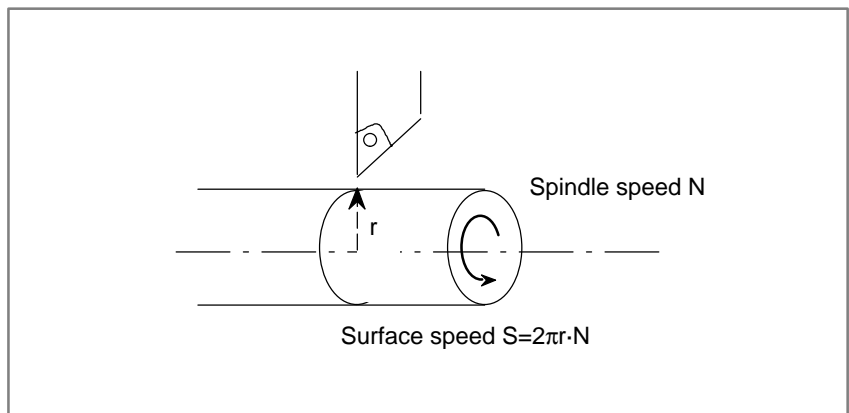

Whether or not constant surface speed control is performed is selected by G code.

G96: Constant surface speed control performed. S in the G96 mode is m/min or feet/min.

G97: Constant surface speed control not performed. S in the G97 mode is rev/min.

To perform constant surface speed control, the maximum spindle speed for each gear select signal issued from the PMC side must be set by parameter No. 3741-3744.

The gear select signal is a 2 bit code signal (GR1, GR2). The relationship between the signal and gear number is :

GR1	GR2	Gear number
0	0	1
1	0	2
0	1	3
1	1	4

Example of Spindle Analog Output

Assume that gear switching is two stage switching. If the spindle speed with the output 10 V is 1000 min⁻¹ for the low speed gear (G1) and 2000 min⁻¹ for the high speed gear (G2), set these speeds to the parameter No. 3741, 3742, respectively. In this case, the spindle output has the linear relationship shown below:

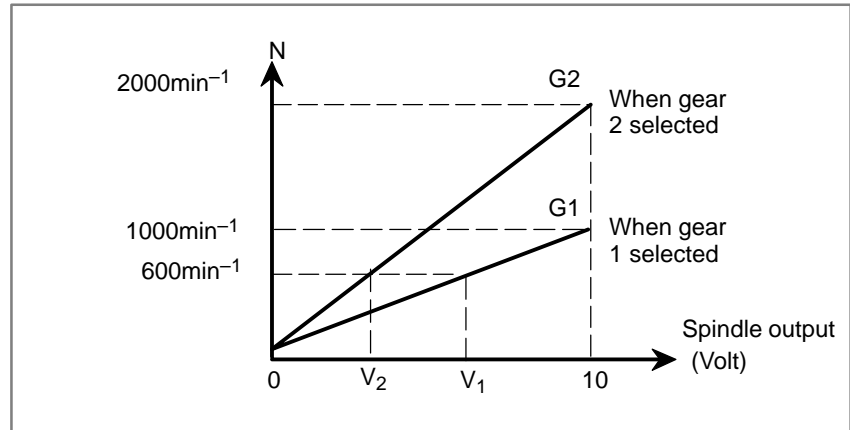

Here, $S = 60$ m/min is given as the surface speed; if the position of the present X-axis cutter is 16 mm from the center, the spindle speed N becomes 600 min⁻¹ ($S = 2\pi r N$). Therefore, V_1 (for G1) or V_2 (for G2) is calculated inside the CNC and output to the machine side.

$$V_1: 6(\text{V})$$

$$V_2: 3(\text{V})$$

The value of output voltage V is calculated automatically from the following equations:

(i) G96

$$V = \frac{10S}{2\pi r R}$$

R: Spindle speed (min⁻¹) at 10V output voltage (that is, spindle speed set by parameter No. 3741 to No. 3744)

S: Surface speed (m/min) specified by S command

r: Radius value in the X-axis direction (m)

(ii) G97

$$V = \frac{10N}{R}$$

R: Spindle speed at 10V output voltage (min⁻¹)

N: Spindle speed given by S command (min⁻¹)

Spindle Serial Output

The output to the spindle in spindle serial output is a digital data.

Therefore assume the following relation for calculation:

Spindle analog output (voltage) 10V = Spindle serial output (digital data) 4095.

The above calculation becomes as follows:

The value of Spindle output D:

(i) G96

$$D = \frac{4095S}{2\pi rR}$$

R: Spindle speed (min^{-1}) at maximum spindle motor speed (that is , spindle speed set by parameter No. 3741 to No. 3744)

S: Surface speed (m/min) specified by S

r: Radius value in the X-axis direction (m)

(ii)G97

$$D = \frac{4095N}{R}$$

R: Spindle speed at maximum spindle motor speed (min^{-1})

N: Spindle speed given by S command (min^{-1})

Constant surface speed control with no position coder (T series)

In a machine with no position coder (or without using a position coder), it is usually impossible to use feed per rotation during constant surface speed control. Setting parameter FPR (bit 2 of parameter No. 1405) to 1, however, makes it possible to use feed per revolution in a machine with no position coder (or without using a position coder) even when it is under constant surface speed control. In this type of feed per revolution, it is assumed that the spindle speed is specified by the 12-bit S code signal R010 to R120 <F036#0 to F037#3>.

NOTE

This function is valid only for the spindle connected to the system of interest.

For example, the following program is executed with G code system B and diameters specified.

```

N1 G00 X50. Z10. ;
N2 G96 G95 S12 ;           ← Constant surface speed control and
                           feed per revolution begin.
N3 G01 X20. Z30. F10. ;
N4 Z50. ;
N5 G97 S200 ;             ← Constant surface speed control ends.
N6 G00 Z200. ;
N7 M30 ;

```

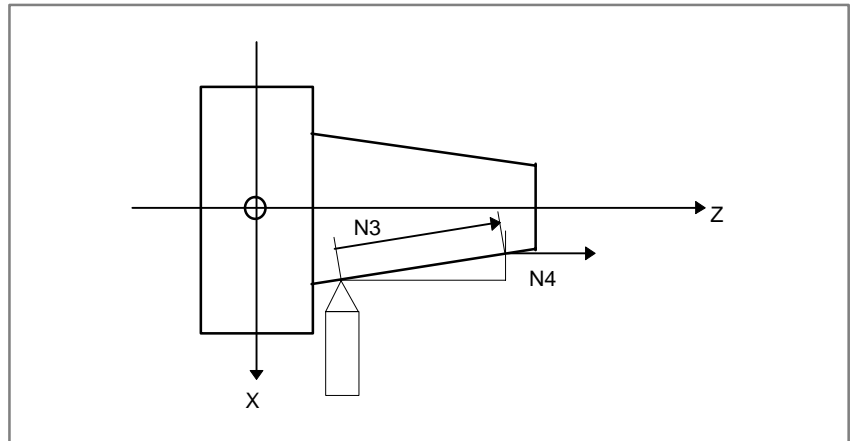

In this program, block N2 issues a constant surface speed control command (G96), a surface speed command (S12 m/min), and a feed-per-revolution command (G95). Block N3 causes the CNC to change the spindle speed specification from 76.4 min⁻¹ to 191 min⁻¹ so as to maintain a constant surface speed during movement to X = 20.

Meanwhile, the feed-per-revolution speed is changed according to the changed spindle speed specification, and used for movement along the feed axis. However, the specified spindle speed is clamped to the upper limit to the spindle speed specification (for the first spindle, using parameter No. 3772). In the above program, the feed-per-revolution speed command F10 in block N3 corresponds to an actual speed of 764 (mm/min) to 1910 (mm/min).

Signal

Gear selection signal (Input)

GR2, GR1 <G028#2, #1>

Refer to section 9.3 “Spindle Speed Control”.

Constant surface speed signal CSS <F002#2>

[Classification] Output signal

[Function] This signal indicates that constant surface speed control is in progress.

[Output condition] “1” indicates that constant surface speed control mode (G96) is in progress, while “0” indicates it is not.

Signal address

	#7	#6	#5	#4	#3	#2	#1	#0
F002						CSS		

Parameter

	#7	#6	#5	#4	#3	#2	#1	#0
1405						FPR		

[Data type] Bit

FPR Specifies the feed-per-revolution function with no position coder.
 0 : Not used.
 1 : Used.

NOTE

If you set this parameter to 1, reset parameter NPC (bit 0 of parameter No. 1402) to 0.

3741	Maximum spindle speed for gear 1
3742	Maximum spindle speed for gear 2
3743	Maximum spindle speed for gear 3
3744	Maximum spindle speed for gear 4

[Data type] Word

[Unit of data] min⁻¹

3770	Axis as the calculation reference in constant surface speed control
------	---

[Data type] Byte

[Valid data range] 0, 1, 2, 3, ..., number of control axes
 set the axis as the calculation reference in constant surface speed control.

NOTE

When 0 is set, constant surface speed control is always applied to the X-axis. In this case, specifying P in a G96 block has no effect on the constant surface speed control.

3771	Minimum spindle speed in constant surface speed control mode (G96)
------	--

[Data type] Word

[Unit of data] min⁻¹

[Valid data range] 0 to 32767

Set the minimum spindle speed in the constant surface speed control mode (G96).

The spindle speed in constant surface speed control is clamped to the speed given by parameter 3771.

3772

Maximum spindle speed

[Data type] Word**[Unit of data]** min⁻¹**[Valid data range]** 0 to 32767

This parameter sets the maximum spindle speed.

When a command specifying a speed exceeding the maximum spindle speed is specified, or the spindle speed exceeds the maximum speed because of the spindle speed override function, the spindle speed is clamped at the maximum speed set in the parameter.

NOTE

- 1 In the M series, this parameter is valid when the constant surface speed control option is present.
- 2 When the constant surface speed control option is present, the spindle speed is clamped at the maximum speed, regardless of whether the G96 mode or G97 mode is specified.

Alarm and message

Number	Message	Description
190	ILLEGAL AXIS SELECT	The axis specification is wrong in constant surface speed control. (See parameter No. 3770.) The specified axis command (P) contains an illegal value. Correct the program.

Caution**CAUTION**

- 1 If the spindle speed corresponding to the calculated surface speed exceeds the speed specified in the spindle speed clamp command (G50S_ for T series and G92S_ for M series) during the G96 mode, the actual spindle speed is clamped at the value specified in the spindle speed clamp command.
If the specified spindle speed is lower than the value specified in parameter No. 3771, the actual spindle speed is clamped at the speed specified by No. 3771.
- 2 If the constant surface speed control function is provided for a machining center system, it affects gear change under normal spindle control. (See Section 9.3.)

Note**NOTE**

Simultaneous use of multi-spindle control enables constant surface speed control for spindles other than the first spindle. (See Section 9.10.)

Reference item

Series 16i/18i/160i/180i/ 160is/180is	OPERATOR'S MANUAL (For Machining Center) (B-63534EN)	II.9.3	CONSTANT SURFACE SPEED CONTROL (G96, G97)
	OPERATOR'S MANUAL (For Lathe) (B-63524EN)	II.9.3	CONSTANT SURFACE SPEED CONTROL (G96, G97)
Series 21i/210i/210is	OPERATOR'S MANUAL (For Machining Center) (B-63614EN)	II.9.3	CONSTANT SURFACE SPEED CONTROL (G96, G97)
	OPERATOR'S MANUAL (For Lathe) (B-63604EN)	II.9.3	CONSTANT SURFACE SPEED CONTROL (G96, G97)
Series 20i	OPERATOR'S MANUAL (For Manual Lathes) (B-64194EN)	II.9.3	CONSTANT SURFACE SPEED CONTROL (G96, G97)

9.6 SPINDLE SPEED FLUCTUATION DETECTION

General

With this function, an overheat alarm (No. 704) is raised and the spindle speed fluctuation detection alarm signal SPAL is issued when the spindle speed deviates from the specified speed due to machine conditions.

This function is useful, for example, for preventing the seizure of the guide bushing.

G26 enables spindle speed fluctuation detection.

G25 disables spindle speed fluctuation detection.

Detection of Spindle Speed Fluctuation

The function for detecting spindle speed fluctuation checks whether the actual speed varies for the specified speed or not. Sd or Sr, whichever is greater, is taken as the allowable fluctuation speed (Sm). An alarm is activated when the actual spindle speed varies for the commanded speed (Sc) under the condition that the variation width exceeds the allowable variation width (Sm).

Sd: The allowable constant variation width which is independent of the specified spindle speed (Sd is set with parameter No. 4913.)

Sr: The allowable variation width which is obtained by multiplying Sc (commanded spindle speed) by r (constant ratio). (r is set with parameter No. 4912.)

Sm: Sd or Sr, whichever is greater

Conditions to start spindle speed fluctuation detection

If the specified spindle speed Sc changes, spindle speed fluctuation detection starts when one of the conditions below is met:

- The actual spindle speed falls in a range of (Sc - Sq) to (Sc + Sq)

where $Sq = Sc \times q/100$

q: Percent tolerance of the target spindle speed, specified in parameter No. 4911. If the actual spindle speed is in a range of the specified speed $\pm q$, it is assumed that the actual speed has reached the specified speed.

- When time p specified in parameter No. 4914 elapses after the specified speed Sc changes.

Parameter No. 4914, 4911, and 4912 can be rewritten also by program (G26 PpQqRr).

1. When an alarm is issued after a specified spindle speed is reached

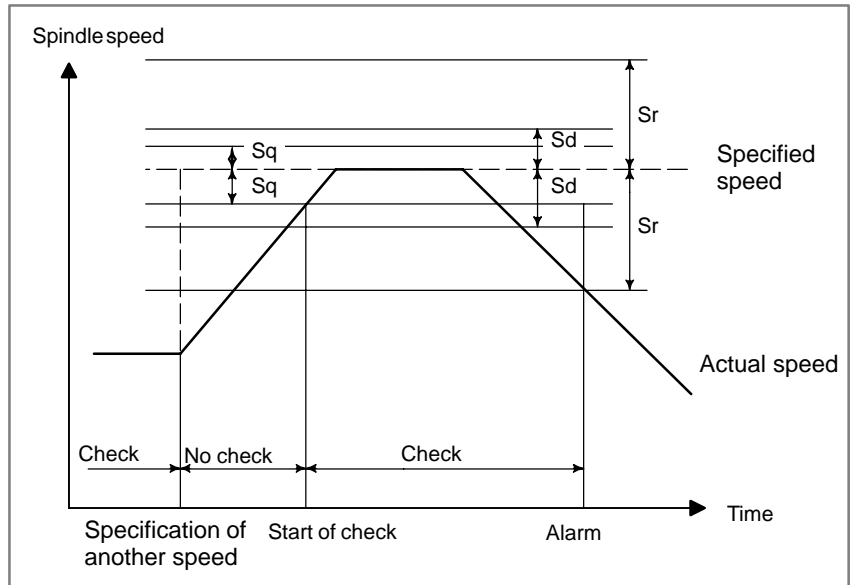

2. When an alarm is issued before a specified spindle speed is reached

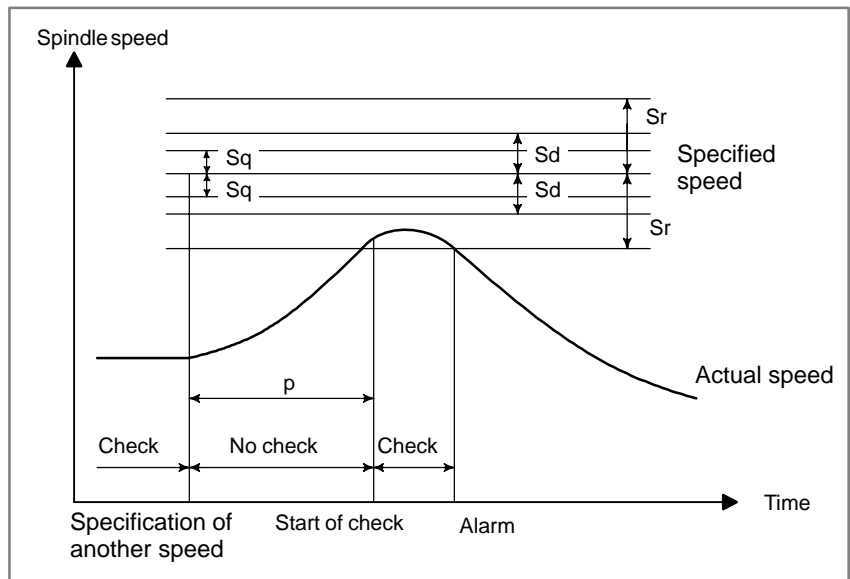

Specified speed :

(Speed specified by address S and five-digit value) × (spindle override)

Actual speed : Speed detected with a position coder

Signal

Spindle fluctuation detection alarm signal SPAL <F035#0>

[Classification] Output signal

[Function] This signal indicates that the actual spindle speed is not within a tolerance to the specified speed.

[Output condition] The signal becomes logical “1” when:

- The actual spindle speed goes out of tolerance to the specified speed.

The signal becomes logical “0” when:

- No alarm condition has been detected for spindle speed fluctuation.
- An alarm condition is cleared by resetting the NC when the signal is logical “1”.

Signal address

	#7	#6	#5	#4	#3	#2	#1	#0
F035								SPAL

Parameter

	#7	#6	#5	#4	#3	#2	#1	#0
3708				SVD				

[Data type] Bit

SVD When the SIND signal is on, the detection of spindle speed fluctuation is:

- 0 : Disabled
- 1 : Enabled

	#7	#6	#5	#4	#3	#2	#1	#0
4900								FLR

[Data type] Bit

FLR When the spindle speed fluctuation detection function is used, the rates of allowance (q) and fluctuation (r) those are set in parameter No. 4911 and No. 4912, respectively are set in steps of:

- 0 : 1%
- 1 : 0.1%

4911 Percent tolerance (q) of the target spindle speed to begin checking

[Data type] Word

[Unit of data]	Unit of data	1%	0.1% (T series)
[Valid data range]	Data range	1 – 100	1 – 1000

NOTE
Unit of data depends on parameter No. 4900#0 FLR (T series only)

Set the percent tolerance (q) of the target spindle speed to begin checking.

4912 Spindle speed fluctuation ratio (r) for which no alarm is activated in the spindle speed fluctuation detection function

[Data type] Word

[Unit of data]	Unit of data	1%	0.1% (T series)
[Valid data range]	Data range	1 – 100	1 – 1000

NOTE
Unit of data depends on parameter No. 4900#0 FLR (T series only).

Set the spindle speed fluctuation ratio (r) for which no alarm is activated in the spindle speed fluctuation detection function.

4913 Spindle speed fluctuation value (d) for which no alarm is activated in the spindle speed fluctuation detection function

[Data type] Word

[Unit of data] min⁻¹

[Valid data range] 0 to 32767

Set the allowable fluctuation speed (d) for which no alarm is activated in the spindle speed fluctuation detection function.

4914 Time (p) elapsed from when the commanded spindle speed is changed to the start of spindle speed fluctuation detection

[Data type] Two-word

[Unit of data] msec

[Valid data range] 0 to 999999

Set the time (p) elapsed from when the specified spindle speed is changed to the start of spindle speed fluctuation detection. The fluctuation in the spindle speed is not detected until the specified time elapses from when the specified spindle speed is changed.

Alarm and message

Number	Message	Description
704	OVER HEAT : SPINDLE	Spindle overheat in the spindle fluctuation detection (1) If the cutting load is heavy, relieve the cutting condition. (2) Check whether the cutting tool is share. (3) Another possible cause is a faulty spindle amp.

Note

NOTE

- 1 When an alarm is issued in automatic operation, a single block stop occurs.
- 2 No check is made during spindle stop state (*SSTP = 0).
- 3 An alarm is issued one second later if the actual spindle speed is found to be 0 min⁻¹.
- 4 Issuing the alarm does not cause the spindle to stop automatically.

Reference item

Series 16i/18i/160i/180i/ 160is/180is	OPERATOR'S MANUAL (For Machining Center) (B-63534EN)	II.9.4	SPINDLE SPEED FLUCTUATION DETECTION FUNCTION (G25, G26)
	OPERATOR'S MANUAL (For Lathe) (B-63524EN)	II.9.4	SPINDLE SPEED FLUCTUATION DETECTION FUNCTION (G25, G26)
Series 21i/210i/210is	OPERATOR'S MANUAL (For Lathe) (B-63604EN)	II.9.4	SPINDLE SPEED FLUCTUATION DETECTION FUNCTION (G25, G26)

9.7 ACTUAL SPINDLE SPEED OUTPUT (T SERIES)

General The PMC can read actual spindle speed.

Signal

Actual spindle speed signal AR0 to AR15 <F040, F041>

[Classification] Output signal

[Function] These 16-bit binary code signals output from the CNC to the PMC the actual spindle speed obtained by feedback pulses from the position coder mounted on the spindle.

[Operation] Spindle speed $= \sum_{i=0}^{15} \{2^i \times V_i\} \text{min}^{-1}$

where $V_i = 0$ when AR_i is "0" and $V_i = 1$ when AR_i is "1"

Signal address

	#7	#6	#5	#4	#3	#2	#1	#0
F040	AR7	AR6	AR5	AR4	AR3	AR2	AR1	AR0
F041	AR15	AR14	AR13	AR12	AR11	AR10	AR09	AR08

Note

NOTE

- 1 The AR0 - AR15 signals are always output. Their values change every 64 msec.
- 2 An absolute error of about 0.5 min^{-1} exists as a measuring error.

9.8 SPINDLE POSITIONING (T SERIES)

General

This function positions the spindle using the spindle motor and position coder.

The function has a coarser least command increment compared with the Cs contour control function and has no interpolation capability with other axes. However, it can be installed more easily because the position detector is a position coder.

Generally, the spindle positioning axes are clamped mechanically except when positioning is under way.

In the turning process, the workpiece is rotated by the spindle to which it is attached (spindle rotation mode), at the speed specified for the spindle motor. The value for the spindle speed is input from the spindle controller to the spindle amplifier.

When the optional spindle positioning function is activated, the spindle is moved to a defined angle, and the workpiece is repositioned at that angle. The specified move distance is input to the error counter, and the velocity command is issued for the spindle motor through the spindle amplifier. The position of the spindle is detected by the installed position coder (Spindle positioning mode).

The spindle positioning function can perform the following operations:

- Release the spindle rotation mode and enter the spindle positioning mode
Specifying a particular M code sets a reference position in the spindle positioning mode. (This is called spindle orientation.)
- Position the spindle in the spindle positioning mode
Position an optional angle using address C (H), and position a semi-fixed angle using a specific M code parameter.
- Release the spindle positioning mode and enter the spindle rotation mode
Specifying a particular M code parameter changes the spindle to the spindle rotation mode.

Also, relationship between M codes and these operations are set by parameters (refer to No. 4950#2 (ISZ), #7 (IMB)).

· Least command increment

$$\frac{360}{4096} \doteq 0.088 \text{ deg}$$

· Minimum input increment

0.001 deg

· Maximum command value

±9999.999 deg

Selecting a spindle positioning axis

Any axis in the control axis group can be used as the C axis (parameter no. 1020). Specify `-1` as its servo axis number (parameter no. 1023).

Only one set of this setting can be used for each control path. The spindle subjected to spindle positioning is the first spindle.

Switching to spindle positioning mode (Spindle orientation)

Orientation is required in advance if spindle positioning is first performed after the spindle motor is used as a normal spindle, or when spindle positioning is interrupted. The orientation stops the spindle in a constant position. The orientation position can be sifted in the range of $\pm 180\text{deg}$ for analog spindle and in the range from 0 to 360° for serial spindle.

To specify orientation, use the M code specified in parameter No. 4960.

The orientation direction is specified by using parameters ZMIx No. 1006 #5 for analog or RETURN No. 4000#5 for serial spindles.

• Orientation speed

The spindle moves at rapid traverse (set by parameter No. 1420) until it reaches the orientation enable speed (shown below). After the spindle crosses that speed point, it performs orientation at the speed set by parameter No. 1425. When a serial spindle is used, orientation speed depends on the spindle.

- Orientation enable speed
 $\text{RPD} > 9 \times (\text{loop gain}) \text{ KPPM}$
 Loop gain: Parameter No. 4970 (unit: 1/sec)
 Set rapid traverse speed at above value.

(Example)

When the loop gain parameter No. 4970 is set to 20 [1/sec], the orientation speed is:

$$\text{RPD} > 9 \times 20 \times 1000 \times (360/4096) = 15820 \text{ [deg /min]}$$

The serial spindle stops at the orientation position as soon as the command is issued. The lower limit to the rapid traverse speed value does not need to be specified for the serial spindle to reach the orientation enable speed.

The analog spindle stops after the spindle speed is changed from rapid traverse to the FL speed. The rapid traverse speed lower limit must be specified for the analog spindle, or obtaining the orientation enable speed need not be specified for the serial spindle. However, it must be specified for the analog spindle.

• Program origin

The orientation position is regarded as a program origin. It is possible to modify the program origin using the coordinates system or automatic coordinates system settings (parameter ZPR No. 1201#0)

Command system

- **Semi-fixed angle positioning by M code**

The command system comes in two types: The first positions a semi-fixed angle; the second positions an optional angle.

A 2-digit numerical value following the M address is used for the command. There are six positioning angle values ($M\alpha$ to $M(\alpha + 5)$), where α is set by parameter No. 4962. Indexing angle β also requires prior parameter setting data No. 4963. Rotation can be done in any direction, using parameter IDM data No. 4950#1.

Also, when extended specification is used (parameter No. 4950#6 ESI=1), max. 256 kinds of values ($M\alpha$ to $M(\alpha+255)$) can be specified.

M-code	Indexing angle	eg) when $\beta=30^\circ$
$M\alpha$	β	30°
$M(\alpha+1)$	2β	60°
$M(\alpha+2)$	3β	90°
$M(\alpha+3)$	4β	120°
$M(\alpha+4)$	5β	150°
$M(\alpha+5)$	6β	180°

- **Optional angle positioning by C or H address**

Numerical value following either the C or H address is used to command the position. C and H addresses are commanded in G00 mode.

(Example) C-1000

H4500

(i) Minimum setting unit :

0.001deg

(ii) Maximum command value:

± 9999.999 deg

(iii) Decimal point input: A numerical value with decimal point can be entered. The decimal point location is in “degrees”, for instance:

C35.0=C35 degrees

● **Absolute and incremental commands**

Positioning by specifying a semi-fixed angle (by M code) is always incremental. To perform positioning by specifying an optional angle, specify the distance between the program origin and the end point (absolute) with address C and the distance between the start point and the end point (incremental) with address H.

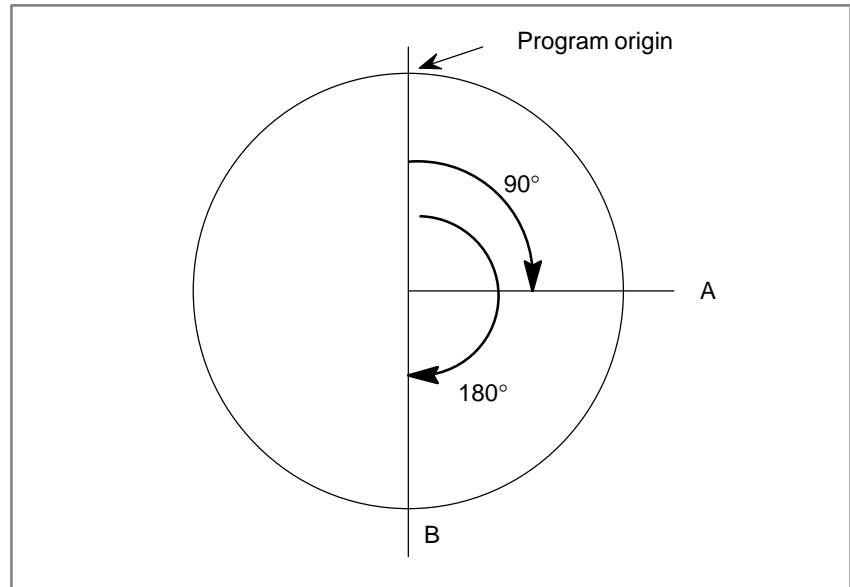

Command method		G code system A		G code system B, C	
		Address used	Command of A→B on the above Fig.	Address used and G-code	Command of A→B on the above Fig.
Absolute command	Direct the end point position by the distance from the program origin.	C	C180.0 ;	G90,C	G90C180.0 ;
Incremental command	Command by the distance between the start and end points.	H	H90.0 ;	G91,C	G91C90.0 ;

● **Spindle positioning feedrate**

Spindle positioning is done at the rapid traverse rate specified by parameter No. 1420, to which linear acceleration deceleration are applied. Overrides of 100%, 50%, 25% and F0 (parameter No. 1421) are also applied.

● **Spindle positioning reset**

A specific M code (parameter no. 4961) must be set when the mode is changed from spindle positioning to normal spindle rotation.

Signal

Spindle stop complete signal SPSTP <G028#6>

[Classification] Input signal

[Function] When this signal is 1, the CNC orients and positions the spindle.

Spindle unclamp signal SUCLP <F038#1>

[Classification] Output signal

[Function] This signal specifies that spindle mechanical clamping be released in a spindle positioning sequence.

When this signal is output, unclamp the spindle on the machine (release the brakes or extract the pin).

[Output condition] Refer to the sequence (time chart) in this section.

Spindle unclamp completion signal *SUCPF <G028#4>

[Classification] Input signal

[Function] This signal indicates that unclamping the spindle is complete in response to the spindle unclamp signal SUCLP.

Spindle clamp signal SCLP <F038#0>

[Classification] Output signal

[Function] This signal specifies that the spindle be clamped mechanically in a spindle positioning sequence.

When this signal turns to 1, clamp the spindle on the machine (apply the brakes or insert the pin).

[Output condition] Refer to the sequence (time chart) in this section.

Spindle clamp completion signal *SCPF <G028#5>

[Classification] Input signal

[Function] This signal indicates that clamping the spindle is complete in response to the spindle clamp signal SCLP.

Other signals

Gear selection signal
GR1, GR2, <G028#1, #2>
CTH1A, CTH2A
<G070#3, #2>

Refer to 9.3 “Spindle Speed Control.”

Refer to the manual for serial spindle.

The spindle loop gain multiplier corresponding to the gear currently selected by this signal is used. When the serial spindle is used, input gear selection signals CTH1A and CTH2A, as well.

Relationship between the selected gear and spindle gear selection signal

Analog spindle			Serial spindle		
GR2	GR1	Selected gear	CTH1A	CTH2A	Selected gear
0	0	1st gear	0	0	HIGH
0	1	2nd gear	0	1	MEDIUM HIGH
1	0	3rd gear	1	0	MEDIUM LOW
1	1	4th gear	1	1	LOW

Spindle orientation completion signal
ZPx<F094>

[Classification] Output signal

[Function] This signal indicates that the spindle orientation for the spindle positioning has been completed.

[Output condition] When spindle orientation is complete, this signal turns to 1. When spindle positioning is performed or cleared, it turns to 0.

Signal address

	#7	#6	#5	#4	#3	#2	#1	#0
G028		SPSTP	*SCPF	*SUCPF		GR2	GR1	
G070					CTH1A	CTH2A		
	#7	#6	#5	#4	#3	#2	#1	#0
F038							SUCLP	SCLP
F094	ZP8	ZP7	ZP6	ZP5	ZP4	ZP3	ZP2	ZP1

Sequence (Time chart)

▣ Spindle Orientation

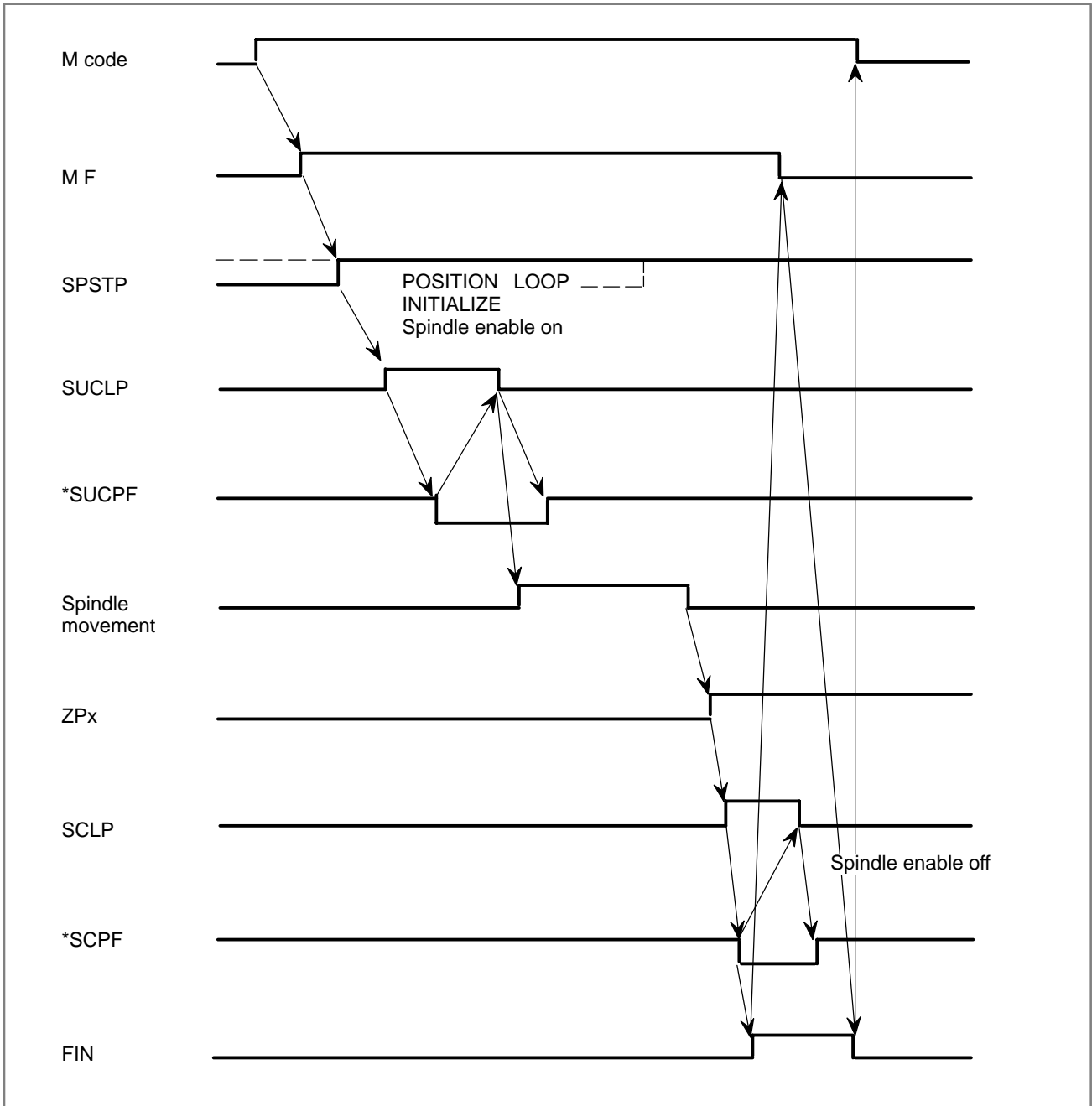

⇒ POSITION LOOP INITIALIZE is performed within the CNC.

⇒ Spindle ENABLE ON/OFF specifies that the PMC ladder direct the spindle control unit to run or stop the spindle motor.

(Example) For serial spindles, the ladder should contain the following command or something like that:

ENABLE ON, and SFRA<G070#5> ⇒ 1
 ENABLE OFF, and SFRA<G070#5> ⇒ 0

For details, refer to the manual for the spindle control unit you actually use.

▣ Spindle Positioning by M code

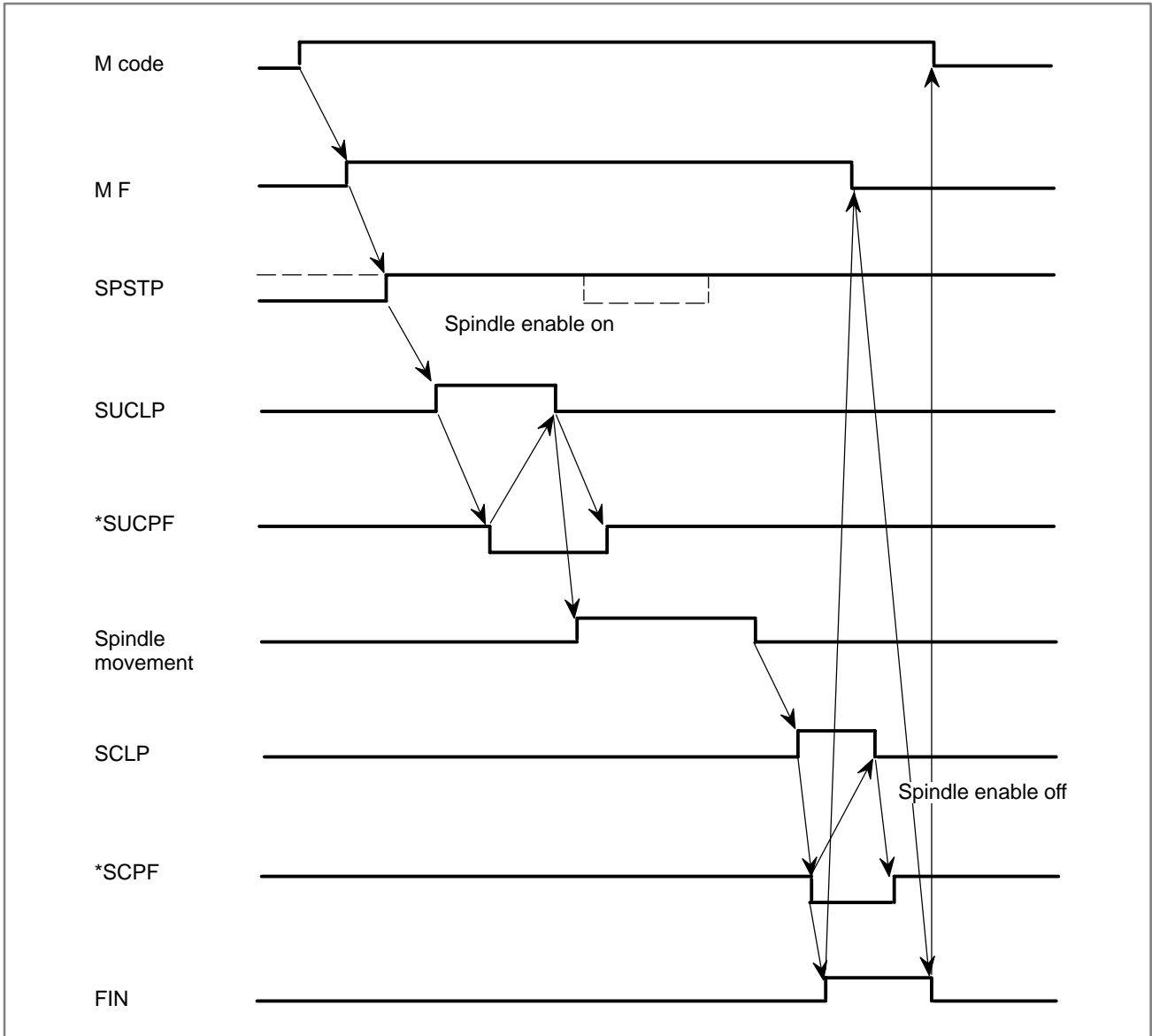

Spindle Positioning by Address C,H

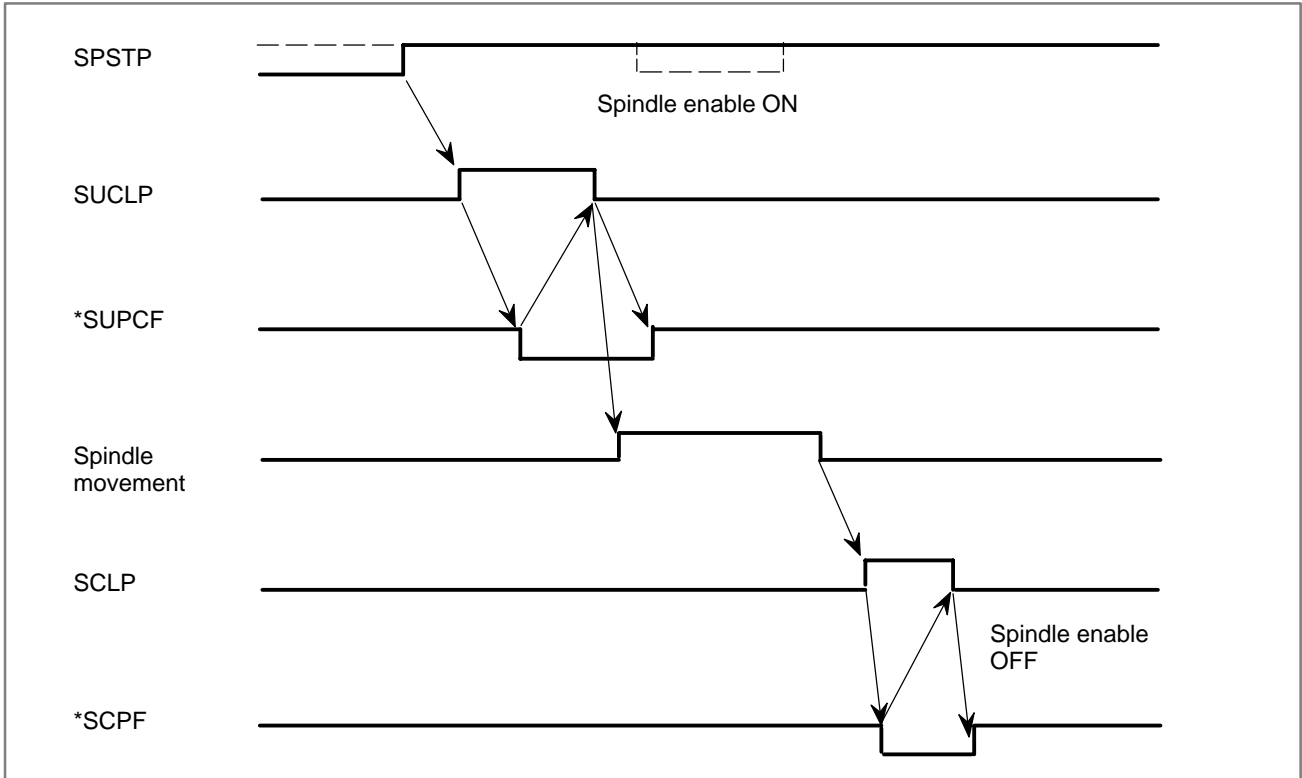

Spindle Positioning Reset

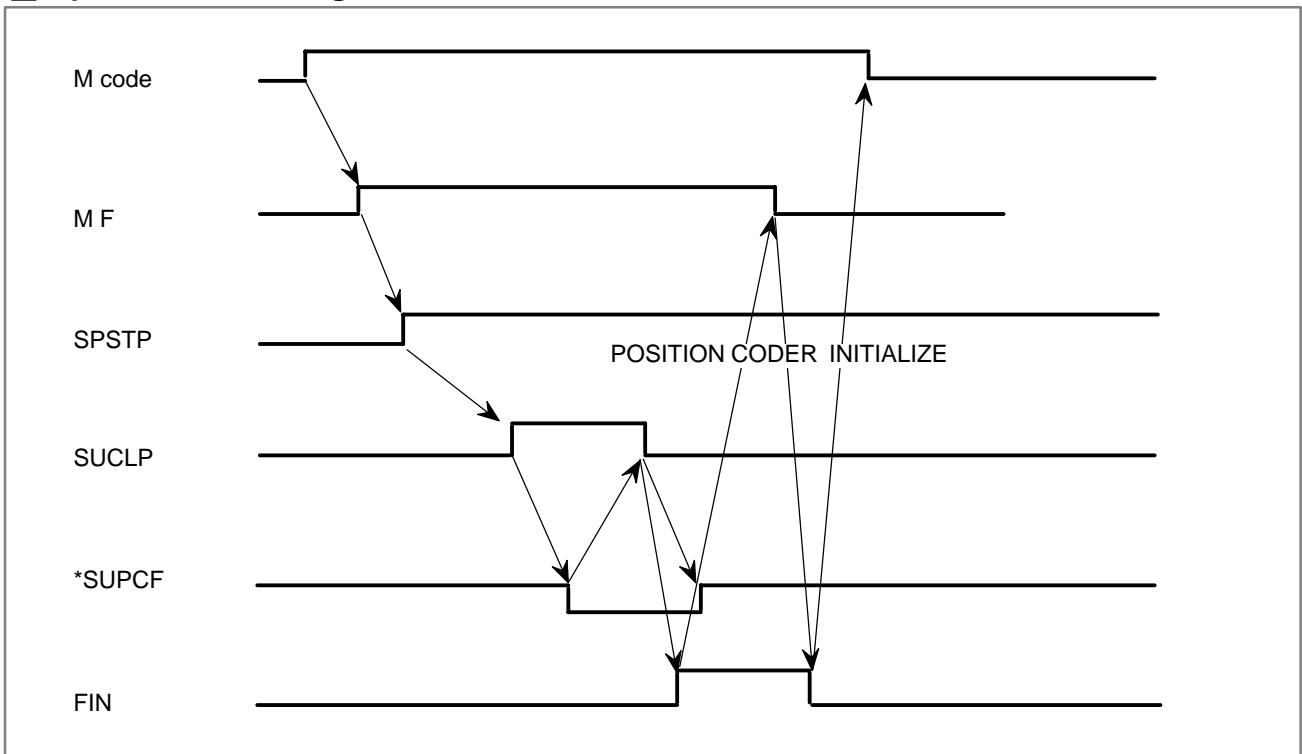

⇒ POSITION CODER INITIALIZE is performed only in the CNC.

Parameter

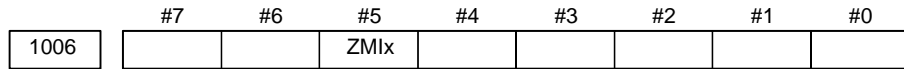

[Data type] Bit axis

ZMlx The direction of reference position return and the direction of initial backlash at power-on
 0 : Positive direction
 1 : Negative direction

NOTE
 When the serial spindle is being used, this parameter is invalid for the spindle positioning axis.

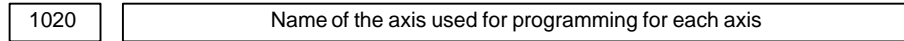

[Data type] Byte axis

Set the name of the program axis for each control axis, with one of the values listed in the following table:

Axis name	Set value	Axis name	Set value	Axis name	Set value
X	88	U	85	A	65
Y	89	V	86	B	66
Z	90	W	87	C	67

NOTE
 1 In the T series, when G code system A is used, neither U, V, nor W can be used as an axis name. Only when G code system B or C is used, U, V, and W can be used as axis names.
 2 The same axis name cannot be assigned to more than one axis.

The axis name of spindle positioning is C axis.

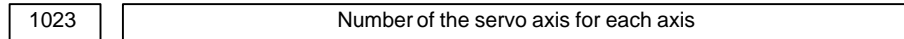

[Data type] Byte axis

Set the servo axis for each control axis.
 Generally, the same number shall be assigned to the control axis and the corresponding servo axis.
Set -1 to the C axis when spindle positioning function is used.

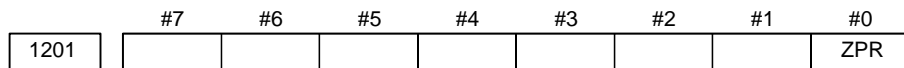

[Data type] Bit

ZPR Automatic setting of a coordinate system when the manual reference position return is performed

0 : Not set automatically
1 : Set automatically

1250	Coordinate value of the reference position used when automatic coordinate system setting is performed
------	---

[Data type] Two-word axis

Set the coordinate value of the reference position on each axis to be used for setting a coordinate system automatically.

For spindle positioning.

[Unit of data] 0.001 deg

[Valid data range] -99999999 to 99999999

1420	Rapid traverse rate for each axis
------	-----------------------------------

[Data type] Word axis

Set the rapid traverse rate when the rapid traverse override is 100% for each axis.

For spindle positioning.

[Unit of data] 10 deg/min

[Valid data range] 30 to 12000

1421	F0 rate of rapid traverse override for each axis
------	--

[Data type] Word axis

Set the F0 rate of the rapid traverse override for each axis.

For spindle positioning.

[Unit of data] deg/min

[Valid data range] 600 to 15000

1425	FL rate of the reference position return for each axis
------	--

[Data type] Word axis

Set feedrate (FL rate) after deceleration when the reference position return is performed for each axis.

For spindle positioning.

[Unit of data] deg/min

[Valid data range] 600 to 15000

NOTE

When serial spindle is used, this parameter becomes invalid.

1620	Time constant of rapid traverse linear acceleration/deceleration for each axis
------	--

[Data type] Word axis

[Unit of data] ms

[Valid data range] 0 to 4000

Set time constant of rapid traverse linear acceleration/deceleration for each axis.

	#7	#6	#5	#4	#3	#2	#1	#0
1816		DM3x	DM2x	DM1x				

[Data type] Bit axis

DM1x to DM3x Setting of detection multiply

Set this parameter to “111” (=4) for spindle positioning.

1820	Command multiply for each axis (CMR)
------	--------------------------------------

[Data type] Byte axis

- When command multiply is 1/2 to 1/27

Set value = $\frac{1}{\text{Command multiply}}$ + 100 [Valid data range: 102 to 127]

- When command multiply is 0.5 to 48

Set value = 2 × command multiply [Valid data range: 1 to 96]

Set this parameter to 2 for spindle positioning.

1821	Reference counter size for each axis
------	--------------------------------------

[Data type] Two-word axis

[Valid data range] 0 to 99999999

Set the size of the reference counter.

Set this parameter to 10000 for spindle positioning.

1826	In-position width for each axis
------	---------------------------------

[Data type] Word axis

[Unit of data] Detection unit

[Valid data range] 0 to 32767

Set the in-position width for each axis.

1828	Positioning deviation limit for each axis in movement
------	---

[Data type] Two-word axis

[Unit of data] Detection unit

[Valid data range] 0 to 99999999

Set the positioning deviation limit in movement for each axis.

1829	Positioning deviation limit for each axis in the stopped state
------	--

[Data type] Word axis

[Unit of data] Detection unit

[Valid data range] 0 to 32767

Set the positioning deviation limit in the stopped state for each axis.

1850	Grid shift for each axis
------	--------------------------

[Data type] Two-word axis

[Unit of data] Detection unit

[Valid data range] -99999999 to 99999999

Set a grid shift for each axis.

NOTE

Set this parameter when the analog spindle is used. When the serial spindle is used, set the value to No. 4073.

1851	Backlash compensating value for each axis
------	---

[Data type] Word axis

[Unit of data] Detection unit

[Valid data range] -9999 to +9999

Set the backlash compensation value for each axis.

	#7	#6	#5	#4	#3	#2	#1	#0
3405				CCR				

[Data type] Bit

CCR Addresses used for chamfering and corner rounding

0 : Address used for chamfering and corner rounding is I or K, not C. In direct drawing dimension programming, addresses 'C, 'R, and 'A (with comma) are used in stead of C, R, and A.

1 : Addresses used for chamfering, corner rounding, and direct drawing dimension programming are C and R without comma. Thus, addresses C cannot be used as the names of axes.

Always set this parameter to "0" for spindle positioning.

	#7	#6	#5	#4	#3	#2	#1	#0
4000					RETRN			

[Data type] Bit

RETRN Reference position return direction of spindle.

0 : CCW (Counter clockwise)

1 : CW (Clockwise)

NOTE

The direction for spindle orientation (or reference position return) in spindle positioning using a serial spindle is determined by this parameter.

4044	Velocity loop proportion gain in servo mode (High gear)
4045	Velocity loop proportion gain in servo mode (Low gear)

[Data type] Word

[Valid data range] 0 to 32767

This parameter sets a velocity loop proportional gain in servo mode (spindle positioning, rigid tapping, etc.)

NOTE

Set this parameter when serial spindle is used.

4052	Velocity loop integral gain in servo mode (High gear)
4053	Velocity loop integral gain in servo mode (Low gear)

[Data type] Word

[Valid data range] 0 to 32767

This parameter sets a velocity loop integral gain in servo mode (spindle positioning, rigid tapping, etc.)

NOTE

Set this parameter when serial spindle is used.

4056	Gear ratio (HIGH)
4057	Gear ration (MEDIUM HIGH)
4058	Gear ratio (MEDIUM LOW)
4059	Gear ratio (LOW)

[Data type] Word

[Unit of data] Motor speed per spindle rotation $\times 100$

[Valid data range] 0 to 32767

These parameters set the gear ration between the spindle and AC spindle motor.

NOTE

Set the gear ration between spindle and AC spindle motor when the spindle positioning is performed with serial spindle. For which gear is used, it depends on the clutch/gear signal (serial spindle) CTH1A, CTH1B.

4065	Position gain in servo mode (HIGH)
4066	Position gain in servo mode (MEDIUM HIGH)
4067	Position gain in servo mode (MEDIUM LOW)
4068	Position gain in servo mode (LOW)

[Data type] Word

[Unit of data] 0.01 sec^{-1}

[Valid data range] 0 to 32767

This parameter sets a servo loop gain in servo mode.
(spindle positioning, rigid tapping, etc.)

NOTE

When the spindle positioning by a serial spindle is performed, set the position control loop gain in place of parameter No. 4970. For which gear is used, it depends on the clutch/gear signal (serial spindle) CTH1A, CTH1B.

	#7	#6	#5	#4	#3	#2	#1	#0
4950	IMB	ESI	TRV			ISZ	IDM	IOR

[Data type] Bit

IOR Resetting the system in the spindle positioning mode

0 : Does not releases the mode.

1 : Releases the mode

IDM The positioning direction for the spindle using a M code is

0 : The positive direction

1 : The negative direction

ISZ When an M code for spindle orientation is specified in spindle positioning:

0 : The spindle rotation mode is cleared and the mode is switched to the spindle positioning mode, and spindle orientation operation is performed.

1 : The spindle rotation mode is cleared and the mode is switched to the spindle positioning mode but spindle orientation operation is not performed.

TRV Direction of rotation of spindle positioning

0 : Normal

1 : Reverse

ESI Selection of a spindle positioning specification

- 0 : The conventional specification is used.
 1 : The extended specification is used.

NOTE

The extended specification includes the following two extensions:

- With the conventional specification, the number of M codes for specifying a spindle positioning angle is always 6. With the extended specification, an arbitrary number of such M codes from 1 to 256 can be selected by parameter setting (See parameter No. 4964.)
- The maximum feedrate for spindle positioning (setting of parameter No. 1420) can be extended from 240000 to 269000 (unit: 10 deg/min).

IMB When the spindle positioning function is used, semi-fixed angle positioning based on M codes uses:

- 0 : Specification A
 1 : Specification B

NOTE

In the case of semi-fixed angle positioning based on M codes, three types of spindle positioning operations can occur:

- (1) The spindle rotation mode is cleared, then the mode is switched to the spindle positioning mode.
- (2) Spindle positioning is performed in the spindle positioning mode.
- (3) The spindle positioning mode is cleared, then the mode is switched to the spindle rotation mode.

In the case of specification A:

Operations (1) to (3) are specified using separate M codes.

- (1)–Specified using M codes for performing spindle orientation.
(See parameter No. 4960)
- (2)–Specified using M codes for specifying a spindle positioning angle. (See parameter No. 4962)
- (3)–Specified using M codes for clearing spindle positioning operation. (See parameter No. 4961.)

In the case of specification B:

When M codes for specifying a spindle positioning angle are specified, operations (1) to (3) are performed successively. (See parameter No. 4962.)

4960	M code specifying spindle orientation
------	---------------------------------------

[Data type] Word

[Unit of data] Integer

[Valid data range] 6 to 97

Set an M code to change the spindle rotating mode to the spindle positioning mode. Setting the M code performs the spindle orientation. Spindle positioning can be specified from the next block.

4961	M code releasing the spindle positioning mode
------	---

[Data type] Word

[Unit of data] Integer

[Valid data range] 6 to 97

Set the M code to release the spindle positioning mode and to change the mode to the spindle rotating mode.

4962	M code for specifying a spindle positioning angle
------	---

[Data type] Word

[Unit of data] Integer

[Valid data range] 6 to 92

Two methods are available for specifying spindle positioning. One method uses address C for arbitrary-angle positioning. The other use an M code for semi-fixed angle positioning. This parameter sets an M code for the latter method.

- When bit 6 (ESI) of parameter No. 4950=0
Six M code from $M \alpha$ to $M(\alpha+5)$ are used for semi-fixed angle positioning, when α is the value of this parameter.
- When bit 6(ESI) of parameter No. 4950=1
Set the start M code in this parameter, and set the number of M codes in parameter No. 4964. Then β M codes from $M\alpha$ to $M(\alpha+\beta-1)$ are used for semi-fixed angle positioning.

The table below indicates the relationship between the M codes and positioning angles.

M code	Positioning angle	Example: Positioning angle when $\theta = 30^\circ$
$M\alpha$	θ	30°
$M (\alpha+1)$	2θ	60°
$M (\alpha+2)$	3θ	90°
$M (\alpha+3)$	4θ	120°
$M (\alpha+4)$	5θ	150°
$M (\alpha+5)$	6θ	180°
⋮	⋮	⋮
$M (\alpha+n)$	$(n+1)\theta$	

NOTE

θ represents the basic angular displacement set in parameter No. 4963.

4963

M code for specifying a spindle positioning angle

[Data type] Word

[Unit of data] deg

[Valid data range] 1 to 60

This parameter sets a basic angular displacement used for semi-fixed angle positioning using M codes.

4964

Number of M codes for specifying a spindle positioning angle

[Data type] Byte

[Unit of data] Integer

[Valid data range] 0, 1 to 255

This parameter sets the number of M codes used for semi-fixed angle positioning using M codes.

As many M codes as the number specified in this parameter, starting with the M code specified in parameter No. 4962, are used to specify semi-fixed angle positioning.

Let α be the value of parameter No. 4962, and let β be the value of parameter No. 4964. That is, M codes from $M\alpha$ to $M(\alpha+\beta-1)$ are used for semi-fixed angle positioning.

WARNING

Make sure that M codes from $M\alpha$ to $M(\alpha+\beta-1)$ do not duplicate other M codes.

NOTE

- 1 This parameter is valid when bit 6 (ESI) of parameter No. 4950=1.
- 2 Setting this parameter to 0 has the same effect as setting 6. That is, M code from $M\alpha$ to $M(\alpha+5)$ are used for half-fixed angle positioning.

4970

Servo loop gain of the spindle

[Data type] Word

[Unit of data] 0.01 sec^{-1}

[Valid data range] 1 to 9999

Set the servo loop gain of the spindle in the spindle positioning mode.

4971	Servo loop gain multiplier of the spindle for gear 1
4972	Servo loop gain multiplier of the spindle for gear 2
4973	Servo loop gain multiplier of the spindle for gear 3
4974	Servo loop gain multiplier of the spindle for gear 4

[Data type] Word

Set the servo loop gain multipliers of the spindle for gears 1 to 4.

The multipliers are used to convert the amount of the position deviation to the voltage used in the velocity command. Assign the data obtained from the following equation to the parameters.

$$\text{Loop gain multiplier} = 2048000 \times E \times A/L$$

where;

E: Voltage required to rotate the spindle motor at 1000 min⁻¹ in the velocity command

L: Rotation angle of the spindle per one motor rotation (normally 360)

A: Unit used for the detection (degree)

Example) Let E be 2.2 V, L be 360 degrees, and A be 0.088 degrees/pulse.

$$\text{Loop gain multiplier} = 2048000 \times 2.2 \times 0.088/360 = 1101$$

NOTE

- 1 When the voltage specified for the spindle motor is 10 V at a spindle speed of 4500 min⁻¹, E is regarded as 2.2 V.
- 2 The above parameters No. 4970 to No. 4974 are for analog spindle.

Alarm and message

Number	Message	Description
053	TOO MANY ADDRESS COMMANDS	In the chamfering and corner R commands, two or more of I, K and R are specified. Otherwise, the character after a comma(",") is not C or R in direct drawing dimensions programming. Or comma(",") was specified with parameter No. 3405#4=1. Modify the program.
056	NO END POINT & ANGLE IN CHF/CNR	Neither the end point nor angle is specified in the command for the block next to that for which only the angle is specified (A). In the chamfering or corner R command, I(K) is commanded for the X(Z) axis. Modify the program.
135	SPINDLE ORIENTATION PLEASE	Without any spindle orientation, an attempt was made for spindle indexing. Perform spindle orientation.
136	C/H-CODE & MOVE CMD IN SAME BLK.	A move command of other axes was specified to the same block as spindle indexing addresses C, H. Modify the program.
137	M-CODE & MOVE CMD IN SAME BLK.	A move command of other axes was specified to the same block as M-code related to spindle indexing. Modify the program.
194	SPINDLE COMMAND IN SYNCHRO-MODE	A contour control mode, spindle positioning (Cs-axis control) mode, or rigid tapping mode was specified during the serial spindle synchronous control mode. Correct the program so that the serial spindle synchronous control mode is released in advance.
751	SPINDLE-1 ALARM DETECT (AL-XX)	This alarm indicates in the NC that an alarm is generated in the spindle unit of the system with the serial spindle. The alarm is displayed in form AL-XX (XX is a number). The alarm number XX is the number indicated on the spindle amplifier. The CNC holds this number and displays on the screen.
752	SPINDLE-1 MODE CHANGE ERROR	This alarm is generated if the system does not properly terminate a mode change. The modes include the Cs contouring, spindle positioning, rigid tapping, and spindle control modes. The alarm is activated if the spindle control unit does not respond correctly to the mode change command issued by the NC.

Caution**CAUTION**

- 1 Feed hold is invalid during spindle positioning.
- 2 Spindle positioning stops when emergency stop is applied; restart with orientation operation.
- 3 Dry run, machine lock, and auxiliary function lock are not available during spindle positioning.
- 4 The spindle positioning function and the serial spindle Cs contour control function cannot be used together. If both functions are specified, positioning has priority.
- 5 Specify parameter No. 4962 even if semi-fixed angle positioning is not used; otherwise M codes (M00 to M05) do not work.

Note**NOTE**

- 1 Command spindle positioning with an independent block. X- and Y-axis positioning cannot be commanded to the same block.
- 2 Spindle positioning cannot be done by manual operation.
- 3 Automatic drift compensation is not effective for spindle positioning. To adjust the amount of drift compensation for each axis, set values manually and adjust the spindle amplifier to minimize the spindle motor rotation at a voltage of 0V. (parameter No. 3731). Insufficient adjustment causes poor positioning accuracy. Drift compensation is not needed with a serial spindle.
- 4 The machine coordinates for the spindle positioning axis are displayed in pulses units.

Reference item

Series 16i/18i/160i/180i/ 160is/180is	OPERATOR'S MANUAL (For Lathe) (B-63524EN)	II.9.5	SPINDLE POSITIONING FUNC- TION
Series 21i/210i/210is	OPERATOR'S MANUAL (For Lathe) (B-63604EN)	II.9.5	SPINDLE POSITIONING FUNC- TION

9.9 Cs CONTOUR CONTROL

9.9.1 Cs Contour Control

General

The Cs contour control function positions the serial spindle using the spindle motor in conjunction with a dedicated detector mounted on the spindle.

This function can perform more accurate positioning than the spindle positioning function, and has an interpolation capability with other servo axes.

- **Increment system**

Least input increment: 0.001 [deg]
Least command increment: 0.001 [deg]

- **Maximum command value**

± 99999.999 [deg]

- **Feedrate**

Rapid traverse rate: 6 to 240000 [deg/min] (parameter no.1420)

Cutting feedrate (feed per minute):

1 to 240000 [deg/min] (rotation axis)

Explanations

The speed of the serial spindle is controlled by the spindle speed control function, while the spindle positioning is controlled by the Cs contouring control function (“spindle contour control”). Spindle speed control rotates the spindle using the velocity command, while the spindle contour control rotates the spindle using the move command.

Switching between spindle speed control and spindle contour control is performed by the DI signal from the PMC.

In the Cs contour control mode, the Cs contour control axis can be operated either manually or automatically, in the same way as normal servo axes.

(For a reference position return, see the relevant description in this section.)

Setting the Cs contour control axis

The axis used for Cs contour control must be set as an axis of the axes controlled by the CNC. Using parameter no. 1023, assign “- 1” in the field corresponding to the chosen servo axis. Also set the spindle contour control axis as a rotation axis by setting ROTx of parameter No. 1006#0 and No. 1022.

Only one set of this setting can be used for each control path. The spindle that operates under Cs contour control is a serial spindle as the first spindle.

Command Address

The address for the move command in Cs contour control is the axis name specified in parameter no.1020. This address is arbitrary.

When the second auxiliary function option is provided, address B cannot be used for the name of the contour axis. For the T series machines, when either address A or C is used for the name of the contour axis, clear CCR (parameter no. 3405#4) to "0".

Setting Axes that interpolate with Cs contour axis

Up to five servo axes can be specified for linear interpolation against the Cs contour control axis, by setting defined parameters :

- When no servo axis is used for interpolation, specify "0" in parameter nos. 3900, 3910, 3920, 3930, 3940.
- When one or more servo axes are used for interpolation, set the parameter for each as follows :
 - (1) Assign the axis number (1 to 8) to each of the servo axes used for interpolation in parameter nos. 39n0 (n=0, 1, 2, 3, or 4).
 - (2) Set the loop gain for each of the servo axes specified in (1) in parameter nos. 39n1, 39n2, 39n3, 39n4. The loop gain must be the position loop gain for the Cs contour control axis or a desired value. Four parameters are provided to correspond to the four gears of the spindle. Use those parameters according to the inputs of the serial spindle clutch /gear signal CTH1A, CTH2A <G70#3, #2>.

NOTE

The fine acceleration/deceleration function cannot be used between the servo axis and Cs contour control axis.

- (3) When the number of servo axes to be used for interpolation is smaller than five, set "0" in remaining parameter nos. 39n0.

Switching spindle speed control/Cs contour control

- Switching from spindle speed control to Cs contour control

The serial spindle is put in the Cs contour control mode by setting the DI signal CON (G027#7) to "1". When the mode is switched while the spindle is rotating, the spindle stops immediately to perform the change.

- Switching from Cs contour control to spindle speed control

Turning the DI signal CON (G027#7) to "0" puts the serial spindle in spindle speed control mode. Confirm that the move command for the spindle has been completed, then specify the switch. If it is switched while the spindle is moving, the machine enters interlock, or excessive position deviation alarm occurs.

Reference Position Return of Cs Contour Control Axis

After the serial spindle is switched from spindle speed control to Cs contour control mode, the current position is undefined. Return the spindle to the reference position.

The reference position return of the Cs contour control axis is as follows:

In manual mode

After the serial spindle enters the Cs contour control mode, move the spindle in the direction of the reference position by turning on the feed axis and direction select signal (+Jn (G100) or -Jn (G102)). The spindle starts the movement to the reference position; when it reaches that position, the reference position return completion signal ZPn <F094> turns to “1”.

Turning any feed axis and direction select signal to “1” moves the tool in the reference position direction.

In the automatic mode

After the serial spindle enters the Cs contour control mode, the spindle returns to the reference position when G28 is specified. Under certain conditions, the G00 command returns the spindle to the reference position, depending upon the setting of parameter NRF no. 3700#1:

(i) G00 command

Returning to the reference position using the G00 command differs from using the G28 command or the manual method. The serial spindle can be positioned at any point using the G00 command, while the latter two methods always return the serial spindle to the reference position.

When parameter NRF no. 3700#1 is “0” and the serial spindle is put in the Cs contour control mode, if the G00 command is given before returning the spindle to the reference position, the serial spindle returns to the reference position and indexes it before moving to the commanded position. After positioning at the reference position, the reference position return completion signal ZPn <F094> turns to “1”. When the G00 command is issued after the serial spindle has returned to the reference position at least once, normal positioning operation is executed.

(ii) G28 command

After the serial spindle is put in the Cs contour control mode, issuing the G28 command stops the spindle motor, then moves the spindle to the midpoint. The spindle then returns to the reference position. At this point, the reference position return completion signal ZPn <F094> turns to “1”. When the serial spindle has returned to the reference position once while in the Cs contour control mode, the G28 command positions the spindle at the reference position without moving to the midpoint and ZPn comes on.

Interruption of reference position return

(i) Manual operation

Return to the reference position can be interrupted by resetting, emergency stop, or turning off the feed axis and direction select signal. When the interrupted return operation is resumed, start from the beginning.

(ii) Automatic operation

Return to the reference position can be interrupted by resetting, emergency stop, or feed hold. When the interrupted return operation is resumed, start from the beginning.

Operation of Cs contour control axis (Manual/Automatic)

If a reference position return is performed on the Cs contour control axis, the axis can be operated in the same way as a normal NC axis.

In the spindle speed control mode, on the other hand, it does not operate as the Cs contour control axis, and P/S alarm 197 occurs during automatic operation.

In the spindle speed mode, inhibit manual operation of the Cs contour control axis using the PMC ladder.

Display of Position Error of Cs Contour Control Axis

DGN No.

418	Position deviation amount of 1st spindle
-----	--

Position deviation amount of the position loop for the 1st spindle.

This diagnostic display shows information obtained from the serial spindle control unit. This diagnosis displays position error of the spindle contour axis during spindle contour control.

The position error can also be checked using a servo error display (DGN of No. 300x) for an axis under Cs contour control.

Signal

Spindle contour control change signal CON <G027#7>

[Classification] Input signal

[Function] This signal specifies that the first serial spindle be switched between the spindle speed control and Cs contour control modes.

When this signal turns to "1", the spindle mode changes from speed control to Cs contour control.

If the spindle is moving at the time of the change, it stops immediately. Turning the signal to "0" changes the spindle mode from Cs contour control back to speed control.

**Spindle contour control
change completion
signal FSCSL <F004#1>**

[Classification] Output signal

[Function] This signal indicates the axis is under Cs contour control.

[Output condition] Spindle speed control mode → 0

Cs contour control mode → 1

Time Chart

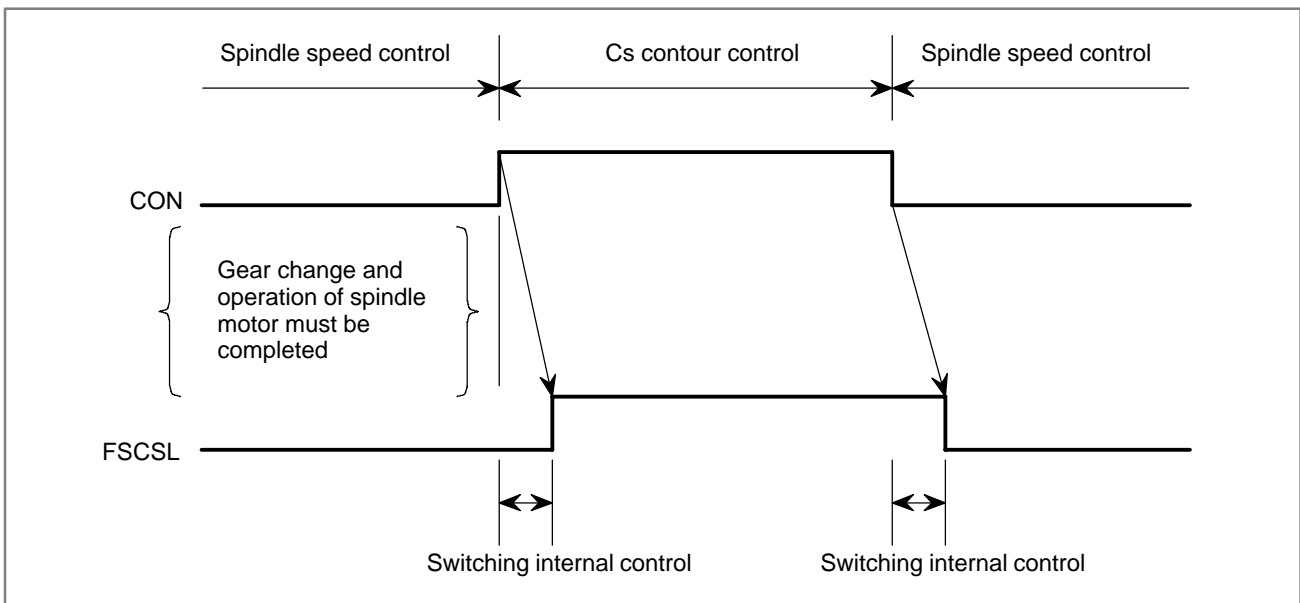

NOTE

Any mechanical gear change needed and inputs for GR1, GR2, CTH1A, and CTH2A must be completed before the CON signal selects Cs contour control mode.

A servo excessive error may be generated if the spindle motor is not ready for operation. (Signal SRVA, SFRA <G070#4, #5> or other required signals must be appropriately processed on the machine side).

Other signals

Gear select signal (Input)

GR1, GR2, <G028#1, #2>

Gear select signal

(Output)

GR30, GR20, GR10

<F034#2, #1, #0>

(M series)

Refer to 9.3 “Spindle speed Control”.

**Clutch/Gear signal
(Serial spindle)
CTH1A, CTH2A
<G070#3, #2>**

Refer to the manual of serial spindle.

These signals determine what parameter (loop gain, etc.) to be used for each gear position.

CTH1A and CTH2A are the gear select signals for the serial spindle, but GR1 and GR2 must also be set. Do not change these signals while in the Cs contour control mode.

Relationship between gears selected and spindle gear select signals

CNC side							Serial spindle		
T/M series with CSSC			M series without CSSC						
GR2	GR1	Gear selection	GR3O	GR2O	GR1O	Gear selection	CTH1A	CTH2A	Gear selection
0	0	1st stage	0	0	1	1st stage	0	0	1st stage
0	1	2nd stage	0	1	0	2nd stage	0	1	2nd stage
1	0	3rd stage	1	0	0	3rd stage	1	0	3rd stage
1	1	4th stage					1	1	4th stage

CSSC: Constant surface speed control

NOTE

- 1 When the M series does not include the constant surface speed control option, and parameter No. 3706#4 GTT=0, GR1 and GR2 do not need to be input. Input CTH1A and CTH2A when gears are changed using GR1O, GR2O and GR3O.
- 2 The above combination of clutch/gear signals CTH1A and CTH2A is an example.
The serial spindle gear is selected by CHT1A and CHT2A independently of gear selection on the CNC side. So, enter necessary signals, and set the corresponding serial spindle parameters.

**Cs contour control axis
reference position return
completion signal
ZPx <F094>**

[Classification] Output signal

[Function] This signal indicates that a reference position return has been made for the Cs contour control axis.

[Output condition] If a manual reference position return or automatic reference position return by G28 is performed during the Cs contour control mode, this signal becomes logical 1 when the Cs contour control axis reaches the reference position.

Signals on manual operation

Feed axis and direction select signal +Jn, -Jn <G100, G102> (Input)
 Manual handle feed axis select signal HSnA, HSnB, HSnC, HSnD <G018, G019> (Input) (Refer to respective items in this manual)

The Cs contour control axis can be manually operated in the same way as normal servo axes, except for a manual reference position return. In the spindle speed control mode, however, manual operations for the Cs contour control axis must be inhibited using the PMC ladder, etc.

Signal address

	#7	#6	#5	#4	#3	#2	#1	#0
G027	CON							
G028						GR2	GR1	
G070	MRDYA		SFRA	SRVA	CTH1A	CTH2A		
	#7	#6	#5	#4	#3	#2	#1	#0
F034						GR30	GR20	GR10
F044							FSCSL	
F094	ZP8	ZP7	ZP6	ZP5	ZP4	ZP3	ZP2	ZP1

Parameter

The following describes major parameters.

In addition, parameters such as axis feedrate, acceleration/deceleration, and display can be used. Also, digital servo parameters (No. 2000 or later) for the Cs contour axis are not required to be set.

	#7	#6	#5	#4	#3	#2	#1	#0
1006								ROT _x

[Data type] Bit axis

Type of controlled axis

0 : Linear axis

1 : Rotation axis

NOTE

Inch/metric conversion cannot be made to the rotation axis. The machine coordinate values are rounded in 0 to 360 deg. Automatic reference position return (G28, G30) is made in the manual reference position return direction and the move amount does not exceed one rotation.

Set 1 as the rotation axis to the Cs contour control axis.

1020

Name of the axis used for programming for each axis

[Data type] Byte axis

Set the name of the program axis for each control axis, with one of the values listed in the following table:

Axis name	Set value	Axis name	Set value	Axis name	Set value	Axis name	Set value
X	88	U	85	A	65	E	69
Y	89	V	86	B	66	–	–
Z	90	W	87	C	67	–	–

NOTE

- 1 In the T series, when G code system A is used, neither U, V, nor W can be used as an axis name. Only when G code system B or C is used, U, V, and W can be used as axis names.
- 2 The same axis name cannot be assigned to more than one axis.
- 3 When the second auxiliary function is provided, address B cannot be used as an axis name. In the T series, when address A or C is used, set parameter CCR (No. 3405#4) to 0.
- 4 If you use letter E as an axis name in format F15, be sure to use address F in the major-axis direction lead command for equal-lead threading (G32).

Any axis name can be used for Cs contour control axis except for above limitation.

1022

Setting of each axis in the basic coordinate system

[Data type] Byte axis

Only one axis can be set for each of the three basic axes X, Y, and Z, but two or more parallel axes can be set.

Set value	Meaning
0	Neither the basic three axes nor a parallel axis
1	X axis of the basic three axes
2	Y axis of the basic three axes
3	Z axis of the basic three axes
5	Axis parallel to the X axis
6	Axis parallel to the Y axis
7	Axis parallel to the Z axis

Set 0 to the Cs contour control axis.

1023	Number of the servo axis for each axis
------	--

[Data type] Byte axis

Set the servo axis for each control axis.

Generally, the same number shall be assigned to the control axis and the corresponding servo axis.

Set -1 as the number of servo axis to the Cs contour control axis.

1201	#7	#6	#5	#4	#3	#2	#1	#0
								ZPR

[Data type] Bit

ZPR Automatic setting of a coordinate system when the manual reference position return is performed

0 : Not set automatically

1 : Set automatically

1250	Coordinate value of the reference position used when automatic coordinate system setting is performed
------	---

[Data type] Two-word axis

Set the coordinate value of the reference position on each axis to be used for setting a coordinate system automatically.

1420	Rapid traverse rate for each axis
------	-----------------------------------

[Data type] Word axis

[Unit of data] 1 deg/min

[Valid data range] 30 to 240000 (IS-A, IS-B)
6 to 100000 (IS-C)

Set the rapid traverse rate when the rapid traverse override is 100% for each axis.

1620	Time constant used in linear acceleration/deceleration or bell-shaped acceleration/deceleration in rapid traverse for each axis
------	---

[Data type] Word axis

[Unit of data] ms

[Valid data range] 0 to 4000

Set the time constant used in linear acceleration/deceleration in rapid traverse for each axis.

1820	Command multiply for each axis (CMR)
------	--------------------------------------

[Data type] Byte axis

- When command multiply is 1/2 to 1/27

$$\text{Set value} = \frac{1}{(\text{Command multiply})} + 100 \quad [\text{Valid data range: } 102 \text{ to } 127]$$

- When command multiply is 0.5 to 48

$$\text{Set value} = 2 \times \text{command multiply} \quad [\text{Valid data range: } 1 \text{ to } 96]$$

1826	In-position width for each axis
------	---------------------------------

[Data type] Word axis

[Unit of data] Detection unit

[Valid data range] 0 to 32767

Set the in-position width for each axis.

1828	Positioning deviation limit for each axis in movement
------	---

[Data type] Two-word axis

[Unit of data] Detection unit

[Valid data range] 0 to 99999999

Set the positioning deviation limit in movement for each axis.

1829	Positioning deviation limit for each axis in the stopped state
------	--

[Data type] Word axis

[Unit of data] Detection unit

[Valid data range] 0 to 32767

Set the positioning deviation limit in the stopped state for each axis.

1851	Backlash compensation value used for rapid traverse for each axis
------	---

[Data type] Word axis

[Unit of data] Detection unit

[Valid data range] -9999 to +9999

Set the backlash compensation value for each axis.

3700	#7	#6	#5	#4	#3	#2	#1	#0
							NRF	

[Data type] Bit

NRF The first positioning command by G00 after the serial spindle is switched to Cs axis contouring control performs:

0 : Positioning after returning to the reference position.

1 : Normal positioning

3900	The number of servo axis that interpolates with Cs contour control axis
------	---

[Data type] Byte

[Valid data range] 0 to 8

Set the number of servo axis that interpolates with Cs contour control axis (1st group)

NOTE

Set 0 when there is no servo axis that interpolates with Cs contour control axis.

3901	Loop gain of the servo axis that interpolates with Cs contour control axis during interpolation (High gear)
------	---

3902	Loop gain of the servo axis that interpolates with Cs contour control axis during interpolation (Medium high gear)
------	--

3903	Loop gain of the servo axis that interpolates with Cs contour control axis during interpolation (Medium low gear)
------	---

3904	Loop gain of the servo axis that interpolates with Cs contour control axis during interpolation (Low gear)
------	--

[Data type] Word axis

[Unit of data] 0.01 sec^{-1}

[Valid data range] 0 to 32767

Set the servo loop gain of the servo axis that interpolates with Cs contour control axis on each spindle gear (1st group)

3910	Number of servo axis that interpolates with Cs contour control
------	--

[Data type] Byte axis

[Valid data range] 0 to 8

Set the number of servo axis that interpolates with Cs contour control axis (2nd group)

NOTE

When there is no servo axis or only one servo axis that interpolates with Cs contour control axis, set this parameter to 0.

3911	Loop gain of the servo axis that interpolates with Cs contour control axis during interpolation (High gear)
3912	Loop gain of the servo axis that interpolates with Cs contour control axis during interpolation (Medium high gear)
3913	Loop gain of the servo axis that interpolates with Cs contour control axis during interpolation (Medium low gear)
3914	Loop gain of the servo axis that interpolates with Cs contour control axis during interpolation (Low gear)

[Data type] Word axis

[Unit of data] 0.01 sec^{-1}

[Valid data range] 0 to 32767

Set the servo loop gain of the servo axis that interpolates with Cs contour control axis on each spindle gear (2nd group)

3920	Number of servo axis that interpolates with Cs contour control
------	--

[Data type] Byte axis

[Valid data range] 0 to 8

Set the number of servo axis that interpolates with Cs contour control axis (3rd group)

NOTE

When there is no servo axis or less than three servo axes that interpolates with Cs contour control axis, set this parameter to 0.

3921	Loop gain of the servo axis that interpolates with Cs contour control axis during interpolation (High gear)
3922	Loop gain of the servo axis that interpolates with Cs contour control axis during interpolation (Medium high gear)
3923	Loop gain of the servo axis that interpolates with Cs contour control axis during interpolation (Medium low gear)
3924	Loop gain of the servo axis that interpolates with Cs contour control axis during interpolation (Low gear)

[Data type] Word axis

[Unit of data] 0.01 sec^{-1}

[Valid data range] 0 to 32767

Set the servo loop gain of the servo axis that interpolates with Cs contour control axis on each spindle gear (3rd group)

3930	Number of servo axis that interpolates with Cs contour control
------	--

[Data type] Byte

[Valid data range] 0 to 8

Set the number of servo axis that interpolates with Cs contour control axis (4th group)

NOTE

When there is no servo axis or less than four servo axes that interpolates with Cs contour control axis, set this parameter to 0.

3931	Loop gain of the servo axis that interpolates with Cs contour control axis during interpolation (High gear)
3932	Loop gain of the servo axis that interpolates with Cs contour control axis during interpolation (Medium high gear)
3933	Loop gain of the servo axis that interpolates with Cs contour control axis during interpolation (Medium low gear)
3934	Loop gain of the servo axis that interpolates with Cs contour control axis during interpolation (Low gear)

[Data type] Word axis

[Unit of data] 0.01 sec^{-1}

[Valid data range] 0 to 32767

Set the servo loop gain of the servo axis that interpolates with Cs contour control axis on each spindle gear (4th group)

3940	Number of servo axis that interpolates with Cs contour control
------	--

[Data type] Byte axis

[Valid data range] 0 to 8

Set the number of servo axis that interpolates with Cs contour control axis (5th group)

NOTE

When there is no servo axis or less than five servo axes that interpolates with Cs contour control axis, set this parameter to 0.

3941	Loop gain of the servo axis that interpolates with Cs contour control axis during interpolation (High gear)
3942	Loop gain of the servo axis that interpolates with Cs contour control axis during interpolation (Medium high gear)
3943	Loop gain of the servo axis that interpolates with Cs contour control axis during interpolation (Medium low gear)
3944	Loop gain of the servo axis that interpolates with Cs contour control axis during interpolation (Low gear)

[Data type] Word axis

[Unit of data] 0.01 sec^{-1}

[Valid data range] 0 to 32767

Set the servo loop gain of the servo axis that interpolates with Cs contour control axis on each spindle gear (5th group)

4056	Gear ratio (HIGH)
4057	Gear ratio (MEDIUM HIGH)
4058	Gear ratio (MEDIUM LOW)
4059	Gear ratio (LOW)

[Data type] Word axis

[Unit of data] (Number of motor rotations to one spindle rotation) $\times 100$

[Valid data range] 0 to 32767

Set the gear ratio between spindle and AC spindle motor.

NOTE

For which gear ratio is used in actual spindle operation, it depends on clutch/gear signal (serial spindle) CTH1A, CTH2A.

4069	Position gain at Cs contour control (High gear)
4070	Position gain at Cs contour control (Medium High gear)
4071	Position gain at Cs contour control (Medium Low gear)
4072	Position gain at Cs contour control (Low gear)

[Data type] Word axis

[Unit of data] 0.01 sec^{-1}

[Valid data range] 0 to 32767

Set the position gain at Cs contour control.

NOTE

For which position gain is used in actual spindle operation, it depends on clutch/gear signal (serial spindle) CTH1A, CTH2A.

4135	Grid shift value at Cs contour control
------	--

[Data type] Two-word

[Unit of data] 1 pulse unit (360000 p/rev)

[Valid data range] -360000 to +360000

Set the number of pulses from an issue of one-rotation signal to the machine zero point in Cs contour control.

Alarm and message

Number	Message	Description
194	SPINDLE COMMAND IN SYNCHRO-MODE	A contour control mode, spindle positioning (Cs-axis control) mode, or rigid tapping mode was specified during the serial spindle synchronous control mode. Correct the program so that the serial spindle synchronous control mode is released in advance.
197	C-AXIS COMMANDED IN SPINDLE MODE	The program specified a movement along the Cs contour control axis when the signal CON(G027#7) was off. Correct the program, or consult the PMC ladder diagram to find the reason the signal is not turned on.
751	First spindle alarm detection (AL-XX)	In a system with serial spindles attached, this is a warning alarm message that indicates an alarm on the spindle amplifier side to be displayed on the CRT of the NC. An alarm on the spindle amplifier side is displayed on the spindle amplifier, as AL-XX (where XX represents a number). This alarm number (XX) is displayed by latching the spindle alarm number detected by the CNC as the cause of this alarm.
752	FIRST SPINDLE MODE CHANGE FAULT	This alarm is generated if the system does not properly terminate a mode change. The modes include the Cs contouring, spindle positioning, rigid tapping, and spindle control modes. The alarm is activated if the spindle control unit does not respond correctly to the mode change command issued by the NC.

Warning**WARNING**

In the spindle contour control mode, do not switch the spindle gears. When the gears need to be changed put the system in the spindle speed control mode first.

Note**NOTE**

In the T series machines, the spindle contour control function and the spindle positioning function cannot be used at the same time. If both functions are specified simultaneously, the spindle positioning function takes precedence.

Reference item

FANUC SERVO AMPLIFIER <i>α</i> series DESCRIPTIONS (B-65162E)	11.6	Cs Contour Control Function
FANUC AC SPINDLE MOTOR <i>α</i> series PARAMETER MANUAL (B-65160E)	2.4	Cs Contour Control
FANUC AC SPINDLE MOTOR <i>αi</i> series PARAMETER MANUAL (B-65280EN)	2.4	Cs Contour Control

9.9.2 Cs Axis Coordinate Setup Function

The machine loses its current position when the serial spindle is switched from spindle rotation control to Cs contour control.

Setting the Cs axis coordinate setup request signal CSFI <G274#4> to '1' enables the machine to set up its current position without making a reference position return.

NOTE

This function stays in effect until the power is turned off after the power is turned on and a reference position return of the Cs contour axis is made.

This function is part of the "Cs axis contour control function."

Setting

This function is put in effect by setting the CSF parameter (bit 2 of parameter No. 3712) and the CSPTRE parameter (bit 5 of parameter No. 4353) to 1.

(Using this function requires resetting the RFCHK3 parameter (bit 7 of parameter No. 4016) to 0.)

The M code for setting the Cs axis contour control coordinate setup request signal CSFI <G274#4> to '1' should be set up as buffer inhibit M codes (parameter Nos. 3411 to 3432).

Cs axis coordinate setup procedure

- (1) Trigger the M code to put the machine in the Cs contour control mode.
- (2) Make sure that the Cs axis origin setup state signal CSPENA is '1', and set the Cs axis coordinate setup request signal CSFI1 <G274#4> to '1'.
- (3) The absolute, relative, and machine coordinates of the Cs axis are incremented for coordinate system setup.
- (4) Once the coordinate system is set up, the reference position setup signal ZRFx <F120#0 to F120#3> becomes '1'. So, reset the Cs axis coordinate setup request signal CSFI1 <G274#4> to '0'.
- (5) Perform FIN processing for the M code.

If an attempt to set up Cs axis coordinates fails

If an attempt to set up Cs axis coordinates fails, the P/S alarm 5346 is issued.

Also, the Cs axis coordinate setup alarm signal CSFO1 <F274#4> becomes '1'. So, reset the Cs axis coordinate setup request signal CSFI1 <G274#4> to '0'.

Resetting the Cs axis coordinate setup request signal CSFI1 <G274#4> to '0' causes the Cs axis coordinate setup alarm signal CSFO1 <F274#4> to be reset to '0'.

The following conditions can make the attempt to setup the Cs axis coordinates fail.

- The Cs axis origin setup state signal CSPENA is '0'.
- The Cs axis is under synchronization control.
- The machine is brought to an emergency stop during coordinate setup.
- The Cs axis motor is de-energized during coordinate setup (such as servo alarm or servo off).
- Bidirectional pitch error compensation is in effect for the Cs axis.

Clearing P/S alarm 5346

P/S alarm 5346 can be cleared only after the reference position of the Cs axis has been set up.

If P/S alarm 5346 has been issued, perform a manual reference position return for the Cs axis. Once the reference position has been setup, a reset clears P/S alarm 5346.

In addition, once the machine has exited the Cs contour control mode, a reset clears P/S alarm 5346.

Sequence (timing chart)

When Cs axis coordinate setup is normally completed:

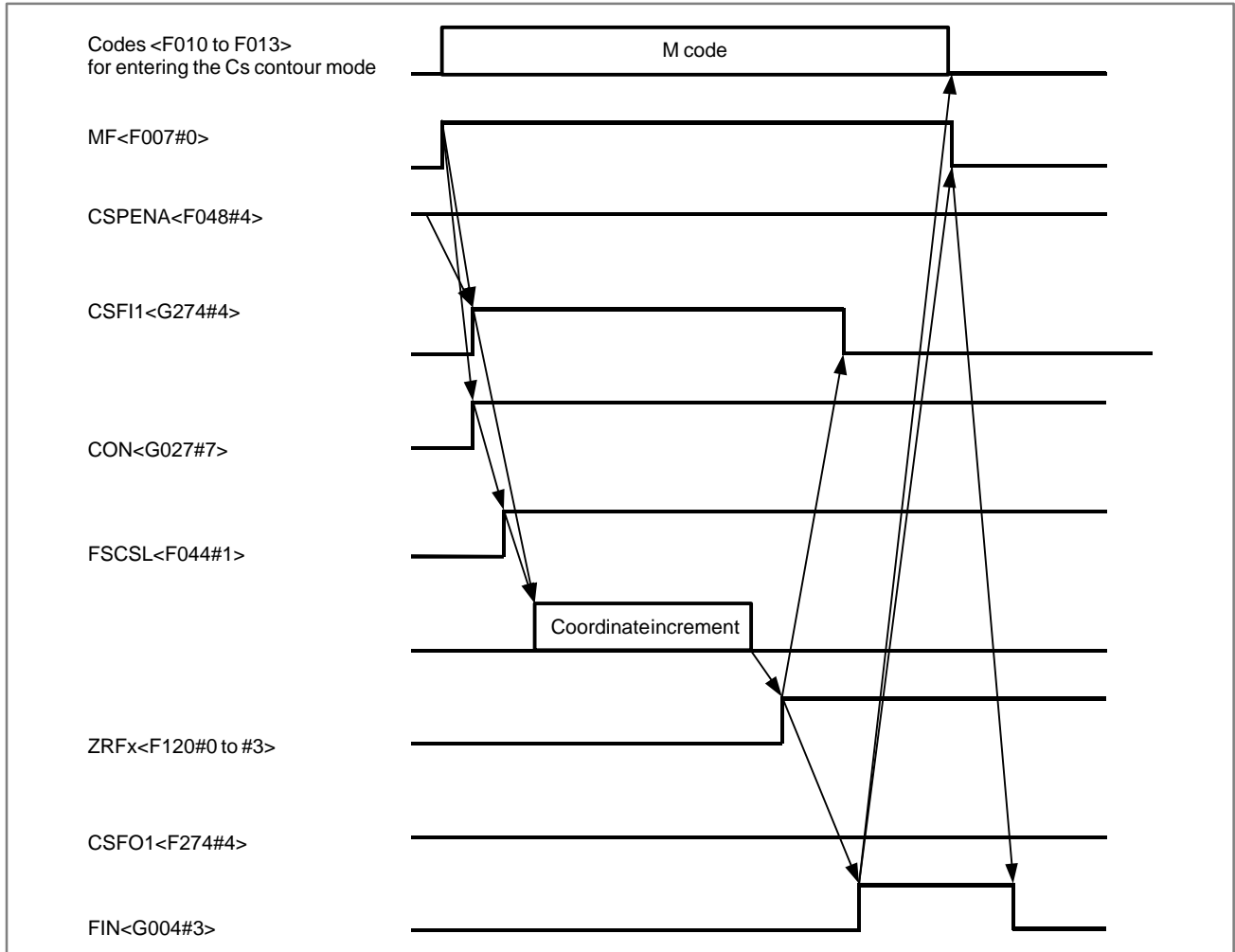

The Cs axis coordinate setup function is valid only during Cs contour mode. If the Cs axis coordinate setup request signal CSFI1 <G274#4> is set to '1' during any other mode, it is ignored.

If an attempt to set up Cs axis coordinates fails (because of suspension by an emergency stop, for example)

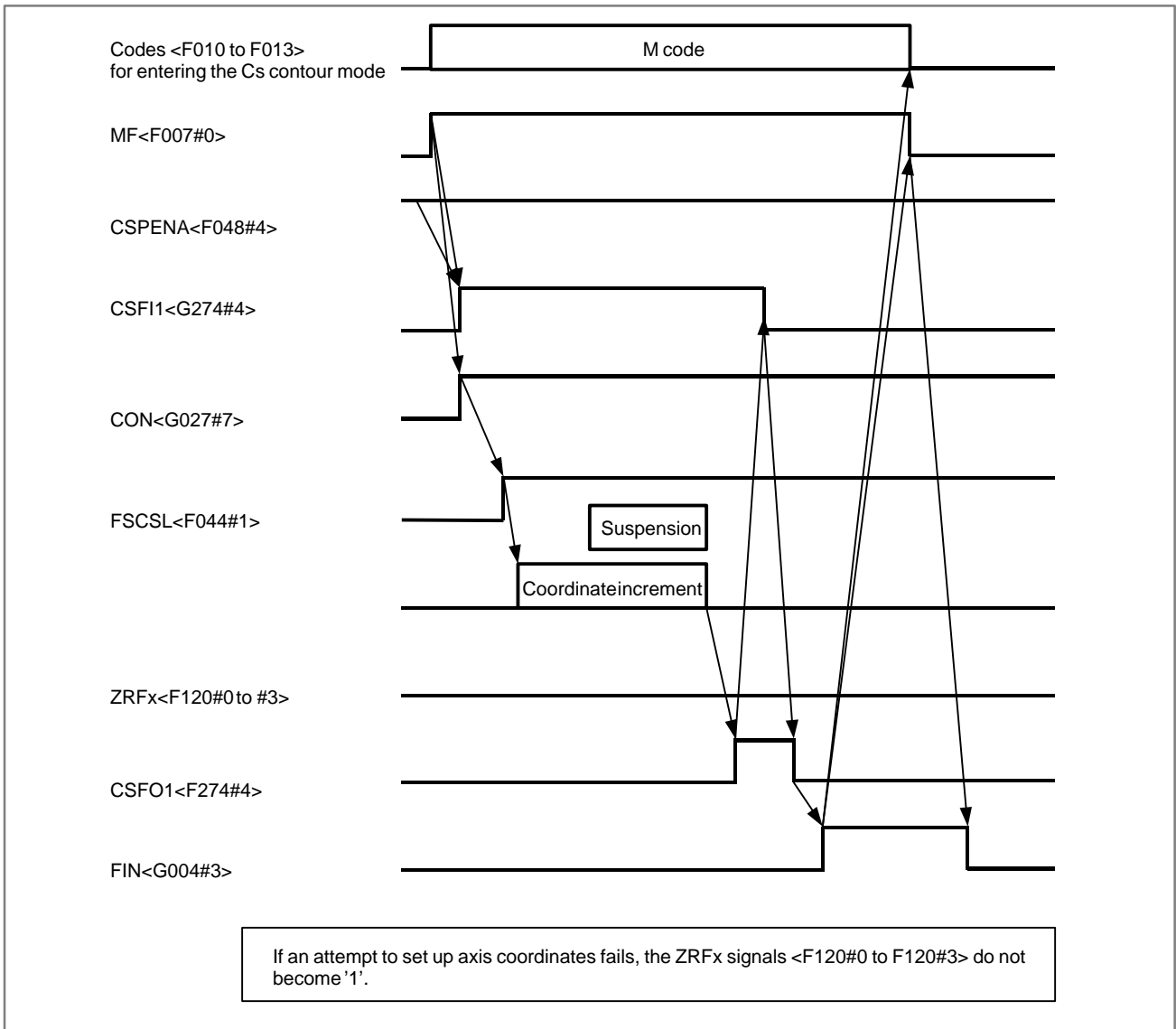

Parameter

	#7	#6	#5	#4	#3	#2	#1	#0
1005								ZRN

[Data type] Bit

ZRN If no reference position return has been made, an attempt to start automatic operation:

0 : Is responded with an alarm (P/S 224).

1 : Is responded with no alarm.

To use the Cs axis coordinate setup function, it is recommended to specify ZRN = 0.

	#7	#6	#5	#4	#3	#2	#1	#0
3700							NRF	

[Data type] Bit

NRF Once the Cs contour control mode has been entered, the first positioning command G00:

0 : Makes a reference position return.

1 : Performs normal positioning.

To use the Cs axis coordinate setup function, it is recommended to specify NRF = 1.

	#7	#6	#5	#4	#3	#2	#1	#0
3712						CSF		

[Data type] Bit

CSF If the origin has been set up, automatic setting of the machine and work coordinates according to the machine position of the spindle during Cs contour control mode is:

0 : Disabled.

1 : Enabled.

	#7	#6	#5	#4	#3	#2	#1	#0
4353			CSP TRE					

[Data type] Bit axis

CSP TRE Cs axis position data transfer is:

0 : Disabled.

1 : Enabled.

To use this function, reset the RFOHK3 parameter (bit 7 of parameter No. 4016) to 0.

Signal

**Cs axis coordinate setup
request signal
CSFI1 <G274#4>**

[Classification] Input signal

[Function] The Cs axis coordinate setup function is executed.

[Operation] If this signal is "1", the control unit behaves as follows:

If the signal is "1" during Cs contour control mode, the work and machine coordinates are set up according to the machine position of the Cs axis.

If this signal is "0", the control unit behaves as follows:

The Cs axis coordinate setup alarm signal CSFO1 <F274#4> is reset to '0'.

Cs axis coordinate setup alarm signal CSFO1 <F274#4>

[Classification] Output signal

[Function] This signal indicates that Cs axis coordinate setup has not normally been completed.

[Output condition] The signal becomes '1' under the following condition:

- Cs axis coordinate setup is not normally completed.

The signal becomes '0' under the following conditions:

- The Cs contour control mode is exited.
- The corresponding Cs axis coordinate set request signal CSFI1 <G274#4> becomes '0'.

Cs axis origin setup status signal CSPENA <F048#4>

[Classification] Output signal

[Function] This signal indicates that it is possible to perform Cs axis coordinate setup processing.

[Output condition] The signal becomes '1' under the following condition:

- A reference position return is normally completed during Cs contour control mode.

The signal becomes '0' under the following condition:

- A spindle alarm is detected or the spindle motor rotates faster than the maximum allowable rotation speed (No. 4020).

Signal address

	#7	#6	#5	#4	#3	#2	#1	#0
G274				CSFI1				
F048				CSPENA				
F274				CSFO1				

Alarm and message

Number	Message	Description
5346	RETURN TO REFERENCE POINT	<p>The Cs coordinate setup function was suspended. Make a manual reference position return.</p> <ol style="list-style-type: none"> 1. An attempt was made to perform Cs axis coordinate setup for the Cs axis for which CSPEN = '0'. 2. No position information has been transferred from the spindle amplifier. 3. The machine was brought to an emergency stop during coordinate setup. 4. Cs axis coordinate setup was started for the Cs axis for which bidirectional pitch error compensation was in effect. 5. Cs axis coordinate setup was started for the Cs axis whose servo was off.

Caution

CMR

If the CMR is greater than 1 (parameter No. 1820 > 2), the Cs axis may move through several pulses' worth of distance. This is intended to align the Cs axis machine position to the least command increment. (1 to 9 pulses in terms of detection units if CMR = 10.)

Stored pitch error compensation

If the Cs axis machine position meets the following condition, the Cs axis moves by a pitch error compensation during coordinate setup.
 $|\text{Nearest pitch compensation point} - \text{Cs axis machine position}| < \text{pitch error compensation}$

Example:

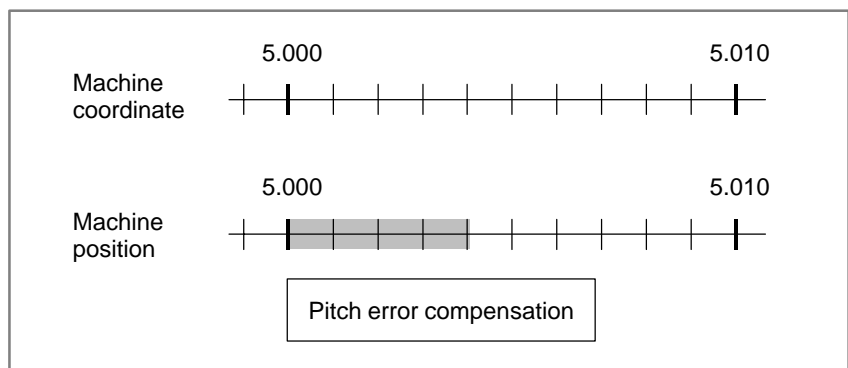

Assuming that a pitch error compensation of +0.004 is specified for a pitch error compensation interval of 10.000 degrees and a machine coordinate of 5.000, the Cs axis will not stop at a machine position of 5.000 to 5.003.

Machine coordinate 4.999 → 5.000 → 5.001
 Machine position 4.999 → 5.004 → 5.005

Whereas the Cs axis may stop at a machine position of 5.000 to 5.003 if the Cs contour control mode is entered after rotation in the spindle speed control mode.

In this case, the relationship between the machine coordinates and machine position is adjusted by shifting the machine position of the Cs axis by a pitch error compensation.

Synchronization control

If the Cs axis coordinate setup request signal CSFI1 <G274#4> is set to '1' during synchronization control, P/S alarm 5346 occurs.

Be sure to set up the coordinates before starting synchronization control.

Manual handle interrupt

Manual handle interrupts are disabled during Cs axis coordinate setup.

External machine coordinate system shifting

External machine coordinate system shifting is disabled for the axis that is undergoing Cs axis coordinate setup.

Mirror image

The mirror image signals MI1 to MI4 <G106> and a mirror image based on the MIRx parameter <bit 0 of parameter No. 0012> are disabled for the Cs axis coordinate setup function.

Bidirectional pitch error compensation

This function does not support bidirectional pitch error compensation. P/S alarm No. 5346 is issued if an attempt is made to perform Cs axis coordinate setup for the axis for which bidirectional pitch error compensation is in effect.

Reference item

FANUC AC SPINDLE MOTOR <i>α</i> / <i>β</i> <i>i</i> series PARAMETER MANUAL (B-65280EN)	2.4	Cs Contour Control
---	-----	--------------------

9.10 MULTI-SPINDLE CONTROL

General

In addition to the conventional (first) spindle, maximum four additional (second, third, and fourth) spindles can be controlled. These additional spindles allow two-stage gear changes. A single S code is used to command to any of these spindles. The spindle to be commanded by S code is determined by a signal from the PMC. The second, third, and fourth spindle can change gears in 2 stages.

Also, the maximum clamp spindle speed can be individually set to each spindle to clamp the spindle speed of each spindle (set by parameters No. 3772, 3802, 3822, and 3850).

When the second spindle is used, a second position coder interface channel is added. Selection between 1st position coder to 4th position coder is made by a signal from PMC. (The conventional and additional position coders are referred to as the first position coder and second position coder, respectively, throughout the remainder of this discussion.)

When serial spindles are used as the third and fourth spindles, two position coder interfaces can be added. (The position coders will be referred to as the third position coder and fourth position coder.)

The spindle serial output option is required to use multi-spindle control.

If the third and fourth spindles (serial spindles) are needed, specify the third/fourth spindle serial output function.

Difference in multi-spindle control between the M and T series

- For the M series, multi-spindle control is possible only when spindle gear selection type T is selected (when the constant surface speed control option is provided, or when GTT (bit 4 of parameter No. 3706) is set to 1).
- For the M series, rigid tapping spindle selection signals RGTSP1, RGTSP2, and RGTSP3 (G061#4, #5, and #6, when bit 7 of parameter No. 5200 is set to 1) cannot be used. For details of rigid tapping, see Section 9.11.
- When two-path control is performed with the M series, spindle commands and position coder feedback signals cannot be changed between the paths (spindle command select signals SLSPA and SLSPB <G063 #2 and #3>, and spindle feedback select signals SLPCA and SLPCB <G064 #2 and #3> are not available).

Control

Two multi-spindle control methods are available. Type A allows the SIND function (controlling the spindle motor speed based on the PMC) to be used only for the first spindle. Type B allows the SIND function to be used for each of the four spindles independently.

Basic control (Common to TYPE-A and TYPE-B)

An S command is sent as a speed command to each spindle selected, using a spindle selection signal (SWS1 to SWS4 <G027#0-#2>, <G026#3>). Each spindle rotates at the specified speed. If a spindle is not sent a spindle selection signal, it continues to rotate at its previous speed. This allows the spindles to rotate at different speeds at the same time.

Each spindle also has a spindle stop signal (*SSTP1 to *SSTP4 <G027#3-#5>, <G026#6>) to stop its rotation; an unused spindle can still be stopped.

There is a spindle enable signal to control each spindle; ENB <F001#4> controls the first spindle, while ENB2 to ENB4 <F038#2, #3>, <F039#1> control the second and third spindles, respectively.

The PMC signal PC2SLC to PC4SLC <G028#7>, <G0260, #1> is used to select between the first to fourth position coders.

Multi-spindle control (TYPE-A)

When parameter MSI (No. 3709#2)=0, TYPE-A is used.

When the first spindle is selected with the SWS1 signal, the SIND signal <G033#7> is used to determine whether the spindle analog voltage is controlled by the PMC or CNC; then signals R01I to R12I <G0033#3 to G0032#0> are used to set that spindle’s analog voltage. These signals do not affect the second to fourth spindles.

The PMC-based polarity (rotation direction) control signals SGN and SSIN <G033#5,#6> will function for any spindle selected by SWS1 to SWS4.

The concept of Type A multi-spindle control is outlined below.

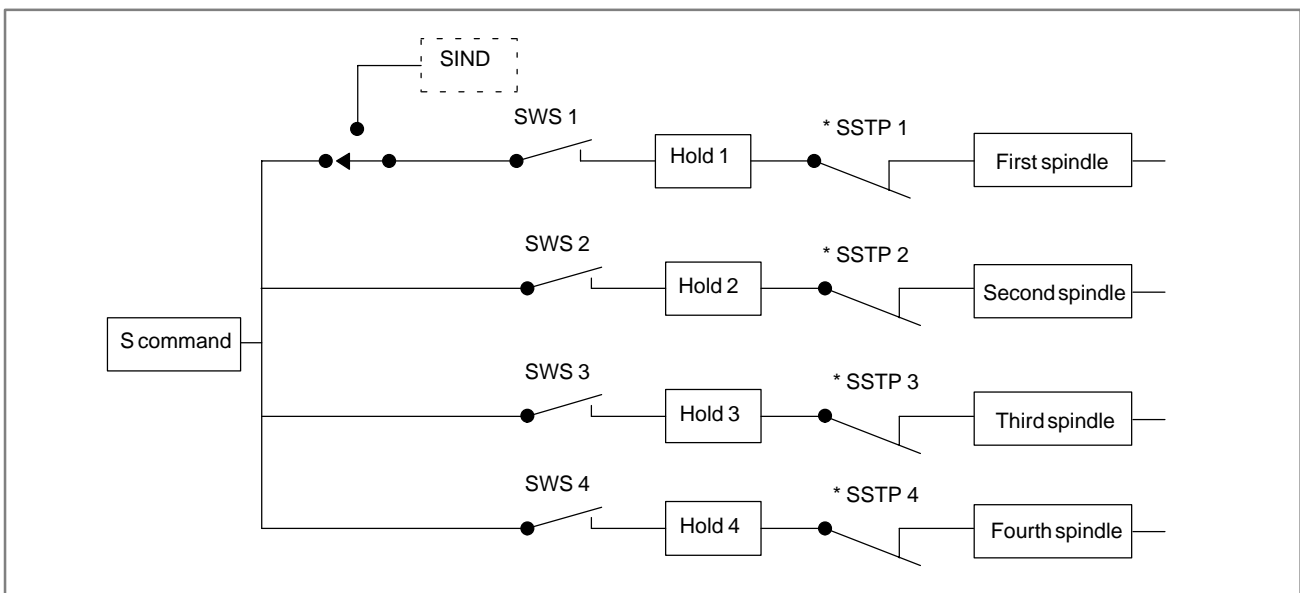

Multi-spindle control (TYPE-B)

Select Type B control by setting parameter MSI No. 3709#2 to “1”.

Each spindle has its own SIND, SSIN and SGN signals. Each of these signals functions regardless of selection state of the spindle selection signals (SWS1 to SWS4).

When either the spindle selection signals (SWS1 to SWS4) or the SIND signal for the first, second, third, or fourth spindle is set to “1”, the polarity control signals SSIN, SGN will function.

The concept of Type B multi-spindle control outlined below.

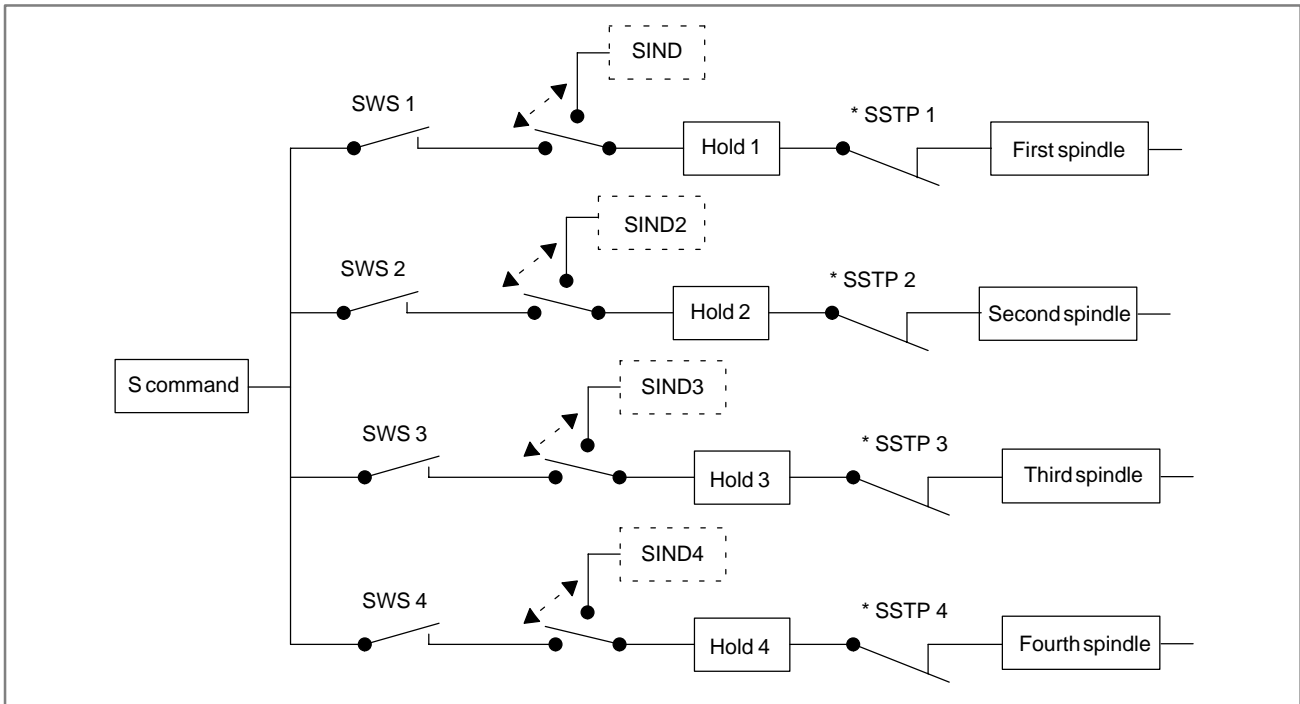

Spindles to be controlled

In multi-spindle control, the first spindle is the first serial spindle, the second spindle is the second serial spindle, and the third spindle is an analog spindle.

Alternatively, configure the third and fourth spindles by the third and fourth serial spindles respectively.

A configuration is possible which does not connect the second or third spindles.

The fourth spindle can be connected only when the third spindle is connected.

Connection of spindle

Spindle configuration when multi-spindle control is used:

Necessary option and parameter	<ul style="list-style-type: none"> · Multi-spindle control · Spindle serial output · Parameter SS2 (No. 3701#4) = 1 (to use second spindle) · Spindle analog output (to use third spindle)
Connection of each spindle	<p>First spindle (JA7B) → Connect on JA41 (CNC main CPU board).</p> <p>Second spindle (JA7B) → Connect on JA7A (first spindle control unit).</p> <p>Third spindle → Connect on JA40 (CNC main CPU board).</p>
Connection of each position coder	<p>First position coder: Feedback information obtained by position coder or equivalent sensor connected to first spindle control unit is fed to CNC via serial interface.</p> <p>Second position coder: Feedback information obtained by position coder or equivalent sensor connected to second spindle control unit is fed to CNC via serial interface through 1st spindle control unit</p> <p>Note) When second spindle is not connected, second position coder cannot be used.</p>

For detailed information about serial spindle connection, refer to the manuals on the serial spindles.

Relationship with other optional functions

• Constant surface speed control

The control function for keeping the surface speed constant can be used with any of the four spindles, if the spindle speed is within the range allowable for this function. When the position coder is required, it can be installed on the 1st, 2nd, 3rd, or 4th spindle. The spindle selection signal (SWS 1–4) for the spindle must stay set at “1” during machining using this function.

• Spindle speed fluctuation detection

If multi-spindle control is combined, multiple position coders can be selected. To carry out spindle speed fluctuation detection, select the first spindle (first position coder). Monitor the states of the second, third, and fourth position coder selection signals (PC2SLC, PC3SLC, PC4SLC) and spindle selection signals (SWS1 to SWS4). The spindle speed fluctuation detection cannot be executed with the second, third, or fourth position coder.

• Actual spindle speed output

The actual spindle speed output function conveys speed information obtained from the position coder specified by the second, third, and fourth position coder selection signals (PC2SLC, PC3SLC, and PC4SLC) to the PMC.

When the parameter HSO (No. 3709#5)=1, the difference of the feedback pulses between the 1st and 2nd position coder can be output irrespective of the state of 2nd position coder selection signal (PC2SLC).

- **Spindle positioning or Cs contour control**
When the spindle motor is used for positioning, as in the case of spindle positioning or Cs contour control, the first spindle will allow function as the positioning spindle. Switching to the positioning mode and positioning command are possible irrespective of the state of the selection signal of the first spindle (SWS1). This means that the first spindle cannot be controlled as a spindle in positioning mode, but the second to fourth spindles can be controlled as usual.
- **Polygon turning (T series)**
Polygon turning rotates a tool axis in phase with the spindle. To perform polygon turning when multi-spindle control is issued, select the spindle and the position coder associated with the spindle.
(First to fourth position coders can be selected.)
- **Spindle synchronization, polygon turning between spindles, simplified synchronization control**
During spindle synchronization, polygon turning between spindles or simplified synchronization control, the second spindle operates in phase with the first spindle. Multi-spindle control for the first, third, and fourth spindles can be used during synchronization control, but multi-spindle control for the second spindle is disabled.
- **Rigid tapping**
Rigid tapping can be performed by selecting one spindle from the first to third spindles by means of the spindle selection signals (SWS1 to SWS3). If the third spindle is configured as an analog spindle, rigid tapping cannot be performed with the third spindle. Rigid tapping cannot be performed with the fourth spindle. There are certain restrictions:
 - Set the SWS 1 to 3 signals before directing rigid tapping;
 - Do not switch the SWS 1 to 3 signals during rigid tapping; and
 - Use the appropriate ENB signal (either ENB, ENB2, or ENB3) for the selected spindle as the ENB signal for the rigid tapping PMC sequence.

The spindles not used for rigid tapping can be rotated at a speed specified before rigid tapping starts, or can be stopped.
- **Two-path control option**
Refer to 9.4 “Spindle Control for Two-path Lathe”.

Signal

Spindle Selection Signal SWS1, SWS2, SWS3, SWS4 <G027#0, #1, #2>, <G026#3>

[Classification] Input signal

[Function] Controls whether S command specified to the NC is output to the spindle or not in multi-spindle.

SWS1 1 : Outputs a speed command to the first spindle.
0 : Outputs no speed command to the first spindle.

SWS2 1 : Outputs a speed command to the second spindle.
0 : Outputs no speed command to the second spindle.

- SWS3** 1 : Outputs a speed command to the third spindle.
0 : Outputs no speed command to the third spindle.
- SWS4** 1 : Outputs a speed command to the fourth spindle.
0 : Outputs no speed command to the fourth spindle.

**Individual spindle stop
signal *SSTP1, *SSTP2,
*SSTP3, SSTP4 <G027#3,
#4, #5>, <G026#6>**

[Classification] Input signal

[Function] Effective only to multi-spindle, each spindle can be stopped by this signal.

- *SSTP1** 1 : Does not set 0 min⁻¹ for output to the first spindle.
0 : Sets 0 min⁻¹ for output to the first spindle.
- *SSTP2** 1 : Does not set 0 min⁻¹ for output to the second spindle.
0 : Sets 0 min⁻¹ for output to the second spindle.
- *SSTP3** 1 : Does not set 0 min⁻¹ for output to the third spindle.
0 : Sets 0 min⁻¹ for output to the third spindle.
- *SSTP4** 1 : Does not set 0 min⁻¹ for output to the fourth spindle.
0 : Sets 0 min⁻¹ for output to the fourth spindle.

Gear select signal

**GR21 <G029#0>
GR31 <G029#2>
GR41 <G031#4>**

[Classification] Input signal

[Function] Gear selection signals for second to fourth spindle when multi-spindle is equipped (2-stage). Use GR1 and GR2 <G028#1, #2> for the 1st spindle and up to 4-stage gears can be used.

- GR21** 1 : Selects the second-stage gear for the second spindle.
0 : Selects the first-stage gear for the second spindle.
- GR31** 1 : Selects the second-stage gear for the third spindle.
0 : Selects the first-stage gear for the third spindle.
- GR41** 1 : Selects the second-stage gear for the fourth spindle.
0 : Selects the first-stage gear for the fourth spindle.

**2nd/3rd/4th position
coder selection signal**
PC2SLC <G028#7>
PC3SLC <G026#0>
PC4SLC <G026#1>

[Classification] Input signal

[Function] These signals select the position coder of the serial spindle used for multi-spindle control. The 3rd and 4th position coder selection signals can be selected only when PCS (bit 6 of parameter No.3704), which selects whether to use the third and fourth position coders, is set to 1.

To select a position coder, enter the signals as follows.

Position coder to be selected	PC2SLC	PC3SLC	PC4SLC
First position coder	0	0	0
Second position coder	1	0	0
Third position coder	0	1	0
Fourth position coder	0	0	1

If PC2SLC, PC3SLC, and PC4SLC are set to 1, the position coder of a lower number is selected.

When the second, third, or fourth position coder is not installed, do not switch this signal. Always set "0" for first position coder.

Spindle enable signal
ENB2<F038#2>
ENB3<F038#3>
ENB4<F039#1>

[Classification] Output signal

[Function] These signals inform PMC of whether or not to perform output to the second to fourth spindles in multi-spindle control.

The signals are used as a condition to stop the analog spindle, and are also used for a PMC ladder sequence that is associated with rigid tapping. (See Section 9.11.)

[Output condition] ENB2 1 : Enables output of command other than 0 to the second spindle control unit.
0 : Outputs 0 to the second spindle control unit.

ENB3 1 : Enables output of command other than 0 to the third spindle control unit.
0 : Outputs 0 to the third spindle control unit.

ENB4 1 : Enables output of command other than 0 to the fourth spindle control unit.
0 : Outputs 0 to the fourth spindle control unit.

Spindle control signal by PMC

First spindle	SIND, SSIN, SGN <G033#7, #6, #5> R01I to R12I <G032#0 to G033#3>
Second spindle	SIND2, SSIN2, SGN2 <G035#7, #6, #5> R01I2 to R12I2 <G034#0 to G035#3>
Third spindle	SIND3, SSIN3, SGN3 <G037#7, #6, #5> R01I3 to R12I3 <G036#0 to G037#3>
Fourth spindle	SIND4, SSIN4, SGN4 <G273#7, #6, #5> R01I4 to R12I4 <G272#0 to G273#3>

[Classification] Input signal

[Function] The spindle motor of each spindle can be controlled by issuing commands from the PMC. The speed command and polarity (rotation direction) of the spindle motor can be controlled. Usually, CNC commands are used to specify a speed and polarity. By using these signals, whether commands issued from the CNC or PMC are to be used for this control can be selected. Even when multi-spindle control is not being used, the signals can be used to control the second to fourth spindles.

When multi-spindle control is being used, and TYPE-A is selected (bit 2 (MSI) of parameter No. 3709 is set to 0), the signals for the second to fourth spindles cannot be used.

For details of each signal, see Section 15.4.

Signal address

	#7	#6	#5	#4	#3	#2	#1	#0
G026		*SSTP4			SWS4		PC4SLC	PC3SLC
G027			*SSTP3	*SSTP2	*SSTP1	SWS3	SWS2	SWS1
G028	PC2SLC					GR2	GR1	
G029		*SSTP				GR31		GR21
G031				GR41				
G032	R08I	R07I	R06I	R05I	R04I	R03I	R02I	R01I
G033	SIND	SSIN	SGN		R12I	R11I	R10I	R09I
G034	R08I2	R07I2	R06I2	R05I2	R04I2	R03I2	R02I2	R01I2
G035	SIND2	SSIN2	SGN2		R12I2	R11I2	R10I2	R09I2
G036	R08I3	R07I3	R06I3	R05I3	R04I3	R03I3	R02I3	R01I3
G037	SIND3	SSIN3	SGN3		R12I3	R11I3	R10I3	R09I3
G272	R08I4	R07I4	R06I4	R05I4	R04I4	R03I4	R02I4	R01I4
G273	SIND4	SSIN4	SGN4		R12I4	R11I4	R10I4	R09I4
	#7	#6	#5	#4	#3	#2	#1	#0
F038					ENB3	ENB2		
F039							ENB4	

Parameter

The parameters for the 1st spindle and the 1st position coder are the same as usual. This section describes the parameters which are added by the multi-spindle control function.

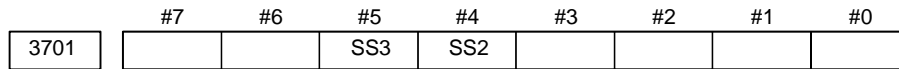

[Data type] Bit

SS2 In serial spindle control, the second spindle is:
 0 : Not used.
 1 : Used.

NOTE
 This parameter is valid, when the spindle serial output option is provided and parameter ISI(bit 1 of parameter No.3701)is 0.

- 1 Confirmation of connection of the second serial spindle amplifier, and communication with it
- 2 Control of the second spindle during asynchronous control (SIND2)

When this parameter is set, it is also necessary to set the serial spindle parameter for the second spindle.

SS3 In serial spindle control, the third spindle is:
 0 : Not used.
 1 : Used.

NOTE
 This parameter is valid, single-path control and the spindle output option and the three-spindle serial output option are provided.

Parameter setting			Serial spindles to be used
SS4 (No.3704#1)	SS3 (No.3701#5)	SS2 (No.3701#4)	
0	0	0	First spindle only
0	0	1	First and second spindles
0	1	0	First and third spindles
0	1	1	First to third spindles
1	1	0	First, third, and fourth spindles
1	1	1	First to fourth spindles

NOTE

- 1 To connect a serial spindle as the third or fourth spindle, the function of three/four-spindle serial output is required.
- 2 The fourth serial spindle can be used just in Series 16i/160i/160is.

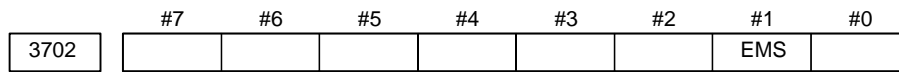
**[Data type] Bit**

EMS Multi-spindle control is

0 : Used

1 : Not used

NOTE

If the multi-spindle control function is not required for one path in two-path control, set this parameter for the path to which the multi-spindle control function need not be applied.

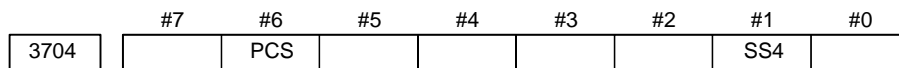
**[Data type] Bit**

SS4 Under serial spindle control, the fourth serial spindle is:

0 : Not used.

1 : Used.

Bit 5 (SS3) and bit 4 (SS2) of parameter No. 3701 and this parameter specify the number of spindles to be connected.

See the table added to the description of bit 5 (SS3) and bit 4 (SS2) of parameter No. 3701.

NOTE

1 To use the fourth serial spindle, the third serial spindle is required.

2 The fourth serial spindle can be used just in Series 16i/160i/160is.

PCS If the third or fourth serial spindle is connected under multi-spindle control, the third or fourth position coder selection signal (PC3SLC, PC4SLC <G026 bits 0 and 1>) is:

0 : Not used.

1 : Used.

NOTE

If the position coder feedback is exchanged between paths under multipath control of T series (spindle feedback selection signals SLPCA and SLPCB <G064 bits 2 and 3>), set this parameter to the same setting for the paths.

The fourth serial spindle can be used just in Series 16i/160i/160is.

	#7	#6	#5	#4	#3	#2	#1	#0
3706					PCS		PG2	PG1
			GTT				PG2	PG1

[Data type] Bit

PG2, PG1 Gear ration of spindle to first position coder
For the setting, see the description of parameter No.3707.

PCS When multi-spindle control is applied to two tool posts in two-path control, this parameter specifies whether the position coder feedback signal from the other tool post is selectable, regardless of the state of the PC2SLC signal (bit 7 of G028/bit 7 of G1028) of the other tool post:

0 : Not selectable.

1 : Selectable. (To select a position coder for the other tool post, the SLPCA signal (bit 2 of G064) and the SLPCB signal (bit 3 of G064) are used.)

NOTE

Multi-spindle control based on the same serial spindle must be applied to both tool posts.

Refer to 9.4 for details.

GTT Selection of a spindle gear selection method

0 : Type M.

1 : Type T.

NOTE

1 Type M:

The gear selection signal is not entered. In response to an S command, the CNC selects a gear according to the speed range of each gear specified beforehand in parameters. Then the CNC reports the selection of a gear by outputting the gear selection signal. The spindle speed corresponding to the gear selected by the gear selection signal is output.

Type T:

The gear selection signal is entered. The spindle speed corresponding to the gear selected by this signal is output.

2 When the constant surface speed control option is selected, type T is selected, regardless of whether this parameter is specified.

3 When type T spindle gear switching is selected, the following parameters have no effect:

No. 3705#2 SGB, No. 3751, No. 3752, No. 3705#3 SGT, No. 3761, No. 3762, No. 3705#6 SFA, No. 3735, No. 3736
However, parameter No. 3744 is valid.

	#7	#6	#5	#4	#3	#2	#1	#0
3707			P42	P41	P32	P31	P22	P21

PG2, PG1 (Bits 1 and 0 of parameter No.3702)

Gear ratio of spindle to first position coder

P22, P21 Gear ratio of spindle to second position coder

P32, P31 Gear ratio of spindle to third position coder

P42, P41 Gear ratio of spindle to fourth position coder

Magnification	PG2, P22, P32, P42	PG1, P21, P31, P41
× 1	0	0
× 2	0	1
× 4	1	0
× 8	1	1

$$\text{Magnification} = \frac{\text{(Number of spindle revolutions)}}{\text{(Number of position coder revolutions)}}$$

NOTE

- 1 Second to fourth position coders are enabled when the multi-spindle control option is selected.
- 2 Third and fourth position coders are enabled when the bit 6 (PCS) of parameter No. 3704 is set to 1.

	#7	#6	#5	#4	#3	#2	#1	#0
3709						MSI		

MSI In multi-spindle control, the SIND signal is valid

0 : Only when the first spindle is valid (SIND signal for the 2nd, 3rd spindle becomes ineffective)

1 : For each spindle irrespective of whether the spindle is selected (Each spindle has its own SIND signal).

3772	Maximum spindle speed
------	-----------------------

[Data type] Word

[Unit of data] min⁻¹

[Valid data range] 0 to 32767

This parameter sets the maximum spindle speed.

When a command specifying a speed exceeding the maximum speed of the spindle is specified, or the speed of the spindle exceeds the maximum speed because of the spindle speed override function, the spindle speed is clamped at the maximum speed set in the parameter.

WARNING

- 1 When 0 is set in this parameter, the speed of the spindle is not clamped.
- 2 When spindle speed command control is applied using the PMC, this parameter has no effect, and the speed of the spindle is not clamped.

NOTE

- 1 When the constant surface speed control option is selected, the spindle speed is clamped at the maximum speed, regardless of whether the G96 mode or G97 mode is specified.
- 2 When the multi-spindle control option is selected, set the maximum speed for each spindle in the following parameters:
 Parameter No. 3772: Sets the maximum speed for the first spindle.
 Parameter No. 3802: Sets the maximum speed for the second spindle.
 Parameter No. 3822: Sets the maximum speed for the third spindle.

3802

Maximum speed of the second spindle

[Data type] Word**[Unit of data]** min^{-1} **[Valid data range]** 0 to 32767

Parameter sets the maximum speed for the second spindle.

When a command specifying a speed exceeding the maximum speed of the spindle is specified, or the speed of the spindle exceeds the maximum speed because of the spindle speed override function, the spindle speed is clamped at the maximum speed set in the parameter.

WARNING

- 1 When 0 is set in this parameter, the setting of parameter No. 3772 for the first spindle is used.
 When 0 is set in parameter No. 3772, the spindle speed is not clamped.
- 2 When spindle speed command control is applied using the PMC, this parameter has no effect, and the spindle speed is not clamped.

NOTE

- 1 This parameter is valid when the multi-spindle control option is selected.
- 2 When the constant surface speed control option is selected, the spindle speed is clamped at the specified maximum speed, regardless of whether the G96 mode or G97 mode is specified.

3811	Maximum spindle speed for gear 1 of the second spindle
3812	Maximum spindle speed for gear 2 of the second spindle

[Data type] Word

[Unit of data] min^{-1}

[Valid data range] 0 to 32767

Set the maximum spindle speed for each gear of the second spindle.

NOTE

These parameters are used only with multi-spindle control.

3820	Data for adjusting the gain of the analog output of the third-spindle speed
------	---

[Data type] Word

[Unit of data] 0.1%

[Valid data range] 700 to 1250

Set the data used for adjusting the gain of the analog output of the third spindle speed.

NOTE

This parameter is used only with multi-spindle control.

3821	Offset voltage compensation value of the analog output of the third spindle speed
------	---

[Data type] Word

[Unit of data] Velo

[Valid data range] -1024 to 1024

Set the offset voltage compensation value of the analog output of the third spindle speed.

- 1) Set 0 (standard setting) to this parameter.
- 2) Command a spindle speed that makes the spindle speed analog output 0.
- 3) Measure output voltage.
- 4) Set the following value to parameter No. 3821.

$$\text{Setting value} = \frac{-8191}{12.5} \times \text{offset voltage (V)}$$

- 5) After the parameter has been set, command a spindle speed whose analog output becomes 0 and confirm the voltage becomes 0V.

3822	Maximum speed of the third spindle
------	------------------------------------

[Data type] Word

[Unit of data] min⁻¹

[Valid data range] 0 to 32767

This parameter sets the maximum speed for the third spindle.

When a command specifying a speed exceeding the maximum spindle speed is specified, or the spindle speed exceeds the maximum speed because of the spindle speed override function, the spindle speed is clamped at the maximum speed set in the parameter.

WARNING

- 1 When 0 is set in this parameter, the setting of parameter No. 3772 for the first spindle is used. When 0 is set in parameter No. 3772, the spindle speed is not clamped.
- 2 When spindle speed command control is applied using the PMC, this parameter has no effect, and the speed of the spindle is not clamped.

NOTE

- 1 This parameter is valid when the multi-spindle control option is selected.
- 2 When the constant surface speed control option is selected, the spindle speed is clamped at the specified maximum speed, regardless of whether the G96 mode or G97 mode is set.

3831	Maximum spindle speed for gear 1 of the third spindle
------	---

3832	Maximum spindle speed for gear 2 of the third spindle
------	---

[Data type] Word

[Unit of data] min⁻¹

[Valid data range] 0 to 32767

Set the maximum spindle speed for each gear of the third spindle.

NOTE

These parameters are used only with muliti-spindle control.

3850	Maximum speed of the fourth spindle
------	-------------------------------------

[Data type] Word

[Unit of data] min^{-1}

[Valid data range] 0 to 32767

This parameter sets the maximum speed for the fourth spindle.

NOTE

- 1 These parameters are used for the multi-spindle control.
- 2 When this parameter is set to 0, parameter No. 3772 (maximum speed of the first spindle) is valid.

3851	Maximum spindle speed for gear 1 of the fourth spindle
------	--

3852	Maximum spindle speed for gear 2 of the fourth spindle
------	--

[Data type] Word

[Unit of data] min^{-1}

[Valid data range] 0 to 32767

Set the maximum spindle speed for each gear of the fourth spindle.

NOTE

These parameters are used for the multi-spindle control.

Warning

WARNING

Do not switch between the first to fourth position coders while a function that uses position coder feedback information is being executed. That is, PMC signal PC2SLC <G028#7> cannot be used while, for instance, a command for feed per rotation or thread cutting is taking place.

Caution**CAUTION**

- 1 If the primary spindle stop signal *SSTP for stopping all selected (SWS1 to SWS4) spindles' rotation is cleared, the speed command is restored. A spindle not selected by SWS1 to SWS4 and rotating at its previous speed, which is stopped using its respective command *SSTP1 to *SSTP4, cannot be restored to that speed when the signal is cleared.
- 2 Type A multi-spindle control differs from Type B in the relationship between the SWS1 and SIND signals for the first spindle. In Type B, SIND functions only when SWS1 is set to "1". In Type A, SIND functions whether SWS1 is "1" or "0"; each spindle is selected by either of its respective SWS1 or SIND signals being set to "1".

Note**NOTE**

- 1 The spindle orientation signal, spindle speed override signals, and spindle stop signal *SSTP function only for the selected spindles (corresponding to which spindle selection signals (SWS1 to SWS4) are set to 1).
- 2 The S 12-bit code signals R01O to R12O outputs the state of a selected spindle. If two or more spindles are selected at the same time, the states of the first, second, third, and fourth spindles are output in this order.
- 3 The multi-spindle function allows four position coder interfaces to be used. But the number of actual speed indications on the CNC screen does not change. The speed based on the feedback information of the selected position coder is displayed.
- 4 An SOR command has priority over S commands and SIND-based rotation control from the PMC, and will cause all selected spindles to perform orientation rotation.

9.11 RIGID TAPPING

9.11.1 General

In a tapping cycle (M series: G84/G74, T series: G84/G88), synchronous control is applied to the tapping operation of a tapping axis and the operation of the spindle.

This capability eliminates the need to use a tool such as a float tapper, thus enabling higher-speed, higher-precision tapping.

Whether a tapping cycle is an ordinary tapping cycle or rigid tapping cycle is determined by the miscellaneous function code for rigid tapping M29. (A different M code can be used by setting the parameters accordingly, but M29 is used in the description given here.)

By setting the parameters, G codes for tapping cycles can be changed to G codes for rigid tapping only. In this case, the CNC specifies M29 internally.

To perform rigid tapping, the following must be added to the ordinary connections:

- Connection of a position coder to the spindles (described in 9.11.2)
- Addition of a sequence to the PMC (described in 9.11.6 and 9.11.7)
- Setting of related parameters (described in 9.11.8)

This section provides an example of M series connection.

To avoid duplicate descriptions, assume the following unless noted otherwise:

- G code for a tapping cycle
M series: G84 (G74) T series: G84 (G88)
- Gear selection method
M series: M-type or T-type gear selection method
T series: T-type gear selection method only
- Parameters used according to the number of gear stages (No. 5221 to No. 5224, No. 5231 to No. 5234, No. 5241 to No. 5244, No. 5261 to No. 5264, No. 5271 to No. 5274, No. 5281 to No. 5284, No. 5291 to 5294, No. 5321 to No. 5324, etc.)
- M series: Up to three stages T series: Up to four stages
(Shared by the second spindle. Up to two stages for the second spindle.)

CAUTION

- 1 The description given in this section covers up to the fourth axis.
- 2 When M-type gear selection is used for the M series, the maximum spindle speed for rigid tapping (specified with parameters No. 5241 to 5243) must also be set for parameter No. 5243 regardless of the number of gear steps. (For a system having a single gear step, set the same value as that of parameter No. 5241 for parameter No. 5243. For a system having two gear steps, set the same value as that of parameter No. 5242 for parameter No. 5243.)

The descriptions given in this section (such as spindle gear switching and M-type/T-type) are based on the explanation given in Section 9.3. Refer to Section 9.3 as necessary.

Specification of M series/T series

• Rigid tapping of M series

The differences in the specifications for rigid tapping for the M series and T series are described below.

The tapping cycle G84 and the reverse tapping cycle G74 can be used to specify M series rigid tapping.

A tapping axis can be arbitrarily selected from the basic axes X, Y, Z, as well as axes parallel to the basic axes, by setting the corresponding parameters accordingly (bit 0 (FXY) of parameter No. 5101).

The spindle operations of G84 and G74 are reversed with respect to each other.

If multi-spindle control is added as well as rigid tapping by the first spindle (analog or serial), rigid tapping by selecting the second or third spindle (serial) is also enabled.

• Rigid tapping of T series

The face tapping cycle G84 and the side tapping cycle G88 can be used to specify T series rigid tapping.

Depending on the rigid tapping command, rigid tapping can be performed along the Z-axis (when G84 is used) or the X-axis (when G88 is used).

A reverse tapping cycle, like that supported by M series, is not available.

If multi-spindle control is added as well as rigid tapping by the first spindle (analog or serial), rigid tapping by selecting the second or third spindle (serial) is also enabled.

For a two-path lathe, rigid tapping can be performed using a combination of the spindle and tapping axis selected in each path.

Rigid tapping using a mixture of paths is not allowed. For example, rigid tapping in combination of a tapping axis of tool post 1 and the spindle of tool post 2, by issuing a tapping command to tool post 1, is not supported.

9.11.2 Connection Among Spindle, Spindle Motor, and Position Coder

As shown in the figure below a gear ratio can be inserted between the spindle and spindle motor, and between the spindle and position coder.

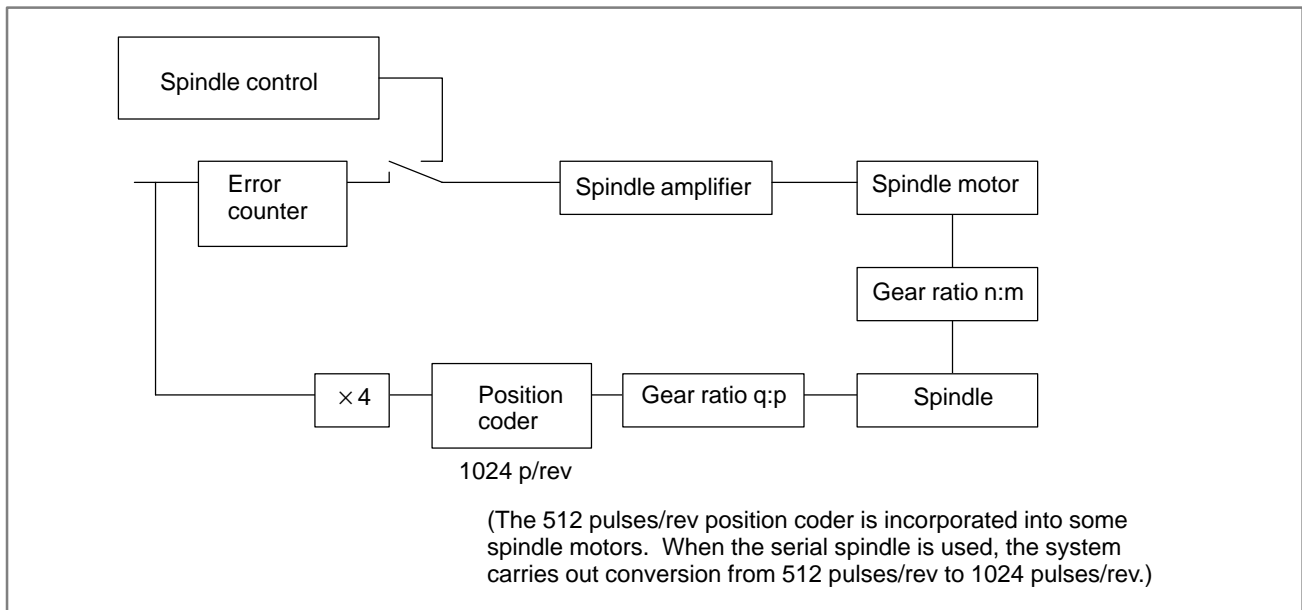

(1) Gear between spindle and spindle motor

Up to three gear stages (1st spindle of M series) or four gear stages (1st spindle of T series) can be provided between the spindle and the spindle motor. The gear ratio is arbitrary. Up to two gear stages (2nd spindle/3rd spindle) can be provided between the spindle and the spindle motor. The distance of spindle rotation per revolution of spindle motor is different, based on the gear ratio. The speed command to the spindle motor will be adjusted. See (2), below, for additional information regarding a spindle motor incorporating a position coder.

(2) Gear between spindle and position coder

The position coder is used to detect the position of the spindle. The gear ratio for the spindle and position coder is specified in the parameter sets No. 5221 to No. 5223 and No. 5231 to No. 5233, or parameter set PG1 and PG2 No. 3706 #0, #1, parameter P21, P22 (No. 3707 #0, #1)/P31, P32 (No. 3707 #2, #3) for 2nd spindle/3rd spindle. Which parameter is set for use is specified by parameter VGR No. 5200 #1.

- **Arbitrary gear ratio (VGR=1)**

This is used if the gear ratio for the spindle motor and position coder (built-in or separate) is not 1:1, 1:2, 1:4, or 1:8, set VGR to 1 and set the gear ratio using parameter No. 5221 to 5224.

When position coder is mounted on a spindle, the gear ratio for the spindle motor and position coder cannot be changed by shifting the spindle motor and spindle gears. Parameters No. 5221 to 5224 must all specify the same value for the teeth of the individual spindle gears. Parameters No. 5231 to 5234 must all specify the same value for the teeth of individual position coder gears.

The 1024 or 512 pulses/rev position coder is built into the spindle motor. For the 512 pulses/rev version, specify double the number of teeth on each gear for the position coder. (Double the number of teeth need not be specified for the serial spindle.)

1st spindle of M series allows up to three stages, regardless of which gear selection method has been selected. (Parameter Nos. 5224 and 5234 cannot be used.)

1st spindle of T series supports up to four stages. (Set parameter Nos. 5221 to 5224 and 5231 to 5234.) When the multi-spindle function is used to perform rigid tapping with the second spindle/third spindle, up to two stages are supported. (Set parameter Nos. 5221, 5222, 5231, and 5232.)

Example)

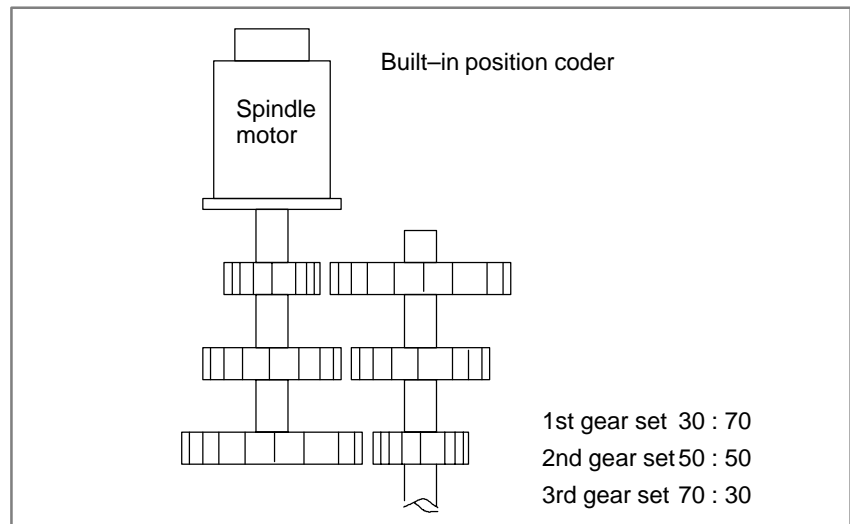

Parameter No.	Set value		Meaning
	512p/rev Position coder	1024p/rev Position coder	
5221	70		Number of teeth of the 1st gear for the spindle side
5222	50		Number of teeth of the 2nd gear for the spindle side
5223	30		Number of teeth of the 3rd gear for the spindle side
5231	60 Note)	30	Number of teeth of the 1st gear for the position coder side
5232	100 Note)	50	Number of teeth of the 2nd gear for the position coder side
5233	140 Note)	70	Number of teeth of the 3rd gear for the position coder side

NOTE
Double value setting is not required for serial spindle.

- **Gear ratio is 1:1, 1:2, 1:4, 1:8 (VGR=0)**

If the gear ratio is either 1:1, 1:2, 1:4, and 1:8, it is set using parameters PG1 and PG2 (No. 3706 #0, #1). This applies if the position coder is mounted in a spindle or built into a spindle motor when only one stage gear is provided. .

For 2nd spindle/3rd spindle, set it to parameter P21, P22 (No.3707#0, #1)/P31, P32 (No. 3707 #2, #3).

Parameter		Gear ratio		Detection unit
PG2	PG1	Spindle	Position coder	
0	0	1	1	360/4096=0.08789 deg
0	1	1	2	360/4096 × 2=0.17578 deg
1	0	1	4	360/4096 × 4=0.35156 deg
1	1	1	8	360/4096 × 8=0.70313 deg

The spindle motor building in the 512 pulses/rev position coder uses the values set forth in the following table. A serial spindle does not require double-value setting; use the same values as for the spindle motor building in the 1024 pulses/rev position coder.

Built-in position coder 512p/rev	Gear ratio		Parameter		Gear ratio of spindle to position coder	Detection unit (deg)
	Spindle motor	Spindle	PG2	PG1		
	1	1	0	1	1:2	0.17578
	2	1	1	0	1:4	0.35156
	4	1	1	0	1:8	0.70313

(3) Rigid tapping and machines with multiple gears

If the M type gear selection method is selected, the CNC determines whether gears need changing using the gear change specification mentioned in section 9.3. If the gears need to be changed, the CNC generates the S function code read signal SF (F007#2) and gear selection signals GR10, GR20, and GR30 (F034#0-#2) to notify the PMC. Change gears using the PMC, based on these signals.

If the T type gear selection method is selected, the CNC does not process gear changes. When the CNC has the S function code, it outputs signal SF and S function code signals S00 to S31 (F022#0-F025#7) to the PMC. (However, parameter No. 3705 and its related parameters need to be set for S code and SF signal output). Using the PMC, determine whether gears need changing, and make the change if needed. Input gear selection signals GR1 and GR2 <G028#1,#2> or GR21 <G029#0> for 2nd spindle/3rd spindle for the selected gear, and notify the CNC of them.

To perform rigid tapping with the serial spindle, enter the clutch/gear selection signals CTH1 and CTH2 (G070#3,#2 for the first spindle, G074#3, #2 for the second spindle, and G204#3, #2 for the third spindle) from the PMC. Notify the serial spindle control unit of these signals via the CNC, irrespective of the gear selection method.

Changing gears during rigid tapping requires a different process from that for gear changes during normal machining. As described above, changing gears conforms to the gear change specifications mentioned in section 9.3 when the M type gear selection method has been selected. With the T type gear selection method, changing gears conforms to the logic programmed in the PMC.

Regardless of the option's selection, if the range in which the spindle speed specified by the S function code does not correspond to the currently selected gear, the gears are changed.

The following tables list the spindle speed ranges for each gear during normal machining (assuming no machine restrictions) and rigid tapping:

Gear	Spindle speed range (normal machining)	
	Lower limit	Upper limit
Low-speed gear	1 revolution	Maximum low-speed gear speed = $\frac{\text{Maximum spindle motor speed} \times L\%}{\text{Low-speed gear ratio}}$
Medium speed gear	Maximum low-speed gear speed + 1 revolution	Maximum medium-speed gear speed = $\frac{\text{Maximum spindle motor speed} \times L\%}{\text{Medium speed gear ratio}}$
High-speed gear	Maximum medium-speed gear speed + 1 revolution	Maximum high-speed gear speed = $\frac{\text{Maximum spindle motor speed} \times L\%}{\text{High-speed gear ratio}}$

NOTE

This table shows an example of three gears. L% indicates a spindle motor protection constant (up to 100). L can be specified for each gear using method B for changing in M type gear selection method (bit 2 (SGB) of parameter No. 3705 =1).

Gear	Spindle speed range (during rigid tapping)	
	Lower limit	Upper limit
Low-speed gear	1 revolution	Maximum low-speed gear speed Basic spindle motor speed + α = Low-speed gear ratio
Medium speed gear	Maximum low-speed gear speed + 1 revolution	Maximum medium-speed gear speed Basic spindle motor speed + α = Medium-speed gear ratio
High-speed gear	Maximum medium-speed gear speed + 1 revolution	Maximum high-speed gear speed Basic spindle motor speed + α = High-speed gear ratio

NOTE

This table show an example of three gears. For the basic spindle motor speed, refer to the spindle motor description manual. “+ α ” means that the spindle motor speed may slightly exceed the basic spindle motor speed.

If the M type gear selection method is used, use gear change method B (bit 3 (SGT) of parameter No. 3705 = 1) in the tapping cycle to specify the following:

The table above shows the maximum low-speed gear speed during rigid tapping for low-/medium-speed gear change position D (parameter No. 3761).

The table above shows the maximum medium-speed gear speed during rigid tapping for medium-/high-speed gear change position E (parameter No. 3762).

If the T type gear selection method is used, add the rigid tapping logic to the logic programmed in the PMC.

See Section 9.3, “Spindle Control” for details of the spindle gear change specifications.

The loop gain can be specified for each gear. Specify “0” for parameter No. 5280 and specify loop gains for each gear for parameter Nos. 5281 to 5284. Unless “0” is specified for parameter No. 5280, the loop gains for each gear are disabled, and the loop gain common to all gears, the value of parameter No. 5280, is enabled.

Specify the time constant and the maximum spindle speed for each gear. Use parameters Nos. 5261 to 5264 to specify the time constant.

Use parameters Nos. 5241 to 5244 to specify the maximum spindle speed.

For M type gear selection method, set the maximum spindle speed to parameter No. 5243, irrespective of the number of gear stages used.

Setting bit 2 (TDR) of parameter No. 5201 to “1” enables setting of the time constants used during extraction for each gear set. Specify the extraction time constant for each gear in parameter Nos. 5271 to 5274.

If bit 1 (VGR) of parameter No. 5200 is set to “1”, the gear ratio for the spindle and position coder can be set to anywhere between 1:32767 and 32767:1 in one-increment units for three gear sets with 1st spindle of M series, four gear sets with 1st spindle of T series, or two gear sets with 2nd spindle/3rd spindle. However 1:8 to 8:1 is the recommended value.

9.11.3 Rigid Tapping Specification

- **Feed rate**
In rigid tapping mode, the tapping axis is fed at a rate specified by F. The spindle speed is specified by $S \times 360(\text{deg}/\text{min})$. Use of override is invalid for both of them. An override of 200% can be applied to withdrawal operations by setting bit 4 (DOV) of parameter No. 5200 to “1”, and setting an appropriate override value in parameter RGOVR of No. 5211. Using the OVU parameter (bit 3 of parameter No. 5201) enables an override value of up to 2000% to be applied. The time constant for withdrawal operations can be modified by bit 2 (TDR) of parameter No. 5201; when it is set to “1”, the values in parameter Nos. 5271 to 5274 are used as the time constant for withdrawal.
- **Acceleration and deceleration**
Linear acceleration/deceleration is valid for rigid tapping.
- **Override**
Override is invalid during rigid tapping. Fixed override can be applied to withdrawal operations by setting bit 4 (DOV) of parameters No. 5200 or RGOVR of No. 5211.
- **Dry run**
Dry run is valid for G84 (G74). When the dry run is applied to the tapping axis speed of G84 (G74), tapping is performed. The spindle speed will match the dry run speed.
- **Machine lock**
Machine lock is valid for G84 (G74).
When G84 (G74) is executed with the machine locked, however the tapping axis and the spindle do not move.
- **Reset**
When the reset operation is performed during rigid tapping, the mode is reset. The spindle motor goes to the ordinary mode, but G84 (G74) mode is not reset.
- **Feed hold and single block**
The feed hold and single block functions are nullified for G84 (G74).
The feed hold and single block functions in rigid tapping mode can be effective by setting bit 6 (FHD) of parameter No. 5200 to “1”.
As with the machine lock signal, the feed hold and single block functions are also effective for the spindle indirectly, through tapping axis operations.
- **Operation mode**
G84 (G74) can be executed only in the MEM and MDI modes.
- **Manual feed**
Rigid tapping cannot be performed in the manual feed mode.
- **Backlash compensation**
In rigid tapping mode, the backlash is compensated for the lost motion at forward and reverse spindle rotations. Set it using parameter No. 5321 to No 5324. The normal backlash compensation is inserted on the tapping axis.

9.11.4 Display Data on the Diagnosis Screen

- **Common display data**

For rigid tapping adjustment, the diagnosis screen displays information related to rigid tapping.

For part of the display data, the user can choose between two sets of data items relating to the synchronization of the spindle and tapping axis by setting bit 0 (DGN) of parameter No. 5204.

The following information items are always displayed, regardless of the setting of bit 0 (DGN) of parameter No. 5204:

- Spindle position deviation → Diagnosis No. 450
- Number of command pulses distributed to the spindle (momentary value) → Diagnosis No. 451
- Cumulative number of command pulses distributed to the spindle → Diagnosis No. 454

- **Display of rigid tapping synchronization error (When DGN = 0)**

When bit 0 (DGN) of parameter No. 5204 is set to 0, the following items of information are displayed.

(Diagnosis Nos. 452 and 453 are not displayed.)

- Spindle-converted move command difference → Diagnosis No. 455
- Spindle-converted position deviation difference → Diagnosis No. 456
- Synchronization error range → Diagnosis No. 457

Spindle-converted move command difference

$$= \Sigma \frac{\text{spindle move command}}{\text{gear ratio}} - \Sigma \frac{(\text{tapping axis move command}) \times 4096}{\text{thread lead}}$$

Spindle-converted position deviation difference

$$= \frac{\text{spindle position deviation}}{\text{gear ratio}} - \frac{(\text{tapping axis position deviation}) \times 4096}{\text{thread lead}}$$

Synchronization error range

= (maximum spindle-converted move position deviation difference on the positive side)

– (maximum spindle-converted position deviation difference on the negative side)

If a maximum allowable synchronization error range is set in parameter No. 5214, the position deviation alarm during spindle movement (alarm No. 741) is issued to indicate that the set synchronization error range has been exceeded. (If 0 is set in parameter No. 5214, no check is performed to detect whether the synchronization error range has been exceeded.)

- **Rigid tapping error display (error difference display) (When DGN = 1)**

When bit 0 (DGN) of parameter No. 5204 is set to 1, the following items of information are displayed. (Diagnosis Nos. 455, 456, and 457 are not displayed.)

- Momentary error difference between the spindle and tapping axis → Diagnosis No. 452
- Maximum error difference between the spindle and tapping axis → Diagnosis No. 453

Diagnosis No. 0452 is cleared to “0” when rigid tapping mode is set or canceled, and diagnosis No. 0453 is cleared to “0” in the positioning of the rigid tapping cycle.

The following figure shows the tapping axis as the Z axis.

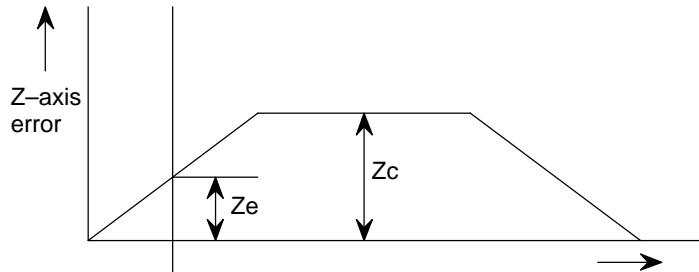

$$Z_c = \frac{\text{Speed}}{60} \times \frac{1}{\text{Gain}} \times \frac{1}{\text{Detection unit}} \times 10^2 \text{ (Theoretical value)}$$

Z_e = Z-axis error counts (measured value)

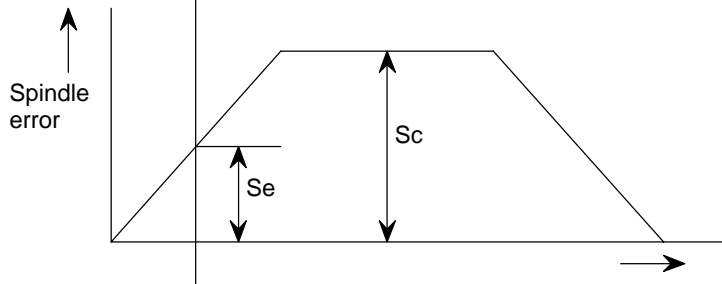

$$S_c = \frac{\text{Speed} \times 360}{60} \times \frac{1}{\text{Gain}} \times \frac{1}{\text{Detection unit}} \times 10^2 \text{ (Theoretical value)}$$

S_e = Spindle error counts (measured value)

- Speed : mm/min or inch/min
- Gain : 0.01 s^{-1}
- Detection unit : mm, inch, or deg
- Speed : min^{-1}

$$\Delta Z = \frac{Z_e}{Z_c} \times 100 \text{ [%]}$$

$$\Delta S = \frac{S_e}{S_c} \times 100 \text{ [%]}$$

The error difference between the spindle and Z axis can be obtained by $\Delta S - \Delta Z$. This value is sampled at intervals of 64 ms.

Diagnosis screen

- **Spindle position deviation**

0450	SPINDLE MOTION ERROR
------	----------------------

Spindle position deviation during rigid tapping

[Unit] Pulse

- **Number of pulses distributed to the spindle**

0451	SPINDLE MOTION PULSE
------	----------------------

Number of pulses distributed to the spindle during rigid tapping

[Unit] Pulse

- **Error difference between the spindle and tapping axis (momentary value)**

0452	RIGID ERROR
------	-------------

Momentary error difference between the spindle and tapping axis during rigid tapping (signed)

[Unit] %

NOTE

This data item is displayed only when bit 0 (DGN) of parameter No. 5204 is set to 1.

- **Error difference between the spindle and tapping axis (maximum)**

0453	RIGID ERROR(MAX)
------	------------------

Maximum error difference between the spindle and tapping axis during rigid tapping (absolute value)

[Unit] %

NOTE

This data item is displayed only when bit 0 (DGN) of parameter No. 5204 is set to 1.

- **Cumulative number of pulses distributed to the spindle during rigid tapping**

0454	SPINDLE PULSE(SUM)
------	--------------------

Cumulative number of pulses distributed to the spindle during rigid tapping

[Unit] Pulse

- **Spindle-converted move command difference during rigid tapping (momentary value)**

0455	SYNC. PULSE(SUM)
------	------------------

Momentary spindle-converted move during command difference between the spindle and the tapping axis during rigid tapping

[Unit] Pulse

NOTE

This data item is displayed only when bit 0 (DGN) of parameter No. 5204 is set to 0.

- **Spindle-converted position deviation difference during rigid tapping (momentary value)**

0456	SYNC. ERROR
------	-------------

Momentary spindle-converted position deviation difference between the spindle and the tapping axis during rigid tapping

[Unit] Pulse

NOTE

This data item is displayed only when bit 0 (DGN) of parameter No. 5204 is set to 0.

- **Synchronization error range during rigid tapping (momentary value)**

0457	SYNC. WIDTH
------	-------------

Synchronization error range during rigid tapping (maximum value)

[Unit] Pulse

NOTE

This data item is displayed only when bit 0 (DGN) of parameter No. 5204 is set to 0.

9.11.5 Command Format

Command format for the T series

The rigid tapping command format for the T series is described below. For an explanation of the command format used with the M series, refer to Section II.13.2.2 of the “Operator’s Manual for Machining Center (B-63534EN) ”.

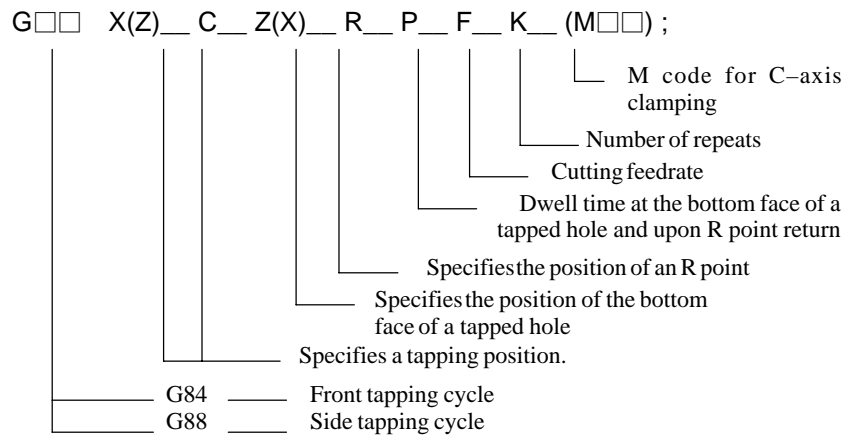

The rigid tapping mode can be specified by using any of three methods:

- Specification of M29S**** before specifying a tapping cycle
- Specification of M29S****in the same block
- Enabling rigid tapping to be performed without specifying M29S****

When using the third method, specify S**** either before or in a block containing G84 (G88).

Thus, the spindle stops, after which the tapping cycle specified next is placed in rigid tapping mode.

Rigid tapping mode will be canceled by G80;. Note, however, that a G code for another canned cycle, or a group 01 G code will also cancel rigid tapping mode.

When rigid tapping is terminated by a command issued to cancel rigid tapping mode, the spindle stops. (Output to the spindle is equivalent to the specification of S0.)

A reset (by means of the RESET button or an external reset) can also cancel rigid tapping mode. Note, however, that canned cycle mode is not canceled by a reset.

- Specifying M29 before a block containing G84 (G88)

M29 S****;

G□□X (Z) ___C___Z (X) ___R___P___F___K___ (M□□) ;

X (Z) ___C___;

X (Z) ___C___;

.

.

G80;

Rigid tapping mode

- Specifying M29 and G84 (G88) in the same block (Note, however, that M29 and M□□ for C-axis clamping cannot be specified in the same block.)

```
G□□X (Z) __Z (X) __R_P_F_K_M29****;
X (Z) __C__;
X (Z) __C__;
.
.
G80;
```

Rigid tapping mode

- Converting G84 (G88) to a G code for rigid tapping (by setting bit 0 (G84) of parameter No. 5200 to 1)

```
G□□X (Z) __C_Z (X) __R_P_F_K_S**** (M□□);
X (Z) __C__;
X (Z) __C__;
.
.
G80;
```

Rigid tapping mode

Notes on the T series

NOTE

- 1 In feed per minute mode, F_/S**** determines a thread lead. In feed per rotation mode, F_ specifies a thread lead.
- 2 S**** must specify a value that does not exceed the value set in the maximum spindle speed parameter (No. 5241 to 5244) for the gear to be used. Otherwise, P/S alarm No. 200 is issued in a block containing G84 (G88).
- 3 F_ must specify a value that does not exceed the maximum cutting feedrate. When 0 is specified, P/S alarm No. 201 is issued.
- 4 Between M29 and G84 (G88), S and a command for movement along an axis must not be specified. Further, M29 must not be specified in a tapping cycle. Otherwise, P/S alarm Nos. 203 and 204 are issued, respectively.

G84 G85 (Tapping cycle)

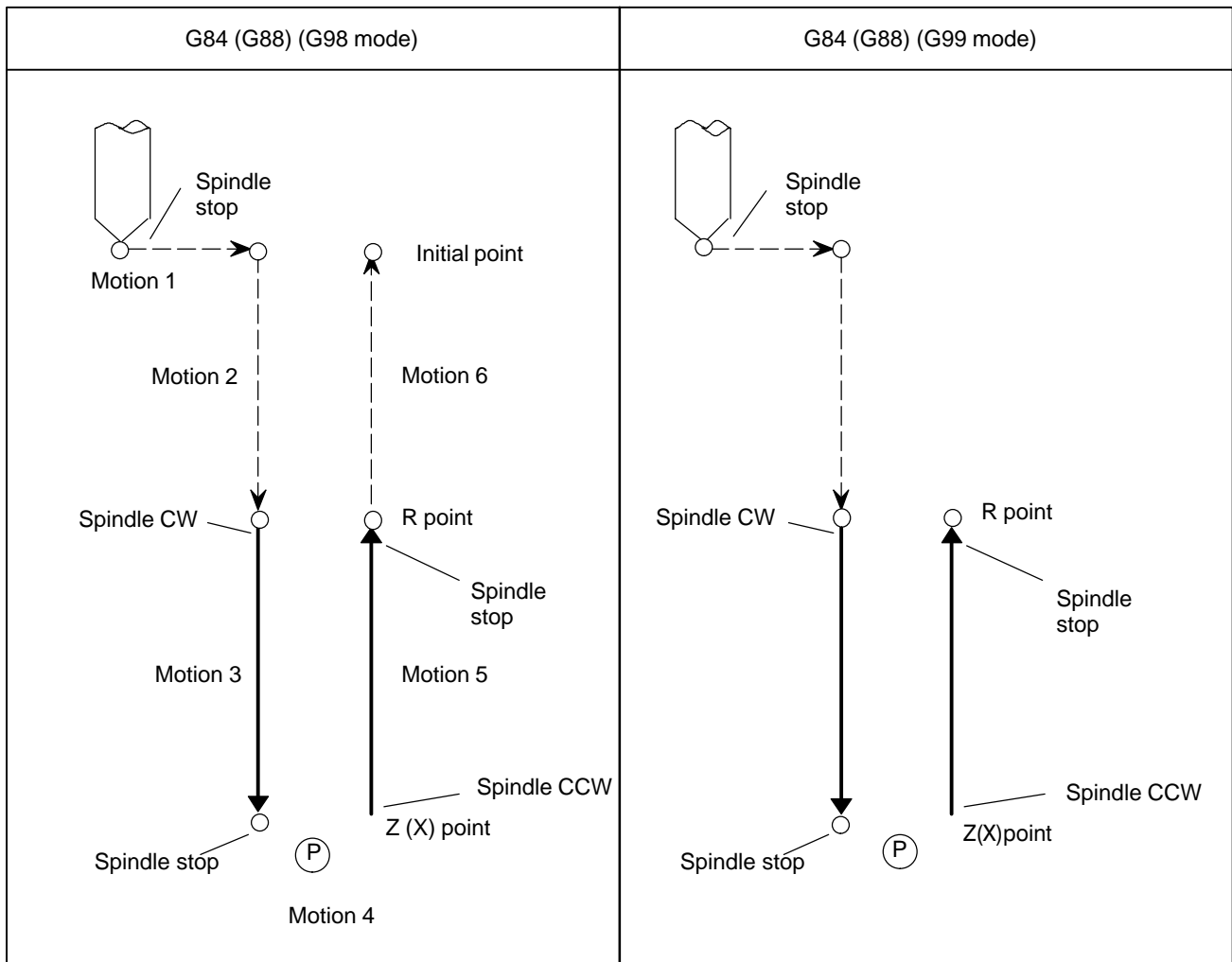

--- Rapid traverse
 ——— Z (X) axis feed

Ⓟ Dwell

CAUTION

During cutting feed along the Z-axis (X-axis), the feedrate override is forced to 100%. The spindle speed override is also forced to 100%. For a retract motion (motion 5), a fixed override of up to 2000% can be applied by specifying bit 4 (DOV) of parameter No. 5200, bit 3 (OVU) of parameter No. 5201, and parameter No. 5211 (RGOVR).

NOTE

G code system A does not include G98 (return to initial level) and G99 (return to R point level). Return to the initial level is always used.

Rigid tapping in feed per rotation mode

Rigid tapping is classified into two types: rigid tapping in feed per rotation mode (G99) and rigid tapping in feed per minute mode (G98).

Example)

The example below specifies rigid tapping in feed per rotation mode for cutting a thread with a lead of 1 mm at a spindle speed of 1,000 min⁻¹.

```
O0001 ;
G99 ;
.
.
.
M29 S1000 ;
G84 Z-100. R-20. F1. ;
.
.
.
G80 ;
```

The example below specifies rigid tapping in feed per minute mode for cutting the same thread at the same spindle speed as above. (In feed per minute mode, F/S determines the thread lead.)

```
O0002 ;
G98 ;
.
.
.
M29 S1000 ;
G84 Z-100. R-20. F1000 ;
.
.
.
G80 ;
```

Units of F

	Metric input	Inch input	Remarks
G98	1 mm/min	0.01 inch/min	A fractional value can be specified.
G99	0.0001 mm/ rev	0.000001 inch/rev	A fractional value can be specified.

NOTE

- 1 G98 and G99 are modal G codes. Upon power-up, G99 (feed per rotation mode) is set.
- 2 Even in feed per rotation mode, a pulse distribution command is converted to a feed per minute command. Thus, feed per rotation mode does not strictly implement feed per rotation. Accordingly, even if the spindle stops for some reason, the tapping axis (Z-axis or X-axis) does not stop.

9.11.6 Signal

9.11.6.1 Signals for the rigid tapping function

Rigid tapping signal RGTAP<G061#0>

[Classification] Input signal

[Function] When M29 (miscellaneous function for preparation for rigid tapping) is specified, the PMC enters rigid tapping mode, then turns on this signal to notify the CNC.

1 : The PMC enters in rigid tapping mode.

0 : The PMC does not enter rigid tapping mode.

For an explanation of placing the PMC in rigid tapping mode, see the description of the interface with the PMC, given later.

This signal posts whether the PMC has entered rigid tapping mode. If this signal is not set to 1, even when M29 is specified, a P/S alarm is issued in a G84 (G74) block.

Spindle rotation direction signals RGSPM, RGSP <F065#1, #0> (M series)

[Classification] Output signal

[Function] During rigid tapping, these signals notify the PMC of whether the spindle is rotating in the forward or reverse direction.

During rigid tapping, the spindle is:

RGSP 1 : Rotating in the forward direction (CW).

0 : Not rotating in the forward direction.

RGSPM 1 : Rotating in the reverse direction (CCW).

0 : Not rotating in the reverse direction.

[Output condition] These signals are output when the spindle is rotating in rigid tapping mode. This means that, even in rigid tapping mode, these signals are not output, for example, when the spindle is being positioned to a hole position, or a dwell operation is in progress at the bottom of a hole or at an R point.

These signals are not output in the feed hold state or single block stop state. When the spindle is placed in the interlock stop state, machine lock state, or Z-axis ignore state, however, the spindle is not regarded as having stopped; these signals are output.

These signals are valid only in rigid tapping mode. In normal spindle control, these signals are not output; both RGSP and RGSPM are set to "0".

Rigid tapping in-progress signal RTAP<F076#3>

[Classification] Output signal

[Function] This signal notifies the PMC that rigid tapping mode is active.

RTAP 1 : Rigid tapping mode is currently active.

0 : Rigid tapping mode is not currently active.

By latching M29, the PMC knows that rigid tapping mode has been specified, and thus performs the required processing on the PMC side. This signal can substitute for the latching of M29. Even in this case, however, FIN for M29 cannot be omitted.

9.11.6.2 Signals related to S code output

Spindle enable signal ENB<F001#4>

Second spindle enable signal ENB2<F038#2> Third spindle enable signal ENB3<F038#3>

[Classification] Output signal

[Function] These signals post whether the spindle output is 0. In rigid tapping mode, these signals are used to cancel rigid tapping in a PMC sequence associated with rigid tapping.

For details, see the explanation of the interface with the PMC, given later.

Spindle-speed function code signals (binary output) S00 to S31 <F022 to F025>

Spindle-speed function strobe signal SF<F007#2>

[Classification] Output signal

[Function] These signals send S codes specified for the CNC, in binary format, to the PMC.

[Output condition] When an S code is specified, the specified value is output, in binary format, with these signals. When the new spindle speed data is fully set, the SF signal is set to "1".

Before rigid tapping can be performed, however, parameter setting is required to output these signals, as described below.

M series: SF output depends on the gear selection method, as described below.

[1] M-type gear selection method

SF output depends on bit 6 (SFA) of parameter No. 3705.

[2] T-type gear selection method

SF output depends on the setting of bit 5 (NSF) of parameter No. 3705.

T series: The following parameter needs to be set to output S codes and SF: Bit 4 (EVS) of parameter No. 3705 = 1

In rigid tapping, when SF is to be used by the PMC to read an S code output signal for gear switching or output switching, set the above parameters as required.

NOTE

1 The timing charts, given later, give examples of gear switching by setting the parameters as follows:

M series: SFA = 0, NSF = 0

T series: EVS = 1

2 When the constant surface speed control function is being used, an S code (specifying a surface speed) used for constant surface control (G96) is output. Such an S code can be distinguished from an S code used for specifying a rotation speed. One method is to use, for example, the constant surface speed control in-progress signal <F002#2> for the processing performed on the PMC side. Another method is to mask the S code and SF signal, output by setting bit 0 (ESF) of parameter No. 3705.

9.11.6.3

Signals related to gear switching

Gear selection signals

(output)

GR30, GR20, GR10

<F034#2, #1, #0>

(M series)

[Classification] Output signal

[Operation] When M-type gear selection is being used, these signals are used in a PMC sequence for rigid tapping.

The signals post, to the PMC, information about a spindle gear to be used, according to the value of S**** specified at the execution of G84 (G74).

When gear switching becomes necessary, the states of the signals change together with the SF signal.

The PMC should perform gear switching according to the information posted by the gear selection signals.

Reference information: The table below indicates the relationship between the output signals and gear selection.

	GR30	GR20	GR10
1st (low) speed gear	×	×	○
2nd (medium) speed gear	×	○	×
3rd (high) speed gear	○	×	×

Gear selection signals (input)

GR2, GR1<G028#2, #1>

[Classification] Input signal

[Operation] When T-type gear selection is being used, these signals are used in a PMC sequence for rigid tapping.

The signals post, to the CNC, information about a spindle gear to be used.

Reference information: The table below shows the relationship between the output signals and spindle gear selection.

	GR2	GR1
1st (low) speed gear	×	×
2nd (medium) speed gear	×	○
3rd (high) speed gear	○	×
4th (high) speed gear	○	○

← In Mseries rigid tapping, the specification of the 4th (high) speed gear is invalid. If specified, the system assumes that the 3rd (high) speed gear has been specified.

Gear selection signal (input)

GR21<G029#0>

GR31<G029#2>

[Classification] Input signal

[Operation] When rigid tapping with the second spindle or third spindle is being performed, the signal is used in the PMC sequence program.

The signal notifies the CNC of spindle gear information of the selected spindle.

The input signal is related to gear selection as described below.

GR21/GR31 1 : The second stage is currently selected as the second spindle gear.
0 : The first stage is currently selected as the second spindle gear.

	GR21/GR31
1st speed gear	×
2nd speed gear	○

When a serial spindle is used, the serial spindle clutch/gear selection signals (G070#3, #2 for the first spindle, G074#3, #2 for the second spindle, and G264#3, #2 for the third spindle) must be set in addition to the setting of the gear selection signal described above.

9.11.6.4

Signals related to second spindle/third spindle rigid tapping

Gear selection signal (input)
GR21<G029#0>
GR31<G029#2>

See the description of the signals related to gear switching, given above.

Signals related to multi-spindle control

Spindle selection signals SWS1, SWS2, SWS3
<G027#0, #1, #2>

Rigid tapping spindle selection signals RGTSP1, RGTSP2, RGTSP3<G061#6, #5, #4>
(T series)

[Classification] Input signal

[Operation] SWS1 to SWS3 are used to transfer spindle commands when the multi-spindle control option is used. In rigid tapping, the signals can be shared to select a spindle to be used for rigid tapping. (The signals can be used for this purpose when bit 7 (SRS) of parameter No. 5200 is set to 0.) RGTSP1 and RGTSP2 are used to select a spindle used for rigid tapping, independently of the SWS1 to SWS3 signals, when the multi-spindle control option is being used. (The RGTSP2 and RGTSP1 signals can be used when bit 7 (SRS) of parameter No. 5200 is set to 1. These signals are supported only by the T series.)

See the tables below for details of the settings of these signals.

(T/M series) When bit 7 (SRS) of parameter No. 5200 is set to 0, to select a spindle to be used for rigid tapping, set the signals as indicated below.

Spindle used for rigid tapping	Signal state		
	SWS1	SWS2	SWS3
First spindle	"1"	"1" or "0"	"1" or "0"
Second spindle	"0"	"1"	"1" or "0"
Third spindle	"0"	"0"	"1"
P/S alarm No. 205 is issued.	"0"	"0"	"0"

(T series) When bit 7 (SRS) of parameter No. 5200 is set to 1, to select a spindle to be used for rigid tapping, set the signals as indicated below.

Spindle used for rigid tapping	Signal state		
	RGTSP1	RGTSP2	RGTSP3
First spindle	"1"	"1" or "0"	"1" or "0"
Second spindle	"1"	"1"	"1" or "0"
Third spindle	"0"	"0"	"1"
P/S alarm No. 205 is issued.	"0"	"0"	"0"

WARNING

These signals must be applied before the command for rigid tapping (M29 S...; G84 X...) is specified. The states of these signals must not be changed before rigid tapping has been completed.

Spindle-by-spindle stop signals

*SSTP1, *SSTP2, *SSTP3
<G027#3, #4, #5>

[Classification] Input signal

[Operation] These signals are used to stop each spindle when the multi-spindle control option is used. In a PMC sequence for rigid tapping, the ENB and ENB2 signals are used. Accordingly, the logic of the signals used for a spindle selected to perform rigid tapping must match the logic of the spindle stop signal *SSTP.

*SSTP1 1 : The output to the first spindle is not forced to 0 min⁻¹.
0 : 0 min⁻¹ is commanded to first spindle.

*SSTP2 1 : The output to the second spindle is not forced to 0 min⁻¹.
0 : 0 min⁻¹ is commanded to second spindle.

Second/third position coder selection signal

PC2SLC<G028#7>
PC3SLC<G026#0>

[Classification] Input signal

[Operation] This signal is used to select the position coder when the multi-spindle control option is being used. Note, however, that it cannot be used with a spindle selected to perform rigid tapping.

For rigid tapping, this signal is not used. Instead, a position loop is constructed by combining the first spindle with the first position coder, by combining the second spindle with the second position coder, or by combining the third spindle with the third position coder.

However, the display of the actual speed is switched by this signal, even during rigid tapping (See Section 9.10 for details of this signals).

**9.11.6.5
Signal addresses**

	#7	#6	#5	#4	#3	#2	#1	#0
G026								PC3SLC
G027				*SSTP2	*SSTP1		SWS2	SWS1
G028	PC2SLC					GR2	GR1	
G029						GR31		GR21
G061		RGTSP3	RGTSP2	RGTSP1				RGTAP
	#7	#6	#5	#4	#3	#2	#1	#0
F001				ENB				
F007						SF		
F034						GR30	GR20	GR10
F038					ENB3	ENB2		
F065							RGSPM	RGSP
F076					RTAP			

**9.11.6.6
Notes on interface with the PMC**

Rigid tapping mode management and ENB (or ENB2)

The following describes some notes in designing the interface with the PMC.

The PMC must manage rigid tapping mode as follows: rigid tapping mode is set using M29, and is canceled upon the issue of a reset or at the falling edge of the spindle enable signal ENB in rigid tapping mode. ENB is used during rigid tapping in this way, so the spindle stop signal *SSTP must not be set to “0”.

However, *SSTP and SOR may be used for gear switching. To do so, ensure that the PMC does not cancel rigid tapping mode on a falling edge of ENB while *SSTP is “0”. Rigid tapping mode may be set on a rising edge of the RTAP signal instead of by using M29, and canceled on a falling edge of the RTAP signal instead of the ENB signal.

In rigid tapping using the second spindle/third spindle, the ENB2/ENB3 signal must be used for rigid tapping mode management.

Controlling spindle output by the PMC

When the SIND signal is set to “1”, spindle output is controlled by the signals (SSIN, SGN, R01I to R12I) output from the PMC.

At this time, the effect of ENB is as described above. In addition, when rigid tapping mode is canceled in a block containing G80, the momentary rotation of the spindle, caused by a delay in the PMC processing, can result. Accordingly, the PMC’s control over spindle output must be disabled in rigid tapping mode by setting SIND to “0”.

For the same reason, the PMC's control over second spindle/third spindle output must be disabled in rigid tapping mode by setting SIND2/SIND3 to "0".

T-type gear selection method

When T-type gear selection is used, the PMC must determine whether gear switching is to be performed, and subsequently perform gear switching as required. For this purpose, each time a spindle-speed function code is specified, the spindle-speed function code read signal (SF) and spindle-speed function code signals (S00 to S31) must be output to the PMC. The required parameter settings are described below.

- M series: Set bit 5 (NSF) of parameter No. 3705 to 0 to output SF.
- T series: Set bit 4 (EVS) of parameter No. 3705 to 1 to output SF.

Gear switching timing

In general, a block containing M29 (miscellaneous function for preparation for rigid tapping) specifies S****, S**** being output when a block containing G84 (G74) is executed. This means that gear switching is performed in the block specifying G84 (G74).

When rigid tapping mode is specified

M29 (miscellaneous function for preparation for rigid tapping) and S**** specify rigid tapping mode. When M29 is accepted by the PMC, the following processing must be performed:

- Stop the spindle when it is rotating.
- Check that the spindle has stopped completely, then set the rigid tapping signal RGTAP <G061#0> to on.
- Activate the spindle motor. Activate the motor so that a positive speed command rotates the spindle in the forward direction (CCW when viewed from the – side of the tapping axis).
- Return FIN at least 250 ms after activation.

NOTE

The condition "at least 250 ms after activation" results from there being no way of checking the completion of spindle motor activation. Therefore, this wait period serves as an alternative. The time required for activation to be completed varies with the spindle motor and amplifier. Therefore, this value of 250 ms is given as a guideline only.

In an M29 block, S**** is not executed, merely being read in. S**** is executed in a G84 block. Spindle output is equivalent to the specification of S0.

The timing chart is shown in the chart indicating the execution of G84 (G74).

Execution of G84 (G74)

When M29S****; is specified, S**** is read in, spindle output being equivalent to the specification of S0;. S**** is output when G84 (G74) is executed. Thus, the processing described below is performed.

- **When M-type gear selection is used**

When using a machine that features multiple gear stages for use with the spindle motor and spindle, and the newly programmed S**** is outside the previously selected gear range, the spindle-speed function strobe signal SF <F007#2> and gear selection signals (output) GR3O, GR2O, GR1O <F034#2, #1, #0> are output to the PMC.

At this time, perform gear switching at the PMC.

- **When T-type gear selection is used**

The spindle-speed function strobe signal SF <F007#2> and spindle-speed function code signals S00 to S31 <F022 to F025> are output to the PMC. (However, parameter setting is required to enable output of the S codes and SF signal. See the description of each bit of parameter No. 3705.)

At this time, the PMC must determine whether gear switching is to be performed, and perform gear switching as required. The selected gear must be reflected in the gear selection signals (input) GR2 and GR1 <G028#2, #1> for notification to the CNC.

From GR2 and GR1, the CNC determines which gear is selected.

However, note the difference between the M series and T series, as described below.

M series: Up to three gear stages are supported. If the fourth gear stage is selected, it is assumed that the third gear stage is selected.

T series: Up to four gear stages are supported for the first spindle, and up to two gear stages for the second spindle/third spindle. (In the T series and M series, the gear selection for the second spindle/third spindle is notified to the CNC by the signal GR21 <G029#0>/GR31 <G029#2>.)

An S code is output in the first block (positioning to tapping position) of G84 (G74) execution. However, the spindle motor position loop is closed in the next block (R point positioning). Accordingly, spindle speed offset must be adjusted accurately until the position loop has been closed in the second block of G84 (G74) execution after the PMC activates the spindle motor with M29. Otherwise, the spindle motor may rotate slightly. (This applies only to an analog spindle. No offset adjustment is required for a serial spindle.)

Rigid tapping mode may be specified by specifying M29 before G84, specifying M29 and G84 in the same block, or by specifying G84 as a G code for rigid tapping. In each case, PMC processing is the same. (The M29 code is always output.)

9.11.7 Timing Charts for Rigid Tapping Specification

The timing chart for rigid tapping specification depends on the method used to specify rigid tapping mode, the gear selection method (M-type or T-type), and whether to perform gear switching.

From the table, find the appropriate timing chart (Fig. 9.11.7.1 (a) to Fig. 9.11.7.3 (d)) and apply the information it contains as necessary.

Gear selection method M-type T-type	Gear switching	Specification method		
		M29 is specified before G84 (G74).	M29 and G84 (G74) are specified in the same block.	By parameter setting, G84 (G74) is specified as a G code for rigid tapping.
M-type	Not performed	Fig. 9.11.7.1 (a)	Fig. 9.11.7.2 (a)	Fig. 9.11.7.3 (a)
	Performed	Fig. 9.11.7.1 (b)	Fig. 9.11.7.2 (b)	Fig. 9.11.7.3 (b)
T-type	Not performed	Fig. 9.11.7.1 (c)	Fig. 9.11.7.2 (c)	Fig. 9.11.7.3 (c)
	Performed	Fig. 9.11.7.1 (d)	Fig. 9.11.7.2 (d)	Fig. 9.11.7.3 (d)

NOTE

For more information about the M/T type gear selection method, see Section 9.3 SPINDLE CONTROL. Note the following:

T series: T-type only

M series: M-type when constant surface speed control is not being used and bit 4 (GTT) of parameter No. 3706 is set to 0

T-type when constant surface speed control is being used, or bit 4 (GTT) of parameter No. 3706 is set to 1

9.11.7.1

When M29 is specified before G84 (G74)

M type gear selection method

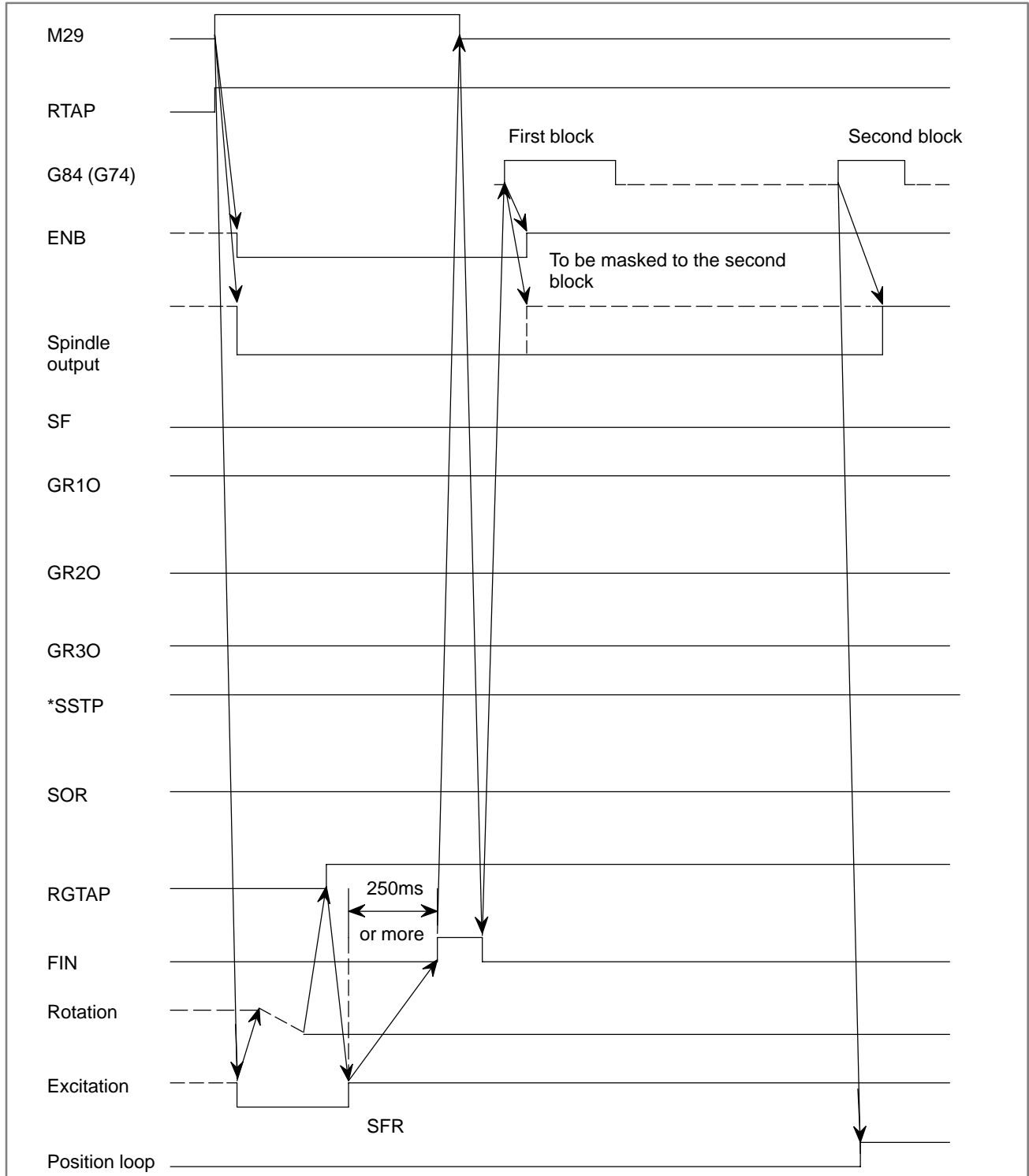

Fig. 9.11.7.1 (a) Gear is not changed

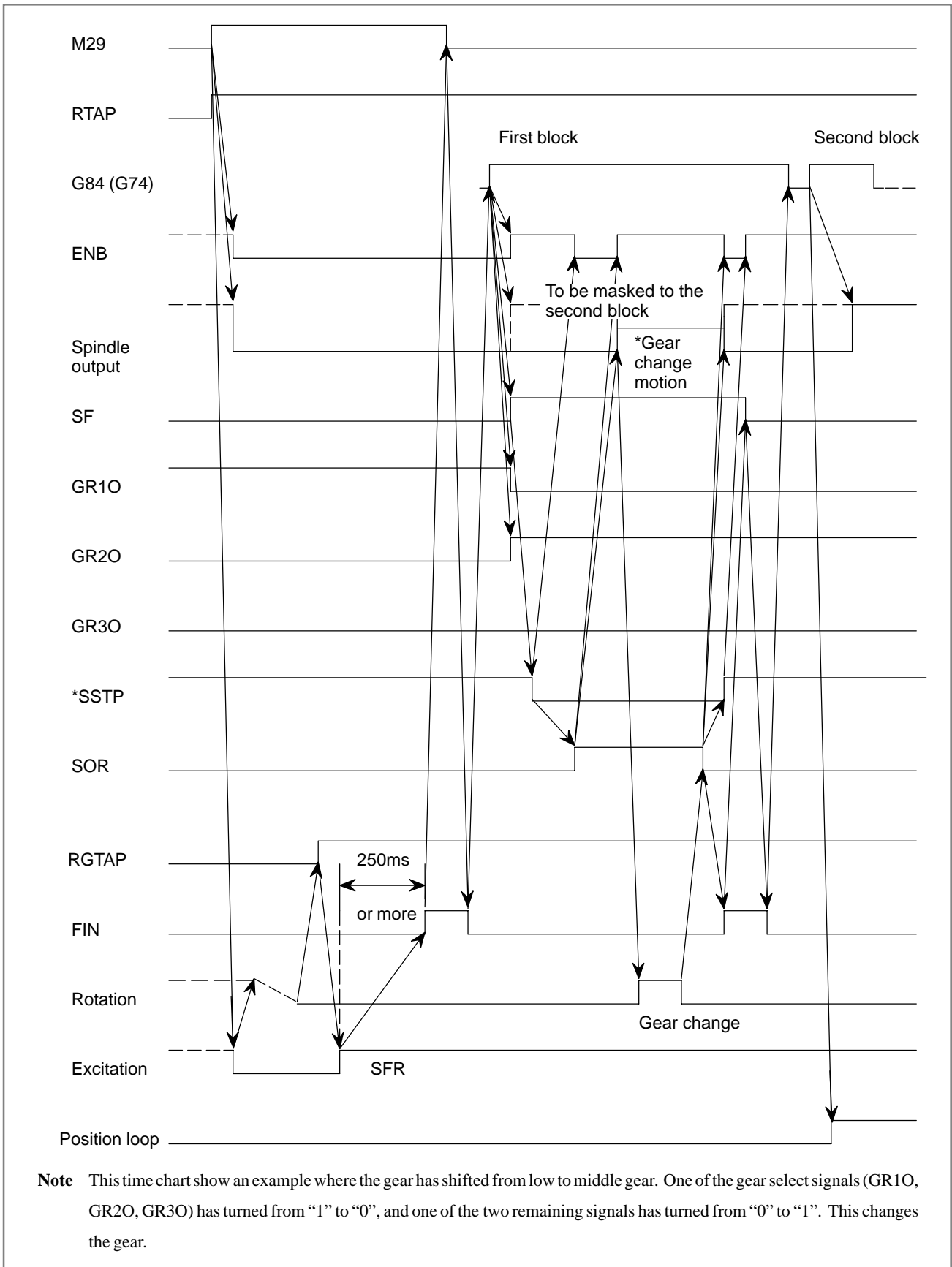

Fig. 9.11.7.1 (b) When gear change is performed (from low to middle gear)

T type gear selection method

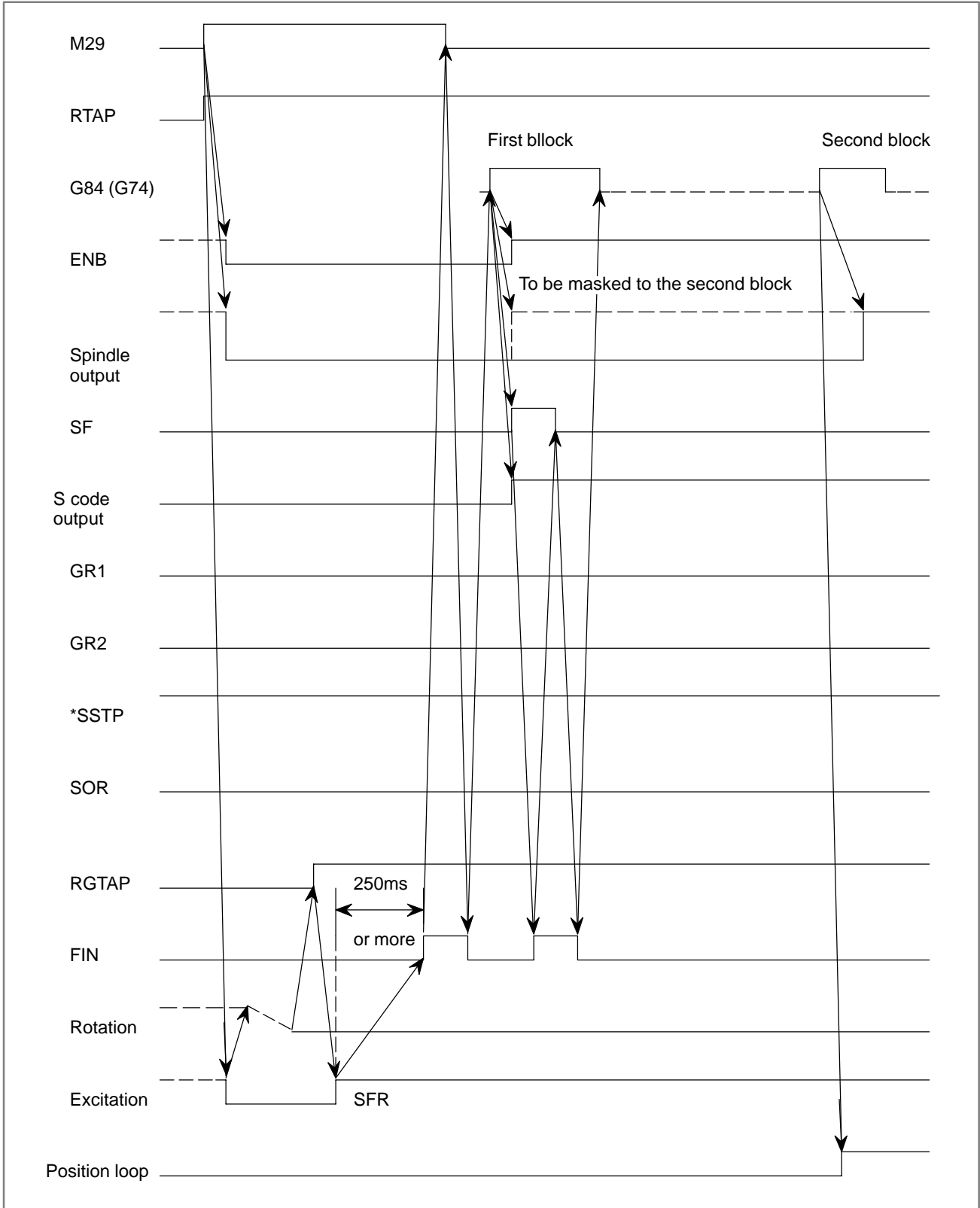

Fig. 9.11.7.1 (c) Gear change is not performed

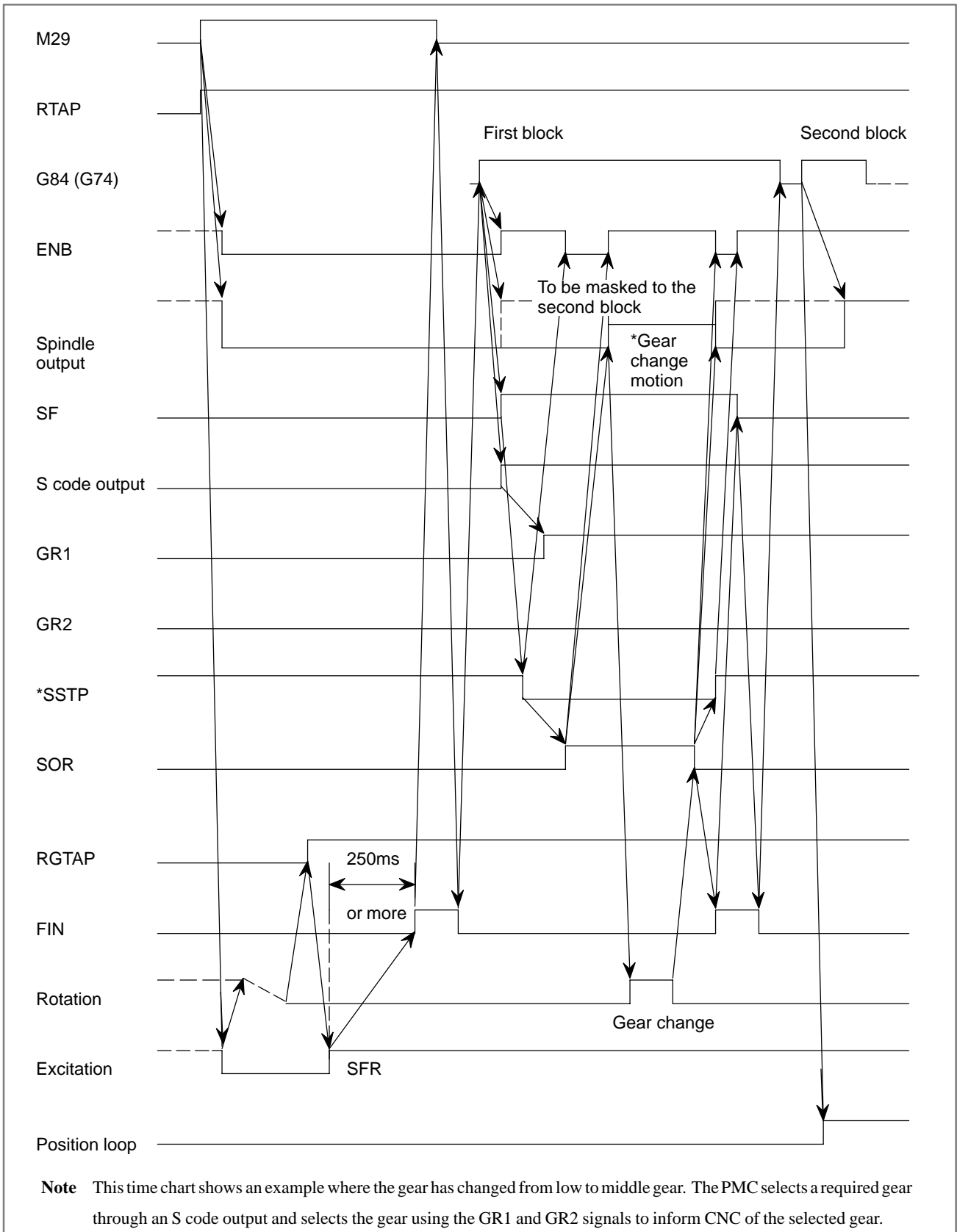

Fig. 9.11.7.1 (d) When gear-change is performed (low to middle gear)

9.11.7.2

M29 and G84 (G74) are specified in the same block

M type gear selection

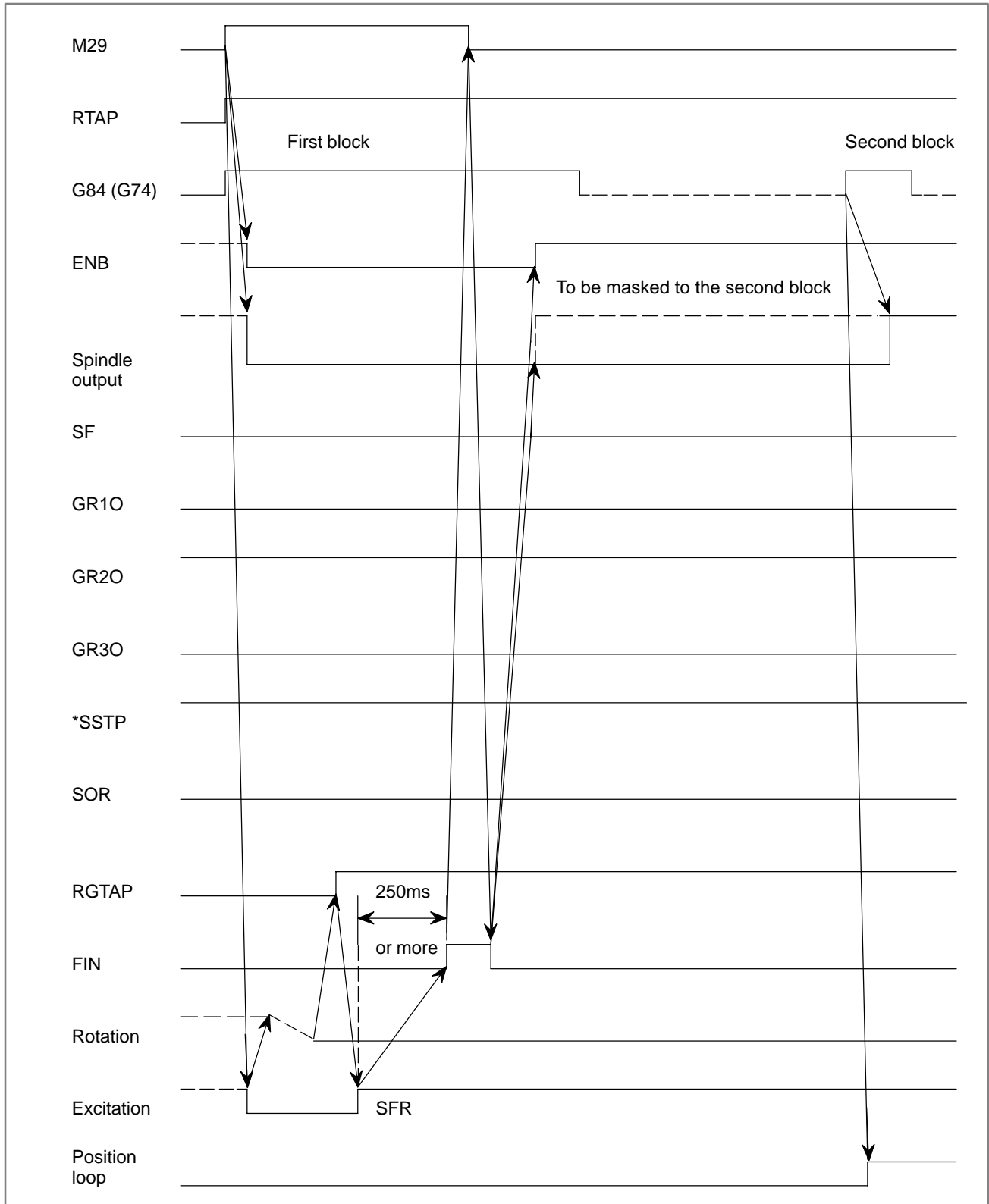

Fig. 9.11.7.2 (a) When gear-change is not performed

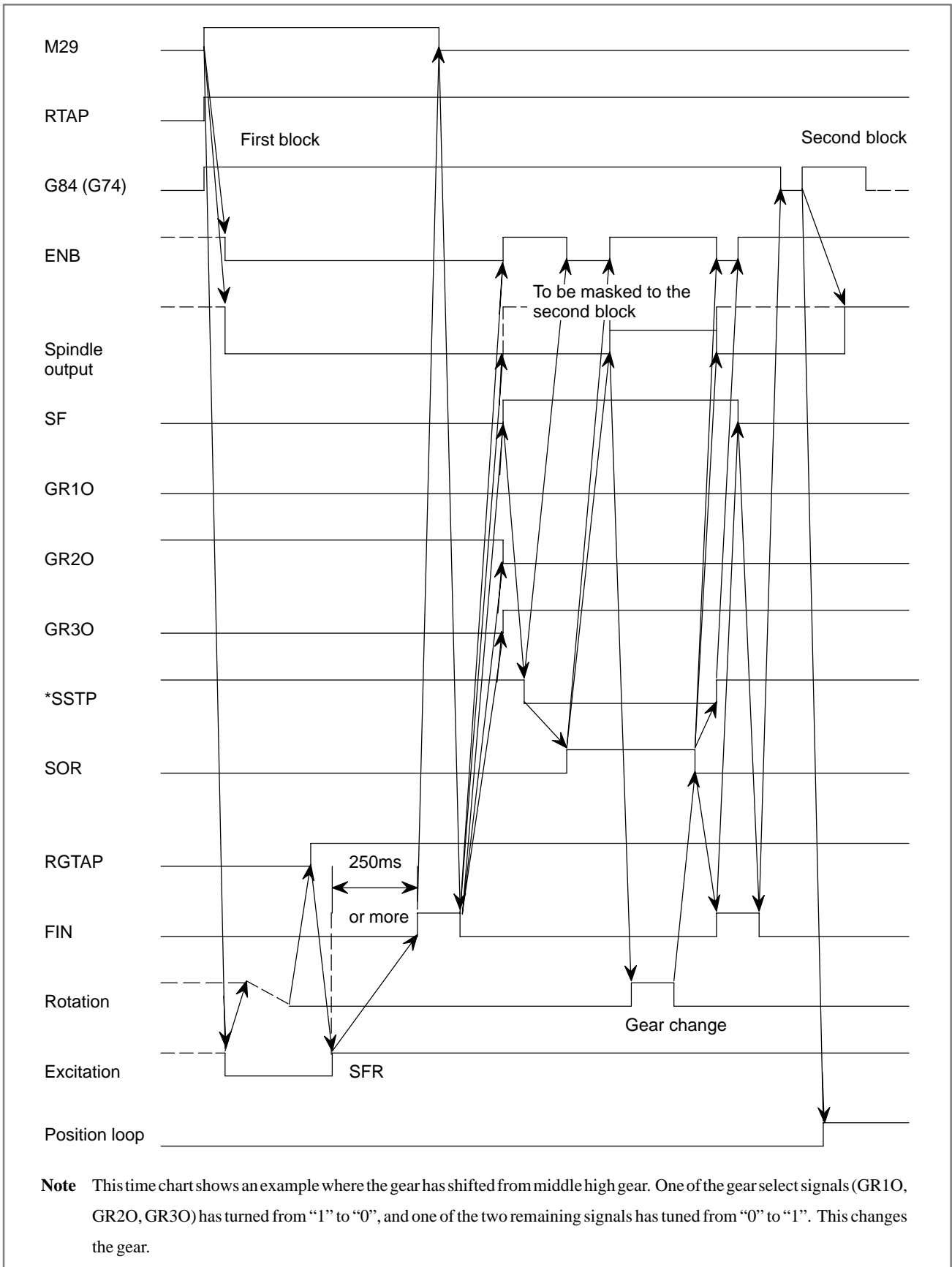

Fig. 9.11.7.2 (b) When gear-change is performed (middle to high)

T type gear selection method

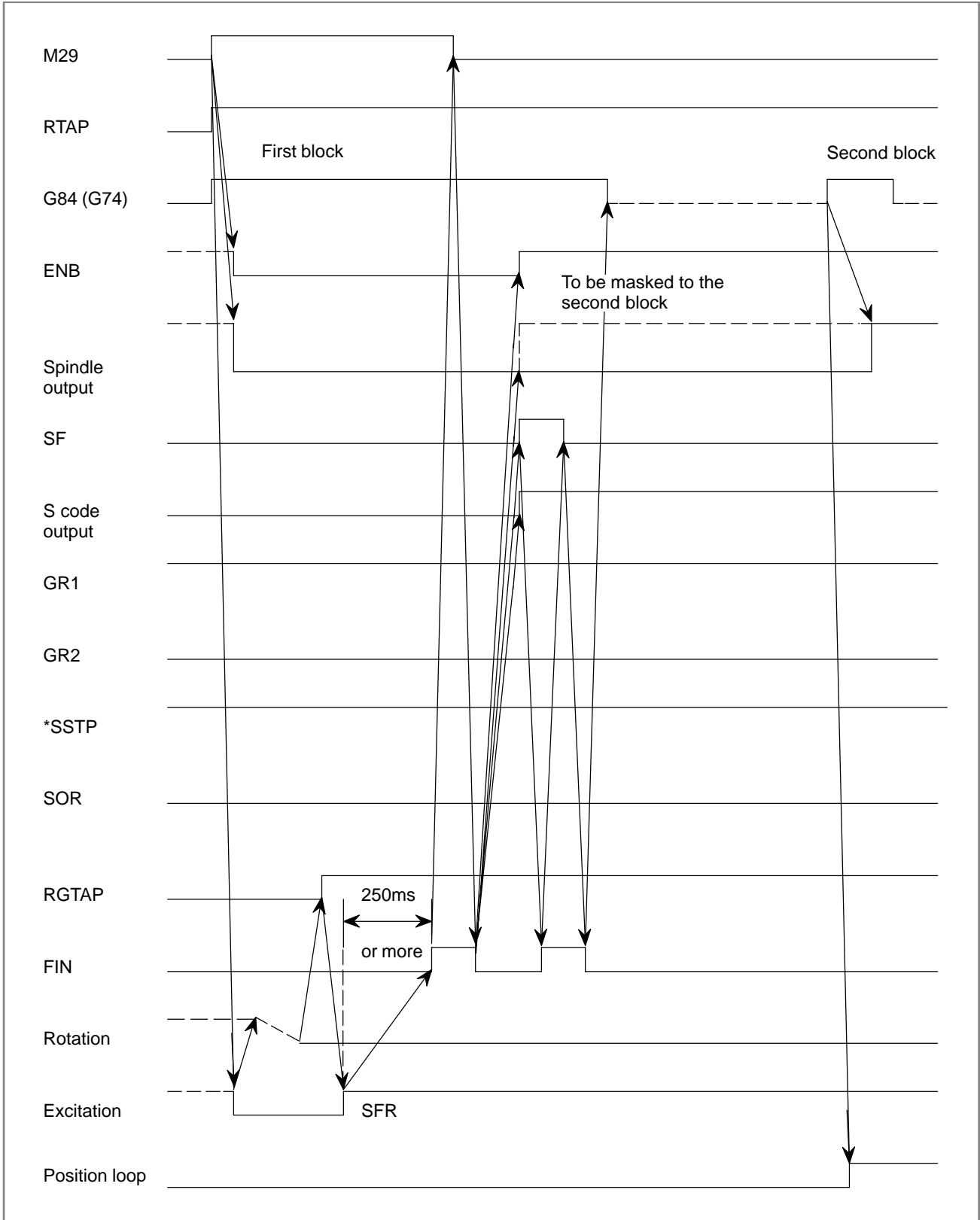

Fig. 9.11.7.2 (c) When gear change is not performed

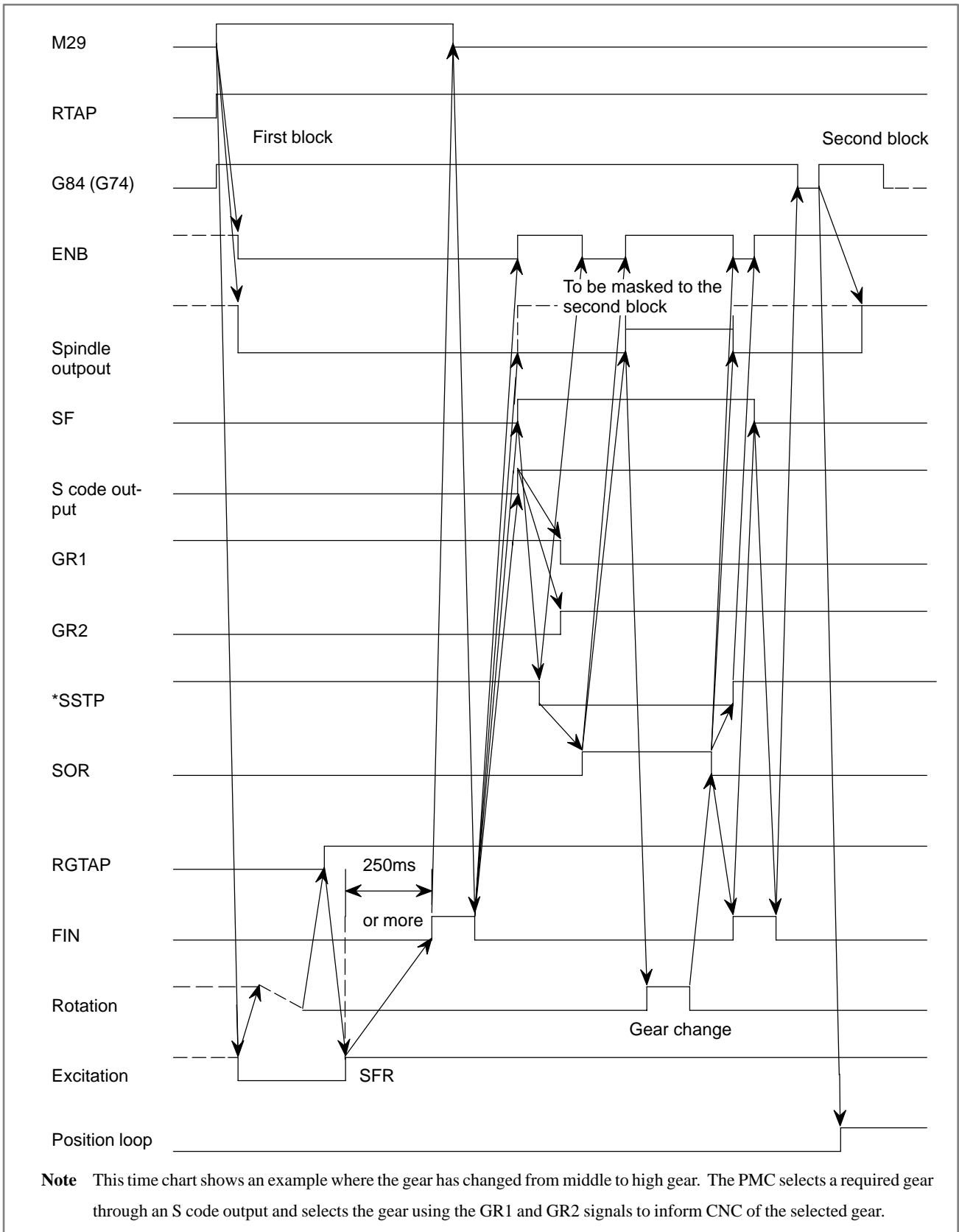

Fig 9.11. 7.2 (d) When gear-change is performed (middle to high gear)

9.11.7.3

Specifying G84 (G74) for rigid tapping by parameters

M type gear selection

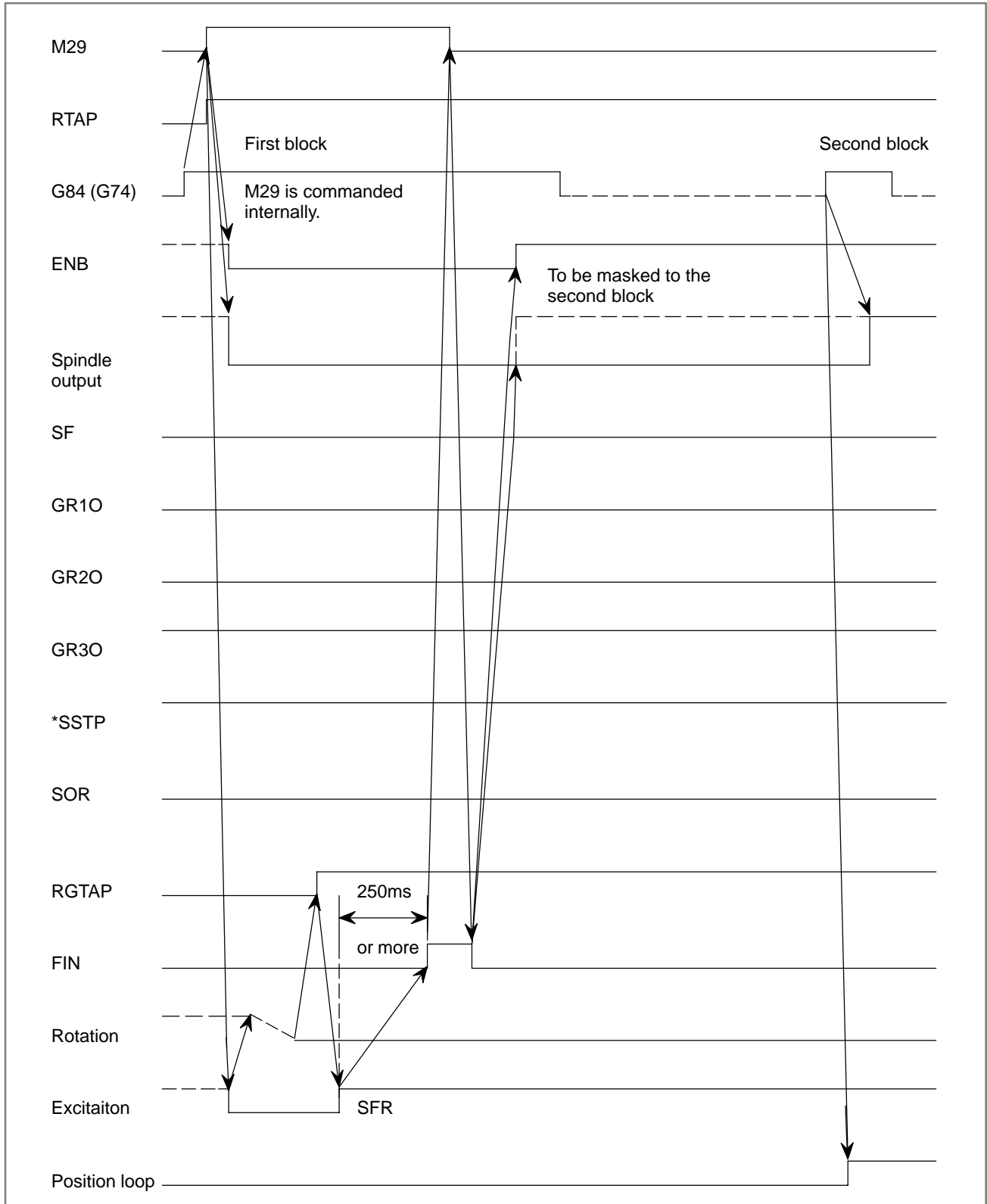

Fig. 9.11.7.3 (a) When gear-change is not performed

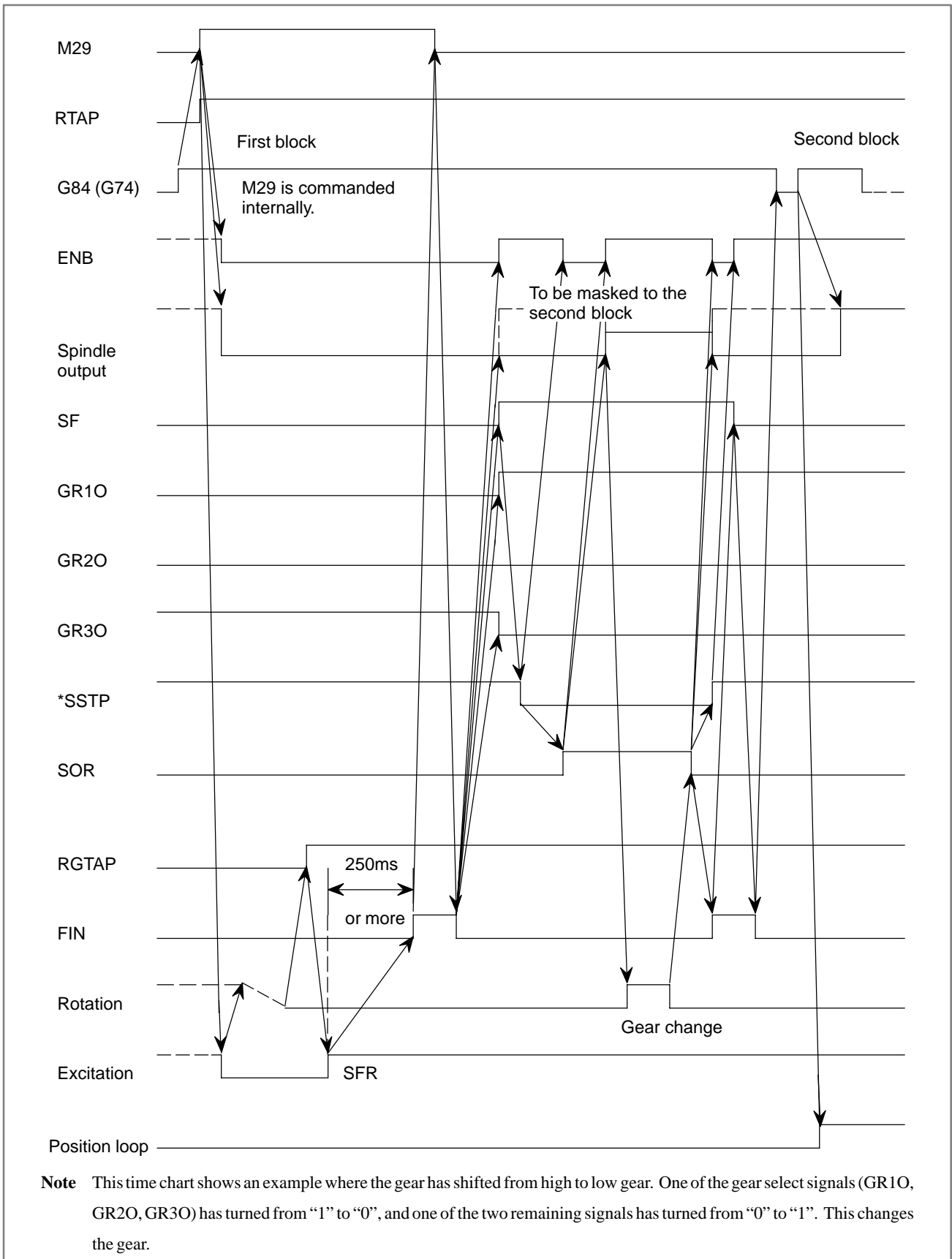

Fig. 9.11.7.3 (b) When gear change is performed (high to low gear)

T type gear selection method

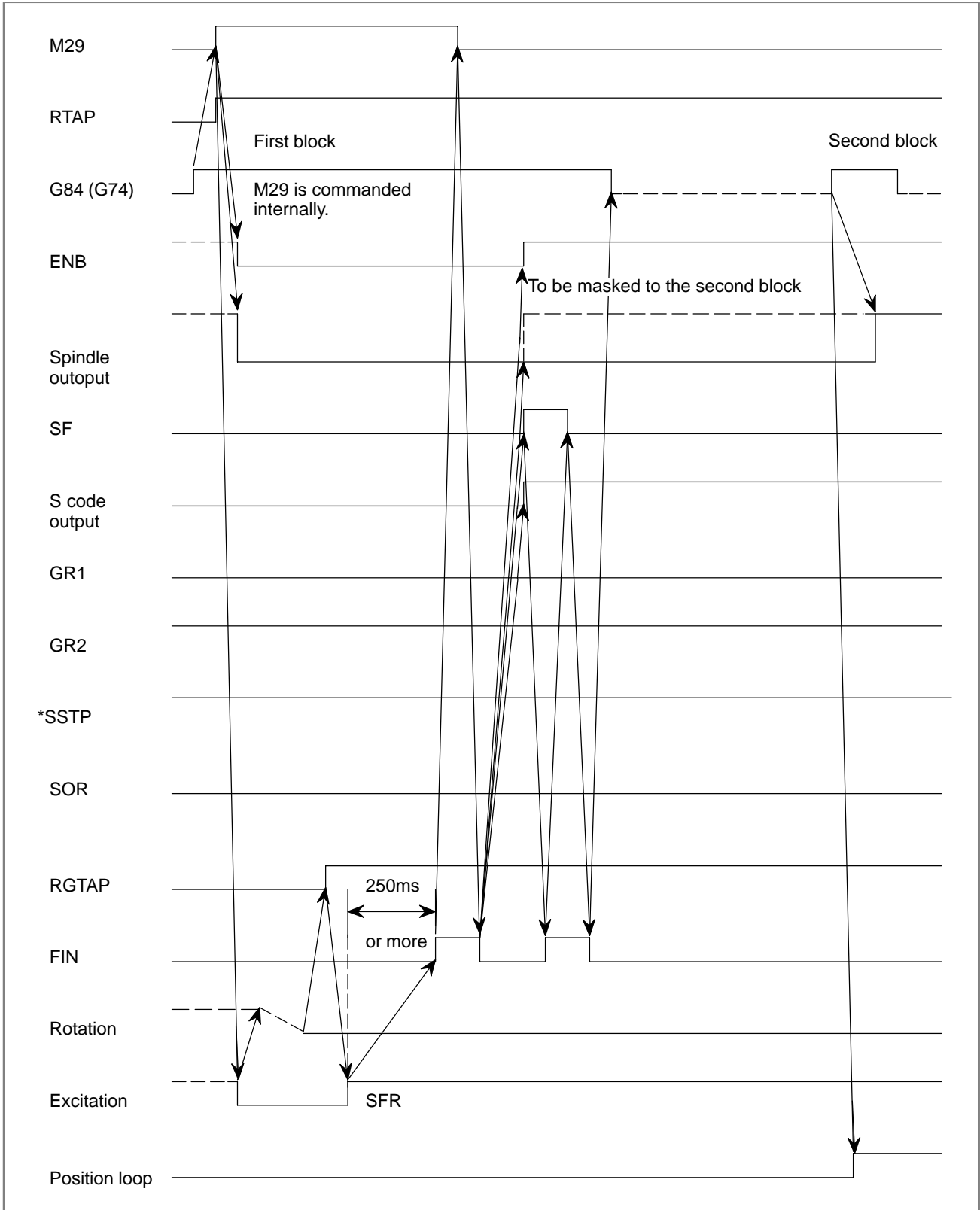

Fig. 9.11.7.3 (c) When gear change is not performed

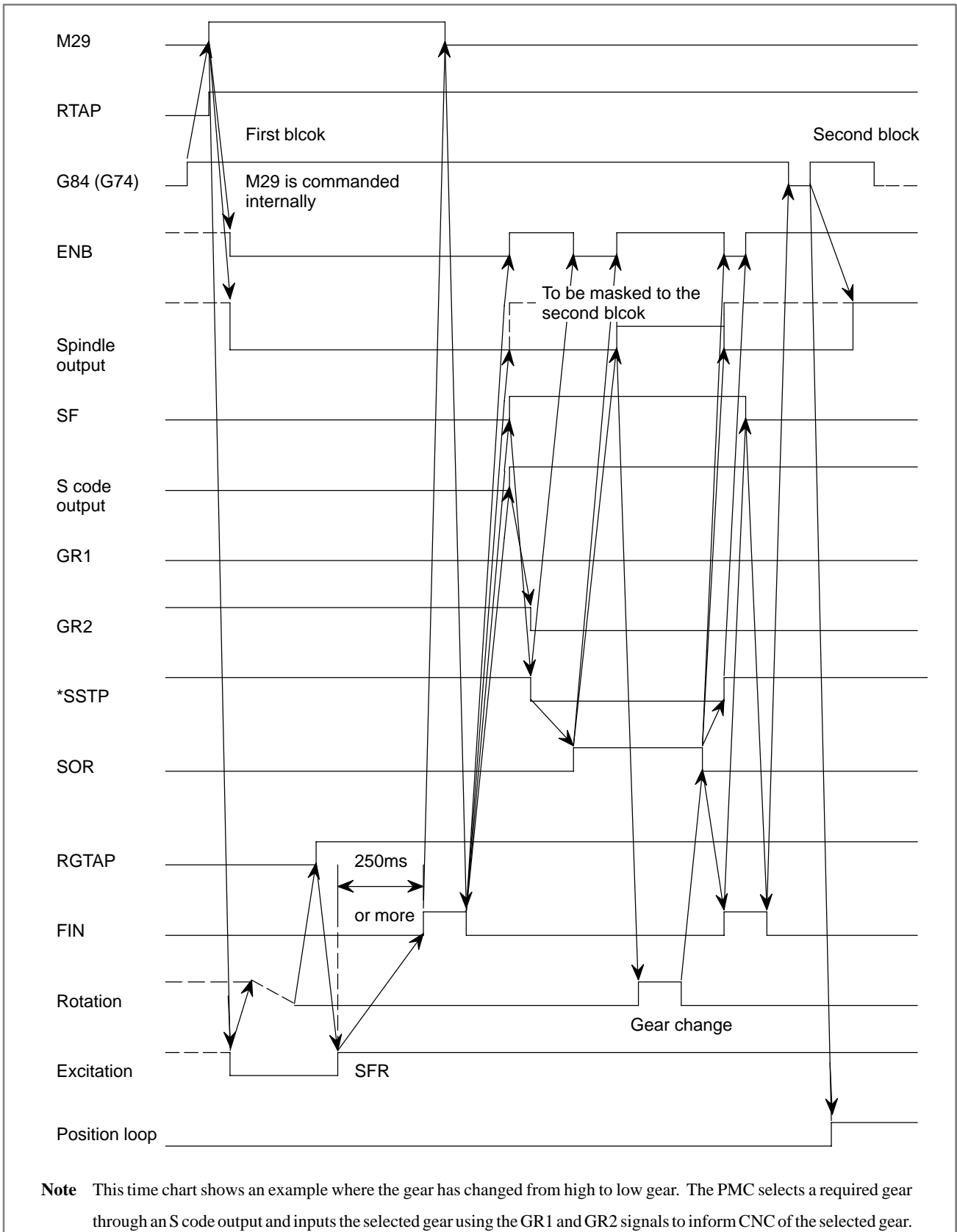

Fig. 9.11.7.3 (d) When gear-change is performed (high to low gear)

**9.11.7.4
Timing to cancel rigid tapping mode**

When rigid tapping is completed, the mode is canceled if a G code (such as G80, canned cycle G code, or Group 01 G code) is issued. The S command used during rigid tapping is automatically cleared when rigid mode is cancelled. This reduces the spindle output to 0, placing the system in the state in which the S0 command is specified. Cancel the PMC rigid tapping mode at the falling edge of the ENB signal (ENB2/ENB3 signal for 2nd spindle/3rd spindle) by de-energizing the spindle; then turn off the rigid tapping mode signal. The system goes to the next block after confirming that the signal is off.

When gear change is performed using *SSTP and SOR, the ENB signal can be either “1” or “0”. Do not cancel the PMC’s rigid tapping mode at the falling edge of the ENB signal under these circumstances. The position loop is also canceled.

When the CNC is reset, the PMC’s rigid tapping mode must be canceled. When CRG (parameter No. 5200#2) is “1”, the system goes directly to the next block without checking that the rigid tapping signal is “0”. Set CRG to “1” for systems in which the rigid tapping signal is always “1”.

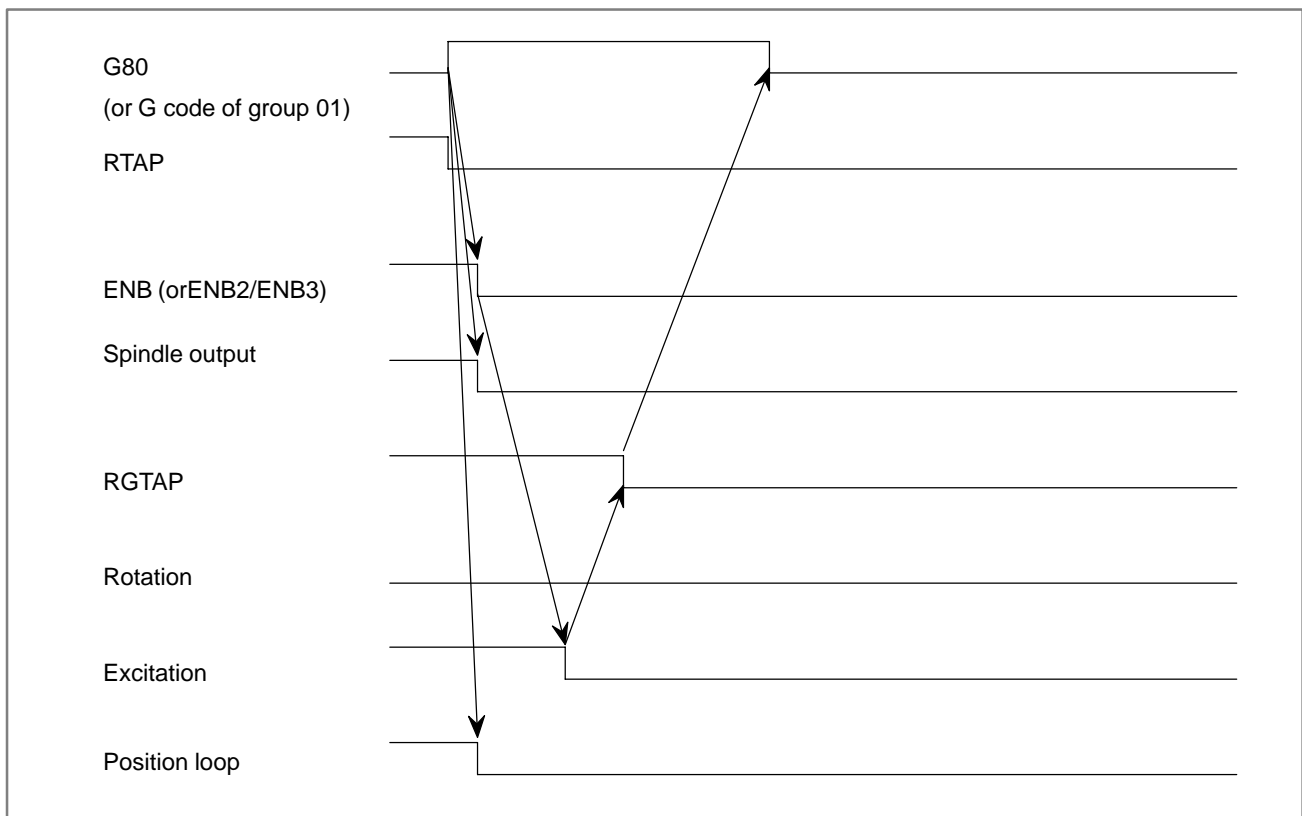

WARNING

- 1 If rigid tapping mode is canceled by a Group 01 G code, such as G00 or G01, the block containing the G code is executed at the same time the ENB signal is turned to "0". Therefore, if the block contains an M code for controlling the spindle, an error may occur during processing in the PMC.
- 2 When CRG (Parameter No. 5200#2) is 1, if the next block contains an M code for controlling the spindle, an error may occur during processing in the PMC, when:
 - Rigid tapping mode is canceled by issuing G80
 - Rigid tapping mode is canceled by issuing a Group 01 G code , such as G00 or G01

NOTE

Rigid tapping mode is canceled as described above regardless of the gear selection method of M-type or T-type.

9.11.8

Parameter

	#7	#6	#5	#4	#3	#2	#1	#0
3705				EVS				ESF
		SFA	NSF		SGT			ESF

[Data type] Bit

ESF When the spindle control function (S analog output or S serial output) is used, and the constant surface speed control function is used or bit 7 (GTT) of parameter No. 3705 is set to 1:

0 : S codes and SF are output for all S commands.

1 : S codes and SF are not output for an S command in constant surface speed control mode (G96 mode) or for an S command used to specify maximum spindle speed clamping (G50S—;).

NOTE

For the T series, this parameter is enabled when bit 4 (EVS) of parameter No. 3705 is set to 1.

For the M series, SF is not output:

- For an S command used to specify maximum spindle speed clamping (G92S—;) in constant surface speed control mode
- When bit 5 (NSF) of parameter No. 3705 is set to 1

SGT Gear switching method during tapping cycle (G84, G74)

0 : Method A (Same as normal gear switching method)

1 : Method B (Gears are switched during tapping cycle according to the spindle speed set in parameters 3761 and 3762)

EVS When the spindle control function (S analog output or S serial output) is used, S codes and SF are:

0 : Not output for an S command.

1 : Output for an S command.

NOTE

The output of S codes and SF for an S command in constant surface speed control mode (G96), or for an S command used to specify maximum spindle speed clamping (G50S—;) depends on the setting of bit 0 (ESF) of parameter No. 3705.

NSF: When an S code command is issued in constant surface-speed control,

0 : SF is output.

1 : SF is not output:

SFA: The SF signal is output:

0 : When gears are switched

1 : Irrespective of whether gears are switched

3706	#7	#6	#5	#4	#3	#2	#1	#0
				GTT			PG2	PG1

[Data type] Bit

PG2, PG1 Gear ratio of spindle to position coder

Magnification	PG2	PG1
× 1	0	0
× 2	0	1
× 4	1	0
× 8	1	1

Magnification =

$$\frac{\text{Number of spindle revolutions}}{\text{Number of position coder revolutions}}$$

GTT Selection of a spindle gear selection method

- 0: Type M
- 1 : Type T

NOTE

1 Type M:

The gear selection signal is not entered. In response to an S command, the CNC selects a gear according to the speed range of each gear specified beforehand in a parameter. Then the CNC reports the selection of a gear by outputting the gear selection signal. The spindle speed corresponding to the gear selected by the gear selection signal is output.

Type T:

The gear selection signal is entered. The spindle speed corresponding to the gear selected by this signal is output.

- 2 When the constant surface speed control option is selected, type T is selected, regardless of whether this parameter is specified.

3761	Spindle speed when switching from gear 1 to gear 2 during tapping
------	---

3762	Spindle speed when switching from gear 2 to gear 3 during tapping
------	---

[Data type] Word

[Unit of data] min⁻¹

[Valid data range] 0 to 32767

When method B is selected (SGT,#3 of parameter 3705, is set to 1) for the tapping cycle gear switching method, set the spindle speed when the gears are switched.

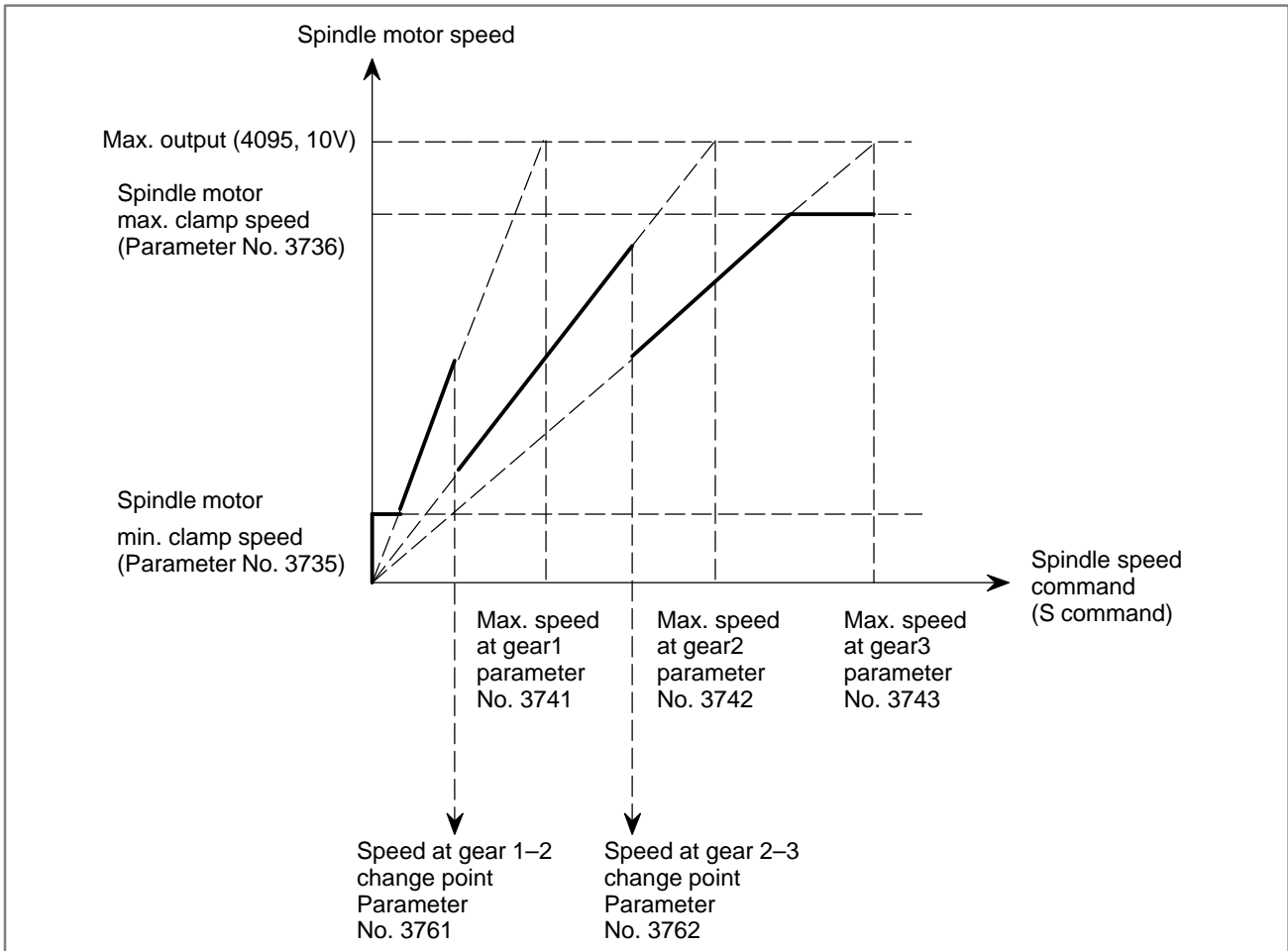

	#7	#6	#5	#4	#3	#2	#1	#0
5101								
								FXY

[Data type] Bit

FXY The drilling axis in the drilling canned cycle is:

0 : Always the Z-axis

1 : The axis selected by the program

NOTE

For the M series, this parameter enables rigid tapping by using a basic axis (X, Y, or Z) perpendicular to the program-selected plane, or an axis parallel to that basic axis, as the tapping axis.

	#7	#6	#5	#4	#3	#2	#1	#0
5200	SRS	FHD		DOV	SIG	CRG	VGR	G84
		FHD	PCP	DOV	SIG	CRG	VGR	G84

[Data type] Bit**G84** Method for specifying rigid tapping

0 : An M code specifying the rigid tapping mode is specified prior to the issue of the G84 (or G74) command. (See parameter No.5210).

1 : An M code specifying the rigid tapping mode is not used. (G84 cannot be used as a G code for the tapping cycle; G74 cannot be used for the reverse tapping cycle.)

VGR Any gear ratio between spindle and position coder in rigid tapping

0 : Not used (The gear ratio is set in parameter No.3706.)

1 : Used (The gear ratio is set by parameters Nos. 5221 through 5224 and 5231 through 5234.)

NOTE

For serial spindles, set this parameter to 0 when using the DMR function for position coder signals on the spindle side.

CRG Rigid mode when a rigid mode cancel command is specified (G80, G01 group G code, reset, etc.)

0 : Canceled after rigid tapping signal RGTAP is set to "0".

1 : Canceled before rigid tapping signal RGTAP is set to "0".

SIG When gears are changed for rigid tapping, the use of SIND <G032 and G033> is

0 : Not permitted.

1 : Permitted.

DOV Override during extraction in rigid tapping

0 : Invalidated

1 : Validated (The override value is set in parameter No.5211.)

PCP Rigid tapping

0 : Used as a high-speed peck tapping cycle

1 : Not used as a high-speed peck tapping cycle

FHD Feed hold and single block in rigid tapping

0 : Inhibited

1 : Enabled

SRS To select a spindle used for rigid tapping in multi-spindle control:

0 : The spindle selection signals SWS1 and SWS2 (bits 0 and 1 of G027) are used. (These signals are used also for multi-spindle control.)

1 : The rigid tapping spindle selection signals RGTSP1 and RGTSP2 (bits 4 and 5 of G061) are used. (These signals are provided expressly for rigid tapping.)

	#7	#6	#5	#4	#3	#2	#1	#0
5201				OV3	OVU	TDR		
				OV3	OVU	TDR		NIZ

[Data type] Bit

NIZ Smoothing in rigid tapping is:

0 : Not performed.

1 : Performed.

TDR Cutting time constant in rigid tapping

0 : Uses a same parameter during cutting and extraction (Parameter Nos. 5261 through 5264)

1 : Not use a same parameter during cutting and extraction

Parameter Nos. 5261 to 5264: Time constant during cutting

Parameter Nos. 5271 to 5274: Time constant during extraction

OVU The increment unit of the override parameter (No.5211) for tool rigid tapping extraction is:

0 : 1%

1 : 10%

OV3 A spindle rotation speed for a pull-out operation is specified by program, so the tool is pulled out while the spindle is rotating at the specified spindle rotation speed.

0 : Disabled.

1 : Enabled.

	#7	#6	#5	#4	#3	#2	#1	#0
5202								
								ORI

NOTE

When this parameter is set, the power must be turned off before operation is continued.

[Data type] Bit

ORI When rigid tapping is started:

0 : Spindle orientation is not performed.

1 : Spindle orientation is performed.

NOTE

This parameter can be used only for a serial spindle.

	#7	#6	#5	#4	#3	#2	#1	#0
5203				OVS	RGS			
			RBL	OVS		RFF	HRM	HRG

[Data type] Bit

HRG Rigid tapping by the manual handle is:

0 : Disabled.

1 : Enabled.

HRM When the tapping axis moves in the negative direction during rigid tapping controlled by the manual handle, the direction in which the spindle rotates is determined as follows:

- 0 : In G84 mode, the spindle rotates in a normal direction. In G74 mode, the spindle rotates in reverse.
- 1 : In G84 mode, the spindle rotates in reverse. In G74 mode, the spindle rotates in a normal direction.

REF Feed forward during movement from the initial point to point R in rigid tapping is:
 0 : Disabled.
 1 : Enabled.

When this parameter is set, the following function is also enabled:

- When rigid tapping is specified in advanced preview control mode, the system automatically exits from advanced preview control mode and executes rigid tapping. After termination of rigid tapping, the system automatically returns to advanced preview control mode.

RGS When bit 0 (MIF) of parameter No. 1403 is set to 1 and rigid tapping is specified in feed-per-minute mode, the spindle speed becomes:
 0 : 1/1000 of the specified speed.
 1 : 1/1 of the specified speed.

OVS In rigid tapping, override by the feedrate override signal and invalidation of override by the override cancel signal is:
 0 : Disabled.
 1 : Enabled.

Setting this parameter enables override by the feedrate override signal <G012> to be applied for rigid tapping operation (cutting and extraction) in rigid tapping.

The spindle speed override is fixed to 100%, but override is also applied to the spindle speed in synchronization with the feedrate along the tapping axis by feedrate override.

The override cancel signal OVC <bit 4 of G006> and second feedrate override signal <G013> also become available.

NOTE

- 1 When this parameter is set to override the feedrate, override by parameters (see parameters Nos. 5211 (T/M) and 5381 (M)) is disabled.
- 2 Regardless of whether this parameter is set, when feedrate override is disabled by the override cancel signal OVC <bit 4 of G006>, override by parameters (see parameters Nos. 5211 (T/M) and 5381 (M)) is enabled.
- 3 An option is required separately to use the second feedrate override signal <G013>.

RBL As acceleration/deceleration for rigid tapping cutting feed:
 0 : Linear acceleration/deceleration is used.
 1 : Bell-shaped acceleration/deceleration is used.

NOTE

The bell-shaped acceleration/deceleration option for rigid tapping is required.

5204	#7	#6	#5	#4	#3	#2	#1	#0
							SPR	DGN

NOTE
When this parameter is set, the power must be turned off before operation is continued.

[Data type] Bit

DGN On the diagnosis screen:

- 0 : A rigid tapping synchronization error is displayed. (Nos. 455 to 457)
- 1 : An error difference between the spindle and tapping axis is displayed. (Nos. 452 and 453)

SPR In rigid tapping, the parameters are:

- 0 : Not changed on a spindle-by-spindle basis.
- 1 : Changed on a spindle-by-spindle basis.

NOTE
1 When switching between the rigid tapping parameters on a spindle-by-spindle basis in rigid tapping using the second and third serial spindles, set this parameter to 1. The following parameters are supported for each spindle:

First spindle (4-stage gear)	Second spindle (2-stage gear)	Third spindle (2-stage gear)
No.5214	No.5215	No.5216
No.5221 to No.5224	No.5225, No.5226	No.5227, No.5228
No.5231 to No.5234	No.5235, No.5236	No.5237, No.5238
No.5241 to No.5244	No.5245, No.5246	No.5247, No.5248
No.5261 to No.5264	No.5265, No.5266	No.5267, No.5268
No.5271 to No.5274	No.5335, No.5336	No.5337, No.5338
No.5280	No.5341	No.5344
No.5281 to No.5284	No.5342, No.5343	No.5345, No.5346
No.5300, No.5301	No.5302, No.5303	No.5304, No.5305
No.5310 to No.5314	No.5350 to No.5353	No.5354 to No.5357
No.5321 to No.5324	No.5325, No.5326	No.5327, No.5328

2 For rigid tapping using the second and third serial spindles, the multispindle control option is required.

5205	#7	#6	#5	#4	#3	#2	#1	#0
								RCK
						NRV		RCK

[Data type] Bit

RCK In rigid tapping, an excessive error during movement/at stop is:

- 0 : Checked regardless of whether mode is cutting (tapping) or rapid traverse.
- 1 : Checked only in cutting (tapping) mode.

NRV For the rigid tapping function, the spindle returns back from the bottom of a hole with:

- 0 : Rotating opposite to the drilling direction
- 1 : Rotating in the drilling direction (special purpose)

NOTE

When you want to perform rigid tapping, do not set this parameter.

If rigid tapping is performed with this parameter set, a tapping tool, workpiece, or machine may be damaged.

5210

Rigid tapping mode specification M code

[Data type] Byte

[Valid data range] 0 to 255

This parameter sets an M code that specifies the rigid tapping mode.

NOTE

1 The M code is judged to be 29 (M29) when "0" is set.

2 To use an M code whose number is greater than 255, Specify the code number with parameter No.5212.

5211

Override value during rigid tapping extraction

[Data type] Byte

[Unit of data] 1 % or 10 %

[Valid data range] 0 to 200

The parameter sets the override value during rigid tapping extraction.

NOTE

The override value is valid when DOV in parameter No.5200 #4 is "1".

When OVU (bit 3 of parameter No.5201) is 1, the unit of set data is 10%. An override of up to 200% can be applied to extraction.

5212

M code that specifies a rigid tapping mode

[Data type] 2-word

[Unit of data] Integer

[Valid data range] 0 to 65535

This parameter sets the M code that specifies the rigid tapping mode.

The M code that specifies the rigid tapping mode is usually set by parameter 5210. To use an M code whose number is greater than 255, specify the code number with parameter 5212.

NOTE

If the setting of this parameter is 0, the M code specifying the rigid tapping mode is determined by the setting of parameter 5210. Otherwise, it is determined by the setting of parameter 5212. The setting of parameter 5212 must always be within the above valid range.

5213	
	Return or clearance in peck tapping cycle

[Data type] Word

[Unit of data]

Increment system	IS-A	IS-B	IS-C	Unit
Millimeter input	0.01	0.001	0.0001	mm
Input in include	0.001	0.0001	0.00001	inch

[Valid data range] 0 to 32767

This parameter sets the return or clearance in the peck tapping cycle.

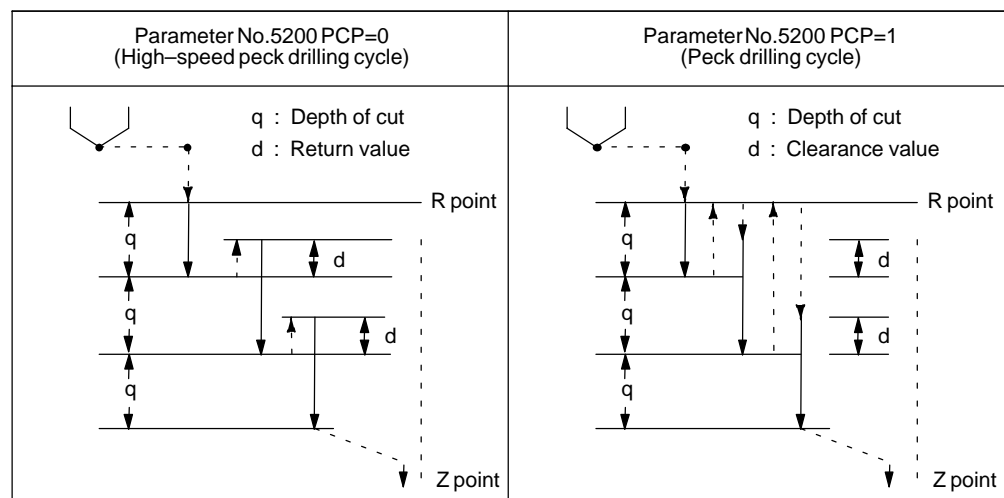

Fig.9.11.8 (a) High-speed Peck Drilling and Peck Drilling Cycles

5214	Setting of an allowable rigid tapping synchronization error range
5215	Setting of an allowable rigid tapping synchronization error range for the second spindle
5216	Setting of an allowable rigid tapping synchronization error range for the third spindle

[Data type] Word

[Unit of data] Detection unit

[Valid data range] 0 to 32767

Each of these parameters is used to set an allowable synchronization error range between a spindle used for rigid tapping and the tapping axis.

If the value set with each parameter is exceeded, rigid tapping alarm No.741 (excessive error during movement) is issued. When 0 is set, a synchronization error check is not made.

NOTE

When rigid tapping is performed using the second and third spindles

- When the SPR parameter (bit 1 of parameter No.5204) is set to 0, the setting of parameter No.5214 is applied to the second and third spindles, as well as to the first spindle.
- When the SPR parameter (bit 1 of parameter No.5204) is set to 1, the settings of parameter No.5215 and No.5216 are applied to the second and third spindles, respectively.

5221	Number of spindle gear teeth (first-stage gear)
5222	Number of spindle gear teeth (second-stage gear)
5223	Number of spindle gear teeth (third-stage gear)
5224	Number of spindle gear teeth (fourth-stage gear)
5225	Number of second spindle gear teeth (first-stage gear)
5226	Number of second spindle gear teeth (second-stage gear)
5227	Number of third spindle gear teeth (first-stage gear)
5228	Number of third spindle gear teeth (second-stage gear)

[Data type] Word

[Valid data range] 1 to 32767

When an arbitrary gear ratio is used in rigid tapping, each of these parameters sets the number of teeth of each spindle gear.

NOTE

- 1 These parameters are enabled when the VGR parameter (bit 1 of parameter No.5200) is set to 1.
- 2 When a position coder is attached to the spindle, set the same value for all of parameters No.5221 through No.5224.
- 3 When the DMR function of the position coder signal is used with a serial spindle, set the VGR parameter (bit 1 of parameter No.5200) to 0, and set these parameters to 0.
- 4 When rigid tapping is performed using the second and third spindles
 - When the SPR parameter (bit 1 of parameter No.5204) is set to 0, the settings of parameters No.5221 and No.5222 are applied to the second and third spindles, as well as to the first spindle.
 - When the SPR parameter (bit 1 of parameter No.5204) is set to 1, the settings of parameters No.5225 and No.5226 are applied to the second spindle, while the settings of parameters No.5227 and No.5228 are applied to the third spindle.

5231	Number of position coder gear teeth (first-stage gear)
5232	Number of position coder gear teeth (second-stage gear)
5233	Number of position coder gear teeth (third-stage gear)
5234	Number of position coder gear teeth (fourth-stage gear)
5235	Number of position coder gear teeth for the second spindle (first-stage gear)
5236	Number of position coder gear teeth for the second spindle (second-stage gear)
5237	Number of position coder gear teeth for the third spindle (first-stage gear)
5238	Number of position coder gear teeth for the third spindle (second-stage gear)

[Data type] Word

[Valid data range] 1 to 32767

When an arbitrary gear ratio is used in rigid tapping, each of these parameters sets the number of teeth of each position coder gear.

NOTE

- 1 These parameters are enabled when the VGR parameter (bit 1 of parameter No.5200) is set to 1.
When a position coder is attached to the spindle, set the same value for all of parameters No.5231 through No.5234. When a spindle motor with a built-in position coder is used, a position coder with a resolution of 2048 pulses/rev may be used. In such a case, set the actual number of teeth, multiplied by 2 (for conversion to 4096 pulses/rev).
- 2 When the DMR function of the position coder signal is used with a serial spindle, set the VGR parameter (bit 1 of parameter No.5200) to 0, and set these parameters to 0.
- 3 When rigid tapping is performed using the second and third spindles
 - When the SPR parameter (bit 1 of parameter No.5204) is set to 0, the settings of parameters No.5231 and No.5232 are applied to the second and third spindles, as well as to the first spindle.
 - When the SPR parameter (bit 1 of parameter No.5204) is set to 1, the settings of parameters No.5235 and No.5236 are applied to the second spindle, while the settings of parameters No.5237 and No.5238 are applied to the third spindle.

5241	Maximum spindle speed in rigid tapping (first-stage gear)
5242	Maximum spindle speed in rigid tapping (second-stage gear)
5243	Maximum spindle speed in rigid tapping (third-stage gear)
5244	Maximum spindle speed in rigid tapping (fourth-stage gear)
5245	Maximum spindle speed in rigid tapping using the second spindle (first-stage gear)
5246	Maximum spindle speed in rigid tapping using the second spindle (second-stage gear)
5247	Maximum spindle speed in rigid tapping using the third spindle (first-stage gear)
5248	Maximum spindle speed in rigid tapping using the third spindle (second-stage gear)

[Data type] 2-word

[Unit of data] min^{-1}

[Valid data range] Spindle position coder gear ratio

1:1 0 to 7400

1:2 0 to 9999

1:4 0 to 9999

1:8 0 to 9999

Each of these parameters is used to set a maximum spindle speed for each gear in rigid tapping.

NOTE

- 1 For the M series, set the same value for both parameter No.5241 and parameter No.5243 for a one-stage gear system. In a system with two gear stages, set parameter No. 5243 with the value specified in parameter No. 5241 or 5242 whichever is greater. Otherwise, P/S alarm No.200 will be issued.
- 2 When rigid tapping is performed using the second and third spindles
 - When the SPR parameter (bit 1 of parameter No.5204) is set to 0, the settings of parameters No.5241 and No.5242 are applied to the second and third spindles, as well as to the first spindle.
 - When the SPR parameter (bit 1 of parameter No.5204) is set to 1, the settings of parameters No.5245 and No.5246 are applied to the second spindle, while the settings of parameters No.5247 and No.5248 are applied to the third spindle.

5261	Linear acceleration/deceleration time constant for the spindle and tapping axis (first-stage gear)
5262	Linear acceleration/deceleration time constant for the spindle and tapping axis (second-stage gear)
5263	Linear acceleration/deceleration time constant for the spindle and tapping axis (third-stage gear)
5264	Linear acceleration/deceleration time constant for the spindle and tapping axis (fourth-stage gear)
5265	Linear acceleration/deceleration time constant for the second spindle and tapping axis (first-stage gear)
5266	Linear acceleration/deceleration time constant for the second spindle and tapping axis (second-stage gear)
5267	Linear acceleration/deceleration time constant for the third spindle and tapping axis (first-stage gear)
5268	Linear acceleration/deceleration time constant for the third spindle and tapping axis (second-stage gear)

[Data type] Word

[Unit of data] ms

[Valid data range] 0 to 4000

Each of these parameters is used to set a linear acceleration/deceleration time constant for the spindle of each gear and the tapping axis in rigid tapping. Set the period required to reach each maximum spindle speed (parameters No.5241 through No.5248). The set time constant, multiplied by the ratio of a specified S value to a maximum spindle speed, is actually used as a time constant.

NOTE

When rigid tapping is performed using the second and third spindles

- When the SPR parameter (bit 1 of parameter No.5204) is set to 0, the settings of parameters No.5261 and No.5262 are applied to the second and third spindles, as well as to the first spindle.
- When the SPR parameter (bit 1 of parameter No.5204) is set to 1, the settings of parameters No.5265 and No.5266 are applied to the second spindle, while the settings of parameters No.5267 and No.5268 are applied to the third spindle.

5271	Time constant for the spindle and tapping axis in extraction operation (first-stage gear)
5272	Time constant for the spindle and tapping axis in extraction operation (second-stage gear)
5273	Time constant for the spindle and tapping axis in extraction operation (third-stage gear)
5274	Time constant for the spindle and tapping axis in extraction operation (fourth-stage gear)

[Data type] Word

[Unit of data] ms

[Valid data range] 0 to 4000

Each of these parameters is used to set a linear acceleration/deceleration time constant for the spindle of each gear and tapping axis in extraction operation during rigid tapping.

NOTE

- 1 These parameters are enabled when the TDR parameter (bit 2 of parameter No.5201) is set to 1.
- 2 When rigid tapping is performed using the second and third spindles
 - When the SPR parameter (bit 1 of parameter No.5204) is set to 0, the settings of parameters No.5271 and No.5272 are applied to the second and third spindles, as well as to the first spindle.
 - When the SPR parameter (bit 1 of parameter No.5204) is set to 1, the settings of parameters No.5335 and No.5336 are applied to the second spindle, while the settings of parameters No.5337 and No.5338 are applied to the third spindle.

5280	Position control loop gain for the spindle and tapping axis in rigid tapping (common to all gears)
5281	Position control loop gain for the spindle and tapping axis in rigid tapping (first-stage gear)
5282	Position control loop gain for the spindle and tapping axis in rigid tapping (second-stage gear)
5283	Position control loop gain for the spindle and tapping axis in rigid tapping (third-stage gear)
5284	Position control loop gain for the spindle and tapping axis in rigid tapping (fourth-stage gear)

NOTE

Once these parameters have been set, the power must be turned off then back on for the settings to become effective.

[Data type] Word

[Unit of data] 0.01 s^{-1}

[Valid data range] 1 to 9999

Each of these parameters is used to set a position control loop gain for the spindle and tapping axis in rigid tapping. These parameters significantly affect the precision of threading. Optimize these parameters as well as the loop gain multipliers by conducting a cutting test.

NOTE

- 1 To use a varied loop gain on a gear-by-gear basis, set parameter No.5280 to 0, and set a loop gain for each gear in parameters No.5281 through No.5284. The specification of a loop gain on a gear-by-gear basis is disabled if parameter No.5280 is set to a value other than 0. In such a case, the value set in parameter No.5280 is used as a loop gain that is common to all the gears.
- 2 When rigid tapping is performed using the second and third spindles
 - When the SPR parameter (bit 1 of parameter No.5204) is set to 0, the setting of parameter No.5280 or the settings of parameters No.5281 and No.5282 are applied to the second and third spindles, as well as to the first spindle.
 - When the SPR parameter (bit 1 of parameter No.5204) is set to 1, the settings of parameters No.5341 through No.5343 are applied to the second spindle, while the settings of parameters No.5344 through No.5346 are applied to the third spindle.

5291	Spindle loop gain multiplier in the rigid tapping mode (for gear 1)
5292	Spindle loop gain multiplier in the rigid tapping mode (for gear 2)
5293	Spindle loop gain multiplier in the rigid tapping mode (for gear 3)
5294	Spindle loop gain multiplier in the rigid tapping mode (for gear 4)

[Data type] Word

[Valid data range] 0 to 32767

Set the spindle loop gain multipliers for gears 1 to 4 in the rigid tapping mode. The thread precision depends on the multipliers. Find the most appropriate multipliers by conducting the cutting test and assign them to the parameters.

NOTE

These parameters are used for analog spindles.

Loop gain multiplier = $2048 \times E/L \times \alpha \times 1000$

where;

E : Voltage in the velocity command at 1000 min⁻¹

L : Degrees of rotation by the spindle per one rotation of the spindle motor

α : Unit used for the detection

Examples

When the spindle motor, spindle, and position coder are connected as shown left, let the variables be as follows:

E = 1.667 (V) (A motor speed of 6000 min⁻¹ corresponds to 10 V.)
 L = 360° (One rotation of the spindle corresponds to one rotation of the spindle motor.)

$\alpha = La/4096$
 = 720°/4096
 = 0.17578

La = 720° (= 360° × 2. One rotation of the position coder corresponds to two rotations of the spindle.)

4096 = The number of detected pulses per rotation of the position coder

Gear ratio between the spindle and the position coder

1:1	0.08789 degrees
1:2	0.17578 degrees
1:4	0.35156 degrees
1:8	0.70313 degrees

According to above ratio the loop gain multiplier is calculated as
 $2048 \times 1.667/360 \times 0.17578 \times 1000 = 1667$

* When the position coder which is built in a spindle motor sends 512 pulses per rotation, the unit used for the detection, α , is La/2048.

Fig.9.11.8 (b) Connection among the spindle motor, spindle, and position coder

5300	Tapping axis in-position width in rigid tapping
5301	Spindle in-position width in rigid tapping

[Data type] Word

[Unit of data] Detection unit

[Valid data range] 1 to 32767

These parameters are used to set tapping axis and spindle in-position widths in rigid tapping.

NOTE

- 1 If an excessively large value is specified, the threading precision will deteriorate.
- 2 When rigid tapping is performed using the second and third spindles
 - When the SPR parameter (bit 1 of parameter No.5204) is set to 0, the settings of parameter No.5300 and No.5301 are applied to the second and third spindles, as well as to the first spindle.
 - When the SPR parameter (bit 1 of parameter No.5204) is set to 1, the settings of parameters No.5302 and No.5303 are applied to the second spindle, while the settings of parameters No.5304 and No.5305 are applied to the third spindle.

5302	Tapping axis in-position width in rigid tapping using the second spindle
5303	Spindle in-position width in rigid tapping using the second spindle

[Data type] Word

[Unit of data] Detection unit

[Valid data range] 0 to 32767

These parameters are used to set spindle and tapping axis in-position widths in rigid tapping using the second spindle.

NOTE

These parameters are enabled when the SPR parameter (bit 1 of parameter No.5204) is set to 1.

5304	Tapping axis in-position width in rigid tapping using the third spindle
5305	Spindle in-position width in rigid tapping using the third spindle

[Data type] Word

[Unit of data] Detection unit

[Valid data range] 0 to 32767

These parameters are used to set spindle and tapping axis in-position widths in rigid tapping using the third spindle.

NOTE

These parameters are enabled when the SPR parameter (bit 1 of parameter No.5204) is set to 1.

5308

In-position width at point R in rigid tapping (tapping axis)

[Data type] Word**[Unit of data]** Detection unit**[Valid data range]** 0 to 32767

This parameter is used to set the tapping axis in-position width at point R in rigid tapping.

5310

Positional deviation limit imposed during tapping axis movement in rigid tapping

[Data type] Word**[Unit of data]** Detection unit**[Valid data range]** 1 to 32767

This parameter is used to set a positional deviation limit during tapping axis movement in rigid tapping. A value that falls outside the valid data range, described above, can be specified in parameter No.5314.

NOTE

- 1 When a high-resolution detector is used, the unit must be multiplied by 10.
- 2 When rigid tapping is performed using the second and third spindles
 - When the SPR parameter (bit 1 of parameter No.5204) is set to 0, the setting of parameter No.5310 (or No.5314) is applied to the second and third spindles, as well as to the first spindle.
 - When the SPR parameter (bit 1 of parameter No.5204) is set to 1, the settings of parameters No.5350 and No.5354 are applied to the second spindle and third spindle, respectively.

5311

Limit value of spindle positioning deviation during movement in rigid tapping.

[Data type] Word**[Unit of data]** Detection unit**[Valid data range]** 1 to 32767

This parameter sets the limit value of a spindle positioning deviation during movement in rigid tapping.

$$\text{Limit value} = S \times 360 \times 100 \times 1.5 / (60 \times G \times \alpha)$$

where

- S : Maximum spindle speed in rigid tapping
(Setting value of parameter Nos. 5241 and greater)
- G : Loop gain of rigid tapping axis
(Setting value of parameter Nos. 5280 and greater)
- α : Detection unit

(Calculation example)

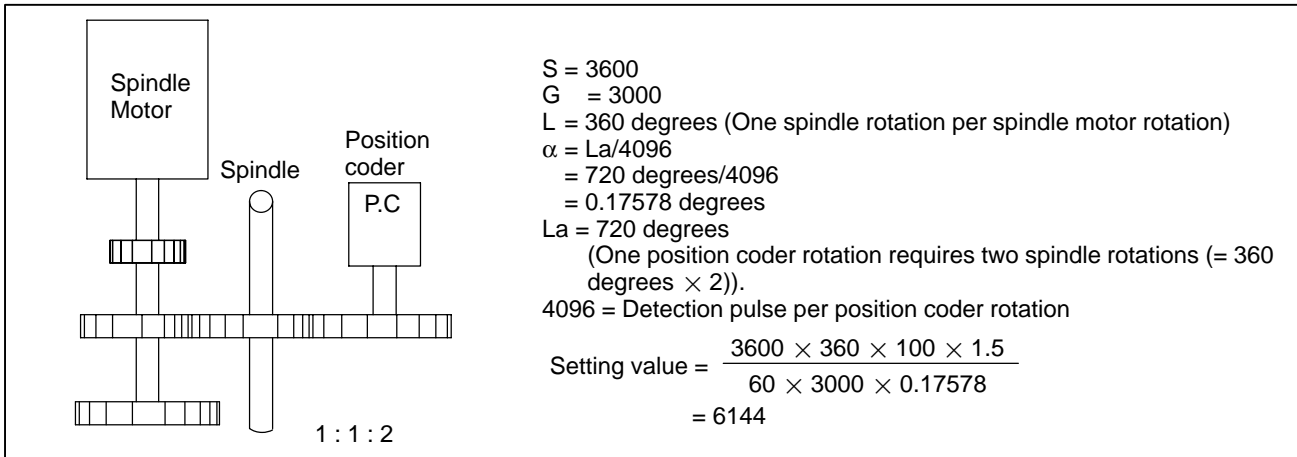

Fig.9.11.8 (c) Connection Among Spindle Motor, Spindle and Position Coder

NOTE

- 1 The detection unit is $\alpha = La/2048$ when the position coder built-in spindle motor uses a position coder of 512 pulses per revolution.
- 2 When rigid tapping is performed using the second and third spindles
 - When the SPR parameter (bit 1 of parameter No.5204) is set to 0, the setting of parameter No.5311 is applied to the second and third spindles, as well as to the first spindle.
 - When the SPR parameter (bit 1 of parameter No.5204) is set to 1, the settings of parameters No.5351 and No.5355 are applied to the second spindle and third spindle, respectively.

5312	Positional deviation limit imposed while the tapping axis is stopped in rigid tapping
------	---

[Data type] Word

[Unit of data] Detection unit

[Valid data range] 1 to 32767

This parameter is used to set a positional deviation limit imposed while the tapping axis is stopped in rigid tapping.

NOTE

- When rigid tapping is performed using the second and third spindles
- When the SPR parameter (bit 1 of parameter No.5204) is set to 0, the setting of parameter No.5312 is applied to the second and third spindles, as well as to the first spindle.
 - When the SPR parameter (bit 1 of parameter No.5204) is set to 1, the settings of parameters No.5352 and No.5356 are applied to the second spindle and third spindle, respectively.

5313

Positional deviation limit imposed while the spindle is stopped in rigid tapping

[Data type] Word**[Unit of data]** Detection unit**[Valid data range]** 1 to 32767

This parameter is used to set a positional deviation limit imposed while the spindle is stopped in rigid tapping.

NOTE

When rigid tapping is performed using the second and third spindles

- When the SPR parameter (bit 1 of parameter No.5204) is set to 0, the setting of parameter No.5313 is applied to the second and third spindles, as well as to the first spindle.
- When the SPR parameter (bit 1 of parameter No.5204) is set to 1, the settings of parameters No.5353 and No.5357 are applied to the second spindle and third spindle, respectively.

5314

Positional deviation limit imposed during tapping axis movement in rigid tapping

[Data type] 2-word**[Unit of data]** Detection unit**[Valid data range]** 0 to 99999999

Usually, parameter No.5310 is used to set a positional deviation limit imposed during tapping axis movement in rigid tapping. However, parameter No.5314 can be used to set a value greater than the valid data range of parameter No.5310 because of the resolution of the detector being used.

NOTE

1 When parameter No.5314 is set to 0, the setting of parameter No.5310 is used. When parameter No.5314 is set to a value other than 0, parameter No.5310 is disabled; in this case, the setting of parameter No.5314 is used.

2 When rigid tapping is performed using the second and third spindles

- When the SPR parameter (bit 1 of parameter No.5204) is set to 0, the setting of parameter No.5314 (or No.5310) is applied to the second and third spindles, as well as to the first spindle.
- When the SPR parameter (bit 1 of parameter No.5204) is set to 1, the settings of parameters No.5350 and No.5354 are applied to the second spindle and third spindle, respectively.

5321	Spindle backlash in rigid tapping (first-stage gear)
	Spindle backlash in rigid tapping
5322	Spindle backlash in rigid tapping (second-stage gear)
5323	Spindle backlash in rigid tapping (third-stage gear)
5324	Spindle backlash in rigid tapping (fourth-stage gear)
5325	Spindle backlash in rigid tapping using the second spindle (first-stage gear)
	Spindle backlash in rigid tapping using the second spindle
5326	Spindle backlash in rigid tapping using the second spindle (second-stage gear)
5327	Spindle backlash in rigid tapping using the third spindle (first-stage gear)
	Spindle backlash in rigid tapping using the third spindle
5328	Spindle backlash in rigid tapping using the third spindle (second-stage gear)

[Data type] Byte

[Unit of data] Detection unit

[Valid data range] 0 to 127

Each of these parameters is used to set a spindle backlash.

NOTE

When rigid tapping is performed using the second and third spindles

- When the SPR parameter (bit 1 of parameter No.5204) is set to 1, the settings of parameters No.5325 and No.5326 are applied to the second spindle, while the settings of parameters No.5227 and No.5228 are applied to the third spindle.
- When the SPR parameter (bit 1 of parameter No.5204) is set to 0, the settings of parameters No.5321 and No.5322 are applied to the second spindle and third spindle, as well as to the first spindle.

5335	Time constant for the spindle and tapping axis in second spindle extraction operation (first-stage gear)
5336	Time constant for the spindle and tapping axis in second spindle extraction operation (second-stage gear)
5337	Time constant for the spindle and tapping axis in third spindle extraction operation (first-stage gear)
5338	Time constant for the spindle and tapping axis in third spindle extraction operation (second-stage gear)

[Data type] Word

[Unit of data] ms

[Valid data range] 0 to 4000

Each of these parameters is used to set a linear acceleration/deceleration time constant for the spindle and tapping axis in extraction operation during rigid tapping on a gear-by-gear basis.

NOTE

This parameter is enabled when both the TDR parameter (bit 2 of parameter No.5201) and the SPR parameter (bit 1 of parameter No.5204) are set to 1.

5341	Position control loop gain for the spindle and tapping axis in rigid tapping using the second spindle (common to all the gears)
5342	Position control loop gain for the spindle and tapping axis in rigid tapping using the second spindle (first-stage gear)
5343	Position control loop gain for the spindle and tapping axis in rigid tapping using the second spindle (second-stage gear)

NOTE

After these parameters have been set, the power must be turned off then back on for the settings to become effective.

[Data type] Word

[Unit of data] 0.01 s^{-1}

[Valid data range] 1 to 9999

Each of these parameters is used to set a position control loop gain for the spindle and tapping axis in rigid tapping using the second spindle.

NOTE

- 1 To use a varied loop gain on a gear-by-gear basis, set parameter No.5341 to 0, and set a loop gain for each gear in parameters No.5342 and No.5343.
- 2 This parameter is enabled when the SPR parameter (bit 1 of parameter No.5204) is set to 1.

5344	Position control loop gain for the spindle and tapping axis in rigid tapping using the third spindle (common to all the gears)
5345	Position control loop gain for the spindle and tapping axis in rigid tapping using the third spindle (first-stage gear)
5346	Position control loop gain for the spindle and tapping axis in rigid tapping using the third spindle (second-stage gear)

NOTE

After these parameters have been set, the power must be turned off then back on for the settings to become effective.

[Data type] Word

[Unit of data] 0.01 s^{-1}

[Valid data range] 1 to 9999

Each of these parameters is used to set a position control loop gain for the spindle and tapping axis in rigid tapping using the third spindle.

NOTE

- 1 To use a varied loop gain on a gear-by-gear basis, set parameter No.5344 to 0, and set a loop gain for each gear in parameters No.5345 and No.5346.
- 2 This parameter is enabled when the SPR parameter (bit 1 of parameter No.5204) is set to 1.

5350	Positional deviation limit imposed during tapping axis movement in rigid tapping using the second spindle
------	---

[Data type] 2-word

[Unit of data] Detection unit

[Valid data range] 1 to 99999999

This parameter sets a positional deviation limit imposed during tapping axis movement in rigid tapping using the second spindle.

NOTE

This parameter is enabled when the SPR parameter (bit 1 of parameter No.5204) is set to 1.

5351	Positional deviation limit imposed during spindle movement in rigid tapping using the second spindle
------	--

[Data type] Word

[Unit of data] Detection unit

[Valid data range] 1 to 32767

This parameter is used to set a positional deviation limit imposed during spindle movement in rigid tapping using the second spindle.

NOTE

This parameter is enabled when the SPR parameter (bit 1 of parameter No.5204) is set to 1.

5352

Positional deviation limit imposed while the tapping axis is stopped in rigid tapping using the second spindle

[Data type] Word**[Unit of data]** Detection unit**[Valid data range]** 1 to 32767

This parameter is used to set a positional deviation limit imposed while the tapping axis is stopped in rigid tapping using the second spindle.

NOTE

This parameter is enabled when the SPR parameter (bit 1 of parameter No.5204) is set to 1.

5353

Positional deviation limit imposed while the spindle is stopped in rigid tapping using the second spindle

[Data type] Word**[Unit of data]** Detection unit**[Valid data range]** 1 to 32767

This parameter is used to set a positional deviation limit imposed while the spindle is stopped in rigid tapping using the second spindle.

NOTE

This parameter is enabled when the SPR parameter (bit 1 of parameter No.5204) is set to 1.

5354

Positional deviation limit imposed during tapping axis movement in rigid tapping using the third spindle

[Data type] 2-word**[Unit of data]** Detection unit**[Valid data range]** 1 to 99999999

This parameter is used to set a positional deviation limit imposed during tapping axis movement in rigid tapping using the third spindle.

NOTE

This parameter is enabled when the SPR parameter (bit 1 of parameter No.5204) is set to 1.

5355	Positional deviation limit imposed during spindle movement in rigid tapping using the third spindle
------	---

[Data type] Word

[Unit of data] Detection unit

[Valid data range] 1 to 32767

This parameter is used to set a positional deviation limit imposed during spindle movement in rigid tapping using the third spindle.

NOTE

This parameter is enabled when the SPR parameter (bit 1 of parameter No.5204) is set to 1.

5356	Positional deviation limit imposed while the tapping axis is stopped in rigid tapping using the third spindle
------	---

[Data type] Word

[Unit of data] Detection unit

[Valid data range] 1 to 32767

This parameter is used to set a positional deviation limit imposed while the tapping axis is stopped in rigid tapping using the third spindle.

NOTE

This parameter is enabled when the SPR parameter (bit 1 of parameter No.5204) is set to 1.

5357	Positional deviation limit imposed while the spindle is stopped in rigid tapping using the third spindle
------	--

[Data type] Word

[Unit of data] Detection unit

[Valid data range] 1 to 32767

This parameter is used to set a positional deviation limit imposed while the spindle is stopped in rigid tapping using the third spindle.

NOTE

This parameter is enabled when the SPR parameter (bit 1 of parameter No.5204) is set to 1.

5365	Bell-shaped acceleration/deceleration time constant for the first spindle in rigid tapping (first-stage gear)
5366	Bell-shaped acceleration/deceleration time constant for the first spindle in rigid tapping (second-stage gear)
5367	Bell-shaped acceleration/deceleration time constant for the first spindle in rigid tapping (third-stage gear)

[Data type] Word

[Unit of data] msec

[Valid data range] 0 to 512

These parameters are used to set bell-shaped acceleration/deceleration time constants for the first spindle in rigid tapping.

5369	Bell-shaped acceleration/deceleration time constant for the second spindle in rigid tapping (first-stage gear)
5370	Bell-shaped acceleration/deceleration time constant for the second spindle in rigid tapping (second-stage gear)

[Data type] Word

[Unit of data] msec

[Valid data range] 0 to 512

These parameters are used to set bell-shaped acceleration/deceleration time constants for the second spindle in rigid tapping.

5373	Bell-shaped acceleration/deceleration time constant for the third spindle in rigid tapping (first-stage gear)
5374	Bell-shaped acceleration/deceleration time constant for the third spindle in rigid tapping (second-stage gear)

[Data type] Word

[Unit of data] msec

[Valid data range] 0 to 512

These parameters are used to set bell-shaped acceleration/deceleration time constants for the third spindle in rigid tapping.

5381	
	Override value during rigid tapping return

[Data type] Byte

[Unit of data] 1% or 10%

[Valid data range] 0 to 200

This parameter is used to set the override value during rigid tapping return.

If the setting is 0, no override is applied.

NOTE

This parameter is valid when bit 4 (DOV) of parameter No. 5200 is set to 1.

If bit 3 (OVU) of parameter No.5201 is set to 1, 10% is set as the units of data. Thus, an override of up to 2000% can be applied during extraction.

5382	
	Amount of return for rigid tapping return

[Data type] 2-word

[Unit of data] Input increments

[Valid data range] 0 to 99999999

During rigid tapping return, the tool can be pulled out, along the tapping axis, going beyond the stored rigid tapping start position by the amount specified with this parameter.

If the tool has already been retracted from rigid tapping, it will be retracted further only by the distance specified in this parameter.

9.11.9 Alarm and Message

Number	Message	Description
200	ILLEGAL S CODE COMMAND	In rigid tapping, an S value is out of the range or is not specified. The maximum value for S which can be specified in rigid tapping is set in parameter (No.5241 to 5243). Change the setting in the parameter or modify the program.
201	FEEDRATE NOT FOUND IN RIGID TAP	In rigid tapping, no F value is specified. Correct the program.
202	POSITION LSI OVERFLOW	In rigid tapping, spindle distribution value is too large.
203	PROGRAM MISS AT RIGID TAPPING	In rigid tapping, position for a rigid M code (M29) or an S command is incorrect. Modify the program.

Number	Message	Description
204	ILLEGAL AXIS OPERATION	In rigid tapping, an axis movement is specified between the rigid M code (M29) block and G84 or G74 block for M series (G84 or G88 block for T series). Modify the program.
205	RIGID MODE DI SIGNAL OFF	<p>1. Although a rigid M code (M29) is specified in rigid tapping, the rigid mode DI signal (DGN G061.0) is not ON during execution of the G84 (G88) block.</p> <p>2. In a system with the multi-spindle option, the spindle used for rigid tapping is not selected (by DI signal G27#0, #1, and #2, or G61#4, #5, and #6 (#6 for T series only)).</p> <p>Check the PMC ladder diagram to find the reason why the DI signal is not turned on.</p>
206	CAN NOT CHANGE PLANE (RIGID TAP)	Plane changeover was instructed in the rigid mode. Correct the program.
207	RIGID DATA MISMATCH	The specified distance was too short or too long in rigid tapping.
410	SERVO ALARM: n-TH AXIS – EXCESS ERROR	The position deviation value when the n-th axis (axis 1–8 of rigid tapping axis) stops is larger than the set value. Note) Limit value must be set to parameter No.5312 for each axis.
411	SERVO ALARM: n-TH AXIS – EXCESS ERROR	The position deviation value when the n-th axis (axis 1–8 of rigid tapping axis) moves is larger than the set value. Note) Limit value must be set to parameter No. 5310 or 5314 for each axis.
413	SERVO ALARM: n-th AXIS – LSI OVERFLOW	The contents of the error register for the n-th axis (axis 1–8 of rigid tapping axis) are beyond the range of -2^{31} to 2^{31} . This error usually occurs as the result of an improperly set parameters.
740	RIGID TAP ALARM; EXCESS ERROR	Position deviation value of spindle at move exceeded a set value during rigid tapping.
741	RIGID TAP ALARM; EXCESS ERROR	Position deviation value of spindle at move exceeded a set value during rigid tapping or synchronous error exceeded a set value (parameter No. 5214) during rigid tapping.
742	RIGID TAP ALARM; LSI OVER FLOW	LSI overflow has occurred on the spindle side during rigid tapping.

9.11.10

Notes

NOTES ON SPINDLES

CAUTION

- 1 When using an analog spindle, set the spindle speed offset value parameter (No. 3731) accurately. For the standard system, a value within –8191 to 8191 must be specified in this parameter. To perform rigid tapping, a value within –1023 to 1023 must be specified.

If the spindle speed offset is set inaccurately, the spindle is stopped and placed in in-position wait state when tapping is started.

In rigid tapping with a serial spindle, no setting is required for parameter No. 3731. Be sure to set 0.

- 2 When the threading and synchronous feed functions are enabled, the actual spindle speed during rigid tapping is indicated correctly. When an arbitrary gear ratio is used (by setting bit 1 (VGR) of parameter No. 5200 to 1), however, the actual spindle speed will not be indicated correctly in normal spindle mode.

When the T series is used, for example, information about the actual spindle speed is important for lathe machining. So, be particularly careful when using an arbitrary gear between the spindle and position coder.

NOTE

- 1 A spindle pitch error is not compensated for in rigid tapping mode. Drift compensation is not made with an analog spindle.

- 2 The maximum number of pulses that can be distributed to the spindle is:

- 32,767 pulses per 8 msec for a serial spindle
- 4,096 pulses per 8 msec for an analog spindle

(This information is displayed by selecting No. 451 on the diagnosis screen.)

These values vary with the position coder gear ratio setting and rigid tapping specification. If a value greater than the maximum allowable number is specified, P/S alarm No. 202 is issued.

Notes on using functions such as the spindle positioning function at the same time

CAUTION

- 1 When the spindle orientation function is to be used at the same time
The spindle orientation function positions the spindle by using sensors and the PMC, without being directly controlled by the CNC.
The CNC has no direct control over this processing, instead following the specifications of the spindle orientation function being used.
- 2 When the spindle positioning function is to be used at the same time
When the spindle positioning function is to be used together with rigid tapping, rigid tapping mode must not be specified in spindle indexing mode, and spindle indexing mode must not be specified in rigid tapping mode. (Spindle positioning and rigid tapping cannot be performed simultaneously for a single spindle.)
This restriction does not apply, however, when multi-spindle control is applied; rigid tapping can be performed using the second spindle.
The spindle positioning function is effective for the first spindle only. This means that when spindle indexing is performed with the first spindle, rigid tapping can be specified with the second spindle.
- 3 When the Cs contouring control function for the serial spindle is used together with the rigid tapping function, the same motor is used for spindle rotation control, Cs contouring control, and rigid tapping modes. The following points must be noted:
 - (1) Whether to enter Cs contouring control mode or spindle rotation control mode is selected by the CON (Cs contouring control switch signal) signal; however, the system can enter rigid tapping mode regardless of the state of the CON signal. When the rigid tapping mode is canceled the system enters spindle rotation control mode or Cs contouring control mode according to the state of the CON signal.
 - (2) Since the system can change to rigid tapping mode directly from the Cs contouring control mode, use of the Cs contouring control function enables the tapping tool to be positioned before rigid tapping begins. Accurate positioning is not guaranteed. If the rigid tapping cycle executes gear change or output range changing, positioning is valid.

CAUTION (continued)

- (3) Although the system can change to rigid tapping mode directly from Cs contouring control mode, positions designated in Cs contouring control mode are not preserved if rigid tapping mode is canceled by G80. When the system is changed to rigid tapping mode from Cs contouring control mode, then returns to the Cs contouring control mode, G00 or G28 must be issued to position the tapping tool.
- (4) In systems with the serial spindle Cs contouring control function, the spindle motor is in a state called servo mode when it is operating in rigid tapping mode. In servo mode, it can accept jogging and manual handling feed. To prevent this, inhibit jogging and manual handling feed of the Cs contouring axis in the PMC logic during rigid tapping.
- (5) The servo-off signal for the Cs contour control axis is valid also for the spindle during rigid tapping. It should be masked on the PMC side as required.
- (6) When the multi-spindle control is also available and the rigid tapping is performed on the 2nd spindle, the rigid tapping can be specified to the 2nd spindle during the Cs contouring control of the 1st spindle.

Position control loop gain switching and serial spindle parameters

In rigid tapping, the loop gain of the tapping axis is switched so that the loop gains for position control of the tapping axis and spindle match each other.

This switching processing is specified by parameter Nos. 5280, and 5281 to 5284. The contents of the processing vary with whether the spindle is an analog or serial spindle, as described below.

- When the spindle is an analog spindle, the loop gains of the spindle and tapping axis are switched according to the values set in these parameters.
- When the spindle is a serial spindle, the loop gain of the tapping axis is switched according to the values set in these parameters. The loop gain of the spindle depends on the values set in the serial spindle parameters and applied gear signals (CTH2, CTH1).

Accordingly, to perform rigid tapping with a serial spindle, the loop gain for position control of the spindle must be set in the serial spindle parameters used for rigid tapping.

When multi-spindle control is being used, rigid tapping can also be performed for the second spindle. For the serial spindle used for rigid tapping, set the parameters indicated below.

The parameters indicated below are the major serial spindle parameters required for the setting and adjustment needed to use a serial spindle.

For details of the serial spindle parameters, refer to the “FANUC AC SPINDLE MOTOR α series PARAMETER MANUAL (B-65160E)” or “FANUC AC SPINDLE MOTOR αi series PARAMETER MANUAL (B-65280EN)”.

4044	Proportional gain of the velocity loop in servo mode (gear 1, gear 2)
4045	Proportional gain of the velocity loop in servo mode (gear 3, gear 4)

[Valid data range] 0 to 32767

Set a proportional gain for the velocity loop in a servo mode (such as rigid tapping mode).

4052	Integral gain of the velocity loop in the servo mode (gear 1, gear 2)
4053	Integral gain of the velocity loop in the servo mode (gear 3, gear 4)

[Valid data range] 0 to 32767

Set an integral gain of the velocity loop in a servo mode (such as rigid tapping mode).

4065	Position gain in the servo mode (HIGH)
4066	Position gain in the servo mode (MEDIUM HIGH)
4067	Position gain in the servo mode (MEDIUM LOW)
4068	Position gain in the servo mode (LOW)

[Unit of data] 0.01 sec⁻¹

[Valid data range] 0 to 65535

Set a servo loop gain in a servo mode (such as rigid tapping mode).

CAUTION

- 1 Set a loop gain for spindle position control in rigid tapping using a serial spindle. In these parameters, basically, set the same values as those set in parameter Nos. 5280 and 5281 to 5284 (loop gains for position control of the tapping axis).

Which serial spindle parameter (i.e., loop gain) is actually used to operate the spindle depends on the serial spindle clutch/gear selection signals CTH1 and CTH2 (G070#3, #2 for the first spindle, and G074#3, #2 for the second spindle). Accordingly, which parameter is to be used must be determined by considering the gear switching and PMC software.

The table below indicates the relationship between the spindle gear selection signals and selected gear numbers.

CTH1	CTH2	Gear selected	Parameter No. to be used		
0	0	HIGH	4065	4044	4052
0	1	MEDIUM HIGH	4066		
1	0	MEDIUM LOW	4067	4045	4053
1	1	LOW	4068		

9.11.11 Rigid-Tapping Bell-Shaped Acceleration/ Deceleration (M Series)

General

Linear acceleration/deceleration and exponential acceleration/deceleration (M series only) have conventionally been applicable to rigid tapping. However, bell-shaped acceleration/deceleration was added recently. Using bell-shaped acceleration/deceleration enables a smaller time constant to be set for rigid tapping, thereby reducing the time required in acceleration/deceleration. Because this bell-shaped acceleration/deceleration is of rapid traverse bell-shaped acceleration/deceleration type, parameters are used to specify a linear acceleration/deceleration time constant and the time for a bell-shaped curved section.

The rigid tapping bell-shaped acceleration/deceleration function is an option.

About bell-shaped acceleration/deceleration

The time required in bell-shaped acceleration/deceleration for rigid tapping is the sum of the linear acceleration/deceleration time constant (value set in the conventional parameter) for the spindle and tapping axis and the time (value set in the new parameter) for a curved section.

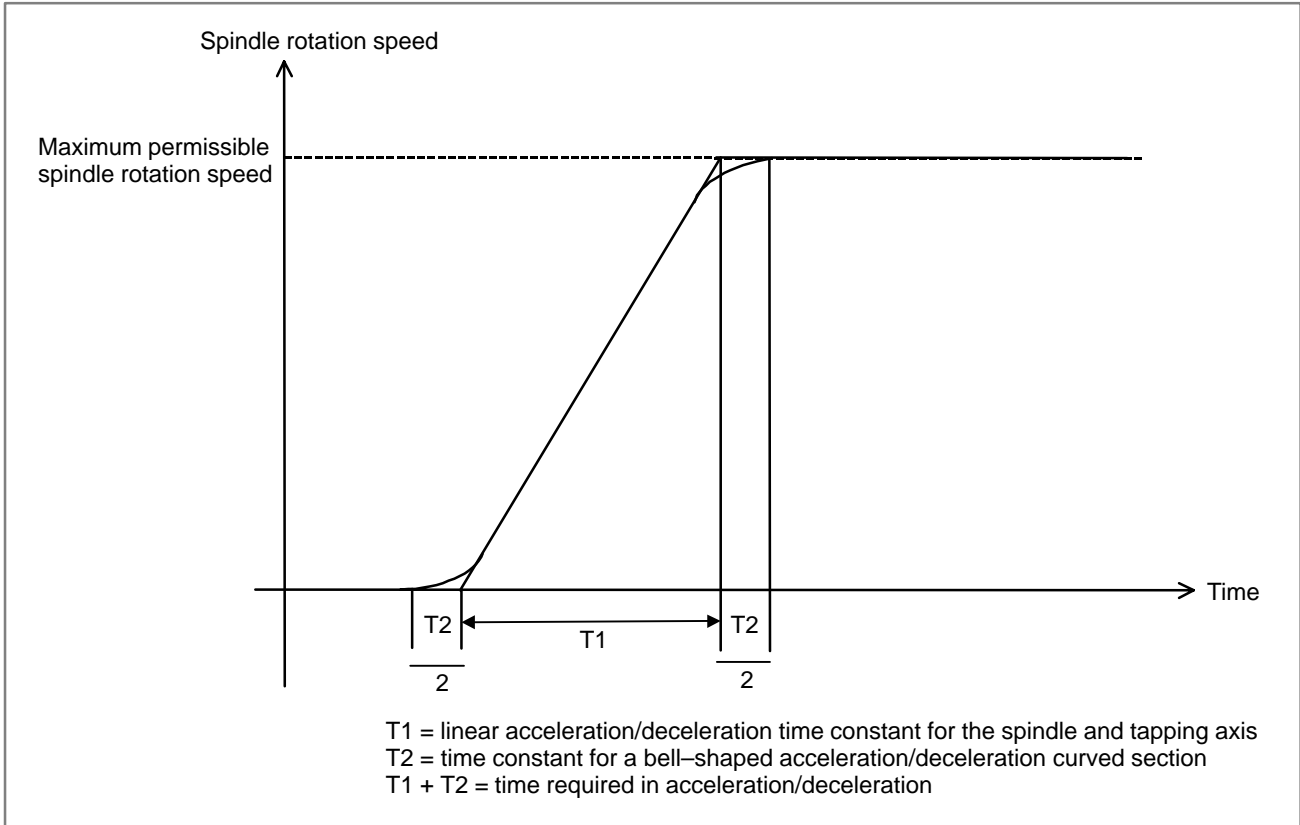

The actual linear acceleration/deceleration time constant, T1, for the spindle and tapping axis is determined according to the ratio of the maximum permissible spindle rotation speed to the actually specified value S. The bell-shaped acceleration/deceleration time constant for the curved section is not proportional to the actual S command. Instead, the bell-shaped acceleration/deceleration is kept constant (value specified in the parameter).

Parameter

	#7	#6	#5	#4	#3	#2	#1	#0
5203			RGBEL					

[Data type] Bit

RGBEL Specifies the type of acceleration/deceleration to be applied to rigid tapping feed, as follows:

- 0 : Bell-shaped acceleration/deceleration
- 1 : Linear acceleration/deceleration

5261	Time constant for the first spindle and tapping axis (first gear stage)
5262	Time constant for the first spindle and tapping axis (second gear stage)
5263	Time constant for the first spindle and tapping axis (third gear stage)
5265	Time constant for the second spindle and tapping axis (first gear stage)
5266	Time constant for the second spindle and tapping axis (second gear stage)
5267	Time constant for the third spindle and tapping axis (first gear stage)
5268	Time constant for the third spindle and tapping axis (second gear stage)

[Data type] Word

[Unit of data] msec

[Valid data range] 0 to 4000

The spindle and tapping axis time constant for each gear stage is set up for rigid tapping.

The time needed for the spindle to reach its maximum permissible rotation speed is specified. The actual time constant is the ratio of the maximum permissible spindle speed to the S command.

If bell-shaped acceleration/deceleration is enabled, the time constant for the straight section is set up.

5271	Time constant for the first spindle and tapping axis for a pull-out operation (first gear stage)
5272	Time constant for the first spindle and tapping axis for a pull-out operation (second gear stage)
5273	Time constant for the first spindle and tapping axis for a pull-out operation (third gear stage)
5335	Time constant for the second spindle and tapping axis for a pull-out operation (first gear stage)
5336	Time constant for the second spindle and tapping axis for a pull-out operation (second gear stage)
5337	Time constant for the third spindle and tapping axis for a pull-out operation (first gear stage)
5338	Time constant for the third spindle and tapping axis for a pull-out operation (second gear stage)

[Data type] Word

[Unit of data] msec

[Valid data range] 0 to 4000

The spindle and tapping axis time constant for each gear stage is set up for a rigid tapping pull-out operation.

If bell-shaped acceleration/deceleration is valid, the time constant for the straight section is set up.

NOTE

These parameters are valid if the TDR parameter (bit 2 of parameter No. 5201) is 1.

5365	First-spindle bell-shaped acceleration/deceleration time constant for rigid tapping (first gear stage)
5366	First-spindle bell-shaped acceleration/deceleration time constant for rigid tapping (second gear stage)
5367	First-spindle bell-shaped acceleration/deceleration time constant for rigid tapping (third gear stage)
5369	Second-spindle bell-shaped acceleration/deceleration time constant for rigid tapping (first gear stage)
5370	Second-spindle bell-shaped acceleration/deceleration time constant for rigid tapping (second gear stage)
5373	Third-spindle bell-shaped acceleration/deceleration time constant for rigid tapping (first gear stage)
5374	Third-spindle bell-shaped acceleration/deceleration time constant for rigid tapping (second gear stage)

[Data type] Word

[Unit of data] msec

[Valid data range] 0 to 512

The time required in bell-shaped acceleration/deceleration for a curved section is set up for rigid tapping.

If these parameters are set to 0, linear acceleration/deceleration is applied.

NOTE

- 1 These parameters are valid if the RGDBEL parameter (bit 5 of parameter No. 5203) is 1.
- 2 When rigid tapping is performed on the second and third spindles,
 - The settings of parameter Nos. 5365 and 5366 are applied to the second and third spindles as well as the first spindle if the SPR parameter (bit 1 of parameter No. 5204) is 0.
 - The settings of parameter Nos. 5369 and 5370 and the settings of parameter Nos. 5373 and 5374 are applied, respectively, to the second and third spindles if the SPR parameter (bit 1 of parameter No. 5204) is 1.

Caution

- (1) The linear acceleration/deceleration time constant parameter for rigid tapping specifies the time required for the spindle to reach its maximum permissible rotation speed. The actual time constant is obtained by calculating the ratio of the maximum permissible spindle rotation speed to the S command. However, the bell-shaped acceleration/deceleration time constant does not depend on that ratio. Instead, it is specified directly in a parameter.
- (2) If the time constant for a pull-out operation is valid (the TDR parameter (bit 2 of parameter No. 5201) is 1), the bell-shaped acceleration/deceleration time constants specified in parameter Nos. 5365 to 5374 are used.
- (3) Bell-shaped acceleration/deceleration is disabled for three-dimensional rigid tapping.
- (4) If the bell-shaped acceleration/deceleration time constants (parameter Nos. 5365 to 5374) are 0, linear acceleration/deceleration is applied.
- (5) If exponential acceleration/deceleration is selected for rigid tapping, bell-shaped acceleration/deceleration is disabled.
- (6) The rigid tapping bell-shaped acceleration/deceleration option does not support rapid traverse bell-shaped acceleration/deceleration. Applying rapid traverse bell-shaped acceleration/deceleration needs the rapid traverse bell-shaped acceleration/deceleration option.

9.11.12**Reference Item**

Series 16i/18i/160i/180i/ 160is/180is	OPERATOR'S MANUAL (For Machining Center) (B-63534EN)	II.13.2	RIGID TAPPING
	OPERATOR'S MANUAL (For Lathe) (B-63524EN)	II.13.8	RIGID TAPPING
Series 21i/210i/210is	OPERATOR'S MANUAL (For Machining Center) (B-63614EN)	II.13.2	RIGID TAPPING
	OPERATOR'S MANUAL (For Lathe) (B-63604EN)	II.13.7	RIGID TAPPING
Series 20i	OPERATOR'S MANUAL (For Manual Milling Machine) (B-64204EN)	II.13.2	RIGID TAPPING
CONNECTION MANUAL (This manual)	9.3	SPINDLE SPEED CONTROL	
	9.10	MULTI-SPINDLE	
FANUC SERVO AMPLIFIER α series DESCRIPTIONS (B-65162E)	11.4	RIGID TAPPING	
FANUC AC SPINDLE MOTOR α series PARAMETER MANUAL (B-65160E)	2.3	RIGID TAPPING	
FANUC AC SPINDLE MOTOR αi series PARAMETER MANUAL (B-65280EN)	2.3	RIGID TAPPING	

9.12 SPINDLE SYNCHRONOUS CONTROL

General

This function enables the synchronous control of two spindles. It also enables the control of the rotation phase of a spindle, allowing non-standard workpieces as well as rods to be held by either of the two spindles.

Synchronous-spindle configuration

In spindle synchronous control, the spindle to which an S command is issued is called the master spindle. A spindle which ignores any S command that is issued for it, instead rotating synchronously with the master spindle, is called the slave spindle.

The table below shows the synchronous spindle configuration.

	Master spindle	Slave spindle
T series/M series	First serial spindle	Second serial spindle
T series (two-path control)	First serial spindle at tool post 1	First serial spindle at tool post 2
M series (two-path control)	First serial spindle at path 1	Second serial spindle at path 1

Supplementary description

For details of synchronous-spindle connection, see the description of serial spindles.

The following description relates to this CNC.

- Synchronous control of spindle phase is executed when the signal for controlling the spindle phases in synchronization is entered in spindle synchronization control mode (after output of the signal indicating that the synchronous control of spindle speed has been completed). The signal indicating that the synchronous control of spindle phase is completed is output when the difference between the error pulses of the two spindles does not exceed the number of pulses specified in parameter No. 4810 of the NC function.

The positions of spindle phase synchronization can be specified in spindle parameter No. 4034 on each of tool post 1 and tool post 2.

When the two spindles are subject to spindle-phase synchronous-control (until the spindle-phase synchronous-control completion signal, FSPPH <F044#3>, turns to "1"), they are not synchronized with each other.

Do not specify spindle-phase synchronous control while the two spindles are holding a workpiece. Specifying this item causes phase synchronous control to start automatically.
- PMC signal, SYCAL <F044#4> is provided to monitor a synchronization errors between spindles for which spindle synchronization control or synchronous control of spindle phase is in effect. The synchronization error between the two spindles is always monitored. The SYCAL signal is set to 1 when the error (the absolute value of the error pulse) specified in parameter No. 4811 of tool post 1 is exceeded, and set to 0 when not exceeded.

- Constant surface speed control can be executed in synchronization control even while a workpiece is being held with the two spindles. However, if the speed is to change in excess of the specified time constant, the speed changes within the extent specified by time constant.
- The maximum speed in synchronization control is determined by the maximum speed of the spindle motor of master spindle (parameter No. 4020).

(Example) Maximum speed of the spindle motor of tool post 1: 6000 min⁻¹
 Maximum speed of the spindle motor of tool post 2: 4500 min⁻¹

In the example above, a maximum spindle speed of 6,000 min⁻¹ is specified for a spindle of tool post 1, although a spindle-speed command can specify up to 12 bits, 4096. If 6,000 min⁻¹ is specified while synchronous control is specified, an overspeed alarm is issued for a spindle of tool post 2. Therefore, do not specify a value of more than 4,500 min⁻¹ in this case.

- Like the conventional spindle speed (S) command for which 4 or 5 digits are issued for the first spindle, the signal for specifying spindle speed can be generated when spindle synchronization control or synchronous control of spindle phase are in the process of being put into effect. The SIND, SSIN SSGN, R011 to R121, *SSTP, and SOR signals are effective as usual.

However, in the usual mode of spindle rotation control, spindle speed can be controlled by the PMC function when the following conditions are satisfied: The SIND signal is set to 1 and the SSIN, SSGN, and R011 to R121 signals are provided. When spindle synchronization control is in the process of being put into effect, something other than the R011 to R121 signals is required to control the spindle speed in synchronization. The maximum spindle gear speed must be properly set in parameters No. 3741, 3742, 3743 and 3744. When the value set in the parameter corresponding to the selected gear is 0, the rotations of the spindles are not synchronized even if a command is entered in the R011 to R121 signals.

- The S command for the master spindle and the PMC control signal for spindle control become effective when issued before spindle synchronization control or synchronous control of spindle phase are put into effect. The S command issued in synchronization control becomes effective for the first spindle immediately after synchronization control is canceled.
- The load may change due to cutting (or threading). When the load changes in spindle synchronization control, the spindle speed may change and the signal indicating that the synchronous control of spindle speed is completed may go off temporarily.
- Parameters No. 4800 #0 (for the master spindle) and #1 (for the slave spindle) are used to set the direction of rotation of the first spindle and second spindle, respectively.
- The gear ratio of the spindle to the position coder must be set to one-to-one.

- In spindle synchronization control, the compensation value for spindle speed offset (parameter No. 3731) is disabled.
- A spindle-phase synchronous control command is effective only in synchronous spindle control mode. The specified phase can be repeatedly changed under synchronous control.

Signal

See the manual of serial spindles.

Parameter

	#7	#6	#5	#4	#3	#2	#1	#0
4800							ND2	ND1

[Data type] Bit type

ND1 In controlling the spindle synchronization, the direction of the first spindle (master spindle) motor rotation is:

0 : The direction indicated by the command sign

1 : The opposite direction to that indicated by the command sign

ND2 In controlling the spindle synchronization, the direction of the 2nd spindle (slave spindle) motor rotation is:

0 : The direction indicated by the command sign

1 : The opposite direction to that indicated by the command sign

4810	Error pulse between two spindles when synchronizing phases in the serial spindle synchronization control mode
------	---

[Data type] Byte type**[Unit of data]** Pulse**[Valid data range]** 0 to 255

Set the difference in error pulses between two spindles when synchronizing phases in the serial spindle synchronization control mode.

When the difference in error pulse between two spindles is within the value set in this parameter, the spindle phase synchronization completion signal FSPPH <F044#3> becomes "1".

This parameter is used to check the difference in phase in synchronization control and to confirm the completion of synchronization in the serial spindle synchronization control mode.

4811	Allowable error count for the error pulses between two spindles in the serial spindle synchronization control mode
------	--

[Data type] Word type**[Unit of data]** Pulse**[Valid data range]** 0 to 32767

Set the allowable error count for the error pulses between two spindles in the serial spindle synchronization control mode.

This parameter is used to output the inter-spindle phase error detection signal SYCAL in the serial spindle synchronization control mode. The SYCAL <F044#4> signal becomes “1” when a phase error exceeding the value set in this parameter is found.

Alarm and message

Number	Message	Description
194	SPINDLE COMMAND IN SYNCHRO-MODE	A contour control mode, spindle positioning (Cs-axis control) mode, or rigid tapping mode was specified during the serial spindle synchronous control mode. Correct the program so that the serial spindle synchronous control mode is released in advance.

Note

NOTE

Signal SYCAL <F044#4> is used for monitoring a phase shift in synchronous control. The processing performed when a phase shift is detected depends on the specifications determined by the machine tool builder.

Reference item

FANUC SERVO AMPLIFIER α series DESCRIPTIONS (B-65162E)	11.7	Spindle synchronization control
FANUC AC SPINDLE MOTOR α series PARAMETER MANUAL (B-65160E)	2.5	Spindle synchronization control
FANUC AC SPINDLE MOTOR αi series PARAMETER MANUAL (B-65280EN)	2.5	Spindle synchronization control

9.13 SPINDLE ORIENTATION

General

This function stops the spindle at a specified position. The spindle can be stopped in either of the following two ways.

- The spindle is stopped using mechanical stop.
- The spindle is stopped by applying a function of the spindle control unit.

Mechanical stop

To mechanically stop the spindle by using, for example, a shot pin, rotate the spindle at a constant low speed and drive the pin into the spindle. The spindle can be rotated at a low constant speed by applying either of the following methods.

- Spindle orientation signal (See 9.3, “Spindle Control.”)
- Spindle output control by the PMC (See 15.4.)

Using the spindle control unit

Some spindle control units can position the spindle motor by using sensors and position coders. The CNC itself does not control positioning by using these units.

Serial spindle orientation by a position coder

In serial spindle orientation by a position coder, the stop position is specified either by a parameter or by the PMC (spindle orientation function with the stop position externally set).

Signal

Spindle orientation signals with the stop position externally set

**SHA00 to SHA11 for the first spindle
<G078, G079>**

**SHB00 to SHB11 for the second spindle
<G080, G081>**

**SHC00 to SHC11 for the third spindle
<G208, G209>**

**SHD00 to SHD11 for the fourth spindle
<G270, G271>**

[Classification] Input signal

[Function] This command is used for specifying a stop position with an absolute position within one rotation in the following equation:

$$= \frac{360}{4096} \times \sum_{i=0}^n (2^i \times P_i)$$

where

$P_i = 0$ when $SHAi = 0$

$P_i = 1$ when $SHAi = 1$

Signal address

	#7	#6	#5	#4	#3	#2	#1	#0
G078	SHA07	SHA06	SHA05	SHA04	SHA03	SHA02	SHA01	SHA00
G079					SHA11	SHA10	SHA09	SHA08
G080	SHB07	SHB06	SHB05	SHB04	SHB03	SHB02	SHB01	SHB00
G081					SHB11	SHB10	SHB09	SHB08
G208	SHC07	SHC06	SHC05	SHC04	SHC03	SHC02	SHC01	SHC00
G209					SHC11	SHC10	SHC09	SHC08
G270	SHD07	SHD06	SHD05	SHD04	SHD03	SHD02	SHD01	SHD00
G209					SHD11	SHD10	SHD09	SHD08

Parameter

	#7	#6	#5	#4	#3	#2	#1	#0
3702					OR2	OR1		OR3

[Data type] Bit

OR1 Whether the stop-position external-setting type orientation function is used by the first spindle motor

0 : Not used

1 : Used

OR2 Whether the stop-position external-setting type orientation function is used by the second spindle motor

0 : Not used

1 : Used

OR3 Whether the stop-position external-setting type orientation function is used by the third spindle motor

0 : Not used

1 : Used

	#7	#6	#5	#4	#3	#2	#1	#0
3704						OR4		

[Data type] Bit

OR4 Whether the stop-position external-setting type orientation function is used by the fourth spindle motor

0 : Not used

1 : Used

Caution**CAUTION**

- 1 To perform spindle orientation by using the spindle control unit, the signals of the spindle control unit must be used. To perform serial spindle orientation by using a position coder (to perform serial spindle orientation with the stop position set externally), the serial spindle control unit signals must be used.
- 2 When the spindle orientation function of stop position external setting type is used, the stop position parameters in spindle orientation with a position coder (No. 4031 and 4204) are invalid.

Note**NOTE**

Spindle orientation with the spindle positioning function differs from that described in this section. For details, see Section 9.8, "Spindle Positioning."

Reference item

FANUC SERVO AMPLIFIER α series DESCRIPTIONS (B-65162E)	11.1 11.2	Position coder method spindle orientation Magnetic sensor method spindle orientation
FANUC AC SPINDLE MOTOR α series PARAMETER MANUAL (B-65160E)	2.1 2.2	Position coder method spindle orientation Magnetic sensor method spindle orientation
FANUC AC SPINDLE MOTOR αi series PARAMETER MANUAL (B-65280EN)	2.1 2.2	Position coder method spindle orientation Magnetic sensor method spindle orientation

9.14 SPINDLE OUTPUT SWITCHING

General

Spindle output switching switches between the two motor windings, one for low speed and the other for high speed, incorporated into the special spindle motors. This ensures that the spindle motor demonstrates stable output characteristics over a wide range.

Since spindle output switching is a function of the spindle control unit, also refer to the manual for the spindle control unit being used.

This section describes the relationship between spindle output switching and the spindle control function in the CNC.

Operation of output-switchable spindle motor

To switch the spindle output characteristics, the windings are usually switched using a relay. Prior to the completion of winding switching, the spindle rotates free from drive power.

Output switching changes the relationship between a speed command, issued from the CNC to the spindle, and the output characteristics of the spindle motor. However, the relationship between the speed command and spindle motor speed is not changed.

Output switching timing

During actual machining, the spindle is usually controlled in the following way.

- (1) Constant spindle speed during cutting, such as milling
- (2) Continuously changing spindle speed during cutting, such as in constant surface speed control
- (3) Controlling the position loop including the spindle motor during rigid tapping, spindle positioning, Cs contour control, etc.

For applications such as those in (1), we recommend switching the output characteristics for low speed and high speed by using the spindle motor speed detection signal of the spindle control unit.

For applications such as those described in (2) and (3), the spindle must not rotate with no drive power applied during cutting or positioning. It is necessary for the output characteristics to be switched appropriately before machining or for output switching to be masked by using a PMC ladder sequence.

Output switching and gear switching

Spindle output switching ensures that the spindle motor demonstrates stable characteristics over a wide range, and eliminates the requirement of a mechanical spindle gear switching mechanism.

In creating a PMC ladder sequence for output switching, however, using the gear switching of the CNC's spindle control function (see 9.3) may facilitate programming.

Note the following points when using gear switching for CNC spindle control for output switching with a machine tool having no mechanical gear switching mechanism.

- When gear selection output signals, GR2O and GR1O <F034 #0, #1>, are used (for machining centers in which constant surface speed control is not provided and GTT, bit 4 of parameter No. 3706, is set to 0)

Set two gears, which are almost the same.

(Example: Value of parameter No. 3741 = value of parameter No. 3742 – 1, value of No. 3742 = Maximum spindle speed)

When parameter No. 3741 is equal to parameter No. 3742, the CNC judges that one gear is used, and does not output the GR2O signal.

- The parameters related to gear switching points, SGT, bit 3 of parameter No. 3705, and SGB, bit 2 of parameter No. 3761, parameter Nos. 3761 and 3751 can be used.
- In usual spindle control, depending on the speed at switching points, the speed specified by the spindle speed command may differ slightly from the actual speed in the area where the maximum spindle speed is set to the maximum speed ± 1 . (This is because the spindle motor speed, specified by the speed command, is calculated based on the settings of parameter Nos. 3741 to 3744.)

This does not apply to rigid tapping. (Because the machine tool is controlled using the feedback signal from the detector in the position loop.)

- When gear selection input signals, GR1 and GR2 <G028 #1, #2>, are used (for lathes or machining centers in which constant surface speed control is provided or GTT, bit 4 of parameter No. 3706, is set to 1) Parameter settings are read according to the input signal information. Unlike the GR2O and GR1O signals, these signals do not require special parameter settings.

Example) When parameter Nos. 3741 and 3742 are set to the maximum spindle speed.

Create a PMC sequence that specifies the following.

For gear 1, set GR1 and GR2 to 0.

For gear 2, set GR2 to 0 and set GR1 to 1.

The PMC must determine the switching timing on the basis of some information.

Reference item

CONNECTION MANUAL (This manual)	9.3 9.11	Spindle control Rigid tapping
FANUC SERVO AMPLIFIER α series DESCRIPTIONS (B-65162E)	11.9	Output switching control
FANUC AC SPINDLE MOTOR α series PARAMETER MANUAL (B-65160E)	2.7	Output switching control
FANUC AC SPINDLE MOTOR αi series PARAMETER MANUAL (B-65280EN)	2.6	Output switching control

9.15 THREE/FOUR- SPINDLE SERIAL OUTPUT

General

The three or four serial spindles can be connected using three/four-spindle serial output.

The third serial spindle operates as an ordinary third analog spindle. For the third as well as the first and second serial spindles, all the functions supported by the serial spindle control unit (spindle orientation, spindle output switching, and spindle switching) can be used.

When the third/fourth spindle orientation function is used, stop-position external-setting type orientation can also be performed for the third or fourth spindle.

This section provides information related to the third/fourth serial spindle added by the three/four-spindle serial output function. The spindle configuration, supported functions, and related signal addresses, parameters, alarms, and diagnosis screens are explained.

For details of the spindle control method and spindle-related functions, refer to the description of each function.

The relationships between the spindle control interfaces and spindle configuration are shown below. (This table relates to a table that appears in Section 9.2.)

Spindle control interface option ○: Provided ×: Not provided			Spindle constructure			
Spindle serial output	Spindle analog output	Three/four-spindle serial output	First spindle	Second spindle	Third spindle	Fourth spindle
○	○	×	First serial spindle The PC can be used.	Second serial spindle The PC can be used(Note 3).	Analog spindle The PC cannot be used.	—
○	×	×	First serial spindle The PC can be used.	Second serial spindle The PC can be used(Note 3).	—	—
×	○	×	Analog spindle The PC can be used.	—	—	—
○	×	○ (Note 2)	First serial spindle The PC can be used.	Second serial spindle The PC can be used(Note 3).	Third serial spindle The PC can be used(Note 3).	Fourth serial spindle The PC cannot be used(Note 3).
×	×	×	Spindle function (S code output) → Controlled by the PMC ladder via an external interface. (CNC is not control serial spindle and analog spindle.)			

NOTE

- 1 PC = Position coder
- 2 The multi-spindle function is required to enable the use of the position coder for the second spindle.
- 3 For an explanation of how to control the speed of the second and third spindles, see Sections 15.4 and 9.10.

(Reference) The serial spindles are connected as follows:

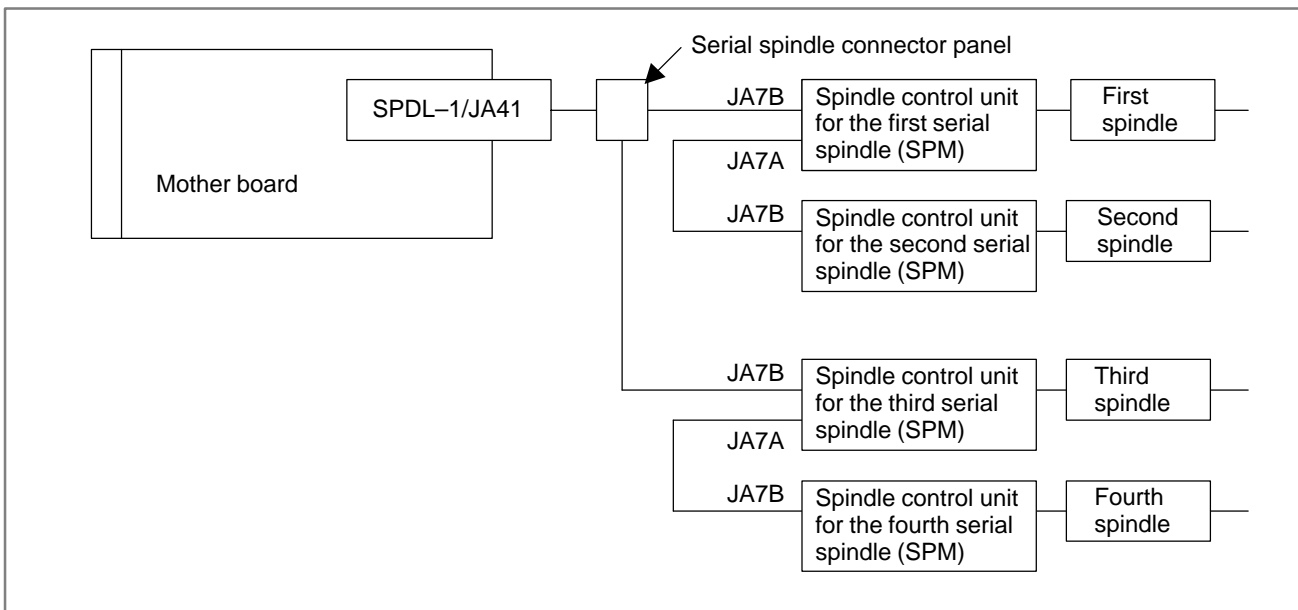

When connecting the serial spindle as the third or fourth spindle, use the serial spindle connector panel.

(Refer to Connection Manual (Hardware) (B-63523EN) for details.)

The table below lists the relationship between the spindles and functions.
(This table relates to a table that appears in Section 9.2.)

○ = Available × = Unavailable

Spindle \ Function		Serial spindle				Analog spindle	
		First spindle	Second spindle	Third spindle (*1)	Fourth spindle	First spindle (*10)	Third spindle (*11)
Thread cutting/feed per rotation (synchronous feed)		○	○ (*4)	○ (*4)	○ (*4)	○	×
Constant surface speed control		○	○ (*4)	○ (*4)	○ (*4)	○	×
Spindle speed fluctuation detection		○	×	×	×	○	×
Actual spindle speed output (T series)		○	○ (*4)	○ (*4)	○ (*4)	○	×
Polygon turning (T series) (using the servo motor axis and spindle)		○	○ (*4)	○ (*4)	○ (*4)	○	×
Polygon turning between spindles (T series) (using two spindles)		○ (*5)	○ (*5)	○ (*5)	○ (*5)	×	×
Spindle positioning (T series)		○	×	×	×	○	×
Cs contour control		○	○	○	○	×	×
Spindle speed control using multi-spindle (*2)		○ : First spindle	○ : Second spindle	○ : Third spindle	○ : Fourth spindle	×	○ : Third axis
Spindle output control using PMC		○	○	○	○	○	○
Rigid tapping		○ (*6)	○ (*6)	○ (*6)	×	○	×
Spindle synchronous control		○ (*7)	○ (*7)	○ (*7)	○ (*7)	×	×
Spindle simple synchronization control		○ (*8)	○ (*8)	○ (*8)	○ (*8)	×	×
Motor speed detection function		○	○	○	×	×	×
Abnormal load detection function		○	○	○	×	×	×
Functions provided by spindle control unit(*3)	Spindle orientation simple	○ (*9)	○ (*9)	○ (*9)	○ (*9)	○	○
	Spindle output switching	○	○	○	○	○	○
	Spindle switching	○	○	○	○	○	○

NOTE

- 1 The multi-spindle function can control the speed of the maximum four spindles and switch the feedback signal between four position coders. It can operate without the second, third, or four spindle (The fourth spindle can be used only when the third spindle configured by a serial spindle is provided.).
- 2 When the multi-spindle function is used with the M series, the constant surface speed control option must be set, or the spindle gear selection method must be set to type T with GTT (bit 4 of parameter No. 3706).
- 3 These functions are provided by the spindle control unit. They cannot be used unless supported by the spindle control unit.
- 4 The multi-spindle function is required. The function cannot be applied to the first to four spindles simultaneously.
- 5 When a two-path lathe is used, spindle polygon turning can be performed using the spindle on tool post 1 and the spindle on tool post 2.
- 6 The first, second, or third spindle can be selected and used for rigid tapping. In this case, the multi-spindle function is required. If the multi-spindle function is not available, rigid tapping can be performed using the first spindle only.
- 7 For a two-path lathe application, the first spindle on tool post 1 is the master, while the first spindle on tool post 2 is the slave. At this time, the second to fourth spindles of either tool post cannot be used in spindle synchronization. For a two-path lathe application, when the second to fourth spindles are used in spindle synchronization (when bit 4 of parameter No. 3704 is set to 1), spindle synchronization cannot be applied to the spindle on tool post 1 and the spindle on tool post 2.
- 8 For a two-path lathe application, spindle simple synchronous control cannot be applied to the spindle on tool post 1 and the spindle on tool post 2.
- 9 The function used to change the spindle orientation stop position (stop-position external-setting type spindle orientation function) can be used by writing G signal addresses from the PMC.
- 10 If the following optional functions are configured, an analog spindle is handled as the first spindle.
 - Spindle serial output : Not provided
 - Third/fourth spindle serial output : Not provided
 - Spindle analog output : Provided
- 11 If the following optional functions are configured, an analog spindle is handled as the third spindle.
 - Spindle serial output : Provided
 - Third/fourth spindle serial output : Not provided
 - Spindle analog output : Provided(The first and second spindles are serial spindles.)

Signal

- **Spindle control unit signals for the third serial spindle <G0204 to G0207> (input), <F0168 to F0171> (output) → for the third serial spindle Spindle control unit signals for the fourth serial spindle <G0266 to G0269> (input), <F0266 to F0269> (output) → for the fourth serial spindle**
- **Spindle orientation stop position external command for the third spindle SHC00 to SHC11 <G0208, G0209> Spindle orientation stop position external command for the fourth spindle SHD00 to SHD11 <G0270, G0271>**
- **Motor speed detection for the third spindle DSP3 <Y(n + 1) #2> (n = setting in parameter No. 1891)**
- **Abnormal load detection for the third spindle ABTSP3 <F0090#3>**

These addresses are on the CNC. Actually, however, they are input/output signals for the serial spindle control unit.

For details of the signals belonging to these addresses, refer to the following manuals:

“FANUC SERVO AMPLIFIER α series Descriptions” (B-65162E)

“FANUC AC SPINDLE MOTOR αi series Parameter Manual” (B-65280EN)

For details, see Section 9.13.

See Section 2.11 for details.

See Section 2.10 for details.

Signal address

- **Spindle control unit signals for the third serial spindle**

	#7	#6	#5	#4	#3	#2	#1	#0
G204	MRDYC	ORCMC	SFRC	SRVC	CTH1C	CTH2C	TLMHC	TLMLC
G205	RCHC	RSLC	INTGC	SOCNC	MCFNC	SPSLC	*ESPC	ARSTC
G206	RCHGHC	MFNHGC	INCMDC	OVRIDC	DEFMDC	NRROC	ROTAC	INDXC
G207				DSCNC	SORSLC	MPOFC	SLVC	MORCMC
	#7	#6	#5	#4	#3	#2	#1	#0
F168	ORARC	TLMC	LDT2C	LDT1C	SARC	SDTC	SSTC	ALMC
F169	MORA2C	MORA1C	PORA2C	SLVSC	RCFNC	RCHPC	CFINC	CHPC
F170				EXOFC	SORENC	MSOVR	INCSTC	PC1DEC
F171								

● Spindle control unit signals for the fourth serial spindle

	#7	#6	#5	#4	#3	#2	#1	#0
G266	MRDYD	ORCMD	SFRD	SRVD	CTH1D	CTH2D	TLMHD	TLMLD
G267	RCHD	RSLD	INTGD	SOCND	MCFND	SPSLD	*ESPD	ARSTD
G268	RCHHGD	MFNHGD	INCMD	OVRIID	DEFMDD	NRROD	ROTAD	INDXD
G269				DSCND	SORSLD	MPOFD	SLVD	MORCMD
	#7	#6	#5	#4	#3	#2	#1	#0
F266	ORARD	TLMD	LDT2D	LDT1D	SARD	SDTD	SSTD	ALMD
F267	MORA2D	MORA1D	PORA2D	SLVSD	RCFND	RCHPD	CFIND	CHPD
F268				EXOFD	SOREND	MSOVRD	INCSTD	PC1DED
F269								

● Spindle orientation stop position external command for the third serial spindle

	#7	#6	#5	#4	#3	#2	#1	#0
G208	SHC07	SHC06	SHC05	SHC04	SHC03	SHC02	SHC01	SHC00
G209					SHC11	SHC10	SHC09	SHC08

● Spindle orientation stop position external command for the fourth serial spindle

	#7	#6	#5	#4	#3	#2	#1	#0
G270	SHD07	SHD06	SHD05	SHD04	SHD03	SHD02	SHD01	SHD00
G271					SHD11	SHD10	SHD09	SHD08

● Motor speed detection for the third serial spindle

	#7	#6	#5	#4	#3	#2	#1	#0
Y (n+1)						DSP3		

NOTE

“n” above is the value set in parameter No. 1891.

● Abnormal load detection for the third serial spindle

	#7	#6	#5	#4	#3	#2	#1	#0
F090					ABTSP3			

Parameter

● Connection of serial spindle control unit

	#7	#6	#5	#4	#3	#2	#1	#0
3701			SS3	SS2			ISI	

NOTE

After setting this parameter, turn the power off then on again so that the setting will take effect.

[Data type] Bit type

- ISI** Specifies whether to use the first and second serial spindle interfaces.
 0 : Use these interfaces.
 1 : Do not use these interfaces.

NOTE

This parameter is valid when the spindle serial output option is provided.
 This bit is used when the CNC is started with serial interface control for the first and second serial spindles temporarily disabled to enable startup adjustment of the CNC.
 This bit should normally be set to 0.
 Similarly, when the serial interface for the third serial spindle is disabled to enable CNC startup adjustment, set SS3, bit 5 of parameter No. 3701, to 0. (ISI cannot disable the serial interface for the third serial spindle.)

- SS2** Specifies whether to use the second serial spindle in serial spindle control.
 0 : Do not use the second serial spindle.
 1 : Use the second serial spindle.

NOTE

This bit is valid when the spindle serial output option is provided, and ISI, bit 1 of parameter No. 3701 is set to 0.

- SS3** Specifies whether to use the third serial spindle in serial spindle control.
 0 : Do not use the third serial spindle.
 1 : Use the third serial spindle.

NOTE

This bit is valid when the spindle serial output and three/fourth-spindle serial output options are provided.

Parameter setting			Serial spindles to be used
SS4 (No.3704#1)	SS3 (No.3701#5)	SS2 (No.3701#4)	
0	0	0	First spindle only
0	0	1	First and second spindles
0	1	0	First and third spindles
0	1	1	First to third spindles
1	1	0	First, third, and fourth spindles
1	1	1	First to fourth spindles

NOTE

- 1 To connect a serial spindle as the third or fourth spindle, the function of three/four-spindle serial output is required.
- 2 The fourth serial spindle can be used just in Series 16i/160i/160is.

	#7	#6	#5	#4	#3	#2	#1	#0
3704							SS4	

NOTE

When this parameter has been set, the power must be turned off before operation is continued.

[Data type] Bit

SS4 Under serial spindle control, the fourth serial spindle is:
 0 : Not used.
 1 : Used.

Bit 5 (SS3) and bit 4 (SS2) of parameter No. 3701 and this parameter specify the number of spindles to be connected.

See the table added to the description of bit 5 (SS3) and bit 4 (SS2) of parameter No. 3701.

NOTE

- 1 To use the fourth serial spindle, the third serial spindle is required.
- 2 The fourth serial spindle can be used just in Series 16i/160i/160is.

- **Parameters of serial spindle control unit**

No. 4000 – 4351: S1 → For 1st serial spindle
 S2 → For 2nd serial spindle
 S3 → For 3rd serial spindle
 S4 → For 4th serial spindle

The above parameters are on the CNC, but actually they are used for the spindle control unit of serial spindle.

For details of these parameters, refer to the following manual:

FANUC AC SPINDLE MOTOR α series Parameter Manual (B-65160E)

FANUC AC SPINDLE MOTOR αi series Parameter Manual (B-65280EN)

● **Stop-position external-setting type spindle orientation**

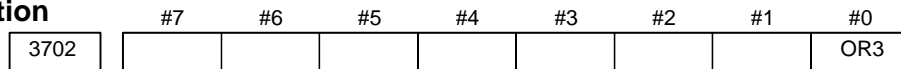
**NOTE**

After setting this parameter, turn the power off then on again so that the setting will take effect.

[Data type] Bit type

OR3 Specifies whether to use the stop-position external-setting type spindle orientation function for the third spindle.

0 : Do not use the function.

1 : Use the function.

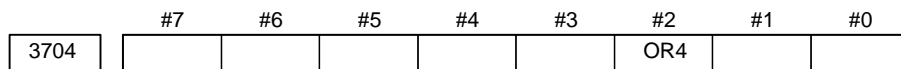
**NOTE**

After setting this parameter, turn the power off then on again so that the setting will take effect.

[Data type] Bit type

OR4 Specifies whether to use the stop-position external-setting type spindle orientation function for the fourth spindle.

0 : Do not use the function.

1 : Use the function.

NOTE

When the stop-position external-setting type spindle orientation function is used, the parameters for setting the spindle orientation stop position using a position coder (parameter Nos. 4031 and 4204) are ignored.

Alarm and message

Number	Message	Contents
749	S-SPINDLE LSI ERROR	<p>It is serial communication error while system is executing after power supply on. Following reasons can be considered.</p> <ol style="list-style-type: none"> 1) Optical cable connection is fault or cable is not connected or cable is cut. 2) MAIN CPU board or option 2 board is fault. 3) Spindle amp. printed board is fault. 4) The spindle amplifier is under an abnormal condition. (The SPM indication is A, A1, A2, or the like, depending on the type of the abnormality.) <p>If this alarm occurs when CNC power supply is turned on or when this alarm can not be cleared even if CNC is reset, turn off the power supply also turn off the power supply in spindle side.</p> <p>If the spindle amplifier is under an abnormal condition, check the SPM indication (A, A1, A2, or the like). Then, refer to the FANUC SERVO MOTOR <i>ai</i> series MAINTENANCE MANUAL (B-65285EN) or FANUC SERVO MOTOR α series MAINTENANCE MANUAL (B-65165E) to solve the problem.</p>
750	SPINDLE SERIAL LINK START FAULT	<p>This alarm is generated when the spindle control unit is not ready for starting correctly when the power is turned on in the system with the serial spindle.</p> <p>The four reasons can be considered as follows:</p> <ol style="list-style-type: none"> 1) An improperly connected optic cable, or the spindle control unit's power is OFF. 2) When the NC power was turned on under alarm conditions other than SU-01 or AL-24 which are shown on the LED display of the spindle control unit. In this case, turn the spindle amplifier power off once and perform startup again. 3) Other reasons (improper combination of hardware) This alarm does not occur after the system including the spindle control unit is activated. 4) The second spindle (when SP2, bit 4 of parameter No. 3701, is 1) is in one of the above conditions 1) to 3). <p>See diagnostic display No. 409 for details.</p>
752	FIRST SPINDLE MODE CHANGE FAULT	<p>This alarm is generated if the system does not properly terminate a mode change. The modes include the Cs contouring, spindle positioning, rigid tapping, and spindle control modes. The alarm is activated if the spindle control unit does not respond correctly to the mode change command issued by the NC.</p>
754	SPINDLE-1 ABNORMAL TORQUE ALM	Abnormal first spindle motor load has been detected.
762	SECOND SPINDLE MODE CHANGE FAULT	Refer to alarm No. 752.(For 2nd axis)
764	SPINDLE-2 ABNORMAL TORQUE ALM	Same as alarm No. 754 (for the second spindle)
772	SPINDLE-3 MODE CHANGE ERROR	Same as alarm No. 752 (for the third spindle)
774	SPINDLE-3 ABNORMAL TORQUE ALM	Same as alarm No. 754 (for the third spindle)

Number	Message	Contents
782	SPINDLE-4 MODE CHANGE ERROR	Same as alarm number 752 (for the fourth spindle)
784	SPINDLE-4 ABNORMAL TORQUE ALM	Same as alarm number 754 (for the fourth spindle)

Diagnosis screen

- Information relating to third/fourth serial spindle control

	#7	#6	#5	#4	#3	#2	#1	#0
430				SS4	SS3	SSR		SIC

SIC 0 : The module required for the three/fourth-spindle serial output function is not installed.

1 : The module required for the three/fourth-spindle serial output function is installed.

SSR 0 : The options required for the three/fourth-spindle serial output function are not installed.

1 : The options required for the three/fourth-spindle serial output function are installed.

SS3 0 : The third serial spindle is not used in the three/fourth-spindle serial output function.

1 : The third serial spindle is used in the three/fourth-spindle serial output function.

SS4 0 : The fourth serial spindle is not used in the three/fourth-spindle serial output function.

1 : The fourth serial spindle is used in the three/fourth-spindle serial output function.

431	Alarm condition for the serial spindle unit for the third spindle (AL-??)
-----	---

432	Alarm condition for the serial spindle unit for the fourth spindle (AL-??)
-----	--

- Communication error for the spindle serial output interface of the third serial spindle

	#7	#6	#5	#4	#3	#2	#1	#0
438	SSA		SCA	CME	CER	SNE	FRE	CRE

CRE 1 : CRC error (warning)

FRE 1 : Framing error (warning)

SNE 1 : Mismatch between sending and receiving sections

CER 1 : Abnormal reception

CME 1 : No answer during auto scanning

SCA 1 : Communication alarm in the spindle amplifier

SSA 1 : System alarm in the spindle amplifier

(The above are errors related to the third/fourth serial spindle. They are reflected in spindle alarm 749. They are usually caused by noise, disconnection, or instantaneous power interruption.

When these statuses appear under diagnosis number 438, check whether there is a problem with the hardware related to the serial spindle connector panel or the cables and spindle amplifier connected to the panel.

● **Information related to the activation of the spindle serial output interface for the third/fourth serial spindle**

	#7	#6	#5	#4	#3	#2	#1	#0
439					SPE	S4E	S3E	SHE

SHE 1 : Abnormal operation in serial spindle communication module on the mother board of the CNC

S3E 1 : Abnormal operation of the third spindle during activation

S4E 1 : Abnormal operation of the fourth spindle during activation

SPE 1 : Serial spindle parameter does not satisfy activation conditions

(The above are errors related to the third serial spindle. They are reflected in spindle alarm 750.)

● **Load and speed meter readings for the third serial spindle**

440	Third serial spindle: Load meter reading (%)
441	Third serial spindle: Speed meter reading (min ⁻¹)
442	Fourth serial spindle: Load meter reading (%)
443	Fourth serial spindle: Speed meter reading (min ⁻¹)

To display the load and speed meter readings, the following parameters must be specified:

Maximum motor speed: Set for each axis in parameter Nos. 4020 (main) and 4196 (sub)

Load meter reading at maximum output: Set for each axis in parameter Nos. 4127 (main) and 4276 (sub)

NOTE

The spindle switch function is used for main/sub switching. Select main spindle when the spindle switch function is not being used.

9.16 SIMPLE SPINDLE SYNCHRONOUS CONTROL

General

In simple spindle synchronous control mode, the second spindle can be controlled as a slave axis of the first spindle.

Therefore, the Cs contour axis control function, rigid tapping function, and spindle positioning function (T series) can be used on a slave axis as long as it is controlled by the first axis.

Note, however, that unlike spindle synchronous control, simple spindle synchronous control does not guarantee synchronization between the first and second spindles. (For details of spindle synchronous control, see Section 9.12.)

To realize simple spindle synchronous control, two serial spindle systems suitable for two-spindle connection are required. Moreover, both spindles must be fitted with spindle-related hardware such as detectors for the functions used with simple spindle synchronous control (Cs contour axis control function, rigid tapping function, and spindle positioning function (T series)).

Simple spindle synchronous control mode is set by applying simple spindle synchronous control signal ESRSYC from the PMC.

During simple spindle synchronous control, the same commands as those that are usually used for the first spindle are used in spindle mode, Cs contour axis control mode, rigid tapping mode, and spindle positioning (T series).

When the parking function is used, one spindle can be stopped in each of the control modes described below. For details, see the description of the parking function.

- **Operation in each control mode**

1. Spindle mode (ordinary spindle control)

The second spindle rotates upon the issue of the same command as that used for the first spindle.

The command does not specify the speed of the spindle, instead specifies the ratio of the spindle motor speed to the maximum speed. So, if the spindle unit configuration (maximum motor speed, motor–spindle gear ratio, and so forth) of the first spindle is the same as that of the second spindle, both spindles will rotate at about the same speed. (The synchronization of rotation cannot be not guaranteed. If the configurations of the two spindles differ, the speed of one spindle will differ from that of the other.) For details of spindle control, see Section 9.3.
2. Cs contour control (contour axis control based on the spindle motor)

When the Cs contour axis control option is selected, contour control can also be applied to the second spindle. Note, however, that independent control is not possible, since the motion of the second spindle is being controlled by the first spindle. The display of the move command address and position data is limited to the first spindle. Reference position return is also performed in the same way as usual. However, both spindles are checked for the completion of reference position return, so that the reference position return signal for the Cs contour control axis is turned on only after reference position return has been completed by both spindles.

While simple spindle synchronous control is applied, the user can switch between spindle mode and Cs contour control mode. For details of Cs contour control, see Section 9.9.
3. Rigid tapping

When the rigid tapping option is selected, the second spindle supports rigid tapping under the control of a rigid tapping command for the first spindle. (Rigid tapping for the second spindle cannot be performed independently of the first spindle.)

During diagnosis, spindle data such as any positional deviation is displayed for the first spindle.

For details of rigid tapping, see Section 9.11.
4. Spindle positioning (T series)

When the spindle positioning option is selected, the spindle positioning function for the second spindle is enabled under the control of a spindle positioning command for the first spindle. (The spindle positioning function for the second spindle cannot be used independently of the first spindle.)

In the same way as with Cs contour axis control, the display of command address and position data is limited to the first spindle. Operations such as orientation are performed in the same way as usual. However, both spindles are checked for the completion of orientation, and the spindle positioning sequence is processed only after the completion of positioning by both spindles has been confirmed.

For details of spindle positioning, see Section 9.8.

- **Parking function**

In simple spindle synchronous control mode, the parking function stops the motion of the first or second spindle, regardless of the mode (spindle mode, spindle positioning mode, Cs contour axis control mode, or rigid tapping mode) of the spindle.

In the parking state, the spindle is placed in the following state, depending on its mode:

In spindle mode: Same state as when S0 is specified

In other modes: Zero distribution state

Spindle orientation in spindle positioning mode and reference position return in Cs contour axis control mode are also disabled for a spindle that has been placed in the parking state.

The parking function stops only spindle motion. So, the parking function can be used to stop only one spindle to enable machining to continue on the other spindle when both spindles are being controlled. The parking function can also be used to place the first spindle in the parking state so that Cs contour axis control, spindle positioning, or rigid tapping can be performed only on the second spindle.

WARNING

When using parking signal PK7 or PK8 for spindle synchronous control (T series) while both simple spindle synchronous control and spindle synchronous control (T series) are being used, set the SPK bit (bit 7 of parameter No. 4800) to 1. This sets parking signals PKESS1 and PKESS2, used for simple spindle synchronous control, to #6 and #7 of G031.

CAUTION

- 1 If the parking function is activated in a mode featuring a position loop, such as Cs contour axis control mode, spindle positioning mode, and rigid tapping mode, the actual machine position of the spindle placed in the parking state will differ from the coordinates recognized by the CNC. This error is caused by parking, so that an excess error alarm is not issued.
- 2 The parking signal becomes active immediately upon simple spindle synchronous control mode being set. However, if the parking signal is applied during reference position return in Cs contour axis control mode or during spindle orientation in spindle positioning mode, reference position return or spindle orientation continues until the completion of the operation; the parking state is set once the reference position has been established.
- 3 While both spindles are placed in the parking state, never specify reference position return in Cs contour axis control mode, or spindle orientation in spindle positioning mode. When both spindles are in the parking state, reference position is not established.

NOTE

- 1 When the parking function is activated for a spindle in a mode featuring a position loop, such as Cs contour axis control mode, spindle positioning mode, and rigid tapping mode, the spindle is stopped at the point where the parking function is activated. If the spindle is shifted from the stop position because of the application of an external force, for example, an excess error alarm is issued. (In simple spindle synchronous control mode, both spindles are checked for any positional error, regardless of whether the parking function is being used.)
- 2 If reference position return is specified in Cs contour axis control mode, or if spindle orientation is specified in spindle positioning mode when one spindle is placed in the parking state, the reference position return completion signal is turned on when the reference position is established for the other spindle.
- 3 Synchronous, composite, and superimposed control cannot be performed for the master or slave axis in simple spindle synchronous control mode.

- **PMC signal control**

Even for simple spindle synchronous control, those functions (including the spindle orientation function) and input/output signals that are to be directly specified for spindle control from the PMC are controlled independently for the first and second spindles.

Specifically, control over the signals in the following areas is exercised independently for the first and second spindles, regardless of whether simple spindle synchronous control mode is enabled.

First spindle: (DGN DI→G0070 to G0073, DO→F0045 to F0048)

Second spindle: (DGN DI→G0074 to G0077, DO→F0049 to F0052)

When using the simple spindle synchronous control function, use the signals for the second spindle (DGN DI→G0074 to G0077, DO→F0049 to F0052) as required in addition to simple spindle synchronous control signal ESRSYC.

Basically, no conventional PMC signal addresses and sequences need to be modified for simple spindle synchronous control, except for the addition of PMC control over the second spindle.

Simple spindle synchronous control can be turned on and off by turning simple spindle synchronous control signal ESRSYC on and off.

NOTE

In simple spindle synchronous control mode, the states of the first and second spindles are checked. So, if simple spindle synchronous control is specified in Cs contour axis control mode before the second spindle is activated, for example, the VRADY OFF alarm may be issued. Careful attention should also be paid to PMC control over the second spindle.

- **Simple spindle synchronization and phase error monitor signal**

Simple spindle synchronous control does not guarantee synchronous spindle operation. However, in a control mode featuring a position loop, such as Cs contour axis control mode, rigid tapping mode, and spindle positioning mode, the synchronization of both spindles can be guaranteed by matching the position gain of one spindle to that of the other.

For this purpose, phase error monitor signal SYCAL is provided to monitor both spindles for phase error. The error between the two spindles is constantly monitored. If an error that exceeds the value set in parameter No. 4811 is detected, the signal is set to 1. If a detected error does not exceed the value set in parameter No. 4811, the signal is set to 0.

In spindle mode, however, this signal SYCAL is ignored, being set to 0 at all times.

Note that even if phase error monitor signal SYCAL is output, no CNC alarm is issued.

This signal is designed to be used by the PMC to monitor the machine synchronization state. Its usage varies depending on the machine tool builder. The use of this signal is not mandatory.

NOTE

During simple spindle synchronous control, synchronization between the first and second spindles is not guaranteed in spindle mode. However, in Cs contour axis control mode, rigid tapping mode, and spindle positioning mode, the synchronization of the spindles can be guaranteed by matching the position gain of one spindle with that of the other.

Note that spindle synchronization cannot be guaranteed if either spindle is undergoing reference position return in Cs contour axis control mode or orientation in spindle positioning mode, or if it is using a function (such as spindle orientation) that is specified directly from the PMC.

● **Relationship between simple spindle synchronous control and spindle synchronous control**

When the spindle synchronous control option is selected, ensure that simple spindle synchronous control signal ESRSYC is active when synchronous control is not exercised.

Also, ensure that spindle synchronous control signal SRSYC is not active during simple spindle synchronous control.

If the spindle synchronous control signal and simple spindle synchronous control signal are active at the same time, the current mode remains set, and the NC issues alarm PS194 as a warning.

This alarm returns the value of the signal (SRSYC or ESRSYC) last set high back to 0, and remains on until reset back to 1.

In a mode other than spindle synchronous control mode, simple spindle synchronous control signal ESRSYC can be issued at any time. However, the response of the second spindle varies according to the first spindle state existing when ESRSYC is applied.

No particular restrictions are imposed on the timing at which the simple spindle synchronous control signal is set to 0. When simple spindle synchronous control signal ESRSYC is set to 0, the second spindle is immediately initialized to spindle mode, regardless of its previous mode. The mode of the first spindle remains as is.

The table below summarizes the changes in the first spindle and second spindle states depending on the transition of simple spindle synchronous control signal ESRSYC and the state of spindle synchronous control signal SRSYC.

Transition of simple spindle synchronous control signal	ESRSYC 0 → 1			ESRSYC 1 → 0		
	State change of first spindle	SP → SP (Remains as is)	CT → CT (Remains as is) (Note 1)	SV → SV (Remains as is) (Note 2)	SP → SP (Remains as is)	CT → CT (Remains as is)
State change of second spindle	SP → SP (Note 3)	SP → CT (Note 1)	SP → SV (Note 2)	SP → SP (Note 4)	CT → SP (Note 4)	SV → SP (Note 4)
When the spindle synchronous control option is selected	SRSYC 1 (during spindle synchronous control) → Alarm No. 194 is issued. SRSYC 0 (not during spindle synchronous control) → The same changes as those indicated above occur.			SRSYC 1 (during spindle synchronous control) → Alarm No. 194 is released by a reset. SRSYC 0 (not during spindle synchronous control) → The same changes as those indicated above occur.		

Legend

SP : Spindle mode CT: Cs contour axis control mode

SV : Rigid tapping mode, or spindle positioning mode (T series only)

NOTE

- 1 The second spindle is initialized to Cs contour axis control mode. At this time, the position of the second spindle will be undefined, so that reference position return must be performed for the first and second spindles. In this case, the reference position return command that is usually used can be applied. (See Section 9.9.)
- 2 While the first spindle is in rigid tapping mode or spindle positioning mode, the input of simple spindle synchronous control signal ERSYC is masked in the NC to prevent the setting of simple spindle synchronous control mode. When the first spindle is initialized to spindle mode or Cs contour axis control mode after the cancellation of rigid tapping mode or Cs contour axis control mode, the second spindle enters simple spindle synchronous control mode, and is initialized together with the first spindle. After simple spindle synchronous control mode has been set, initialization to rigid tapping mode or spindle positioning mode, command specification, and cancellation are performed for both the first and second spindles.
- 3 The mode is not changed. The second spindle, however, is initialized to spindle mode. After being initialized to spindle mode, the second spindle operates according to commands issued for the second spindle, such that the feedrate may change.
- 4 The second spindle is immediately initialized to spindle mode, regardless of its previous mode. The state of the first spindle, however, remains as is.

- **Spindle rotation direction**

In simple spindle synchronous control mode, the same output and move commands are issued to both the first and second spindles.

When one spindle is to rotate in the opposite direction to that of the other spindle, the direction of rotation can be reversed by using a PMC signal (SFR or SRV signal) or serial spindle parameter according to the currently set mode.

- **Error monitoring and alarm display**

When simple spindle synchronous control is exercised in a mode other than spindle mode, feedback information relating to the first and second spindles is monitored for positional deviation. That is, an in-position check is made, and an excess error check is made upon stop and move.

The usually specified parameter is used for both spindles.

Moreover, upon the issue of an alarm to indicate the occurrence of an error, no distinction is made between the first and second spindles, the alarm being issued as a first spindle alarm.

- **Positional deviation display**

During simple spindle synchronous control, indications such as the positional deviation of the first spindle are output in the usual way. For the second spindle, however, only the positional deviation of the second spindle is indicated in diagnostic data No. 415.

The positional deviation of the first spindle is indicated in diagnostic data No. 414.

The absolute phase deviation between the first and second spindles is indicated as a synchronization error in diagnostic data No. 414.

Signal

Simple spindle synchronous control signal ESRSYC<G064#6>

[Classification] Input signal

[Function] This signal specifies switching between simple spindle synchronous control mode and ordinary spindle synchronous control mode when simple spindle synchronous control is active.

[Operation] When this signal is set to 1, the control unit operates as follows:

- Enters simple spindle synchronous control mode.

First spindle parking signal PKESS1<G122#6> <G031#6>

[Classification] Input signal

[Function] This signal activates the parking function for the first spindle when simple spindle synchronous control is active.

[Operation] When this signal is set to 1, the control unit operates as follows:

- Activates the parking function for the first spindle placed under simple spindle synchronous control.

When the SPK bit (bit 7 of parameter No. 4800) is set to 1, #6 of G031 functions as this signal.

Second spindle parking signal PKESS2<G122#7> <G031#7>

[Classification] Input signal

[Function] This signal activates the parking function for the second spindle when simple spindle synchronous control is active.

[Operation] When this signal is set to 1, the control unit operates as follows:

- Activates the parking function for the second spindle placed under simple spindle synchronous control.

When the SPK bit (bit 7 of parameter No. 4800) is set to 1, #7 of G031 functions as this signal.

Phase error monitor signal SYCAL<F044#4>

[Classification] Input signal

[Function] This signal monitors the synchronization error between the two spindles when simple spindle synchronous control is active.

[Operation] This signal is set to 1 in the following case:

- When the synchronization error between the two spindles is equal to or greater than the value set in parameter No. 4811

This signal is set to 0 in the following case:

- When the synchronization error between the two spindles is less than the value set in parameter No. 4811

Phase error monitor signal SYCAL is not a latch signal, instead being switched between 0 and 1 by constantly monitoring whether the position error between the two spindles is within the value set in parameter No. 4811.

In addition to the above signals, the following spindle control unit signals for the serial spindles must be controlled so that the second spindle functions in the same way as the first:

<G0070 to G0073> (input), <F0045 to F0048> → For the first serial spindle

<G0074 to G0077> (input), <F0049 to F0052> → For the second serial spindle

For details of the signals at these addresses, see Section 9.2. Also, refer to the following manuals:

FANUC SERVO AMPLIFIER α series Descriptions (B-65162E)

FANUC SERVO MOTOR α i series Maintenance Manual (B-65280EN)

Signal address

	#7	#6	#5	#4	#3	#2	#1	#0
G031	PKESS2	PKESS1						
G064		ESRSYC						
G122	PKESS2	PKESS1						
	#7	#6	#5	#4	#3	#2	#1	#0
F044				SYCAL				

Parameter

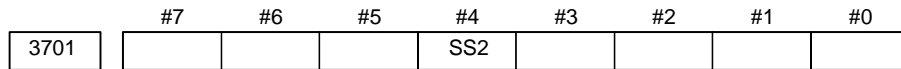

NOTE
 After setting this parameter, turn the power off then on again so that the setting will take effect.

[Data type] Bit

SS2 Under serial spindle control, the second serial spindle is:
 0 : Not used.
 1 : Used.

NOTE

1. This parameter is enabled when the spindle serial output option is selected, and bit 1 (ISI) of parameter No. 3701 is set to 0.
2. If the spindle synchronous control option is selected, this parameter is automatically set at power-on. Once this parameter is set, the following is possible:
 - 1 Confirmation of connection with, and communication with the second serial spindle amplifier
 - 2 Control of the second spindle when asynchronous control is used (SIND2)

Before the simple spindle synchronous control function can be used, two serial spindles must be connected. This means that the user must set this parameter beforehand; it is not set automatically.
 When this parameter is set, the serial spindle parameter for the second spindle must also be set.

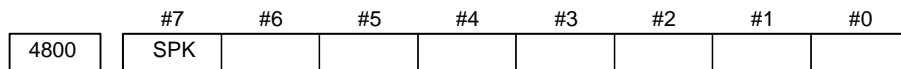

[Data type] Bit

NOTE
 To put this parameter setting in effect, switch the power off then back on again.

SPK Specifies what is to be used as the parking signal for spindle simple synchronization control.
 0 : PKESS1 <G122#6> (first spindle) and PKESS2 <G122#7> (second spindle)
 1 : PKESS1 <G031#6> (first spindle) and PKESS2 <G031#7> (second spindle)

4811

Allowable error count for the error pulses between two spindles in the serial spindle synchronization control mode

[Data type] Word**[Unit of data]** Pulse**[Valid data range]** 0 to 32767

Set the allowable error count for the error pulses between two spindles in the serial spindle synchronization control mode.

NOTE

This parameter is used to output the inter-spindle phase error detection signal SYCAL in the serial spindle synchronization control mode. The SYCAL signal becomes high when a phase error exceeding the value set in this parameter is found.

When specifying this parameter to enable error pulse detection during simple spindle synchronous control, set this parameter as required, noting the mode of the spindle. (In spindle mode, this parameter cannot be used. This parameter can be specified only in Cs contour axis control mode, rigid tapping mode, and spindle positioning mode, but note that the detection unit per pulse differs.)

Alarm and message

Number	Message	Contents
194	SPINDLE COMMAND IN SYNCHRO-MODE	The Cs contour axis control mode, spindle positioning mode, rigid tapping mode, or simple spindle synchronous control is specified in spindle synchronous control mode. Modify the program to cancel spindle synchronous control mode beforehand. Alternatively, spindle synchronous control can be specified in simple spindle synchronous control mode. Modify the program to cancel simple spindle synchronous control mode before specifying spindle synchronous control.

Diagnosis screen

- **Positional deviation display while spindle synchronous control is applied**

414	Master spindle motion error while spindle synchronous control or simple spindle synchronous control is active
415	Slave spindle motion error while spindle synchronous control or simple spindle synchronous control is active
416	Absolute value of synchronization error while spindle synchronous control or simple spindle synchronous control is active

The display units for diagnostic data 414 through 416 are pulses; in spindle synchronous control mode, one pulse corresponds to an error of 360/4096 (degrees).

In simple spindle synchronous control mode, the detection unit per pulse depends on whether Cs contour axis control mode, rigid tapping mode, or spindle positioning mode is set, and also on the type and mounting of the detector.

9.17 READY SIGNALS FOR SERIAL SPINDLE OPERATION

General

The signal indicating the operation ready status of each serial spindle is output.

• ON conditions

When all of the following conditions are satisfied, the relevant signal is set to 1:

- The serial spindle is to be used according to the setting.
- No serial communication alarm (alarm No. 749 or 750) occurs.
- Serial spindle parameters have been transferred.
- The spindle control software is ready to run.
(Appropriate serial spindle parameters are set.)

• OFF conditions

When one of the following conditions is satisfied, the relevant signal is set to 0:

- The serial spindle is not to be used according to the setting.
- Serial spindle parameters have not been transferred.
(Transfer from the CNC to the SPD or from the SPD to the CNC according to automatic setting [bit 7 of parameter No. 4019 is set to 1])
- The spindle control software is not ready to run.
(The spindle control software does not start if the setting of a serial spindle parameter transferred from the CNC to the SPD is inappropriate.)
- A serial communication alarm (alarm No. 749 or 750) occurs.

Signal

Operation ready signal for all serial spindles to be used

SRSRDY 0 : One of serial spindles to be used according to the setting is not ready.
1 : All serial spindles to be used according to the setting are ready.

Ready signal for the first serial spindle operation

SRSP1R Indicates the ready status of the first serial spindle operation when the spindle is to be used according to the setting.
0 : The spindle is not ready.
1 : The spindle is ready.

Ready signal for the second serial spindle operation

SRSP2R Indicates the ready status of the second serial spindle operation when the spindle is to be used according to the setting.
 0 : The spindle is not ready.
 1 : The spindle is ready.

Ready signal for the third serial spindle operation

SRSP3R Indicates the ready status of the third serial spindle operation when the spindle is to be used according to the setting.
 0 : The spindle is not ready.
 1 : The spindle is ready.

Ready signal for the fourth serial spindle operation

SRSP4R Indicates the ready status of the fourth serial spindle operation when the spindle is to be used according to the setting.
 0 : The spindle is not ready.
 1 : The spindle is ready.

Signal address

	#7	#6	#5	#4	#3	#2	#1	#0
F0034	SRSRDY	SRSP1R	SRSP2R	SRSP3R	SRSP4R			

NOTE

- These signals are used to check whether the serial spindle control software has started and do not indicate that spindle control can actually be applied to the corresponding spindles.
 (Example: These signals may be set to 1 also when the spindle control units are in the emergency stop state.)
 After these signals are set to 1, the commands, parameter settings, and signals become valid for the corresponding serial spindle control units. To actually use each function of the spindle control units, the required parameters must be set and the required signals must be input.
- When the two-path control option is also used, the result of monitoring the serial spindles connected to the local path is output for each path.
 (SRSRDY_{#1} <F0034#7>, SRSRDY_{#2} <F1034#7>)
 When the two-path control option is also used, to check the operation ready status of all serial spindles, take action such as ANDing SRSRDY_{#1} <F0034#7> and SRSRDY_{#2} <F1034#7> on the PMC.

10

TOOL FUNCTIONS



10.1 TOOL FUNCTION

General

- **M series**

Selection of tools can be done by commanding tool numbers with up to an 8-digit numeral after address T.

- **T series**

Selection of tools and offset amounts can be done by commanding tool numbers and offset numbers with up to an 8-digit numeral after address T. The offset number is specified with the last one or two digits of the T code. The tool number is specified with the remaining digits after excluding the one or two digits used to specify the offset number.

When the last one digit is used to specify the offset number:
(Parameter LD1 (No. 5002#0)=1)

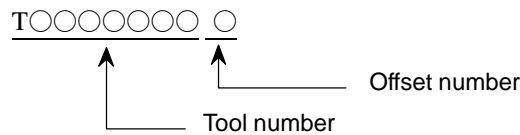

When the last two digits are used to specify the offset number:
(Parameter LD1 (No. 5002#0)=0)

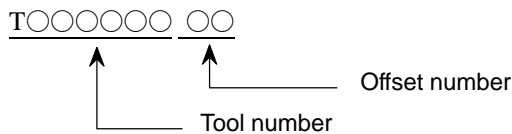

When a T code is specified, the code signal and strobe signal corresponding to the specified tool number are issued. The machine selects a tool according to the issued signals. The code signal is held until another T code is specified.

In a block, no more than one T code can be specified. The maximum number of digits that can follow T can be specified in parameter 3032. If this number is exceeded, an alarm occurs.

Signal

See Section 8.1.

Parameter

3032	Allowable number of digits for the T code
------	---

[Data type] Byte

[Valid data range] 1 to 8

Set the allowable numbers of digits for the T code.

5002	#7	#6	#5	#4	#3	#2	#1	#0
							LGN	LD1

[Data type] Bit

LD1 Offset number of tool offset (Wear offset number when option of tool geometry/wear compensation is selected)

0 : Specified using the lower two digits of a T code

1 : Specified using the lower one digit of a T code

LGN Geometry offset number of tool offset (When the option of tool geometry/wear compensation is selected, it is effective.)

0 : Is the same as wear offset number

1 : Specifies the geometry offset number by the tool selection number

5006	#7	#6	#5	#4	#3	#2	#1	#0
							TGC	

[Data type] Bit

TGC When a T code is specified in a block containing G50, G04, or G10:

0 : No alarm occurs.

1 : P/S alarm No. 254 occurs.

Alarm and message

Number	Message	Description
030	ILLEGAL OFFSET NUMBER (T series)	The offset number in T function specified for tool offset is too large. Modify the program.
043	ILLEGAL T-CODE COMMAND (M series)	In a system using the DRILL-MATE with an ATC, a T code was not specified together with the M06 code in a block. Alternatively, the T code was out of range.
245	T-CODE NOT ALLOWED IN THIS BLOCK (T series)	One of the G codes, G50, G10, and G04, which cannot be specified in the same block as a T code, was specified with a T code.

Note**NOTE**

When a move command and a tool function are specified in the same block, the commands are executed in one of the following two ways:

- (i) Simultaneous execution of the move command and tool function commands.
- (ii) Executing tool function commands upon completion of move command execution.

The selection of either (i) or (ii) depends on the sequence program of PMC.

Reference item

Series 16 <i>i</i> /18 <i>i</i> /160 <i>i</i> /180 <i>i</i> / 160 <i>s</i> /180 <i>s</i>	OPERATOR'S MANUAL (For Machining Center) (B-63534EN)	II.10.1	TOOL SELECTION FUNCTION
	OPERATOR'S MANUAL (For Lathe) (B-63524EN)	II.10.1	TOOL SELECTION FUNCTION
Series 21 <i>i</i> /210 <i>i</i> /210 <i>s</i>	OPERATOR'S MANUAL (For Machining Center) (B-63614EN)	II.10.1	TOOL SELECTION FUNCTION
	OPERATOR'S MANUAL (For Lathe) (B-63604EN)	II.10.1	TOOL SELECTION FUNCTION
Series 20 <i>i</i>	OPERATOR'S MANUAL (For Manual Milling Machine) (B-64204EN)	II.10.1	TOOL SELECTION FUNCTION
	OPERATOR'S MANUAL (For Manual Lathes) (B-64194EN)	II.10.1	TOOL SELECTION FUNCTION
CONNECTION MANUAL (This manual)		8	AUXILIARY FUNCTION

10.2 TOOL COMPENSATION VALUE/ TOOL COMPENSATION NUMBER/ TOOL COMPENSATION MEMORY

10.2.1 Tool Compensation Value/Tool Compensation Number/Tool Compensation Memory

General (M series)

Tool compensation values include tool geometry compensation values and tool wear compensation values (Fig. 10.2.1 (a)). The geometry compensation and wear compensation can be combined into to the tool compensation.

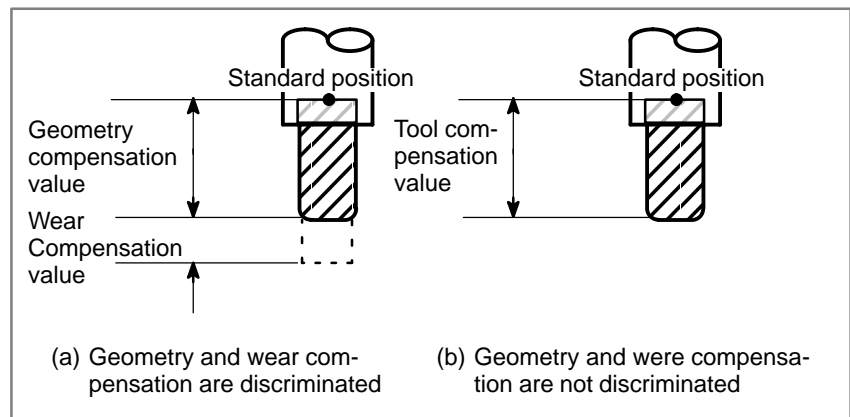

Fig. 10.2.1(a) Geometric compensation and wear compensation

Tool compensation values can be entered into CNC memory from the MDI or from a program.

A tool compensation value is selected from the CNC memory when the corresponding code is specified after address H or D in a program.

The value is used for tool length compensation, cutter compensation, or the tool offset.

- **Range of tool compensation value**

Tool offset amount range which can be set is as follows:

Increment system	Tool compensation (Geometry compensation)		Tool wear compensation	
	Metric input	Inch input	Metric input	Inch input
IS-B	± 999.999mm	± 99.9999inch	± 99.999mm	± 9.9999 inch
IS-C	± 999.9999mm	± 99.99999inch	± 99.9999mm	± 9.99999inch

- **Tool compensation number**

The memory can hold 32, 64, 99, 200, 400, 499 or 999 sets of tool compensation values.

● **Tool compensation memory**

One of the tool compensation memory A/B/C can be selected according to the configuration of offset amount.

(1) Tool compensation memory A

There is no difference between geometry compensation memory and wear compensation memory in tool compensation memory A. Therefore, amount of geometry offset and wear offset together is set as the offset memory. There is also no differences between cutter compensation (D code) and tool length compensation (H code).

(2) Tool compensation memory B

Memory for geometry compensation and wear compensation is separate in tool compensation memory B. Geometry compensation and wear compensation can thus be set separately. There is no difference between cutter compensation (D code) and tool length compensation (H code).

(3) Tool compensation memory C

Memory for geometry compensation and wear compensation is separate in tool compensation memory C. Geometry compensation and wear compensation can thus be set separately. Separate memories are prepared for cutter compensation (for D code) and for tool length compensation (for H code).

The above description is summarized as follows:

Tool compensation memory	Compensation amount
A	Tool compensation amount (Geometry compensation value + Wear compensation value)
B	Geometry compensation value
	Wear compensation value
C	Geometry compensation value for H code
	Geometry compensation value for D code
	Wear compensation value for H code
	Wear compensation value for D code

General (T series)

Tool compensation values include tool geometry compensation values and tool wear compensation values (Fig. 10.2.1 (b)).

There are two geometric compensation types. One type is the so-called "geometric compensation," and the other type is the second tool geometry compensation, for which the PMC can specify a command direction and whether to use it.

Tool compensation can be specified without differentiating compensation for tool geometry from that for tool wear (Fig. 10.2.1 (c)).

NOTE

- 1 Using the second figure tool offset requires the tool figure/wear compensation option. It also requires that the LD1 parameter (bit 0 of parameter No. 5002) and LGN parameter (bit 1 of parameter No. 5002) be, respectively, reset to 0 and set to 1.
- 2 When the second figure tool offset is used, the compensation amount to be applied is obtained by: Figure compensation amount ((second figure compensation amount) + wear compensation amount

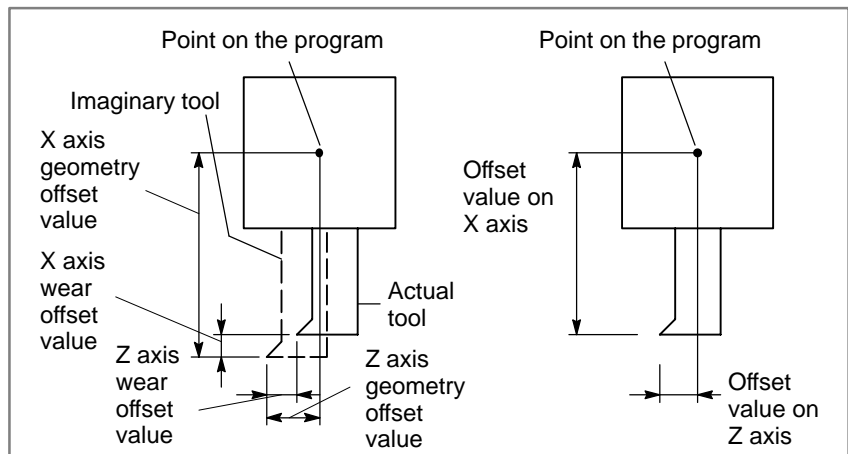

Fig. 10.2.1 (b) Difference the tool geometry offset from tool wear offset

Fig.10.2.1 (c) Not difference the tool geometry offset from tool wear offset

Tool compensation values can be entered into CNC memory from the MDI unit or from a program.

A tool compensation value is selected from the CNC memory when the corresponding code is specified after address T in a program.

The value is used for tool offset or tool nose radius compensation.

● **Range of tool compensation value**

Tool offset amount range which can be set is as follows:

Increment system	Tool compensation (geometry compensation, wear compensation)	
	Metric input	Inch input
IS-B	± 999.999 mm	± 99.9999 inch
IS-C	± 999.9999 mm	± 99.99999 inch

Range of tool compensation value can be expanded by option.

Increment system	Tool compensation value (geometry compensation, wear compensation)	
	Metric input	Inch input
IS-B	±9999.999 mm	±999.9999 inch
IS-C	±9999.9999 mm (±4000.0000 mm)	±999.99999 inch (±160.00000 inch)

NOTE

- 1 When parameter OIM (No. 5006#0)=1, the range in parenthesis is available.
- 2 The above table does not apply to the B-axis offset in B-axis control function.

- **Tool compensation number**
- **Tool compensation memory**

The memory can hold 16, 32, 64, 99, 400, or 999 sets of tool compensation values.

There are two types of tool offset amount memory, which can be selected according to the configuration of offset amount.

- Tool geometry/wear compensation option not specified
There is no difference between geometry offset memory and wear offset memory. Therefore, amount of geometry offset and wear offset together is set as the offset memory.
- Tool geometry/wear compensation option specified
Memory for geometry compensation and wear compensation is prepared separately. Geometry compensation and wear compensation can thus be set separately.

If the second figure tool offset option is available, the second figure compensation amount can also be set.

The above description is summarized as follows:

Tool compensation memory	Compensation amount
Without geometry/wear compensation	Tool compensation amount (Geometry compensation value + Wear compensation value)
With geometry/wear compensation	Geometry compensation (, Second secmetry compensation)
	Wear compensation

- **Disabling soft key [ERASE] on the offset screen**

A parameter can be set to turn off the display of soft key [ERASE] on the offset screen and disable the soft key's function to erase an offset.

Signal

**Second figure tool offset signal
G2SLC <G090#7>**

[Classification] Input signal

[Function] Selects whether to enable the second figure tool offset.

[Operation] When a tool number is specified using a T code, only the first figure tool offset value is valid if this signal is 0. If the signal is 1, the sum of the first figure tool offset value and the second figure tool offset value is used.

Second figure tool offset axis select signal

**G2Y <G090#6>, G2Z
<G090#5>, G2X
<G090#4>**

[Classification] Input signal

[Function] Selects an axis for which the sum of the first figure tool offset value and the second figure tool offset value is applied.

[Operation] If the signal is 0, the second figure tool offset value is not added for the controlled axis corresponding to the axis bit. If the signal is 1, the second figure tool offset value is added for the controlled axis corresponding to the axis bit. This signal is valid when the G2SLC (the second figure tool offset) signal is 1.

NOTE

G2Y requires the Y-axis offset option.

Tool offset direction signal

**G2RVY <G090#2>,
G2RVZ <G090#1>,
G2RVX <G090#0>**

[Classification] Input signal

[Function] Changes the direction of a compensation amount when the tool offset is used.

[Operation] When an axis-specific tool offset value (wear tool offset value + figure tool offset value) is applied, that value is used without being modified if the signal is 0. If the signal is 1, the tool offset is applied in a reverse direction.

NOTE

G2RVY requires the Y-axis offset option.

Signal address

	#7	#6	#5	#4	#3	#2	#1	#0
G090	G2SLC	G2Y	G2Z	G2X		G2RVY	G2RVZ	G2RVX

Parameter

	#7	#6	#5	#4	#3	#2	#1	#0
3109							DWT	

[Data type] Bit

DWT Characters G and W in the display of tool wear/geometry compensation amount

- 0 : The characters are displayed at the left of each number.
- 1 : The characters are not displayed.

	#7	#6	#5	#4	#3	#2	#1	#0
3205				OSC				

[Data type] Bit

OSC On the offset screen, offset value erasure by a soft key is:

- 0 : Enabled.
- 1 : Disabled.

	#7	#6	#5	#4	#3	#2	#1	#0
3290			GO2				GOF	WOF

[Data type] Bit

WOF Setting the tool wear compensation value by MDI key input is:

- 0 : Not disabled
- 1 : Disabled (With parameter No. 3294 and No. 3295, set the offset number range in which updating the setting is to be disabled.)

GOF Setting the tool geometry compensation value by MDI key input is:

- 0 : Not disabled
- 1 : Disabled (With parameter No. 3294 and No. 3295, set the offset number range in which updating the setting is to be disabled.)

GO2 Specifies whether to disable MDI key input operations from being used to set the second tool figure compensation amount, as follows:

- 0 : To disable.
- 1 : Not to disable.

3294	Start number of tool offset values whose input by MDI is disabled
------	---

3295	Number of tool offset values (from the start number) whose input by MDI is disabled
------	---

[Data type] Word

When the modification of tool offset values by MDI key input is to be disabled using bit 0 (WOF) of parameter No. 3290 and bit 1 (GOF) of parameter No. 3290, parameter Nos. 3294 and 3295 are used to set the range where such modification is disabled. In parameter No. 3294, set the offset number of the start of tool offset values whose modification is disabled. In parameter No. 3295, set the number of such values.

Example:

The following setting disables the modification of both the tool geometry compensation values and tool wear compensation values corresponding to offset numbers 100 to 110:

Bit 1 (GOF) of parameter No. 3290 = 1 (Disables tool geometry compensation value modification.)

Bit 0 (WOF) of parameter No. 3290 = 1 (Disables tool wear compensation value modification.)

Parameter No. 3294 = 100

Parameter No. 3295 = 11

If bit 0 (WOF) of parameter No. 3290 is set to 0, the modification of the tool geometry compensation values alone is disabled. The tool wear compensation values may be modified.

	#7	#6	#5	#4	#3	#2	#1	#0
5002	WNP						LGN	

[Data type] Bit

LGN Geometry offset number of tool offset (When the option of tool geometry/wear compensation is selected, it is effective.)

0 : Is the same as wear offset number

1 : Specifies the geometry offset number by the tool selection number

WNP Imaginary tool tip direction used for tool nose radius compensation, when the geometry/wear compensation option is selected, is the direction specified by:

0 : Geometry offset number

1 : Wear offset number

	#7	#6	#5	#4	#3	#2	#1	#0
5004							ORC	

[Data type] Bit

ORC Tool offset value

0 : Set by the diameter specification (Can be set in only the axis under diameter programming)

1 : Set by the radius specification

	#7	#6	#5	#4	#3	#2	#1	#0
5006								OIM

[Data type] Bit

OIM When the unit is switched between the inch and metric systems, automatic tool compensation value conversion is:

0 : Not performed

1 : Performed

5013	Maximum value of tool wear compensation
------	---

[Data type] Two-word

[Unit of data]	Increment system	IS-A	IS-B	IS-C	Unit
	Metric input	0.01	0.001	0.0001	mm
	Inch input	0.001	0.0001	0.00001	inch

[Valid data range]	Increment system	IS-A	IS-B	IS-C
	Metric input	0 to 99999	0 to 999999	0 to 9999999
	Inch input	0 to 99999	0 to 999999	0 to 9999999

This parameter sets the maximum value of tool wear compensation. The following alarm or warning will be informed when the tool wear compensation (absolute value) exceeding this setting value is set.

Input from MDI	Too many digits
Input by G10	P/S 32 offset value is out of range by G10

5014	Maximum value of incremental input for tool wear compensation
------	---

[Data type] Two-word

[Unit of data]	Increment system	IS-A	IS-B	IS-C	Unit
	Metric input	0.01	0.001	0.0001	mm
	Inch input	0.001	0.0001	0.00001	inch

[Valid data range]	Increment system	IS-A	IS-B	IS-C
	Metric input	0 to 99999	0 to 999999	0 to 9999999
	Inch input	0 to 99999	0 to 999999	0 to 9999999

This parameter sets the maximum value of tool wear compensation at an incremental input. If the incremental value exceeds the set value, the following alarm or warning message is indicated:

Input from MDI	Data is out of range
Input by G10	P/S 32 offset value is out of range by G10

Alarm and message

Number	Message	Description
032	ILLEGAL OFFSET VALUE IN G10	In setting an offset amount by G10 or in writing an offset amount by system variables, the offset amount was excessive.
5300	SET ALL OFFSET DATAS AGAIN	After the inch/metric automatic conversion function (OIM: Bit 0 of parameter No. 5006) for tool offset data is enabled or disabled, all the tool offset data must be reset. This message reminds the operator to reset the data. If this alarm is issued, reset all the tool offset data. Operating the machine without resetting the data will result in a malfunction.

Warning message	Content
DATA IS OUT OF RANGE	The value searched exceeds the permitted range.
TOO MANY DIGITS	The input value exceeds the permitted number of digits.

Note

NOTE

- 1 In the T series (two-path control), the number of specified tool compensation values equals the number of tool compensations for each tool post.
- 2 Even though the number of tool compensation values is more than 64, the maximum number of tool numbers for which the tool post interference check function can indicate or set tool shape data (contact forbidden area) is 64.

10.2.2 Tool Offset Pairs (400 Pairs) and Tool Offset Pairs (999 Pairs) (T Series)

General

This function enhances the maximum number of tool offset to 400 or 999. The tool offset number is specified with the last three digits in T-code value. The tool offset number is specified with the remaining digits after excluding the three digits used to specify the tool offset number. When this function is available, the tool offset number is specified with the last two digits by setting the parameter No.5040#1 to 1.

Display Example

The display of the offset screen is as follows.

OFFSET / WEAR		O0000 N00000		
NO.	X	Z	R	T
W 001	1234.567	-1234.567	0.001	7
W 002	0.000	0.000	0.000	0
W 003	0.000	0.000	0.000	0
W 004	0.000	0.000	0.000	0
W 005	0.000	0.000	0.000	0
W 006	0.000	0.000	0.000	0
W 007	0.000	0.000	0.000	0
W 008	0.000	0.000	0.000	0
ACTUAL POSITION (RELATIVE)				
U	0.000	W	0.000	
H	0.000	V	0.000	
} ^				
MDI **** * * * * 14:29:01				
<div style="display: flex; justify-content: space-between; border: 1px solid black; padding: 2px;"> WEAR GEOM (OPRT) </div>				

OFFSET / WEAR		O0000 N00000		
NO.	Y			
W 001	1234.567			
W 002	0.000			
W 003	0.000			
W 004	0.000			
W 005	0.000			
W 006	0.000			
W 007	0.000			
W 008	-1234.567			
ACTUAL POSITION (RELATIVE)				
U	0.000	W	0.000	
H	0.000	V	0.000	
} ^				
MDI **** * * * * 14:29:38				
<div style="display: flex; justify-content: space-between; border: 1px solid black; padding: 2px;"> WEAR GEOM (OPRT) </div>				

The above examples are cases where the geometry/wear compensation, the tool nose radius compensation, the tool offset value 7 digits, and the Y-axis offset are available.

System Variables (Custom Macro)

System variables can be used to read and write tool compensation values. System variables for 999 tool compensation values are as follows.

	Compensation number	Wear	Geometry
X-axis compensation values	1 : 999	#10001 : #10999	#15001 : #15999
Z-axis compensation values	1 : 999	#11001 : #11999	#16001 : #16999
Tool nose radius compensation values	1 : 999	#12001 : #12999	#17001 : #17999
Imaginary tool nose position T	1 : 999	#13001 : #13999	
Y-axis compensation values	1 : 999	#14001 : #14999	#19001 : #19999

Input of Tool Offset Value Measured B

In the input of tool offset value measured B function, OFN0 to OFN5(G0039#0 to #5) and OFN6 to OFN9(G0040#0 to #3) are used for the tool offset number select signal.

Moreover, the parameter No.5020 and No.5053 are invalid. Use the parameter No. 5023 and No.5052.

Parameter

5023

Tool offset number used for the input of tool offset value measured B
(For tool offset 400 and 999)

[Data type] Word

[Valid data range] 0 to the number of tools to be compensated.

Set tool offset number used for the input of tool offset value measured B function (i.e. when workpiece coordinate system shift value is set). (The tool offset number corresponding to the measured tool shall be set in advance.)

NOTE

- 1 This parameter is valid when the tool offset 400 pairs or 999 pairs is available
- 2 This parameter is valid when the tool offset number is not automatically selected (No.5005#5(QNI) is zero).

5052	Bias for tool offset numbers for measured tool offset value setting (For tool offset 400 and 999)
------	--

[Data type] Word

[Valid data range] 1 to maximum tool offset count.

When the tool setter function for 1-turret, 2-spindle lathes is used, this parameter allocates tool offset numbers for measured tool offset measurement values to spindle 1 and spindle 2.

If 0 is set for this parameter, or if the maximum tool offset count is exceeded, the following is assumed:

	Tool offset number		
	99 pairs (O2DGT=1)	400 pairs	999 pairs
Spindle 1	1 to 49	1 to 200	1 to 499
Spindle 2	50 to 99	201 to 400	500 to 999

NOTE
This parameter is valid when the tool offset 400 or 999 function is available.

Signal

	#7	#6	#5	#4	#3	#2	#1	#0
G039			OFN5	OFN4	OFN3	OFN2	OFN1	OFN0
G040					OFN9	OFN8	OFN7	OFN6

[Classification] Input signal

[Function] Selects the tool offset number.

[Operation] When the mode for writing tool compensation is selected, the cursor is automatically positioned on the tool geometry compensation number selected by these signals. A tool offset number is specified by 10-bit binary number. Number 0 to 998 corresponds to the compensation number 1 to 999.

NOTE
This signal is available only when parameter QNI (No.5005#5) =1.

Tool Life Management

- **T code for registering tools**

T-code for registering tools consists of eight digits or less when the tool offset 400 pairs or 999 pairs is available. And the last three digits is used as the tool offset number.

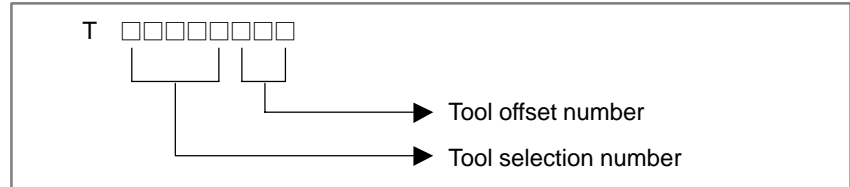

NOTE

When this function is available, the last two digits are used to specify the offset number by the parameter setting (No.5040#1).

- **Tool Life Management Data Screen**

The display of the tool life management data screen is as follows when the tool offset 400 pairs or 999 pairs, which is the optional function, is used.

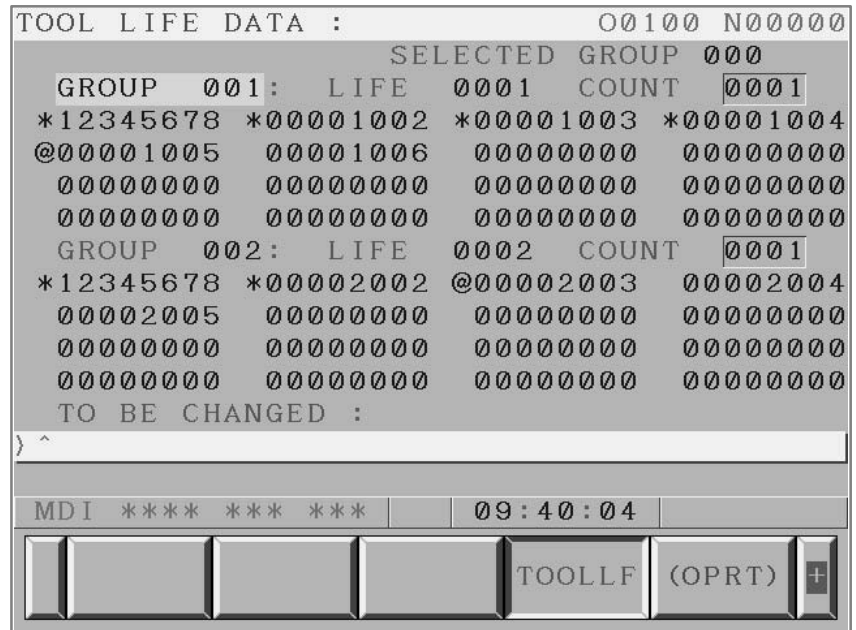

● **Specifying a Tool Group is a Machining Program**

The tool group is specified as follows when the tool offset 400 pairs or 999 pairs is available.

TΔΔ999 . . End the tool used by now, and starts to use the tool of the ΔΔgroup. "999" distinguishes this specification from ordinary specification.

TΔΔ888 . . Cancels the offset of the tool of the group."888" distinguishes this specification from ordinary specification.

NOTE

In machining programs, T codes are used specify tool groups as follows "TΔΔ99 or TΔΔ88", when the last two digits are used to specify the offset number by the parameter setting (No.5040#1).

Other Function

- 2nd geometry offset function
The number of the 2nd geometry offset is 16 irrespective of this function.
- B-axis offset function
The number of B-axis offset is 10 irrespective of this function.

Parameter

	#7	#6	#5	#4	#3	#2	#1	#0
5040							O2DGT	

- O2DGT** When the tool offset 400 pairs or 999 pairs is available,
- 0 : The last three digits are used to designate the offset number. (Maximum 400 or 999)
 - 1 : The last two digits are used to designate the offset number. (Maximum 99)

NOTE

This parameter is valid when tool offset 400 pairs or 999 pairs is available.

Note**NOTE**

- 1 The tool offset 400 pairs and 999 pairs are optional functions.
- 2 The function codes, which have relation to the tool life management in PMC window functions, cannot be used
<Function code> 38 to 49, 160, 163 to 173, 200 to 202
227 to 231, 324 to 328
- 3 The Focas1 Library and the Basic Operation Package on and before the following edition are not prepared for this function.

FOCAS1/HSSB Library (FS160 <i>i</i> /180 <i>i</i> /210 <i>i</i>)	A02B-0207-K730	Edition 1.9
FOCAS1/HSSB Library (FS160 <i>is</i> /180 <i>is</i> /210 <i>is</i>)	A02B-0207-K731	Edition 2.4
Basic Operation Package1 (FOCAS1/HSSB: FS160 <i>i</i> /180 <i>i</i> /210 <i>i</i>)	A02B-0207-K750	Edition 1.9
FOCAS1/Ethernet Library (FS16 <i>i</i> /18 <i>i</i> /21 <i>i</i>)	A02B-0207-K732	Edition 1.4
FOCAS1/Ethernet Library (FS160 <i>is</i> /180 <i>is</i> /210 <i>is</i>)	A02B-0207-K734	Edition 2.2
Basic Operation Package1 (FOCAS1/Ethernet: FS16 <i>i</i> /18 <i>i</i> /21 <i>i</i>)	A02B-0207-K752	Edition 1.1
- 4 Even though the number of tool compensation values is 400 or 999, the maximum number of tool numbers for which the tool post interference check function can indicate or set tool shape data (contact forbidden area) is 64.

Reference item

Series 16 <i>i</i> /18 <i>i</i> /160 <i>i</i> /180 <i>i</i> / 160 <i>s</i> /180 <i>s</i>	OPERATOR'S MANUAL (For Machining Center) (B-63534EN)	II.14.8	TOOL COMPENSATION VAL- UES, NUMBER OF COM- PENSATION VALUES, AND EN- TERING VALUES FROM THE PROGRAM (G10)
	OPERATOR'S MANUAL (For Lathe) (B-63524EN)	II.14.5	TOOL COMPENSATION VAL- UES, NUMBER OF COM- PENSATION VALUES, AND EN- TERING VALUES FROM THE PROGRAM (G10)
Series 21 <i>i</i> /210 <i>i</i> /210 <i>s</i>	OPERATOR'S MANUAL (For Machining Center) (B-63614EN)	II.14.6	TOOL COMPENSATION VAL- UES, NUMBER OF COM- PENSATION VALUES, AND EN- TERING VALUES FROM THE PROGRAM (G10)
	OPERATOR'S MANUAL (For Lathe) (B-63604EN)	II.14.4	TOOL COMPENSATION VAL- UES, NUMBER OF COM- PENSATION VALUES, AND EN- TERING VALUES FROM THE PROGRAM (G10)
Series 20 <i>i</i>	OPERATOR'S MANUAL (For Manual Milling Machine) (B-64204EN)	II.14.4	TOOL COMPENSATION VAL- UES, NUMBER OF COM- PENSATION VALUES, AND EN- TERING VALUES FROM THE PROGRAM (G10)
	OPERATOR'S MANUAL (For Manual Lathes) (B-64194EN)	II.14.4	TOOL COMPENSATION VAL- UES, NUMBER OF COM- PENSATION VALUES, AND EN- TERING VALUES FROM THE PROGRAM (G10)

10.3 TOOL LIFE MANAGEMENT

10.3.1 Tool life management

General

When tools are classified into several groups, average tool life (No. of uses or time) is designated for each group. Whenever a tool is used, the usage time is subtracted from the tool life; when the tool life expires, the next tool in the group is selected. The tool sequence within a group is arranged in advance.

Signal

The end of a tool's life is reported by tool change signal TLCH or individual tool change signal TLCHI. Tool change signal TLCH is set to 1 at the end of the life of the last tool of a group. Individual tool change signal TLCHI is set to 1 at the end of the life of the current tool.

Tool change signal TLCH <F064#0>

[Classification] Output signal

[Function] Reports the end of the life of the last tool of a group.

[Output condition] The signal is set to 1 when:

- The life of the last tool of a group ends, after tool change has been performed each time the end of the life of each tool in a group is detected.

The signal is set to 0 when:

- Tool-change reset is completed for all groups in which no available tools remain.

NOTE

The TLCH signal turns to "1" when the CNC is reset by M02 or M30, for instance after the tool life, based on the frequency of times used, is reached. When tool life is specified by usage time, TLCH turns to "1" when the tool life limit is reached. The signal will change during machine operation, but machining will continue until the end of the program.

Tool change reset signal TLRST <G048#7>

[Classification] Input signal

[Function] Clears all executable data, including the life count of the group, *, and @. To clear the data, specify a group number by tool group number selection signal after replacing the worn-out tools that are displayed on the CRT. The data can also be cleared from the MDI.

[Operation] When the signal is set to 1, the control unit operates as follows:

- Clears all executable data, including the life count of the group.

If the same group is specified after machining is resumed, the first tool in the group is selected.

NOTE

Tool change reset signal TLRST is valid only when the automatic operating signal OP is "0".

Individual tool change signal TLCHI <F064#2> (M series)

[Classification] Output signal

[Function] Reports the end of the life of the current tool. The following processing can be programmed: A running program is interrupted by a tool-change program when the signal turns to "1". Execution of the interrupted program is resumed when the tool is changed.

[Output condition] The signal is set to "1" when:

- The end of the life of the current tool is detected.

The signal is set to "0" when:

- Individual tool-change reset is executed.

Individual tool change reset signal TLRSTI <G048#6> (M series)

[Classification] Input signal

[Function] Sets the individual tool change signal TLCHI to "0".

[Operation] When the signal is set to "1", the control unit operates as follows:

- Sets the individual tool change signal to "0".

NOTE

- 1 These signals are valid only when tool life management is performed on the basis of the tool life calculated in terms of time or cutting length.
- 2 Individual tool change signal TLCHI is not cleared by reset.

Tool skip signal TLSKP <G048#5>

[Classification] Input signal

[Function] A tool which has not reached its lifespan may be changed by one of two methods:

- (i) Designate the group number for the tool by tool group number selection signal then turn the tool skip signal TLSKP to “1”. The next T-code command will pass over the current tool in the group for which the skip was designated, and select the next tool.
- (ii) Turn the TLSKP signal to “1” without designating a group number, and the machine will skip to the next tool in the group currently in use.

Either of these methods is set using parameter SIG (No. 6800#3). Tool life is counted from zero. When the TLSKP signal is “1” and the last tool in the group is being used, the TLCH signal turns to “1”.

[Operation] When the signal is set to “1”, the control unit operates as follows:

- Selects the next tool in the group for which a skip is specified with the next T code.
- Assumes the number of the group to which the current tool belongs.

CAUTION

The cycle start lamp signal (STL) and feed hold lamp signal (SPL) must both be “0” before inputting the TLSKP signal.

New tool select signal TLNW <F064#1>

[Classification] Output signal

[Function] Reports that a new tool of a certain group is selected.

This signal can be used when, for example, a compensation value is to be measured automatically when a new tool is selected.

The new tool select signal is issued at the same timing as TF (tool function strobe signal).

[Output condition] The signal is set to “1” when:

- A new tool of a certain group is selected.

The signal is set to “0” when:

- The completion signal is set to “1”.

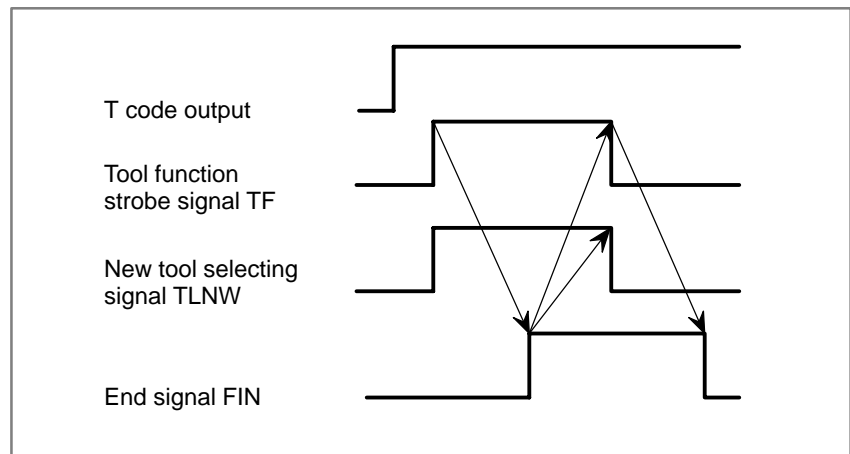

**Tool group number
select signal**
TL01 to TL256 (M series)
<G047#0 to G048#0>
TL01 to TL64
<G47#0 to #6> (T series)

[Classification] Input signal

[Function] When the TLRST or TLSKP signals are input, the tool group number must be given in advance, using the tool group number selection signals TL01 to TL64 (T series) or TL01 to TL256 (M series).

Command the following value in binary form:

Tool group number to be specified –1

[Operation] A specified tool group is selected.

**Tool life count override
signal *TLV0 to *TLV9**
<G049#0 to G050#1>
(M series)

[Classification] Input signal

[Function] Overrides the life count (time) if parameter LFV (No. 6801#2) is specified.

Each of the ten binary code signals has a unique override value that becomes valid when the signal is set to “0”. The life count is overridden by the sum of the valid override values. The override value can be specified in steps of 0.1, within the range of 0 to 99.9.

$$\text{Override value} = \sum_{i=0}^9 \{2^i \times Vi\}$$

*TLV0	× 0.1
*TLV1	× 0.2
*TLV2	× 0.4
*TLV3	× 0.8
*TLV4	× 1.6
*TLV5	× 3.2
*TLV6	× 6.4
*TLV7	× 12.8
*TLV8	× 25.6
*TLV9	× 51.2

(Example) When *TLV7, *TLV6, and *TLV3 are set to “0”, the override value is calculated as follows:

$$12.8 + 6.4 + 0.8 = 20.0$$

The life count is multiplied by 20.0.

[Operation] The actual cutting time is counted and multiplied by the override value obtained by the signals. The calculated time is used as the basis for tool-life management.

Signal address

	#7	#6	#5	#4	#3	#2	#1	#0
G047	TL128	TL64	TL32	TL16	TL08	TL04	TL02	TL01
G048	TLRST	TLRSTI	TLSKP					TL256
G049	*TLV7	*TLV6	*TLV5	*TLV4	*TLV3	*TLV2	*TLV1	*TLV0
G050							*TLV9	*TLV8
	#7	#6	#5	#4	#3	#2	#1	#0
F064						TLCHI	TLNW	TLCH

Parameter

6800	#7	#6	#5	#4	#3	#2	#1	#0
	M6T	IGI	SNG	GRS	SIG	LTM	GS2	GS1

[Data type] Bit

GS1, GS2 This parameter sets the combination of the number of tool life groups which can be entered, and the number of tools which can be entered per group as shown in the table below.

GS2	GS1	M series		T series	
		Group count	Tool count	Group count	Tool count
0	0	1- 16 1- 64	1- 16 1- 32	1- 16 1- 16	1- 16 1- 32
0	1	1- 32 1-128	1- 8 1- 16	1- 32 1- 32	1- 8 1- 16
1	0	1- 64 1-256	1- 4 1- 8	1- 64 1- 64	1- 4 1- 8
1	1	1-128 1-512	1- 2 1- 4	1- 16 1-128	1- 16 1- 4

Lower side ranges in M series column are for the tool life management of 512 pairs.

Lower side range in T series column are for tool life management of 128 pairs.

LTM Tool life

0 : Specified by the number of times
1 : Specified by time

SIG Group number is

0 : Not input using the tool group number selection signal during tool skip (The current group is specified.)
1 : Input using the tool group signal during tool skip

GRS Tool change reset signal

0 : Clears only the execution data of a specified group
1 : Clears the execution data of all entered groups

SNG Input of the tool skip signal when a tool that is not considered tool life management is selected.

0 : Skips the tool of the group used last or of the specified group (using SIG, #3 of parameter No. 6800).
1 : Ignores a tool skip signal

IGI Tool back number

0 : Not ignored
1 : Ignored

M6T T code in the same block as M06

0 : Judged as a back number
1 : Judged as a next tool group command

	#7	#6	#5	#4	#3	#2	#1	#0
6801		EXG					TSM	
	M6E	EXT			EMD	LFV		

[Data type] Bit

TSM When a tool takes several tool numbers, life is counted in tool life management:

- 0 : For each of the same tool numbers.
- 1 : For each tool.

LFV Specifies whether life count override is enabled or disabled when the extended tool life management function is used.

- 0 : Disabled
- 1 : Enabled

EMD An asterisk (*) indicating that a tool has been expired is displayed,

- 0 : When the next tool is selected
- 1 : When the tool life is expired

EXG Tool life management data registration by G10 (T series) is:

- 0 : Performed after the data for all tool groups has been cleared.
- 1 : Performed by adding/changing or deleting the data for a specified group.

EXT Specifies whether the extended tool life management function is used.

- 0 : Not used
- 1 : Used

M6E When a T code is specified in the same block as M06

- 0 : The T code is processed as a return number or as a group number selected next. Either is set by parameter M6T No. 6800#7.
- 1 : The tool group life is counted immediately.

	#7	#6	#5	#4	#3	#2	#1	#0
6803							LFE	LGR
							LFE	

NOTE

After this parameter has been set, the power must be turned off then on again for the setting to become effective.

[Data type] Bit

LGR When the tool life management function is used, a tool life type is:

- 0 : Chosen based on the LTM parameter (bit 2 of parameter No.6800) for all groups.
- 1 : Set to either count or duration on a group-by-group basis.

When LGR is set to 1, the specification of address Q is added to the G10 (tool life management data setting) command format. As shown in the example below, specify the tool life of each group as either a count or a duration. If address Q is omitted for a group, the specification of the LTM parameter (bit 2 of parameter No.6800) applies to the group.

Example: When the LTM parameter (bit 2 of parameter No.6800) is set to 0

```
G10 L3 ;
P1 L10 Q1 ; (Q1: The life of group 1 is specified as a count.)
:
P2 L20 Q2 ; (Q2: The life of group 2 is specified as a duration.)
:
P3 L20 ;
(Omission of Q: The life of group 3 is specified as a count.)
:
G11 ;
M30 ;
%
```

LFE When a tool life is specified by count:
 0 : A count value from 0 to 9999 can be specified.
 1 : A count value from 0 to 65535 can be specified.

6810	
	Tool life management ignored number

[Data type] Word

[Valid data range] 0 to 9999

This parameter sets the tool life management ignored number.

When the set value is subtracted from a T code, a remainder is used as the tool group number of tool life management when a value exceeding the set value is specified in the T code.

6811	Tool life count restart M code

[Data type] Byte

[Valid data range] 0 to 255 (not including 01, 02, 30, 98, and 99)

When zero is specified, it is ignored.

When the life is specified by the number of times, the tool exchange signal is output when a tool life count restart M code is specified if tool life of at least one tool group is expired. A tool in life is selected in the specified group when a T code command (tool group command) is specified after the tool life count restart M code is specified. A tool life counter is then incremented by one.

When the life is specified by time, a tool in life is selected in the specified group when a T code command (tool group command) is specified after the tool life count restart M code is specified.

Alarm and message

Number	Message	Description
149	FORMAT ERROR IN G10L3	A code other than Q1, Q2, P1 or P2 was specified as the life count type in the extended tool life management.
150	ILLEGAL TOOL GROUP NUMBER	Tool Group No. exceeds the maximum allowable value. Modify the program.
151	TOOL GROUP NUMBER NOT FOUND	The tool group commanded in the machining program is not set. Modify the value of program or parameter.
152	NO SPACE FOR TOOL ENTRY	The number of tools within one group exceeds the maximum value registerable. Modify the number of tools.
153	T-CODE NOT FOUND	In tool life data registration, a T code was not specified where one should be. Correct the program.
154	NOT USING TOOL IN LIFE GROUP (M series)	When the group is not commanded, H99 or D99 was commanded. Correct the program.
155	ILLEGAL T-CODE IN M06 (M series)	In the machining program, M06 and T code in the same block do not correspond to the group in use. Correct the program.
	ILLEGAL T-CODE IN M06 (T series)	In the machining program, M06 and T code in the same block do not correspond to the group in use. Correct the program.
156	P/L COMMAND NOT FOUND	P and L commands are missing at the head of program in which the tool group is set. Correct the program.
157	TOO MANY TOOL GROUPS	The number of tool groups to be set exceeds the maximum allowable value. (See parameter No. 6800 bit 0 and 1) Modify the program.
158	ILLEGAL TOOL LIFE DATA	The tool life to be set is too excessive. Modify the setting value.
159	TOOL DATA SETTING INCOMPLETE	During executing a life data setting program, power was turned off. Set again.

Reference item

Series 16i/18i/160i/180i/ 160is/180is	OPERATOR'S MANUAL (For Machining Center) (B-63534EN)	II.10.2	Tool Life Management Function
	OPERATOR'S MANUAL (For Lathe) (B-63524EN)	II.10.2	Tool Life Management Function
Series 21i/210i/210is	OPERATOR'S MANUAL (For Machining Center) (B-63614EN)	II.10.2	Tool Life Management Function
	OPERATOR'S MANUAL (For Lathe) (B-63604EN)	II.10.2	Tool Life Management Function

10.3.2 Tool Life Management B (M Series)

General

The maximum tool life that can be managed is conventionally 65,535 use counts or 4,300 minutes. Using the tool life management B option extends the maximum tool life that can be managed to 999,999 use counts or 100,000 minutes.

In addition, tool life management groups are specified conventionally with a T code for a set of a tool life management invalidation number and a group number. With tool life management B, the tool group number arbitrary setting function (bit 5 of parameter No. 6802) can be used to enable arbitrary T codes to be used to specify groups.

Parameter

	#7	#6	#5	#4	#3	#2	#1	#0
6802			TGN					

[Data type] Bit

TGN Specifies whether to use the group number arbitrary setting function with tool life management B, as follows:

0 : Not to use.

1 : To use.

NOTE

If the group number arbitrary setting function is not used, the tool life management invalidation number (parameter No. 6810) is valid. The valid data range is from 0 to 9999 as usual, however.

10.3.3 Tool Life Arrival Notice Signal (M Series)

General

Once the remaining life of tools (to be kept used until new tools are selected) is set up for each group, it becomes possible to check the remaining tool life for the groups. When the actual remaining life of tools becomes shorter than the remaining tool life setting, a signal is output to the PMC.

Signal description

The tool life arrival notice signal TLCHB is used to notify that the actual remaining tool life is shorter than the corresponding remaining tool life setting. This signal is output when "tool life setting (LIFE) – tool life count (COUNT)" reaches the remaining life setting for the group.

Tool life arrival notice signal TLCHB <F064#3>

[Classification] Output signal

[Function] Notifies that the life of the last tool in the group has expired.

[Output condition] This signal is 1 in the following cases:

- The actual remaining life "LIFE – COUNT" is equal to the value set in a parameter → "equal" type
- The actual remaining life "LIFE – COUNT" is less than the value set in a parameter → "less-than" type

This signal is 0 in the following cases:

- The actual remaining life "LIFE – COUNT" is greater than the value set in a parameter → "equal" type
- The actual remaining life "LIFE – COUNT" is equal to the value set in a parameter → "less-than" type

Signal address

	#7	#6	#5	#4	#3	#2	#1	#0
F064						TLCHB		

Parameter

	#7	#6	#5	#4	#3	#2	#1	#0
6802	RMT			ARL	GRP			

[Data type] Bit

GRP As management data for the tool life arrival notice signal (TLCHB):

0 : Parameters Nos. 6844 and 6845 are used.

1 : The value set for each group with the extended tool life management function is used.

NOTE

This parameter is valid only when tool life management B is used.

ARL The tool life arrival notice signal (TLCHB) of tool life management is:

0 : Output for each tool.

1 : Output for the last tool in a group.

NOTE

This parameter is valid only when bit 3 of parameter No. 6802 is set to 1.

RMT Specifies when to turn off the tool life arrival signal TLCHB, as follows:

0 : The actual remaining life is longer than that specified in a parameter ("less than" type).

1 : The actual remaining life is not equal to that specified in a parameter ("equal" type).

10.4 CUTTER COMPENSATION

10.4.1 Cutter Compensation B, C (M Series)

General

When the tool is moved, the tool path can be shifted by the radius of the tool.

To make an offset as large as the radius of the tool, first create an offset vector with a length equal to the radius of the tool (start-up). The offset vector is perpendicular to the tool path. The tail of the vector is on the workpiece side and the head points to the center of the tool.

If a linear interpolation, corner offset (cutter compensation B only), or circular interpolation command is specified after start-up, the tool path can be shifted by the length of the offset vector during machining.

To return the tool to the start point at the end of machining, cancel the cutter compensation mode.

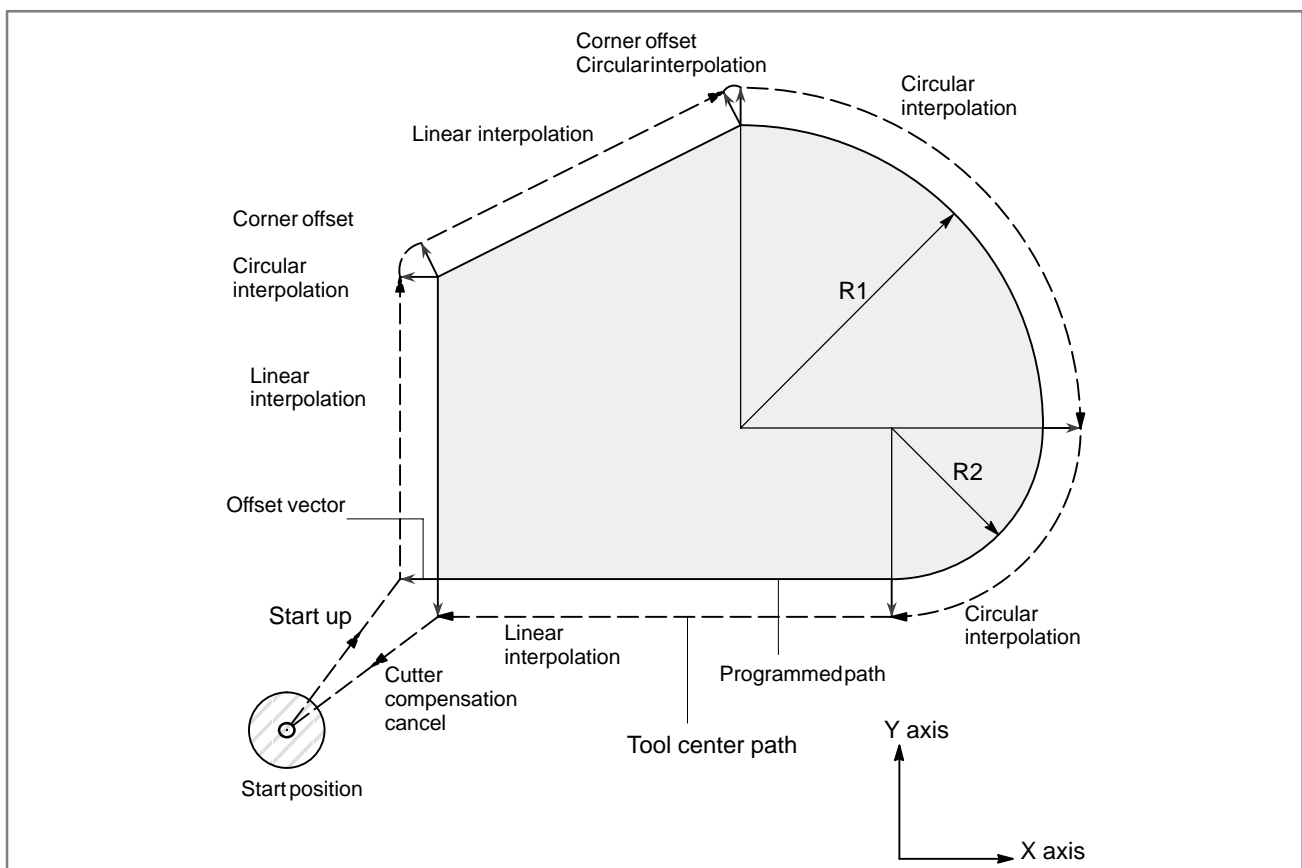

Fig. 10.4.1 (a) Outline of cutter compensation B

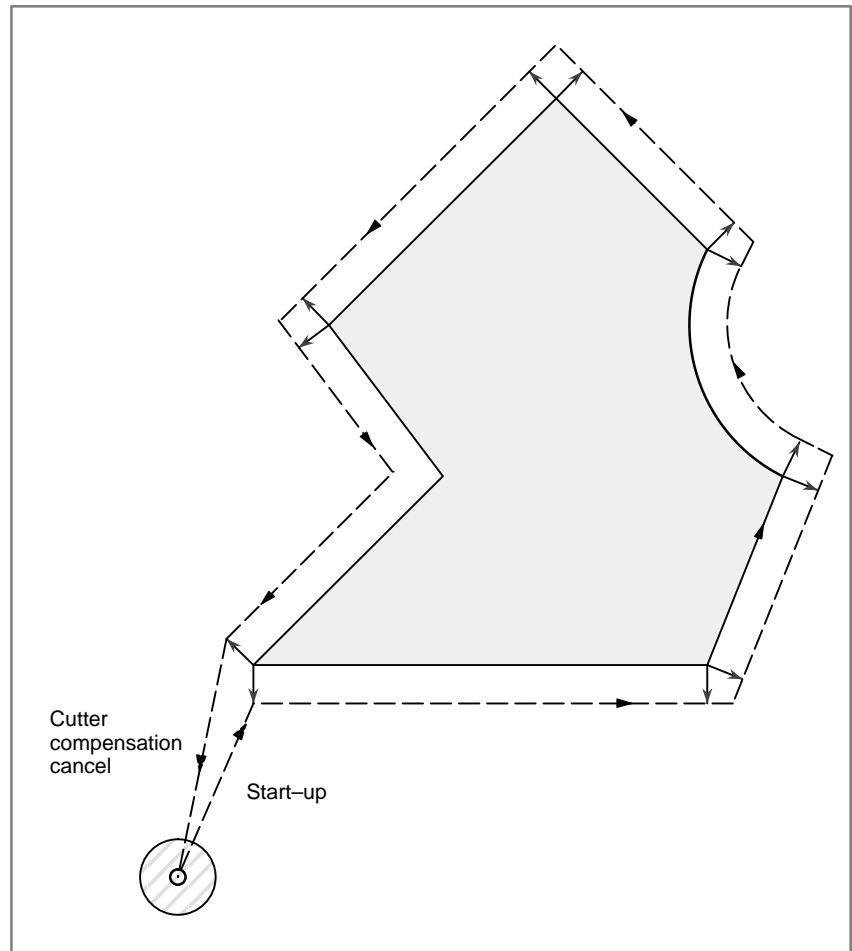

Fig. 10.4.1 (b) Outline of cutter compensation C

Parameter

	#7	#6	#5	#4	#3	#2	#1	#0
5001						OFH		

[Data type] Bit

OFH Offset number of tool length compensation, cutter compensation and tool offset

0 : Specifies the tool length compensation using an H code, and cutter compensation C using a D code

Tool offset conforms to TPH in parameter TPH (No. 5001#5).

1 : Specifies the tool length compensation, cutter compensation and tool offset using H codes

	#7	#6	#5	#4	#3	#2	#1	#0
5003						CCN	SUV	SUP

[Data type] Bit

SUP Start up or cancel in cutter compensation C

0 : Type A

1 : Type B

SUV When G40, G41, and G42 are specified independently,

0 : The start up and cancel operation conforms to the standard specification.

1 : Moves by a distance corresponding to the offset vector which is vertical to the next block movement.

CCN When automatic reference position return (G28) is specified in the cutter compensation C mode (M series) or in tool nose radius compensation (T series):

0 : The cutter compensation vector is cancelled in movement to an intermediate position.

1 : The cutter compensation vector is not cancelled in movement to an intermediate position, but is cancelled in movement to the reference position.

	#7	#6	#5	#4	#3	#2	#1	#0
5008		GCS	QCR	MCR	CNV	G39	CNC	CNI

[Data type] Bit

CNI Interference check for cutter compensation C (M series) or tool-tip radius compensation (T series) is:

0 : Performed

1 : Not performed

CNC During interference check for cutter compensation C (M series) or tool-tip radius compensation (T series), when the direction of movement after application of the offset differs from the programmed direction by between 90° and 270°:

0 : An alarm is issued.

1 : No alarm is issued.

G39 The corner rounding function (G39) in cutter compensation C mode is:

0 : Disabled.

1 : Enabled.

CNV The interference check and vector erasure of cutter compensation C (M series) or tool nose radius compensation (T series) are:

0 : Performed.

1 : Not performed.

MCR If G41/G42 (cutter compensation C (M series) or tool nose radius compensation (T series)) is specified in the MDI mode, an alarm is:

0 : Not raised.

1 : Raised. (P/S5257)

NOTE

In the MDI mode, cutter compensation C (M series) or tool nose radius compensation (T series) is not performed, irrespective of the setting of this parameter.

QCR The travel distance of circular interpolation in cutter compensation C (M series) or tool nose radius compensation (T series) is judged:

0 : In the FS16 format.

1 : In the FS15 format.

FS16 and FS15 determine the travel distance in different ways if the radius of arc at the start point of circular interpolation is different from that at the end point (if the end point is not on the arc). By this parameter, the method of determining the travel distance of circular interpolation can be selected.

[FS16 format]

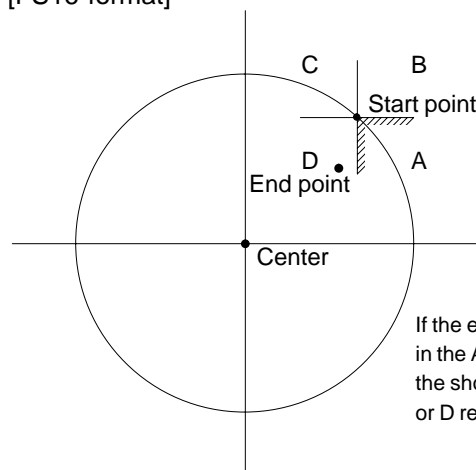

If the end point viewed from the start point is in the A region, the movement is made along the shortcut. If the end point is in the B, C, or D region, almost a single turn is made.

[FS15 format]

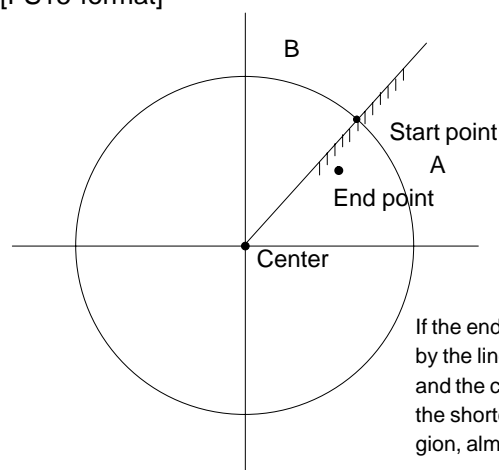

If the end point is in the A region separated by the line L drawn between the start point and the center, the movement is made along the shortcut. If the end point is in the B region, almost a single turn is made.

NOTE

The setting of this parameter determines the travel distance determination method for circular interpolation not during cutter compensation C (M series) or tool nose radius compensation (T series) as well. Accordingly, if this parameter is set, the setting of bit 3 (CQD) of parameter No. 3450 is invalid.

GCS If G49 (G code for canceling tool length compensation) and G40 (G code for canceling cutter compensation) are specified in a single block, the tool length compensation is cancelled:

0 : In the next block.

1 : In the specified block.

5010

Limit value that ignores the vector when a tool moves on the outside of a corner during cutter compensation C

[Data type] Word

[Unit of data]

Increment system	IS-A	IS-B	IS-C	Unit
Metric input	0.01	0.001	0.0001	mm
Inch input	0.001	0.0001	0.00001	inch

[Valid data range] 0 to 16383

This parameter sets the limit value that ignores a slight movement occurring when a tool moves on the outside of the corner during cutter compensation C.

Alarm and message

Number	Message	Description
033	NO SOLUTION AT CRC	A point of intersection cannot be determined for cutter compensation C. Modify the program.
034	NO CIRC ALLOWED IN ST-UP /EXT BLK	The start up or cancel was going to be performed in the G02 or G03 mode in cutter compensation C. Modify the program.
035	CAN NOT COMMANDED G39	G39 is commanded in cutter compensation B cancel mode or on the plane other than offset plane. Modify the program.
036	CAN NOT COMMANDED G31	Skip cutting (G31) was specified in cutter compensation mode. Modify the program.
037	CAN NOT CHANGE PLANE IN CRC	G40 is commanded on the plane other than offset plane in cutter compensation B. The plane selected by using G17, G18 or G19 is changed in cutter compensation C mode. Modify the program.

Number	Message	Description
038	INTERFERENCE IN CIRCULAR BLOCK	Overcutting will occur in cutter compensation C because the arc start point or end point coincides with the arc center. Modify the program.
041	INTERFERENCE IN CRC	Overcutting will occur in cutter compensation C. Two or more blocks are consecutively specified in which functions such as the auxiliary function and dwell functions are performed without movement in the cutter compensation mode. Modify the program.
042	G45/G48 NOT ALLOWED IN CRC	Tool offset (G45 to G48) is commanded in cutter compensation. Modify the program.
5257	G41/G42 NOT ALLOWED IN MDI MODE	G41/G42 (cutter compensation C: M series, tool nose radius compensation: T series) was specified in MDI mode. (Depending on the setting of bit 4 of parameter No. 5008)

Reference item

Series 16i/18i/160i/180i/ 160is/180is	OPERATOR'S MANUAL (For Machining Center) (B-63534EN)	II.14.4	Cutter compensation B
		II.14.5	Cutter compensation C
Series 21i/210i/210is	OPERATOR'S MANUAL (For Machining Center) (B-63614EN)	II.14.4	Cutter compensation C
Series 20i	OPERATOR'S MANUAL (For Manual Milling Machine) (B-64204EN)	II.14.2	Cutter compensation C

10.4.2 Tool Nose Radius Compensation (T Series)

General

It is difficult to produce the compensation necessary to form accurate parts when using only the tool offset function due to tool nose roundness in taper cutting or circular cutting. The tool nose radius compensation function compensates automatically for the above errors.

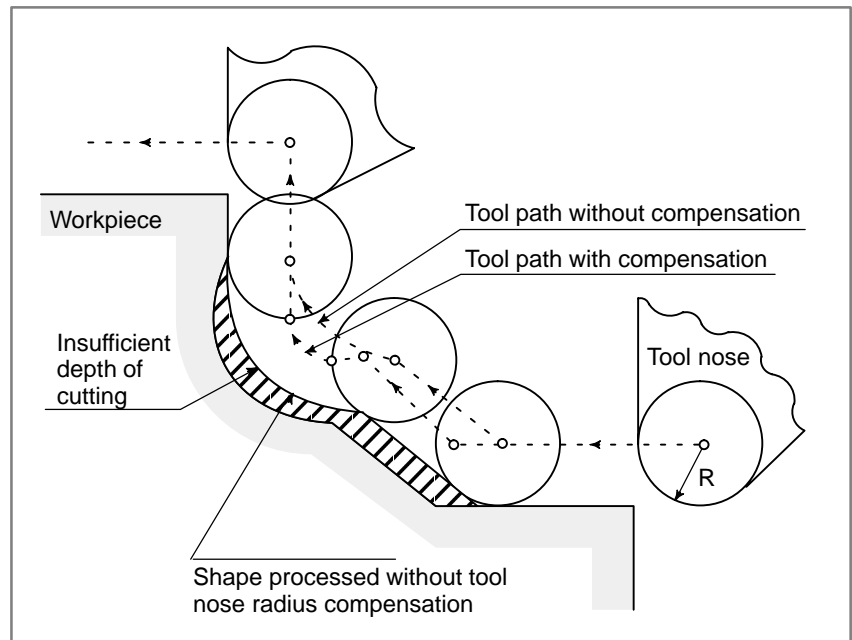

Fig. 10.4.2 Tool path of tool nose radius compensation

Parameter

	#7	#6	#5	#4	#3	#2	#1	#0
5002	WNP							

[Data type] Bit

WNP Imaginary tool tip direction used for tool nose radius compensation, when the geometry/wear compensation option is equipped, is the direction specified by:

- 0 : Geometry offset number
- 1 : Wear offset number

	#7	#6	#5	#4	#3	#2	#1	#0
5003						CCN		

[Data type] Bit

CCN When automatic reference position return (G28) is specified in the cutter compensation C mode (M series) or in tool nose radius compensation (T series):

0 : The cutter compensation vector or tool nose radius compensation vector is cancelled in movement to an intermediate position.

1 : The cutter compensation vector or tool nose radius compensation vector is not cancelled in movement to an intermediate position, but is cancelled in movement to the reference position.

	#7	#6	#5	#4	#3	#2	#1	#0
5008			QCR	MCR	CNV		CNC	CNI

[Data type] Bit

CNI Interference check for cutter compensation C (M series) or tool nose radius compensation (T series) is:

0 : Performed

1 : Not performed

CNC During interference check for cutter compensation C (M series) or tool nose radius compensation (T series), when the direction of movement after application of the offset differs from the programmed direction by between 90° and 270°:

0 : An alarm is issued.

1 : No alarm is issued.

CNV The interference check and vector erasure of cutter compensation C (M series) or tool nose radius compensation (T series) are:

0 : Performed.

1 : Not performed.

MCR If G41/G42 (cutter compensation C (M series) or tool nose radius compensation (T series)) is specified in the MDI mode, an alarm is:

0 : Not raised.

1 : Raised. (P/S5257)

NOTE

In the MDI mode, cutter compensation C (M series) or tool nose radius compensation (T series) is not performed, irrespective of the setting of this parameter.

QCR The travel distance of circular interpolation in cutter compensation C (M series) or tool nose radius compensation (T series) is judged:

0 : In the FS16 format.

1 : In the FS15 format.

FS16 and FS15 determine the travel distance in different ways if the radius of arc at the start point of circular interpolation is different from that at the end point (if the end point is not on the arc). By this parameter, the method of determining the travel distance of circular interpolation can be selected.

[FS16 format]

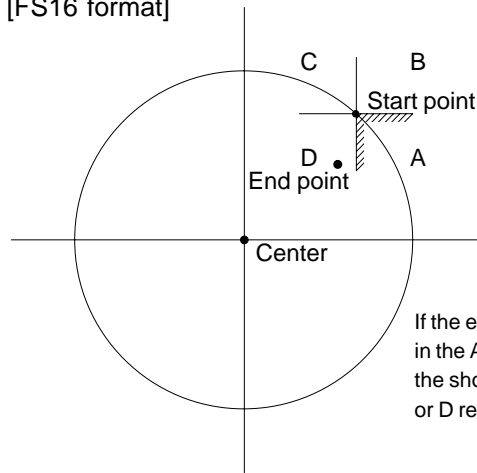

If the end point viewed from the start point is in the A region, the movement is made along the shortcut. If the end point is in the B, C, or D region, almost a single turn is made.

[FS15 format]

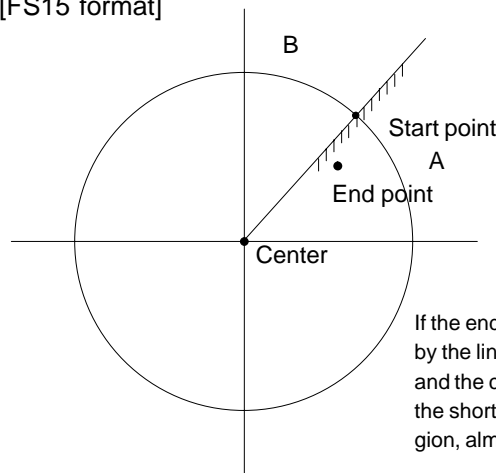

If the end point is in the A region separated by the line L drawn between the start point and the center, the movement is made along the shortcut. If the end point is in the B region, almost a single turn is made.

NOTE

The setting of this parameter determines the travel distance determination method for circular interpolation not during cutter compensation C (M series) or tool nose radius compensation (T series) as well. Accordingly, if this parameter is set, the setting of bit 3 (CQD) of parameter No. 3450 is invalid.

5010	Limit value that ignores the vector when a tool moves on the outside of a corner during tool nose radius compensation
------	---

[Data type] Word

[Unit of data]	Increment system	IS-A	IS-B	IS-C	Unit
	Metric input	0.01	0.001	0.0001	mm
	Inch input	0.001	0.0001	0.00001	inch

[Valid data range] 0 to 16383

This parameter sets the limit value that ignores a slight movement occurring when a tool moves on the outside of a corner during tool nose radius compensation.

Alarm and message

Number	Message	Description
033	NO SOLUTION AT CRC	A point of intersection cannot be determined for tool nose radius compensation. Modify the program. Modify the program.
034	NO CIRC ALLOWED IN ST-UP /EXT BLK	The start up or cancel was going to be performed in the G02 or G03 mode in tool nose radius compensation. Modify the program.
035	CAN NOT COMMANDED G31	Skip cutting (G31) was specified in tool nose radius compensation mode. Modify the program.
037	CAN NOT CHANGE PLANE IN NRC	The offset plane is switched in tool nose radius compensation. Modify the program.
038	INTERFERENCE IN CIRCULAR BLOCK	Overcutting will occur in tool nose radius compensation because the arc start point or end point coincides with the arc center. Modify the program.
039	CHF/CNR NOT ALLOWED IN NRC	Chamfering or corner R was specified with a start-up, a cancel, or switching between G41 and G42 in tool nose radius compensation. The program may cause overcutting to occur in chamfering or corner R. Modify the program.
040	INTERFERENCE IN G90/G94 BLOCK	Overcutting will occur in tool nose radius compensation in canned cycle G90 or G94. Modify the program.
041	INTERFERENCE IN NRC	Overcutting will occur in tool nose radius compensation. Modify the program.
5257	G41/G42 NOT ALLOWED IN MDI MODE	G41/G42 (cutter compensation C: M series, tool nose radius compensation: T series) was specified in MDI mode. (Depending on the setting of bit 4 of parameter No. 5008)

Reference item

Series 16i/18i/160i/180i/160is/180is	OPERATOR'S MANUAL (For Lathe) (B-63524EN)	II.14.2	Tool Nose Radius Compensation
Series 21i/210i/210is	OPERATOR'S MANUAL (For Lathe) (B-63604EN)	II.14.2	Tool Nose Radius Compensation
Series 20i	OPERATOR'S MANUAL (For Manual Lathes) (B-64194EN)	II.14.2	Tool Nose Radius Compensation

10.4.3 Tool Axis Direction Tool Length Compensation (M Series)

10.4.3.1 Tool axis direction tool length compensation

General

When a five-axis machine that has two axes for rotating the tool is used, tool length compensation can be performed in a specified tool axis direction on a rotation axis. When a rotation axis is specified in tool axis direction tool length compensation mode, tool length compensation is applied in a specified tool axis direction on the rotation axis by the compensation value specified in the H code. That is, movement is made along the three linear axes (X_p , Y_p , Z_p).

Unless otherwise noted in the explanation of this function, the two rotation axes are assumed to be the B-axis and C-axis.

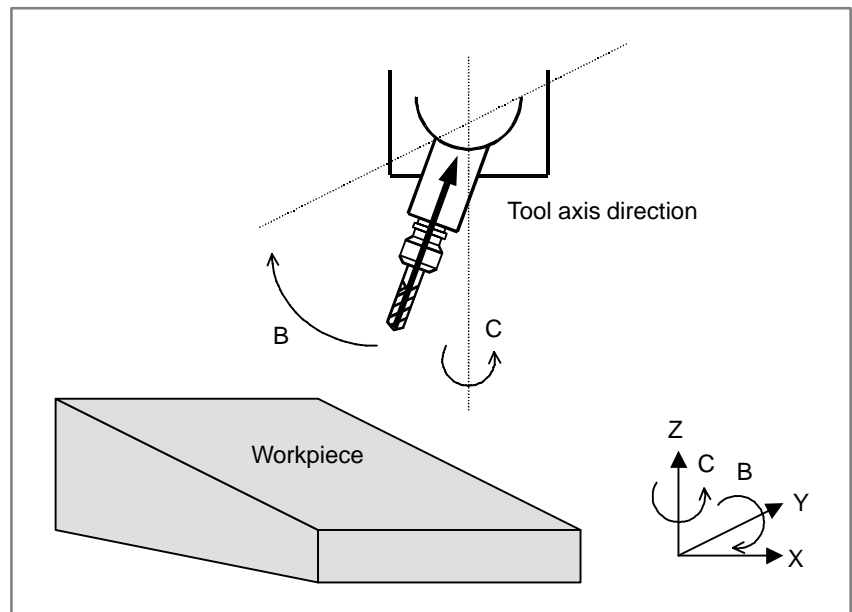

RISC processor is necessary, if this function is used. Refer to Subsection 7.1.19 “RISC Processor Operation,” in this manual too.

Explanation

- **Command for tool axis direction tool length compensation**

The G43.1 Hn command enables tool axis direction tool length compensation.

The tool compensation vector changes as the offset value changes or movement is made on a rotation axis. When the tool compensation vector changes, movement is made according to the change value along the X-axis, Y-axis, and Z-axis.

When the command specifies movement on a rotation axis only, the position of the tool tip is the same both before and after execution of the command. (During rotation axis movement, however, the tool tip moves.)

- **Examples of machine configuration and rotation axis calculation formats**

Let V_x , V_y , V_z , L_c , a , b , and c be as follows :

V_x, V_y, V_z : Tool compensation vectors along the X-axis, Y-axis, and Z-axis

L_c : Offset value

a, b, c : Absolute coordinates on the A-axis, B-axis and C-axis

Then, the tool compensation vector on each axis in each machine configuration is indicated below.

(1) A-axis and C-axis, with the tool axis on the Z-axis

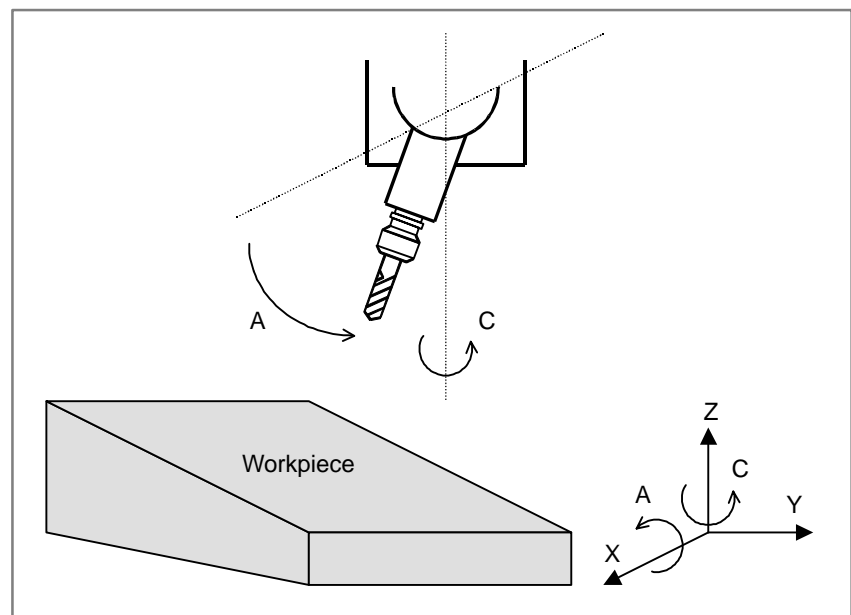

$$V_x = L_c * \sin(a) * \sin(c)$$

$$V_y = -L_c * \sin(a) * \cos(c)$$

$$V_z = L_c * \cos(a)$$

(2) B-axis and C-axis, with the tool axis on the Z-axis

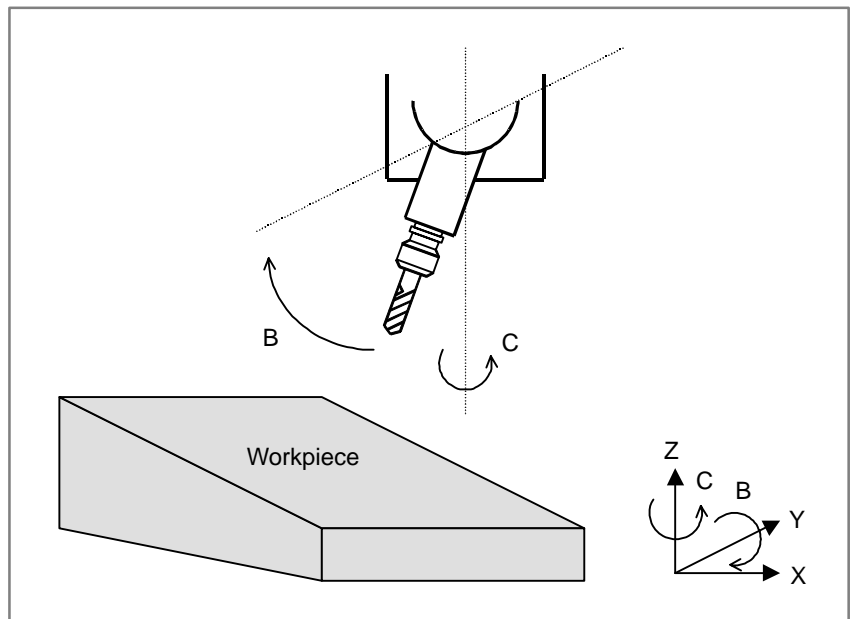

$$V_x = L_c * \sin(b) * \cos(c)$$

$$V_y = L_c * \sin(b) * \sin(c)$$

$$V_z = L_c * \cos(b)$$

(3) A-axis and B-axis, with the tool axis on the X-axis

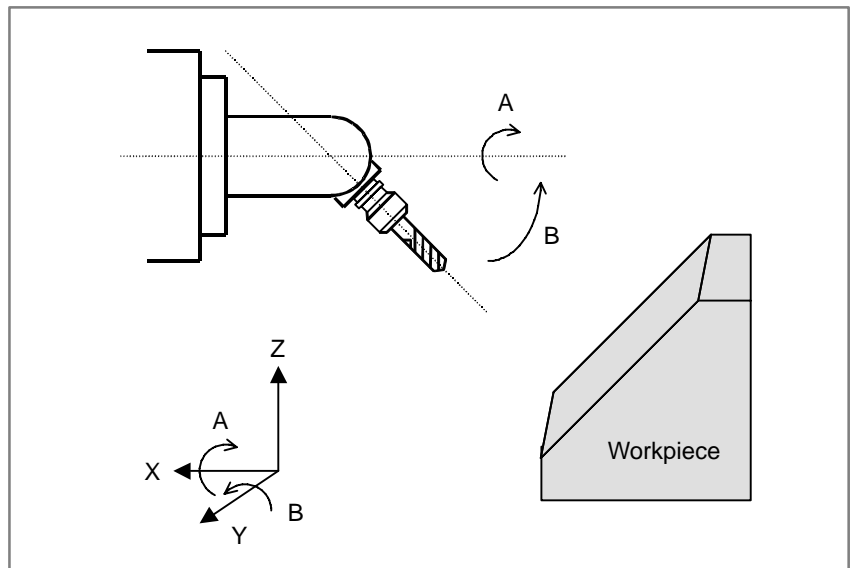

$$V_x = L_c * \cos(b)$$

$$V_y = L_c * \sin(b) * \sin(a)$$

$$V_z = -L_c * \sin(b) * \cos(a)$$

(4) A-axis and B-axis, with the tool axis on the Z-axis, and the B-axis used as the master

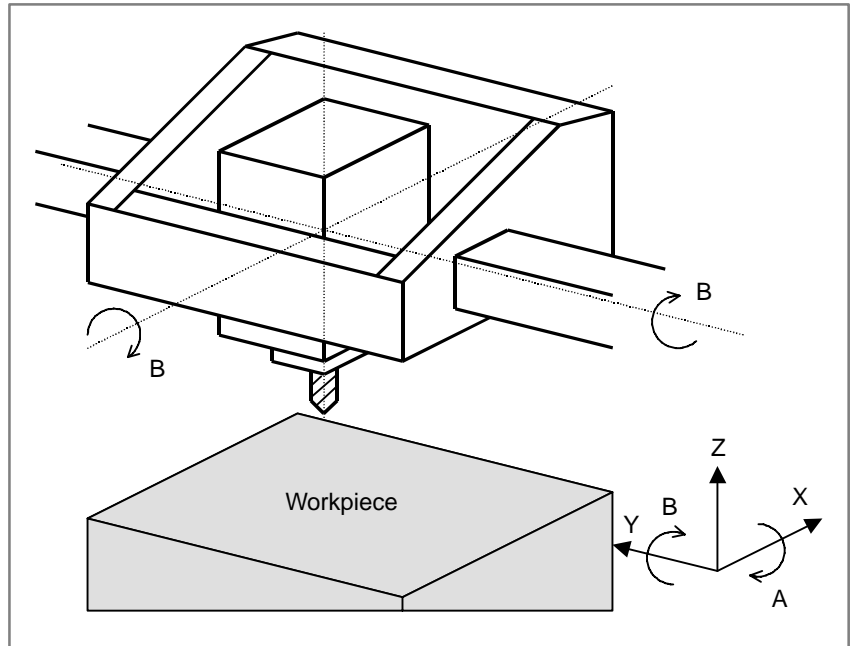

$$V_x = L_c * \cos(a) * \sin(b)$$

$$V_y = -L_c * \sin(a)$$

$$V_z = L_c * \cos(a) * \cos(b)$$

(5) A-axis and B-axis, with the tool axis on the Z-axis, and the A-axis used as the master

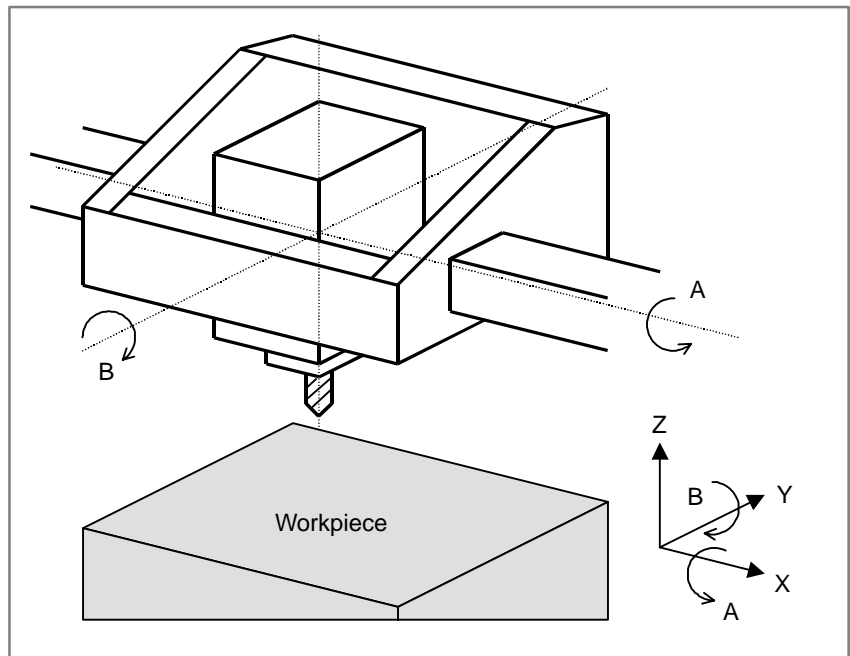

$$V_x = L_c * \sin(b)$$

$$V_y = -L_c * \sin(a) * \cos(b)$$

$$V_z = L_c * \cos(a) * \cos(b)$$

- **Tool holder offset**

The machine-specific length from the rotation center of the tool rotation axes (A- and B-axes, A- and C-axes, and B- and C-axes) to the tool mounting position is referred to as the tool holder offset. Unlike a tool length offset value, a tool holder offset value is set in parameter No. 19666. When tool axis direction tool length compensation is applied, the sum of the tool holder offset and tool length offset is handled as a tool length for compensation calculation.

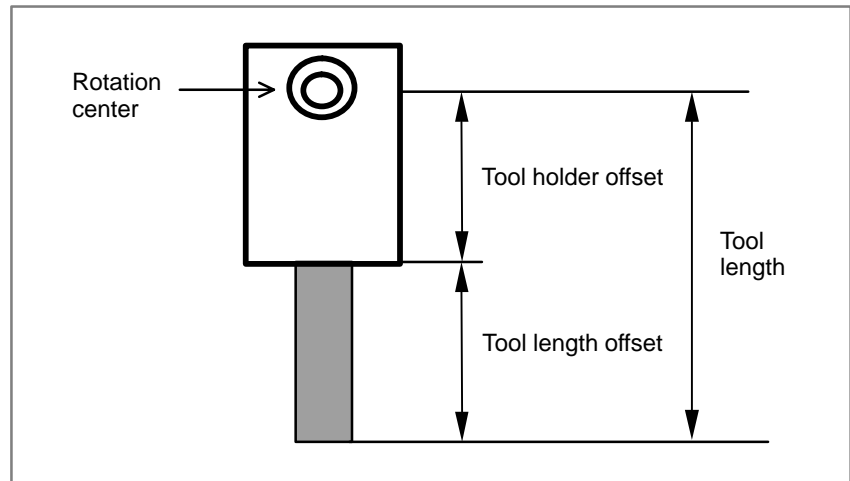

Fig.10.4.3.1 Tool Holder Offset

- **Parameter-based rotation angle specification**

A tool compensation vector is found from the coordinates on the rotation axes for controlling the tool axis direction. However, the configuration of some machines is such that the tool axis is inclined using a fixed attachment. In such a case, the rotation angles of the rotation axes can be set using parameters.

Set bit 1 (RAP) of parameter No. 19650 to 1, and set the coordinates in parameter No. 19658.

- **Rotation axis origin compensation**

This function compensates for a slight shift of the rotation axis origin caused, for example, by thermal displacement. Specify a compensation value in parameter No. 19660.

When the tool axis is on the Z-axis, and the rotation axes are the B-axis and C-axis, a compensation vector is calculated as follows :

$$X_p = L_c * \sin(B-B_z) * \cos(C-C_z)$$

$$Y_p = L_c * \sin(B-B_z) * \sin(C-C_z)$$

$$Z_p = L_c * \cos(B-B_z)$$

X_p, Y_p, Z_p : Compensation pulse on each axis after origin shift compensation

L_c : Offset value

B, C : Machine position on B-axis and C-axis

B_z, C_z : Origin compensation value on B-axis and C-axis

- **Rotation axis offset**

Set offsets relative to the rotation angles of the rotation axes in parameter No. 19659. The compensation vector calculation formula is the same as that used for rotation axis origin compensation, except that B_p and C_p are changed to rotation axis offsets.

When rotation axis origin compensation and rotation offsetting are set at the same time, both compensations are performed.

When the tool axis is on the Z-axis, and the rotation axes are the B-axis and C-axis, compensation vector calculation is performed as follows :

$$X_p = L_c * \sin(B - (B_z + B_o)) * \cos(C - (C_z + C_o))$$

$$Y_p = L_c * \sin(B - (B_z + B_o)) * \sin(C - (C_z + C_o))$$

$$Z_p = L_c * \cos(B - (B_z + B_o))$$

B_z, C_z : B-axis and C-axis origin compensation values

B_o, C_o : B-axis and C-axis rotation axis offset values

10.4.3.2

Control point compensation of tool length compensation along tool axis

General

Normally, the control point of tool length compensation along the tool axis is the point of intersection of the centers of two rotation axes. The machine coordinates also indicate this control point.

This section explains the compensation that is performed when the centers of the two rotation axes do not intersect and also explains how to place the control point at a convenient position on the machine.

Description

● **Compensation of the rotation centers of two rotation axes**

Compensation is performed when the rotation centers of two rotation axes do not match.

The length from the tool mounting position to the first rotation axis center is set as the tool holder offset value in parameter No. 19666.

The vector from the first rotation axis center to the second rotation axis center is set as the rotation center compensation vector in parameter No. 19661. Since parameter No. 19661 is an axis type parameter, the compensation amount for three axes (X, Y, and Z) can be set in this parameter.

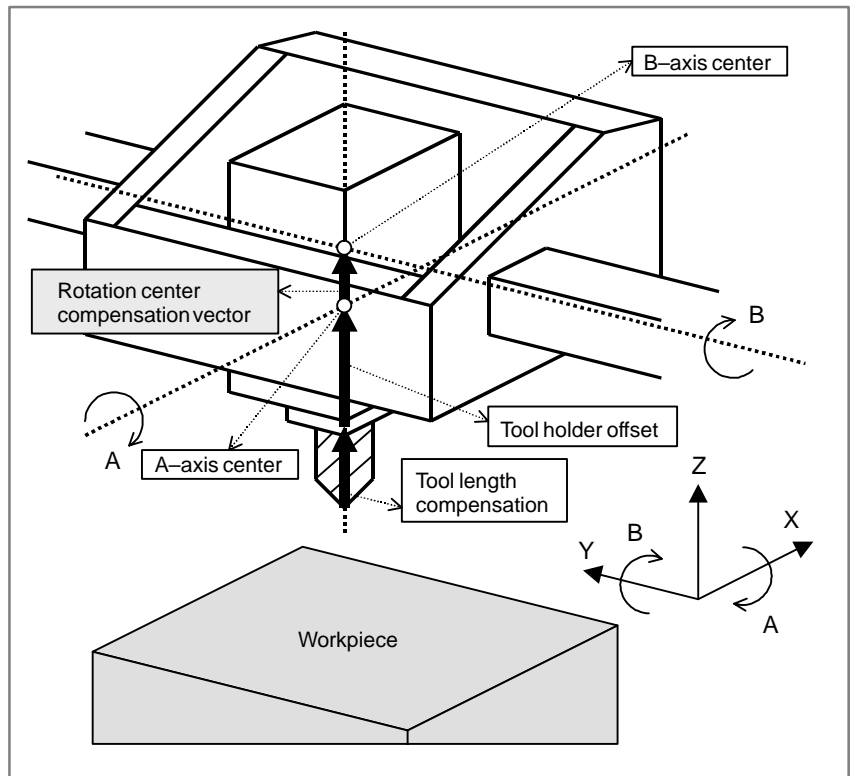

Fig. 10.4.3.2 (a) Compensation of Rotation Centers of Two Rotation Axes

According to the machine type, set the values listed in the following table:

Table 10.4.3.2 (a) Setting the Tool Holder Offset and Rotation Center Compensation Vector

Machine type	Tool holder offsetParameter No. 7548	Rotation center compensation vectorParameter No. 7519
(1) A- and C- axes. Tool axis is Z-axis.	Length from tool mounting position to A-axis center	Vector from A-axis center to C-axis center
(2) B- and C-axes. Tool axis is Z-axis.	Length from tool mounting position to B-axis center	Vector from B-axis center to C-axis center
(3) A- and B-axes. Tool axis is X-axis.	Length from tool mounting position to B-axis center	Vector from B-axis center to A-axis center
(4) A- and B-axes. Tool axis is Z-axis. B-axis is master.	Length from tool mounting position to A-axis center	Vector from A-axis center to B-axis center
(5) A- and B-axes. Tool axis is Z-axis. A-axis is master.	Length from tool mounting position to B-axis center	Vector from B-axis center to A-axis center

NOTE

When using the spindle center compensation described below, set the length from the tool mounting position to the spindle center as the tool holder offset.

● **Spindle center compensation**

Compensation of the spindle center is performed.

The amount of spindle center compensation is set in parameter No. 19662. Since parameter No. 19662 is an axis type parameter, the compensation amount for three axes (X, Y, and Z) can be set in this parameter.

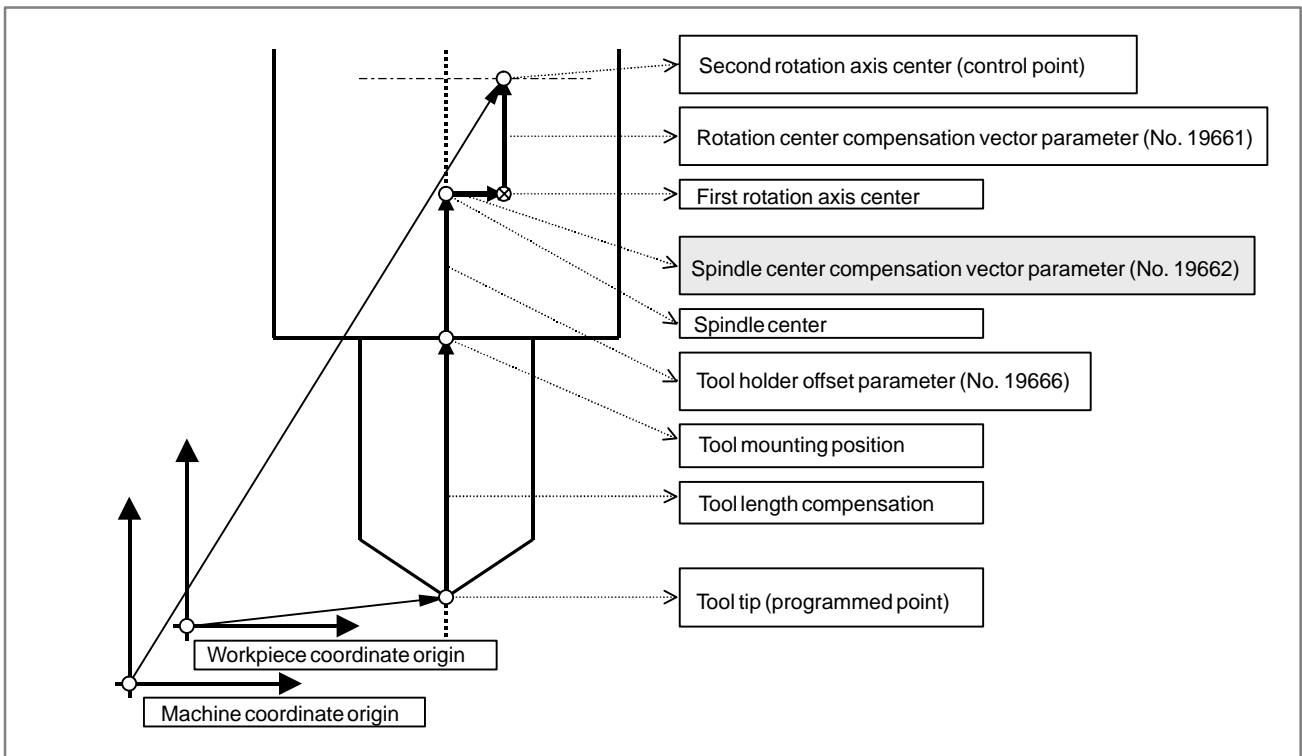

Fig. 10.4.3.2 (b) Spindle Center Compensation

Shifting the control point

Conventionally, the center of a rotation axis was used as the control point. The control point can now be shifted as shown in the figure below. Then, when the rotation axis is at the 0-degree position also in tool length compensation along the tool axis (G43.1), the control point can be set to the same position as in ordinary tool length compensation (G43). The control point here is indicated by machine coordinates. When linear interpolation is specified, for example, this control point moves linearly.

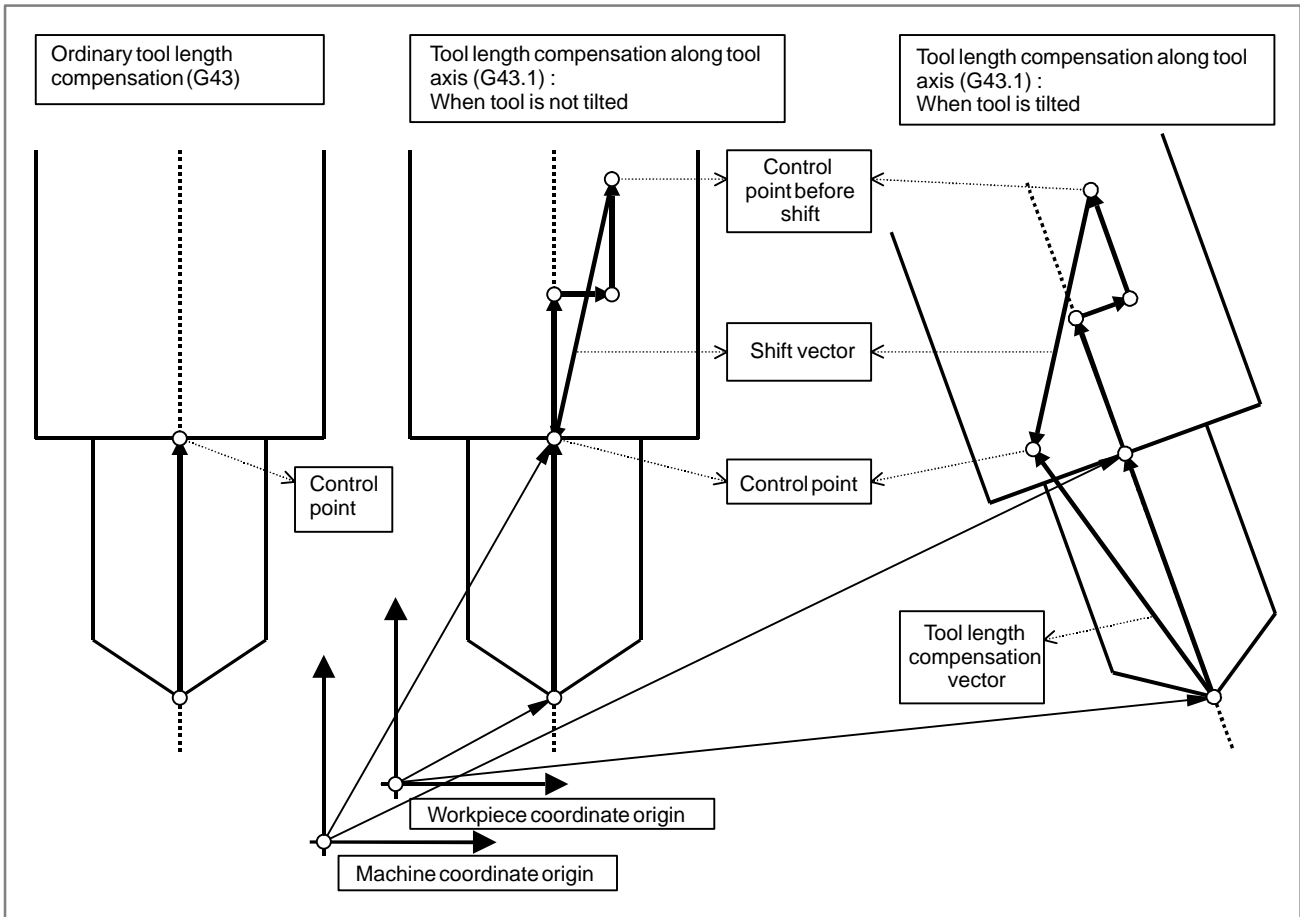

Fig. 10.4.3.2 (c) Shift of Control Point

The method for shifting the control point can be selected using the following parameters:

Table 10.4.3.2 (b) Methods of Shifting the Control Point

Bit 5 (SVC) of parameter No. 19665	Bit 4 (SBP) of parameter No. 19665	Shift of control point
0	–	As normal, the control point is not shifted.
1	0	The control point is shifted, and the shift vector is calculated automatically, as follows: – (rotation center compensation vector (parameter No. 19661)) + spindle center compensation vector (parameter No. 19662)) + tool holder offset along tool axis (parameter No. 19666)))
1	1	The control point is shifted, and the shift vector is the vector set in parameter No. 19667.

● **Expressions for individual machine types**

V_x, V_y, V_z :	Tool length compensation vectors
A, B, C :	Absolute coordinate values for the A-, B-, and C-axes
T_o :	Tool offset value
H_o :	Tool holder offset value
J_x, J_y, J_z :	Rotation center compensation vectors
C_x, C_y, C_z :	Spindle center compensation vectors
S_x, S_y, S_z :	Shift vectors

Assuming the above, axis-specific tool length compensation vectors for individual machine types are obtained as follows:

(1) For the A- and C-axes with the Z-axis as the tool axis

$$\begin{bmatrix} V_x \\ V_y \\ V_z \end{bmatrix} = \begin{bmatrix} \cos C - \sin C 0 \\ \sin C \cos C 0 \\ 0 0 1 \end{bmatrix} \left(\begin{bmatrix} 1 & 0 & 0 \\ 0 & \cos A - \sin A \\ 0 & \sin A & \cos A \end{bmatrix} \begin{bmatrix} C_x \\ C_y \\ C_z \end{bmatrix} + \begin{bmatrix} J_x \\ J_y \\ J_z \end{bmatrix} \right) + \begin{bmatrix} S_x \\ S_y \\ S_z \end{bmatrix}$$

(2) For the B- and C-axes with the Z-axis as the tool axis,

$$\begin{bmatrix} V_x \\ V_y \\ V_z \end{bmatrix} = \begin{bmatrix} \cos C - \sin C 0 \\ \sin C \cos C 0 \\ 0 0 1 \end{bmatrix} \left(\begin{bmatrix} \cos B 0 \sin B \\ 0 0 0 \\ -\sin B 1 \cos B \end{bmatrix} \begin{bmatrix} C_x \\ C_y \\ C_z \end{bmatrix} + \begin{bmatrix} J_x \\ J_y \\ J_z \end{bmatrix} \right) + \begin{bmatrix} S_x \\ S_y \\ S_z \end{bmatrix}$$

(3) For the A- and B-axes with the X-axis as the tool axis

$$\begin{bmatrix} V_x \\ V_y \\ V_z \end{bmatrix} = \begin{bmatrix} 1 & 0 & 0 \\ 0 & \cos A - \sin A \\ 0 & \sin A & \cos A \end{bmatrix} \left(\begin{bmatrix} \cos B 0 \sin B \\ 0 1 0 \\ -\sin B 0 \cos B \end{bmatrix} \begin{bmatrix} T_o + H_o + C_z \\ C_y \\ C_z \end{bmatrix} + \begin{bmatrix} J_x \\ J_y \\ J_z \end{bmatrix} \right) + \begin{bmatrix} S_x \\ S_y \\ S_z \end{bmatrix}$$

(4) For the A- and B-axes with the Z-axis as the tool axis and the B-axis as the master axis

$$\begin{bmatrix} V_x \\ V_y \\ V_z \end{bmatrix} = \begin{bmatrix} \cos B 0 \sin B \\ 0 1 0 \\ -\sin B 0 \cos B \end{bmatrix} \left(\begin{bmatrix} 1 & 0 & 0 \\ 0 & \cos A - \sin A \\ 0 & \sin A & \cos A \end{bmatrix} \begin{bmatrix} C_x \\ C_y \\ C_z \end{bmatrix} + \begin{bmatrix} J_x \\ J_y \\ J_z \end{bmatrix} \right) + \begin{bmatrix} S_x \\ S_y \\ S_z \end{bmatrix}$$

(5) For the A- and B-axes with the Z-axis as the tool axis and the A-axis as the master axis

$$\begin{bmatrix} V_x \\ V_y \\ V_z \end{bmatrix} = \begin{bmatrix} 1 & 0 & 0 \\ 0 & \cos A - \sin A \\ 0 & \sin A & \cos A \end{bmatrix} \left(\begin{bmatrix} \cos B 0 \sin B \\ 0 1 0 \\ -\sin A 0 \cos B \end{bmatrix} \begin{bmatrix} C_x \\ C_x \\ C_z \end{bmatrix} + \begin{bmatrix} J_x \\ J_y \\ J_z \end{bmatrix} \right) + \begin{bmatrix} S_x \\ S_y \\ S_z \end{bmatrix}$$

The shift vectors (S_x, S_y, S_z) are obtained as follows:

(A) 0 if the SVC parameter (bit 5 of parameter No. 19665) is 0

(B) If the SVC parameter (bit 5 of parameter No. 19665) is 1 and the SBP parameter (bit 4 of parameter No. 19665) is 0

If the machine type is not the one mentioned in (3)

$$\begin{bmatrix} S_x \\ S_y \\ S_z \end{bmatrix} = - \begin{bmatrix} C_x + J_x \\ C_y + J_y \\ C_z + J_z + H_o \end{bmatrix}$$

If the machine type is the one mentioned in (3)

$$\begin{bmatrix} S_x \\ S_y \\ S_z \end{bmatrix} = - \begin{bmatrix} C_x + J_x + H_o \\ C_y + J_y \\ C_z + J_z \end{bmatrix}$$

(C) Vector specified in parameter No. 19667 if the SVC parameter (bit 5 of parameter No. 19665) is 1 and the SBP parameter (bit 4 of parameter No. 19665) is 1

Parameter

	#7	#6	#5	#4	#3	#2	#1	#0
19650							RAP	RAM

[Input type] Parameter input

[Data type] Bit axis

RAM Specifies whether to use the axis as the rotation axis for tool axis direction tool length compensation.

0 : Not used as the rotation axis.

1 : Used as the rotation axis.

Select two axes from among rotation axes and set them as the rotation axes for these purposes.

RAP Specifies whether the rotation axis used for tool axis direction tool length compensation.

0 : Ordinary rotation axis.

1 : Parameter axis. The rotation axis is not controlled in designation direction tool length compensation.

If this bit is set to 0, absolute coordinates are used as the coordinates of rotation axes in tool axis direction tool length compensation mode, and machine coordinates are used in three-dimensional handle feed mode. If this bit is set to 1, the value set in parameter No. 19658 is used as the coordinates of the rotation axes.

When there is no rotation axis in the controlled axes, or when there is only one rotation axis in the controlled axes, set 1 in bit 0 (RAM) and bit 1 (RAP) of parameter No. 19650 for the linear axes to which non-existent rotation axes belong, and set an angular displacement in parameter No. 19658.

(Example 1)

There are linear axes X, Y, and Z, and rotation axes A, B, and C which rotate about the X-, Y-, and Z-axes, respectively. The tool axis direction is controlled with the rotation axes A and C.

	RAM (No. 19650#0)
X	0
Y	0
Z	0
A	1
B	0
C	1

(Example 2)

The controlled axes include only the linear axes X, Y, and Z. By using the tool attachment, the tool axis is tilted in the same tool axis direction as when the A- and C-axes are rotated.

	RAM (No. 19650#0)	RAP (No. 19650#1)	Angle (No. 19658)
X	1	1	45000
Y	0	0	0.0
Z	1	1	30000

19655

Axis number of the linear axis to which a rotation axis belongs

[Input type] Parameter input**[Data type]** Word axis**[Valid data range]** 0 – Number of controlled axes

When a rotation axis turns about a linear axis, the linear axis is referred to as an axis to which the rotation axis belongs, and is set using this parameter. For a rotation axis that belongs to no linear axis, or for a linear axis, 0 is set.

Example:

Axis configuration: X, Y, Z, C, A

Linear axis: X, Y, Z

Rotation axis: A (turning about the X-axis), C (turning about the Z-axis)

In the above case, set the following:

Axis number	Axis name	Setting
1	X	0
2	Y	0
3	Z	0
4	C	3
5	A	1

19656

Tool axis direction

[Input type] Parameter input**[Data type]** Word**[Valid data range]** 1 – 3

Enter the tool axis direction when the two rotation axes are set at 0 degree.

Data	Tool axis direction
1	X-axis
2	Y-axis
3	Z-axis

19657	Master rotation axis number
-------	-----------------------------

[Input type] Parameter input

[Data type] Word

[Valid data range] 0 – Number of controlled axes

When a machine does not have the rotation axis that turns about the tool axis, the axis number of a rotation axis used as the master axis is set. For machines not using the master-axis configuration, 0 is set.

When the tool axis direction is controlled by two rotation axes, neither of which turns about the tool axis, one of the rotation axes is mounted on the other rotation axis as shown in the figure below. In this case, the rotation axis on which the other rotation axis is mounted is called the master axis.

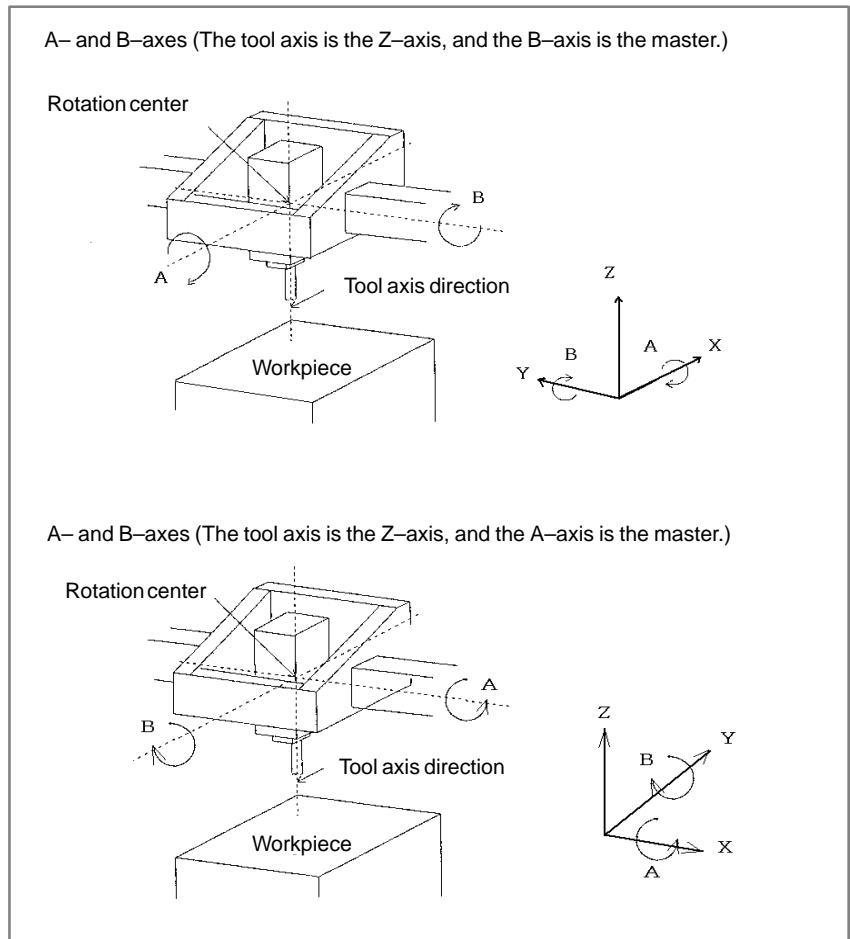

Example for setting parameters that determine the machine configuration

Tool axis direction: Z-axis

Axis configuration: X, Y, Z, W, A, B

Rotation axes: A-axis (axis rotating about the X-axis),

B-axis (axis rotating about the Y-axis)

Master axis: A-axis

Data No.	Data					
19655	X	Y	Z	W	A	B
	0	0	0	0	1	2
19656	3					
19657	5					

19658	Angular displacement of a rotation axis
-------	---

[Input type] Parameter input

[Data type] 2 word axis

[Unit of data] degree

Increment system	IS-A	IS-B	IS-C	Unit
Rotation axis	0.01	0.001	0.0001	deg

[Minimum unit of type] Depend on the increment system of the applied axis

[Valid data range] -99999999 to +99999999

When using the three-dimensional handle feed function or tool axis direction tool length compensation function, set the coordinate of a rotation axis, among the rotation axes determining the tool axis direction, which is not controlled by the CNC. This parameter is enabled or disabled, depending on the setting of bit 1 (RAP) of parameter No. 19650.

19659	Offset value for angular displacement of a rotation axis
-------	--

[Input type] Parameter input

[Data type] 2 word axis

[Unit of data] degree

Increment system	IS-A	IS-B	IS-C	Unit
Rotation axis	0.01	0.001	0.0001	deg

[Minimum unit of type] Depend on the increment system of the applied axis

[Valid data range] -99999999 to +99999999

An offset can be applied to the angular displacement of the three-dimensional handle feed function or tool axis direction tool length compensation function to compensate for the move direction.

19660	Origin offset value of a rotation axis
-------	--

[Input type] Parameter input

[Data type] 2 word axis

[Unit of data] degree

Increment system	IS-A	IS-B	IS-C	Unit
Rotation axis	0.01	0.001	0.0001	deg

[Minimum unit of type] Depend on the increment system of the applied axis

[Valid data range] -99999999 to +99999999

Set an angular displacement shifted from the origin for a rotation axis when the three-dimensional handle feed function or tool axis direction tool length compensation function is used.

19661	Rotation center compensation vector in tool length compensation along tool axis
-------	---

[Input type] Parameter input

[Data type] 2 word axis

[Unit of data] mm, inch (machine unit)

Increment system	IS-A	IS-B	IS-C	Unit
Millimeter machine	0.01	0.001	0.0001	mm
Inch machine	0.001	0.0001	0.00001	inch

[Minimum unit of type] Depend on the increment system of the applied axis

[Valid data range] -99999999 to +99999999

In the function for tool length compensation along the tool axis, set the vector from the first rotation axis center to second rotation axis center.

19662	Spindle center compensation vector in tool length compensation along tool axis
-------	--

[Input type] Parameter input

[Data type] 2 word axis

[Unit of data] mm, inch (machine unit)

Increment system	IS-A	IS-B	IS-C	Unit
Millimeter machine	0.01	0.001	0.0001	mm
Inch machine	0.001	0.0001	0.00001	inch

[Minimum unit of type] Depend on the increment system of the applied axis

[Valid data range] -99999999 to +99999999

In the function for tool length compensation along the tool axis, set the compensation vector of the spindle center.

	#7	#6	#5	#4	#3	#2	#1	#0
19665	ETH		SVC	SBP				

[Input type] Parameter input

[Data type] Bit

SBP In tool length compensation along the tool axis, shift of the control point is:

0 : Calculated automatically.

1 : Set in parameter No. 19667.

SVC In tool length compensation along the tool axis, the control point is:

0 : Not shifted.

1 : Shifted.

The shift method is specified with bit 4 (SBP) of parameter No. 19665.

ETH Specifies whether the tool holder offset function in tool axis direction tool length compensation is useful for the tool length compensation function.

0 : Not useful.

1 : Useful.

19666	Tool holder offset for tool axis direction tool length compensation
-------	---

[Input type] Parameter input

[Data type] 2 word

[Unit of data] mm, inch (machine unit)

Increment system	IS-A	IS-B	IS-C	Unit
Millimeter machine	0.01	0.001	0.0001	mm
Inch machine	0.001	0.0001	0.00001	inch

[Minimum unit of type] Depend on the increment system of the reference axis

[Valid data range] -99999999 to +99999999

Set an offset value (tool holder offset value) for the machine-specific portion from the rotation center of the rotation axis to the tool mounting position when the tool axis direction tool length compensation function is used.

19667	Shift vector in tool length compensation along tool axis
-------	--

[Input type] Parameter input

[Data type] 2 word axis

[Unit of data] mm, inch (machine unit)

Increment system	IS-A	IS-B	IS-C	Unit
Millimeter machine	0.01	0.001	0.0001	mm
Inch machine	0.001	0.0001	0.00001	inch

[Minimum unit of type] Depend on the increment system of the applied axis

[Valid data range] -99999999 to +99999999

In the function for tool length compensation along the tool axis, set the control point shift vector. This parameter is valid when bit 5 (SVC) of parameter No. 19665 is 1 and bit 4 (SBP) of parameter No. 19665 is 1.

Alarm and message

Number	Message	Contents
5196	ILLEGAL AXIS OPERATION	An attempt was made to use a function that cannot be used in the HPCC mode or when a function related to the five axes is being executed.
5435	PARAMETER OUT OF RANGE (TLAC)	The value specified in the parameter is not in the valid range.
5436	PARAMTER SETTING ERROR 1 (TLAC)	The rotation axis specified in the parameter is invalid.
5437	PARAMETER SETTING ERROR 2 (TLAC)	The tool axis specified in the parameter is invalid.

Reference item

Connection manual (This function)	7.1.19	RISC Processor Operation
--------------------------------------	--------	--------------------------

10.4.4 Three-dimensional Cutter Compensation (M series)

General

The three-dimensional cutter compensation function is used with machines that can control the direction of tool axis movement by using rotation axes (such as the B- and C-axes). This function performs cutter compensation by calculating a tool vector from the positions of the rotation axes, then calculating a compensation vector in a plane (compensation plane) that is perpendicular to the tool vector.

There are two types of cutter compensation: Tool side compensation and leading edge compensation. Which is used depends on the type of machining.

Refer to the applicable operator's manual for detailed descriptions about the operation of each function. This subsection focuses on explanations about how to set parameters.

Tool side compensation

Tool side compensation is a type of cutter compensation that performs three-dimensional compensation on a plane (compensation plane) perpendicular to a tool direction vector.

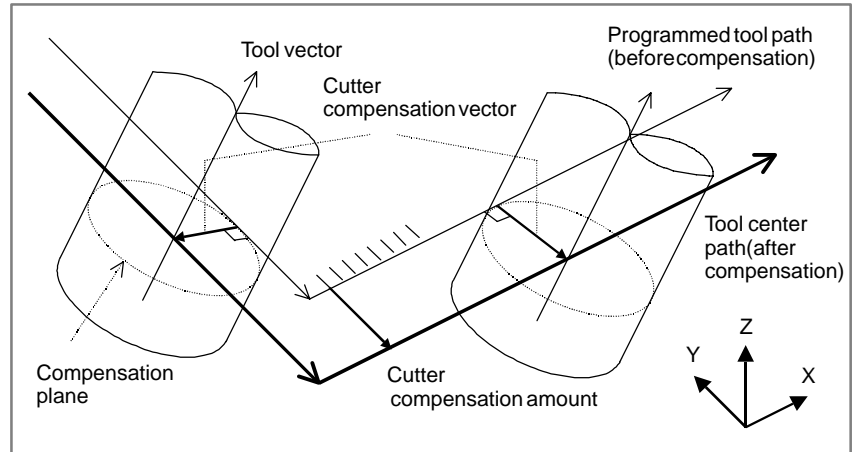

Fig.10.4.4 (a) Tool side compensation

Leading edge offset

Leading edge offset is a type of cutter compensation that is used when a workpiece is machined with the edge of a tool. A tool is automatically shifted by a specified cutter compensation value on the line where a plane formed by a tool direction vector and tool movement direction intersects a plane perpendicular to the tool axis direction.

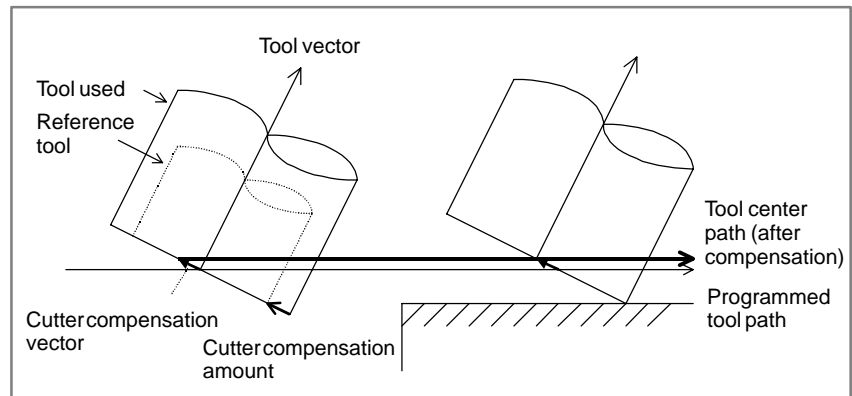

Fig.10.4.4 (b) Reading edge offset

Parameter

(1) Parameters setting the relationship between the rotation axis and rotation plane with which the tool is controlled	
(1) Relationship between the rotation axis and rotation plane	Parameter (No.19610 to 19619)
(2) Direction of the tool axis	Parameter (No.19622 to 19623)
(3) Reference angle for the rotation axis	Parameter (No.19620 to 19621)
(2) Parameters for tool side compensation	
Limit for ignoring the small movement	Parameter (No.19630)
Interference check at compensation plane switching	Parameter NIC (No.19605#5) Parameter (No.19633)
(3) Parameter for leading edge offset	
Angle variation range	Parameter (No.19631)

19610	Rotation axis for three-dimensional cutter compensation and so forth (first group)
19611	Linear axis 1 for three-dimensional cutter compensation and so forth (first group)
19612	Linear axis 2 for three-dimensional cutter compensation and so forth (first group)
19613	Linear axis 3 for three-dimensional cutter compensation and so forth (first group)

[Input type] Parameter input

[Data type] Word

[Valid data range] 0 – Number of controlled axes

Set the rotation axis and linear axes to perform three-dimensional cutter compensation/spindle unit compensation/inclined rotary head tool length compensation (first group).

19614	Angle of inclination for the rotation axis for three-dimensional cutter compensation and so forth (first group)
-------	---

[Input type] Parameter input

[Data type] 2 word

[Unit of data] degree

[Valid data range] –99999999 to +99999999

Set the angle of rotation for the rotation axis to perform three-dimensional cutter compensation/spindle unit compensation/inclined rotary head tool length compensation (first group).

19615	Rotation axis for three-dimensional cutter compensation and so forth (second group)
19616	Linear axis 1 for three-dimensional cutter compensation and so forth (second group)
19617	Linear axis 2 for three-dimensional cutter compensation and so forth (second group)
19618	Linear axis 3 for three-dimensional cutter compensation and so forth (second group)

[Input type] Parameter input

[Data type] Word

[Valid data range] 0 – Number of controlled axes

Set the rotation axis and linear axes to perform three-dimensional cutter compensation/spindle unit compensation/inclined rotary head tool length compensation (second group).

19619	Angle of inclination for the rotation axis for three-dimensional cutter compensation and so forth (second group)
-------	---

[Input type] Parameter input

[Data type] 2 word

[Unit of data] degree

[Valid data range] -99999999 to +99999999

Set the angle of rotation for the rotation axis to perform three-dimensional cutter compensation/spindle unit compensation/inclined rotary head tool length compensation (second group).

Parameter Nos. 19610 to 19619

	First group	Second group
Rotation axis	19610	19615
Linear axis 1	19611	19616
Linear axis 2	19612	19617
Linear axis 3	19613	19618
Angle of inclination	19614	19619

- These parameters set the relationship between the rotation axis and rotation plane.
- Two groups can be set. Therefore, machines controlled with two rotation axes are supported.
- In the calculation of the tool direction, calculation for the rotation axis of the first group is made first, then based on the calculation result, calculation for the rotation axis for the second group is made.
- When two rotation axes are used, the rotation plane may be changed by the rotation of the other rotation axis. In this case, set the rotation plane obtained when the rotation axis position is 0 degrees.

- When there is one rotation axis, set the rotation axis of the second group to 0.
- In general, the direction vector of a rotation axis has three direction components. This function supports direction vectors with one direction component and two direction components. In each case, set the following:
 - A) When the direction vector of a rotation axis has one direction component (type A)

The rotation axis rotates about one of the basic three axes.

 - 1) Set axis numbers for the rotation axis, linear axis 1, and linear axis 2.
 - 2) Set the linear axis 3 and the angle of inclination to 0.
 - 3) The rotation axis is defined as follows:
 - The rotation axis rotates about an axis that perpendicularly intersects the plane formed by linear axis 1 and linear axis 2.
 - When the rotation axis rotates from the positive direction of linear axis 1 to the positive direction of linear axis 2, the rotation axis is said to rotate in the positive direction.

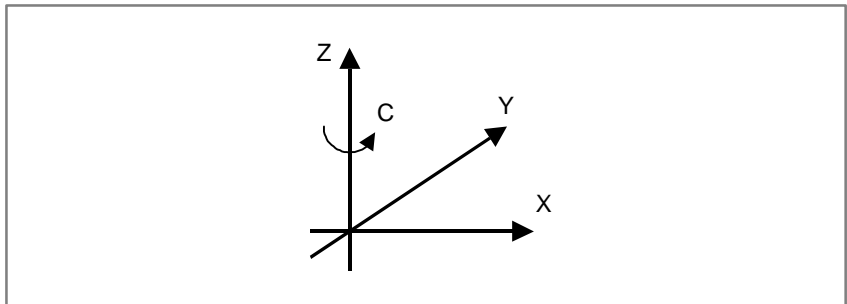

- B) When the direction vector of a rotation axis has two direction components (type B)

The rotation axis rotates about an axis that lies in a plane formed by any two of the basic three axes.

 - 1) Set axis numbers for the rotation axis, linear axis 1, linear axis 2, and linear axis 3.
 - 2) The linear axes 1, 2, and 3 form a right-handed coordinate system in this order.
 - 3) The angle of inclination is defined as follows:
 - Rotation is performed in the plane formed by linear axes 3 and 1.
 - When the rotation axis rotates from the positive direction of linear axis 3 to the positive direction of linear axis 1, the angle of inclination is positive.
 - When the rotation axis and linear axis 3 match, the angle of inclination is 0 degrees.
 - 4) When the angle of inclination is 0 degrees, the rotation axis is defined as follows:
 - The rotation axis rotates about an axis that perpendicularly intersects the plane formed by linear axes 1 and 2.

- When the rotation axis rotates from the positive direction of linear axis 1 to the positive direction of linear axis 2, the rotation axis is said to rotate in the positive direction.

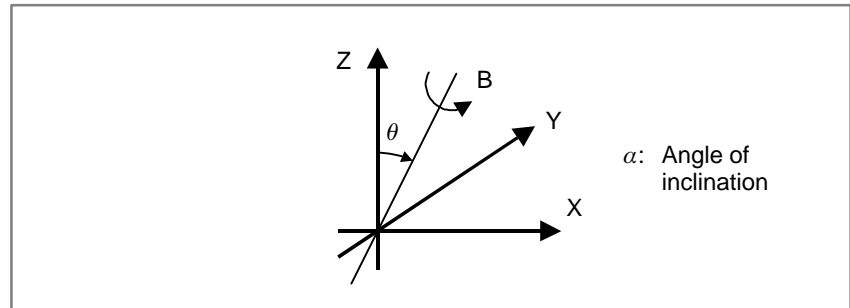

19620	Reference angle for the rotation axis for three-dimensional cutter compensation and so forth (first group)
19621	Reference angle for the rotation axis for three-dimensional cutter compensation and so forth (second group)

[Input type] Parameter input

[Data type] 2 word

[Unit of data] degree

[Valid data range] -99999999 to +99999999

Set a reference angle for the rotation axis to perform three-dimensional cutter compensation/inclined rotary head tool length compensation.

Set an angle for the rotation axis assumed when a tool axis direction (parameter No. 19622 to No. 19623) is set.

Usually, set 0.0.

19622	Reference angle for the tool axis in the plane formed by linear axes 2 and 3 (R_A)
19623	Reference angle for the tool axis in the plane formed by linear axes 3 and 1 (R_B)

[Input type] Parameter input

[Data type] 2 word

[Unit of data] degree

[Valid data range] -99999999 to +99999999

Set the direction of each rotation axis to perform three-dimensional cutter compensation/inclined rotary head tool length compensation by using angles R_A and R_B .

Parameter Nos. 19622 to 19623

The direction of a compensation vector is set by setting an angular displacement (R_A , R_B) from the direction of linear axis 3.

R_A : Rotation is performed in the plane formed by linear axis 2 and linear axis 3. When rotation is performed from the positive direction of linear axis 2 to the positive direction of linear axis 3, the direction of the rotation is positive.

R_B : Rotation is performed in the plane formed by linear axis 3 and linear axis 1. When rotation is performed from the positive direction of linear axis 3 to the positive direction of linear axis 1, the direction of the rotation is positive.

Linear axes 1, 2, and 3 are set in parameter Nos. 19611 to 19613.

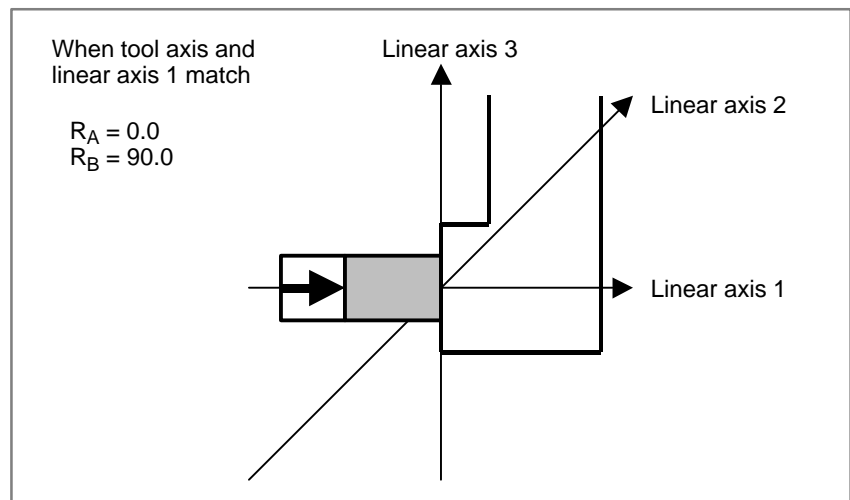
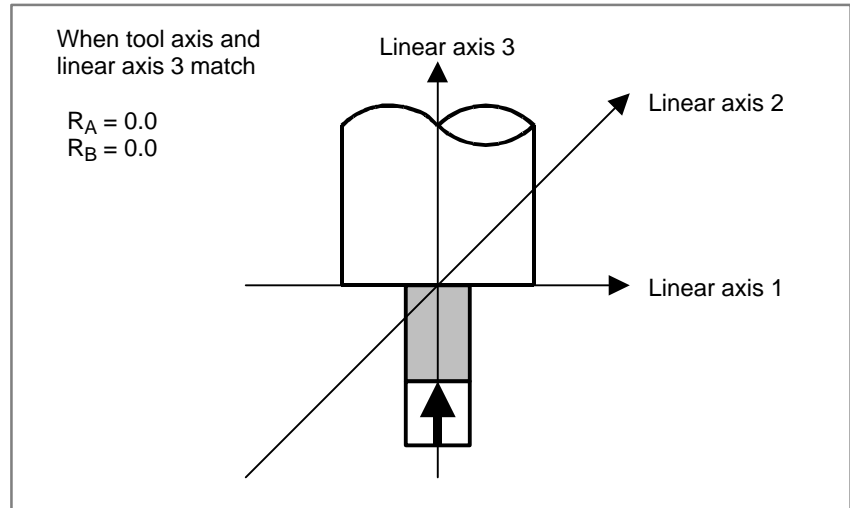

19630

Limit for assuming the block as a non-movement block in intersection calculation for tool side compensation (G41.2, G42.2)

[Input type] Parameter input

[Data type] 2 word

[Unit of data] mm, inch (input unit)

[Valid data range] -99999999 to +99999999

When an intersection calculation is made for tool side compensation, the block is assumed to be a block involving no movement if the difference in the coordinates of two points on the compensation plane is smaller than the value set in this parameter. In such a case, an additional block ahead is read for intersection calculation.

Usually, set a value about 0.01 mm.

	#7	#6	#5	#4	#3	#2	#1	#0
19605			NIC					

[Input type] Parameter input

[Data type] Bit

NIC Specifies whether to perform an interference check when compensation plane switching occurs during three-dimensional cutter compensation.

0 : Perform.

1 : Do not perform.

19635	Effective angle in an interference check for three-dimensional cutter compensation
-------	--

[Input type] Parameter input

[Data type] 2 word

[Unit of data] degree

[Valid data range] -99999999 to +99999999

A tool direction change is assumed when the angle difference between two tool direction vectors in three-dimensional cutter compensation is equal to or greater than the value set in this parameter.

When 0 is set, the specification of 45 degrees is assumed.

Let two tool direction vectors be V_a and V_b . When the difference in angle is α degrees or more as shown in the figure below, the tool direction vector is determined to have been changed.

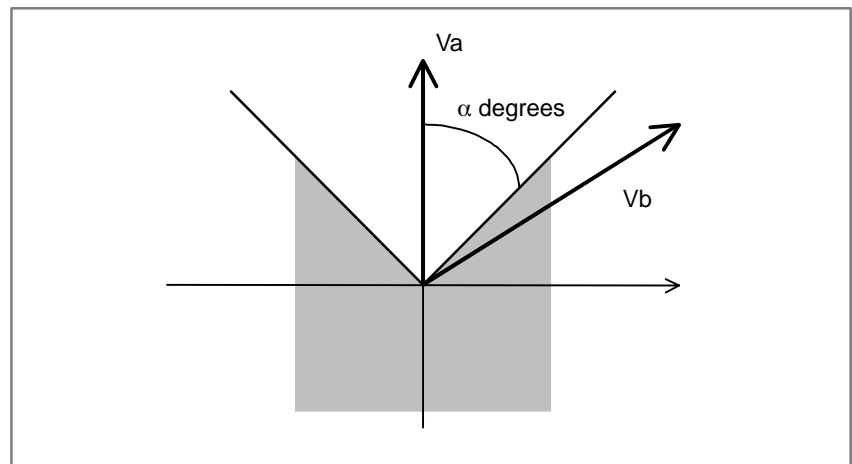

19631

Angle determination fluctuation value for leading edge offset

[Input type] Parameter input**[Data type]** 2 word**[Unit of data]** degree**[Valid data range]** -99999999 to +99999999

This parameter sets a variation range used to determine whether the included angle between the tool direction vector (VT) and move direction vector (VM) is 0° , 180° , or 90° during leading edge offsetting.

For example, let the included angle between VT and VM be θ ($0 \leq \theta \leq 180$), and the angle set in this parameter be $\Delta\theta$. Then, θ is determined as follows:

When $0 \leq \theta \leq \Delta\theta$	$\theta=0^\circ$
When $(180-\Delta\theta) \leq \theta \leq 180$	$\theta=180^\circ$
When $(90-\Delta\theta) \leq \theta \leq (90+\Delta\theta)$	$\theta=90^\circ$

Normally, set around 1.0 in this parameter.

Alarm and message

Number	Message	Contents
0033	CRC:NO INTERSECTION	There is not point of intersection of the compensated tool center path during cutter compensation.
0037	CRC:PLANE CHANGE	An attempt was made to change the plane in the cutter compensation mode.To change the plane, cancel the cutter compensation mode.
0041	CRC:INTERFERENCE	The depth of the cut is too great during cutter compensation. Check the program.The criteria for judging interference are as follows: (1) The direction of movement of the programmed block differs from the direction of movement of the corresponding tool center path block by 90° or more or 270° or less.The check in this case can be disabled by setting CNC parameter No. 5008#1 to "1". (2) In the case of an arc, the difference in angle between the start and end points of the programmed block differs by 180° or more with the difference in angle between the start and end points of the corresponding tool center path block.
5405	ILLEGAL PARAMETER IN G41.2/G42.2	The parameter settings (parameter Nos. 19610 to 19619) for determining the relationship between the axis of rotation and the rotation plane are incorrect.

Number	Message	Contents
5406	G41.3/G40 FORMAT ERROR	<p>(1) A move instruction was specified in a block in which the G41.3 or G40 code is specified.</p> <p>(2) A G or M code which suppresses buffering was specified in the block in which the G41.3 code was specified.</p>
5407	ILLEGAL COMMAND IN G41.3	<p>(1) A G code other than G00 or G01 in group 01 was specified in the G41.3 mode.</p> <p>(2) An offset (G code in group 07) was specified in the G41.3 mode.</p> <p>(3) The block following the block in which G41.3 (startup) was specified did not contain a move command.</p>
5408	G41.3 ILLEGAL START_UP	<p>(1) The G41.3 G code (startup) was specified in a group 01 mode for other than G00 and G01.</p> <p>(2) The angle formed by the tool direction vector and the movement direction vector was 0° or 180° degrees at startup.</p>
5409	ILLEGAL PARAMETER IN G41.3	The parameter settings (parameter Nos. 19610 to 19619) for determining the relationship between the axis of rotation and the rotation plane are incorrect.
5196	ILLEGAL AXIS OPERATION	An attempt was made to use a function that cannot be used in the HPCC mode or when a function related to the five axes is being executed.

10.4.5 Tool Center Point Control (M series)

General

On a five-axis machine having two rotation axes that turn a tool, tool length compensation can be performed momentarily even in the middle of a block.

This tool length compensation is classified into one of two types based on the programming method. In the explanation of this function, the two rotation axes are assumed to be the B- and C-axes.

(1) Type 1

The rotation axis position (B, C) is specified.

The CNC applies tool length compensation according to the compensation amount along the tool axis whose orientation is calculated from the specified rotation axis position. This means that compensation is performed by moving the three linear axes.

(2) Type 2

The tool axis orientation (I, J, K) is specified.

The CNC controls the two rotation axes so that the tool is oriented as specified, and performs tool length compensation along the tool axis according to the compensation amount. This means that compensation is performed by moving the two rotation axes and three linear axes.

Tool center point control (type 1) differs from tool length compensation along the tool axis as shown below:

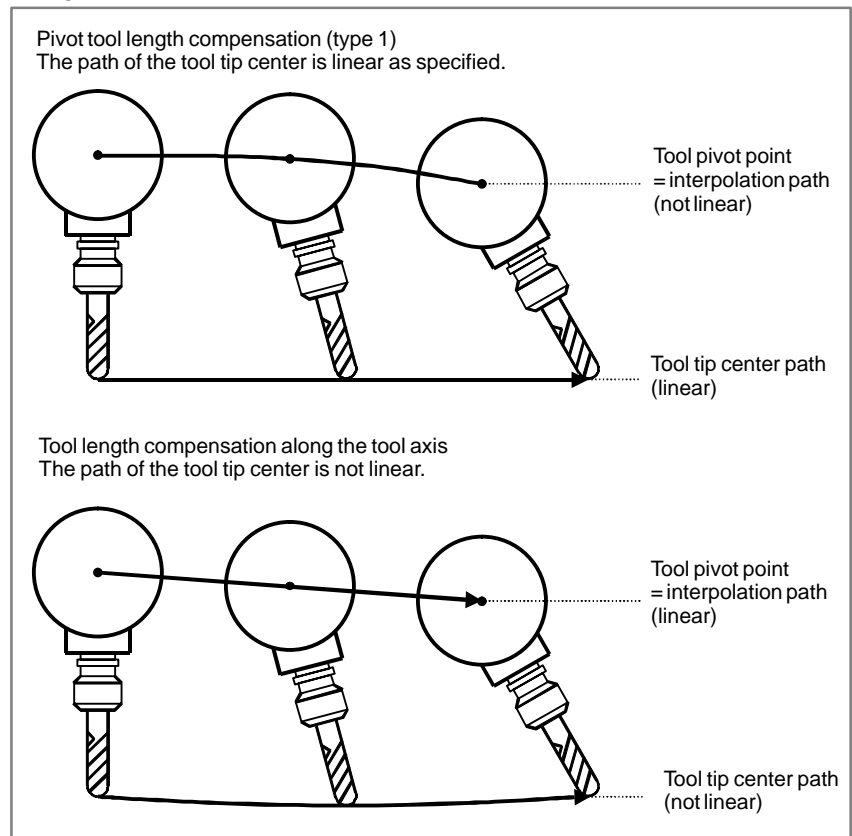

Fig. 10.4.5 Difference between Tool Center Point Control and Tool Length Compensation along the Tool Axis

NOTE

The length from the tool tip to tool pivot point must equal the sum of the tool length compensation amount and tool holder offset value.

RISC processor is necessary, if this function is used. Refer to Subsection 7.1.19 “RISC Processor Operation,” in this manual too.

Explanations

- **Specification of tool center point control**

The tool compensation vector changes in the following cases:

Type 1 : The offset value is changed, or the rotation axis position (B, C) is specified.

Type 2 : The offset value is changed, or the tool axis orientation (I, J, K) is specified.

As the tool compensation vector changes, movement is performed along the X-, Y-, and Z-axes by an amount equal to the change. The time at which the tool compensation vector is calculated is as follows:

Tool center point control : Calculated momentarily even in the middle of a block.

Tool length compensation along the tool axis : Calculated only at the end point of a block.

When only the rotation axis position is specified in tool center point control (type 1) mode, and when only I, J, and K are specified in tool center point control (type 2) mode, the tool tip center position remains unchanged before and after the specification. (Also, while the rotation axes are being moved, the tool tip center does not move.)

- **Inclination of the tool**

For tool center point control (type 2), the inclination angle of the tool can be specified with address Q of G43.5. The inclination angle of the tool is the difference in the angle between the tool orientation specified by (I, J, K) and the tool orientation set for actual machining.

If the tool orientation specified by (I, J, K) matches the tool orientation set for actual machining, Q need not be specified.

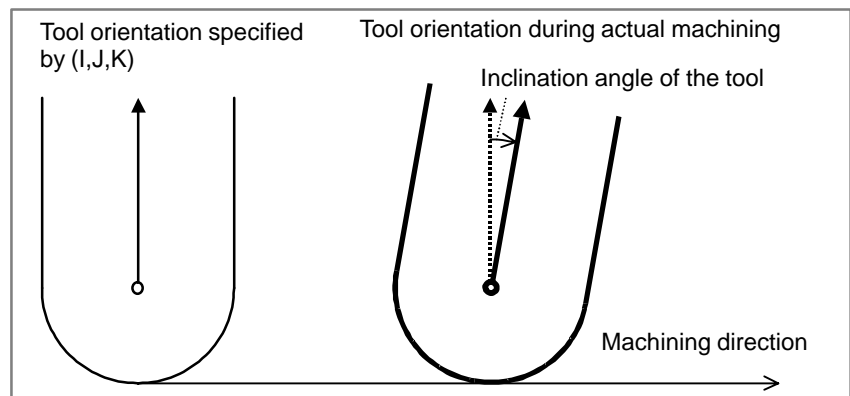

Example: For machining with the tool tilted toward the machining direction by 2 degrees, specify the following:

G43.5 I_ J_ K_ H_ Q2.0

● **Programmed point**

In programming, the position of the tool tip center is specified.

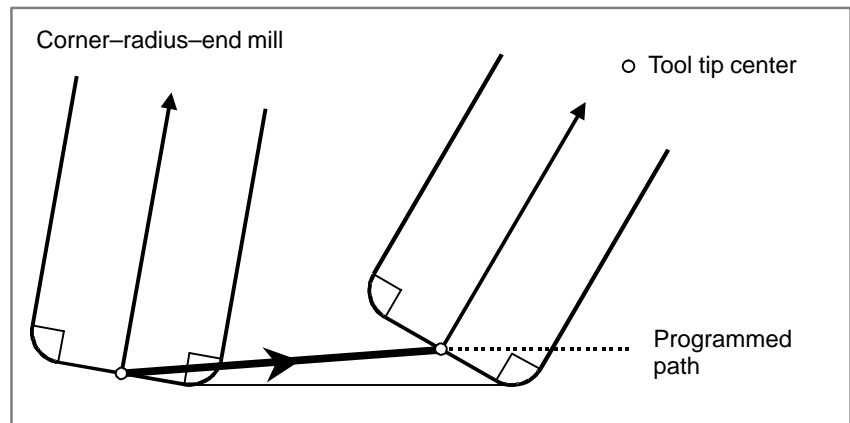
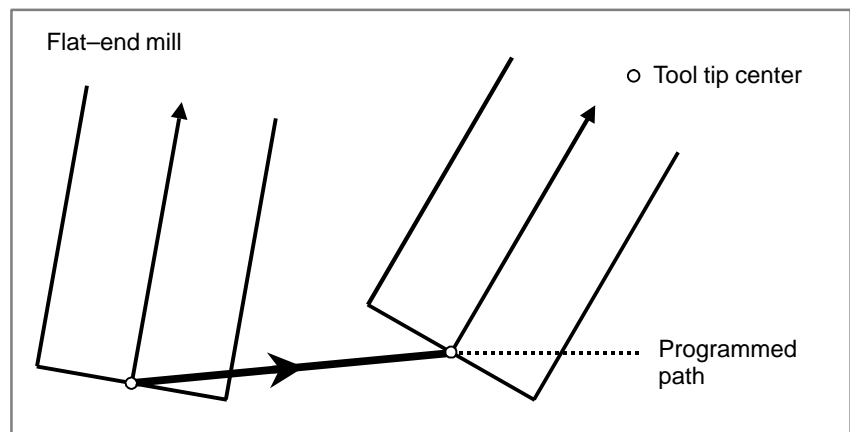
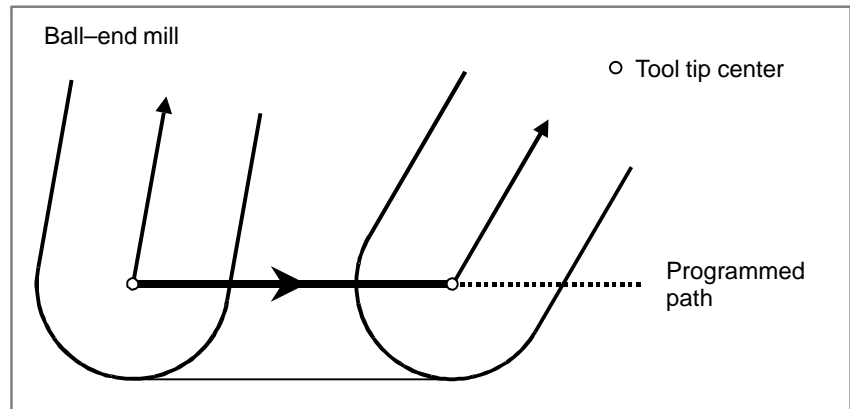

● **Linear interpolation (G01)**

When linear interpolation (G01) is specified in tool center point control mode, the feedrate is controlled so that the tool tip center moves at a specified feedrate.

Also, in tool center point control (type 2), the feedrate is controlled so that the tool tip center moves at a specified feedrate regardless of the setting of bit 2 (FWR) of parameter No. 7711.

- **Specification of rotation axes**

(1) Type 1

When only the rotation axes are specified in tool center point control (type 1) mode, the feedrate of the rotation axes is set to the maximum cutting feedrate (parameter No. 1422, No. 1430, or No. 1432).

(2) Type 2

In tool center point control (type 2) mode, the rotation axes cannot be specified. If the rotation axes are specified, alarm (PS5421) occurs.

- **Positioning (G00)**

NOTE

1 Set the following parameters:

(1) Bit 4 (LRP) of parameter No.1401 = 1: Linear-type rapid traverse

(2) Bit 5 (FRP) of parameter No.19501 = 1: Acceleration/deceleration before interpolation is used in rapid traverse.

(3) Parameter No.1620: Acceleration of acceleration/deceleration before interpolation for rapid traverse

(4) Parameter No.1622: Acceleration change period of bell-shaped acceleration/deceleration before interpolation for rapid travers

2 If the above settings are not made, or if look-ahead acceleration/deceleration before interpolation is not valid, axis movement may be performed at a higher feedrate than the rapid traverse rate.

- **Operation at start and cancellation**

(1) Type 1

When tool center point control (type 1) starts (G43.4H_) and when it is canceled (G49), the CNC calculates the compensation vector only at the end of the block.

(2) Type 2

When tool center point control (type 2) starts (G43.5H_) and when it is canceled (G49), the CNC calculates the compensation vector only at the end of the block.

- **Operation of tool center point control (type 1)**

The following items are the same as for tool length compensation along the tool axis:

- Machine configuration example and equation for rotation axis calculation
- Tool holder offset
- Specification of angular displacement in a parameter
- Zero-point compensation for the rotation axes
- Rotation axis offset

● **Operation of tool center point control (type 2)**

The following item is the same as for tool length compensation along the tool axis:

– Tool holder offset

Positioning (G00) and linear interpolation (G01) move the tool to the position (x, y, z, b, c) obtained by the following method simultaneously along the five axes.

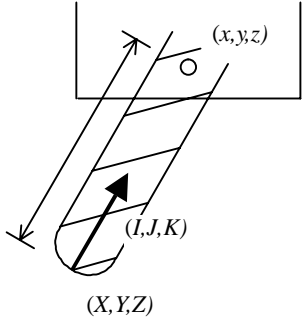

x,y,z : Tool center position
b,c : Rotation axis position
X,Y,Z : Tip position
 (programmed position)
I,J,K : Tool axis direction
l : Tool offset value

$$x = X + l \frac{I}{\sqrt{I^2 + J^2 + K^2}}$$

$$y = Y + l \frac{J}{\sqrt{I^2 + J^2 + K^2}}$$

$$z = Z + l \frac{K}{\sqrt{I^2 + J^2 + K^2}}$$

$$b = \tan^{-1} \frac{\sqrt{I^2 + J^2}}{K}$$

$$c = \tan^{-1} \frac{J}{I}$$

- **Example of machine configuration and expression for rotation axis calculation when tool center point control (type 2) is used**

(1) When the rotation axes are the A- and C-axes, and the tool axis is the Z-axis

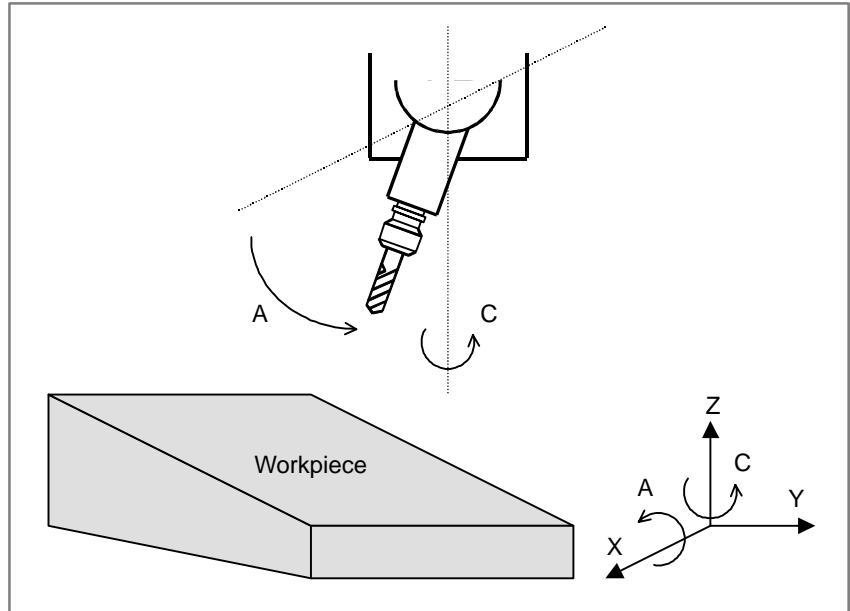

$$a = \tan^{-1} \frac{\sqrt{I^2 + J^2}}{K}$$

$$c = \tan^{-1} \frac{J}{I}$$

(2) When the rotation axes are the B- and C-axes, and the tool axis is the Z-axis

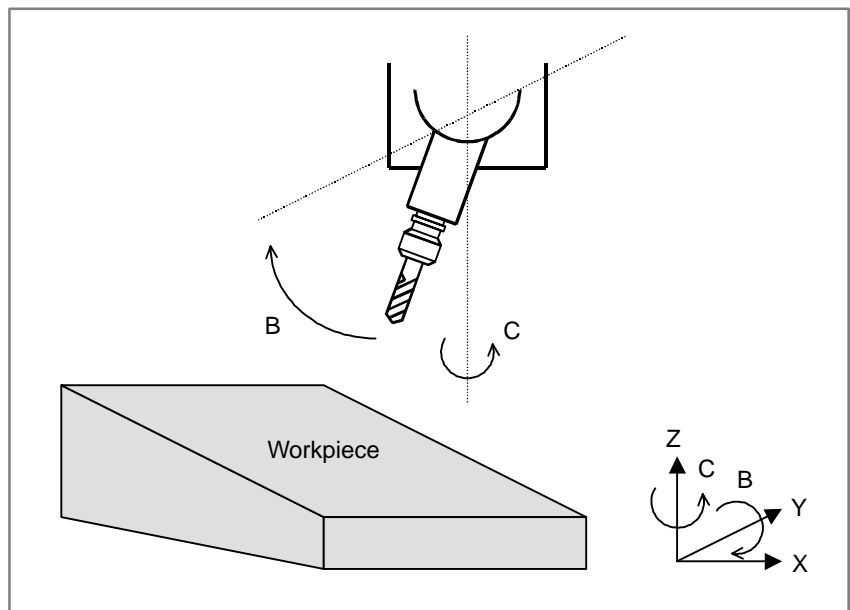

$$b = \tan^{-1} \frac{\sqrt{I^2 + J^2}}{K}$$

$$c = \tan^{-1} \frac{J}{I}$$

(3) When the rotation axes are the A- and B-axes, and the tool axis is the X-axis

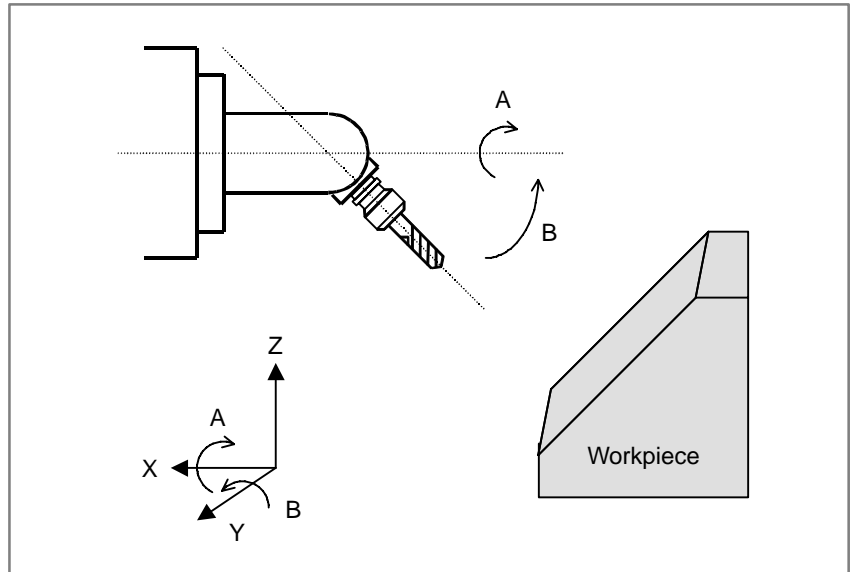

$$a = \tan^{-1} \frac{J}{-K}$$

$$b = \tan^{-1} \frac{\sqrt{J^2 + K^2}}{I}$$

(4) When the rotation axes are the A- and B-axes, and the tool axis is the Z-axis (master axis: B-axis)

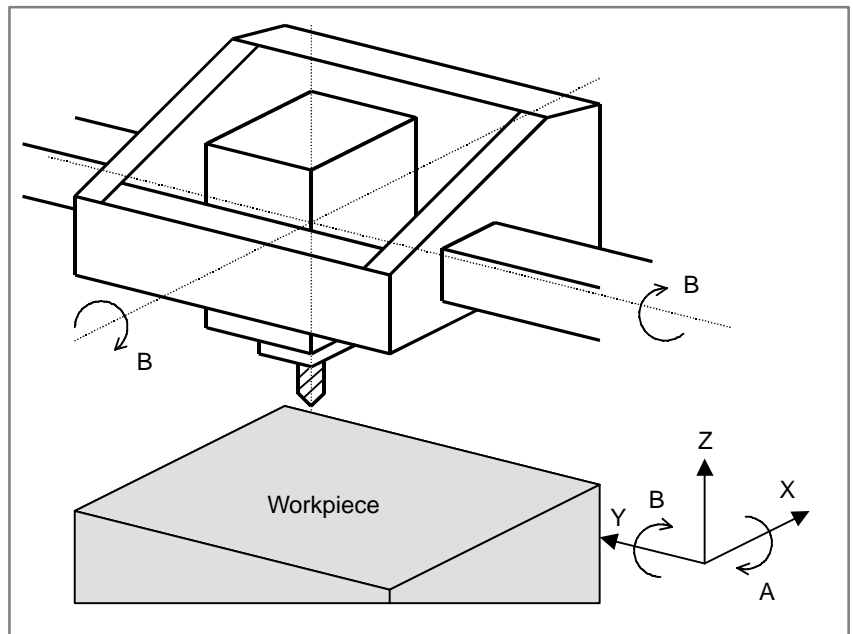

$$a = \tan^{-1} \frac{-J}{\sqrt{I^2 + K^2}}$$

$$b = \tan^{-1} \frac{I}{K}$$

(5) When the rotation axes are the A- and B-axes, and the tool axis is the Z-axis (master axis: A-axis)

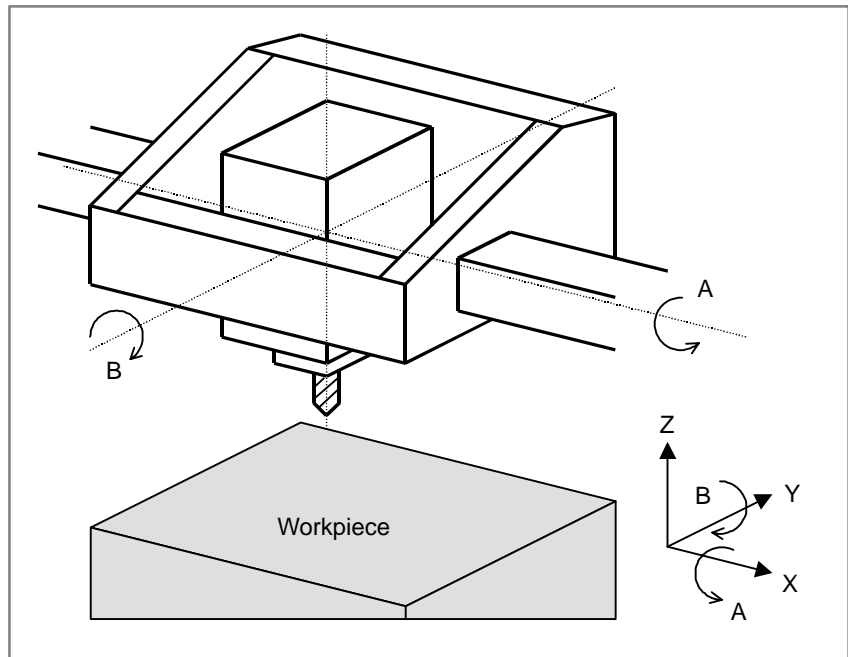

$$a = \tan^{-1} \frac{J}{K}$$

$$a = \tan^{-1} \frac{-J}{\sqrt{I^2 + K^2}}$$

- **Tool life management**

When tool life management is used, the tool length compensation amount of the tool used is used for tool center point control.

- **Three-dimensional cutter compensation**

Tool center point control and three-dimensional cutter compensation can be used at the same time.

Three-dimensional cutter compensation is applied to a specified tool tip point. Three-dimensional cutter compensation, however, is not performed momentarily in the middle of a block; it is performed only at the end of a block.

- **Three-dimensional coordinate conversion**

When tool center point control (type 2) is used during three-dimensional coordinate conversion, the tool axis orientation (I, J, K) is also subjected to three-dimensional coordinate conversion.

- **Rotation axis rollover**

NOTE

Whenever using tool center point control (type 2), set bit 2 (ROAx) of parameter No. 1008 to 1 to perform rotation axis rollover.

Parameter

	#7	#6	#5	#4	#3	#2	#1	#0
19650							RAP	RAM

[Input type] Parameter input

[Data type] Bit axis

RAM Specifies whether to use the axis as the rotation axis for tool axis direction tool length compensation.

0 : Not used as the rotation axis.

1 : Used as the rotation axis.

Select two axes from among rotation axes and set them as the rotation axes for these purposes.

RAP Specifies whether the rotation axis used for tool axis direction tool length compensation.

0 : Ordinary rotation axis.

1 : Parameter axis. The rotation axis is not controlled in designation direction tool length compensation.

If this bit is set to 0, absolute coordinates are used as the coordinates of rotation axes in tool axis direction tool length compensation mode, and machine coordinates are used in three-dimensional handle feed mode. If this bit is set to 1, the value set in parameter No. 19658 is used as the coordinates of the rotation axes.

When there is no rotation axis in the controlled axes, or when there is only one rotation axis in the controlled axes, set 1 in bit 0 (RAM) and bit 1 (RAP) of parameter No. 19650 for the linear axes to which non-existent rotation axes belong, and set an angular displacement in parameter No. 19658.

(Example 1)

There are linear axes X, Y, and Z, and rotation axes A, B, and C which rotate about the X-, Y-, and Z-axes, respectively. The tool axis direction is controlled with the rotation axes A and C.

	RAM (No. 19650#0)
X	0
Y	0
Z	0
A	1
B	0
C	1

(Example 2)

The controlled axes include only the linear axes X, Y, and Z. By using the tool attachment, the tool axis is tilted in the same tool axis direction as when the A- and C-axes are rotated.

	RAM (No. 19650#0)	RAP (No. 19650#1)	Angle (No. 19658)
X	1	1	45000
Y	0	0	0.0
Z	1	1	30000

19655

Axis number of the linear axis to which a rotation axis belongs

[Input type] Parameter input

[Data type] Word axis

[Valid data range] 0 – Number of controlled axes

When a rotation axis turns about a linear axis, the linear axis is referred to as an axis to which the rotation axis belongs, and is set using this parameter. For a rotation axis that belongs to no linear axis, or for a linear axis, 0 is set.

Example:

Axis configuration: X, Y, Z, C, A

Linear axis: X, Y, Z

Rotation axis: A (turning about the X-axis),
C (turning about the Z-axis)

In the above case, set the following:

Axis number	Axis name	Setting
1	X	0
2	Y	0
3	Z	0
4	C	3
5	A	1

19656

Tool axis direction

[Input type] Parameter input

[Data type] Word

[Valid data range] 1 – 3

Enter the tool axis direction when the two rotation axes are set at 0 degree.

Data	Tool axis direction
1	X-axis
2	Y-axis
3	Z-axis

19657	Master rotation axis number
-------	-----------------------------

[Input type] Parameter input

[Data type] Word

[Valid data range] 0 – Number of controlled axes

When a machine does not have the rotation axis that turns about the tool axis, the axis number of a rotation axis used as the master axis is set. For machines not using the master-axis configuration, 0 is set.

When the tool axis direction is controlled by two rotation axes, neither of which turns about the tool axis, one of the rotation axes is mounted on the other rotation axis as shown in the figure below. In this case, the rotation axis on which the other rotation axis is mounted is called the master axis.

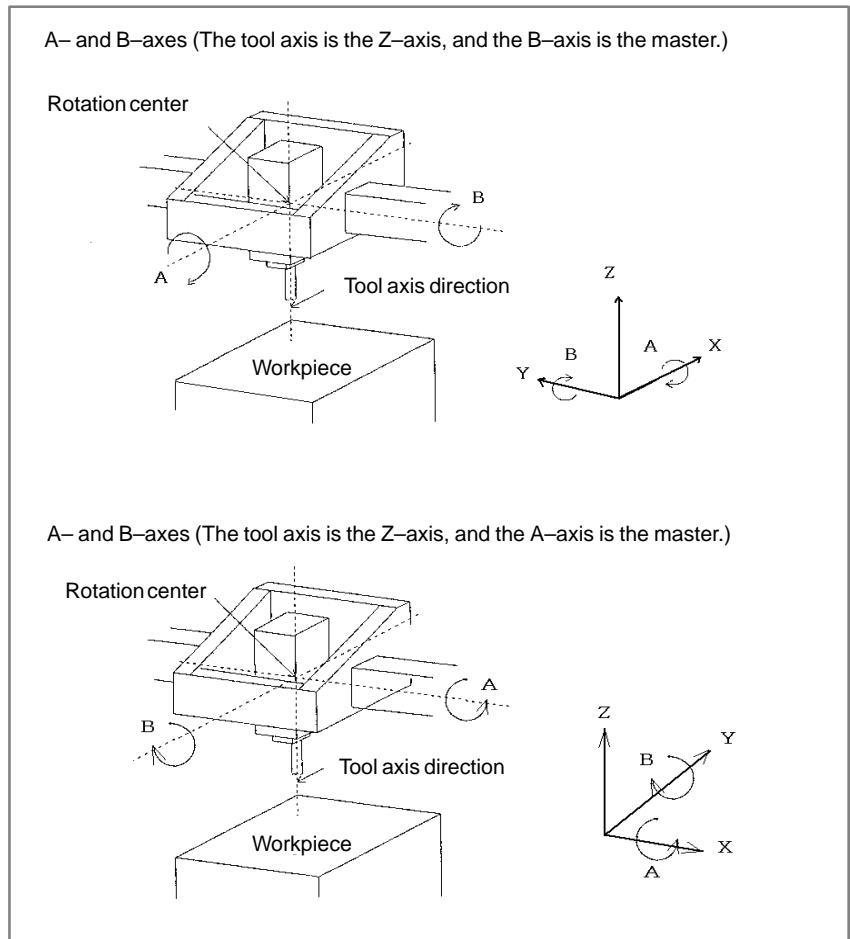

Example for setting parameters that determine the machine configuration

Tool axis direction: Z-axis

Axis configuration: X, Y, Z, W, A, B

Rotation axes: A-axis (axis rotating about the X-axis),

B-axis (axis rotating about the Y-axis)

Master axis: A-axis

Data No.	Data					
19655	X	Y	Z	W	A	B
	0	0	0	0	1	2
19656	3					
19657	5					

19658	Angular displacement of a rotation axis
-------	---

[Input type] Parameter input

[Data type] 2 word axis

[Unit of data] degree

Increment system	IS-A	IS-B	IS-C	Unit
Rotation axis	0.01	0.001	0.0001	deg

[Minimum unit of type] Depend on the increment system of the applied axis

[Valid data range] -99999999 to +99999999

When using the three-dimensional handle feed function or tool axis direction tool length compensation function, set the coordinate of a rotation axis, among the rotation axes determining the tool axis direction, which is not controlled by the CNC. This parameter is enabled or disabled, depending on the setting of bit 1 (RAP) of parameter No. 19650.

19659	Offset value for angular displacement of a rotation axis
-------	--

[Input type] Parameter input

[Data type] 2 word axis

[Unit of data] degree

Increment system	IS-A	IS-B	IS-C	Unit
Rotation axis	0.01	0.001	0.0001	deg

[Minimum unit of type] Depend on the increment system of the applied axis

[Valid data range] -99999999 to +99999999

An offset can be applied to the angular displacement of the three-dimensional handle feed function or tool axis direction tool length compensation function to compensate for the move direction.

19660	Origin offset value of a rotation axis
-------	--

[Input type] Parameter input

[Data type] 2 word axis

[Unit of data] degree

Increment system	IS-A	IS-B	IS-C	Unit
Rotation axis	0.01	0.001	0.0001	deg

[Minimum unit of type] Depend on the increment system of the applied axis

[Valid data range] -99999999 to +99999999

Set an angular displacement shifted from the origin for a rotation axis when the three-dimensional handle feed function or tool axis direction tool length compensation function is used.

19661	Rotation center compensation vector in tool length compensation along tool axis
-------	---

[Input type] Parameter input

[Data type] 2 word axis

[Unit of data] mm, inch (machine unit)

Increment system	IS-A	IS-B	IS-C	Unit
Millimeter machine	0.01	0.001	0.0001	mm
Inch machine	0.001	0.0001	0.00001	inch

[Minimum unit of type] Depend on the increment system of the applied axis

[Valid data range] -99999999 to +99999999

In the function for tool length compensation along the tool axis, set the vector from the first rotation axis center to second rotation axis center.

19662	Spindle center compensation vector in tool length compensation along tool axis
-------	--

[Input type] Parameter input

[Data type] 2 word axis

[Unit of data] mm, inch (machine unit)

Increment system	IS-A	IS-B	IS-C	Unit
Millimeter machine	0.01	0.001	0.0001	mm
Inch machine	0.001	0.0001	0.00001	inch

[Minimum unit of type] Depend on the increment system of the applied axis

[Valid data range] -99999999 to +99999999

In the function for tool length compensation along the tool axis, set the compensation vector of the spindle center.

	#7	#6	#5	#4	#3	#2	#1	#0
19665	ETH		SVC	SBP				

[Input type] Parameter input

[Data type] Bit

SBP In tool length compensation along the tool axis, shift of the control point is:

- 0 : Calculated automatically.
- 1 : Set in parameter No. 19667.

SVC In tool length compensation along the tool axis, the control point is:

- 0 : Not shifted.
- 1 : Shifted.

The shift method is specified with bit 4 (SBP) of parameter No. 19665.

ETH Specifies whether the tool holder offset function in tool axis direction tool length compensation is useful for the tool length compensation function.

- 0 : Not useful.
- 1 : Useful.

19666	Tool holder offset for tool axis direction tool length compensation
-------	---

[Input type] Parameter input

[Data type] 2 word

[Unit of data] mm, inch (machine unit)

Increment system	IS-A	IS-B	IS-C	Unit
Millimeter machine	0.01	0.001	0.0001	mm
Inch machine	0.001	0.0001	0.00001	inch

[Minimum unit of type] Depend on the increment system of the reference axis

[Valid data range] -99999999 to +99999999

Set an offset value (tool holder offset value) for the machine-specific portion from the rotation center of the rotation axis to the tool mounting position when the tool axis direction tool length compensation function is used.

Alarm and message

Number	Message	Contents
5425	ILLEGAL OFFSET VALUE	The offset number is incorrect.
5420	ILLEGAL PARAMETER IN G43.4/G43.5	A parameter related to tool center point control is incorrect.
5421	ILLEGAL COMMAND IN G43.4/G43.5	A command for a rotation axis was issued in the tool center point control (type 2) mode.
5422	EXCESS VELOCITY IN G43.4/G43.5	Tool center point control attempted to move the tool along an axis at a speed higher than the maximum permissible cutting feedrate for the axis.

Reference item

Connection manual (This function)	7.1.19	RISC Processor Operation
--------------------------------------	--------	--------------------------

11

PROGRAM COMMAND



11.1 DECIMAL POINT PROGRAMMING/ POCKET CALCULATOR TYPE DECIMAL POINT PROGRAMMING

General

Numerical values can be entered with a decimal point. A decimal point can be used when entering a distance, time, or speed. Decimal points can be specified with the following addresses:

X, Y, Z, U, V, W, A, B, C, I, J, K, Q, R, F M series
(for a type common to all axes)
X, Y, Z, U, V, W, A, B, C, I, J, K, R, F. T series

There are two types of decimal point notation: calculator-type notation and standard notation.

When calculator-type decimal point notation is used, a value without decimal point is considered to be specified in millimeters, inches or degree. When standard decimal point notation is used, such a value is considered to be specified in least input increments. Select either calculator-type or standard decimal point notation by using the DPI bit (bit 0 of parameter 3401). Setting the AXDx parameter (bit 0 of parameter No. 3455) to 1 (rather than using the M series) enables the calculator-type decimal input to be set up for individual axes separately. Values can be specified both with and without decimal point in a single program.

Program command	Pocket calculator type decimal point programming	Standard type decimal point programming
X1000 Command value without decimal point	1000mm Unit : mm	1mm Unit : Least input increment (0.001 mm)
X1000.0 Command value with decimal point	1000mm Unit : mm	1000mm Unit : mm

Parameter

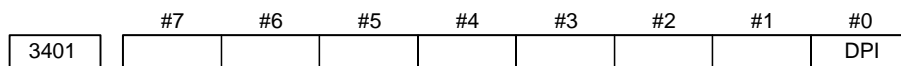

[Data type] Bit

DPI When a decimal point is omitted in an address that can include a decimal point

0 : The least input increment is assumed.

1 : The unit of mm, inches, degree, or s is assumed. (Pocket calculator type decimal point programming)

	#7	#6	#5	#4	#3	#2	#1	#0
3455								AXD

[Data type] Bit axis

AXD If a decimal point is omitted for an address with which a decimal point can be used, the value is determined:

0 : In accordance with the least input increment.

1 : In millimeters, inches, or seconds. (calculator-type decimal point input)

NOTE

- 1 This parameter is valid if bit 0 (DPI) of parameter No. 3401 is set to 0.
- 2 Because some addresses (such as R and K) are not related to an axis, setting this parameter for all axes is not equivalent to setting bit 0 (DPI) of parameter No. 3401 to 1.
- 3 This parameter cannot be used together with:
 - 1) High-speed remote buffer B
 - 2) Macro executor
 - 3) Basic operation package
 - 4) Macro call argument
 - 5) Tool length/workpiece zero point measurement B function
 - 6) Super CAPi M
 - 7) High-speed linear interpolation function
 - 8) Rotary table dynamic fixture offset function

Alarm and message

Number	Message	Description
007	ILLEGAL USE OF DECIMAL POINT	Decimal point “.” input error (A decimal point was input after an address with which it can not be used. Or multiple decimal points were input.) Modify the program.

Reference item

Series 16 <i>i</i> /18 <i>i</i> /160 <i>i</i> /180 <i>i</i> / 160 <i>is</i> /180 <i>is</i>	OPERATOR'S MANUAL (For Machining Center) (B-63534EN)	II.8.4	Decimal point programming
	OPERATOR'S MANUAL (For Lathe) (B-63524EN)	II.8.3	Decimal point programming
Series 21 <i>i</i> /210 <i>i</i> /210 <i>is</i>	OPERATOR'S MANUAL (For Machining Center) (B-63614EN)	II.8.4	Decimal point programming
	OPERATOR'S MANUAL (For Lathe) (B-63604EN)	II.8.3	Decimal point programming
Series 20 <i>i</i>	OPERATOR'S MANUAL (For Manual Milling Machine) (B-64204EN)	II.8.3	Decimal point programming
	OPERATOR'S MANUAL (For Manual Lathes) (B-64194EN)	II.8.3	Decimal point programming

11.2 G CODE SYSTEM (T SERIES)

General

There are three G code systems : A,B, and C (Table 11.2). Select a G code system using parameter GSC (No. 3401#7) and parameter GSB (No. 3401#6).

G code list for T series (1/3)

G code			Group	Function	
A	B	C			
G00	G00	G00	01	Positioning (Rapid traverse)	
G01	G01	G01		Linear interpolation (Cutting feed)	
G02	G02	G02		Circular interpolation CW	
G03	G03	G03		Circular interpolation CCW	
G04	G04	G04	00	Dwell	
G05	G05	G05		High speed cycle cutting, high-speed remote buffer A	
G07	G07	G07		Hypothetical axis interpolation	
G07.1 (G107)	G07.1 (G107)	G07.1 (G107)		Cylindrical interpolation	
G08	G08	G08		Advanced preview control	
G10	G10	G10		Programmable data input	
G10.6	G10.6	G10.6		Tool retract and return	
G11	G11	G11		Programmable data input mode cancel	
G12.1 (G112)	G12.1 (G112)	G12.1 (G112)		21	Polar coordinate interpolation mode
G13.1 (G113)	G13.1 (G113)	G13.1 (G113)			Polar coordinate interpolation cancel mode
G17	G17	G17	16	XpYp plane selection	
G18	G18	G18		ZpXp plane selection	
G19	G19	G19		YpZp plane selection	
G20	G20	G70	06	Input in inch	
G21	G21	G71		Input in mm	
G22	G22	G22	09	Stored stroke check function on	
G23	G23	G23		Stored stroke check function off	
G25	G25	G25	08	Spindle speed fluctuation detection off	
G26	G26	G26		Spindle speed fluctuation detection on	
G27	G27	G27	00	Reference position return check	
G28	G28	G28		Return to reference position	
G30	G30	G30		2nd, 3rd and 4th reference position return	
G30.1	G30.1	G30.1		Floating reference point return	
G31	G31	G31		Skip function	

G code list for T series (2/3)

G code			Group	Function
A	B	C		
G32	G33	G33	01	Thread cutting
G34	G34	G34		Variable-lead thread cutting
G35	G35	G35		Circular threading CW
G36	G36	G36		Circular threading CCW (When the bit 3 (G36) of parameter No. 3405 is set to 1)
G36	G36	G36	00	Automatic tool compensation X (When the bit 3 (G36) of parameter No. 3405 is set to 0)
G37	G37	G37		Automatic tool compensation Z
G37.1	G37.1	G37.1		Automatic tool compensation X
G37.2	G37.2	G37.2		Automatic tool compensation Z
G39	G39	G39		Corner circular interpolation
G40	G40	G40	07	Tool nose radius compensation cancel
G41	G41	G41		Tool nose radius compensation left
G42	G42	G42		Tool nose radius compensation right
G50	G92	G92	00	Coordinate system setting or max. spindle speed setting
G50.3	G92.1	G92.1		Workpiece coordinate system preset
G50.2 (G250)	G50.2 (G250)	G50.2 (G250)	20	Polygonal turning cancel
G51.2 (G251)	G51.2 (G251)	G51.2 (G251)		Polygonal turning
G52	G52	G52	00	Local coordinate system setting
G53	G53	G53		Machine coordinate system setting
G54	G54	G54	14	Workpiece coordinate system 1 selection
G55	G55	G55		Workpiece coordinate system 2 selection
G56	G56	G56		Workpiece coordinate system 3 selection
G57	G57	G57		Workpiece coordinate system 4 selection
G58	G58	G58		Workpiece coordinate system 5 selection
G59	G59	G59		Workpiece coordinate system 6 selection
G60	G60	G60	00	Single direction positioning
G65	G65	G65		Macro calling
G66	G66	G66	12	Macro modal call
G67	G67	G67		Macro modal call cancel
G68	G68	G68	04	Mirror image for double turrets ON or balance cut mode
G68.1	G68.1	G68.1	17	Three-dimensional coordinate system conversion mode on
G69	G69	G69	04	Mirror image for double turrets OFF or balance cut mode cancel
G69.1	G69.1	G69.1	17	Three-dimensional coordinate system conversion mode off

G code list for T series (3/3)

G code			Group	Function
A	B	C		
G70	G70	G72	00	Finishing cycle
G71	G71	G73		Stock removal in turning
G72	G72	G74		Stock removal in facing
G73	G73	G75		Pattern repeating
G74	G74	G76		End face peck drilling
G75	G75	G77		Outer diameter/internal diameter drilling
G76	G76	G78		Multiple threading cycle
G71	G71	G72	01	Traverse grinding cycle (for grinding machine)
G72	G72	G73		Traverse direct constant-dimension grinding cycle (for grinding machine)
G73	G73	G74		Oscillation grinding cycle (for grinding machine)
G74	G74	G75		Oscillation direct constant-dimension grinding cycle (for grinding machine)
G80	G80	G80	10	Canned cycle for drilling cancel
G83	G83	G83		Cycle for face drilling
G84	G84	G84		Cycle for face tapping
G86	G86	G86		Cycle for face boring
G87	G87	G87		Cycle for side drilling
G88	G88	G88		Cycle for side tapping
G89	G89	G89		Cycle for side boring
G90	G77	G20	01	Outer diameter/internal diameter cutting cycle
G92	G78	G21		Thread cutting cycle
G94	G79	G24		Endface turning cycle
G96	G96	G96	02	Constant surface speed control
G97	G97	G97		Constant surface speed control cancel
G98	G94	G94	05	Per minute feed
G99	G95	G95		Per rotation feed
-	G90	G90	03	Absolute programming
-	G91	G91		Incremental programming
-	G98	G98	11	Return to initial level
-	G99	G99		Return to R point level
G100	G100	G100	00	B axis control-Program registration completion
G101	G101	G101		B axis control-First program registration start
G102	G102	G102		B axis control-Second program registration start
G103	G103	G103		B axis control-Third program registration start
G110	G110	G110		B axis control-One motion operation programming

Parameter

	#7	#6	#5	#4	#3	#2	#1	#0
3401	GSC	GSB						

[Data type] Bit**GSB, GSC** The G code system is set.

GSC	GSB	G code
0	0	G code system A
0	1	G code system B
1	0	G code system C

	#7	#6	#5	#4	#3	#2	#1	#0
3402		CLR			G91			G01

[Data type] Bit**G01** Mode entered when the power is turned on or when the control is cleared

0 : G00 mode (positioning)

1 : G01 mode (linear interpolation)

G91 When the power is turned on or when the control is cleared

0 : G90 mode (absolute command)

1 : G91 mode (incremental command)

CLR Reset button on the CRT/MDI panel, external reset signal, reset and rewind signal and emergency stop signal

0 : Cause reset state.

1 : Cause clear state.

Alarm and message

Number	Message	Description
010	IMPROPER G-CODE	An unusable G code or G code corresponding to the function not provided is specified. Modify the program.

Note**NOTE**

- 1 If the CNC enters the clear state (see bit 6 (CLR) of parameter 3402) when the power is turned on or the CNC is reset, the modal G codes change as follows.
 - (1) G codes marked with  in Table 11.2 are enabled.
 - (2) When the system is cleared due to power-on or reset, whichever specified, either G20 or G21, remains effective.
 - (3) Bit 7 (G23) of parameter No. 3402 is used to specify whether G22 or G23 is to be selected upon power-on. The selection of G22 or G23 is not, however, changed when the CNC is cleared upon a reset.
When the system is cleared due to reset, whichever specified, either G22 or G23, remains effective.
 - (4) Setting bit 0 (G01) of parameter 3402 determines which code, either G00 or G01, is effective.
 - (5) Setting bit 3 (G91) of parameter 3402 determines which code, either G90 or G91, is effective.
- 2 G codes of group 00 except G10 and G11 are single-shot G codes.
- 3 Alarm 010 is displayed when a G code not listed in the G code list is specified or a G code without a corresponding option is specified.
- 4 G codes of different groups can be specified in the same block.
If G codes of the same group are specified in the same block, the G code specified last is valid.
- 5 If a G code of group 01 is specified in a canned cycle, the canned cycle is canceled in the same way as when a G80 command is specified. G codes of group 01 are not affected by G codes for specifying a canned cycle.
- 6 When G code system A is used for a canned cycle, only the initial level is provided at the return point.
- 7 G codes are displayed for each group number.

Reference item

Series 16 <i>i</i> /18 <i>i</i> /160 <i>i</i> /180 <i>i</i> / 160 <i>is</i> /180 <i>is</i>	OPERATOR'S MANUAL (For Lathe) (B-63524EN)	II.3	PREPARATORY FUNCTION (G FUNCTION)
		APPENDIX E	STATUS WHEN TURNING POWER ON, WHEN CLEAR AND WHEN RESET
Series 21 <i>i</i> /210 <i>i</i> /210 <i>is</i>	OPERATOR'S MANUAL (For Lathe) (B-63604EN)	II.3	PREPARATORY FUNCTION (G FUNCTION)
		APPENDIX E	STATUS WHEN TURNING POWER ON, WHEN CLEAR AND WHEN RESET
Series 20 <i>i</i>	OPERATOR'S MANUAL (For Manual Milling Machine) (B-64204EN)	II.3	PREPARATORY FUNCTION (G FUNCTION)
		APPENDIX E	STATUS WHEN TURNING POWER ON, WHEN CLEAR AND WHEN RESET
	OPERATOR'S MANUAL (For Manual Lathes) (B-64194EN)	II.3	PREPARATORY FUNCTION (G FUNCTION)
		APPENDIX E	STATUS WHEN TURNING POWER ON, WHEN CLEAR AND WHEN RESET

11.3 PROGRAM CONFIGURATION

General

A program consists of the following components:

Table 11.3 Program components

Components	Descriptions
Tape start	Symbol indicating the start of a program file
Leader section	Used for the title of a program file, etc.
Program start	Symbol indicating the start of a program
Program section	Commands for machining
Comment section	Comments or directions for the operator
Tape end	Symbol indicating the end of a program file

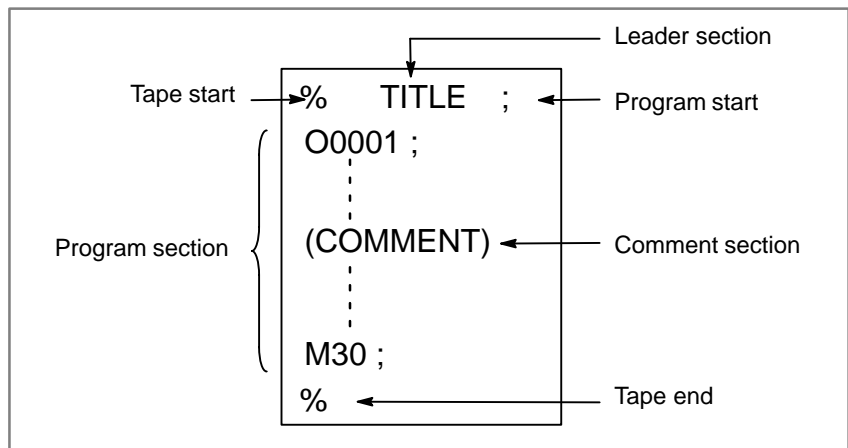
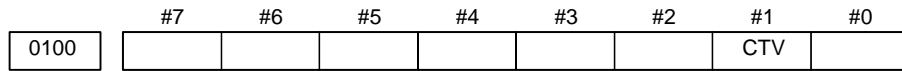

Fig. 11.3 Program configuration

Parameter



Setting entry is acceptable.

[Data type] Bit

CTV: Character counting for TV check in the comment section of a program.
 0 : Not performed
 1 : Performed

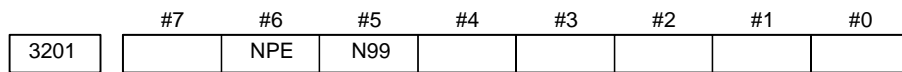

[Data type] Bit

N99 With an M99 block, when bit 6 (NPE) of parameter No. 3201 = 0, program registration is assumed to be:
 0 : Completed
 1 : Not completed

NPE With an M02, M30, or M99 block, program registration is assumed to be:
 0 : Completed
 1 : Not completed

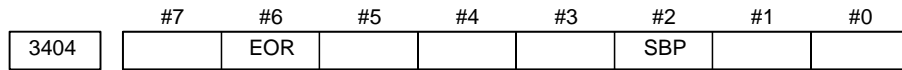

[Data type] Bit

SBP Address P of the block including M198 in the subprogram call function
 0 : Indicating a file number
 1 : Indicating a program number

EOR When the end-of-record mark (%) is read during program execution:
 0 : P/S alarm No. 5010 occurs.
 (Automatic operation is stopped, and the system enters the alarm state.)
 1 : No alarm occurs.
 (Automatic operation is stopped, and the system is reset.)

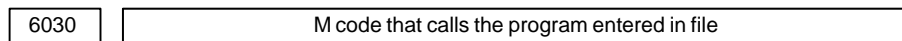

[Data type] Byte

[Valid data range] 0, and 1 to 255
 When the subprogram call function is used, this parameter sets the M code for calling a program in a file stored on the external input/output device.

NOTE
 The M code is judged to be M198 when zero is specified as the setting value.

Alarm and message

Number	Message	Description
001	TH PARITY ALARM	TH alarm (A character with incorrect parity was input).
002	TV PARITY ALARM	TV alarm (The number of characters in a block is odd). This alarm will be generated only when the TV check is effective (when TVC, bit 0 of setting parameter 0000 is set to 1).
5010	END OF RECORD	The end of record (%) was specified.

Reference item

Series 16i/18i/160i/180i/ 160is/180is	OPERATOR'S MANUAL (For Machining Center) (B-63534EN)	II.12	Program Configuration
	OPERATOR'S MANUAL (For Lathe) (B-63524EN)	II.12	Program Configuration
Series 21i/210i/210is	OPERATOR'S MANUAL (For Machining Center) (B-63614EN)	II.12	Program Configuration
	OPERATOR'S MANUAL (For Lathe) (B-63604EN)	II.12	Program Configuration
Series 20i	OPERATOR'S MANUAL (For Manual Milling Machine) (B-64204EN)	II.12	Program Configuration
	OPERATOR'S MANUAL (For Manual Lathes) (B-64194EN)	II.12	Program Configuration

11.4 INCH/METRIC CONVERSION

General

Either inch or metric input can be selected by G code.

Signal

**Inch input signal
INCH<F002#0>**

[Classification] Output signal

[Function] This signal indicates that inch input mode is active.

[Output condition] “1” indicates that the inch input mode (G20) is in progress, and “0” indicates that metric input mode (G21) is in progress.

This signal changes to the corresponding state when modes are switched using the setting data display on the MDI panel.

Signal address

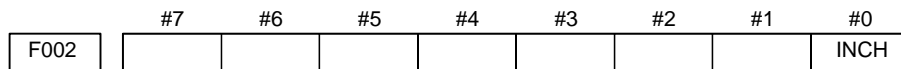

Parameter



Setting entry is acceptable.

[Data type] Bit

INI Unit of input

0: In mm

1: In inches

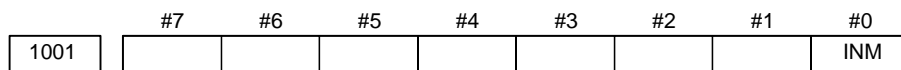

NOTE

When this parameter is set, the power must be turned off before operation is continued.

[Data type] Bit

INM Least command increment on the linear axis

0 : In mm (metric system machine)

1 : In inches (inch system machine)

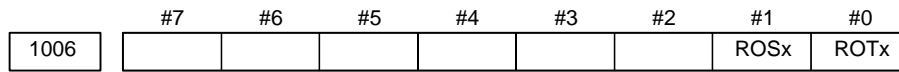

NOTE
When this parameter is changed, turn off the power before continuing operation.

[Data type] Bit axis

ROTx, ROSx Setting linear or rotation axis

ROSx	ROTx	Description
0	0	Linear axis · Inch/metric conversion is done. · All coordinate values are linear axis type. (Not rounded in 0 to 360°) · Stored pitch error compensation is linear axis type (Refer to parameter No. 3624)
0	1	Rotation axis (A type) · Inch/metric conversion is not done. · Machine coordinate values are rounded in 0 to 360° Rounding of absolute coordinate values and relative coordinate values is decided by parameter No. 1008#0 and #2. · Stored pitch error compensation is of the rotation type. (Refer to parameter No. 3624) · Automatic reference position return (G28, G30) is done in the reference position return direction and the move amount does not exceed one rotation.
1	0	Setting is invalid (unused)
1	1	Rotation axis (B type) · Inch/metric conversion is not done. · Machine coordinate values is of linear axis type (i.e. not rounded in 0 to 360°). · Rounding of absolute coordinate values and relative coordinate values is decided by parameter No. 1008#0 and #2. · Stored pitch error compensation is of linear axis type (Refer to parameter No. 3624). · Cannot be used with the rotation axes roll over function and the index table indexing function (M series).

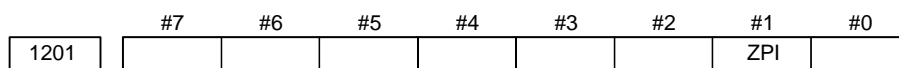

[Data type] Bit

ZPI Coordinates at the reference position when a coordinate system is set automatically

0 : Value set in parameter No. 1250 is used.

1 : For input in mm, the value set in parameter 1250 is used, or for input in inches, the value set in parameter No. 1251 is used.

1250	Coordinate value of the reference position used when automatic coordinate system setting is performed
------	---

[Data type] Two-word axis

[Unit of data]	Increment system	IS-A	IS-B	IS-C	Unit
	Linear axis (Metric input)	0.01	0.001	0.0001	mm
	Linear axis (Inch input)	0.001	0.0001	0.00001	inch
	Rotation axis	0.01	0.001	0.0001	deg

[Valid data range] – 99999999 to 99999999

Set the coordinate value of the reference position on each axis used for setting a coordinate system automatically.

1251	Coordinate value of the reference position on each axis used for setting a coordinate system automatically when input is performed in inches
------	--

[Data type] Two-word axis

[Unit of data]	Increment system	IS-A	IS-B	IS-C	Unit
	Inch input	0.001	0.0001	0.00001	inch

[Valid data range] – 99999999 to 99999999

Set the coordinate value of the reference position on each axis used for setting a coordinate system automatically when input is performed in inches.

NOTE
This parameter is valid when ZPI in parameter 1201#1 is set to 1.

1403	#7	#6	#5	#4	#3	#2	#1	#0
								MIF

[Data type] Bit

- MIF** Cutting feedrates at feed per minute is specified by F commands
- 0 : In units of 1 mm/min for millimeter machines or 0.01 inches/min for inch machines.
 - 1 : In unit of 0.001 mm/min for millimeter machines or 0.00001 inches/min for inch machines.

NOTE
M series are not equipped with this parameter. Cutting feedrates are specified by F commands in units of 0.001 mm/min for millimeter machines or 0.00001 inches/min for inch machines.

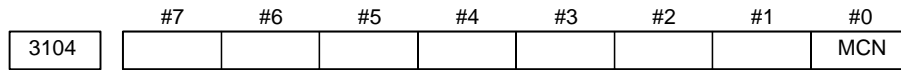

[Data type] Bit

MCN Machine position is:

- 0 : Not displayed according to the unit of input.
(Regardless of whether input is made in mm or inches, the machine position is displayed in mm for millimeter machines, or in inches for inch machines.)
- 1 : Displayed according to the unit of input.
(When input is made in mm, the machine position is displayed in mm, and when input is made in inches, the machine position is displayed in inches accordingly.)

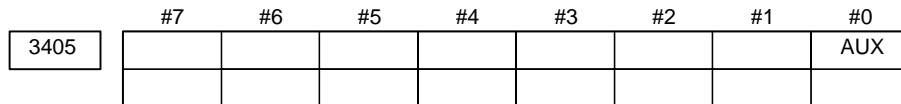

[Data type] Bit

AUX The least increment of the command of the second miscellaneous function specified with a decimal point

- 0 : Assumed to be 0.001
- 1 : Depending on the input increment.
(For input in mm, 0.001 is assumed, or for input in inches, 0.0001 is assumed.)

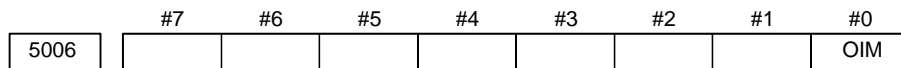

[Data type] Bit

OIM When the unit is switched between the inch and metric systems, automatic tool compensation value conversion is:

- 0 : Not performed
- 1 : Performed

NOTE

If you change this parameter, re-set the tool compensation data.

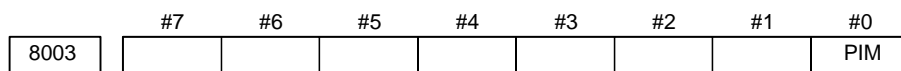

[Data type] Bit

PIM When only the axes controlled by the PMC are used, the linear axis is:

- 0 : Influenced by inch/millimeter input.
- 1 : Not influenced by inch/millimeter input.

Warning**WARNING**

When switching inch input (G20) to metric input (G21) and vice versa, the tool compensation value must be re-set according to the least input increment.

However, when bit 0 (OIM) of parameter 5006 is 1, tool compensation values are automatically converted and need not be re-set.

Note**NOTE**

- 1 When the least input increment and the least command increment systems are different, the maximum error is half of the least command increment. This error is not accumulated.
- 2 Reference position return is performed at a low speed for the first G28 command after the inch input is switched to the metric input or vice versa.
- 3 The inch and metric input can also be switched using parameter (No. 0000#2).

Reference item

Series 16i/18i/160i/180i/ 160is/180is	OPERATOR'S MANUAL (For Machining Center) (B-63534EN)	II.8.3	Inch/metric conversion (G20, G21)
	OPERATOR'S MANUAL (For Lathe) (B-63524EN)	II.8.2	Inch/metric conversion (G20, G21)
Series 21i/210i/210is	OPERATOR'S MANUAL (For Machining Center) (B-63614EN)	II.8.3	Inch/metric conversion (G20, G21)
	OPERATOR'S MANUAL (For Lathe) (B-63604EN)	II.8.2	Inch/metric conversion (G20, G21)
Series 20i	OPERATOR'S MANUAL (For Manual Milling Machine) (B-64204EN)	II.8.2	Inch/metric conversion (G20, G21)
	OPERATOR'S MANUAL (For Manual Lathes) (B-64194EN)	II.8.2	Inch/metric conversion (G20, G21)

11.5 HIGH SPEED CYCLE CUTTING

General

This function can convert the machining profile to a data group that can be distributed as pulses at high-speed by the macro compiler and macro executor. The function can also call and execute the data group as a machining cycle using the CNC command (G05 command).

NOTE

This function cannot be used for two-path control.

• Format

G05 P10○○○ L○○○ ;

P10○○○ is number of the cutting cycle to be called first:

P10001 to P10999

L○○○ is repetition count of the cutting cycle

(L1 applies when this parameter is omitted.) :

L1 to L999

Call and execute the data for the high speed cutting cycle specified by the macro compiler and macro executor using the above command.

Cycle data can be prepared for up to 999 cycles. Select the machining cycle by address P. More than one cycle can be called and executed in series using the cycle connection data in the header.

Specify the repetition count of the called machining cycle by address L. The repetition count in the header can be specified for each cycle.

The connection of cycles and their repetition count are explained below with an example.

Example) Assume the following:

Cycle 1 Cycle connection data 2 Repetition count 1

Cycle 2 Cycle connection data 3 Repetition count 3

Cycle 3 Cycle connection data 0 Repetition count 1

G05 P10001 L2 ;

The following cycles are executed in sequence:

Cycles 1, 2, 2, 2, 3, 1, 2, 2, 2, and 3

• Number of control axes

Six axes maximum can be controlled. Six axes can be controlled simultaneously.

• Pulse distribution

Set the number of pulses per cycle in parameter 7501#4 to #6 as a macro variable for high speed cycle cutting using the macro compiler and macro executor.

The unit for the number of pulses is the least input increment.

● **Configuration of high-speed cycle cutting data**

Data for the high speed cycle cutting is assigned to variables (#20000 to #85535) for the high-speed cycle cutting by the macro compiler and macro executor.

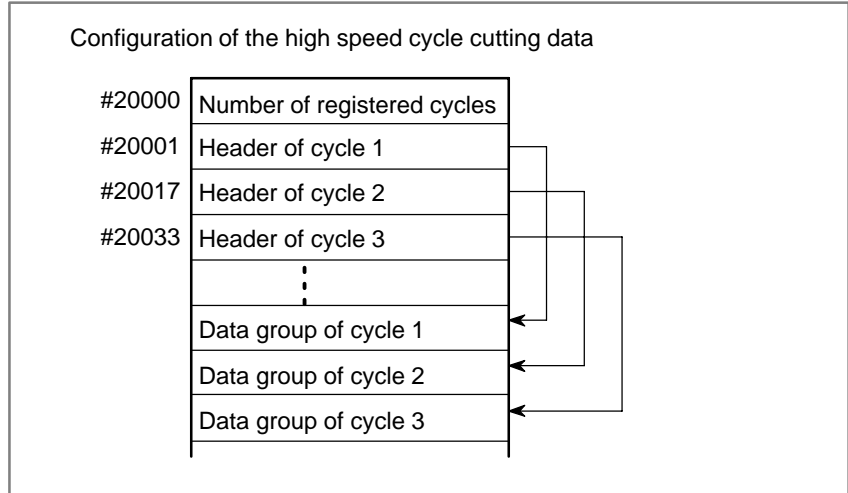

● **High-speed cycle cutting data variable addition A (T series)**
High-speed cycle cutting data variable addition B (T series)

Using "high-speed cycle cutting data variable addition A" or "high-speed cycle cutting data variable addition B" enables the number of data items (number of P-CODE variables) used for high-speed cycle cutting to be increased as listed in the following table (T series only).

	Number of high-speed cycle cutting variables
High-speed cycle cutting	#20000 to #85535
High-speed cycle cutting data variable addition A	#200000 to #331071
High-speed cycle cutting data variable addition B	#200000 to #462143

NOTE

- Both "high-speed cycle cutting data variable addition A" and "high-speed cycle cutting data variable addition B" are options.
- Using these functions requires the "high-speed cycle cutting" option.
- When these functions are in use, it is impossible to use high-speed cycle cutting variables #20000 to #85535.

● **Number of Registered Cycles**

Specify the number of cycles (number of headers) of high-speed cycle cutting data. Values from 1 to 999 can be specified.

- **Header**

The header for high-speed cycle cutting data has the following configuration:

Header configuration	
#20001/20017/20033..	Cycle repetition count
#20002/20018/20034..	Cycle connection data
#20003/20019/20035..	Number of data items
#20004/20020/20036..	Data type
#20005/20021/20037..	Variable assigned to the 1st axis data
#20006/20022/20038..	Variable assigned to the 2nd axis data
#20007/20023/20039..	Variable assigned to the 3rd axis data
#20008/20024/20040..	Variable assigned to the 4th axis data
#20009/20025/20041..	Variable assigned to the 5th axis data
#20010/20026/20042..	Variable assigned to the 6th axis data
#20011/20027/20043..	Total number of fixed data items for the 1st axis
#20012/20028/20044..	Total number of fixed data items for the 2nd axis
#20013/20029/20045..	Total number of fixed data items for the 3rd axis
#20014/20030/20046..	Total number of fixed data items for the 4th axis
#20015/20031/20047..	Total number of fixed data items for the 5th axis
#20016/20032/20048..	Total number of fixed data items for the 6th axis

Explanations

- **Cycle repetition count**
- **Cycle connection data**
- **Number of data items**

Specify the repetition count for the cycle. Values from 0 to 32767 can be specified. When 0 or 1 is specified, the cycle is executed once.

Specify the number (1 to 999) of the cycle to be executed after the cycle. When no connection cycle exists because of the last cycle, specify 0.

Specify the number of data items per cycle. Valid values are from 1 to 32767.

When a fixed data item is specified, the fixed data is repeated for the specified number of times in one cycle.

- **Data type**

15	14	13	12	11	10	9	8	7	6	5	4	3	2	1	0
-	-	r6	r5	r4	r3	r2	r1	-	-	t6	t5	t4	t3	t2	t1

The bits from t1 to t6, corresponding to the 1st to 6th axes, have the following meanings:

0: Distribution data is always constant.

1: Distribution data is variable or fixed.

When the distribution data is variable or fixed, the bits from r1 to r6, corresponding to the 1st to 6th axes, have the following meanings:

0: Distribution data is read forward.

1: Distribution data is read backwards.

Because the data consists of bits, it is necessary to use a binary-coded decimal value when setting it using the macro compiler and macro executor.

Example)

When constant data is assigned to the 1st and 2nd axes and variable data is assigned to the 3rd and 4th axes, #20004 = 12; (t4 and t3: 1, t2 and t1: 0)

- **Variables assigned to data for the 1st to 6th axes**

· **Constant data**

When the corresponding data type bit (t6 to t1) is 0, specify “distribution data value”.

· **Variable data**

When the corresponding data type bit (t6 to t1) is 1 and the total number of fixed data items = 0, specify “(Storing start data variable No. of the distribution data)/10”.

· **Fixed data**

When the corresponding data type bit (t6 to t1) is 1 and the total number of fixed data items is other than 0, specify “(Storing start data variable No. of the distribution data)/10”.

The applicable value for the variable data and fixed data is 2001 to 8553. It is not possible to start storing data in the executable format from a variable No. that is not a multiple of 10.

To read the distribution data backwards, set the variable No. of the data to be distributed last. For example, to read the distribution data in #25000 to #25999 backwards, set 25000 as the data assignment variable.

- **Total number of fixed data items for the first to 6th axes**

Set the length of the fixed data for the cycle.

The first address of the fixed data must be specified by the data assignment variable. When the total number of fixed data items = 0 and the corresponding data type bit (t6 to t1) is 1, the data is regarded as a variable data.

Parameter

	#7	#6	#5	#4	#3	#2	#1	#0
7501	IPC	IT2	IT1	IT0				CSP
	IPC	IT2	IT1	IT0				

[Data type] Bit

CSP Cs contouring control function dedicated to a piston lathe is
 0 : Not used.
 1 : Used.

IT0, IT1, IT2

IT2	IT1	IT0	
0	0	0	Interpolates the G05 data in 8ms
0	0	1	Interpolates the G05 data in 2ms
0	1	0	Interpolates the G05 data in 4ms
0	1	1	Interpolates the G05 data in 1ms
1	0	0	Interpolates the G05 data in 16ms

IPC 0 : The system does not monitor whether a distribution process is stopped while high-speed cutting (G05) is performed with high-speed remote buffer A or B or in a high-speed cycle cutting.
 1 : The system monitors whether a distribution process is stopped while high-speed machining (G05) is performed with high-speed remote buffer A or B or in a high-speed cycle cutting.
 (Alarms 179 and 000 are simultaneously issued if the distribution process is stopped. In this case, the power must be turned off then on again.)

NOTE

The distribution process stops, when the host cannot send data with the high-speed remote buffer by the specified time.

	#7	#6	#5	#4	#3	#2	#1	#0
7505							HUNx	HSCx
								HSCx

NOTE

After setting this parameter, the power must be turned off then on again.

[Data type] Bit axis

HSCx Specifies whether each axis is used for high-speed distribution in a high-speed cycle cutting or with a high-speed remote buffer.
 0 : Not used for high-speed distribution
 1 : Used for high-speed distribution

HUNx Specifies whether the unit of data to be distributed during cutting in a high-speed cycle is ten times the least input increment.

0 : The unit of data is the same as the least input increment.

1 : The unit of data is ten times the least input increment.

NOTE

This parameter is used when a data item to be distributed exceeds a word in terms of the least input increment or the maximum travel speed.

CNC distributes ten times the value for cutting in a high-speed cycle for the axes in which HUNx of this parameter is set to 1. Therefore, set a value one tenth the value to be distributed for cutting in a high-speed cycle along the specified axes.

7510

Maximum number of simultaneously controlled axes when G05 is specified during high-speed cycle cutting or No. of controlled axes in high-speed remote buffer

[Data type] Word

[Unit of data] 1 to 6

This parameter sets the maximum number of simultaneous control axes when G05 is specified during high-speed cycle cutting or sets the number of control axes in a high-speed remote buffer.

Alarm and message

Number	Message	Description
115	ILLEGAL VARIABLE NUMBER	<p>The header contents are improper in a high-speed cycle cutting. This alarm is given in the following cases:</p> <ol style="list-style-type: none"> 1. The header corresponding to the specified cutting cycle number called is not found. 2. The cycle connection data value is out of the allowable range (0 – 999). 3. The number of data in the header is out of the allowable range (0 – 32767). 4. The storing start data variable number of executable format data is out of the allowable range (#20000 – #85535). 5. The storing data variable number of executable format data is out of the allowable range (#85535). 6. The storing start data variable number of executable format data is overlapped with the variable number used in the header. <p>Modify the program.</p>

Number	Message	Description
178	G05 COMMANDED IN G41/G42 MODE	G05 was commanded in the G41/G42 mode. Correct the program.
179	PARAM. (NO. 7510) SETTING ERROR	The number of controlled axes set by the parameter 7510 exceeds the maximum number. Modify the parameter setting value.

Warning

WARNING

Single block stop, dry run, feedrate override, automatic acceleration/deceleration and handle interruption are disabled during high-speed cycle cutting.

Note

NOTE

Set the total number of distribution data items for one cycle to a multiple of the following values, according to the distribution cycle. This does not apply when the distribution cycle is 16 ms or 8 ms.

If the total number is not a multiple of one of the following values, movement in the remaining cycle becomes zero.

Distribution cycle 4 ms: Multiple of 2

Distribution cycle 2 ms: Multiple of 4

Distribution cycle 1 ms: Multiple of 8

For example, when all 41 data items (distribution cycle: 2 ms) are specified, movement is zero in the remaining 3 ms.

Reference item

Series 16i/18i/160i/180i/ 160is/180is	OPERATOR'S MANUAL (For Machining Center) (B-63534EN)	II.19.1	High speed cycle cutting
	OPERATOR'S MANUAL (For Lathe) (B-63524EN)	II.18.1	High speed cycle cutting

11.6 CUSTOM MACRO

11.6.1 Custom Macro

General

Although subprograms are useful for repeating the same operation, the custom macro function also allows use of variables, arithmetic and logic operations, and conditional branches for easy development of general programs such as pocketing and user-defined canned cycles. A machining program can call a custom macro with a simple command, just like a subprogram.

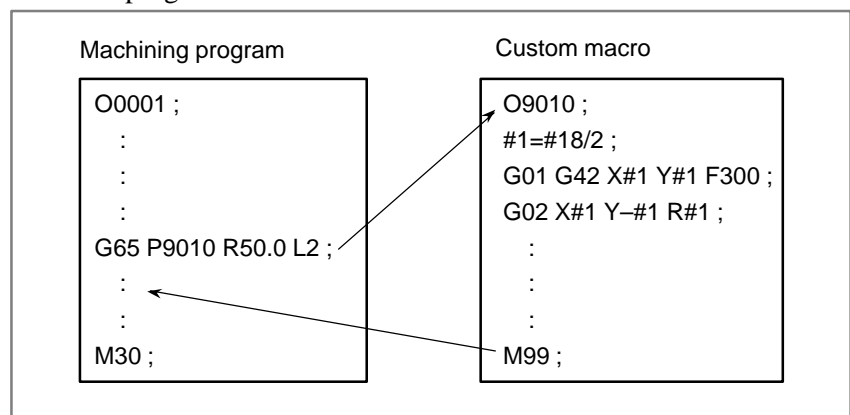

This means that a function of general use can be formed when programming a certain function as a custom macro. That is, programs can be written using variables for data that might change or be unknown. This can be further applied to group technology.

Similar workpieces can be collected as a group and a universal custom macro body can be programmed using variables applicable to each group. In this way, programming is not required for the workpieces in the group. The programmer only need to assign actual values to the variables.

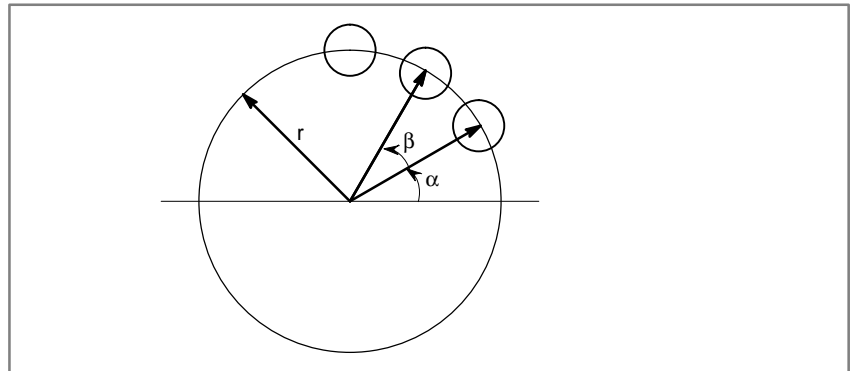

Bolt hole circles as shown in the above figure can be made easily. Once a custom macro body for the bolt hole circle is programmed and registered, the CNC can operate as if it has the bolt hole circle cutting function.

Programmers can use the bolt hole circle function by using the following command only:

(Example of calling bolt hole circle)

G65 Pp Rr Aα Bβ Kk ;

P : Macro number of bolt hole circle
 r : Radius
 α : Start angle
 β : Angle between circles
 k : Number of circles

Signal

Custom Macro Input

Signal

UI000 to UI015

<G054, G055>

UI000 to UI031

<G054 to G057>

UI100 to UI131

<G276 to G279>

UI200 to UI231

<G280 to G283>

UI300 to UI331

<G284 to G287>

[Classification] Input signal

[Function] No function is provided for the control unit. These signals can be read by a custom macro as a type of system variable, and are used for interface signals between custom macros and the PMC.

These signals correspond to system variables as indicated below.

Signals	Q'ty	Variables	Correspondence of values
UI000	1	#1000	"0" at "0" and "1" at "1"
UI001	1	#1001	
UI002	1	#1002	
UI003	1	#1003	
:	:	:	
UI014	1	#1014	
UI015	1	#1015	
UI000 to UI015	16	#1032	16-bit binary code *1

$$*1 \text{ Variable value } \#1032 = \sum_{i=0}^{15} \{ \# [1000 + i] \times 2^i \}$$

To use UI000 to UI031, UI100 to UI131, UI200 to UI231, and UI300 to UI331, set bit 0 (MIF) of parameter No. 6001. See "Parameter" described below.

Custom Macro Output Signal

UI000 to UI015

<F054, F055>

UO100 to UO131

<F056 to F059>

UO100 to UO131

<F056 to F059>

UO000 to UO031

<F054, F055,

F276, F277>

UO200 to UO231

<F280 to F283>

UO300 to UO331

<F284 to F287>

[Classification] Output signal

[Function] No function is provided for the control unit. These signals can be read or written by a custom macro as a type of system variable, and are used for interface signals between custom macros and the PMC.

These signals correspond to system variables as indicated below.

Signals	Q'ty	Variables	Correspondence of values
UO000 UO001 UO002 UO003 : UO014 UO015	1 1 1 1 : 1 1	#1100 #1101 #1102 #1103 : #1114 #1115	"0" at "0" and "1" at "1"
UO000AUO015 UO100AUO115	16 32	#1132 #1133	16-bit binary code *1 32-bit binary code *2

$$*1 \text{ Variable value } \quad \#1132 = \sum_{i=0}^{15} \{ \# [1100 + i] \times 2^i \}$$

$$*2 \text{ Variable value } \quad \#1133 = \sum_{i=0}^{30} \{ 2^i \times V_i \} - 2^{31} \times V_{31}$$

Where $V_i=0$ when UO1i is H0 and $V_i=1$ when UO1i is H1

These system variables can be used on the left side of an assignment statement as well as on the right side.

The value assigned to the system variable used on the left side last is used for the value of the system variable to be assigned on the right side.

To use UO000 to UO031, UO200 to UO231, and UO300 to UO331, set bit 0 (MIF) of parameter No. 6001. See "Parameter" described below.

Signal address

	#7	#6	#5	#4	#3	#2	#1	#0
G054	UI007	UI006	UI005	UI004	UI003	UI002	UI001	UI000
G055	UI015	UI014	UI013	UI012	UI011	UI010	UI009	UI008
G056	UI023	UI022	UI021	UI020	UI019	UI018	UI017	UI016
G057	UI031	UI030	UI029	UI028	UI027	UI026	UI025	UI024
G276	UI107	UI106	UI105	UI104	UI103	UI102	UI101	UI100
G277	UI115	UI114	UI113	UI112	UI111	UI110	UI109	UI108
G278	UI123	UI122	UI121	UI120	UI119	UI118	UI117	UI116
G279	UI131	UI130	UI129	UI128	UI127	UI126	UI125	UI124
G280	UI207	UI206	UI205	UI204	UI203	UI202	UI201	UI200
G281	UI215	UI214	UI213	UI212	UI211	UI210	UI209	UI208
G282	UI223	UI222	UI221	UI220	UI219	UI218	UI217	UI216
G283	UI231	UI230	UI229	UI228	UI227	UI226	UI225	UI224
G284	UI307	UI306	UI305	UI304	UI303	UI302	UI301	UI300
G285	UI315	UI314	UI313	UI312	UI311	UI310	UI309	UI308
G286	UI323	UI322	UI321	UI320	UI319	UI318	UI317	UI316
G287	UI331	UI330	UI329	UI328	UI327	UI326	UI325	UI324
	#7	#6	#5	#4	#3	#2	#1	#0
F054	UO007	UO006	UO005	UO004	UO003	UO002	UO001	UO000
F055	UO015	UO014	UO013	UO012	UO011	UO010	UO009	UO008
F056	UO107	UO106	UO105	UO104	UO103	UO102	UO101	UO100
F057	UO115	UO114	UO113	UO112	UO111	UO110	UO109	UO108
F058	UO123	UO122	UO121	UO120	UO119	UO118	UO117	UO116
F059	UO131	UO130	UO129	UO128	UO127	UO126	UO125	UO124
F276	UO023	UO022	UO021	UO020	UO019	UO018	UO017	UO016
F277	UO031	UO030	UO029	UO028	UO027	UO026	UO025	UO024
F280	UO207	UO206	UO205	UO204	UO203	UO202	UO201	UO200
F281	UO215	UO214	UO213	UO212	UO211	UO210	UO209	UO208
F282	UO223	UO222	UO221	UO220	UO219	UO218	UO217	UO216
F283	UO231	UO230	UO229	UO228	UO227	UO226	UO225	UO224
F284	UO307	UO306	UO305	UO304	UO303	UO302	UO301	UO300

	#7	#6	#5	#4	#3	#2	#1	#0
F285	UO315	UO314	UO313	UO312	UO311	UO310	UO309	UO308
F286	UO323	UO322	UO321	UO320	UO319	UO318	UO317	UO316
F287	UO331	UO330	UO329	UO328	UO327	UO326	UO325	UO324

Parameter

- **Settings for executing single block stop and custom macros**

	#7	#6	#5	#4	#3	#2	#1	#0
6000	SBV		SBM	HGO		HMC	MGO	

[Data type] Bit

MGO When a GOTO statement for specifying custom macro control is executed, a high-speed branch to 20 sequence numbers executed from the start of the program is:

0 : A high-speed branch is not caused to n sequence numbers from the start of the executed program.

1 : A high-speed branch is caused to n sequence numbers from the start of the program.

HMC A custom macro is executed:

0 : At a normal speed.

1 : At a high speed.

NOTE

When this parameter is set, the CNC executes a custom macro first. For this reason, when this parameter is set, performance of the following functions may be degraded:

- Screen display of CNC
- C language executor (excluding high-level tasks)
- Macro executor (excluding execution macros)

HGO When a GOTO statement for specifying custom macro control is executed:

0 : A high-speed branch is not caused to 30 sequence numbers, immediately following the point of execution.

1 : A high-speed branch is caused to 30 sequence numbers, immediately before the point of execution.

SBM Custom macro statement

0: Not stop the single block

1: Stops the single block

If you want to disable the single blocks in custom macro statements using system variable #3003, set this parameter to 0. If this parameter is set to 1, the single blocks in custom macro statements cannot be disabled using system variable #3003. To control single blocks in custom macro statements using system variable #3003, use bit 7 (SBV) of parameter No. 6000.

NOTE

This bit is invalid when bit 0 (NOP) of parameter No. 3404 is set to 1. (M series)

SBV Custom macro statement
 0 : Not stop the single block
 1 : Stops the single block

To control single blocks in custom macro statements using system variable #3003, use this parameter to enable or disable single blocks in custom macro statements.

This bit is valid when bit 5 (SBM) of parameter No. 6000 is set to 0.

● **Other settings**

	#7	#6	#5	#4	#3	#2	#1	#0
6001	CLV	CCV	TCS	CRO	PV5		PRT	MIF

[Data type] Bit

MIF System variable numbers of interface signals for custom macros are:
 0 : Extended.
 1 : Not extended.

[Input signals]

The status of each interface signal can be checked by reading the value of the corresponding system variable for reading the interface signal.

System variable	When bit 0 (MIF) of parameter No. 6001 is set to 0		When bit 0 (MIF) of parameter No. 6001 is set to 1	
	Q'ty	Interface input signal	Q'ty	Interface input signal
#1000	1	UI000	1	UI000
#1001	1	UI001	1	UI001
#1002	1	UI002	1	UI002
#1003	1	UI003	1	UI003
#1004	1	UI004	1	UI004
#1005	1	UI005	1	UI005
#1006	1	UI006	1	UI006
#1007	1	UI007	1	UI007
#1008	1	UI008	1	UI008
#1009	1	UI009	1	UI009
#1010	1	UI010	1	UI010
#1011	1	UI011	1	UI011
#1012	1	UI012	1	UI012
#1013	1	UI013	1	UI013
#1014	1	UI014	1	UI014
#1015	1	UI015	1	UI015
#1016			1	UI016
#1017			1	UI017
#1018			1	UI018
#1019			1	UI019
#1020			1	UI020
#1021			1	UI021
#1022			1	UI022
#1023			1	UI023
#1024			1	UI024
#1025			1	UI025
#1026			1	UI026
#1027			1	UI027
#1028			1	UI028
#1029			1	UI029
#1030			1	UI030
#1031			1	UI031
#1032	16	UI000 to UI015	32	UI000 to UI031
#1033			32	UI100 to UI131
#1034			32	UI200 to UI231
#1035			32	UI300 to UI331

[Output signals]

Each interface signal can be sent by assigning a value to the corresponding system variable for sending the interface signal.

System variable	When bit 0 (MIF) of parameter No. 6001 is set to 0		When bit 0 (MIF) of parameter No. 6001 is set to 1	
	Q'ty	Interface output signal	Q'ty	Interface output signal
#1100	1	UO000	1	UO000
#1101	1	UO001	1	UO001
#1102	1	UO002	1	UO002
#1103	1	UO003	1	UO003
#1104	1	UO004	1	UO004
#1105	1	UO005	1	UO005
#1106	1	UO006	1	UO006
#1107	1	UO007	1	UO007
#1108	1	UO008	1	UO008
#1109	1	UO009	1	UO009
#1110	1	UO010	1	UO010
#1111	1	UO011	1	UO011
#1112	1	UO012	1	UO012
#1113	1	UO013	1	UO013
#1114	1	UO014	1	UO014
#1115	1	UO015	1	UO015
#1116			1	UO016
#1117			1	UO017
#1118			1	UO018
#1119			1	UO019
#1120			1	UO020
#1121			1	UO021
#1122			1	UO022
#1123			1	UO023
#1124			1	UO024
#1125			1	UO025
#1126			1	UO026
#1127			1	UO027
#1128			1	UO028
#1129			1	UO029
#1130			1	UO030
#1131			1	UO031
#1132	16	UO000 to UO015	32	UO000 to UO031
#1133	32	UO0100 to UO131	32	UO100 to UO131
#1134			32	UO200 to UO231
#1135			32	UO300 to UO331

PRT Reading zero when data is output using a DPRNT command
 0 : Outputs a space
 1 : Outputs no data

- PV5** Custom macro common variables
 0 : Outputs custom macro common variables #500 through #599.
 1 : Outputs custom macro common variables #100 through #199 and #500 through #599.
- CRO** ISO code output using a BPRNT command or a DPRNT command
 0 : Outputs only LF after data is output
 1 : Outputs LF and CR after data is output
- TCS** Custom macro (subprogram)
 0 : Not called using a T code
 1 : Called using a T code
- CCV** Custom macro's common variables Nos. 100 through 149 (or through 199)
 0 : Cleared to "vacant" by reset
 1 : Not cleared by reset
- CLV** Custom macro's local variables #1 through #33
 0 : Cleared to "vacant" by reset
 1 : Not cleared by reset

● **Setting when macro statement is input/output with EIA code**

	#7	#6	#5	#4	#3	#2	#1	#0
6010	*7	*6	*5	*4	*3	*2	*1	*0
6011	=7	=6	=5	=4	=3	=2	=1	=0
6012	#7	#6	#5	#4	#3	#2	#1	#0
6013	[7	[6	[5	[4	[3	[2	[1	[0
6014]7]6]5]4]3]2]1]0

[Data type] Bit

These parameters are used to input/output macro statements with EIA code.

The numeral of a suffix indicates the bit position in a code.

- *0 to *7** Set the hole pattern of an EIA code indicating *.
- =0 to =7** Set the hole pattern of an EIA code indicating =.
- #0 to #7** Set the hole pattern of an EIA code indicating #.
- [0 to [7** Set the hole pattern of an EIA code indicating [.
-]0 to]7** Set the hole pattern of an EIA code indicating].
- 0 :Corresponding bit is 0
- 1 :Corresponding bit is 1.

- **Setting an M code that calls a program entered in a file**

6030	M code that calls the program entered in file
------	---

[Data type] Byte

[Valid data range] 0, and 1 to 255

When the subprogram call function is used, this parameter sets the M code for calling a program in a file stored on the external input/output device.

NOTE

The M code is judged to be M198 when zero is specified as the setting value.

- **Setting G codes that call custom macros of program Nos.9010 to 9019**

6050	G code that calls the custom macro of program number 9010
6051	G code that calls the custom macro of program number 9011
6052	G code that calls the custom macro of program number 9012
6053	G code that calls the custom macro of program number 9013
6054	G code that calls the custom macro of program number 9014
6055	G code that calls the custom macro of program number 9015
6056	G code that calls the custom macro of program number 9016
6057	G code that calls the custom macro of program number 9017
6058	G code that calls the custom macro of program number 9018
6059	G code that calls the custom macro of program number 9019

[Data type] Word

[Valid data range] 1 to 999

These parameters set the G codes that call the custom macros of program numbers 9010 through 9019.

NOTE

Setting value 0 is invalid. No custom macro can be called by G00.

- **Setting M codes that call subprograms of program Nos.9001 to 9009**

6071	M code that calls the subprogram of program number 9001
6072	M code that calls the subprogram of program number 9002
6073	M code that calls the subprogram of program number 9003
6074	M code that calls the subprogram of program number 9004
6075	M code that calls the subprogram of program number 9005
6076	M code that calls the subprogram of program number 9006
6077	M code that calls the subprogram of program number 9007
6078	M code that calls the subprogram of program number 9008
6079	M code that calls the subprogram of program number 9009

[Data type] Two-word

[Valid data range] 1 to 99999999

These parameters set the M codes that call the subprograms of program numbers 9001 through 9009.

NOTE

Setting value 0 is invalid. No custom macro can be called by M00.

- **Setting M codes that call custom macros of no.9020 to 9029**

6080	M code that calls the custom macro of program number 9020
6081	M code that calls the custom macro of program number 9021
6082	M code that calls the custom macro of program number 9022
6083	M code that calls the custom macro of program number 9023
6084	M code that calls the custom macro of program number 9024
6085	M code that calls the custom macro of program number 9025
6086	M code that calls the custom macro of program number 9026
6087	M code that calls the custom macro of program number 9027
6088	M code that calls the custom macro of program number 9028
6089	M code that calls the custom macro of program number 9029

[Data type] Two-word

[Valid data range] 1 to 99999

These parameters set the M codes that call the custom macros of program numbers 9020 through 9029.

NOTE

Setting value 0 is invalid. No custom macro can be called by M00.

- **ASCII codes that call subprogram of program No. 9004**

6090	ASCII code that calls the subprogram of program number 9004
6091	ASCII code that calls the subprogram of program number 9005

[Data type] Byte

[Valid data range] 65 (A:41H) to 90 (Z:5AH)

These parameters set the ASCII codes that call subprograms in decimal. Addresses that can be used are as follows:

T series : A, B, F, H, I, K, M, P, Q, R, S, T

M series: A, B, D, F, H, I, J, K, L, M, P, Q, R, S, T, X, Y, Z

NOTE

Set 0 when no subprogram is called

Alarm and message

Number	Message	Description
076	ADDRESS P NOT DEFINED	Address P (program number) was not commanded in the block which includes an M98, G65, or G66 command. Modify the program.
077	SUB PROGRAM NESTING ERROR	The subprogram was called in five folds. Modify the program.
078	NUMBER NOT FOUND	A program number or a sequence number which was specified by address P in the block which includes an M98, M99, M65 or G66 was not found. The sequence number specified by a GOTO statement was not found. Otherwise, a called program is being edited in background processing. Correct the program, or discontinue the background editing.
110	DATA OVERFLOW	The absolute value of fixed decimal point display data exceeds the allowable range. Modify the program.
111	CALCULATED DATA OVERFLOW	The result of calculation is out of the allowable range (-10^{47} to -10^{-29} , 0, and 10^{-29} to 10^{47}).
112	DIVIDED BY ZERO	Division by zero was specified. (including $\tan 90^\circ$)
113	IMPROPER COMMAND	A function which cannot be used in custom macro is commanded. Modify the program.

Number	Message	Description
114	FORMAT ERROR IN MACRO	There is an error in other formats than <Formula>. Modify the program.
115	ILLEGAL VARIABLE NUMBER	A value not defined as a variable number is designated in the custom macro, or the header contents are improper in a high-speed cycle cutting. This alarm is given in the following cases: High speed cycle machining 1. The header corresponding to the specified machining cycle number called is not found. 2. The cycle connection data value is out of the allowable range (0 – 999). 3. The number of data in the header is out of the allowable range (0 – 32767). 4. The storing start data variable number of executable format data is out of the allowable range (#20000 – #85535). 5. The storing data variable number of executable format data is out of the allowable range (#85535). 6. The storing start data variable number of executable format data is overlapped with the variable number used in the header. Modify the program.
116	WRITE PROTECTED VARIABLE	The left side of substitution statement is a variable whose substitution is inhibited. Modify the program.
118	PARENTHESIS NESTING ERROR	The nesting of bracket exceeds the upper limit (quintuple). Modify the program.
119	ILLEGAL ARGUMENT	The SQRT argument is negative, BCD argument is negative, or other values than 0 to 9 are present on each line of BIN argument. Modify the program.
122	DUPLICATE MACRO MODAL-CALL	The macro modal call is specified in double. Modify the program.
123	CAN NOT USE MACRO COMMAND IN DNC	Macro control command is used during DNC operation. Modify the program.
124	MISSING END STATEMENT	DO – END does not correspond to 1 : 1. Modify the program.
125	FORMAT ERROR IN MACRO	<Formula> format is erroneous. Modify the program.
126	ILLEGAL LOOP NUMBER	In DOn, $1 \leq n \leq 3$ is not established. Modify the program.
127	NC, MACRO STATEMENT IN SAME BLOCK	NC and custom macro commands coexist. Modify the program.
128	ILLEGAL MACRO SEQUENCE NUMBER	The sequence number specified in the branch command was not 0 to 9999. Or, it cannot be searched. Modify the program.

Number	Message	Description
129	ILLEGAL ARGUMENT ADDRESS	An address which is not allowed in <Argument Designation > is used. Modify the program.
199	MACRO WORD UNDEFINED	Undefined macro word was used. Modify the custom macro.

Caution

CAUTION

Machine tool builders: You are requested to attach your custom macro program tape or program list to the CNC unit without fail.

If it is necessary to replace part program storage memory due to a failure, FANUC servicemen or end user in charge of maintenance should know the contents of your custom macro for the purpose of repairing the trouble immediately.

Reference item

Series 16 <i>i</i> /18 <i>i</i> /160 <i>i</i> /180 <i>i</i> / 160 <i>is</i> /180 <i>is</i>	OPERATOR'S MANUAL (For Machining Center) (B-63534EN)	II.15	Custom macro
	OPERATOR'S MANUAL (For Lathe) (B-63524EN)	II.15	Custom macro
Series 21 <i>i</i> /210 <i>i</i> /210 <i>is</i>	OPERATOR'S MANUAL (For Machining Center) (B-63614EN)	II.15	Custom macro
	OPERATOR'S MANUAL (For Lathe) (B-63604EN)	II.15	Custom macro
Series 20 <i>i</i>	OPERATOR'S MANUAL (For Manual Milling Machine) (B-64204EN)	II.15	Custom macro
	OPERATOR'S MANUAL (For Manual Lathes) (B-64194EN)	II.15	Custom macro

11.6.2 Interruption Type Custom Macro

General

When a program is being executed, another program can be called by inputting an interrupt signal (UINT) from the machine. This function is referred to as an interruption type custom macro function. Program an interrupt command in the following format:

M96 P○○○○ ;	Enables custom macro interrupt
M97 ;	Disables custom macro interrupt

Use of the interruption type custom macro function allows the user to call a program during execution of an arbitrary block of another program. This allows programs to be operated to match situations which vary from time to time.

- (1) When a tool abnormality is detected, processing to handle the abnormality is started by an external signal.
- (2) A sequence of machining operations is interrupted by another machining operation without the cancellation of the current operation.
- (3) At regular intervals, information on current machining is read.

Listed above are examples like adaptive control applications of the interruption type custom macro function.

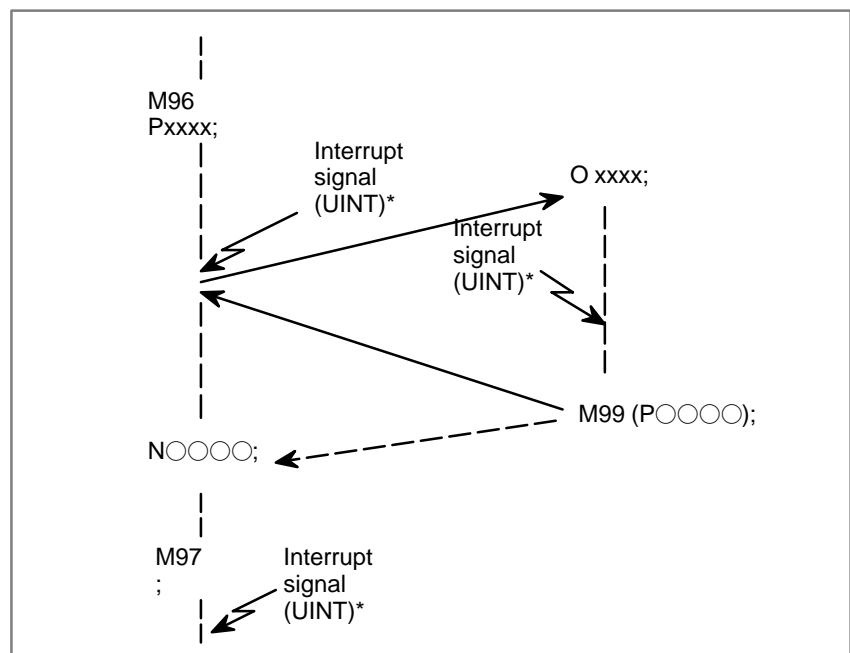

Fig 11.6.2 Interruption type custom macro function

When M96Pxxxx is specified in a program, subsequent program operation can be interrupted by an interrupt signal (UINT) input to execute the program specified by Pxxxx.

Any interrupt signal (UNIT, asterisked in Fig. 11.6.2) issued after M97 is ignored.

Do not enter an interrupt signal during execution of an interrupt macro.

Signal

Interrupt Signal for Custom Macro UINT<G053#3>

[Classification] Input signal

[Function] This signal calls and executes a program in memory. During execution, a program in automatic operation is suspended.

To enable this signal to be accepted, a particular miscellaneous function must be specified in a command program for automatic operation. In addition, automatic operation must already be started to accept this signal. The particular miscellaneous function code is set by parameter 6003, 6033 and 6034.

Signal address

	#7	#6	#5	#4	#3	#2	#1	#0
G053					UINT			

Parameter

• Various Setting for Custom Macro

	#7	#6	#5	#4	#3	#2	#1	#0
6003	MUS	MCY	MSB	MPR	TSE	MIN	MSK	

[Data type] Bit

MSK Absolute coordinates at that time during custom macro interrupt

0 : Not set to the skip coordinates (system variables #5061 and later)

1 : Set to the skip coordinates (system variables #5601 and later)

MIN Custom macro interrupt

0 : Performed by interrupting an in-execution block (Custom macro interrupt type I)

1 : Performed after an in-execution block is completed (Custom macro interrupt type II)

TSE Custom macro interrupt signal UINT

0 : Edge trigger method (Rising edge)

1 : Status trigger method

- MPR** Custom macro interrupt valid/invalid M code
 0 : M96/M97
 1 : M code set using parameters (Nos. 6033 and 6034)
- MSB** Interrupt program
 0 : Uses a dedicated local variable (Macro-type interrupt)
 1 : Uses the same local variable as in the main program (Subprogram-type interrupt)
- MCY** Custom macro interrupt
 0 : Not performed during cycle operation
 1 : Performed during cycle operation
- MUS** Interrupt-type custom macro
 0 : Not used
 1 : Used

- **Setting M code that makes interruption effective and ineffective**

6033	M code that validates a custom macro interrupt
6034	M code that invalidates a custom macro interrupt

[Data type] Byte type

[Valid data range] 0 to 255

These parameters set the custom macro interrupt valid/invalid M codes.

NOTE

These parameters can be used when MPR, #4 of parameter No. 6003, is 1. M96 is used as a valid M code and M97 is used as an invalid M code when MPR is 0, irrespective of the state of this parameter.

Note

NOTE

- 1 No interrupt-type custom macro can be used during DNC operation.
- 2 No interrupt-type custom macro can be used during multiple repetitive canned cycle execution.

Reference item

Series 16i/18i/160i/180i/ 160is/180is	OPERATOR'S MANUAL (For Machining Center) (B-63534EN)	II.15.11	Interruption type custom macro
	OPERATOR'S MANUAL (For Lathe) (B-63524EN)	II.15.11	Interruption type custom macro
Series 21i/210i/210is	OPERATOR'S MANUAL (For Machining Center) (B-63614EN)	II.15.11	Interruption type custom macro
	OPERATOR'S MANUAL (For Lathe) (B-63604EN)	II.15.11	Interruption type custom macro
Series 20i	OPERATOR'S MANUAL (For Manual Lathes) (B-64194EN)	II.15.11	Custom macro

11.6.3 Custom Macro Variables Common to Two-path Control (Two-path Control)

General

With two-path control, common variables are provided separately for each path; variable #n used with a path 1 is different from variable #n used with path 2. By parameter setting (No. 6036 and No. 6037), however, some or all of common variables #100 to #149 and #500 to #531 can be made usable commonly by path 1 and path 2 so that such variables can be written or read for either path. Such variables are referred to as custom macro variables common between two paths.

Parameter

- **Setting the no. of custom macro variables common between two paths**

6036

Number of custom macro variables common between two paths (#100's)

[Data type] Byte

[Unit of data] Number of custom macro variables

[Valid data range] 0 to 50

The parameter specifies the number of variables commonly used for both paths 1 and 2 (custom macro variables common between two paths) that are included in custom macro variables 100 to 149.

The custom macro variables common between two paths can be written or read for either of the paths.

Example) When this parameter is set to 10, the custom macro variables are specified as follows:

Custom macro variables 100 to 109: Used commonly between two paths

Custom macro variables 110 to 149: Used independently for each path

NOTE

- 1 This parameter is dedicated to the 2-path control.
- 2 When this parameter is set to 0, custom macro variables 100 to 149 are not used commonly between two paths.

● **Setting the No. of custom macro variables common between two paths**

6037	Number of custom macro variables common between two paths (#500's)
------	--

[Data type] Byte

[Unit of data] Number of custom macro variables

[Valid data range] 0 to 32

This parameter specifies the number of variables commonly used for both paths 1 and 2 (custom macro variables common between two paths) that are part of custom macro variables 500 to 531.

The custom macro variables common to tool posts can be written or read for either of the tool posts.

Example) When this parameter is set to 10, the custom macro variables are specified as follows:

Custom macro variables 500 to 509: Used commonly between two paths

Custom macro variables 510 to 531: Used independently for each path

NOTE

- 1 This parameter is dedicated to the 2-path control.
- 2 When this parameter is set to 0, custom macro variables 500 to 531 are not used commonly between two paths.

Reference item

Series 16i/18i/160i/180i/ 160is/180is	OPERATOR'S MANUAL (For Machining Center) (B-63534EN)	II.21.3	Custom macro variables com- mon to tool posts
	OPERATOR'S MANUAL (For Lathe) (B-63524EN)	II.20.5	Custom macro variables com- mon to tool posts

11.6.4 Embedded Macro

Outline

In this function, the macro programs, which are made by the machine tool builder (MTB), are stored in flash ROM. The macro programs, which are stored in flash ROM, are loaded to the program memory area for the embedded macro (DRAM) when the power supply is turned on. And an operator can call the macro programs from the CNC programs in a usual tape storage memory area. The macro programs on DRAM can be edited as well as a usual CNC program. It is possible to store the edited macro programs to flash ROM (FROM) by softkey operation. And it is possible to prohibit editing the embedded macro programs by an arbitrary password setting.

Normally, all CNC programs are stored in the tape storage memory area. Therefore, the capacity of the program, which an operator can use, decreases when the programs made by the MTB are large size. The MTB can make the programs without decreasing the capacity of the user program because the macro programs made by MTB are stored in another tape storage memory area by this function. (The macro programs that are corresponding to 225m in tape storage length can be registered.) And because the macro programs are stored in flash ROM, the macro programs are not deleted by the miss-operation etc. such as mistaken all clear operation.

Specification

- **Composition of function** CNC

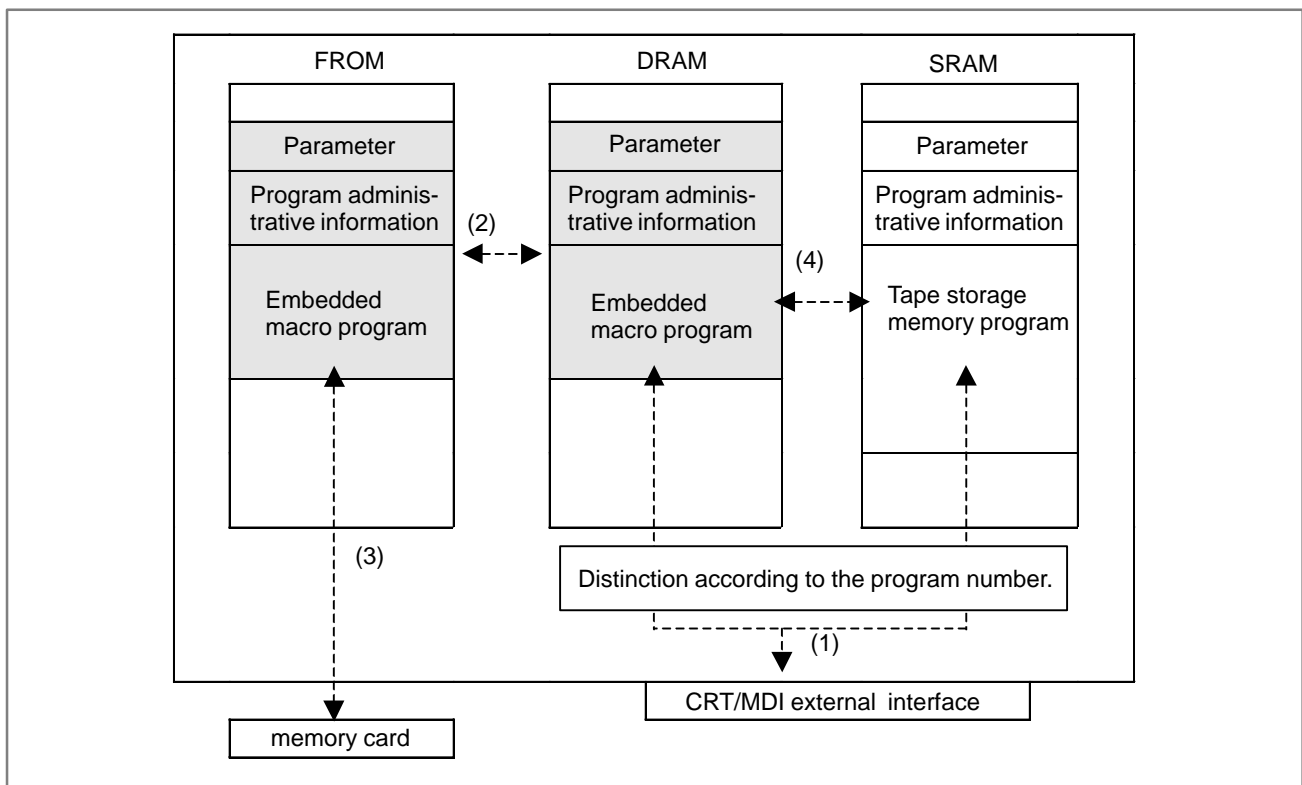

- **Parameter (parameter for embedded macro)**

Parameters for embedded macro exist both FROM and DRAM. If the keyword in the parameters of FROM is not matched that of SRAM (lock state), the embedded macro function executes by using the parameters on FROM. When the keyword is matched on both FROM and SRAM (unlock state), this function executes by using the parameters on SRAM as usual.
- **Program administrative information**

The macro programs made by MTB and the CNC programs made by an operator are administrated. Directory information of the program, program number, program update time, and a size, etc. are administrated as data. The data of the SRAM is used usually. The data on the DRAM and FROM are used for maintenance.
- **Embedded macro program (macro program)**

The macro programs made by MTB are stored. When the embedded macro program is edited, an operator edits the program on DRAM and the edited program is stored in FROM by the softkey operation. When the embedded macro program is edited, it is necessary to store the program in FROM because the program on DRAM is deleted when the power supply is turned on again.
- **Tape storage memory program (user program)**

The CNC programs made by a user (operator). Even if the power supply is turned on again, the programs are not deleted.

Operation

- (1) Edit of embedded macro program

The macro programs on DRAM can be edited on the program screen. And parameter setting can prohibit the edit of the embedded macro program. The edit operation is the same as the edit of the normal user program. Program input/output operation is also the same as that of the normal user program. The embedded macro programs and the user programs are distinguished according to the program number.
- (2) Programs writing from DRAM to FROM and programs reading from FROM to DRAM

The embedded macro programs on DRAM can be written to FROM by the softkey operation. At the same time, the program administrative information and the embedded macro parameters are forwarded from SRAM to DRAM, and written from DRAM to FROM. When the power supply is turned on, reading from FROM to DRAM is automatically done. At this time, this function is checked whether the program administrative information of SRAM is correct and the parameters for embedded macro are rewritten by FROM data. The program reading from FROM to DRAM is also done by the softkey operation. By this operation, the current DRAM area is overwritten by the data in FROM area.
- (3) Input to FROM and output from FROM

The embedded macro program file stored in FROM can be input and output by BOOT SYSTEM with a memory card.
- (4) Call of embedded macro

It is possible to call the embedded macro programs by using G-code call for the embedded macro. And it is also possible to call them by custom macro call (G65, G66) and subprogram call (M98).

Detail

1) Program number

As for the embedded macro program number, the first program number is set to parameter No.12011 and the last program number is set to No.12012. The remainder program numbers become the user program numbers of the tape storage memory area. When the keyword is matched the password (unlock state) and no program exists, the parameters for embedded macro program number can be changed.

Example) In case that the program No. is 4 digits

Parameter No. 12011 = 1234

Parameter No. 12012 = 5678

Embedded macro programs No. = O1234 to O5678

User programs No. = O0001 to O1233
O5679 to O9999

On the program list screen, the embedded macro program number is displayed as "*" instead of "O".

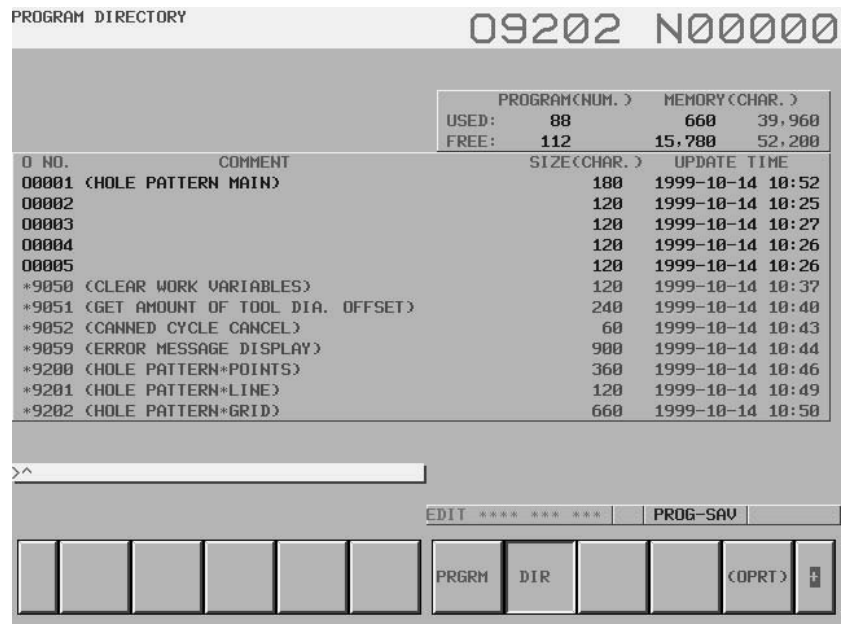

2) Edit of embedded macro program

The embedded macro programs on DRAM can be edited by the operation same as the CNC programs of the tape storage memory area. And it is possible to input/output by the reader puncher interface. The edit of the embedded macro programs can be prohibited as follows by parameter No.12010 setting. However, the embedded macro data in FROM becomes effective in the state that the key for the embedded macro is effective (lock state).

Prm.No.12010	Editing	Reference
0	×	×
1	×	○
2	○	○

It is not possible to move from the tape storage memory program to the embedded macro program or from the embedded macro program to the tape storage memory program by the program number change operation. P/S alarm 74 is generated when doing.

At the editable state (Parameter No.12010=2 or the data in FROM=2), the free and used capacity of DRAM for the embedded macro are displayed at the right side of the tape memory size display on the program list screen. When it is not possible to refer and to edit the embedded macro program (Parameter No.12010=0 or the data in FROM=0), the embedded macro programs are not displayed.

3) Call of embedded macro program

The embedded macro programs are called by G-codes. The relations between G-codes and calling the embedded macro program numbers are set by the parameter. Max. 10 sets can be specified.

Example) Assume that the embedded macro programs are No.7000-8999.

The first set	The second set	The third set
G-code Prm.No.12020=100	Prm.No.12023=150	Prm.No.12026=900
O No. Prm.No.12021=8000	Prm.No.12024=7500	Prm.No.12027=8300
Number Prm.No.12022=10	Prm.No.12025=100	Prm.No.12028=30

When the parameters are set like above,

G-codes of G100-G109 correspond to O8000-O8009

G-codes of G150-G249 correspond to O7500-O7599

G-codes of G900-G929 correspond to O8300-O8399

Such a relation can be set up to ten sets.

And it is possible to call the embedded macro programs by using macro call (G65, G66, G-code, etc) and subprogram call (M98, M-code, etc).

4) Keyword and Password for embedded macro

When new embedded macro program file (the file name is "INMC" on FROM.) is made, the password (setting range: -99999999 to 99999999) is set in parameter No.12013. And the operation for storing the embedded macro programs in FROM is done, the password is stored in the file "INMC". And the parameter No.12013 becomes 0 when the storing in FROM process ends. The state is entered that the key is locked. When assuming that the password is 0 and the storing in FROM operation is done, the state is not locked.

Please input the password to parameter No.12013 to release the Lock State. And please input the number except the password to parameter No.12013 to enter Lock State. When the CNC is unlocking state, the embedded macro programs can be stored in FROM by softkey operation. And as for the following 1-5 items, CNC uses the usual parameter (SRAM) for embedded macro. When the CNC is Lock State, the embedded macro programs cannot be stored in FROM. And CNC uses the parameter in FROM for embedded macro.

1. Valid / invalid of embedded macro program over registration (Parameter No. 12001#0)
2. Valid / invalid of embedded macro program edit and reference (Parameter No. 12010)
3. Embedded macro program No. (Parameter No. 12011,12012)
4. Embedded macro series/edition (Parameter No. 12015,12016)

5. Embedded macro-calling G-code and program No. (Parameter No. 12020 – 12049)

At meeting all the following requirements, the parameter number 12013 keyword cannot be changed.

- (1) There is a password. (Password \neq 0)
- (2) The range of the embedded macro program number in the embedded data of FROM is different from the range of the embedded macro program number in the parameters.
- (3) The programs are registered.

- 5) Programs writing from DRAM to FROM

The embedded macro programs on DRAM are written in FROM by following operation.

- (1) Select the EDIT mode.
- (2) Push the softkey [PROG].
- (3) Push the softkey [(OPRT)].
- (4) Push the right side softkey several times.
- (5) Push the softkey [SAVE].
- (6) Push the softkey [EXEC].

When above operation is done, all the macro programs on DRAM are stored in FROM in the lump as the file name "INMC". At the same time, the program administrative information and the parameters of embedded macro are also stored in "INMC" file in FROM.

The softkey [SAVE] is not displayed when the CNC is Lock State. Please be careful that it is necessary to do the save operation if the macro programs are changed because the edited programs are on DRAM area. So, when the CNC power supply is turned off without storing in FROM, the edited programs are deleted.

- 6) Programs reading from FROM to DRAM

"INMC" file in FROM is loaded to DRAM for embedded macro program area when the power supply is turned on. Then, the parameter No.12001–12049 for the embedded macro function are rewritten by the data of "INMC" in FROM. After that, the collation check on whether the program administrative information in both DRAM and SRAM are matched each other is done. If the collation is not matched, all embedded macro programs on DRAM are deleted.

It is also possible to load the macro program in FROM to DRAM by following operation.

- (1) Select the EDIT mode and display the program screen
- (2) Push the softkey [PROG].
- (3) Push the softkey [(OPRT)].
- (4) Push the right side softkey several times.
- (5) Push the softkey [RELOAD].
- (6) Push the softkey [EXEC].

By this operation, the programs of DRAM are deleted. And the macro programs in FROM are loaded. Then, the parameters for the embedded macro are rewritten by FROM data.

- 7) Input to FROM and output from FROM
The "INMC" file for the embedded macro stored in FROM can be input and output to the memory card by BOOT SYSTEM. Please refer to the maintenance manual for the details.
- 8) Common variables #200 – #499
Common variables #200 – #499 can be used by this function. The treatment of these variables is similar to #100 – #149 (– #199).
- (1) Common variables #200 – #499 are initialized and become <empty> when the power supply is turned off.
 - (2) When embedded macro data is reloaded by the softkey [RELOAD], common variables #200 – #499 become <empty>.
 - (3) When parameter PV5 (No.6001#3) is 1, common variables #200 – #499 can be outputted same as #100 – and #500 –.
 - (4) When parameter CCV (No.6001#6) is 1, common variables #200 – #499 are cleared to <empty> by reset same as #100 –. When CCV is 0, they are not cleared by reset.
 - (5) Common variables #200 – #499 can not be read and written from the window function.
- 9) Series / Edition
The embedded macro file can manage by the series and edition. It is possible to set the four digits number to the parameter No.12015 as the series and the four digits number to the parameter No. 12016 as the edition. And this series / edition can be stored by the [SAVE] operation of the embedded macro data. The series / edition of the embedded macro file is displayed at the right of "EMBED MCR" of the system configuration screen. The embedded macro function can not be used when "EMBED MCR" is not displayed, and when the series / edition is not displayed, the series / edition is not set or the state that there is no "INMC" file in FROM.

Embedded macro program making procedure

- New making (1)
 - 1) Do the program all clear operation. ("O-9999"+[DELETE])
 - 2) Decide the embedded macro programs Nos. and input the decided programs Nos. to the parameter No.12011 and 12012.
 - 3) Enable to edit the embedded macro programs. (Parameter No.12010 =2)
 - 4) Decide the calling G-codes and the calling macro program numbers for embedded macro programs and input to parameter No. 12020 to 12049.
 - 5) Edit the embedded macro programs.
 - 6) Decide the treatment of edited embedded macro programs (edit / reference enable) and input to parameter No.12010.
 - 7) Decide the series and edition, and input to parameter No.12015 and 12016.
 - 8) Decide the password and input to parameter No.12013.
 - 9) Do the writing from DRAM to FROM operation.

NOTE

- 1 When one program exists, the parameters for embedded macro program number can not be changed.
- 2 During 5) – 9) processes, if the CNC power supply is turned off and on without storing macro program in FROM, macro programs are deleted.

- New making (2)
 - 1) Decide the embedded macro programs Nos. (Do not input to the parameter No.12011 and 12012.)
 - 2) Decide the calling G-codes and the calling macro program numbers for embedded macro programs and input to parameter No. 12020 to 12049.
 - 3) Edit the programs for embedded macro in the tape storage memory area as temporary programs.
 - 4) Check the program executions and output all programs to an external device, for instance, the memory card and so on.
 - 5) Do from 1) of new making (1). Input the embedded macro programs from an external device.
- Correction/change/addition
 - 1) Release the password for embedded macro programs in FROM by the keyword.
 - 2) Change the parameters of the calling G-codes, calling program numbers if necessary.
 - 3) Change the parameter of edit / reference the embedded macro programs if necessary.
 - 4) Edit the embedded macro programs.
 - 5) Change the parameter of edit / reference the embedded macro programs.
 - 6) Change the series and edition.
 - 7) Store the embedded macro programs in FROM.

It is not possible to change "password". Please make new embedded macro file if necessary to change "password". In order to change "embedded macro program number", it is necessary to delete all programs. Please change the embedded macro program to unlock state and delete all programs.
- Reproduction
 - 1) Output the programs in area of the tape storage memory to an external device.
 - 2) Save the embedded macro file "INMC" to the memory card by using Boot system.
 - 3) Store the "INMC" file, which is saved at 2), in FROM by using Boot system.
 - 4) Start up the CNC while pushing the [DELETE] key. (At this time, the programs in the tape storage memory area are deleted and the embedded macro programs in FROM are loaded to DRAM.)

Message

Following messages are displayed in the place on present time.

- "PROG-SAV" — Please stores the embedded macro programs.
This display is blink when the embedded macro programs are edited. It informs that the contents of edited the embedded macro programs are deleted if the power supply is turned off / on with current state. In this case, please store the new embedded macro programs to FROM by <SAVE> operation or reload the old embedded macro programs from FROM by <RELOAD> operation.
- "PROG-ERR" — The embedded macro program information is abnormal.
It informs that the content of the embedded macro program information and the embedded programs is not matched. When the embedded macro program is edited (state of "PROG-SAVE") and the power supply is turned off / on without storing FROM, this display is blink. In this case, please reload the embedded macro programs from FROM by <RELOAD> operation.
- "PROG-PRT" — The range of the embedded macro program number cannot be changed.
This display is blink when it is not possible to change within the range of the embedded macro program number of the embedded macro data. The number set in the range of the embedded macro program number of the embedded macro data in FROM is different from the parameter No. 12011 and 12012, and the program exists in CNC. In this case, please delete all programs (O-9999 + [DELETE]) operation, and do <RELOAD> operation.

Notes

- 1) Please store the embedded macro programs in FROM by the embedded macro program save operation after doing program registration, change and deletion. When the programs store is not executed after changing embedded macro programs, the blinking PROG-SAV is displayed on current time display and it informs to an operator that program store has not been done yet in order not to turn off the CNC power supply.

By editing the embedded macro program, the program administrative information (SRAM) and the contents of the embedded macro program (DRAM) are updated. Then if the CNC power supply is turned off/on, the program administrative information (SRAM) is differed from the contents of the embedded macro program (DRAM) because the contents of the embedded macro program is rewritten by that in FROM.

When the CNC power supply is turned on, CNC checks whether the macro program administrative information of both SRAM and DRAM are matched. If these information are difference, all embedded macro programs on DRAM are deleted. In this case, the contents of the embedded macro programs can not be referred and be executed though the programs in a usual tape storage memory area are referred and executed. In order to inform this state, the reverse PROG-ERR is displayed on current time display. If this message is displayed, please do reload operation by softkey [RELOAD]. By this operation, the embedded macro programs in FROM are loaded correctly and are used normally.

There is no problem even if a program in a usual tape storage memory area is edited or the parameter for embedded macro is changed and the CNC power supply is turned off/on.

- 2) At the editable embedded macro program state, when program all clear operation ("O-9999"+[DELETE] or turning on the CNC power supply while pushing [DELETE]) is done, the "PROG-SAV" message is display. In this case, if <SAVE> operation is done, the embedded macro programs in FROM are deleted.
- 3) When one program is registered, the program number for embedded macro can not be changed. In this case, please save all programs to an external device and delete all programs. And please change the parameter No.12011 and 12012 afterwards, and change the program number for embedded macro.
- 4) The password for the embedded macro can not be changed when setting the password once. In order to change the password, please make the file for embedded macro newly. In this case, please do the following process.
 - (a) Output the embedded macro programs to an external device.
 - (b) Delete the file for embedded macro "INMC" with Boot system.
 - (c) Delete all programs.
 - (d) Read the saved programs from an external device.
 - (e) Confirm the parameters for embedded macro.
 - (f) Input the new password to the parameter No.12013.
 - (g) Do the writing from DRAM to FROM operation.
- 5) When the file for embedded macro "INMC" exists in FROM and the file is loaded to DRAM, the parameter No.12001 to 12049 are rewritten by the values of the embedded macro data. And 0 is written to parameter No.12013 at this time.
- 6) When all programs are deleted to clear of "PROG-PRT" state ("O-9999"+[DELETE]), the edit prohibition of No.9000 (90000000) – and No.8000 (80000000) – programs should be released. And please do program all clear operation.
- 7) The embedded macro file "INMC" made at the program number 4 digits can not be used when the program number 8 digits function is used. Similarly, the embedded macro of the program number 8 digits can not be used when the program number 4 digits is used.
- 8) Please do program all clear operation if deleting the embedded macro file "INMC" or storing new embedded macro file "INMC" by using Boot system
- 9) Please do not turn off the power supply when storing the embedded macro programs in FROM (When "INPUT" is blinked). FROM might break.
- 10) The size of the macro program area is corresponding to 225m in tape storage length.
- 11) This function can not be used on 1 CPU with 2-path system, 2 CPUs with 3-path system (T series) and background graphic display system (M series).

Parameter

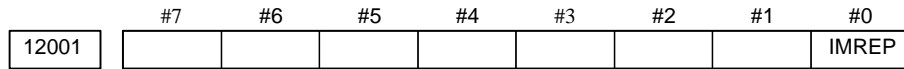

[Data type] Bit

IMREP Action in response to an attempt to register an embedded macro program whose number is the same as that of an existing program

0 : An alarm is generated.

1 : The existing program is deleted, then the new program is registered.

Note that if the existing program is protected from being edited, it is not deleted, and an alarm is generated.

REP (Prm.No.3201#2)	IMREP (Prm.No.12001#0)	Tape storage memory program	Embedded macro program
0	0	Alarm	Alarm
0	1	Alarm	Registration
1	0	Registration	Alarm
1	1	Registration	Registration

NOTE

- 1 When the CNC power supply is turned on or the <RELOAD> operation is done, this parameter is rewritten by the embedded macro data in FROM.
- 2 When the CNC is Lock State, the embedded macro data in FROM is used.

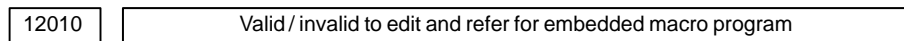

[Data type] Byte

[Valid data range] 0 to 2

By setting the table below, it is possible to enable/disable the embedded macro program to edit and refer.

Prm.No.12010	Editing	Reference
0	×	×
1	×	○
2	○	○

NOTE

- 1 When the CNC power supply is turned on or the <RELOAD> operation is done, this parameter is rewritten by the embedded macro data in FROM.
- 2 When the CNC is Lock State, the embedded macro data in FROM is used.

12011	First program number for embedded macro
-------	---

[Data type] 2-Word

[Valid data range] 1 to 99999999

12012	Last program number for embedded macro
-------	--

[Data type] 2-Word

[Valid data range] 1 to 99999999

The program numbers for embedded macro are set by these parameters. The program numbers other than setting are usual tape storage memory programs.

Example) In case that the program No. is 4 digits

Parameter No. 12011 = 1234

Parameter No. 12012 = 5678

Embedded macro programs No. = O1234 to O5678

User programs No. = O0001 to O1233

O5679 to O9999

NOTE

- 1 When the CNC power supply is turned on or the <RELOAD> operation is done, these parameters are rewritten by the embedded macro data in FROM.
- 2 When the CNC is Lock State, the embedded macro data in FROM is used.
- 3 When one program exists, this parameter can not be changed.

12013	Password / Keyword for embedded macro
-------	---------------------------------------

[Data type] 2-Word

[Valid data range] -99999999 to 99999999

When the embedded macro programs are stored in FROM, this parameter is set as a password. When store in FROM ends, this parameter becomes 0 automatically. After that, this parameter uses as a keyword. And after the CNC power supply is turned on, this parameter becomes 0.

The CNC is unlock state at a keyword = a password.

The CNC is lock state at a keyword <> a password.

(The lock state will be released at a keyword = a password.)

When password is 0 or there is no "INMC" file in FROM, the CNC is unlock state regardless of keyword parameter setting.

- When the CNC is Lock State, the embedded macro programs can not be stored in FROM. And as for the following 1-5 items, CNC uses the parameter in FROM for embedded macro.
- When the CNC is Unlock state, the embedded macro program can be stored in FROM. And as for the following 1-5 items, CNC uses the usual parameter for embedded macro.

1. Valid / invalid of embedded macro program over registration (Parameter No. 12001#0)
2. Valid / invalid of embedded macro program edit and reference (Parameter No. 12010)
3. Embedded macro program No. (Parameter No. 12011,12012)
4. Embedded macro series/edition (Parameter No. 12015,12016)
5. Embedded macro-calling G-code and program No. (Parameter No. 12020 – 12049)

NOTE

- 1 The password can not be changed when password is set once.
- 2 The keyword can not be changed if following conditions are all met.
 - 1) The password is set. (Password <> 0)
 - 2) The program numbers for embedded macro in FROM are differed from that of parameter setting.
 - 3) A program is registered.

12015	Series for embedded macro
-------	---------------------------

[Data type] Word

[Valid data range] 0 to 9999

12016	Edition for embedded macro
-------	----------------------------

[Data type] Word

[Valid data range] 0 to 9999

The series and edition of the FROM file for the embedded macro is set. When the embedded macro data is stored, The series and edition is also stored in FROM file and they can be confirmed on the system configuration screen.

NOTE

- 1 When the CNC power supply is turned on or the <RELOAD> operation is done, these parameters are rewritten by the embedded macro data in FROM.
- 2 When the CNC is Lock State, the embedded macro data in FROM is used.
- 3 When this parameter is set 0, the series / edition is not displayed on the system configuration screen.

12020	G-code No. for embedded macro	(the 1st set)
12023	G-code No. for embedded macro	(the 2nd set)
:	:	:
:	:	:
12047	G-code No. for embedded macro	(the 10th set)

[Data type] Word

[Valid data range] 1 to 999

12021	Macro programs No. for embedded macro	(the 1st set)
12024	Macro programs No. for embedded macro	(the 2nd set)
:	:	:
:	:	:
12048	Macro programs No. for embedded macro	(the 10th set)

[Data type] 2-Word

[Valid data range] 1 to 99999999

12022	G-code macro number for embedded macro	(the 1st set)
12025	G-code macro number for embedded macro	(the 2nd set)
:	:	:
:	:	:
12049	G-code macro number for embedded macro	(the 10th set)

[Data type] Byte

[Valid data range] 1 to 255

G-code macro for embedded macro is set. These sets can be specified up to ten sets. The priority is given from a small parameter number set when G-code number comes in succession. When either of G-code number, program number or macro program number parameter is set to 0, the set is invalid.

	The 1st set	The 2nd set	The 3rd set
G-code Prm.No.	12020=100	12023=150	12026=900
O No.	12021=8000	12024=7500	12027=8300
Number Prm.No.	12022=10	12025=100	12028=30

When the parameters are set like above,

G-codes of G100-G109 correspond to O8000-O8009

G-codes of G150-G249 correspond to O7500-O7599

G-codes of G900-G929 correspond to O8300-O8399

NOTE

- 1 When the CNC power supply is turned on or the <RELOAD> operation is done, these parameters are rewritten by the embedded macro data in FROM.
- 2 When the CNC is Lock State, the embedded macro data in FROM is used.

11.6.5 Embedded macro for milling (M series)

Outline

Embedded macro for milling is available for programming four canned cycles (Hole machining, Facing, Side cutting, Pocketing). The G codes from G200 to G233 are used to call the macro. In addition, of alarms 3000 to 3999 that can be issued by custom macros, alarms 3001 to 3022 are also used. The G codes and alarm numbers used in this function must not duplicate those of other custom macros.

Details

The following descriptions show how to program each canned cycle.

- **Hole pattern**

The following menus are used for definition of hole's position for the machining cycle of hole.

Therefore these are used just behind the program of the machining cycle of hole. For creating a program of the machining cycle of hole, refer to "OPERATOR'S MANUAL(M series)".

#Example of a Hole pattern program

O0001(HOLE PATTERN)

G90G81Z-10.0R3.0F200.K0————Machining cycle of hole

G200X4.0Y4.0A-4.0B4.0C-4.0D-4.0Q1.0—Hole pattern

G80G28G91X0Y0Z0

M30

- **Points (G200)**

This is a menu for specifying the arbitrary hole positions.

Create ISO code program in the following form.

G200 X__ Y__ Q__ (A__ B__ C__ D__ E__ F__ ●●●●);

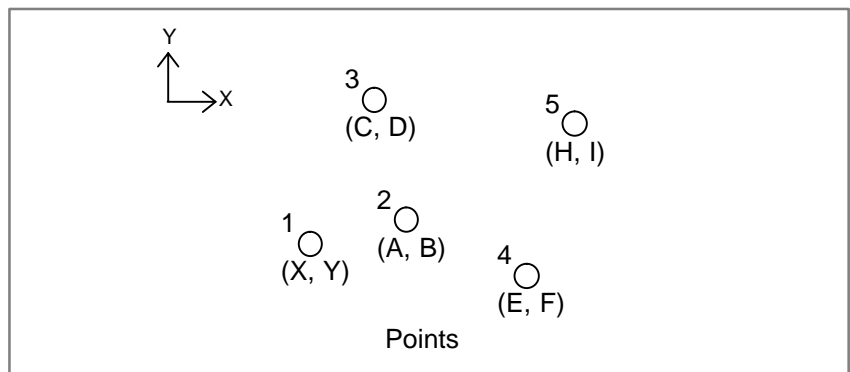

X: Point X

X coordinate of the position of each hole.

Y: Point Y

Y coordinate of the position of each hole.

A maximum of 8 points can be specified. The following table shows addresses, which are used in arguments for X and Y coordinate of the position of each hole.

	X coordinate	Y coordinate
Point - 1	X	Y
Point - 2	A	B
Point - 3	C	D
Point - 4	E	F
Point - 5	H	I
Point - 6	J	K
Point - 7	R	S
Point - 8	T	U

Q: Pattern continue

Selection whether to continue entering another hole pattern.

- 1: End
- 2: Continue

#Example of a Hole pattern program (how to use address Q)

O0002(HOLE PATTERN)

G90G81Z-10.0R3.0F200.K0

G200X4.0Y4.0A-4.0B4.0C-4.0D-4.0Q1.0——Hole pattern (Points)

G201W1.0X1.0Y0A45.0N2.0T5.0Q2.0——Hole pattern (Line)

G28G91X0Y0Z0-

M30

● **Line (G201)**

This is a menu for specifying the pattern of hole positions at same or different spaces on arbitrary line.

Create ISO code program in the following form.

G201 W_ X_ Y_ A_ N_ T_ Q_ (R_ B_ C_ ●●●●);

W: Space

- 1. Same space
- 2. Different space

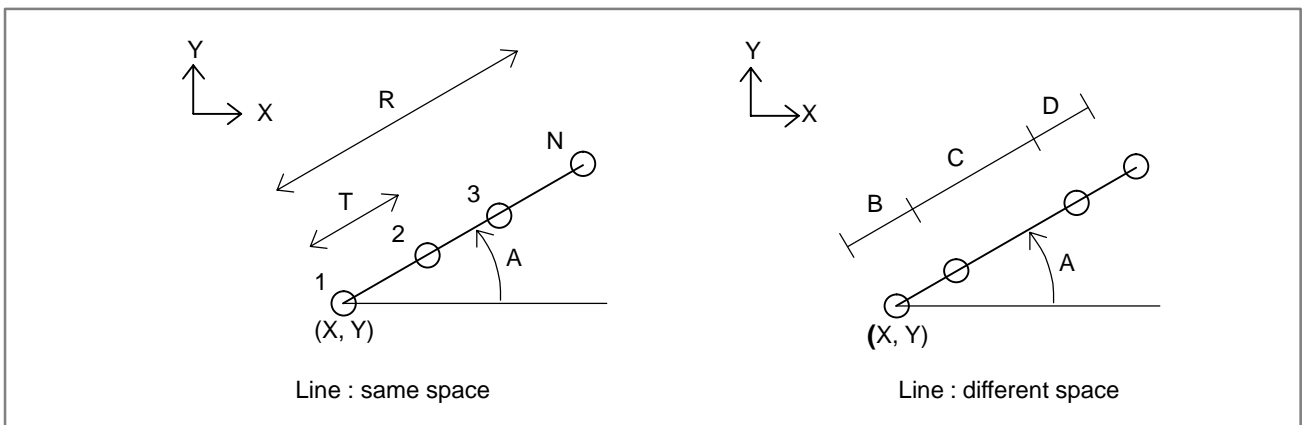

● In the case of Same space :

X: Start point X

X coordinate of the position of first hole.

Y: Start point Y

Y coordinate of the position of first hole.

A: Line angle

The angle between the X axis and the straight line.

If there is no input, 0 is regarded.

N: Holes number

The total number of holes, including the number of the points to be omitted.

T: Pitch space

The space in the hole position.

Q: Pattern continue

Selection whether to continue entering another hole pattern.

1: End

2: Continue

R: Line length

The length of the straight. If T(Pitch space) is inputted, this address don't have to be inputted.

Omit point :

To designate the point to be omitted, input the hole drilling sequence number including its points.

Each address to the number is as follows.

Omit point - 1 : B

Omit point - 2 : C

Omit point - 3 : D

Omit point - 4 : E

- In the case of Different space :

X: Start point X

X coordinate of the position of first hole.

Y: Start point Y

Y coordinate of the position of first hole.

A: Line angle

The angle between the X axis and the straight line.

If there is no input, 0 is regarded.

Pitch space :

Each space in the hole position. A maximum of 11 points can be specified.

Each address to the pitch space is as follows.

Pitch space - 1 : B

Pitch space - 2 : C

Pitch space - 3 : D

Pitch space - 4 : E

Pitch space - 5 : F

Pitch space - 6 : H

Pitch space - 7 : I

Pitch space - 8 : J

Pitch space - 9 : K

Pitch space - 10 : R

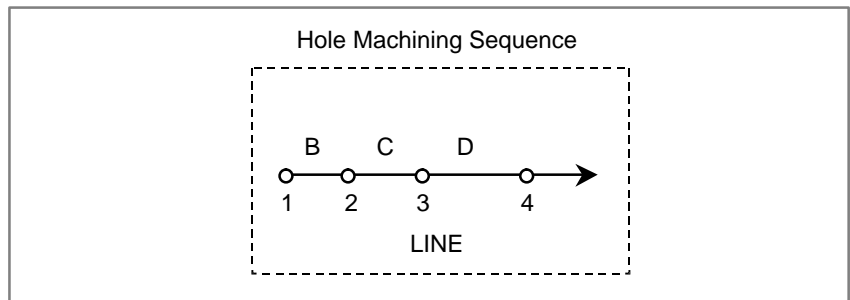
**Q: Pattern continue**

Selection whether to continue entering another hole pattern.

1: End

2: Continue.

- **Grid (G202)**

This is a menu for specifying the holes positions of a grid.
Create ISO code program in the following form.

G202 X_ Y_ U_ V_ I_ J_ K_ L_ Q_ (B_ C_ D_ E_);

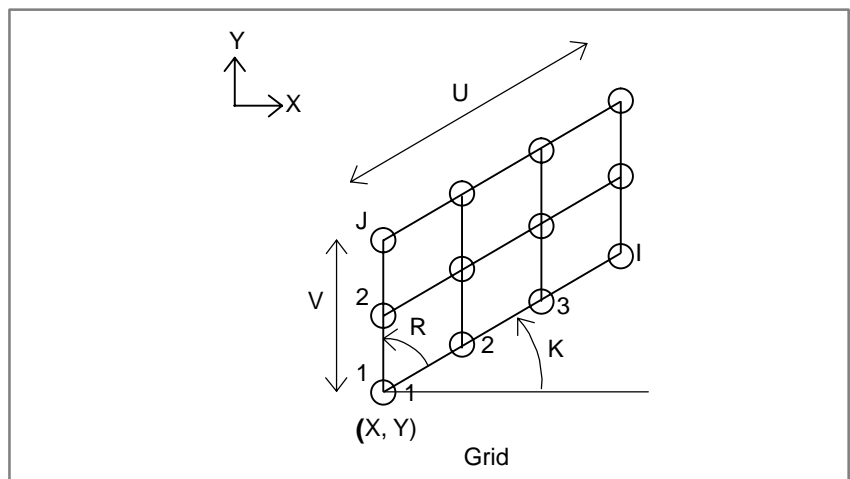
**X: Start point X**

X coordinate of the position of the hole of the first point.
The first point is at the lower left position of the grid.

Y: Start point Y

Y coordinate of the position of the hole of the first point.
The first point is at the lower left position of the grid.

U: U – length

The length in the horizontal direction.

V: V – length

The length in the vertical direction

I: U – number

The number of the holes in the horizontal direction.

J: V – number

The number of the holes in the vertical direction

K: X – U angle

The angle between the line in the horizontal direction and the X axis.
It is considered to be 0 if not input.

R: U – V angle

The acute angle between the line defined by the points and the horizontal direction and vertical direction.
It is considered to be a right angle if not input.

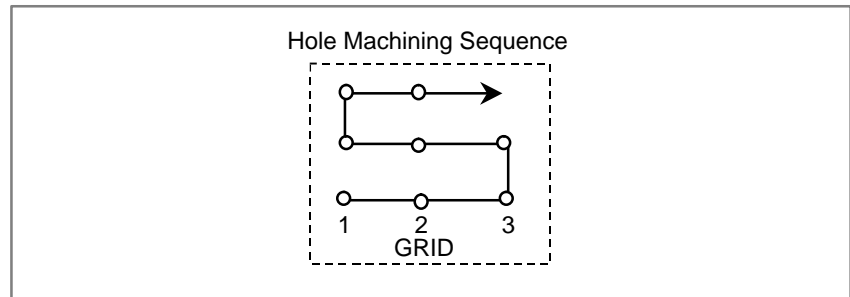

Omit point :

To designate the point to be omitted, input the hole drilling sequence number including its points.

Each address to the number is as follows.

- Omit point – 1 : B
- Omit point – 2 : C
- Omit point – 3 : D
- Omit point – 4 : E

Q: Pattern continue

Selection whether to continue entering another hole pattern.

- 1: End
- 2: Continue.

• **Square (G203)**

This is a menu for specifying the holes positions of a square.

Create ISO code program in the following form.

G203 X__ Y__ U__ V__ I__ J__ K__ R__ Q__ (B__ C__ D__ E__);

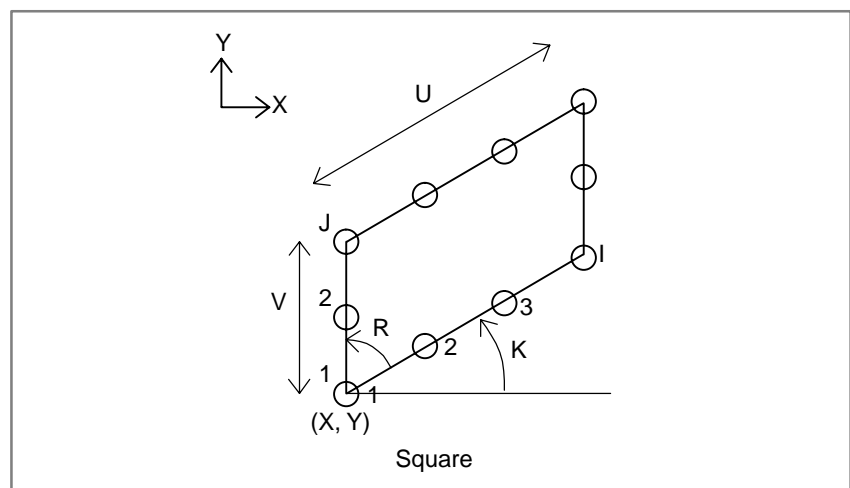

X: Start point X

X coordinate of the position of the hole of the first point.
The first point is at the lower left position of the square.

Y: Start point Y

Y coordinate of the position of the hole of the first point.
The first point is at the lower left position of the square.

U: U – length

The length in the horizontal direction.

- V: V – length
The length in the vertical direction
- I: U – number
The number of the holes in the horizontal direction.
- J: V – number
The number of the holes in the vertical direction
- K: X – U angle
The angle between the line in the horizontal direction and the X axis.
It is considered to be 0 if not input.
- R: U – V angle
The acute angle between the line defined by the points and the horizontal direction and vertical direction.
It is considered to be a right angle if not input.

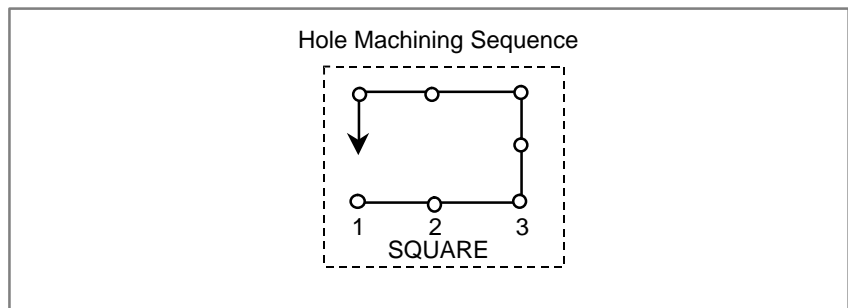

Omit point :

To designate the point to be omitted, input the hole drilling sequence number including its points.

Each address to the number is as follows.

- Omit point – 1 : B
- Omit point – 2 : C
- Omit point – 3 : D
- Omit point – 4 : E

Q: Pattern continue

Selection whether to continue entering another hole pattern.

- 1: End
- 2: Continue.

● **Circle (G204)**

This is a menu for specifying the holes positions of a circle in a same space.

Create ISO code program in the following form.

```
G204 X__ Y__ R__ A__ N__ Q__ (B__ C__ ● ● ● ●);
```

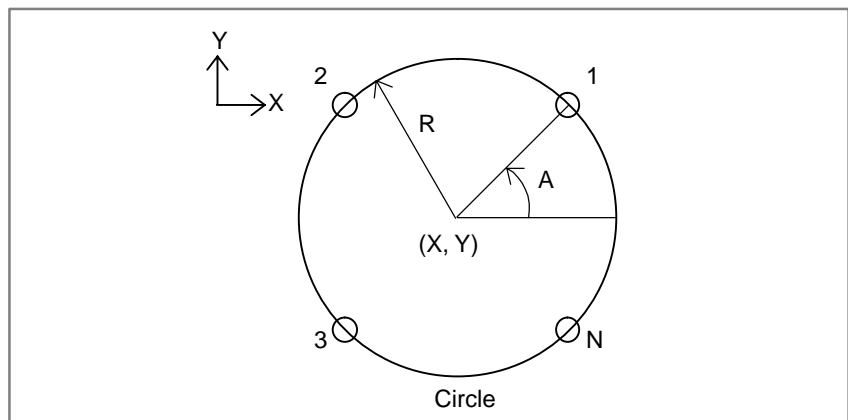

- X: Center point X**
X coordinate of the center of the circle.
- Y: Center point Y**
Y coordinate of the center of the circle.
- R: Radius**
The radius of the circle.
- A: Start angle**
The angle between the segment from the center of the circle to starting point and the X axis.
If there is no input, 0 is regarded and the starting point is considered to be on the X axis.
- N: Holes number**
The total number of holes, including the number of the points to be omitted.

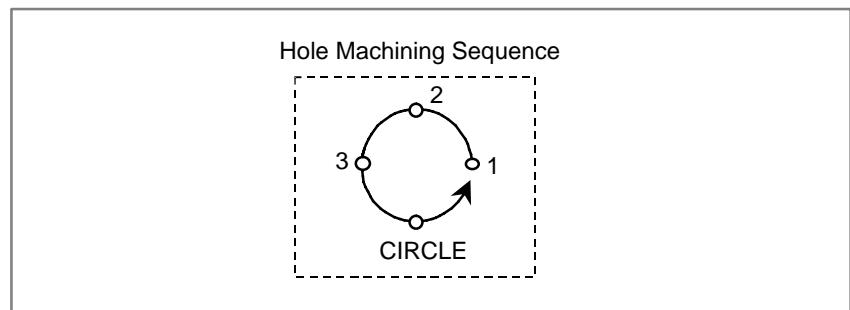

Omit point :

To designate the point to be omitted, input the hole drilling sequence number including its points.

Each address to the number is as follows.

- Omit point - 1 : B
- Omit point - 2 : C
- Omit point - 3 : D
- Omit point - 4 : E

Q: Pattern continue

Selection whether to continue entering another hole pattern.

- 1: End
- 2: Continue

● **Arc (G205)**

This is a menu for specifying the holes positions of a same space arc or a different space arc.

Create ISO code program in the following form.

G205 W__ X__ Y__ R__ A__ N__ T__ Q__ (B__ C__ ●●●●);

W: Space

- 1. Same space arc
- 2. Different space arc

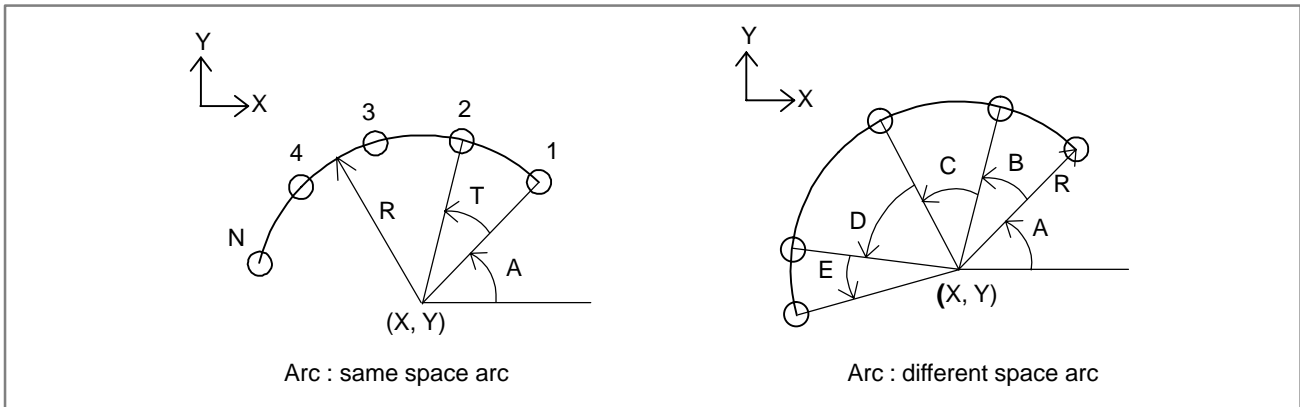

- In the case of Same space arc :
 - X: Center point X
X coordinate of the center of the circle.
 - Y: Center point Y
Y coordinate of the center of the circle.
 - R: Radius
The radius of the circle.
 - A: Start angle
The angle between the segment from the center of the circle to starting point and the X axis.
If there is no input, 0 is regarded and the starting point is considered to be on the X axis.
 - T: Pitch angle
The angle between the segment from the center of the circle to each point.
 - N: Holes number
The total number of holes, including the number of the points to be omitted.
 - Q: Pattern continue
Selection whether to continue entering another hole pattern.
1: End
2: Continue
 - Omit point :
To designate the point to be omitted, input the hole drilling sequence number including its points.
Each address to the number is as follows.
 - Omit point - 1 : B
 - Omit point - 2 : C
 - Omit point - 3 : D
 - Omit point - 4 : E
- In the case of Different space arc :
 - X: Center point X
X coordinate of the center of the circle.
 - Y: Center point Y
Y coordinate of the center of the circle.
 - R: Radius
The radius of the circle.

A: Start angle

The angle between the segment from the center of the circle to starting point and the X axis.

If there is no input, 0 is regarded and the starting point is considered to be on the X axis.

Pitch space :

The angle between the segment from the center of the circle to each point. Input the angles one by one starting from angle 1. A maximum of 11 points can be specified.

Each address to the pitch space is as follows.

Pitch space – 1 : B

Pitch space – 2 : C

Pitch space – 3 : D

Pitch space – 4 : E

Pitch space – 5 : F

Pitch space – 6 : H

Pitch space – 7 : I

Pitch space – 8 : J

Pitch space – 9 : K

Pitch space – 10 : U

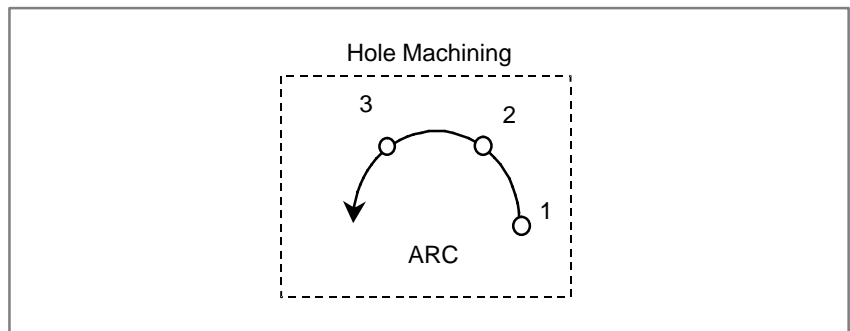
**Q: Pattern continue**

Selection whether to continue entering another hole pattern.

1: End

2: Continue.

Facing

• Square surface (G210)

This is a menu for facing the surface on a square shape plane.
Create ISO code program in the following form.

G210 P__L__Z__B__J__H__F__C__W__X__Y__●●●●●;

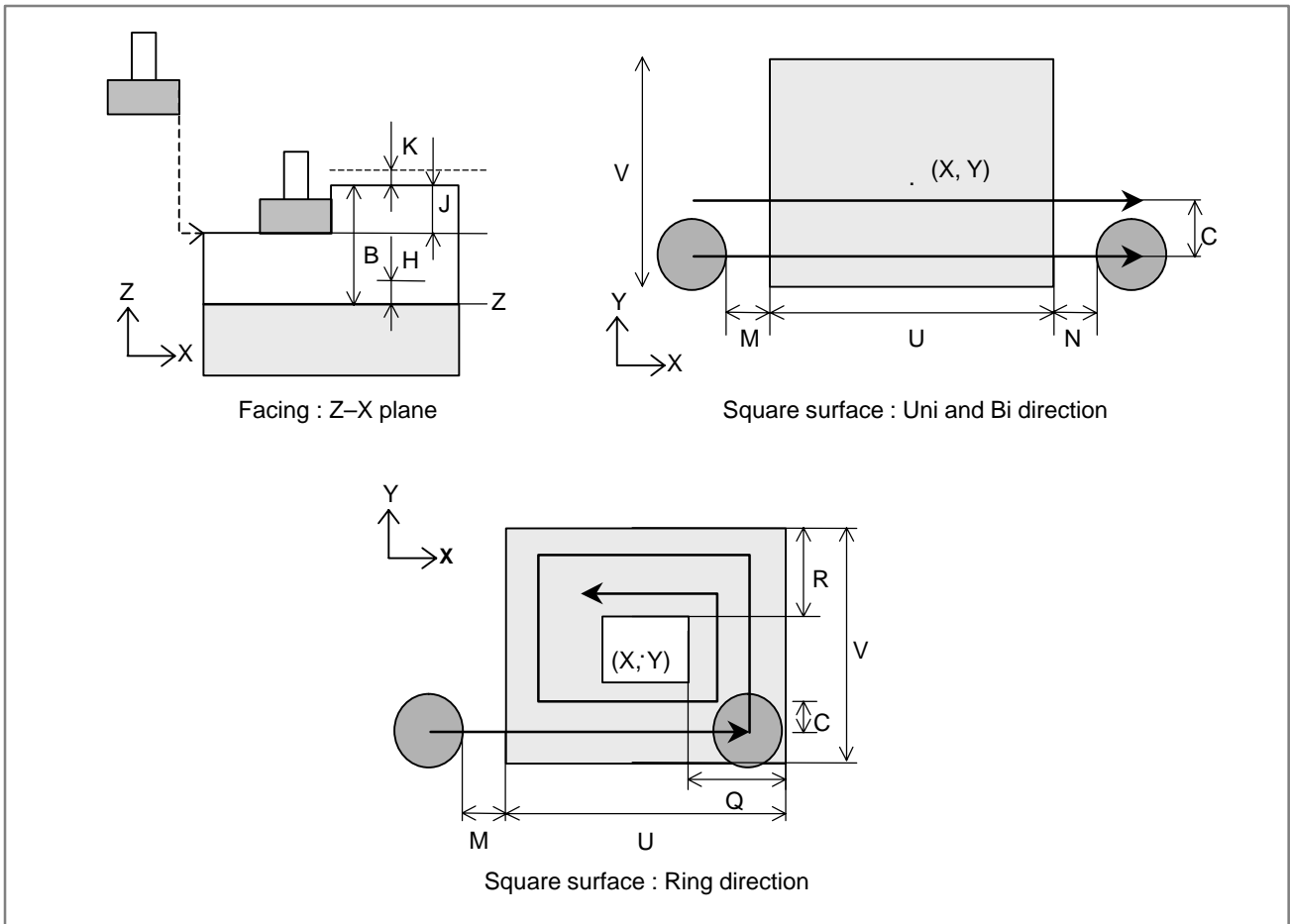

T: Machining process

- 1: Rough cutting
- 2: Finish cutting

Z: End point Z

Z coordinate of the final machined surface

B: Removal depth

The machining allowance in the Z direction of the cutting surface

J: Removal pitch

The machining allowance of one pass for rough cutting in the Z direction.

Rough cutting is done in one pass if not input.

H: Finishing allowance

The machining allowance in the Z direction for finish cutting. This is cut in one pass.

Finish cutting is not done if not input.

F: Feed rate

The feed rate of the tool.

Square surface : Ring direction

C: Cutting width

The machining allowance one of pass in the XY direction.
It is specified a rate (%) of the tool. (less than 70%)

X: Center point X

X coordinate of the center of the square.

Y: Center point Y

Y coordinate of the center of the square.

U: U-length

The horizontal length of the square.

V: V-length

The vertical length of the square.

Q: U-side width

The width of the frame corresponding to side U.

R: V-side width

The width of the frame corresponding to side V.

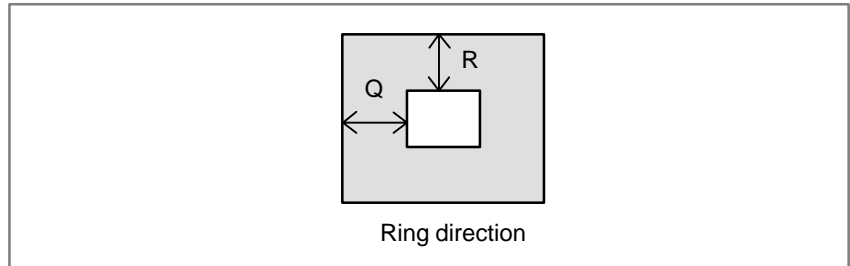

K: Clearance

The amount of clearance for cutting feed in the Z axis at the approach or escape movement. The default data is 3mm.

W: Cutting direction

- 1: Uni-direction
- 2: Bi-direction
- 3: Ring-direction

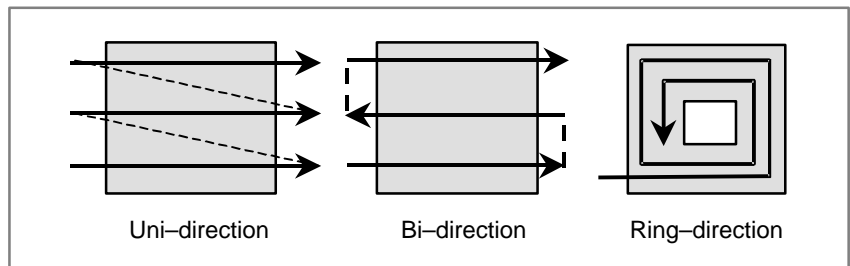

A: Incline angle

The angle between the U side and X axis, when the work is inclined with respect to the X axis. It is considered to be 0 if not input.

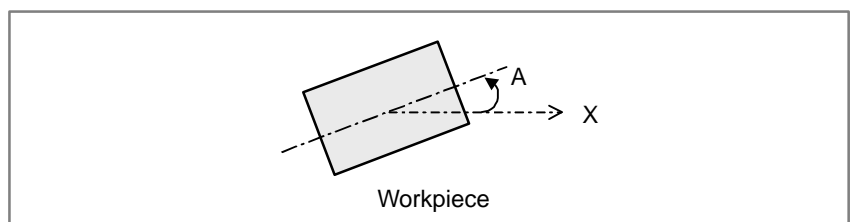

E: Start point

The starting position of the machining (1, 2, 3, 4).
If there is no input, 1 is regarded.

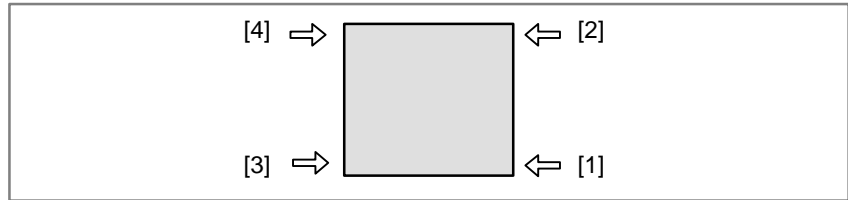

M: Approach gap

The gap between the tool edge in the cutting feed start point and the work.
If there is no input, 5mm is regarded.

N: Escape gap

The gap between the tool edge and the workpiece when the tool moves away the work.
If there is no input, 5mm is regarded.

The following table shows addresses used in arguments in each machining process.

G210	T	Z	B	J	H	F	C	X	Y	U	V	Q	R	L	W	A	E	M	N
Rough (Uni)	#	#	#	&	&	#	#	#	#	#	#	_	_	&	#	&	&	&	&
Finish (Uni)	#	#	_	_	_	#	#	#	#	#	#	_	_	&	#	&	&	&	&
Rough (Bi)	#	#	#	&	&	#	#	#	#	#	#	_	_	&	#	&	&	&	&
Finish (Bi)	#	#	_	_	_	#	#	#	#	#	#	_	_	&	#	&	&	&	&
Rough (Ring)	#	#	#	&	&	#	#	#	#	#	#	#	#	&	#	&	&	&	&
Finish (Ring)	#	#	_	_	_	#	#	#	#	#	#	#	#	&	#	&	&	&	&

: Specify necessarily
& : Specify. If there is no input, default data is specified.
_ : Do not specify.

● Movements :

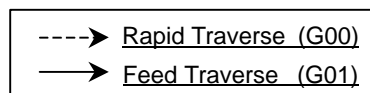

● Uni-direction

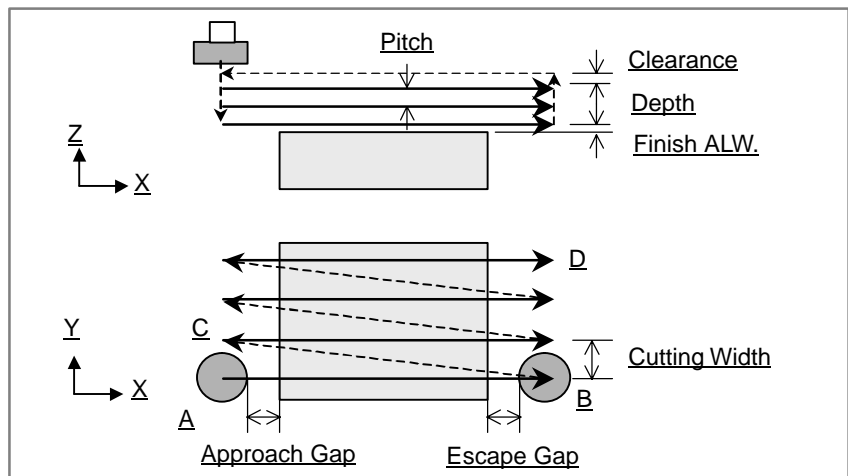

a) In the case of rough cutting

1. Rapid traverse up to the starting point (A).
2. Rapid traverse along the Z axis up to the point equal to (END POINT Z + REMOVAL DEPTH – REMOVAL PITCH)
3. Cutting feed to the opposite side (B) of the starting point.
4. Rise along the Z axis in rapid traverse by an amount of (CLEARANCE + REMOVAL PITCH).
5. Rapid traverse along the X–Y axis up to the next starting point (C).
6. Descent along the Z axis in rapid traverse by an amount of (CLEARANCE + REMOVAL PITCH).
7. 3.– 6. is repeated up to the ending point (D).
8. Rise along the Z axis in rapid traverse by an amount of (CLEARANCE + REMOVAL PITCH).
9. Repeat steps 1. to 8. advancing in the –Z direction, pitch by pitch, up to the point (END POINT Z + FINISHING ALW.).
10. Rise along the Z axis up to the point (END POINT Z + FINISHING ALW. + CLEARANCE).

b) In the case of finish cutting

1. Rapid traverse up to the starting point (A).
2. Rapid traverse along the Z axis up to the point equal to END POINT Z.
3. Cutting feed to the opposite side (B) of the starting point.
4. Rise along the Z axis in rapid traverse by an amount of CLEARANCE.
5. Rapid traverse along the X–Y axis up to the next starting point (B).
6. Descent along the Z axis in rapid traverse up to END POINT Z.
7. 3.– 6. is repeated up to the ending point (D).
8. Rise along the Z axis in rapid traverse by an amount of CLEARANCE.

● Bi – direction

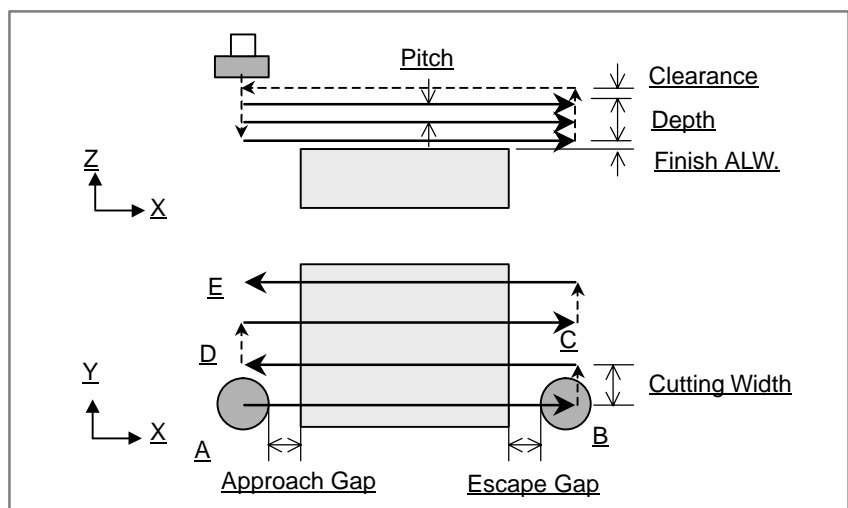

a) In the case of rough cutting

1. Rapid traverse up to the starting point (A).
2. Rapid traverse along the Z axis up to the point equal to (END POINT Z + REMOVAL DEPTH – REMOVAL PITCH)
3. Cutting feed to the other side (B) in the X axis (U direction).
4. Rapid traverse in the Y axis (V direction) to next starting point (C) according to CUTTING WITDH.
5. Cutting feed to the other side (D) in the X axis (U direction).
6. Rapid traverse in the Y axis (V direction) to next starting point according to CUTTING WITDH.
7. 3.– 6. is repeated up to the ending point (D).
8. Rise along the Z axis in rapid traverse by an amount of CLEARANCE.
9. Repeat steps 1. to 8. advancing in the –Z direction, pitch by pitch, up to the point (END POINT Z + FINISHING ALW.).
10. Rise along the Z axis up to the point (END POINT Z + FINISHING ALW. + CLEARANCE).

b) In the case of finish cutting

1. Rapid traverse up to the starting point (A).
2. Rapid traverse along the Z axis up to the point equal to END POINT Z.
3. Cutting feed to the other side (B) in the X axis (U direction).
4. Rapid traverse in the Y axis (V direction) to next starting point (C) according to CUTTING WITDH.
5. Cutting feed to the other side (D) in the X axis (U direction).
6. Rapid traverse in the Y axis (V direction) to next starting point according to CUTTING WITDH.
7. 3.– 6. is repeated up to the ending point (D).
8. Rise along the Z axis in rapid traverse by an amount of CLEARANCE.

● Ring – direction

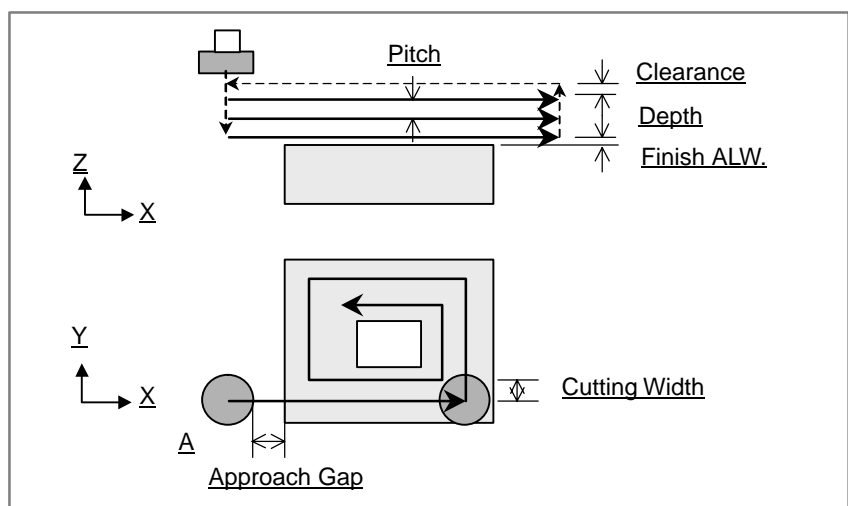

- a) In the case of rough cutting
 1. Rapid traverse up to the starting point (A).
 2. Rapid traverse along the Z axis up to the point equal to (END POINT Z + REMOVAL DEPTH – REMOVAL PITCH)
 3. Cut spirally and finally move in cutting feed by an amount equal to ESCAPE GAP.
 4. Rise along the Z axis in rapid traverse by an amount equal to CLEARANCE.
 5. Repeat steps 1. to 4. advancing in the -Z direction, pitch by pitch, up to the point (END POINT Z + FINISHING ALW.).
 6. Rise along the Z axis up to the point (END POINT Z + FINISHING ALW. + CLEARANCE).
- b) In the case of finish cutting
 1. Rapid traverse up to the starting point (A).
 2. Rapid traverse along the Z axis up to the point equal to END POINT Z.
 3. Cut spirally and finally move in cutting feed by an amount equal to ESCAPE GAP.
 4. Rise along the Z axis in rapid traverse by an amount equal to CLEARANCE.

● **Circle surface (G211)**

This is a menu for facing the surface on a circle shape plane.
Create ISO code program in the following form.

G211 P__L__Z__B__J__H__F__C__W__X__Y__●●●●●;

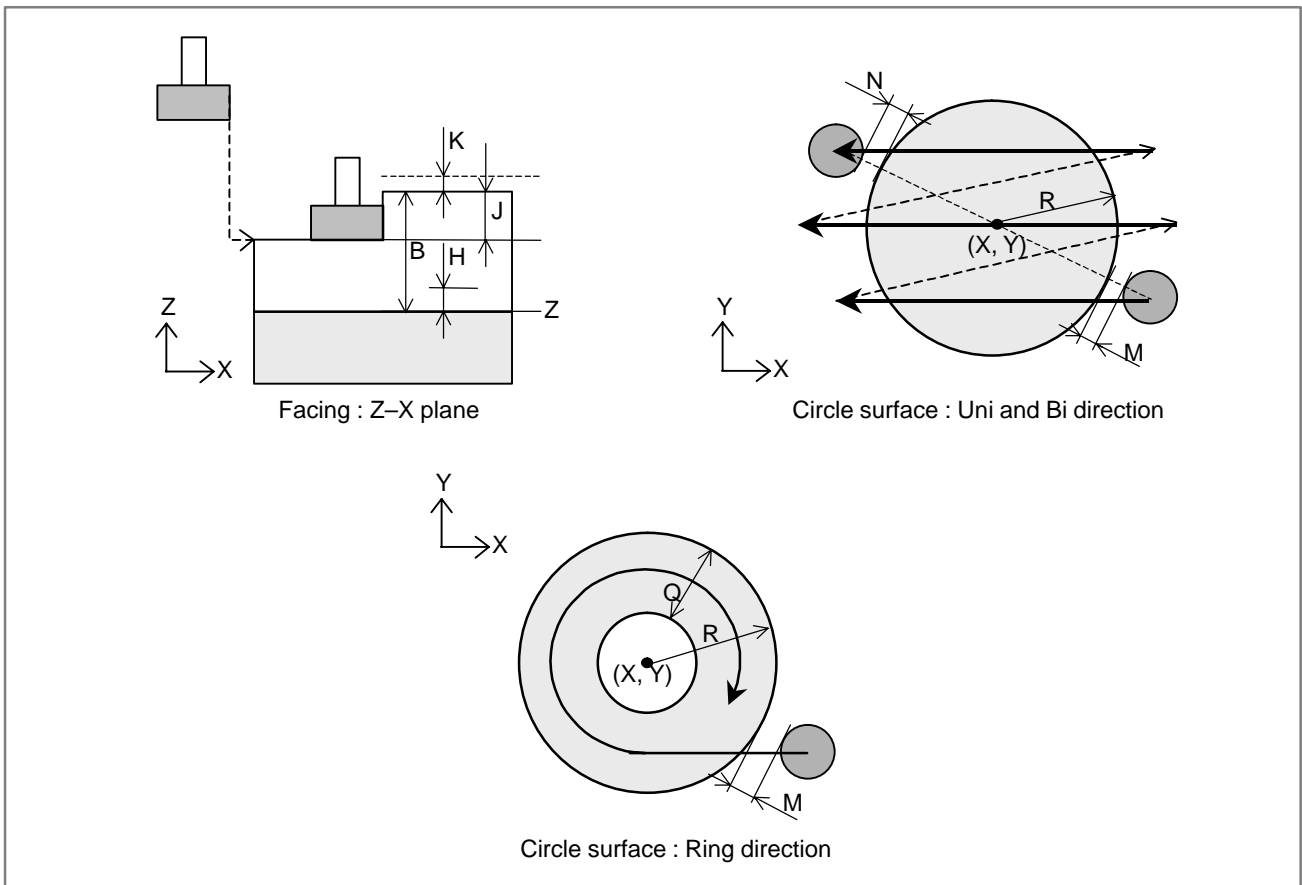

- T: Machining process
 1: Rough cutting
 2: Finish cutting
- Z: End point Z
 Z coordinate of the final machined surface
- B: Removal depth
 The machining allowance in the Z direction of the cutting surface
- J: Removal pitch
 The machining allowance of one pass for rough cutting in the Z direction.
 Rough cutting is done in one pass if not input.
- H: Finishing allowance
 The machining allowance in the Z direction for finish cutting. This is cut in one pass.
 Finish cutting is not done if not input.
- F: Feed rate
 The feed rate of the tool.
- C: Cutting width
 The machining allowance one of pass in the XY direction.
 It is specified a rate (%) of the tool. (less than 70%)
- X: Center point X
 X coordinate of the center of the circular surface.
- Y: Center point Y
 Y coordinate of the center of the circular surface.
- R: Radius
 The radius of the circular surface.
- Q: Ring width
 The width of the ring.
- K: Clearance
 The amount of clearance for cutting feed in the Z axis at the approach or escape movement. The default data is 3mm.
- W: Cutting direction
 1: Uni-direction
 2: Bi-direction
 3: Ring-direction

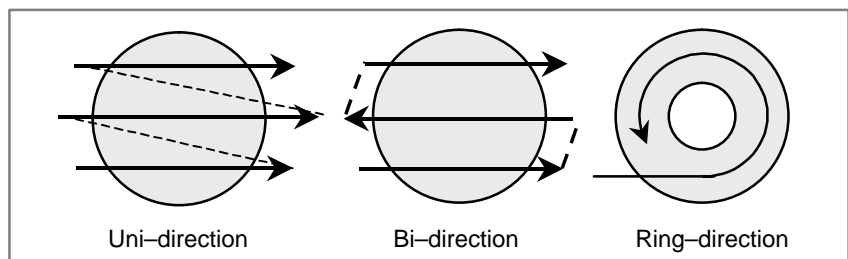

E: Start point

The starting position of the machining (1, 2, 3, 4).
If there is no input, 1 is regarded.

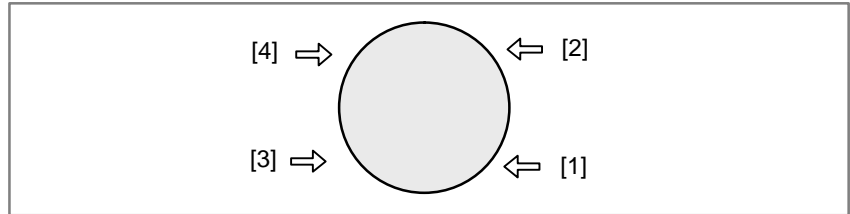

M: Approach gap

The gap between the tool edge in the cutting feed start point and the work.
If there is no input, 5mm is regarded.

N: Escape gap

The gap between the tool edge and the workpiece when the tool moves away the work.
If there is no input, 5mm is regarded.

The following table shows addresses used in arguments in each machining process.

G211	T	Z	B	J	H	F	C	X	Y	R	Q	L	W	E	M	N
Rough (Uni)	#	#	#	&	&	#	#	#	#	#	_	&	#	&	&	&
Finish (Uni)	#	#	_	_	_	#	#	#	#	#	_	&	#	&	&	&
Rough (Bi)	#	#	#	&	&	#	#	#	#	#	_	&	#	&	&	&
Finish (Bi)	#	#	_	_	_	#	#	#	#	#	_	&	#	&	&	&
Rough (Ring)	#	#	#	&	&	#	#	#	#	#	#	&	#	&	&	&
Finish (Ring)	#	#	_	_	_	#	#	#	#	#	#	&	#	&	&	&

#: Specify necessarily

&: Specify. If there is no input, default data is specified.

_: Do not specify.

● **Movements :**

Except for the shape of the circle surface, the machining movements are the same one for the square surface.

Side cutting

• Square side (G220)

This is a menu for cutting the square shape side.
Create ISO code program in the following form.

G220 P__Z__S__I__D__B__J__H__F__E__●●●●●;

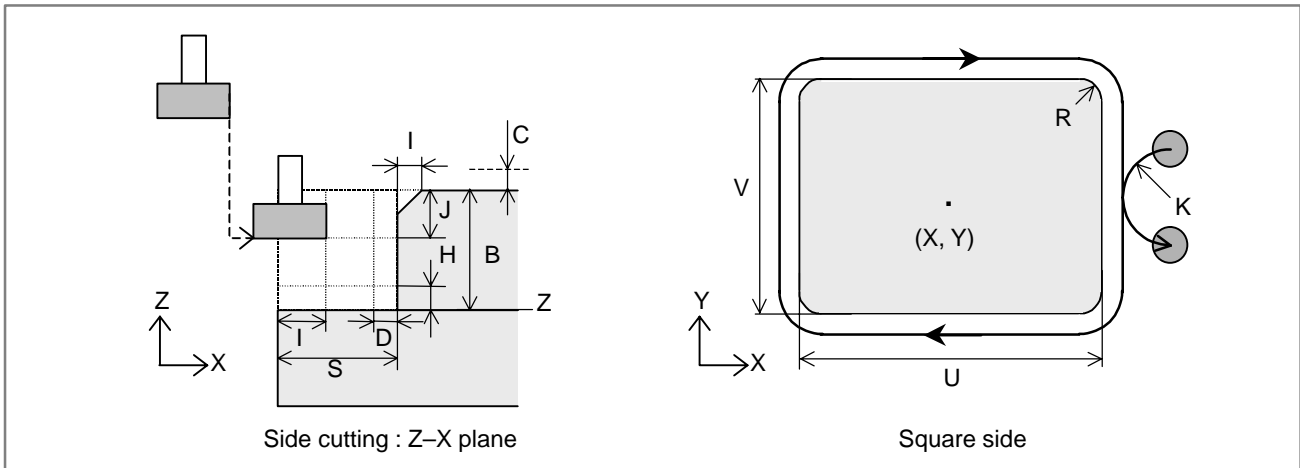

T: Machining process

- 1: Roughing
- 2: Bottom finishing
- 3: Side finishing
- 4: Chamfering

Z: End point Z

Z coordinate of the final machined surface

S: Side removal

The side machining allowance.

I: Side pitch

The side machining allowance of one pass for rough cutting. Rough cutting is done in one pass if not input.

D: Side finish

The side machining allowance of the side finish cutting. This is cut in one pass.

Side finish cutting is not done if not input.

B: Bottom removal

The machining allowance in the Z direction of the cutting surface

J: Bottom pitch

The machining allowance of one pass for rough cutting in the Z direction.

Rough cutting is done in one pass if not input.

H: Bottom finish

The machining allowance of the bottom finish cutting. This is cut in one pass.

Bottom finish cutting is not done if not input.

I: Chamfer removal

The amount of the chamfering.

D: Tool small diameter
The small diameter of chamfer tool.

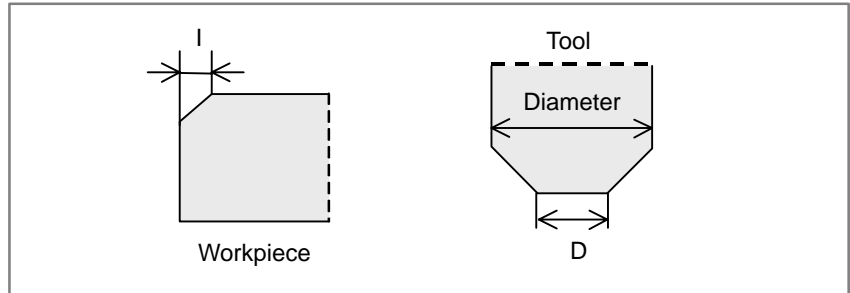

J: Chamfer angle
The tool nose angle of a chamfering tool.

H: Tool out depth
The thrust depth of a chamfering tool.

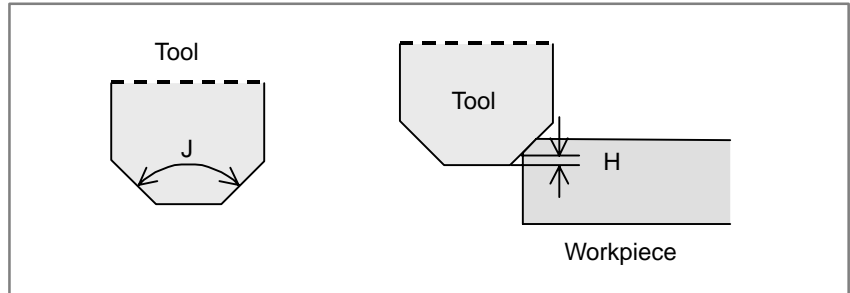

F: The feed rate of the tool.

E: Z_cut feed rate
The cutting feed rate in Zaxis direction from point R.
(Point R = End point Z + Bottom removal + Clearance)

M: The machining shape.
1: Outside
2: Inside

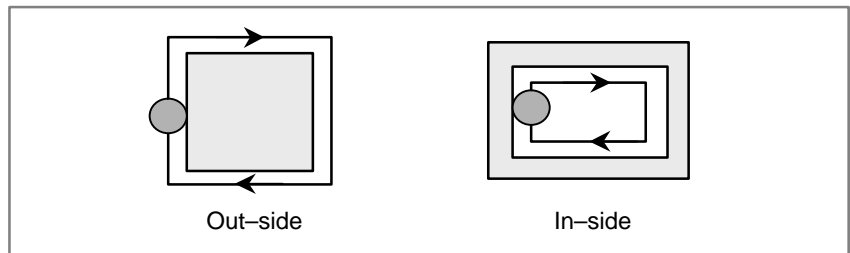

X: Center point X
X coordinate of the center of the square.

Y: Center point Y
Y coordinate of the center of the square.

U: U-length
The horizontal length of the square.

V: V-length
The vertical length of the square.
In the case of Inside, be sure that $U > V$ or $U = V$.
If not, input Incline angle of detail to 90.

C: Clearance

The amount of clearance for cutting feed in the Z axis at the approach or escape movement. The default data is 3mm.

W: Cutting direction

- 1: Down-cut : Rotation of the cutting tool in the forward direction
 - 2: Up-cut : Rotation of the cutting tool in the reverse direction
- If there is no input, 1 is regarded.

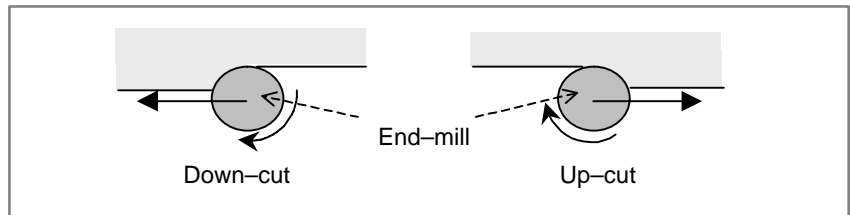

Q: Corner type

- 1: Corner R
 - 2: Corner C
- If there is no input, 1 is regarded.

R: Corner R / C

The amount of radius or chamfer at a corner.

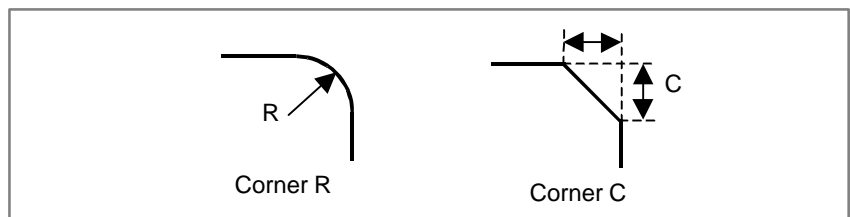

A: Incline angle

The angle between the U side and X axis, when the work is inclined with respect to the X axis. It is considered to be 0 if not input.

K: Approach gap

The gap between the tool edge in the cutting feed start point and the work.
If there is no input, 5mm is regarded.

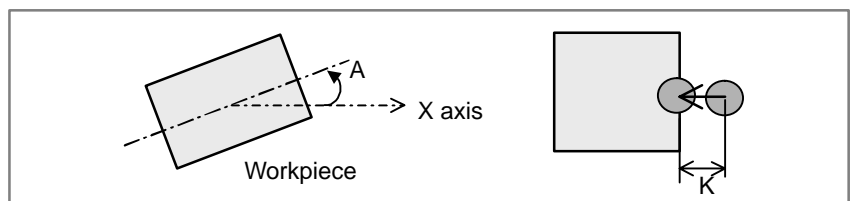

K: Approach / escape

The radius of approach or escape. The movement is performed as a quarter arc.
It is calculated automatically if not input.

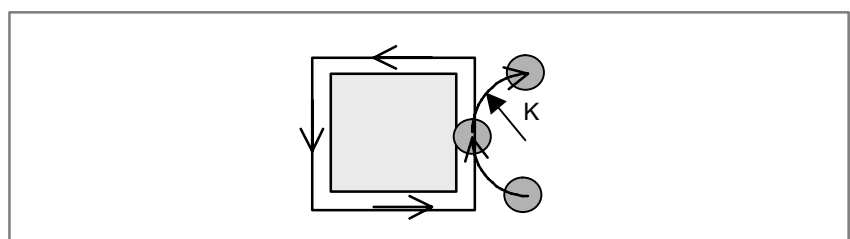

N: Start point

The starting position of the machining (1, 2).
If there is no input, 1 is regarded.

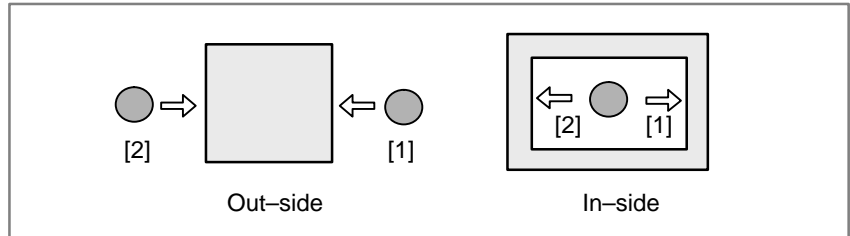

The following table shows addresses used in arguments in each machining process.

G220	T	Z	S	I	D	B	J	H	I	D	J	H	M	F	E	X	Y	U	V
Rough	#	#	#	#	#	#	#	#	_	_	_	_	#	#	#	#	#	#	#
Bottom finish	#	#	#	#	#	#	_	#	_	_	_	_	#	#	#	#	#	#	#
Side finish	#	#	_	_	_	#	#	#	_	_	_	_	#	#	#	#	#	#	#
Chamfer	#	#	_	_	_	#	_	_	#	#	#	#	#	#	#	#	#	#	#

G220	C	W	Q	R	A	K	K	N
Rough	&	&	&	#	&	&	_	&
Bottom finish	&	&	&	#	&	&	_	&
Side finish	&	&	&	#	&	_	&	&
Chamfer	&	&	&	#	&	_	&	&

#: Specify necessarily
&: Specify. If there is no input, default data is specified.
_: Do not specify.

● Movements :

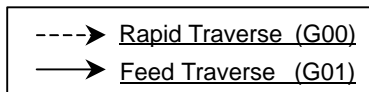

● Outside :

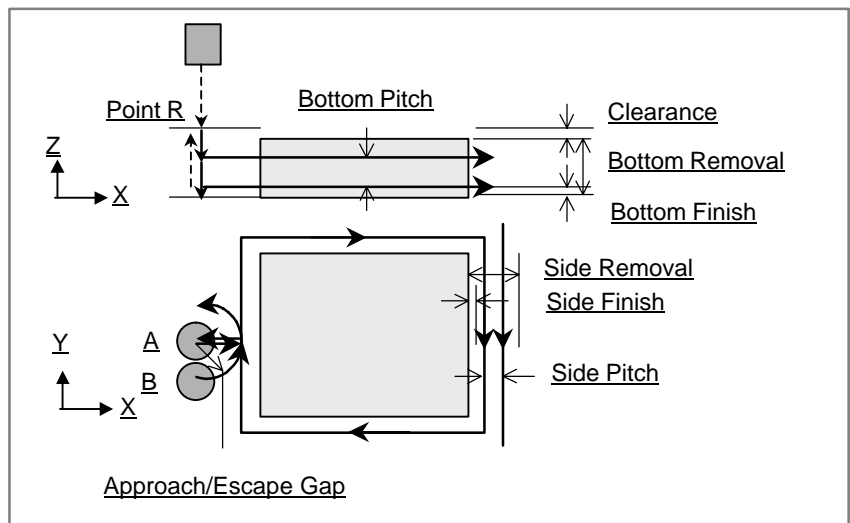

- a) In the case of rough cutting
1. Rapid traverse up to the starting point (A).
 2. Rapid traverse along the Z axis up to point R (END POINT Z + BOTTOM REMOVAL + CLEARANCE)
 3. Descent along the lower Z axis in cutting feed (Z-CUT FEED RATE) by the pitch (BOTTOM PITCH).
 4. Cutting movement (FEED RATE) toward the center by the pitch (SIDE PITCH) .
 5. Side cutting with the cutting width of the pitch (SIDE PITCH).
 6. 4.-5. are repeated up to the point of the distance (SIDE FINISH).
 7. Move away the amount (CLEARANCE) along the Z axis.
 8. Rapid traverse back to the starting point (A).
 9. 3.-8. are repeated up to the point of the distance (BOTTOM FINISH).
 10. Rapid traverse along Z axis up to point R (END POINT Z + BOTTOM REMOVAL + CLEARANCE).
- b) In the case of bottom finish cutting
1. Rapid traverse up to the starting point (A).
 2. Rapid traverse along the Z axis up to point R (END POINT Z + BOTTOM REMOVAL + CLEARANCE)
 3. Descent along the lower Z axis in cutting feed (Z-CUT FEED RATE) up to the point (END POINT Z).
 4. Cutting movement (FEED RATE) toward the center by the pitch (SIDE PITCH) .
 5. Side cutting with the cutting width of the pitch (SIDE PITCH).
 6. 4.-5. are repeated up to the point of the distance (SIDE FINISH).
 7. Move away the amount (CLEARANCE) along the Z axis.
- c) In the case of side finish cutting
1. Rapid traverse up to the starting point (B).
 2. Rapid traverse along the Z axis up to the cutting point + CLEARANCE.
(Cutting point : It is calculated by END POINT Z, BOTTOM REMOVAL, BOTTOM PITCH, CLEARANCE)
 3. Descent along the lower Z axis in cutting feed (Z-CUT FEED RATE) up to the cutting point.
 4. Cut into the workpiece following a circular path.
 5. Cutting of the side finish allowance (SIDE FINISH).
 6. Move away from the workpiece following a circular path after cutting.
 7. Move away the amount (CLEARANCE) along the Z axis.
 8. Rapid traverse back to the starting point (B).
 9. 2.-8. are repeated up to the point (END POINT Z).
 10. Rapid traverse along Z axis up to point R (END POINT Z + BOTTOM REMOVAL + CLEARANCE).

d) In the case of chamfering

1. Rapid traverse up to the starting point (B).
2. Rapid traverse along the Z axis up to the cutting point.
(Cutting point : It is calculated by END POINT Z, BOTTOM REMOVAL, CHAMFER REMOVAL, TOOL SMALL DIA. CHAMFER ANGLE, TOOL OUT DEPTH, CLEARANCE)
3. Cut into the workpiece following a circular path.
4. Cutting of the chamfering allowance (CHAMFER REMOVAL).
5. Move away from the workpiece following a circular path after cutting.
6. Rapid traverse along Z axis up to point R (END POINT Z + BOTTOM REMOVAL + CLEARANCE).

● Inside

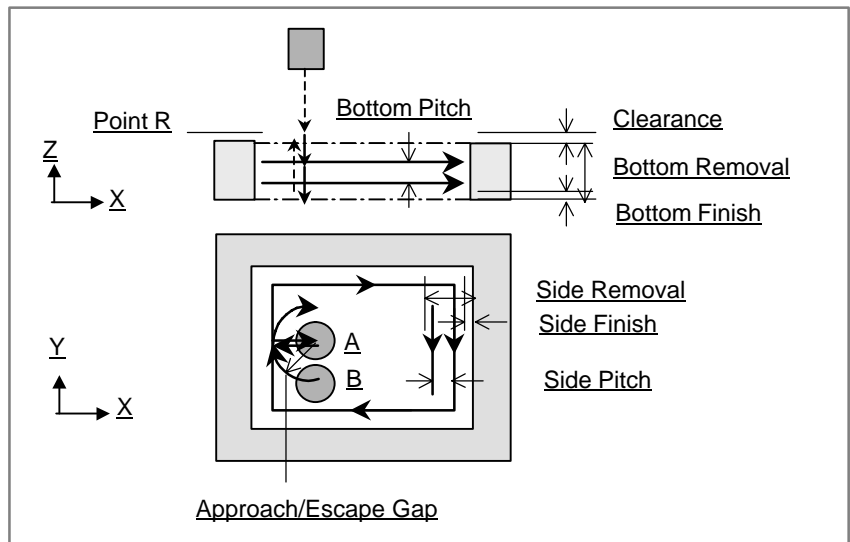

● Movements :

Except for cutting inside, the basic movements are similar to those of the Out-side cutting

● Circle side (G221)

This is a menu for cutting the circle shape side. Create ISO code program in the following form.

```
G221 P__ Z__ S__ I__ D__ B__ J__ H__ F__ E__ ●●●●● ;
```

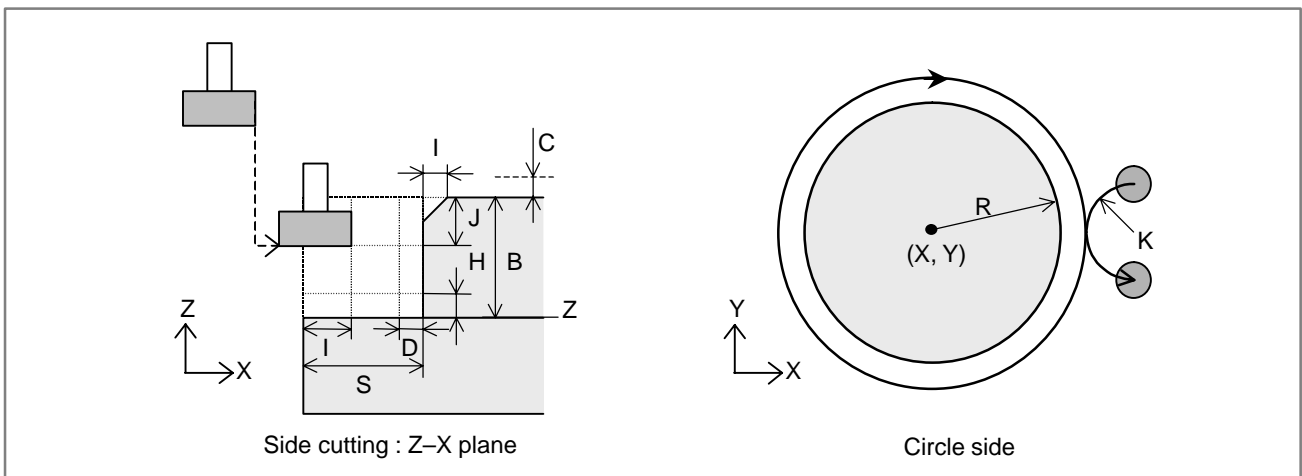

- T: Machining process
 1: Roughing
 2: Bottom finishing
 3: Side finishing
 4: Chamfering
- Z: End point Z
 Z coordinate of the final machined surface
- S: Side removal
 The side machining allowance.
- I: Side pitch
 The side machining allowance of one pass for rough cutting. Rough cutting is done in one pass if not input.
- D: Side finish
 The side machining allowance of the side finish cutting. This is cut in one pass.
 Side finish cutting is not done if not input.
- B: Bottom removal
 The machining allowance in the Z direction of the cutting surface
- J: Bottom pitch
 The machining allowance of one pass for rough cutting in the Z direction.
 Rough cutting is done in one pass if not input.
- H: Bottom finish
 The machining allowance of the bottom finish cutting. This is cut in one pass.
 Bottom finish cutting is not done if not input.
- I: Chamfer removal
 The amount of the chamfering.
- D: Tool small diameter
 The small diameter of chamfer tool.
- J: Chamfer angle
 The tool nose angle of a chamfering tool.
- H: Tool out depth
 The thrust depth of a chamfering tool.
- F: The feed rate of the tool.
- E: Z_cut feed rate
 The cutting feed rate in Zaxis direction from point R.
 (Point R = End point Z + Bottom removal + Clearance)
- M: The machining shape.
 1: Outside
 2: Inside

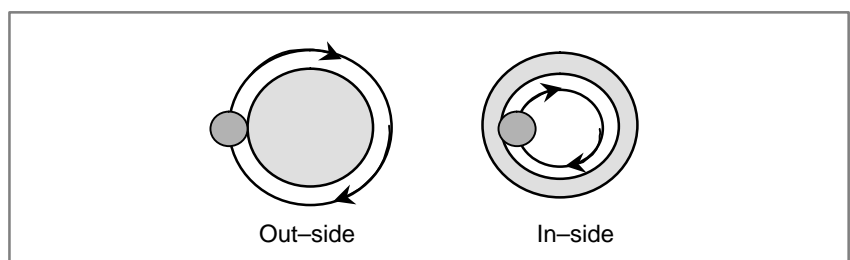

- X: Center point X
X coordinate of the center of the circle.
- Y: Center point Y
Y coordinate of the center of the circle.
- R: Radius
The radius of a circle.
- C: Clearance
The amount of clearance for cutting feed in the Z axis at the approach or escape movement. The default data is 3mm.
- W: Cutting direction
1: Down-cut : Rotation of the cutting tool in the forward direction
2: Up-cut: Rotation of the cutting tool in the reverse direction
If there is no input, 1 is regarded.
- K: Approach gap
The gap between the tool edge in the cutting feed start point and the work.
If there is no input, 5mm is regarded.
- K: Approach / escape
The radius of approach or escape. The movement is performed as a quarter arc.
It is calculated automatically if not input.
- N: Start point
The starting position of the machining (1, 2).
If there is no input, 1 is regarded.

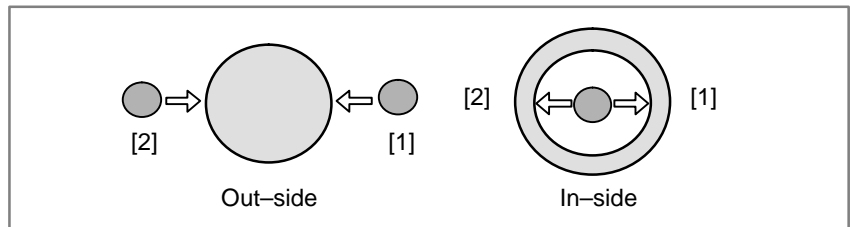

The following table shows addresses used in arguments in each machining process.

G221	T	Z	S	I	D	B	J	H	I	D	J	H	M	F	E	X	Y	R
Rough	#	#	#	#	#	#	#	#	_	_	_	_	#	#	#	#	#	#
Bottom finish	#	#	#	#	#	#	_	#	_	_	_	_	#	#	#	#	#	#
Side finish	#	#	_	_	_	#	#	#	_	_	_	_	#	#	#	#	#	#
Chamfer	#	#	_	_	_	#	_	_	#	#	#	#	#	#	#	#	#	#

G221	C	W	K	K	N
Rough	&	&	&	_	&
Bottom finish	&	&	&	_	&
Side finish	&	&	_	&	&
Chamfer	&	&	_	&	&

#: Specify necessarily
&: Specify. If there is no input, default data is specified.
_: Do not specify.

- Movements :

Except for the shape of the circle, the basic movements are similar to those of Square side.

- Track side (G222)

This is a menu for cutting the track shape side.

Create ISO code program in the following form.

G222 P__ Z__ S__ I__ D__ B__ J__ H__ F__ E__ ●●●●● ;

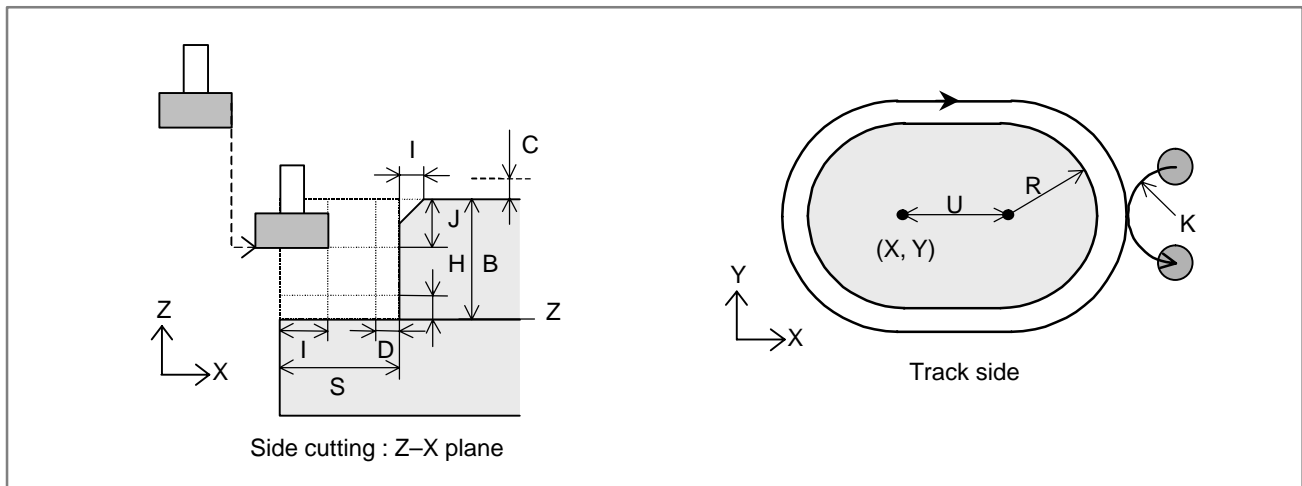

T: Machining process

- 1: Roughing
- 2: Bottom finishing
- 3: Side finishing
- 4: Chamfering

Z: End point Z

Z coordinate of the final machined surface

S: Side removal

The side machining allowance.

I: Side pitch

The side machining allowance of one pass for rough cutting. Rough cutting is done in one pass if not input.

D: Side finish

The side machining allowance of the side finish cutting. This is cut in one pass.

Side finish cutting is not done if not input.

B: Bottom removal

The machining allowance in the Z direction of the cutting surface

J: Bottom pitch

The machining allowance of one pass for rough cutting in the Z direction.

Rough cutting is done in one pass if not input.

H: Bottom finish

The machining allowance of the bottom finish cutting. This is cut in one pass.

Bottom finish cutting is not done if not input.

I: Chamfer removal

The amount of the chamfering.

D: Tool small diameter

The small diameter of chamfer tool.

- J: Chamfer angle
The tool nose angle of a chamfering tool.
- H: Tool out depth
The thrust depth of a chamfering tool.
- F: The feed rate of the tool.
- E: Z_{cut} feed rate
The cutting feed rate in Zaxis direction from point R.
(Point R = End point Z + Bottom removal + Clearance)
- M: The machining shape.
 - 1: Outside
 - 2: Inside

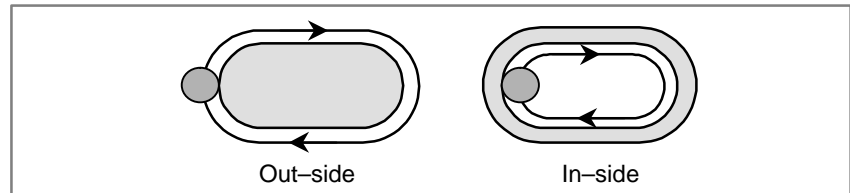

- X: Center point X
X coordinate of the center of the left arc.
- Y: Center point Y
Y coordinate of the center of the left arc.
- U: Center distance
The distance between the centers of the two arcs.
- R: Radius
The radius of a circle.
- C: Clearance
The amount of clearance for cutting feed in the Z axis at the approach or escape movement. The default data is 3mm.
- W: Cutting direction
 - 1: Down-cut : Rotation of the cutting tool in the forward direction
 - 2: Up-cut : Rotation of the cutting tool in the reverse direction
 If there is no input, 1 is regarded.
- A: Incline angle
The angle between the U side and X axis, when the work is inclined with respect to the X axis. It is considered to be 0 if not input.
- K: Approach gap
The gap between the tool edge in the cutting feed start point and the work.
If there is no input, 5mm is regarded.
- K: Approach / escape
The radius of approach or escape. The movement is performed as a quarter arc.
It is calculated automatically if not input.
- N: Start point
The starting position of the machining (1, 2).
If there is no input, 1 is regarded.

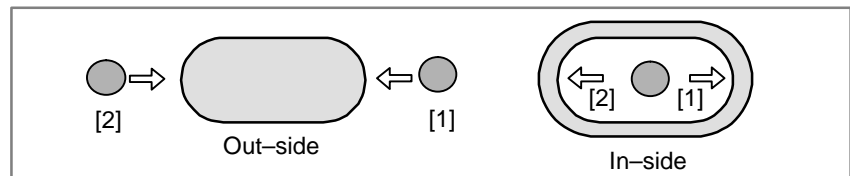

The following table shows addresses used in arguments in each machining process..

G222	T	Z	S	I	D	B	J	H	I	D	J	H	M	F	E	X	Y	U	R
Rough	#	#	#	#	#	#	#	#	_	_	_	_	#	#	#	#	#	#	#
Bottom finish	#	#	#	#	#	#	_	#	_	_	_	_	#	#	#	#	#	#	#
Side finish	#	#	_	_	_	#	#	#	_	_	_	_	#	#	#	#	#	#	#
Chamfer	#	#	_	_	_	#	_	_	#	#	#	#	#	#	#	#	#	#	#

G222	C	W	A	K	K	N
Rough	&	&	&	&	_	&
Bottom finish	&	&	&	&	_	&
Side finish	&	&	&	_	&	&
Chamfer	&	&	&	_	&	&

#: Specify necessarily
 &: Specify. If there is no input, default data is specified.
 _: Do not specify.

- Movements :
 Except for the shape of the track, the basic movements are similar to those of Square side.

● One side (G223)

This is a menu for cutting the one side only.
 Create ISO code program in the following form.

G223 P__ Z__ S__ I__ D__ B__ J__ H__ F__ E__ ●●●●● ;

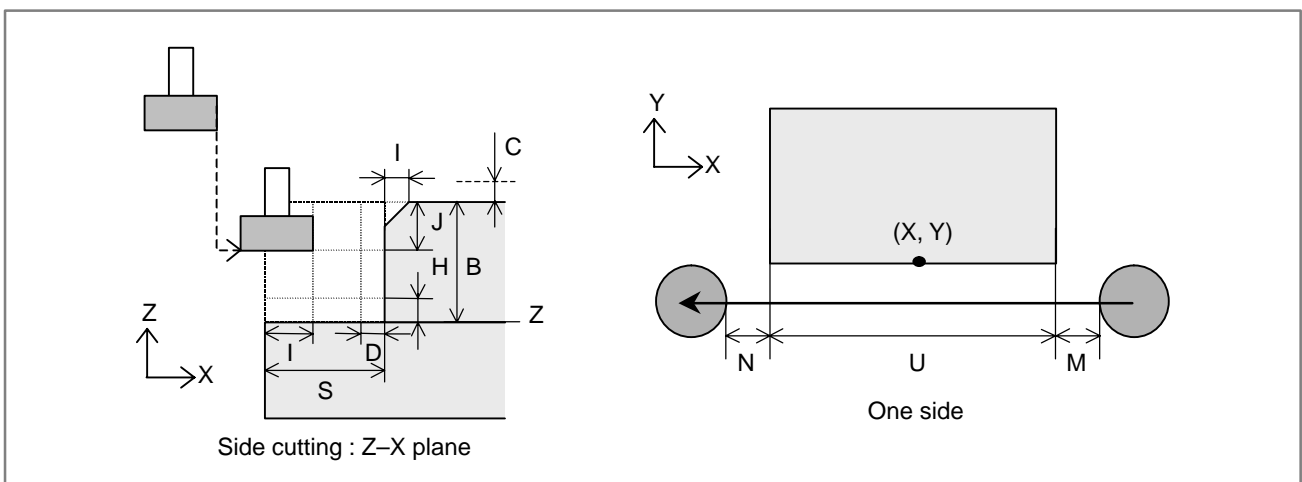

- T: Machining process
 - 1: Roughing
 - 2: Bottom finishing
 - 3: Side finishing
 - 4: Chamfering
- Z: End point Z
 Z coordinate of the final machined surface
- S: Side removal
 The side machining allowance.

- I: Side pitch
The side machining allowance of one pass for rough cutting. Rough cutting is done in one pass if not input.
- D: Side finish
The side machining allowance of the side finish cutting. This is cut in one pass.
Side finish cutting is not done if not input.
- B: Bottom removal
The machining allowance in the Z direction of the cutting surface
- J: Bottom pitch
The machining allowance of one pass for rough cutting in the Z direction.
Rough cutting is done in one pass if not input.
- H: Bottom finish
The machining allowance of the bottom finish cutting. This is cut in one pass.
Bottom finish cutting is not done if not input.
- I: Chamfer removal
The amount of the chamfering.
- D: Tool small diameter
The small diameter of chamfer tool.
- J: Chamfer angle
The tool nose angle of a chamfering tool.
- H: Tool out depth
The thrust depth of a chamfering tool.
- F: The feed rate of the tool.
- X: Center point X
X coordinate of the center of the cutting surface after cutting.
- Y: Center point Y
Y coordinate of the center of the cutting surface after cutting.
- U: U-length
The length of the workpiece in the cutting surface.
- C: Clearance
The amount of clearance for cutting feed in the Z axis at the approach or escape movement. The default data is 3mm.

W: Cutting direction

- 1, 4: Down-cut : Rotation of the cutting tool in the forward direction
 - 2, 3: Up-cut : Rotation of the cutting tool in the reverse direction
- If there is no input, 1 is regarded.

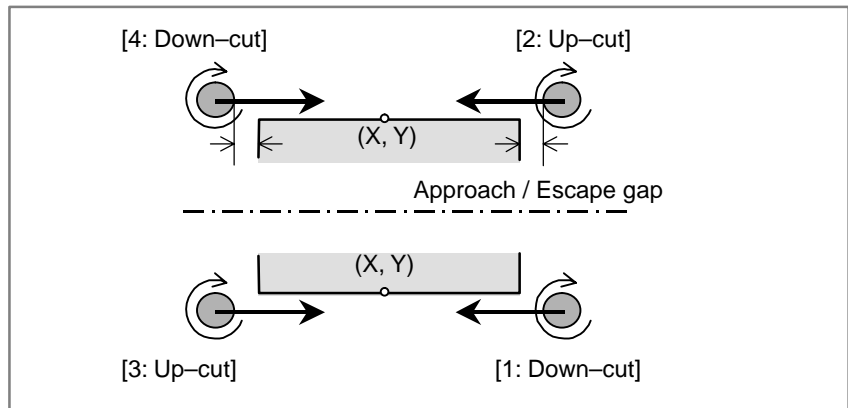

A: Incline angle

The angle between the U side and X axis, when the work is inclined with respect to the X axis. It is considered to be 0 if not input.

M: Approach gap

The gap between the tool edge in the machining start point and the workpiece edge.

If there is no input, 5mm is regarded.

N: Escape gap

The gap between the tool edge when the tool moves away from the workpiece after cutting and the workpiece edge. If there is no input, 5mm is regarded.

The following table shows addresses used in arguments in each machining process.

G223	T	Z	S	I	D	B	J	H	I	D	J	H	F	X	Y	U	C	W	A	M	N
Rough	#	#	#	#	#	#	#	#	_	_	_	_	#	#	#	#	&	&	&	&	&
Bottom finish	#	#	#	#	#	#	_	#	_	_	_	_	#	#	#	#	&	&	&	&	&
Side finish	#	#	_	_	_	#	#	#	_	_	_	_	#	#	#	#	&	&	&	&	&
Chamfer	#	#	_	_	_	#	_	_	#	#	#	#	#	#	#	#	&	&	&	&	&

#: Specify necessarily

&: Specify. If there is no input, default data is specified.

_: Do not specify.

- Movements :

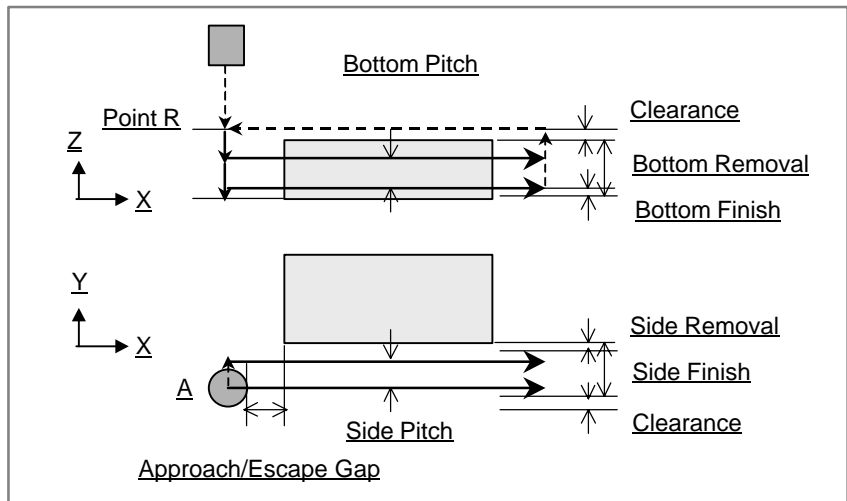
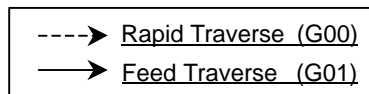

a) In the case of rough cutting

1. Rapid traverse up to the starting point (A).
2. Rapid traverse along the Z axis up to point R (END POINT Z + BOTTOM REMOVAL + CLEARANCE)
3. Rapid traverse toward one side by the pitch (SIDE PITCH).
4. Descent along the lower Z axis in cutting feed (Z-CUT FEED RATE) by the pitch (BOTTOM PITCH).
5. Side cutting with the cutting width of the pitch (SIDE PITCH).
6. Rise to point R in rapid traverse along the Z axis.
7. Rapid traverse back to the starting point (A).
8. 3.-7. are repeated up to the point of the distance (SIDE FINISH).
9. 3.-8. are repeated up to the point of the distance (BOTTOM FINISH).
10. Rapid traverse along Z axis up to point R (END POINT Z + BOTTOM REMOVAL + CLEARANCE).

b) In the case of bottom finish cutting

1. Rapid traverse up to the starting point (A).
2. Rapid traverse along the Z axis up to point R (END POINT Z + BOTTOM REMOVAL + CLEARANCE)
3. Rapid traverse toward one side by the pitch (SIDE PITCH).
4. Descent along the lower Z axis in cutting feed (Z-CUT FEED RATE) up to the end point (END POINT Z).
5. Side cutting with the cutting width of the pitch (SIDE PITCH).
6. 4.-5. are repeated up to the point of the distance (SIDE FINISH).
7. Move away from the workpiece after cutting in Z axis by a clearance.
8. Rapid traverse along Z axis up to point R (END POINT Z + BOTTOM REMOVAL + CLEARANCE).

- c) In the case of side finish cutting
1. Rapid traverse up to the starting point (A).
 2. Rapid traverse along the Z axis up to point R (END POINT Z + BOTTOM REMOVAL + CLEARANCE).
 3. Rapid traverse toward one side by the allowance (SIDE FINISH).
 4. Descent along the lower Z axis in cutting feed (Z-CUT FEED RATE) with the pitch (BOTTOM PITCH).
 5. Side cutting with the cutting width of the allowance (SIDE FINISH).
 6. Move away from the workpiece after cutting
 7. 3.-6. are repeated up to the point (END POINT Z).
 8. Rapid traverse along Z axis up to point R (END POINT Z + BOTTOM REMOVAL + CLEARANCE).
- d) In the case of chamfering
1. Rapid traverse up to the starting point (A).
 2. Rapid traverse along the Z axis up to the cutting point.
(Cutting point : It is calculated by END POINT Z, BOTTOM REMOVAL, CHAMFER REMOVAL, TOOL SMALL DIA. CHAMFER ANGLE, TOOL OUT DEPTH, CLEARANCE)
 3. Cut into the workpiece following a circular path.
 4. Cutting of the chamfering allowance (CHAMFER REMOVAL).
 5. Move away from the workpiece following a circular path after cutting.
 6. Rapid traverse along Z axis up to point R (END POINT Z + BOTTOM REMOVAL + CLEARANCE).

Pocketing

● **Square pocket (G230)**

This is a menu for pocketing the square shape.
Create ISO code program in the following form.

```
G230 P__ Z__ B__ J__ H__ F__ C__ W__ X__ Y__ ●●●●● ;
```

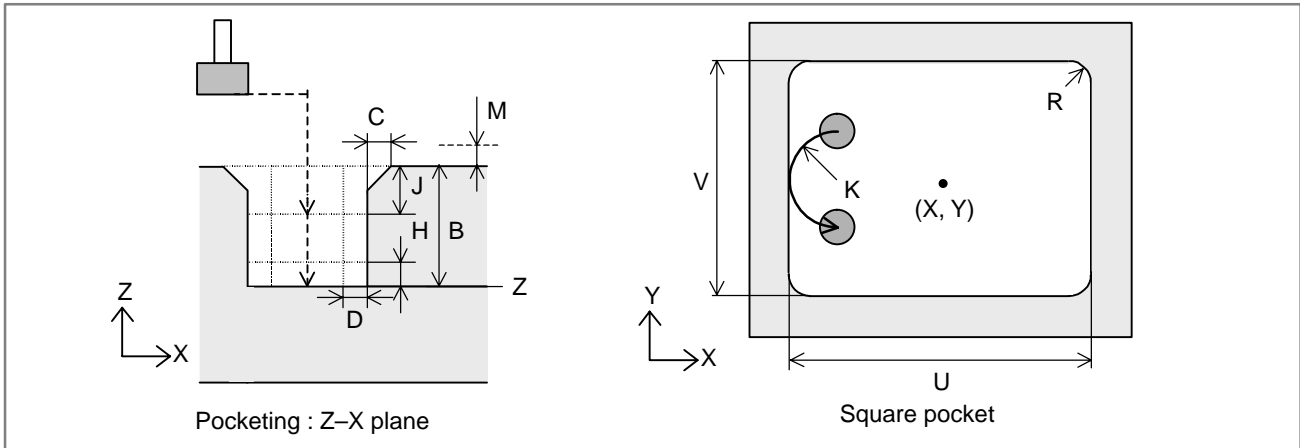

T: Machining process

- 1: Roughing
- 2: Bottom finishing
- 3: Side finishing
- 4: Chamfering
- 5: Drilling

Z: End point Z

Z coordinate of the final machined surface

B: Removal depth

The depth of the pocket.

J: Removal pitch

The machining allowance of one pass for rough cutting in the Z direction.

Rough cutting is done in one pass if not input.

H: Bottom finish

The bottom machining allowance for bottom finish cutting. This is cut in one pass.

Bottom finish cutting is not done if not input.

D: Side finish

The side machining allowance for side finish cutting.

Side finish cutting is not done if not input.

C: Chamfer removal

The amount of the chamfering.

D: Tool small diameter

The small diameter of chamfer tool.

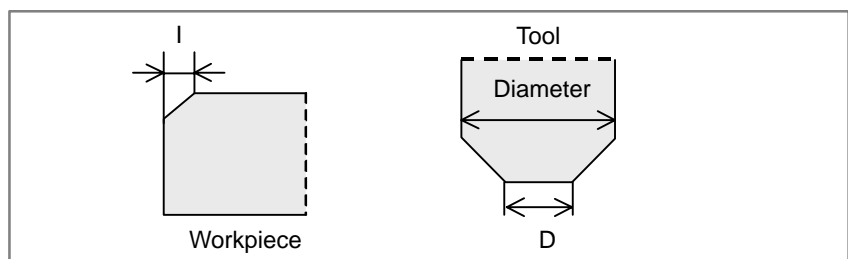

- J: Chamfer angle
The tool nose angle of a chamfering tool.
- H: Tool out depth
The thrust depth of a chamfering tool.

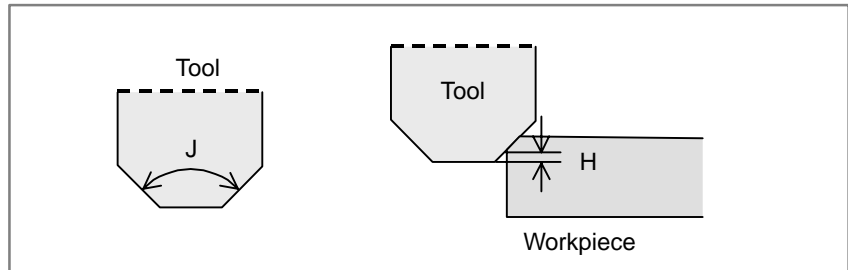

- F: The feed rate of the tool.
- E: Z_{cut} feed rate
The cutting feed rate in Zaxis direction from point R.
(Point R = End point Z + Bottom removal + Clearance)
- C: Cutting width
The machining allowance of one pass in the XY direction.
It is specified a rate (%) of the tool. (less than 70%)
- X: Center point X
X coordinate of the center of the square.
- Y: Center point Y
Y coordinate of the center of the square.
- U: U-length
The horizontal length of the square.
- V: V-length
The vertical length of the square.
- S: Cycle select
Select the drilling cycle for pre-hole
1: G81 (Normal drilling)
2: G83 (Peck drilling)
3: G73 (High-speed peck drilling)
- Q: Pitch depth
The depth of cut for each cutting cycle.
It is used for G83 (S:2) and G73 (S:3).
- M: Clearance
The amount of clearance for cutting feed in the Z axis at the approach or escape movement. The default data is 3mm.
- W: Cutting direction
1: Down-cut : Rotation of the cutting tool in the forward direction
2: Up-cut : Rotation of the cutting tool in the reverse direction
If there is no input, 1 is regarded.
- R: Corner R
The amount of radius at a corner.

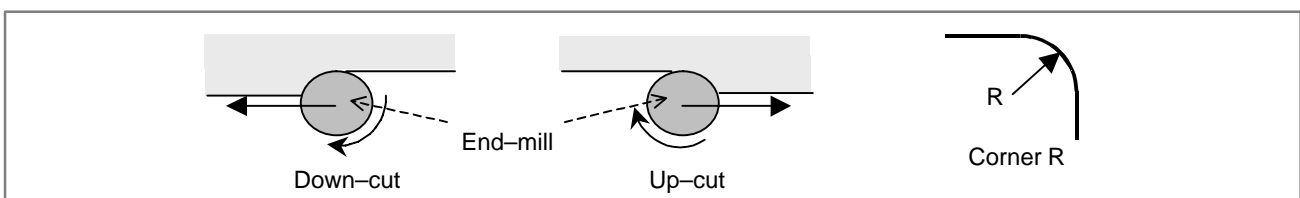

K: Approach / escape

The radius of approach or escape. The movement is performed as a quarter arc.

It is calculated automatically if not input.

A: Incline angle

The angle between the U side and X axis, when the work is inclined with respect to the X axis. It is considered to be 0 if not input.

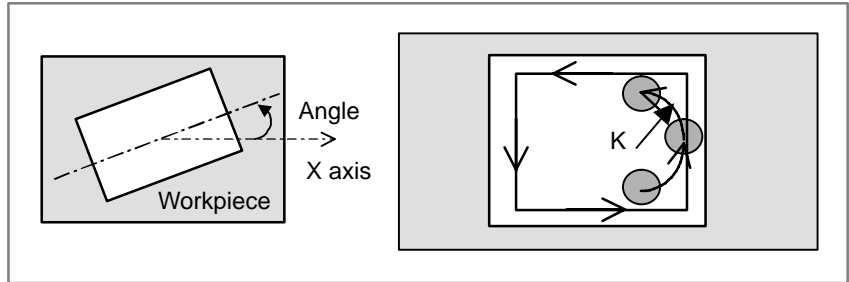

The following table shows addresses used in arguments in each machining process.

G230	T	Z	B	J	H	D	C	D	J	H	C	F	E	X	Y	U	V
Rough	#	#	#	#	#	#	_	_	_	_	#	#	#	#	#	#	#
Bottom finish	#	#	#	_	#	#	_	_	_	_	#	#	#	#	#	#	#
Side finish	#	#	#	#	#	_	_	_	_	_	_	#	#	#	#	#	#
Chamfer	#	#	#	_	_	_	#	#	#	#	_	#	#	#	#	#	#
Drill	#	#	#	_	_	_	_	_	_	_	_	#	_	#	#	#	#

G230	S	Q	M	W	R	K	A
Rough	_	_	&	&	&	_	&
Bottom finish	_	_	&	&	&	_	&
Side finish	_	_	&	&	&	&	&
Chamfer	_	_	&	&	&	&	&
Drill	#	#	&	_	_	_	&

#: Specify necessarily

&: Specify. If there is no input, default data is specified.

_ : Do not specify.

- Movements :

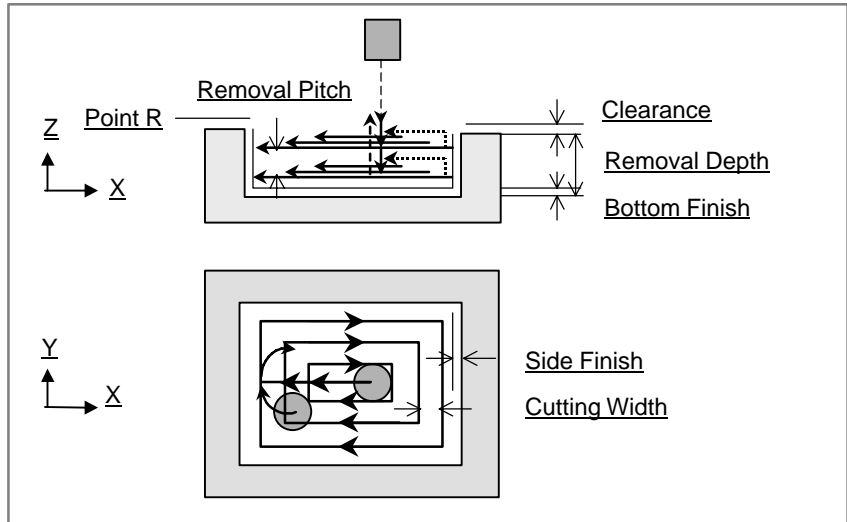
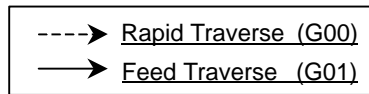

a) In the case of rough cutting

1. Rapid traverse up to the starting point.
2. Rapid traverse along the Z axis up to point R (END POINT Z + REMOVAL DEPTH + CLEARANCE)
3. Descent along the lower Z axis in cutting feed (Z-CUT FEED RATE) by the pitch (REMOVAL PITCH).
4. Cutting from the inside to the outside using the same cutting width (CUTTING WIDTH) in cutting feed (FEED RATE).
5. After cutting, side finish allowance (SIDE FINISH) remains.
6. Rapid traverse along Z axis up to point R
7. Rapid traverse back to the starting point (A).
8. Rapid traverse down to the cutting surface + clearance (CLEARANCE) along Z axis.
9. Advance in -Z axis by the pitch (REMOVAL PITCH) and repeat steps 3. to 8. up to the point of the distance (SIDE FINISH).
10. Rapid traverse along Z axis up to point R.

b) In the case of bottom finish cutting

1. Rapid traverse up to the starting point.
2. Rapid traverse along the Z axis up to point R (END POINT Z + REMOVAL DEPTH + CLEARANCE)
3. Descent along the lower Z axis in cutting feed (Z-CUT FEED RATE) up to the end point (END POINT Z).
4. Cutting from the inside to the outside using the same cutting width (CUTTING WIDTH) in cutting feed (FEED RATE).
5. After cutting, side finish allowance (SIDE FINISH) remains.
6. Rapid traverse along Z axis up to point R

c) In the case of side finish cutting

1. Rapid traverse up to the starting point.

2. Rapid traverse along the Z axis up to the cutting point.
(Cutting point : It is calculated by END POINT Z, REMOVAL DEPTH, REMOVAL PITCH, CLEARANCE)
 3. Cut into the workpiece following a circular path.
 4. Cutting of the side finish allowance (SIDE FINISH).
 5. Move away from the workpiece following a circular path after cutting.
 6. 3.-5. are repeated up to the point (END POINT Z) by the pitch (REMOVAL PITCH).
 7. Rapid traverse along Z axis up to point R (END POINT Z + REMOVAL DEPTH + CLEARANCE).
- d) In the case of chamfering
1. Rapid traverse up to the starting point.
 2. Rapid traverse along the Z axis up to the cutting point.
(Cutting point : It is calculated by END POINT Z, REMOVAL DEPTH, CHAMFER REMOVAL, TOOL SMALL DIA., CHAMFER ANGLE, TOOL OUT DEPTH, CLEARANCE)
 3. Cut into the workpiece following a circular path.
 4. Cutting of the chamfering allowance (CHAMFER REMOVAL).
 5. Move away from the workpiece following a circular path after cutting.
 6. Rapid traverse along Z axis up to point R (END POINT Z + REMOVAL DEPTH + CLEARANCE).
- e) In the case of drilling for pre-hole
1. Rapid traverse up to the starting point.
 2. Rapid traverse along the lower Z axis up to the point R.
 3. Drilling along Z axis up to the point Z (END POINT Z).
 4. Rapid traverse along Z axis up to point R level (END POINT Z + REMOVAL DEPTH + CLEARANCE).

● Circle pocket (G231)

This is a menu for pocketing the circle shape.
Create ISO code program in the following form.

G231 P__ Z__ B__ J__ H__ F__ C__ W__ X__ Y__ ●●●●● ;

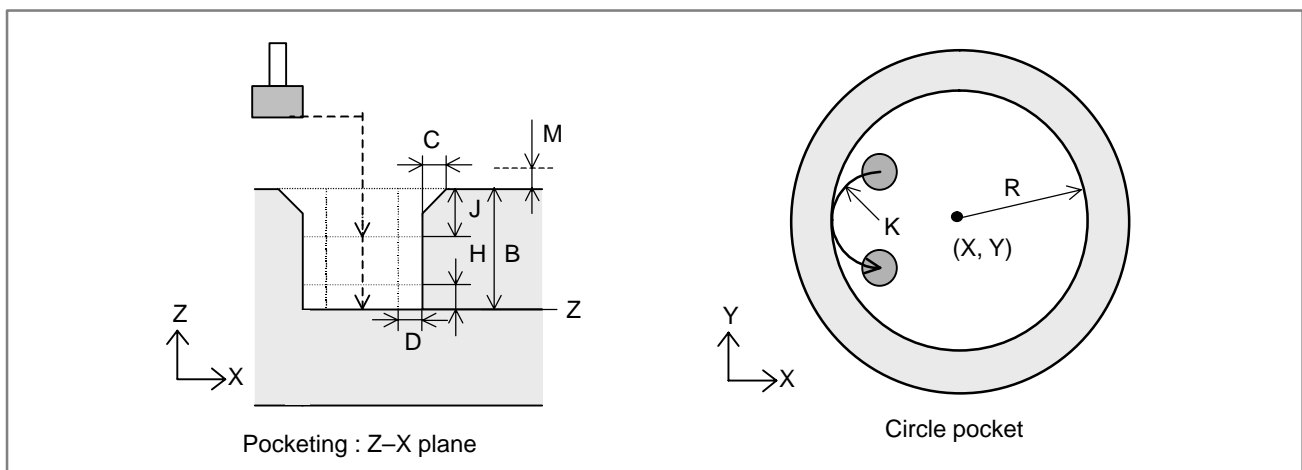

- T: Machining process
 1: Roughing
 2: Bottom finishing
 3: Side finishing
 4: Chamfering
 5: Drilling
- Z: End point Z
 Z coordinate of the final machined surface
- B: Removal depth
 The depth of the pocket.
- J: Removal pitch
 The machining allowance of one pass for rough cutting in the Z direction.
 Rough cutting is done in one pass if not input.
- H: Bottom finish
 The bottom machining allowance for bottom finish cutting. This is cut in one pass.
 Bottom finish cutting is not done if not input.
- D: Side finish
 The side machining allowance for side finish cutting.
 Side finish cutting is not done if not input.
- C: Chamfer removal
 The amount of the chamfering.
- D: Tool small diameter
 The small diameter of chamfer tool.
- J: Chamfer angle
 The tool nose angle of a chamfering tool.
- H: Tool out depth
 The thrust depth of a chamfering tool.
- F: The feed rate of the tool.
- E: Z_cut feed rate
 The cutting feed rate in Zaxis direction from point R.
 (Point R = End point Z + Bottom removal + Clearance)
- C: Cutting width
 The machining allowance of one pass in the XY direction.
 It is specified a rate (%) of the tool. (less than 70%)
- X: Center point X
 X coordinate of the center of the circle.
- Y: Center point Y
 Y coordinate of the center of the circle.
- R: Radius
 The radius of a circle.
- S: Cycle select
 Select the drilling cycle for pre-hole
 1: G81 (Normal drilling)
 2: G83 (Peck drilling)
 3: G73 (High-speed peck drilling)
- Q: Pitch depth
 The depth of cut for each cutting cycle.
 It is used for G83 (S:2) and G73 (S:3).

M: Clearance

The amount of clearance for cutting feed in the Z axis at the approach or escape movement. The default data is 3mm.

W: Cutting direction

- 1: Down-cut : Rotation of the cutting tool in the forward direction
 - 2: Up-cut : Rotation of the cutting tool in the reverse direction
- If there is no input, 1 is regarded.

K: Approach / escape

The radius of approach or escape. The movement is performed as a quarter arc.

It is calculated automatically if not input.

The following table shows addresses used in arguments in each machining process.

G231	T	Z	B	J	H	D	C	D	J	H	C	F	E	X	Y	R	S	Q	M	W	K
Rough	#	#	#	#	#	#	_	_	_	_	#	#	#	#	#	#	_	_	&	&	_
Bottom finish	#	#	#	_	#	#	_	_	_	_	#	#	#	#	#	#	_	_	&	&	_
Side finish	#	#	#	#	#	_	_	_	_	_	_	#	#	#	#	#	_	_	&	&	&
Chamfer	#	#	#	_	_	_	#	#	#	#	_	#	#	#	#	#	_	_	&	&	&
Drill	#	#	#	_	_	_	_	_	_	_	_	#	_	#	#	#	#	#	&	_	_

#: Specify necessarily

&: Specify. If there is no input, default data is specified.

_ : Do not specify.

● **Movements :**

Except for the shape of the circle, the basic machining movements are similar to those of Square pocket.

● **Track pocket (G232)**

This is a menu for pocketing the track shape.

Create ISO code program in the following form.

G232 P_ Z_ B_ J_ H_ F_ C_ W_ X_ Y_ ●●●● ;

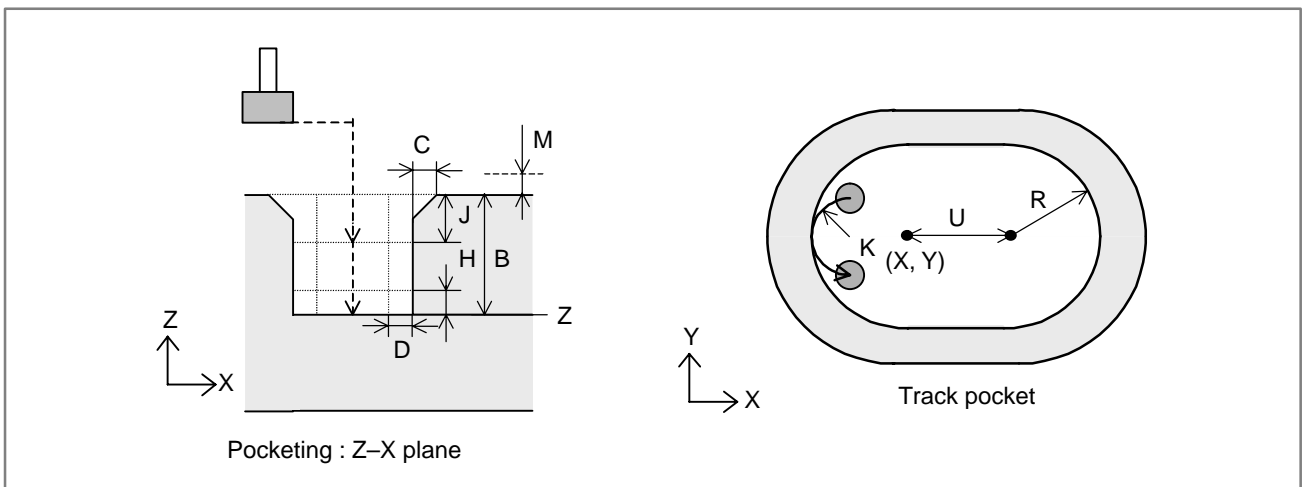

T: Machining process

- 1: Roughing
- 2: Bottom finishing
- 3: Side finishing
- 4: Chamfering
- 5: Drilling

- Z: End point Z
Z coordinate of the final machined surface
- B: Removal depth
The depth of the pocket.
- J: Removal pitch
The machining allowance of one pass for rough cutting in the Z direction.
Rough cutting is done in one pass if not input.
- H: Bottom finish
The bottom machining allowance for bottom finish cutting. This is cut in one pass.
Bottom finish cutting is not done if not input.
- D: Side finish
The side machining allowance for side finish cutting.
Side finish cutting is not done if not input.
- C: Chamfer removal
The amount of the chamfering.
- D: Tool small diameter
The small diameter of chamfer tool.
- J: Chamfer angle
The tool nose angle of a chamfering tool.
- H: Tool out depth
The thrust depth of a chamfering tool.
- F: The feed rate of the tool.
- E: Z_cut feed rate
The cutting feed rate in Zaxis direction from point R.
(Point R = End point Z + Bottom removal + Clearance)
- C: Cutting width
The machining allowance of one pass in the XY direction.
It is specified a rate (%) of the tool. (less than 70%)
- X: Center point X
X coordinate of the center of the left arc.
- Y: Center point Y
Y coordinate of the center of the left arc.
- U: Center distance
The distance between the centers of the two arcs.
- R: Radius
The radius of a circle.
- S: Cycle select
Select the drilling cycle for pre-hole
1: G81 (Normal drilling)
2: G83 (Peck drilling)
3: G73 (High-speed peck drilling)
- Q: Pitch depth
The depth of cut for each cutting cycle.
It is used for G83 (S:2) and G73 (S:3).
- M: Clearance
The amount of clearance for cutting feed in the Z axis at the approach or escape movement. The default data is 3mm.

W: Cutting direction

- 1: Down-cut : Rotation of the cutting tool in the forward direction
 - 2: Up-cut : Rotation of the cutting tool in the reverse direction
- If there is no input, 1 is regarded.

K: Approach / escape

The radius of approach or escape. The movement is performed as a quarter arc. It is calculated automatically if not input.

A: Incline angle

The angle between the U side and X axis, when the work is inclined with respect to the X axis. It is considered to be 0 if not input.

The following table shows addresses used in arguments in each machining process.

G232	T	Z	B	J	H	D	C	D	J	H	F	E	C	X	Y	U	R
Rough	#	#	#	#	#	#	_	_	_	_	#	#	#	#	#	#	#
Bottom finish	#	#	#	_	#	#	_	_	_	_	#	#	#	#	#	#	#
Side finish	#	#	#	#	#	_	_	_	_	_	#	#	_	#	#	#	#
Chamfer	#	#	#	_	_	_	#	#	#	#	#	#	_	#	#	#	#
Drill	#	#	#	_	_	_	_	_	_	_	#	_	_	#	#	#	#

G232	S	Q	M	W	K	A
Rough	_	_	&	&	_	&
Bottom finish	_	_	&	&	_	&
Side finish	_	_	&	&	&	&
Chamfer	_	_	&	&	&	&
Drill	#	#	&	_	_	&

#: Specify necessarily
 &: Specify. If there is no input, default data is specified.
 _: Do not specify.

● Groove (G233)

This is a menu for machining the linear groove.
 Create ISO code program in the following form.

G233 P_ Z_ B_ J_ H_ F_ C_ W_ X_ Y_ ●●●● ;

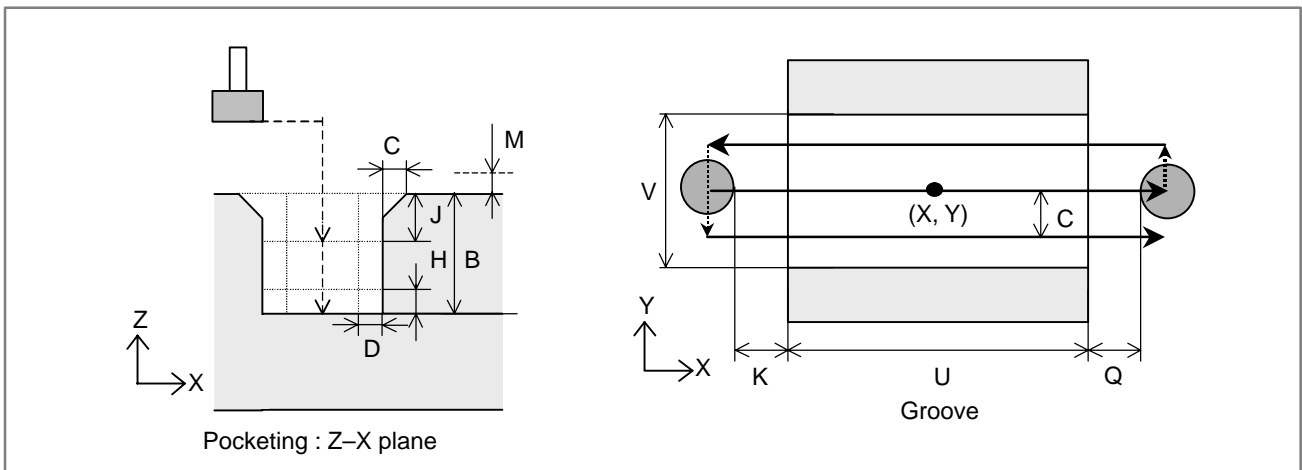

- T: Machining process
 1: Roughing
 2: Bottom finishing
 3: Side finishing
 4: Chamfering
- Z: End point Z
 Z coordinate of the final machined surface
- B: Removal depth
 The depth of the groove.
- J: Removal pitch
 The machining allowance of one pass for rough cutting in the Z direction.
 Rough cutting is done in one pass if not input.
- H: Bottom finish
 The bottom machining allowance for bottom finish cutting. This is cut in one pass.
 Bottom finish cutting is not done if not input.
- D: Side finish
 The side machining allowance for side finish cutting.
 Side finish cutting is not done if not input.
- C: Chamfer removal
 The amount of the chamfering.
- D: Tool small diameter
 The small diameter of chamfer tool.
- J: Chamfer angle
 The tool nose angle of a chamfering tool.
- H: Tool out depth
 The thrust depth of a chamfering tool.
- F: The feed rate of the tool.
- C: Cutting width
 The machining allowance of one pass in the XY direction.
 It is specified a rate (%) of the tool. (less than 70%)
- X: Center point X
 X coordinate of the center of the groove.
- Y: Center point Y
 Y coordinate of the center of the groove.
- U: U-length
 The length of the groove.
- V: Groove width
 The width of the groove.
- M: Clearance
 The amount of clearance for cutting feed in the Z axis at the approach or escape movement. The default data is 3mm.
- W: Cutting direction
 1: Down-cut : Rotation of the cutting tool in the forward direction
 2: Up-cut : Rotation of the cutting tool in the reverse direction
 If there is no input, 1 is regarded.
- A: Incline angle
 The angle between the U side and X axis, when the work is inclined with respect to the X axis. It is considered to be 0 if not input.

K: Approach gap

The gap between the tool edge in the cutting feed start point and the workpiece .

If there is no input, 5mm is regarded.

Q: Escape gap

The gap between the tool edge and the workpiece when the tool moves away from the work. If there is no input, 5mm is regarded.

N: Start point

The starting position of the machining (1, 2).

If there is no input, 1 is regarded.

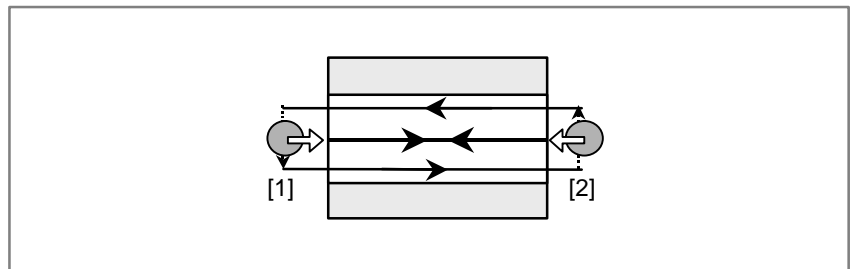

The following table shows addresses used in arguments in each machining process.

G233	T	Z	B	J	H	D	C	D	J	H	F	C	X	Y	U	V
Rough	#	#	#	#	#	#	_	_	_	_	#	#	#	#	#	#
Bottom finish	#	#	#	_	#	#	_	_	_	_	#	#	#	#	#	#
Side finish	#	#	#	#	#	_	_	_	_	_	#	_	#	#	#	#
Chamfer	#	#	#	_	_	_	#	#	#	#	#	_	#	#	#	#

G233	M	W	A	K	Q	N
Rough	&	&	&	&	&	&
Bottom finish	&	&	&	&	&	&
Side finish	&	&	&	&	&	&
Chamfer	&	&	&	&	&	&

#: Specify necessarily

&: Specify. If there is no input, default data is specified.

_ : Do not specify.

- Movements :

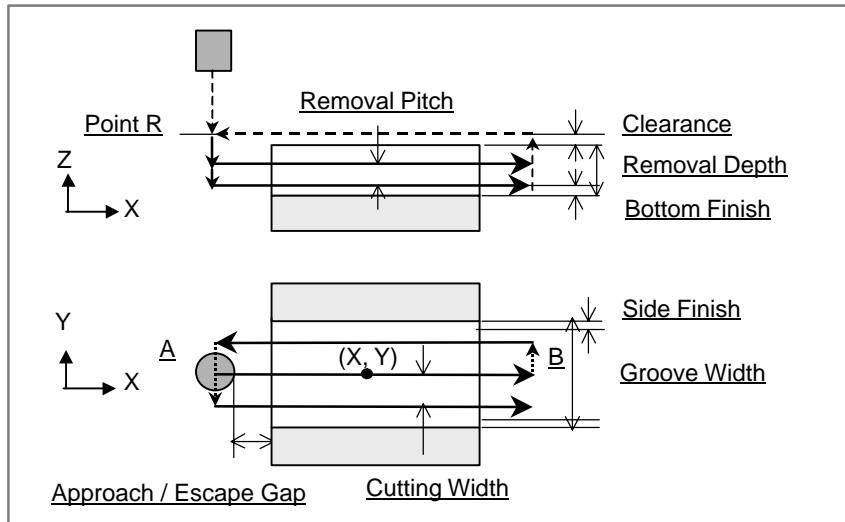
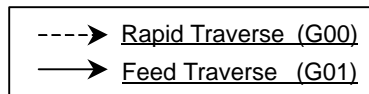

a) In the case of rough cutting

1. Rapid traverse up to the starting point (A).
2. Rapid traverse along the Z axis up to point R (END POINT Z + REMOVAL DEPTH + CLEARANCE)
3. Descent along the lower Z axis in cutting feed (Z-CUT FEED RATE) by the pitch (REMOVAL PITCH).
4. Cutting the opposite side of the starting point in cutting feed (FEED RATE).
5. Widening of the groove on the right and left sides symmetrically using the cutting width (CUTTING WIDTH).
6. The side finish allowance (SIDE FINISH) is left and the groove is cut.
7. Move up along Z axis to point R
8. 3.-7. are repeated until reaching the point of the distance (BOTTOM FINISH).
9. Rapid traverse along Z axis up to point R.

b) In the case of bottom finish cutting

1. Rapid traverse up to the starting point (A).
2. Rapid traverse along the Z axis up to point R (END POINT Z + REMOVAL DEPTH + CLEARANCE)
3. Descent along the lower Z axis in cutting feed (Z-CUT FEED RATE) up to the end point (END POINT Z).
4. Cutting the opposite side of the starting point in cutting feed (FEED RATE).
5. Widening of the groove on the right and left sides symmetrically using the cutting width (CUTTING WIDTH).
6. The groove bottom side is cut leaving the side finish allowance (SIDE FINISH).
7. Rapid traverse along Z axis up to point R

- c) In the case of side finish cutting
1. Rapid traverse up to the starting point (B).
 2. Rapid traverse along the Z axis up to point R (END POINT Z + REMOVAL DEPTH + CLEARANCE)
 3. Move down along Z axis in cutting feed (Z-CUT FEED RATE) by the pitch (REMOVAL PITCH).
 4. Both sides groove are cut by the allowance (SIDE FINISH).
 5. Move away from the workpiece after cutting.
 6. 3.-5. are repeated up to the point (END POINT Z) by the pitch (REMOVAL PITCH).
 7. Rapid traverse along Z axis up to point R (END POINT Z + REMOVAL DEPTH + CLEARANCE).
- d) In the case of chamfering
1. Rapid traverse up to the starting point (B).
 2. Rapid traverse along the Z axis up to the cutting point + CLEARANCE.
(Cutting point : It is calculated by END POINT Z, REMOVAL DEPTH, CHAMFER REMOVAL, TOOL SMALL DIA., CHAMFER ANGLE, TOOL OUT DEPTH)
 3. Move down along Z axis to the cutting point in cutting feed (Z-CUT FEED RATE).
 4. Cut into the workpiece following a circular path.
 5. Cutting of the chamfering allowance (CHAMFER REMOVAL).
 6. Move away from the workpiece following a circular path after cutting.
 7. Rapid traverse along Z axis up to point R (END POINT Z + REMOVAL DEPTH + CLEARANCE).

Note

NOTE

1 This function requires the following optional functions.

- Embedded Macro
- Canned cycle
- Custom macro B

This function consists of 83 programs. So consider the number of programs which an operator requires and specify one of the following optional functions.

- Number of Registered programs 125
- Number of Registered programs 200
- Number of Registered programs 400
- Number of Registered programs 1000

2 This function uses G codes, G200 to G233, to call macros. Of alarm Nos. 3000 to 3999, which can be generated by custom macros, alarm Nos. 3001 to 3022 are used. (See explanations about system variable #3000.) When using this function, avoid using these G codes and alarm numbers together with other custom macros.

3 The tape format for FS15 can not be used.

4 Specify D code before using G code program corresponding to Facing, Side cutting or Pocketing after tool change.

5 In principle, specify arguments in order of description in this subsection. Specially concerning addresses I, J and K, specify in the following order. Firstly I, secondly J and last K.

6 Plane selection (G17, G18 or G19) can not be specified. This feature can be used only on X-Y plane.

7 It is necessary to specify decimal points to macro call arguments.

8 This function and MANUAL GUIDE can not be specified simultaneously. MANUAL GUIDE has same functions as this function.

Alarm and message

Number	Message	Contents
3001	INPUT VALUE IS ERRONEOUS.	Necessary data is not entered. Or entered data is invalid.
3002	OFFSET VALUE IS UNDER 0.	The offset data corresponding to the specified D code is 0 or less.
3003	INTERFREE WITHWORK[RING]	The tool interferes with the opposite surface.

Number	Message	Contents
3004	TOOL IS TOO BIG.	Machining is impossible because the cutter diameter is too large.
3005	APPROACH AMOUNT ISBIG.	The tool interferes with the opposite edge because the length of approach is too long.
3006	CORNER RADIUS[R] IS BIG.	Corner R interferes with the opposite one because the radius of corner R is too large.
3007	CHAMFER AMOUNT [R] ISBIG.	Corner C interferes with the opposite one because the chamfer amount is too large.
3008	DIA. IS BIGGER THAN R.	Corner R machining can not be performed because the cutter diameter is larger than corner R
3012	CHAMF. TOOL EXCEEDS Z POINT	The chamfering tool interferes with the bottom surface (Z point) in chamfering.
3013	CHAMF. TOOL ANGLE ISLACK.	The angle at which the chamfering tool is placed is not specified.
3022	D-CODE IS NOT CORRECT.	D code is not specified.

11.6.6 Embedded Measurement Macros (M Series)

General

This subsection describes how to create programs, using embedded measurement macros. Two different canned cycles (calibration and measurement) can be used in embedded measurement macros.

G codes, such as G170 to G173 and G180 to G192, are used to call macros. Of alarm Nos. 3000 to 3999, which can be generated by custom macros, alarm Nos. 3101 to 3149 are used. When using this function, avoid using any custom macro G code or alarm number used with other custom macros.

Probe

Using embedded measurement macros requires a measurement touch sensor (probe).

The probe must be able to detect contact with a workpiece coming in any direction. It must also be able to send, to the CNC, a skip signal to indicate when the probe detects contact.

Be sure to connect the probe in such a way that the skip signal can be input to the CNC when the probe detects contact with the workpiece, by referencing the applicable operator's manual publicized by the manufacturer of the probe and Section 14.3, "Skip Function," of this manual.

Measurement macro variables

Data used in common to every measurement cycle must previously be set in macro variables (common variables).

1. Calibration macro variables

The following macro variables are used to calibrate the probe. Executing a calibration cycle sets up these variables automatically. If you do not execute a calibration cycle or do execute a calibration cycle using empirical compensation data, set up the following macro variables in advance.

- #200: Probe length → automatically set up with G170.
The probe length is the distance from the gage face on the tapered section of the spindle to the tip of the stylus.
- #201: Stylus ball diameter in the X-axis direction → automatically set up with G171.
- #202: Stylus ball diameter in the Y-axis direction → automatically set up with G171.
- #203: Stylus ball compensation amount in the X-axis direction → automatically set up with G172 and G173.
- #204: Stylus ball compensation amount in the Y-axis direction → automatically set up with G172 and G173.
This value is a compensation amount for any displacement of the stylus center from the spindle center.

NOTE

An alarm is issued if the setting of any of the above macro variables is null or 0.

2. Measurement cycle macro variables

The following macro variables specify data to be used in measurement. Be sure to set up these macro variables before using measurement cycles.

- #210: Measurement speed (f) used in the first measurement session
- #211: Approach distance (α) used in the first measurement session
This macro variable specifies how close the probe is to get to the measurement face (measured in mm).
- #212: Return distance (β) in the first measurement session
This macro variable specifies the distance (measured in mm) through which the probe is to return after it touches the measurement face in the first measurement session. (This value is used as an approach value in the second session of measurement.)
- #213: Excess distance (γ) in measurement
This macro variable specifies the distance (measured in mm) through which the probe advances beyond the measurement face.
- #214: Movement speed (fa) for the probe to get to the measurement start point
This macro variable specifies the speed at which the probe moves to get to the measurement start point. (An alarm is issued if the probe collides with an object like the workpiece when it is moving toward the measurement start point.)

- #215: Return distance (ϵ) after the second contact
 This macro variable specifies the distance (measured in mm) through which the probe is to return after it touches the measurement face the second time.

NOTE
 An alarm is issued if the setting of any of the above macro variables is 0.

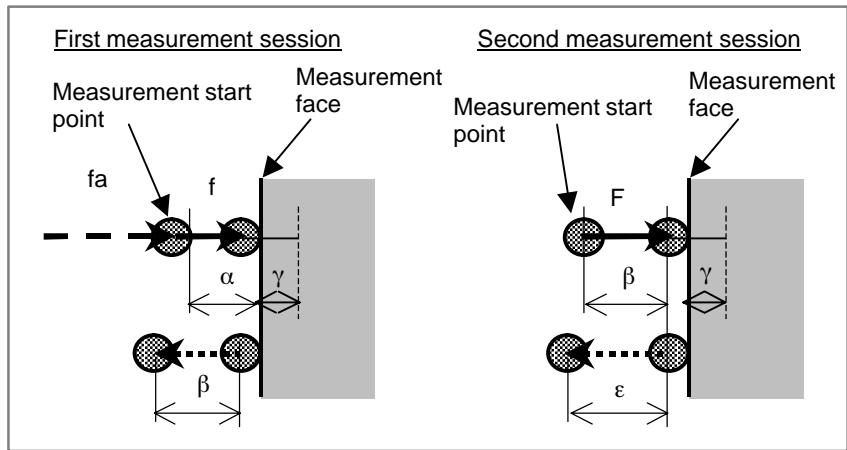

Calibration cycle

This cycle uses a ring gage to measure probe compensation data and sets measurement results in macro variables. The measurement cycle references these macro variables for measurement. The calibration cycle always involves two measurement sessions. The first measurement session verifies the position of measurement, and the second measurement session makes an accurate measurement at the verified measurement position.

NOTE
 Before executing this cycle, place a ring gage on the table, and move the probe near to (right above) the ring gage.

• **Probe length measurement (G170)**

The distance from the gage face on the tapered section of the spindle to the stylus tip is measured by generating a G code program in the following format:

```
G170Z_D_H_F_;
```

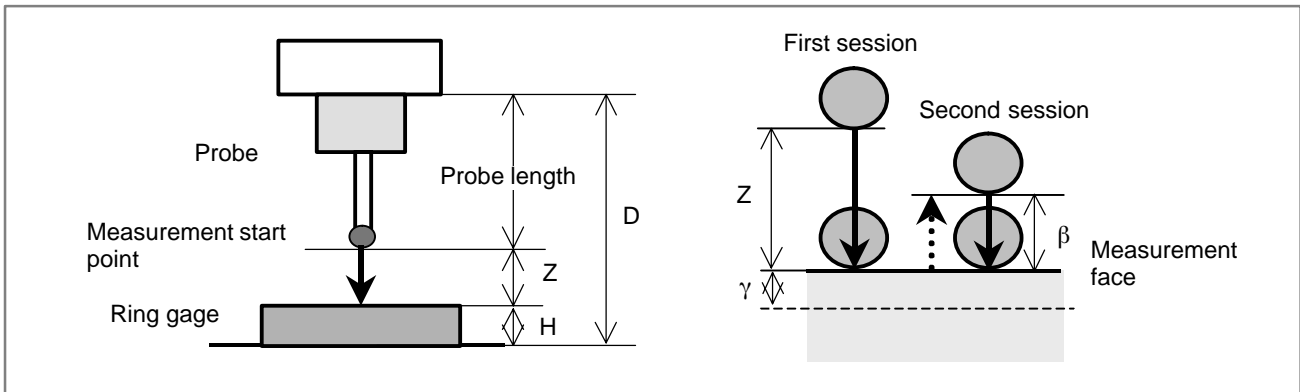

Z: Movement distance

Specifies the distance from the measurement start point to the ring gage.

D: Gage line-to-table distance

Specifies the distance from the gage line to the table.

H: Ring gage height

Specifies the height of the ring gage.

F: Movement speed

Specifies the speed at which the probe is to move for measurement.

Measurement sequence:

What is done during measurement is described below.

- 1) The probe moves at the speed f in the range " $Z + \gamma$ " from the measurement start point until it touches the table (the first measurement session).
- 2) The probe returns through the distance β at the rapid traverse rate.
- 3) The probe moves at the specified speed F in the range " $\beta + \gamma$ " until it touches the table (the second measurement session).

Executing G170 obtains the length of the probe from a measured value and outputs the obtained probe length in the following macro variable:

#200: Probe length

- **Stylus ball diameter measurement (G171)**

The stylus ball diameters in both X-axis and Y-axis directions are measured by creating a G code program in the following format:

G171Z__R__F__ ;

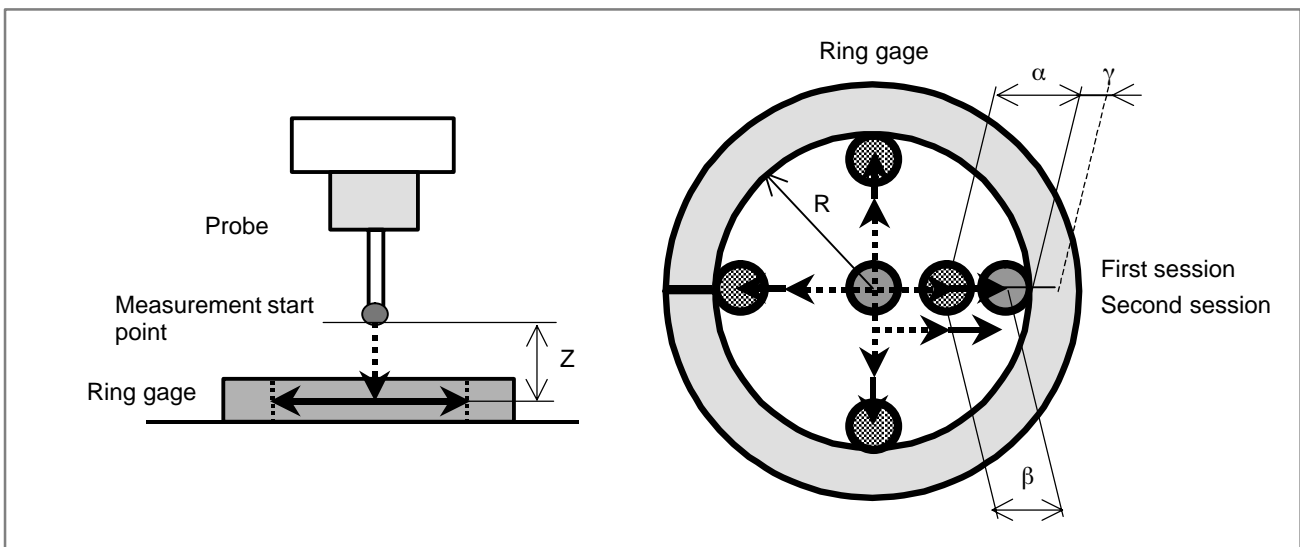

Z: Movement distance

Specifies the distance from the measurement start point to the ring gage.

R: Ring gage radius

Specifies the height of the ring gage.

F: Movement speed

Specifies the speed at which the probe is to move for measurement.

Measurement sequence:

What is done during measurement is described below.

- 1) The probe moves at the speed f_a through the distance Z in the negative Z-axis direction.

- 2) The probe moves at the speed f_a through the distance " $R - \alpha$ " in the positive X-axis direction.
- 3) The probe moves at the speed f_a in the range " $R + \gamma$ " until it touches the ring gage.
- 4) The probe moves at the rapid traverse rate to the center X-axis coordinate where it was before the start of measurement, and makes the same measurement as stated above in the negative X-axis direction and the Y-axis direction (the first measurement session).
- 5) The probe moves at the speed f_a in the positive X-axis to a point the distance "first measurement session measurement position - β " away from the measurement start point.
- 6) The probe moves at the speed F in the range " $\beta + \gamma$ " until it touches the ring gage.
- 7) The probe makes the same measurement as stated above in the negative X-axis direction and the Y-axis direction (the second measurement session).

Executing G171 obtains the stylus ball diameters in the X-axis and Y-axis directions from measured values, and outputs the obtained diameters in the following macro variables:

- #201: Stylus ball diameter in the X-axis direction
- #202: Stylus ball diameter in the Y-axis direction

● **Stylus ball center displacement measurement A (G172)**

The displacement of the stylus center from the spindle center is measured. Use this cycle for machines that use the spindle orientation function (see Chapter 6, "Parameters"). Create a G code program in the following format:

```
G172Z_R_F_;
```

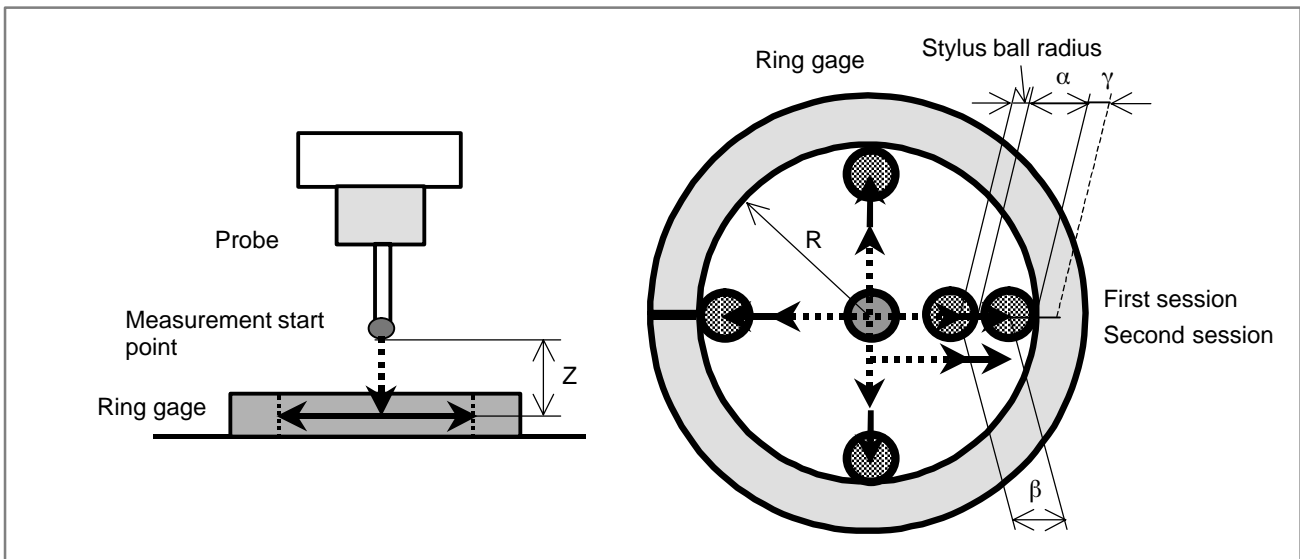

- Z: Movement distance
Specifies the distance from the measurement start point to the ring gage.
- R: Ring gage radius
Specifies the height of the ring gage.
- F: Movement speed
Specifies the speed at which the probe is to move for measurement.

Measurement sequence:

What is done during measurement is described below.

- 1) The probe moves at the speed f_a in the negative Z-axis direction to a point the distance Z away from the measurement start point.
- 2) The probe moves at the speed f_a in the positive X-axis direction to a point the distance " $R - \alpha - \text{stylus ball radius}$ " away from the measurement start point.
- 3) The probe moves at the speed f in the range " $R + \gamma - \text{stylus ball radius}$ " until it touches the ring gage.
- 4) The probe moves at the rapid traverse rate to the center X-axis coordinate where it was before the start of measurement, and makes the same measurement as stated above in the negative X-axis direction and the Y-axis direction (the first measurement session).
- 5) The probe moves at the speed f_a in the positive X-axis to a point the distance " $\text{first-measurement session measurement position} - \beta$ " away from the measurement start point.
- 6) The probe moves at the speed F in the range " $\beta + \gamma$ " until it touches the ring gage.
- 7) The probe makes the same measurement as stated above in the negative X-axis direction and the Y-axis direction (the second measurement session).
- 8) Orient the spindle to 180° , and make the same measurement as stated above in both X-axis and Y-axis directions again.

Executing G172 obtains stylus ball displacement values in the X-axis and Y-axis directions from measured values, and outputs the obtained values in the following macro variables:

#203: Stylus ball compensation amount in the X-axis direction

#204: Stylus ball compensation amount in the Y-axis direction

- **Stylus ball center displacement measurement B (G173)**

The displacement of the stylus center from the spindle center is measured. Use this cycle for machines that use the spindle orientation function. Create a G code program in the following format:

```
G173X__Y__Z__R__F__ ;
```

X: Center X coordinate

Specifies the X coordinate of the ring gage center.

Y: Center Y coordinate

Specifies the Y coordinate of the ring gage center.

Z: Movement distance

Specifies the distance from the measurement start point to the ring gage.

R: Ring gage radius

Specifies the height of the ring gage.

F: Movement speed

Specifies the speed at which the probe is to move for measurement.

Measurement sequence:

What is done during measurement is described below.

- 1) The probe moves at the speed f_a in the negative Z-axis direction to a point the distance Z away from the measurement start point.
- 2) The probe moves at the speed f_a in the positive X-axis direction to a point the distance " $R - \alpha - \text{stylus ball radius}$ " away from the measurement start point.

- 3) The probe moves at the speed f in the range " $R + \gamma$ - stylus ball radius" until it touches the ring gage.
- 4) The probe moves at the rapid traverse rate to the center X-axis coordinate where it was before the start of measurement, and makes the same measurement as stated above in the negative X-axis direction and the Y-axis direction (the first measurement session).
- 5) The probe moves at the speed f_a in the positive X-axis to a point the distance " $\text{first-measurement session measurement position} - \beta$ " away from the measurement start point.
- 6) The probe moves at the speed F in the range " $\beta + \gamma$ " until it touches the ring gage.
- 7) The probe makes the same measurement as stated above in the negative X-axis direction and the Y-axis direction (the second measurement session).

Executing G173 obtains stylus ball displacement values in the X-axis and Y-axis directions from measured values, and outputs the obtained values in the following macro variables:

#203: Stylus ball compensation amount in the X-axis direction

#204: Stylus ball compensation amount in the Y-axis direction

• Measurement cycle

The measurement cycle always involves two measurement sessions. The first measurement session verifies the position of measurement, and the second measurement session makes an accurate measurement at the verified measurement position. This measurement cycle measures the coordinates and dimensions of the workpiece that are to be used as references, and sets them in the workpiece zero point offset value and common variables.

NOTE

- 1 Before using this measurement cycle, execute calibration cycles.
- 2 Before issuing a command for each measurement cycle, move the probe to the measurement start point.

• X/Y/Z end face measurement (G180)

The position of an end face in the X-, Y-, or Z-axis direction is measured by creating a G code program in the following format:

```
G180A__V__D__F__W__ ;
```

A: Measurement position

- 1: X end face
- 2: Y end face
- 3: Z end face

V: Workpiece coordinate value

Specifies a workpiece coordinate value for setting the measurement position.

D: Travel distance

Specifies the distance from the measurement start point to the end face to be measured. For measurement along either the X- or Y-axis, the positive and negative directions can be specified, using the algebraic signs + and -, respectively. For measurement along the Z-axis, only the negative direction can be specified; the positive direction cannot be specified.

F: Movement speed

Specify the speed at which the probe is to move for measurement.

W: Workpiece coordinate system

Select a workpiece coordinate system to be set up, and enter the corresponding number listed below:

G54 to G59: 1 = G54, 2 = G55, 3 = G56, 4 = G57, 5 = G58, and 6 = G59

If 48 coordinate systems are valid, select a workpiece coordinate system to be set up, and enter the corresponding number listed below

G54.1P1 to P48: 1001 = G54P1, 1002 = G54P2, ..., 1048 = G54P48

Measurement sequence:

- X/Y end face

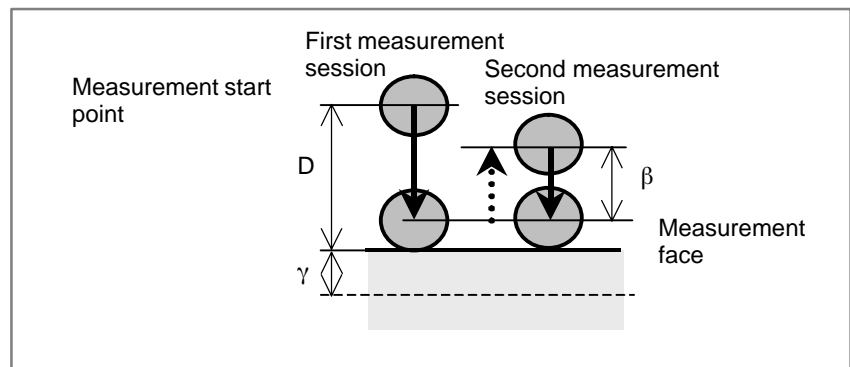

- 1) The probe moves at the speed f from the measurement start point in the range " $D + \gamma$ - stylus ball radius" until it touches the measurement face (the first measurement session).
- 2) The probe returns through the distance β at the rapid traverse rate.
- 3) The probe moves at the specified speed F in the range " $\beta + \gamma$ " until it touches the measurement face (the second measurement session).

- Z end face

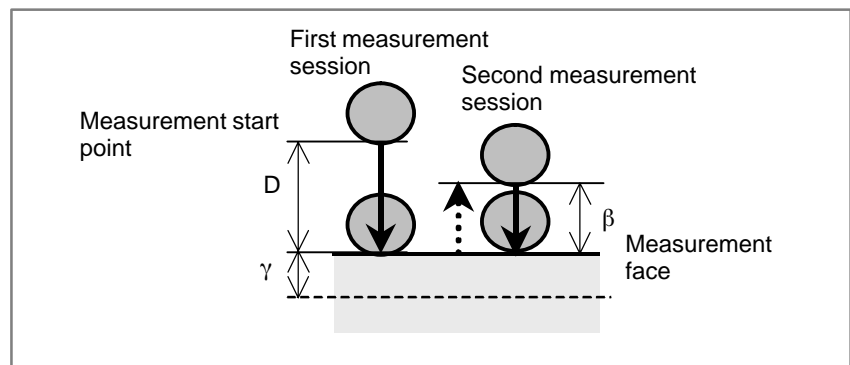

- 1) The probe moves at the speed f from the measurement start point in the range " $D + \gamma$ " until it touches the measurement face (the first measurement session).
- 2) The probe returns the distance β at the rapid traverse rate.
- 3) The probe moves at the specified speed F in the range " $\beta + \gamma$ " until it touches the measurement face (the second measurement session).

Executing G180 obtains a reference point from the input and measured values, and outputs the obtained values to the W-specified workpiece zero point offset value and the following macro variables.

#250: End face measurement value (machine coordinate system)

#251: End face measurement value (workpiece coordinate system)

● **Measuring the width of a projection (G181)**

The center position across the width of a projection and the width of the projection are measured by creating a G code program in the following format:

G180Z__D__V__F__W__ ;

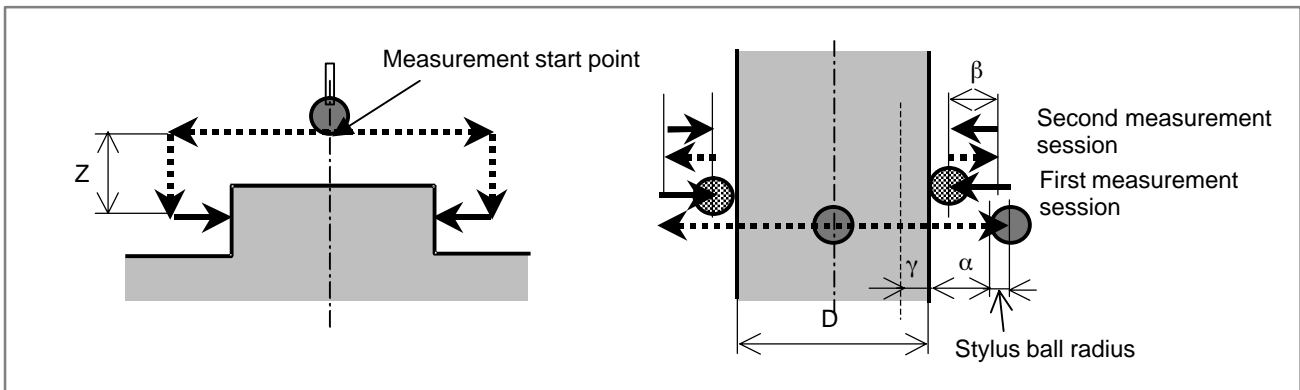

Z: Height along the Z-axis

Specifies the distance from the measurement start point to the measurement point along the Z-axis.

D: Measurement direction

1: X-axis direction

2: Y-axis direction

V: Projection width

Specifies the nominal width of a projection to be measured.

F: Movement speed

Specifies the speed at which the probe is to move for measurement.

W: Workpiece coordinate system

Select a workpiece coordinate system to be set up, and enter the corresponding number listed below:

G54 to G59: 1 = G54, 2 = G55, 3 = G56, 4 = G57, 5 = G58, and 6 = G59

If 48 coordinate systems are valid, the following numbers are specified to select desired workpiece coordinate systems:

G54.1P1 to P48: 1001 = G54P1, 1002 = G54P2, ..., 1048 = G54P48

NOTE

Before issuing a command for this cycle, be sure to set the probe above the approximate center of the width of the projection.

Measurement sequence:

- 1) The probe moves at the speed f_a in the X-axis (Y-axis) direction to a point the distance " $V/2 + \alpha + \text{stylus ball radius}$ " away from the measurement start point.

- 2) The probe moves at the speed f_a in the negative Z -axis direction to a point the distance Z away from the measurement start point.
- 3) The probe moves at the speed f in the range " $V/2 - \gamma + \text{stylus ball radius}$ " until it touches the measurement face (the first measurement session).
- 4) The probe returns through the distance β at the rapid traverse rate.
- 5) The probe moves at the specified speed F in the range " $\beta + \gamma$ " until it touches the measurement face (the second measurement session).
- 6) The probe makes the same measurement as stated above in the negative X -axis direction and the negative Y -axis direction.

Executing G181 obtains the center point of the width of the projection and the width of the projection from measured values, and outputs the obtained values to the W -specified workpiece zero point offset value and the following macro variables:

- #250: Center coordinate of the projection in the X -axis direction (machine coordinate system)
- #251: Center coordinate of the projection in the Y -axis direction (machine coordinate system)
- #252: Center coordinate of the projection in the X -axis direction (workpiece coordinate system)
- #253: Center coordinate of the projection in the Y -axis direction (workpiece coordinate system)
- #254: Width of the projection

• Measuring the width of a groove (G182)

The center position and dimension of the width of a groove are measured by creating a G code program in the following format:

G182Z__D__V__F__W__ ;

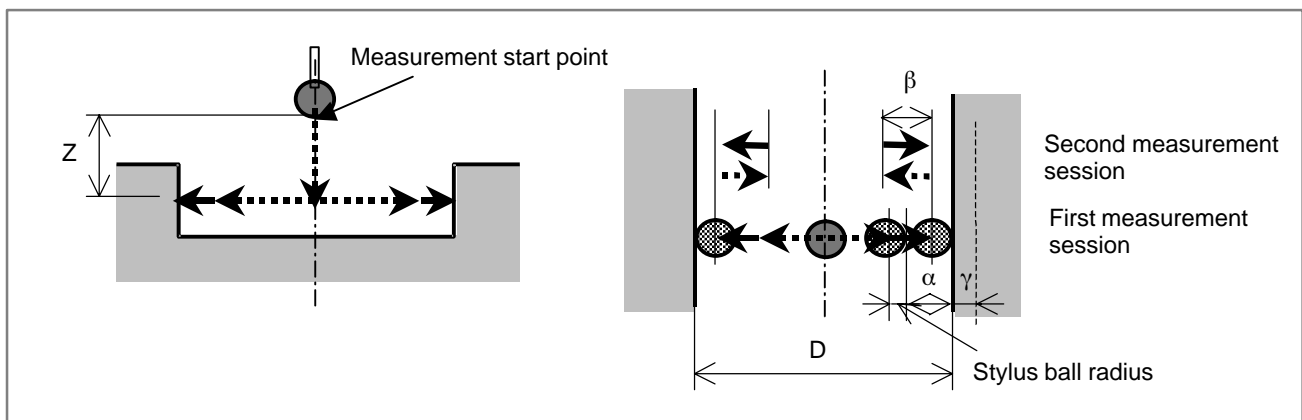

Z: Height along the Z -axis

Specifies the distance from the measurement start point to the measurement point along the Z -axis.

D: Measurement direction

- 1: X -axis direction
- 2: Y -axis direction

V: Groove width

Specifies the nominal width of a groove to be measured.

F: Movement speed

Specifies the speed at which the probe is to move for measurement.

W: Workpiece coordinate system

Select a workpiece coordinate system to be set up, and enter the corresponding number listed below:

G54 to G59: 1 = G54, 2 = G55, 3 = G56, 4 = G57, 5 = G58, and 6 = G59

If 48 coordinate systems are valid, the following numbers are specified to select desired workpiece coordinate systems:

G54.1P1 to P48: 1001 = G54P1, 1002 = G54P2, ..., 1048 = G54P48

NOTE

Before issuing a command for this cycle, be sure to set the probe above the approximate center of the width of the groove.

Measurement sequence:

- 1) The probe moves at the speed f_a in the negative Z-axis direction to a point the distance Z away from the measurement start point.
- 2) The probe moves at the speed f_a in the X-axis (Y-axis) direction to a point the distance " $V/2 - \alpha - \text{stylus ball radius}$ " away from the measurement start point.
- 3) The probe moves at the speed f in the range " $V/2 + \gamma - \text{stylus ball radius}$ " until it touches the measurement face (the first measurement session).
- 4) The probe returns through the distance β at the rapid traverse rate.
- 5) The probe moves at the specified speed F in the range " $\beta + \gamma$ " until it touches the measurement face (the second measurement session).
- 6) Make the same measurement as stated above in the negative X-axis direction (negative Y-axis) direction.

Executing G182 obtains the center point and dimension of the width of the groove from measured values, and outputs the obtained values to the W-specified workpiece zero point offset value and the following macro variables:

#250: Center coordinate of the groove in the X-axis direction (machine coordinate system)

#251: Center coordinate of the groove in the Y-axis direction (machine coordinate system)

#252: Center coordinate of the groove in the X-axis direction (workpiece coordinate system)

#253: Center coordinate of the groove in the Y-axis direction (workpiece coordinate system)

#254: Width of the groove

• **Measuring a cylinder outside radius (G183)**

The center position and outside radius of a cylinder are measured by creating a G code program in the following format:

G183Z__R__F__W__ ;

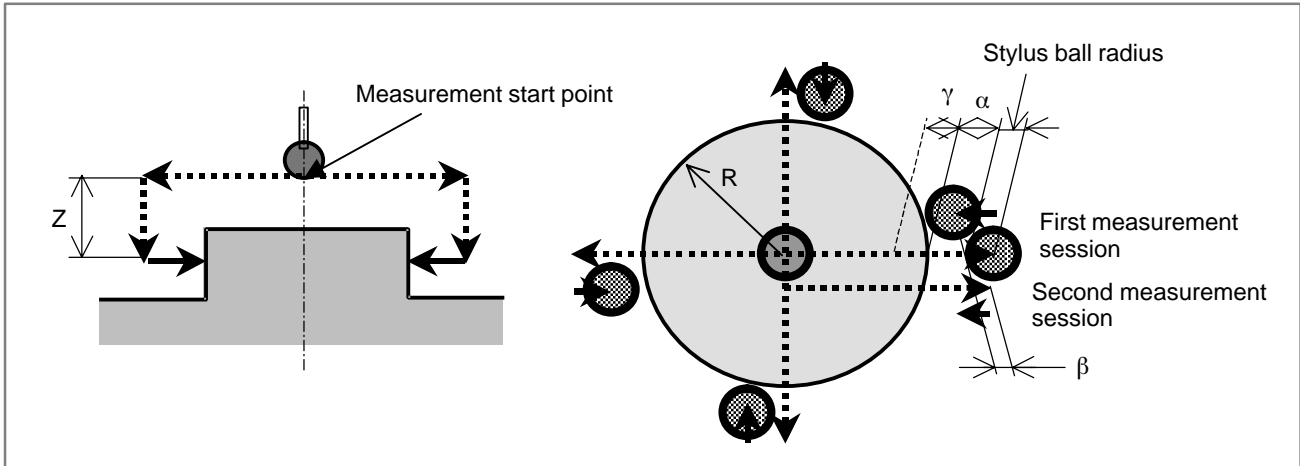

Z: Height along the Z-axis

Specifies the distance from the measurement start point to the measurement point along the Z-axis.

R: Outside radius

Specifies the nominal outside radius of a cylinder.

F: Movement speed

Specifies the speed at which the probe is to move for measurement.

W: Workpiece coordinate system

Select a workpiece coordinate system to be set up, and enter the corresponding number listed below:

G54 to G59: 1 = G54, 2 = G55, 3 = G56, 4 = G57, 5 = G58, and 6 = G59

If 48 coordinate systems are valid, the following numbers are specified to select desired workpiece coordinate systems:

G54.1P1 to P48: 1001 = G54P1, 1002 = G54P2, ..., 1048 = G54P48

NOTE

Before issuing a command for this cycle, be sure to set the probe above the approximate center of the outside-surface cylinder.

Measurement sequence:

- 1) The probe moves at the speed f_a in the positive X-axis direction to a point the distance " $R + \alpha + \text{stylus ball radius}$ " away from the measurement start point.
- 2) The probe moves at the speed f_a in the negative Z-axis direction to a point the distance Z away from the measurement start point.
- 3) The probe moves at the speed f in the range " $R - \gamma + \text{stylus ball radius}$ " until it touches the measurement face.
- 4) The probe returns through the distance ε at the rapid traverse rate.
- 5) The probe moves at the rapid traverse rate to the point where it was before the start of measurement along the Z-axis.

- 6) The probe moves at the rapid traverse rate to the center X coordinate where it was before the start of measurement, and makes the same measurement as stated above in the negative X-axis direction and the Y-axis direction (the first measurement session).
- 7) The probe moves at the speed f_a in the positive X-axis direction to a point the distance "first-measurement session measurement position - β " away from the measurement start point.
- 8) The probe moves at the specified speed F in the range " $\beta + \gamma$ " until it touches the measurement face.
- 9) The probe returns through the distance ϵ at the rapid traverse rate.
- 10) The probe moves at the rapid traverse rate to the point where it was before the start of measurement along the Z-axis.
- 11) The probe moves at the rapid traverse rate to the center X coordinate where it was before the start of measurement, and makes the same measurement as stated above in the negative X-axis direction and the Y-axis direction (the second measurement session).

Executing G183 obtains the center and radius of the cylinder from measured values, and outputs the obtained values to the W-specified workpiece zero point offset value and the following macro variables:

- #250: Center X coordinate of the cylinder circle (machine coordinate system)
- #251: Center Y coordinate of the cylinder circle (machine coordinate system)
- #252: Center X coordinate of the cylinder circle (workpiece coordinate system)
- #253: Center Y coordinate of the cylinder circle (workpiece coordinate system)
- #254: Cylinder radius

- **Measuring a cylinder inside radius (G184)**

The center position and inside radius of a cylinder are measured by creating a G code program in the following format:

G184Z__R__F__W__ ;

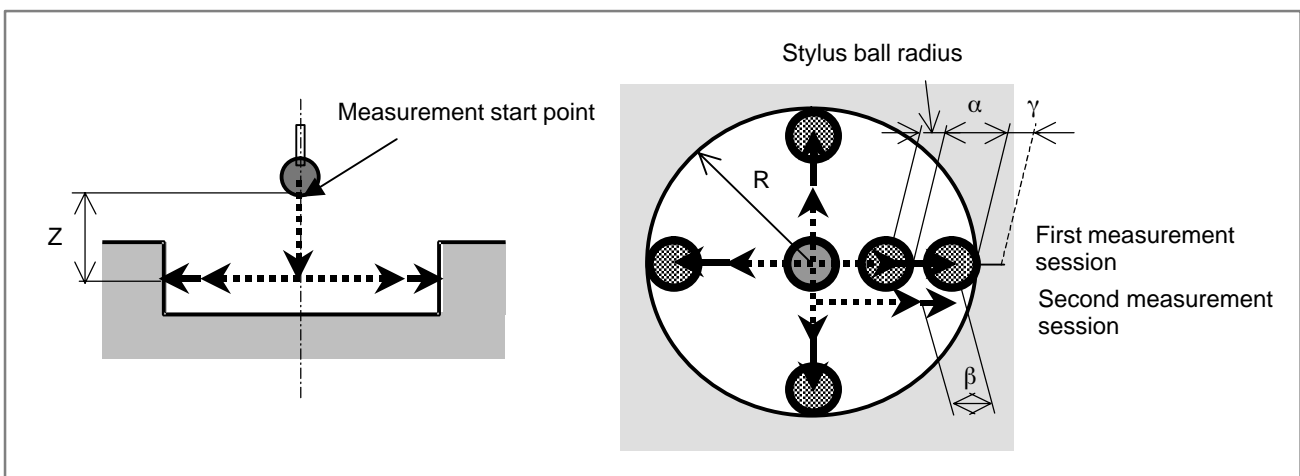

Z: Height along the Z-axis

Specifies the distance from the measurement start point to the measurement point along the Z-axis.

R: Inside radius

Specifies the nominal inside radius of a cylinder.

F: Movement speed

Specifies the speed at which the probe is to move for measurement.

W: Workpiece coordinate system

Select a workpiece coordinate system to be set up, and enter the corresponding number listed below:

G54 to G59: 1 = G54, 2 = G55, 3 = G56, 4 = G57, 5 = G58, and 6 = G59

If 48 coordinate systems are valid, the following numbers are specified to select desired workpiece coordinate systems:

G54.1P1 to P48: 1001 = G54P1, 1002 = G54P2, ..., 1048 = G54P48

NOTE

Before issuing a command for this cycle, be sure to set the probe above the approximate center of the inside-surface cylinder.

Measurement sequence:

- 1) The probe moves at the speed f_a in the negative Z-axis direction to a point the distance Z away from the measurement start point.
- 2) The probe moves at the speed f_a in the positive X-axis direction to a point the distance " $R - \alpha - \text{stylus ball radius}$ " away from the measurement start point.
- 3) The probe moves at the speed f in the range " $R + \gamma - \text{stylus ball radius}$ " until it touches the measurement face.
- 4) The probe moves to the center X coordinate where it was before the start of measurement, and makes the same measurement as stated above in the negative X-axis direction and the Y-axis direction (the first measurement session).
- 5) The probe moves at the speed f_a in the positive X-axis direction to a point the distance " $\text{first-measurement session measurement position} - \beta$ " away from the measurement start point.
- 6) The probe moves at the specified speed F in the range " $\beta + \gamma$ " until it touches the measurement face.
- 7) The probe makes the same measurement as stated above in the negative X-axis direction and the Y-axis direction (the second measurement session).

Executing G184 obtains the center and radius of the cylinder from measured values, and outputs the obtained values to the W-specified workpiece zero point offset value and the following macro variables:

#250: Center X coordinate of the cylinder (machine coordinate system)

#251: Center Y coordinate of the cylinder (machine coordinate system)

#252: Center X coordinate of the cylinder (workpiece coordinate system)

#253: Center Y coordinate of the cylinder (workpiece coordinate system)

#254: Cylinder radius

● **Measuring the outside sides of a rectangle (G185)**

The center of a rectangle and the size of its outside sides in the X-axis and Y-axis directions are measured by creating a G code program in the following format:

G185Z__U__V__F__W__ ;

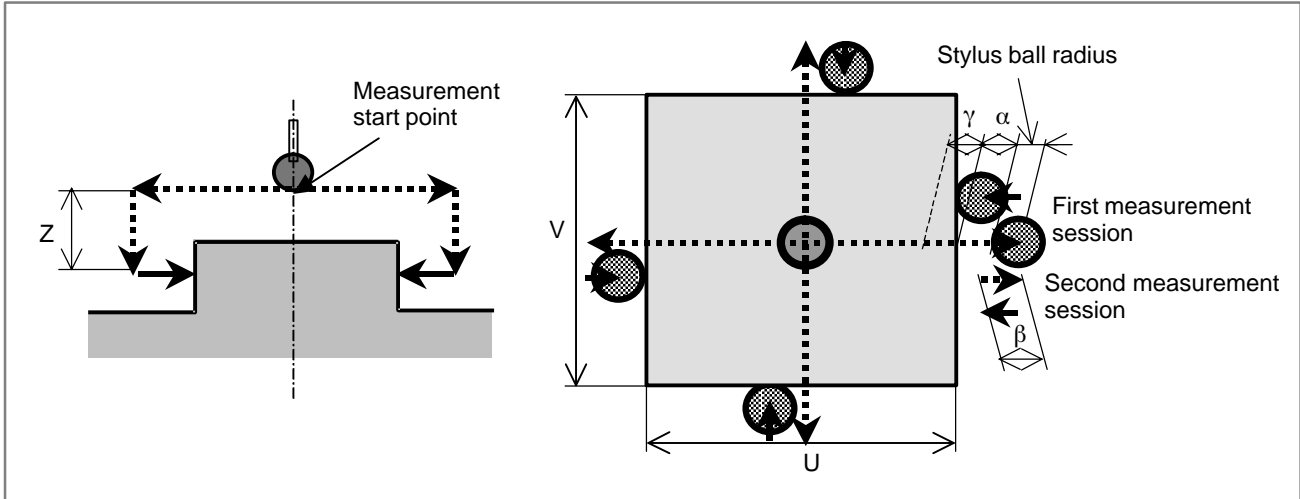

Z: Height along the Z-axis

Specifies the distance from the measurement start point to the measurement point along the Z-axis.

U: Length in the X-axis direction

Specifies the nominal length of the rectangle in the X-axis direction.

V: Length in the Y-axis direction

Specifies the nominal length of the rectangle in the Y-axis direction.

F: Movement speed

Specifies the speed at which the probe is to move for measurement.

W: Workpiece coordinate system

Select a workpiece coordinate system to be set up, and enter the corresponding number listed below:

G54 to G59: 1 = G54, 2 = G55, 3 = G56, 4 = G57, 5 = G58, and 6 = G59

If 48 coordinate systems are valid, the following numbers are specified to select desired workpiece coordinate systems:

G54.1P1 to P48: 1001 = G54P1, 1002 = G54P2, ..., 1048 = G54P48

NOTE

Before issuing a command for this cycle, be sure to set the probe above the approximate center of the rectangle.

Measurement sequence:

- 1) The probe moves at the speed f_a in the positive X-axis direction to a point the distance " $U/2 + \alpha + \text{stylus ball radius}$ " away from the measurement start point.
- 2) The probe moves at the speed f_a in the negative Z-axis direction to a point the distance Z away from the measurement start point.

- 3) The probe moves at the speed f in the range " $U/2 - \gamma + \text{stylus ball radius}$ " until it touches the measurement face (the first measurement session).
- 4) The probe returns through the distance β at the rapid traverse rate.
- 5) The probe moves at the specified speed F in the range " $\beta + \gamma$ " until it touches the measurement face (the second measurement session).
- 6) The probe returns through the distance ε at the rapid traverse rate.
- 7) The probe moves at the rapid traverse rate to the point where it was before the start of measurement along the Z -axis.
- 8) The probe moves at the rapid traverse rate to the center X coordinate where it was before the start of measurement, and makes the same measurement as stated above in the negative X -axis direction and the Y -axis direction.

Executing G185 obtains the center of a rectangle and the length of its sides from measured values, and outputs the obtained values to the W -specified workpiece zero point offset value and the following macro variables:

- #250: Center X coordinate of the rectangle (machine coordinate system)
- #251: Center Y coordinate of the rectangle (machine coordinate system)
- #252: Center X coordinate of the rectangle (workpiece coordinate system)
- #253: Center Y coordinate of the rectangle (workpiece coordinate system)
- #254: Length of the rectangle side along the X -axis
- #255: Length of the rectangle side along the Y -axis

- **Measuring the inside sides of a rectangle (G186)**

The center of a rectangle and the size of its inside sides in the X -axis and Y -axis directions are measured by creating a G code program in the following format:

G186Z__U__V__F__W__ ;

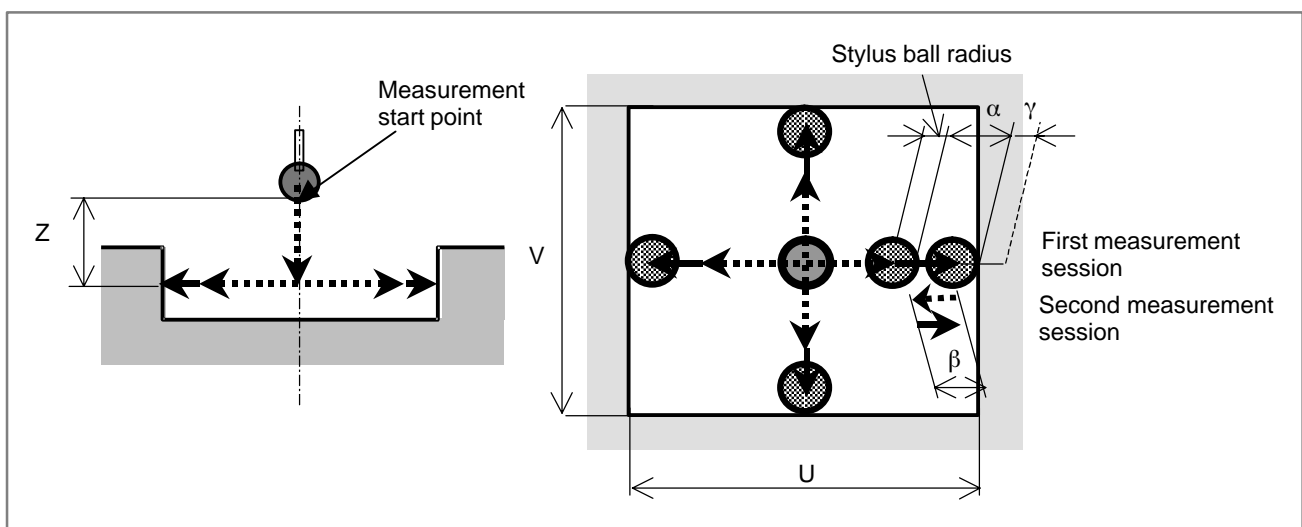

Z: Height along the Z -axis

Specifies the distance from the measurement start point to the measurement point along the Z -axis.

U: Length in the X-axis direction

Specifies the nominal length of the rectangle in the X-axis direction.

V: Length in the Y-axis direction

Specifies the nominal length of the rectangle in the Y-axis direction.

F: Movement speed

Specifies the speed at which the probe is to move for measurement.

W: Workpiece coordinate system

Select a workpiece coordinate system to be set up, and enter the corresponding number listed below:

G54 to G59: 1 = G54, 2 = G55, 3 = G56, 4 = G57, 5 = G58, and 6 = G59

If 48 coordinate systems are valid, the following numbers are specified to select desired workpiece coordinate systems:

G54.1P1 to P48: 1001 = G54P1, 1002 = G54P2, ..., 1048 = G54P48

NOTE

Before issuing a command for this cycle, be sure to set the probe above the approximate center of the rectangle.

Measurement sequence:

- 1) The probe moves at the speed f_a in the negative Z-axis direction to a point the distance Z away from the measurement start point.
- 2) The probe moves at the speed f_a in the positive X-axis direction to a point the distance " $U/2 - \alpha - \text{stylus ball radius}$ " away from the measurement start point.
- 3) The probe moves at the speed f in the range " $U/2 + \gamma - \text{stylus ball radius}$ " until it touches the measurement face (the first measurement session).
- 4) The probe returns through the distance β at the rapid traverse rate.
- 5) The probe moves at the specified speed F in the range " $\beta + \gamma$ " until it touches the measurement face (the second measurement session).
- 6) The probe moves at the rapid traverse rate to the center X coordinate where it was before the start of measurement, and makes the same measurement as stated above in the negative X-axis direction and the Y-axis direction.

Executing G186 obtains the center of a rectangle and the length of its sides from measured values, and outputs the obtained values to the W-specified workpiece zero point offset value and the following macro variables:

#250: Center X coordinate of the rectangle (machine coordinate system)

#251: Center Y coordinate of the rectangle (machine coordinate system)

#252: Center X coordinate of the rectangle (workpiece coordinate system)

#253: Center Y coordinate of the rectangle (workpiece coordinate system)

#254: Length of the rectangle side along the X-axis

#255: Length of the rectangle side along the Y-axis

- **Measuring an outside corner (G187)**

The position of an outside corner is measured by creating a G code program in the following format:

```
G187A__B__C__D__U__V__I__J__F__W__ ;
```

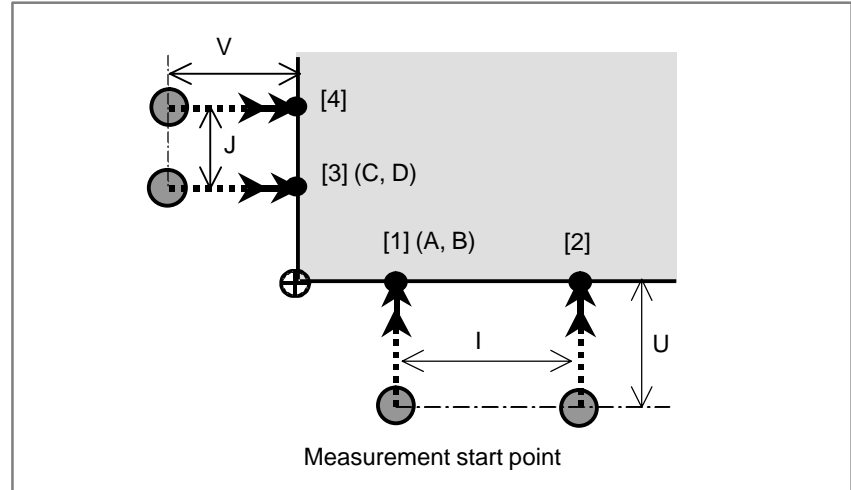

- A: X coordinate of measurement point 1
Specifies the X coordinate of measurement point 1.
- B: Y coordinate of measurement point 1
Specifies the Y coordinate of measurement point 1.
- C: X coordinate of measurement point 3
Specifies the X coordinate of measurement point 3.
- D: Y coordinate of measurement point 3
Specifies the Y coordinate of measurement point 3.
- U: Distance in the X-axis direction
Specifies the distance from the measurement start point to the measurement end face in the X-axis direction.
- V: Distance in the Y-axis direction
Specifies the distance from the measurement start point to the measurement end face in the Y-axis direction.
- I: Increment in the X-axis direction
Specifies an increment (distance from measurement point [1] to measurement point [2]) in the X-axis direction.
- J: Increment in the Y-axis direction
Specifies an increment (distance from measurement point [3] to measurement point [4]) in the Y-axis direction.
- F: Movement speed
Specifies the speed at which the probe is to move for measurement.
- W: Workpiece coordinate system
Select a workpiece coordinate system to be set up, and enter the corresponding number listed below:
G54 to G59: 1 = G54, 2 = G55, 3 = G56, 4 = G57, 5 = G58, and 6 = G59
If 48 coordinate systems are valid, the following numbers are specified to select desired workpiece coordinate systems:
G54.1P1 to P48: 1001 = G54P1, 1002 = G54P2, ..., 1048 = G54P48

NOTE

Before issuing a command for this cycle, be sure to set the probe to an approximate measurement start point.

Measurement sequence:

- 1) The probe moves at the speed f_a to a point the distance " $U - \alpha - \text{stylus ball radius}$ " away from the measurement start point.
- 2) The probe moves at the speed f in the range " $U + \gamma - \text{stylus ball radius}$ " until it touches the measurement face (the first measurement session).
- 3) The probe returns through the distance β at the rapid traverse rate.
- 4) The probe moves at the specified speed F in the range " $\beta + \gamma$ " until it touches the measurement face (the second measurement session).
- 5) The probe returns through the distance ϵ at the rapid traverse rate.
- 6) The probe moves to measurement points [2], [3], and [4] and makes the same measurement as stated above at each of these measurement points.

Executing G187 obtains the corner position from measured values, and outputs the obtained values to the W-specified workpiece zero point offset value and the following macro variables:

- #250: Corner X coordinate (machine coordinate system)
- #251: Corner Y coordinate (machine coordinate system)
- #252: Corner X coordinate (workpiece coordinate system)
- #253: Corner Y coordinate (workpiece coordinate system)

• **Measuring an inside corner (G188)**

The position of an inside corner is measured by creating a G code program in the following format:

G188C_A_B_U_V_I_J_F_W_ ;

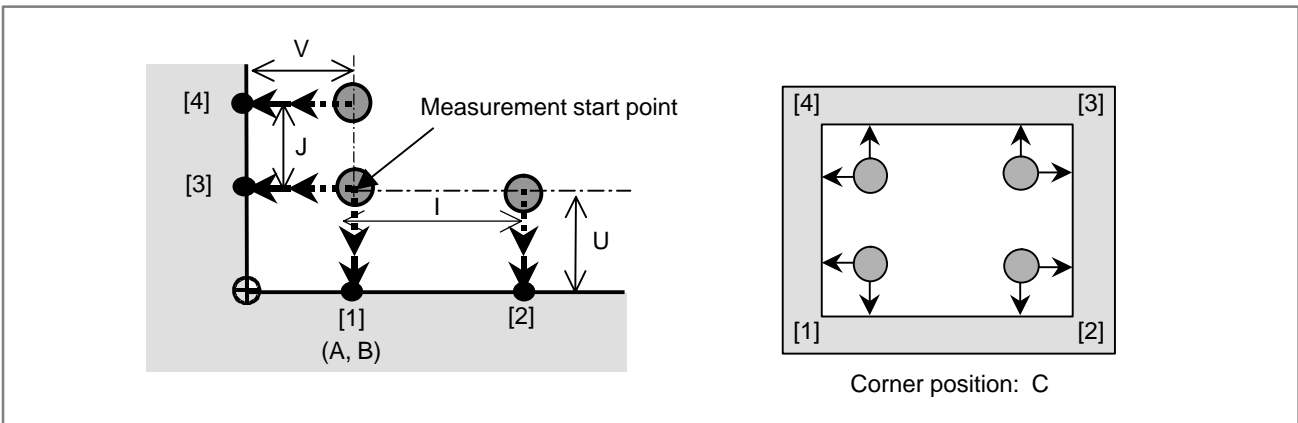

- C: Corner position
Specifies the corner position to be measured (1 to 4).
- A: X coordinate of measurement point 1
Specifies the X coordinate of measurement point 1.
- B: Y coordinate of measurement point 1
Specifies the Y coordinate of measurement point 1.
- U: Distance in the X-axis direction
Specifies the distance from the measurement start point to the measurement end face in the X-axis direction.

- V: Distance in the Y-axis direction
Specifies the distance from the measurement start point to the measurement end face in the Y-axis direction.
- I: Increment in the X-axis direction
Specifies an increment (distance from measurement point [1] to measurement point [2]) in the X-axis direction.
- J: Increment in the Y-axis direction
Specifies an increment (distance from measurement point [3] to measurement point [4]) in the Y-axis direction.
- F: Movement speed
Specifies the speed at which the probe is to move for measurement.
- W: Workpiece coordinate system
Select a workpiece coordinate system to be set up, and enter the corresponding number listed below:
G54 to G59: 1 = G54, 2 = G55, 3 = G56, 4 = G57, 5 = G58, and 6 = G59
If 48 coordinate systems are valid, the following numbers are specified to select desired workpiece coordinate systems:
G54.1P1 to P48: 1001 = G54P1, 1002 = G54P2, ..., 1048 = G54P48

NOTE

Before issuing a command for this cycle, be sure to set the probe to an approximate measurement start point.

Measurement sequence:

- 1) The probe moves at the speed f_a to a point the distance " $U - \alpha - \text{stylus ball radius}$ " away from the measurement start point.
- 2) The probe moves at the speed f in the range " $U + \gamma - \text{stylus ball radius}$ " until it touches the measurement face (the first measurement session).
- 3) The probe returns through the distance β at the rapid traverse rate.
- 4) The probe moves at the specified speed F in the range " $\beta + \gamma$ " until it touches the measurement face (the second measurement session).
- 5) The probe moves to measurement point [2], [3], and [4] and makes the same measurement as stated above at each of these measurement points.

Executing G188 obtains the corner position from measured values, and outputs the obtained values to the W-specified workpiece zero point offset value and the following macro variables:

- #250: Corner X coordinate (machine coordinate system)
- #251: Corner Y coordinate (machine coordinate system)
- #252: Corner X coordinate (workpiece coordinate system)
- #253: Corner Y coordinate (workpiece coordinate system)

● **Measuring a bolt hole circle (G189)**

The center position and radius of a bolt hole circle (for three holes) are measured by creating a G code program in the following format:

G189Z_R_D_A_B_C_F_W_ ;

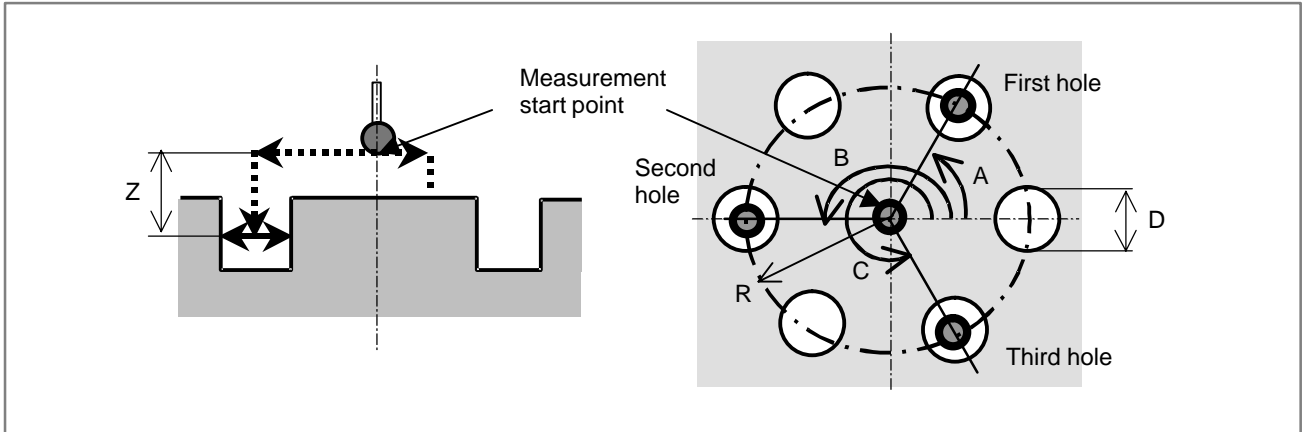

Z: Height along the Z-axis

Specifies the distance from the measurement start point to the measurement point along the Z-axis.

R: Radius

Specifies the radius of a bolt hole circle.

D: Nominal hole diameter

Specifies the nominal diameter of bolt holes.

A: First-hole angle

Specifies how far (in degrees) the center of the first bolt hole is away from the X-axis (0 degrees).

B: Second-hole angle

Specifies how far (in degrees) the center of the second bolt hole is away from the X-axis (0 degrees).

C: Third-hole angle

Specifies how far (in degrees) the center of the third bolt hole is away from the X-axis (0 degrees).

F: Movement speed

Specifies the speed at which the probe is to move for measurement.

W: Workpiece coordinate system

Select a workpiece coordinate system to be set up, and enter the corresponding number listed below:

G54 to G59: 1 = G54, 2 = G55, 3 = G56, 4 = G57, 5 = G58, and 6 = G59

If 48 coordinate systems are valid, the following numbers are specified to select desired workpiece coordinate systems:

G54.1P1 to P48: 1001 = G54P1, 1002 = G54P2, ..., 1048 = G54P48

NOTE

Before issuing a command for this cycle, be sure to set the probe above the approximate center of the bolt hole circle.

Measurement sequence:

- 1) The probe moves to the center of the first bolt hole at the speed f_a .
- 2) The probe moves at the speed f_a in the negative Z -axis direction to a point the distance Z away from the measurement start point.
- 3) The probe moves at the speed f_a in the positive X -axis direction to a point the distance " $D/2 - \alpha - \text{stylus ball radius}$ " away from the measurement start point.
- 4) The probe moves at the speed f in the range " $D/2 + \gamma - \text{stylus ball radius}$ " until it touches the measurement face.
- 5) The probe moves at the rapid traverse rate to the center X coordinate where it was before the start of measurement, and makes the same measurement as stated above in the negative X -axis direction and the Y -axis direction (the first measurement session).
- 6) The probe moves at the speed f_a in the positive X -axis direction to a point the distance " $\text{first-measurement session measurement position} - \beta$ " away from the measurement start point.
- 7) The probe moves at the specified speed F in the range " $\beta + \gamma$ " until it touches the measurement face.
- 8) The probe makes the same measurement as stated above in the negative X -axis direction and the Y -axis direction to obtain the center position of the first bolt hole (the second measurement session).
- 9) The probe makes the same measurement as stated above for the second bolt hole to obtain its center position.
- 10) The probe makes the same measurement as stated above for the third bolt hole to obtain its center position.

Executing G189 obtains the center of the bolt hole circle and its radius from measured values, and outputs the obtained values to the W -specified workpiece zero point offset value and the following macro variables:

- #250: Center X coordinate of the bolt hole circle (machine coordinate system)
- #251: Center Y coordinate of the bolt hole circle (machine coordinate system)
- #252: Center X coordinate of the bolt hole circle (workpiece coordinate system)
- #253: Center Y coordinate of the bolt hole circle (workpiece coordinate system)
- #254: Radius of the bolt hole circle

● **Measuring four holes (G190)**

The center position of each of four holes is measured by creating a G code program in the following format:

```
G190Z_D_A_B_C_E_H_I_J_K_F_W_;
```

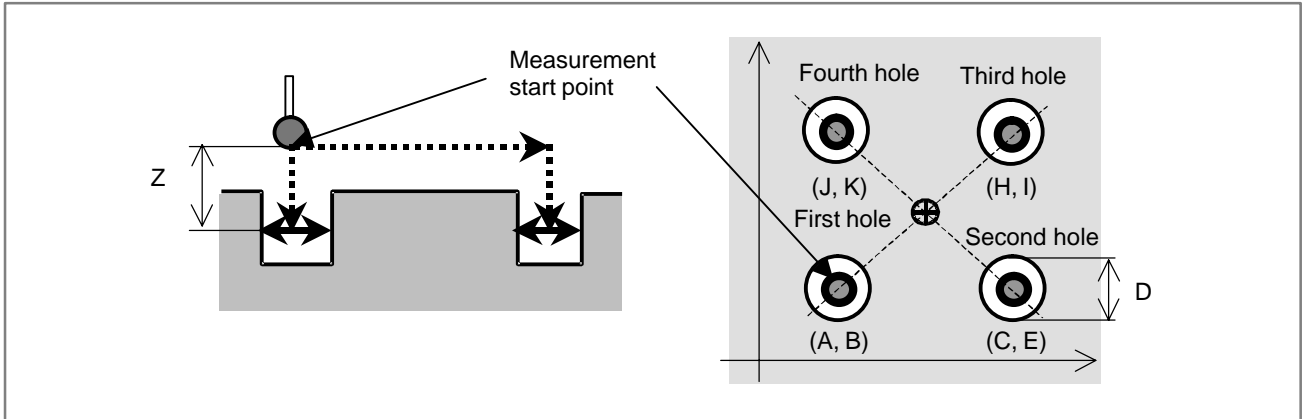

Z: Height along the Z-axis

Specifies the distance from the measurement start point to the measurement point along the Z-axis.

D: Nominal hole diameter

Specifies the nominal diameter of holes.

A: First-hole center X coordinate

Specifies the center X coordinate of the first hole.

B: First-hole center Y coordinate

Specifies the center Y coordinate of the first hole.

C: Second-hole center X coordinate

Specifies the center X coordinate of the second hole.

E: Second-hole center Y coordinate

Specifies the center Y coordinate of the second hole.

H: Third-hole center X coordinate

Specifies the center X coordinate of the third hole.

I: Third-hole center Y coordinate

Specifies the center Y coordinate of the third hole.

J: Fourth-hole center X coordinate

Specifies the center X coordinate of the fourth hole.

K: Fourth-hole center Y coordinate

Specifies the center Y coordinate of the fourth hole.

F: Movement speed

Specifies the speed at which the probe is to move for measurement.

W: Workpiece coordinate system

Select a workpiece coordinate system to be set up, and enter the corresponding number listed below:

G54 to G59: 1 = G54, 2 = G55, 3 = G56, 4 = G57, 5 = G58, and 6 = G59

If 48 coordinate systems are valid, the following numbers are specified to select desired workpiece coordinate systems:

G54.1P1 to P48: 1001 = G54P1, 1002 = G54P2, ..., 1048 = G54P48

NOTE

Before issuing a command for this cycle, be sure to set the probe above the approximate center of the first hole.

Measurement sequence:

- 1) The probe moves to the center of the first hole at the speed f_a .
- 2) The probe moves at the speed f_a in the negative Z-axis direction to a point the distance Z away from the measurement start point.
- 3) The probe moves at the speed f_a in the positive X-axis direction to a point the distance " $D/2 - \alpha - \text{stylus ball radius}$ " away from the measurement start point.
- 4) The probe moves at the speed f in the range " $D/2 + \gamma - \text{stylus ball radius}$ " until it touches the measurement face.
- 5) The probe moves at the rapid traverse rate to the center X coordinate where it was before the start of measurement, and makes the same measurement as stated above in the negative X-axis direction and the Y-axis direction (the first measurement session).
- 6) The probe moves at the speed f_a in the positive X-axis direction to a point the distance " $\text{first-measurement session measurement position} - \beta$ " away from the measurement start point.
- 7) The probe moves at the specified speed F in the range " $\beta + \gamma$ " until it touches the measurement face.
- 8) The probe makes the same measurement as stated above in the negative X-axis direction and the Y-axis direction to obtain the center position of the first hole (the second measurement session).
- 9) The probe makes the same measurement as stated above for the second hole to obtain its center position.
- 10) The probe makes the same measurement as stated above for the third hole to obtain its center position.
- 11) The probe makes the same measurement as stated above for the fourth hole to obtain its center position.

Executing G190 obtains the center of each of four holes from measured values, and outputs the obtained values to the W-specified workpiece zero point offset value and the following macro variables:

- #250: Center X coordinate of the four holes (machine coordinate system)
- #251: Center Y coordinate of the four holes (machine coordinate system)
- #252: Center X coordinate of the four holes (workpiece coordinate system)
- #253: Center Y coordinate of the four holes (workpiece coordinate system)

● **Measuring a workpiece angle (G191)**

The angle formed by one side of a workpiece and the X-axis is measured by creating a G-code program in the following format:

G191A_B_C_I_D_J_F_ ;

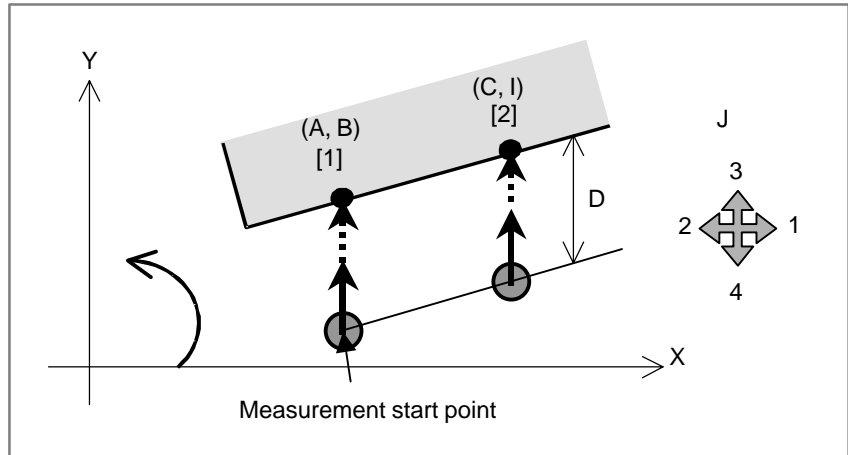

- A: X coordinate of measurement point 1
Specifies the X coordinate of measurement point 1.
- B: Y coordinate of measurement point 1
Specifies the Y coordinate of measurement point 1.
- C: X coordinate of measurement point 2
Specifies the X coordinate of measurement point 2.
- I: Y coordinate of measurement point 2
Specifies the Y coordinate of measurement point 2.
- D: Movement distance
Specifies the distance from the measurement start point to the measurement end face.
- J: Probe measurement axis
Selects the axis along which the probe is to move as well as the direction in which the probe is to move.
- 1: Positive X-axis
2: Negative X-axis
3: Positive Y-axis
4: Negative Y-axis
- F: Movement speed
Specifies the speed at which the probe is to move for measurement.

NOTE

Before issuing a command for this cycle, be sure to set the probe to the approximate measurement start point for measurement point 1.

Measurement sequence:

- 1) The probe moves at the speed f_a to a point the distance " $D - \alpha - \text{stylus ball radius}$ " away from the measurement start point.
- 2) The probe moves at the speed f in the range " $D + \gamma - \text{stylus ball radius}$ " until it touches the measurement face (the first measurement session).
- 3) The probe returns through the distance β at the rapid traverse rate.

- 4) The probe moves at the specified speed F in the range " $\beta + \gamma$ " until it touches the measurement face (the second measurement session).
- 5) The probe returns through the distance ε at the rapid traverse rate.
- 6) The probe makes the same measurement as stated above for measurement point [2].

Executing G191 obtains the angle one side of the workpiece makes with the X-axis from measured values, and outputs the obtained values to the following macro variables:

#250: Angle to which the workpiece tilts from the X-axis.

- **Measuring the angle related to two holes (G192)**

The angle formed by the line that passes through the centers of two holes and the X-axis is measured by creating a G-code program in the following format:

G192Z_D_A_B_C_I_F ;

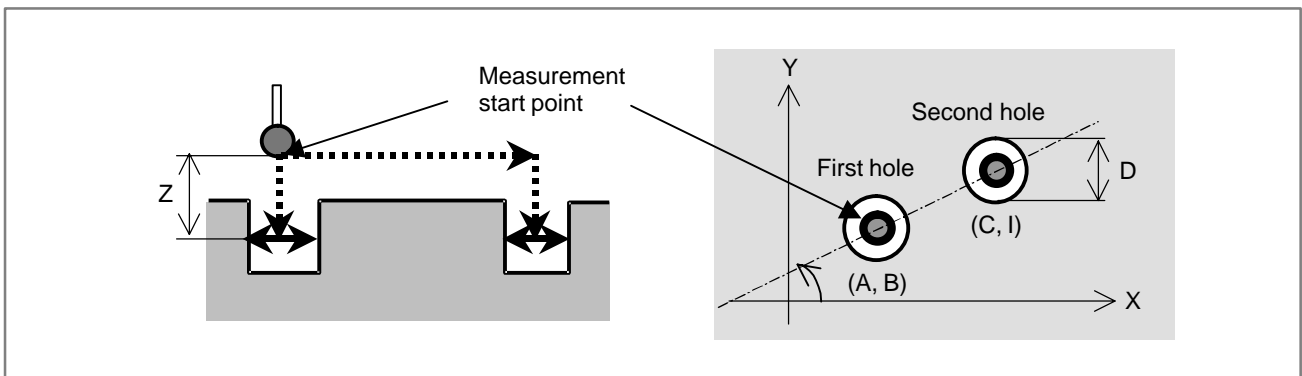

Z: Height along the Z-axis

Specifies the distance from the measurement start point to the measurement point along the Z-axis.

D: Nominal hole diameter

Specifies the nominal diameter of holes.

A: First-hole center X coordinate

Specifies the center X coordinate of the first hole.

B: First-hole center Y coordinate

Specifies the center Y coordinate of the first hole.

C: Second-hole center X coordinate

Specifies the center X coordinate of the second hole.

I: Second-hole center Y coordinate

Specifies the center Y coordinate of the second hole.

F: Movement speed

Specifies the speed at which the probe is to move for measurement.

NOTE

Before issuing a command for this cycle, be sure to set the probe above the approximate center of the first hole.

Measurement sequence:

- 1) The probe moves to the center of the first hole at the speed f_a .
- 2) The probe moves at the speed f_a in the negative Z-axis direction to a point the distance Z away from the measurement start point.

- 3) The probe moves at the speed f_a in the positive X-axis direction to a point the distance " $D/2 - \alpha - \text{stylus ball radius}$ " away from the measurement start point.
- 4) The probe moves at the speed f in the range " $D/2 + \gamma - \text{stylus ball radius}$ " until it touches the measurement face.
- 5) The probe moves at the rapid traverse rate to the center X coordinate where it was before the start of measurement, and makes the same measurement as stated above in the negative X-axis direction and the Y-axis direction (the first measurement session).
- 6) The probe moves at the speed f_a in the positive X-axis direction to a point the distance " $\text{first-measurement session measurement position} - \beta$ " away from the measurement start point.
- 7) The probe moves at the specified speed F in the range " $\beta + \gamma$ " until it touches the measurement face.
- 8) The probe makes the same measurement as stated above in the negative X-axis direction and the Y-axis direction to obtain the center position of the first hole (the second measurement session).
- 9) The probe makes the same measurement as stated above for the second hole to obtain its center position.

Executing G192 obtains the angle one side of the workpiece makes with the X-axis from measured values, and outputs the obtained value to the following macro variable:

#250: Angle formed by the line that passes through the centers of two holes and the X-axis

Caution

NOTE

- 1 Using this function requires the following options:
 - Embedded macro
 - Custom macro B
- 2 This function consists of 30 programs.
- 3 This function uses common variables #200 to #290.
- 4 This function uses program Nos. 9170 to 9199.
- 5 This function uses G codes, G170 to G173 and G180 to G192, to call macros. Of alarm Nos. 3000 to 3999, which can be generated by custom macros, alarm Nos. 3101 to 3149 are used. (See explanations about system variable #3000.) When using this function, avoid using these G codes and alarm numbers together with other custom macros.
- 6 The FS15 tape format cannot be used.
- 7 When specifying arguments, as a rule, arrange them in the sequence stated in this manual.
Arguments I, J, and K, especially, must be specified in the stated sequence.
- 8 Plane selection is not supported. Only the X-Y plane can be used.
- 9 When an argument is specified, a decimal point must be included as required.
- 10 This function cannot be used simultaneously with the manual guide, which provides an equivalent function.

Parameter

This measurement cycle can direct the probe in a specific orientation. On a machine provided with the spindle orientation function, set an M code in the following parameter.

12050	M code number for measurement cycle spindle orientation
-------	---

[Data type] Two-word

[Valid data range] 0 to 9999

Alarm and message

Number	Message	Description
3101	SETTING DATA ERROR. ADD. A	Address A or the data that should follow it has not been entered. Alternatively, the entered data is incorrect.
3102	SETTING DATA ERROR. ADD. B	Address B or the data that should follow it has not been entered. Alternatively, the entered data is incorrect.
3103	SETTING DATA ERROR. ADD. C	Address C or the data that should follow it has not been entered. Alternatively, the entered data is incorrect.
3104	SETTING DATA ERROR. ADD. I	Address I or the data that should follow it has not been entered. Alternatively, the entered data is incorrect.
3105	SETTING DATA ERROR. ADD. J	Address J or the data that should follow it has not been entered. Alternatively, the entered data is incorrect.
3106	SETTING DATA ERROR. ADD. K	Address K or the data that should follow it has not been entered. Alternatively, the entered data is incorrect.
3107	SETTING DATA ERROR. ADD. D	Address D or the data that should follow it has not been entered. Alternatively, the entered data is incorrect.
3108	SETTING DATA ERROR. ADD. E SETTING DATA ERROR. ADD. E	Address E or the data that should follow it has not been entered. Alternatively, the entered data is incorrect.
3109	SETTING DATA ERROR. ADD. F	Address F or the data that should follow it has not been entered. Alternatively, the entered data is incorrect.
3111	SETTING DATA ERROR. ADD. H	Address H or the data that should follow it has not been entered. Alternatively, the entered data is incorrect.
3113	SETTING DATA ERROR. ADD. M	Address M or the data that should follow it has not been entered. Alternatively, the entered data is incorrect.
3117	SETTING DATA ERROR. ADD. Q	Address Q or the data that should follow it has not been entered. Alternatively, the entered data is incorrect.
3118	SETTING DATA ERROR. ADD. R	Address R or the data that should follow it has not been entered. Alternatively, the entered data is incorrect.
3119	SETTING DATA ERROR. ADD. S	Address S or the data that should follow it has not been entered. Alternatively, the entered data is incorrect.
3120	SETTING DATA ERROR. ADD. T	Address T or the data that should follow it has not been entered. Alternatively, the entered data is incorrect.

Number	Message	Description
3121	SETTING DATA ERROR. ADD. U	Address U or the data that should follow it has not been entered. Alternatively, the entered data is incorrect.
3122	SETTING DATA ERROR. ADD. V	Address V or the data that should follow it has not been entered. Alternatively, the entered data is incorrect.
3123	SETTING DATA ERROR. ADD. W	Address W or the data that should follow it has not been entered. Alternatively, the entered data is incorrect.
3124	SETTING DATA ERROR. ADD. X	Address X or the data that should follow it has not been entered. Alternatively, the entered data is incorrect.
3125	SETTING DATA ERROR. ADD. Y	Address Y or the data that should follow it has not been entered. Alternatively, the entered data is incorrect.
3126	SETTING DATA ERROR. ADD. Z	Address Z or the data that should follow it has not been entered. Alternatively, the entered data is incorrect.
3130	ERROR: PROBE LENGTH	The length (#200) of the probe has not been entered.
3131	ERROR: STYLUS BALL DIAM. X	The diameter of the stylus ball in the X-axis direction (#201) has not been entered.
3132	ERROR: STYLUS BALL DIAM. Y	The diameter of the stylus ball in the Y-axis direction (#202) has not been entered.
3133	ERROR: STYLUS BALL OFS. X	The compensation amount for the stylus ball in the X-axis direction (#203) has not been entered.
3134	ERROR: STYLUS BALL OFS. Y	The compensation amount for the stylus ball in the Y-axis direction (#204) has not been entered.
3135	ERROR: MEASURING 1ST FEED	The speed at which the probe is to move in the first measurement session (#210) has not been entered.
3136	ERROR: MEASURING 1ST DIST.	The approach value to be used in the first measurement session (#211) has not been entered.
3137	ERROR: MEASURING 2ND DIST.	The return value to be used in the first measurement session (#212) has not been entered.
3138	ERROR: MEASURING OVERLAP	The distance through which the probe is to advance beyond the measurement face (#213) has not been entered.
3139	ERROR: FEED FOR APPROACH	The speed at which the probe moves to the measurement start point (#214) has not been entered.

Number	Message	Description
3140	ERROR: ESCAPE OFFSET	The return value to be used after the probe touches the measurement face in the second measurement session (#215) has not been entered.
3141	CHECK SENSOR SIGNAL	Check the sensor signal.
3142	NO TOUCH	The probe is not in contact with the workpiece.
3143	PROBE TOUCHED WHILE APPR.	The probe touched the workpiece when it was approaching.
3148	PARAM.NO.12050 IS UNDEF.	Parameter No. 12050 has not been set up.
3149	NO OPTION	The measurement cycle option is unavailable.

11.7 CANNED CYCLE (M SERIES)/CANNED CYCLE FOR DRILLING (T SERIES)

General

Canned cycles make it easier for the programmer to create programs. With a canned cycle, a frequently-used machining operation can be specified in a single block with a G function; without canned cycles, normally more than one block is required. In addition, the use of canned cycles can shorten the program to save memory.

Explanations

A canned cycle consists of a sequence of six operations.

- Operation 1 Positioning a hole position
- Operation 2 Rapid traverse up to point R level
- Operation 3 Hole machining
- Operation 4 Operation at the bottom of a hole
- Operation 5 Retraction to point R level
- Operation 6 Rapid traverse up to the initial point

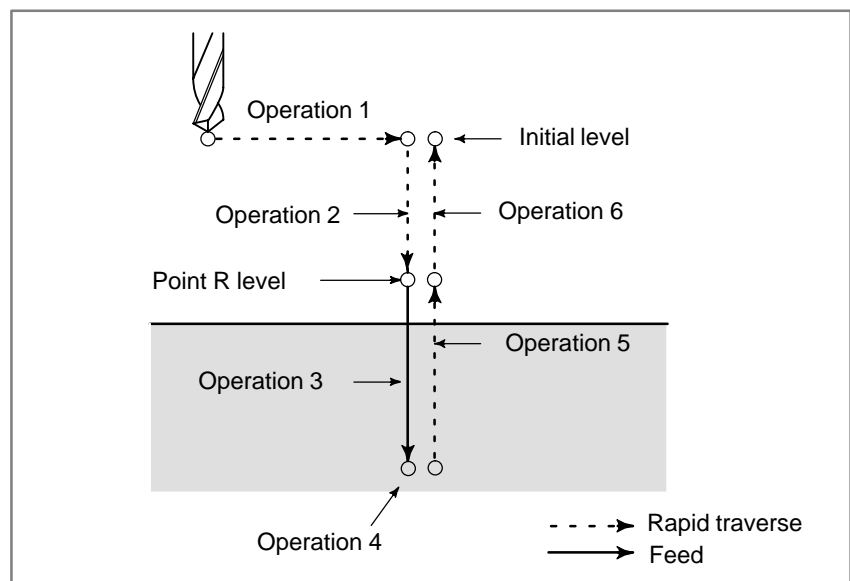

Fig. 11.7 (a) Canned cycle operation sequence

SPINDLE CONTROL

In some canned cycles, a spindle command to rotate the spindle in reverse direction may be output.

The following canned cycles require spindle control:

M series	T series
Reverse tapping cycle G74	Face tapping cycle (G84)
Fine boring cycle G76	Side tapping cycle (G88)
Tapping cycle G84	
Boring cycle G86	
Back boring cycle G87	
Boring cycle G88	

For spindle control, the following normal miscellaneous functions are used:

See the description of the miscellaneous functions.

M03: CW spindle rotation

M04: CCW spindle rotation

M05: Spindle stop

M19: Spindle orientation (M series)

When the rotation direction of the spindle is to be switched from one direction to the other (for example, when M04 is output during M03 operation), a parameter can specify whether to send M05 at the time switching.

Timing charts are described in the following page:

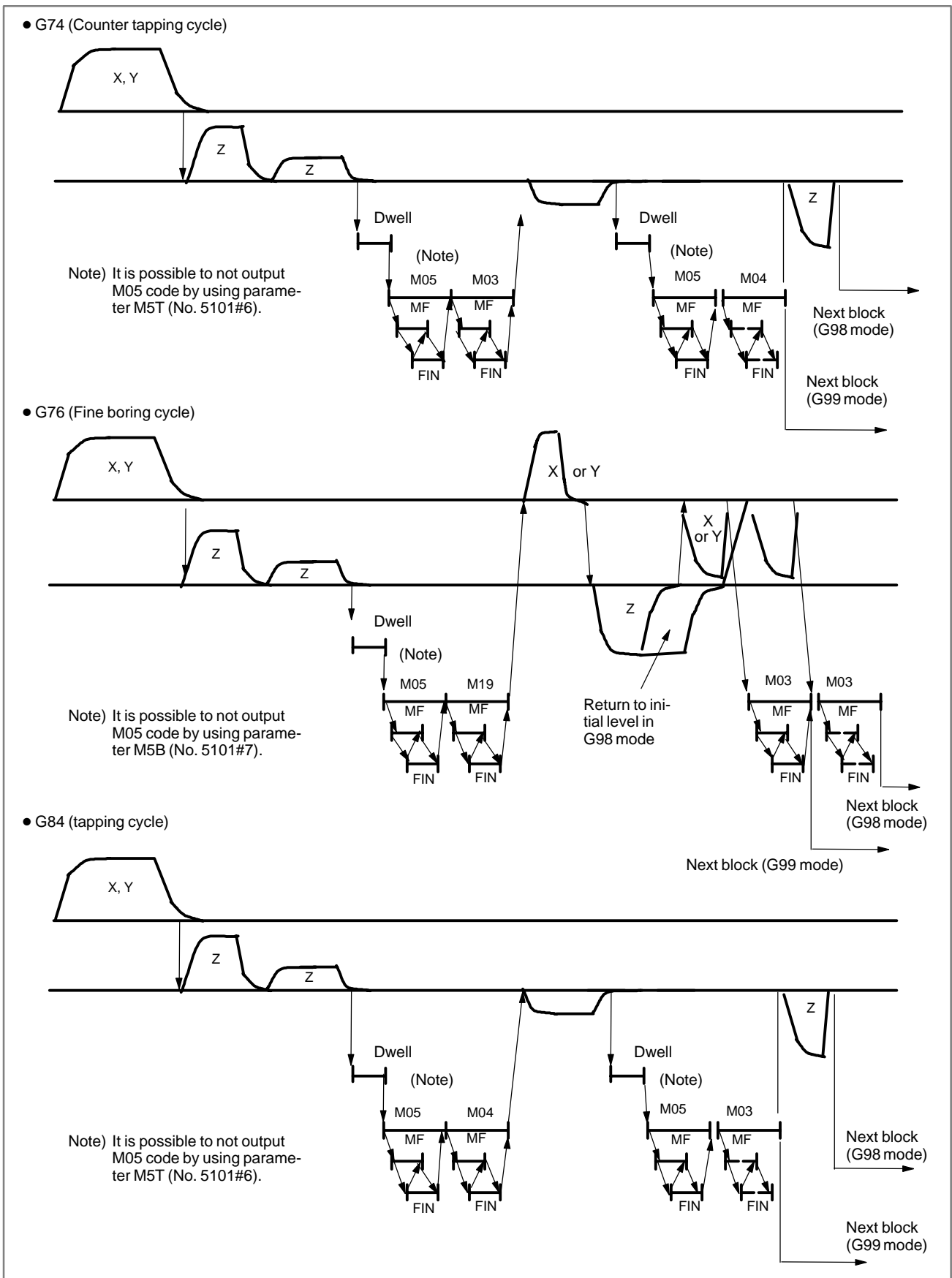

Fig. 11.7 (b) Canned cycle for M series (1/2)

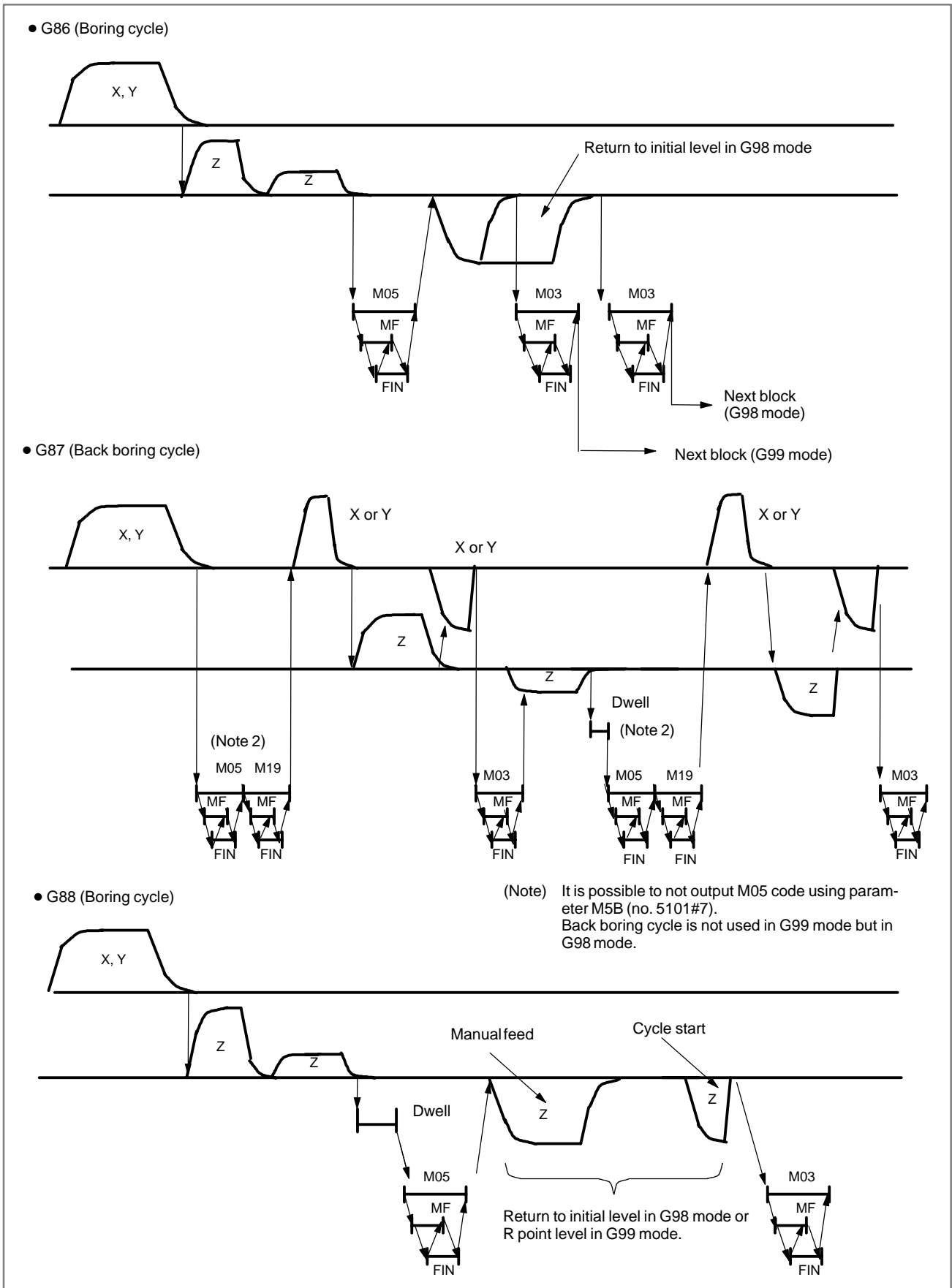

Fig. 11.7 (c) Canned cycle for M series (2/2)

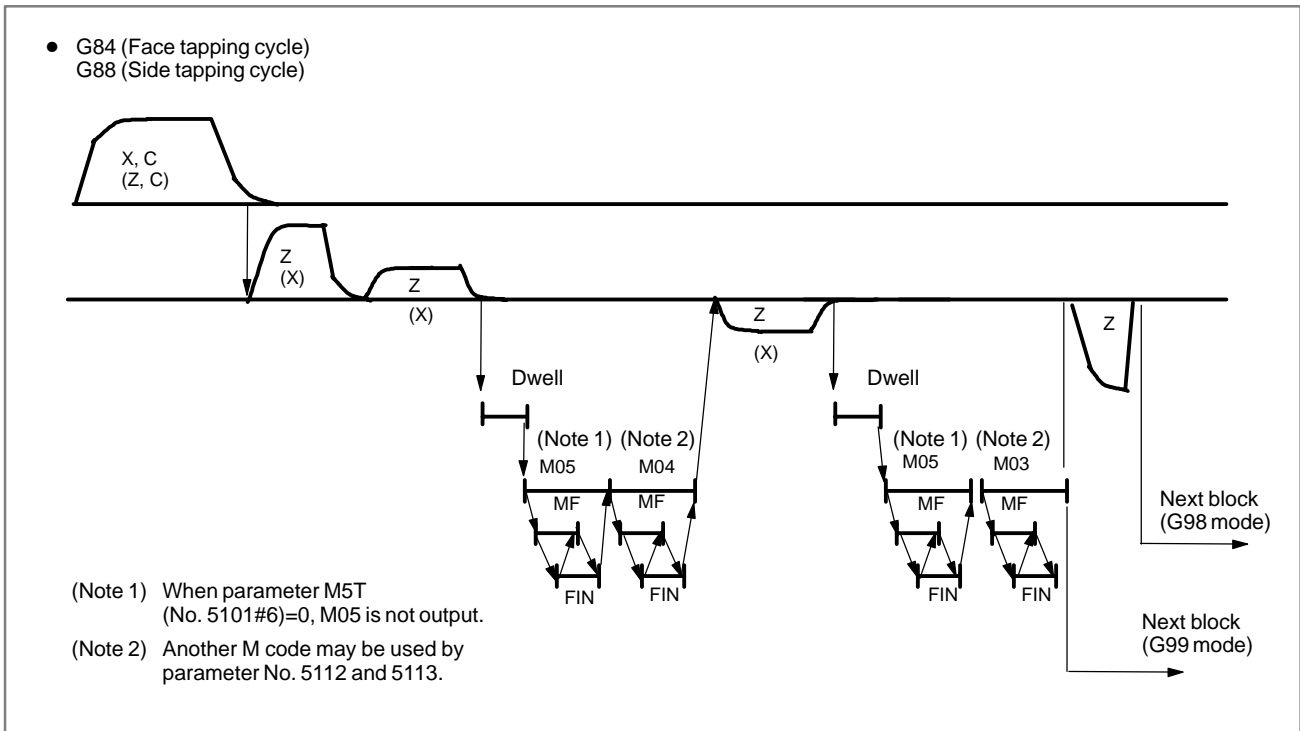

Fig 11.7 (d) Canned cycle for T series

• **M code used for C-axis clamp/unclamp (T series)**

When an M code specified in parameter No.5110 for C-axis clamp/unclamp is programmed, the CNC issues the M code for C-axis clamp after the tool is positioned and before the tool is fed in rapid traverse to the point-R level. The CNC also issues the M code (M code C-axis clamp +1) for C-axis unclamp after the tool retracts to the point-R level. The tool dwells for the time specified in parameter No. 5111.

Tapping signal

During a tapping cycle, the tapping signal is output. The tapping signal is also output while the G code of the tapping cycle is valid.

Override

During tapping, cutting feedrate override is always set to 100%.

Feed hold

When the feed hold key is pressed during tapping, the movement is not stopped immediately but the movement is stopped when the tool is returned to level R.

Dry run

The TDR bit (bit 5 of parameter No. 1401) specifies whether dry run is valid during tapping.

Signal

Tapping signal TAP <F001#5>

[Classification] Output signal

[Function] Reports that the system is in tapping mode.

[Output condition] The signal is set to 1 when:

- The system is in tapping cycle mode.
G74, G84: M series
G84, G88: T series
- The system is in tapping mode.
G63: M series

The signal is set to 0 when:

- The system is in neither tapping cycle mode nor tapping mode.
- A reset or emergency stop is specified.

Signal address

	#7	#6	#5	#4	#3	#2	#1	#0
F001			TAP					

Parameter

	#7	#6	#5	#4	#3	#2	#1	#0
5101		M5T			ILV	RTR		FXY
	M5B	M5T	RD2	RD1			EXC	FXY

[Data type] Bit

FXY The drilling axis in the drilling canned cycle is:

- 0 : Always the Z-axis
- 1 : The axis selected by the program

NOTE

In the case of the T series, this parameter is valid only for the drilling canned cycle in the Series 15 format.

EXC G81

- 0 : Specifies a drilling canned cycle
- 1 : Specifies an external operation command

RTR G83 and G87

- 0 : Specify a high-speed peck drilling cycle
- 1 : Specify a peck drilling cycle

ILV Initial point position in drilling canned cycle

- 0 : Not updated by reset
- 1 : Updated by reset

RD2, RD1 Set the axis and direction in which the tool in drilling canned cycle G76 or G87 is got free. RD2 and RD1 are set as shown below by plane selection.

RD2	RD1	G17	G18	G19
0	0	+X	+Z	+Y
0	1	-X	-Z	-Y
1	0	+Y	+X	+Z
1	1	-Y	-X	-Z

M5T When a spindle rotates from the forward to the reverse direction and vice versa in tapping cycles G84 and G74 for M series (G84 and G88 for T series), before M04 or M03 is output:

For T series

0 : Not output M05

1 : Outputs M05

For M series

0 : Outputs M05

1 : Not output M05

M5B In drilling canned cycles G76 and G87:

0 : Outputs M05 before an oriented spindle stops

1 : Not output M05 before an oriented spindle stops

	#7	#6	#5	#4	#3	#2	#1	#0
5102	RDI	RAB						

[Data type] Bit

RAB The R command for the drilling canned cycle in the Series 15 format is:

0 : Regarded as an incremental command

1 : Regarded as:

An absolute command in the case of G code system A

An absolute command in the case of G code system B or C when the G90 mode is specified.

An incremental command in the case of G code system B or C when the G91 mode is specified.

RDI The R command for the drilling canned cycle in the Series 15 format:

0 : Is regarded as the specification of a radius

1 : Follows the specification of a diameter/radius for the drilling axis

	#7	#6	#5	#4	#3	#2	#1	#0
5103								SIJ

[Data type] Bit

SIJ A tool shift value for the drilling canned cycle G76 or G87 is specified by:

0 : Address Q

1 : Address I, J, or K

5110	C-axis clamp M code in drilling canned cycle

[Data type] Byte

[Valid data range] 0 to 99

This parameter sets the C-axis clamp M code in a drilling canned cycle.

5111	Dwell time when C-axis unclamping is specified in drilling canned cycle

[Data type] Word

[Unit of data] ms

[Valid data range] 0 to 32767

This parameter sets the dwell time when C-axis unclamping is specified in a drilling canned cycle.

5112	Spindle forward-rotation M code in drilling canned cycle

[Data type] Byte

[Valid data range] 0 to 255

This parameter sets the spindle forward-rotation M code in a drilling canned cycle.

NOTE

M03 is output when "0" is set.

5113	Spindle reverse-rotation M code in drilling canned cycle

[Data type] Byte

[Valid data range] 0 to 255

This parameter sets the spindle reverse-rotation M code in a drilling canned cycle.

NOTE

M04 is output when "0" is set.

5114	Return or clearance value of drilling canned cycle G83
	Return value of high-speed peck drilling cycle G73

[Data type] Word

[Unit of data]	Increment system	IS-A	IS-B	IS-C	Unit
	Metric input	0.01	0.001	0.001	mm
	Inch input	0.001	0.0001	0.0001	inch

[Valid data range] 0 to 32767

For M series, this parameter sets the return value in high-speed peck drilling cycle G73 (G83 for T series).

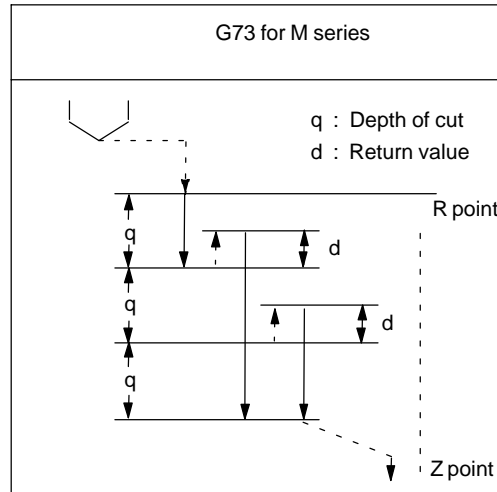

Fig. 11.7 (e) High-speed peck drilling cycle (G73) for M series

For T series, this parameter sets the return or clearance value in drilling canned cycle G83.

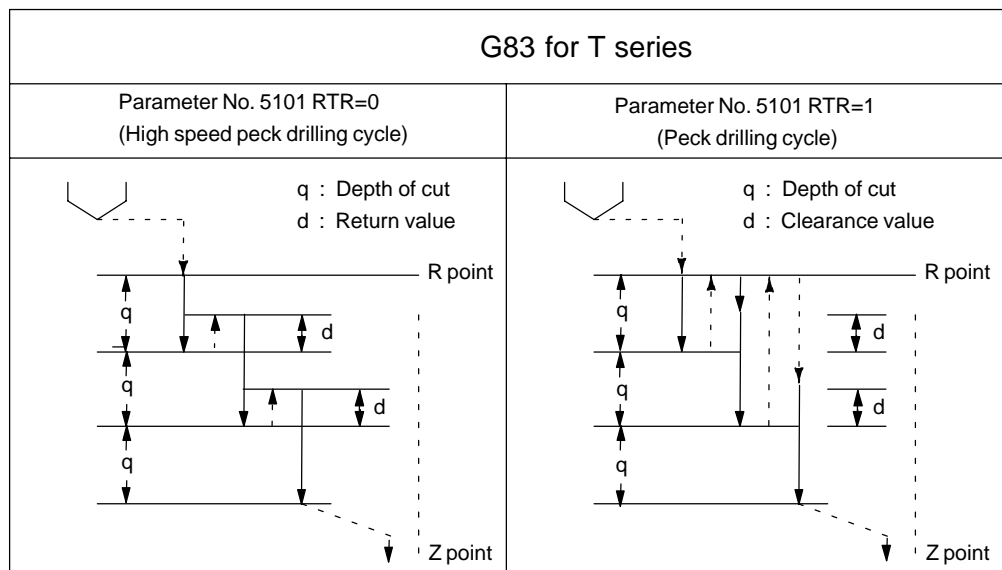

Fig. 11.7 (f) Drilling canned cycle (G83) for T series

5115	
	Clearance canned cycle G83

[Data type] Word

[Unit of data]	Increment system	IS-A	IS-B	IS-C	Unit
	Metric input	0.01	0.001	0.001	mm
	Inch input	0.001	0.0001	0.0001	inch

[Valid data range] 0 to 32767

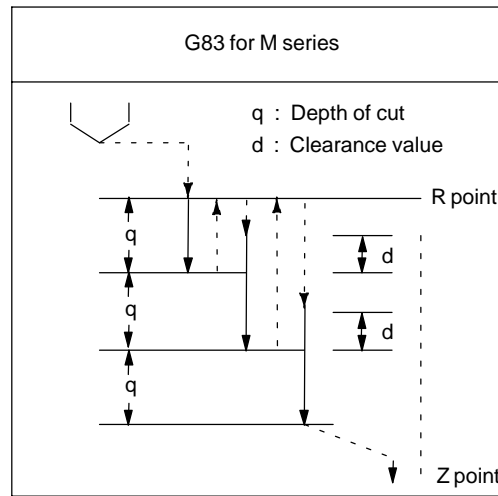

Fig. 11.7 (g) Peck drilling cycle (G83) for M series

Alarm and message

Number	Message	Description
044	G27-G30 NOT ALLOWED IN FIXED CYCLE (M series)	One of G27 to G30 is commanded in a canned cycle mode. Modify the program.

Note

NOTE
 A parameter FXY (No. 5101#0) can be set to the Z axis always used as the drilling axis. When FXY=0, the Z axis is always the drilling axis.

Reference item

Series 16 <i>i</i> /18 <i>i</i> /160 <i>i</i> /180 <i>i</i> / 160 <i>is</i> /180 <i>is</i>	OPERATOR'S MANUAL (For Machining Center) (B-63534EN)	II.13.1	Canned cycle
	OPERATOR'S MANUAL (For Lathe) (B-63524EN)	II.13.3	Canned cycle for hole machining
Series 21 <i>i</i> /210 <i>i</i> /210 <i>is</i>	OPERATOR'S MANUAL (For Machining Center) (B-63614EN)	II.13.1	Canned cycle
	OPERATOR'S MANUAL (For Lathe) (B-63604EN)	II.13.3	Canned cycle for hole machining
Series 20 <i>i</i>	OPERATOR'S MANUAL (For Manual Milling Machine) (B-64204EN)	II.13.1	Canned cycle

11.8 EXTERNAL MOTION FUNCTION (M SERIES)

General

Upon completion of positioning in each block in the program, an external operation function signal can be output to allow the machine to perform specific operation.

G81 IP_ ; (The IP_ is axis move command)

Every time positioning for the IP_ move command is completed, the CNC sends an external operation signal to the machine. An external operation signal is output for each positioning operation until canceled by G80 or a group 01 G code.

No external operation signals are output during execution of a block that contains neither X nor Y.

Basic procedure

- 1 Once positioning for a move command has been completed, the CNC sets the external operation signal EF to 1.
- 2 When the EF signal is set to 1, the PMC executes drilling or another operation. Once the operation has been completed, the PMC sets completion signal FIN to 1.
- 3 The CNC resets the EF signal to 0 upon the elapse of the time (TFIN) specified in parameter No. 3011 after the FIN signal is set to 1.
- 4 When the EF signal is set to 0, the PMC resets the FIN signal to 0.
- 5 The CNC starts executing the next block.

The timing diagram is shown below:

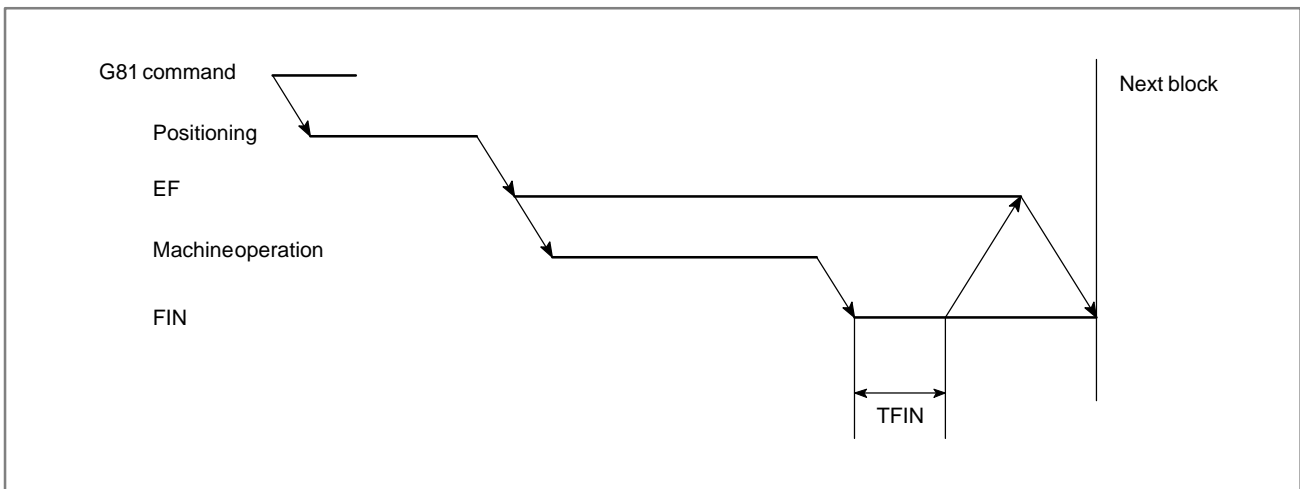

Fig. 11.8 Timing diagram of basic procedure

Signal

External Operation

Signal

EF<F008#0>

[Classification] Output signal

[Function] Reports that the positioning of G81 has been completed in the external motion function, and that a special external operation is required.

[Output condition] For details of the output condition and procedure, see the "basic procedure", described previously.
For details of completion signal FIN, see section 8.1.

Signal address

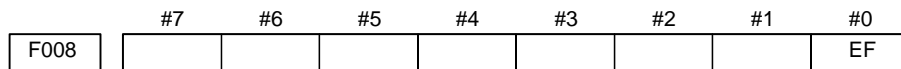

Parameter

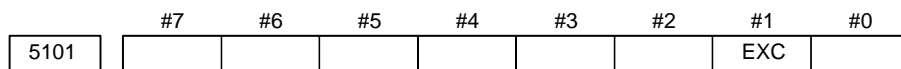

[Data type] Bit

EXC G81:

0 : Specifies a drilling canned cycle

1 : Specifies an external operation command

Caution

CAUTION

- 1 When this function is used, canned cycles (G73, G74, G76, and G82 to G89) cannot be used.
- 2 When the high-speed M, S, T, or B interface is used, the signals used by this function are transferred in high-speed mode. See Section 8.4.

Reference item

Series 16i/18i/160i/180i/ 160is/180is	OPERATOR'S MANUAL (For Machining Center) (B-63534EN)	II.13.8	External operation function (G81)
Series 21i/210i/210is	OPERATOR'S MANUAL (For Machining Center) (B-63614EN)	II.13.4	External operation function (G81)
Series 20i	OPERATOR'S MANUAL (For Manual Milling Machine) (B-64204EN)	II.13.4	External operation function (G81)

11.9 CANNED CYCLE (T SERIES)/MULTIPLE REPETITIVE CANNED CYCLE (T SERIES)

General

The option canned cycles makes CNC programming easy. For instance, the data of the finish work shape describes the tool path for rough machining. And also, a canned cycles for the thread cutting is available. The following example shows stock removals in turning type I. If a finished shape of A to A' to B is given by a program as in the figure below, the specified area is removed by Δd (depth of cut), with finishing allowance $\Delta u/2$ and Δw left.

Program command

(F) : Cutting feed
(R) : Rapid traverse

G71 U(Δd) R(e) ;
G71 P(ns) Q(nf) U(Δu) W(Δw) F(f) S(s) T(t)
 N(ns).....

 F _____
 S _____
 T _____
 N(nf).....;

The move command of a finished shape of A to A' to B is specified in the blocks from sequence number ns to nf.

Δd : Depth of cut (radius designation)
 Designate without sign. The cutting direction depends on the direction AA'. This designation is modal and is not changed until the other value is designated. Also this value can be specified by the parameter (No. 5132), and the parameter is changed by the program command.

e : Escaping amount
 This designation is modal and is not changed until the other value is designated. Also this value can be specified by the parameter (No. 5133), and the parameter is changed by the program command.

ns : Sequence number of the first block for the program of finishing shape.
 nf : Sequence number of the last block for the program of finishing shape.
 Δu : Distance and direction of finishing allowance in X direction (diameter / radius designation).
 Δw : Distance and direction of finishing allowance in Z direction.
 f,s,t : Any F, S, or T function contained in blocks ns to nf in the cycle is ignored, and the F, S, or T function in this G71 block is effective.

Signal

Chamfering signal CDZ<G053#7>

[Classification] Input signal

[Function] Executes chamfering in a threading cycle. Specify the chamfering distance in parameter No. 5130.

[Operation] When the signal is set to 1, chamfering is not executed in the threading cycle.
When the signal is set to 0, chamfering is executed in the threading cycle.

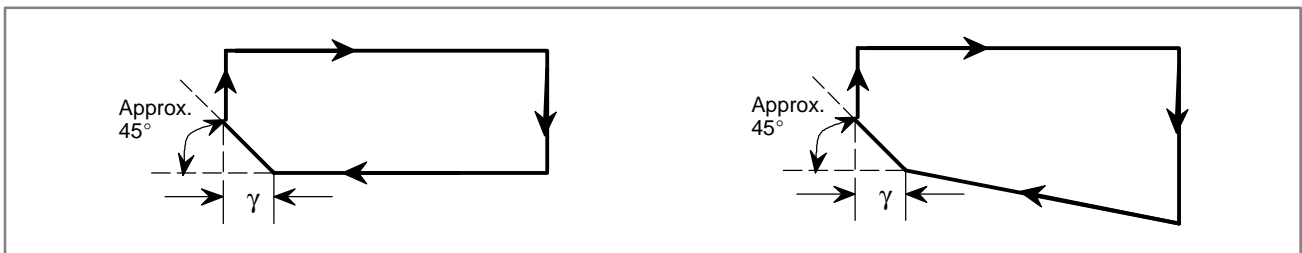

Fig. 11.9 (a) Straight thread cutting cycle

Fig. 11.9 (b) Taper thread cutting cycle

Set the chamfering distance γ to the parameter No. 5130. When the optional multiple repetitive canned cycle is provided, the chamfering distance can be specified in G76. The chamfering angle is made smaller than 45° by the remaining pulses in the automatic acceleration/deceleration circuit and servo system.

Signal address

	#7	#6	#5	#4	#3	#2	#1	#0
G053	CDZ							

Parameter

• Various setting for multiple repetitive canned cycle

	#7	#6	#5	#4	#3	#2	#1	#0
5102						QSR	MRC	

[Data type] Bit

MRC When a target figure other than a monotonically increasing or monotonically decreasing figure is specified in a multiple repetitive turning canned cycle (G71, G72):

0 : No alarm occurs.

1 : P/S alarm No. 064 is occurs.

NOTE

This parameter is valid for multiple repetitive turning canned cycle type I.

QSR Before a multiple repetitive canned cycle (G70 to G73) is started, a check to see if the program contains a block that has the sequence number specified in address Q is:

0 : Not made.

1 : Made. (If the sequence number specified in address Q cannot be found, an alarm occurs and the canned cycle is not executed.)

● **Chamfering distance in thread cutting cycles G76 and G92**

5130	Chamfering distance in thread cutting cycles G76 and G92
------	--

[Data type] Byte

[Unit of data] 0.1

[Valid data range] 0 to 127

This parameter sets the chamfering distance in thread cutting cycles G76 and G92.

● **Depth of cut in multiple repetitive canned cycles G71 and G72**

5132	Depth of cut in multiple repetitive canned cycles G71 and G72
------	---

[Data type] Two-word

[Unit of data]	Increment system	IS-B	IS-C	Unit
	Metric input	0.001	0.001	mm
	Inch input	0.0001	0.0001	inch

[Valid data range] 0 to 99999999

This parameter sets the depth of cut in multiple repetitive canned cycles G71 and G72.

● **Escape in multiple repetitive canned cycles G71 and G72.**

5133	Escape in multiple repetitive canned cycles G71 and G72.
------	--

[Data type] Two-word

[Unit of data]	Increment system	IS-B	IS-C	Unit
	Metric input	0.001	0.001	mm
	Inch input	0.0001	0.0001	inch

[Valid data range] 0 to 99999999

This parameter sets the escape in multiple repetitive canned cycles G71 and G72.

- **Escape in multiple repetitive canned cycles G73**

5135	Escape in multiple repetitive canned cycle G73 in X-axis direction
5136	Escape in multiple repetitive canned cycle G73 in Z-axis direction

[Data type] Two-word

[Unit of data]	Increment system	IS-B	IS-C	Unit
	Metric input	0.001	0.001	mm
	Inch input	0.0001	0.0001	inch

[Valid data range] 0 to 99999999

This parameter sets the escape in multiple repetitive canned cycle G73 of an X, then Z axis.

- **Division count in multiple repetitive canned cycle G73**

5137	Division count in multiple repetitive canned cycle G73
------	--

[Data type] Two-word

[Unit of data] Cycle

[Valid data range] 0 to 99999999

This parameter sets the division count in multiple repetitive canned cycle G73.

- **Return in multiple canned cycles G74 and G75**

5139	Return in multiple canned cycles G74 and G75
------	--

[Data type] Two-word

[Unit of data]	Increment system	IS-B	IS-C	Unit
	Metric input	0.001	0.001	mm
	Inch input	0.0001	0.0001	inch

[Valid data range] 0 to 99999999

This parameter sets the return in multiple repetitive canned cycles G74 and G75.

● **Minimum depth of cut in multiple repetitive canned cycle G76**

5140 Minimum depth of cut in multiple repetitive canned cycle G76

[Data type] Two-word

[Unit of data]	Increment system	IS-B	IS-C	Unit
	Metric input	0.001	0.001	mm
	Inch input	0.0001	0.0001	inch

[Valid data range] 0 to 99999999

This parameter sets the minimum depth of cut in multiple repetitive canned cycle G76.

● **Finishing allowance in multiple repetitive canned cycle G76**

5141 Finishing allowance in multiple repetitive canned cycle G76

[Data type] Two-word

[Unit of data]	Increment system	IS-B	IS-C	Unit
	Metric input	0.001	0.001	mm
	Inch input	0.0001	0.0001	inch

[Valid data range] 0 to 99999999

This parameter sets the finishing allowance in multiple repetitive canned cycle G76.

● **Repetition count of final finishing in multiple repetitive canned cycle G76**

5142 Repetition count of final finishing in multiple repetitive canned cycle G76

[Data type] Two-word

[Unit of data] Cycle

[Valid data range] 1 to 99999999

This parameter sets the repetition count in multiple repetitive canned cycle G76.

● **Tool nose angle in multiple repetitive canned cycle G76.**

5143 Tool nose angle in multiple repetitive canned cycle G76.

[Data type] Two-word

[Unit of data] Degree

[Valid data range] 0 to 120 when FS15 tape format is used
0, 29, 30, 55, 60 and 80 when FS15 tape format is not used.

This parameter sets the tool nose angle in multiple repetitive canned cycle G76.

Alarm and message

Number	Message	Description
061	ADDRESS P/Q NOT FOUND IN G70-G73	Address P or Q is not specified in G70, G71, G72, or G73 command. Modify the program.
062	ILLEGAL COMMAND IN G71-G76	<ol style="list-style-type: none"> 1 The depth of cut in G71 or G72 is zero or negative value. 2 The repetitive count in G73 is zero or negative value. 3 The negative value is specified to Δi or Δk in G74 or G75. 4 A value other than zero is specified to address U or W, though Δi or Δk is zero in G74 or G75. 5 A negative value is specified to Δd, though the relief direction in G74 or G75 is determined. 6 Zero or a negative value is specified to the height of thread or depth of cut of first time in G76. 7 The specified minimum depth of cut in G76 is greater than the height of thread. 8 An unusable angle of tool tip is specified in G76. Modify the program.
063	SEQUENCE NUMBER NOT FOUND	The sequence number specified by address P in G70, G71, G72, or G73 command cannot be searched. Modify the program.
064	SHAPE PROGRAM NOT MONOTONOUSLY	A target shape which is not monotone increase or decrease was specified in a repetitive canned cycle (G71 or G72).
065	ILLEGAL COMMAND IN G71-G73	<ol style="list-style-type: none"> 1 G00 or G01 is not commanded at the block with the sequence number which is specified by address P in G71, G72, or G73 command. 2. Address Z(W) or X(U) was commanded in the block with a sequence number which is specified by address P in G71 or G72, respectively. Modify the program.
066	IMPROPER G-CODE IN G71-G73	An unallowable G code was commanded between two blocks specified by address P in G71, G72, or G73. Modify the program.
067	CAN NOT ERROR IN MDI MODE	G70, G71, G72, or G73 command with address P and Q was specified. Modify the program.
069	FORMAT ERROR IN G70-G73	The final move command in the blocks specified by P and Q of G70, G71, G72, or G73 ended with chamfering or corner R.

Cautions for multiple repetitive canned cycle (G70 to G76)

- 1 Necessary parameters (such as P, Q, X, Z, U, W, and R) must be set correctly for an individual block that specifies a multiple repetitive canned cycle.
- 2 In G71, G72, and G73 blocks having a sequence number specified using P, always specify G00 or G01 in group 01, or otherwise a P/S alarm (No. 65) will be issued.
- 3 None of G70, G71, G72, and G73 can be specified in the MDI mode. If any of them is specified, a P/S alarm (No. 67) will be issued. G74, G75, and G76 can be specified, however.
- 4 M98/M99 cannot be specified in a G70, G71, G72, G73 block, or any block having a sequence number between those specified using P or Q in a G70, G71, G72, or G73 block.
- 5 The following commands cannot be specified in any block having a sequence number between those specified using P or Q in a G70, G71, G72, or G73 block.
 - One-shot G code except dwell (G04)
 - G code other than G00, G01, G02, or G03 in group 01
 - G codes in group 06
 - M98/M99
- 6 It is possible to stop operation during multiple repetitive canned cycle (G70 to G76) execution to allow manual intervention. Before restarting the multiple repetitive canned cycle, be sure to return the tool to the point of manual intervention, because the distance through which the tool is caused to move by manual intervention is not included in the absolute value (the actual tool position deviates by that distance).
- 7 When G70, G71, G72, or G73 is executed, P and Q cannot specify the same sequence number in one program.
- 8 For a multiple repetitive canned cycle, no figure can be specified using the direct drawing dimension programming or chamfering/corner rounding format.
- 9 Also for G74, G75, and G76, it is impossible to use floating-point input for P and Q. The unit of travel distance and cutting depth is the least input increment.
- 10 If #1 = 2500 is executed in a custom macro, 2500.000 is assigned to #1, and P#1 is equivalent to P2500.
- 11 It is impossible to apply tool-nose radius compensation in G71, G72, G73, G74, G75, G76, and G78.
- 12 A multiple repetitive canned cycle program cannot be used for DNC operation.
- 13 No interrupt-type custom macro can be used during multiple repetitive canned cycle execution.
- 14 No multiple repetitive canned cycle can be executed in the advanced preview control mode.

Reference item

Series 16 <i>i</i> /18 <i>i</i> /160 <i>i</i> /180 <i>i</i> / 160 <i>is</i> /180 <i>is</i>	OPERATOR'S MANUAL (For Lathe) (B-63524EN)	II.13.1 II.13.2	Canned cycle Multiple repetitive canned cycle
Series 21 <i>i</i> /210 <i>i</i> /210 <i>is</i>	OPERATOR'S MANUAL (For Lathe) (B-63604EN)	II.13.1 II.13.2	Canned cycle Multiple repetitive canned cycle
Series 20 <i>i</i>	OPERATOR'S MANUAL (For Manual Laths) (B-64194EN)	II.13.1 II.13.2	Canned cycle Multiple repetitive canned cycle

11.10 MIRROR IMAGE FOR DOUBLE TURRETS (T SERIES)

General

Mirror image can be applied to the X-axis with G code.

G68 : Start double turret mirror image
G69 : Mirror image cancel

When G68 is active, the coordinate system is shifted to the other turret, and the X-axis sign is reversed from the programmed command. To use this function, set the distance between the two turrets in a parameter (No. 1290).

Program example for double turrets.

X40.0 Z180.0 T0101 ; Position turret A at (1)
 G68 ; Shift the coordinate system by the distance A to B (120mm), and turn mirror image on.
 X80.0 Z120.0 T0202 ; Position turret B at (2)
 G69 ; Shift the coordinate system by the distance B to A, and cancel mirror image.
 X120.0 Z60.0 T0101 ; Position turret A at (3)

Parameter

- Distance between two turrets

1290	Distance between two turrets for mirror image
------	---

[Data type] Two-word

[Unit of data]	Increment system	IS-A	IS-B	IS-C	Unit
	Millimeter machine	0.01	0.001	0.0001	mm
	Inch input	0.001	0.0001	0.00001	inch

[Valid data range] 0 to 999999999

Set the distance between two turrets for mirror image.

Reference Item

Series 16i/18i/160i/180i/ 160is/180is	OPERATOR'S MANUAL (For Lathe) (B-63524EN)	II.13.6	Mirror image for double turrets
Series 21i/210i/210is	OPERATOR'S MANUAL (For Lathe) (B-63604EN)	II.13.5	Mirror image for double turrets

11.11 INDEX TABLE INDEXING FUNCTION (M SERIES)

General

Indexing the table on a machining center is accomplished by specifying a positioning angle.

Before and after indexing, the table is automatically unclamped or clamped.

Basic Procedure

The control axis that indexes the table can be named A, B or C. It will be referred to as "B" in the following discussion.

The positioning angle for the table is commanded by the numbers following "B" in the part program block. Both absolute and incremental commands are possible. The value for absolute "B" is based on the increment system.

(Example)	G00G90B100000;	Absolute command (Positioning angle 10 degrees)
	G00G91B20.0;	Incremental command (Move distance 20 degrees)

There are two variations of the procedure (type A and type B) to set the index table position. The difference is in the ON/OFF timing of the position control servo. The sequence of events timing charts and the difference between the variations are described below.

- (1) Assume Bbbbb is ordered by the command program.
- (2) The CNC turns the B axis unclamp signal BUCLP <F061#0> to "1".
(Type B -- When BUCLP is turned to "1", the position control servo for the B axis is turned ON.)
- (3) When the unclamp process is completed, the PMC sets the axis unclamp signal *BEUCL <G038#6> to "0".
- (4) The CNC then sets the B axis unclamp signal BUCLP to "0" indicating it received the *BEUCL signal.
- (5) When the PMC is notified that BUCLP has been set to "0", the PMC should set *BEUCL to "1".
In type B, B-axis unclamp signal BUCLP is set to "0", B-axis position control is made with servos active, B-axis is rotated, and the B axis is stopped at the specified position. B axis always moves at rapid traverse.
- (6) When the B axis stops at the specified position, the CNC sets the B-axis clamp signal BCLP <F061#1> to 1. In type A, signal BCLP is set to "1" and B-axis position control is made with servo off.
- (7) When BCLP is set to "1" on the PMC side, the B axis is clamped mechanically (with a clutch or shot pin, for example). When the clamp is completed, the B axis clamp completion signal *BECLP <G038#7> is set to "0".
- (8) When *BECLP is turned to "0", the CNC then sets BCLP to "0". (Type B -- When BCLP turns to "0", the B axis position control servo is turned off.)

(9) On the PMC side, when BCLP changes to “0”, *BECLP is set to “1”. This completes the sequence.

The time charts for these operations are shown in the figures below.

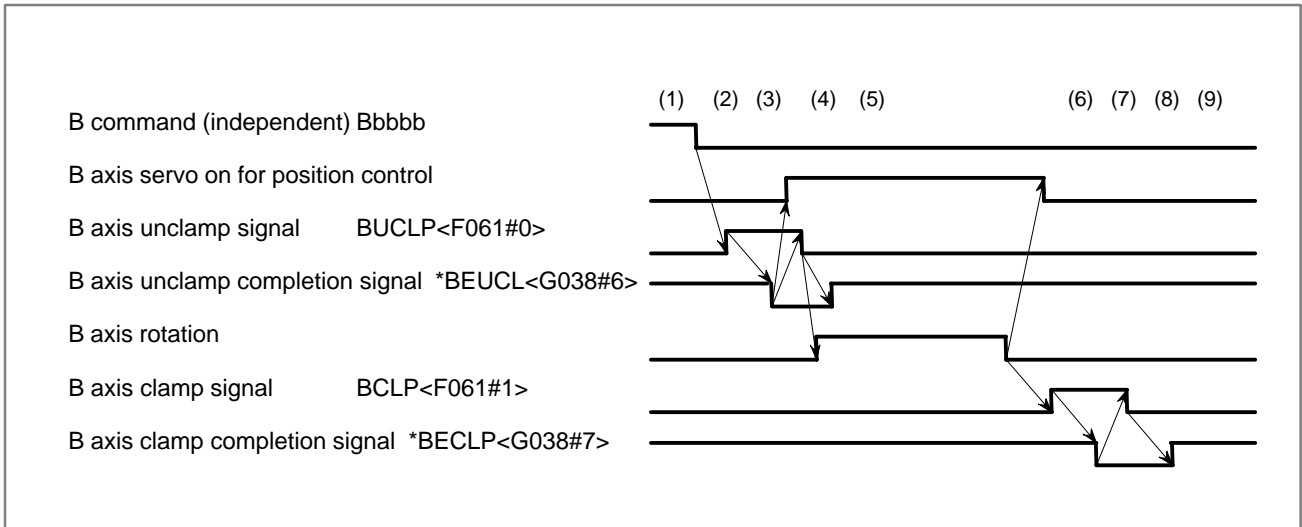

Fig. 11.11 (a) Time chart for positioning index table (type A)

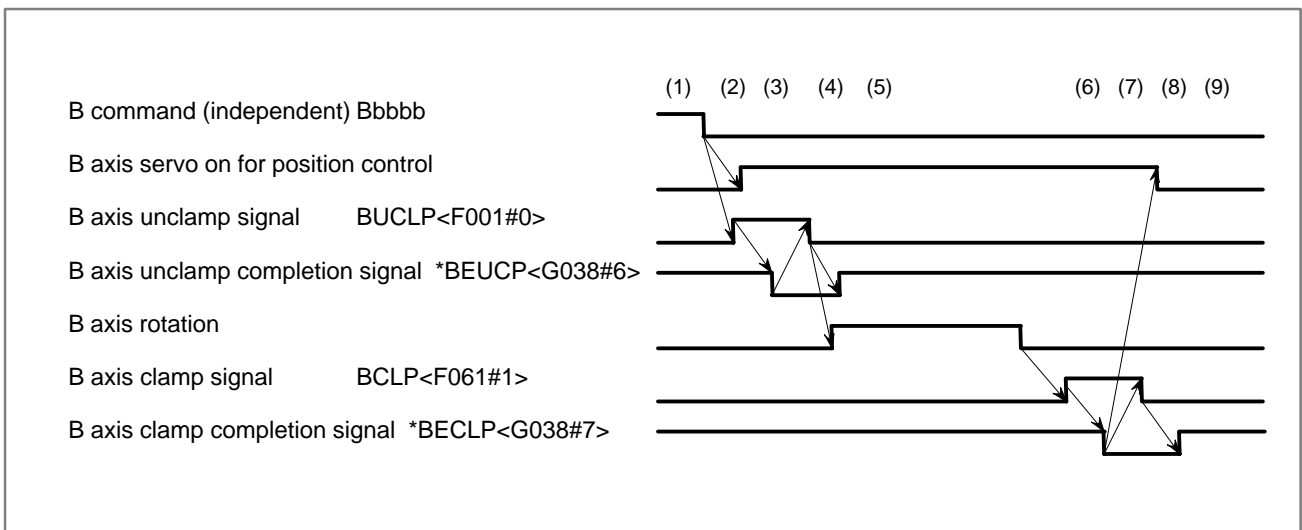

Fig. 11.11 (b) Time chart for positioning index table (type B)

The figure below shows the timing chart for type-A manual reference position return of the B axis.

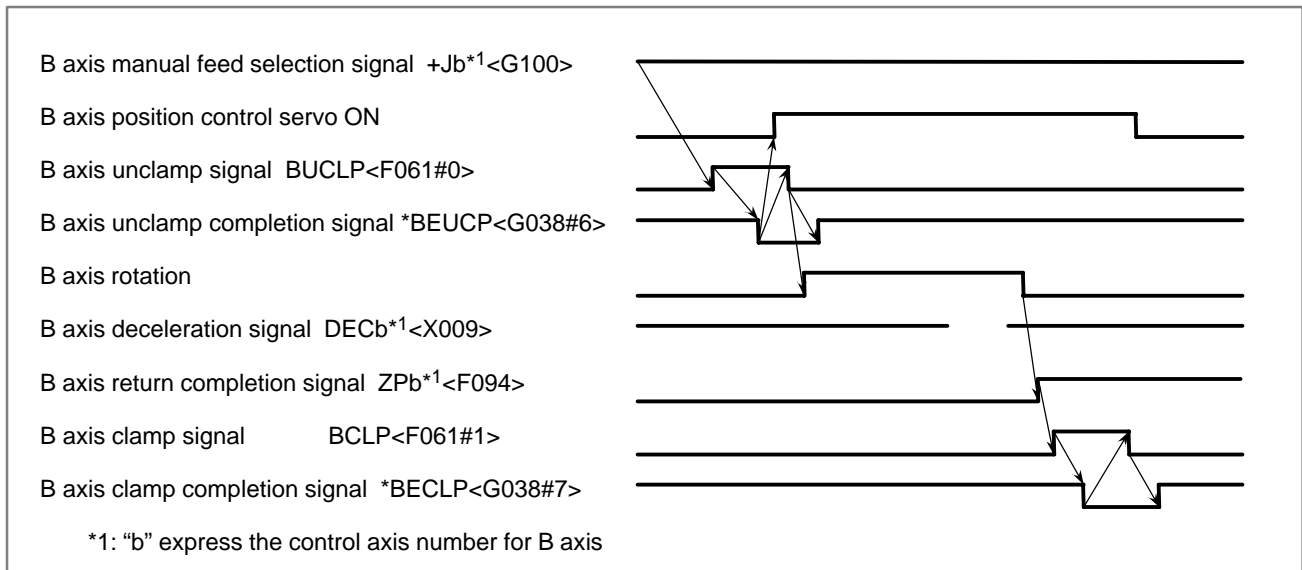

Fig. 11.11 (c) Manual reference position return of B axis (type A)

Type A and Type B

Type A differs from type B in the timing of the servo on/off signal. Type A is suitable for a system in which the B-axis is clamped with shot pins.

Type B is suitable for a system in which the B-axis is clamped with a clutch.

Minimum indexing angle

When the B-axis is clamped with shot pins, the mechanism can be indexed at only a limited number of positions. The minimum indexing angle can be specified in parameter No. 5512. If an angle is not a multiple of this minimum indexing angle, then alarm No. 135 is issued.

Direction of rotation

The direction of rotation can be set to one of the following.

- The direction with the shorter travel distance (INC, bit 3 of parameter No. 5500)
- Direction specified with a command
- The positive direction. Only when a particular M code is specified in the same block, the axis rotates in the negative direction (parameter No. 5511).

Absolute/incremental programming

Setting G90, bit 4 of parameter No. 5500, specifies absolute programming, and override the G90/G91 G-codes.

Signal

B axis clamp signal

BCLP<F061#1>

[Classification] Output signal

[Function] Instructs the PMC side to clamp the B axis mechanically with a clutch or shot pin.

[Output condition] The output condition and procedure are the same as those described in the basic procedure for positioning the index table.

B axis clamp completion signal

BECLP<G038#7>

[Classification] Input signal

[Function] Notifies the CNC of completion of the B axis clamp operation.

[Operation] The operation and procedure are the same as those described in the basic procedure for positioning the index table.

B axis unclamp signal

BUCLP<F061#0>

[Classification] Output signal

[Function] Instructs the PMC side to release the B axis from the mechanical clamp.

[Output condition] The output condition and procedure are the same as those described in the basic procedure for positioning the index table.

B axis unclamp completion signal

*BEUCP<G038#6>

[Classification] Input signal

[Function] Notifies the CNC of completion of the release of the B axis from the mechanical clamp.

[Operation] The operation and procedure are the same as those described in the basic procedure for positioning the index table.

Signal address

	#7	#6	#5	#4	#3	#2	#1	#0
G038	*BECLP	*BEUCP						
	#7	#6	#5	#4	#3	#2	#1	#0
F061							BCLP	BUCLP

Parameter

● **Setting linear or rotation axis**

	#7	#6	#5	#4	#3	#2	#1	#0
1006							ROSx	ROTx

[Data type] Bit axis

ROTx, ROSx Define linear or rotation axis

ROSx	ROTx	Description
0	0	Linear axis · Inch/metric conversion is done. · All coordinate values are linear axis type. (Not rounded in 0 to 360°) · Stored pitch error compensation is linear axis type (Refer to parameter No. 3624)
0	1	Rotation axis (A type) · Inch/metric conversion is not done. · Machine coordinate values are rounded in 0 to 360° Rounding of absolute coordinate values and relative coordinate values is decided by parameter No. 1008#0 and #2. · Stored pitch error compensation is of the rotation type. (Refer to parameter No. 3624) · Automatic reference position return (G28, G30) is done in the reference position return direction and the move amount does not exceed one rotation.
1	0	Setting is invalid (unused)
1	1	Rotation axis (B type) · Inch/metric conversion is not done. · Machine coordinate values is of linear axis type (i.e. not rounded in 0 to 360°). · Rounding of absolute coordinate values and relative coordinate values is decided by parameter No. 1008#0 and #2. · Stored pitch error compensation is of linear axis type (Refer to parameter No. 3624). · Cannot be used with the rotation axes roll over function and the index table indexing function (M series).

● **Setting for positioning the index table**

	#7	#6	#5	#4	#3	#2	#1	#0
5500	IDX	SIM		G90	INC	ABS	REL	DDP

[Data type] Bit

DDP Definition of index values

- 0 : Conventional method (Example IS-B: B1; = 0.001 deg)
- 1 : Calculator method (Example IS-B: B1; = 1.000 deg)

REL Relative position display of index table indexing axis

- 0 : Not rounded by 360 degrees
- 1 : Rounded by 360 degrees

ABS Displaying absolute coordinate value of index axis

- 0 : Not rounded by 360 degrees
The index axis rotates 720 degrees (two rotations) when G90 B720.0; is specified from the 0-degree position. It rotates in reverse direction 720 degrees (two rotations) when G90 B0.; is specified. The absolute coordinate value then becomes 0 degree.
- 1 : Rounded by 360 degrees
The index axis is positioned to 40 degrees when G90 B400.0; is specified from the 0-degree position. The index axis does not rotate by two or more turns when this parameter is set to 1. It also does not move when G90 B720.0; is specified from the 0-degree position.

INC Rotation in the G90 mode. This applies when negative direction M-code (parameter No. 5511) is not set

- 0 : Not set to the shorter distance around the circumference
- 1 : Move the shorter distance around the circumference (Set ABS, #2 of parameter No. 5500, to 1.)

G90 Index table indexing command

- 0 : An absolute/increment command according to the G90/G91 mode
- 1 : Always an absolute command

SIM When the same block includes a command for an index table indexing axis and a command for another controlled axis:

- 0 : A P/S alarm (No.136) is issued.
- 1 : The commands are executed. (In a block other than G00, G28, and G30, however, a P/S alarm (No.136) is issued.)

IDX Index table indexing sequence

- 0 : Type A
- 1 : Type B

● **Negative direction rotation command M code**

5511	Negative direction rotation command M code
------	--

[Data type] Byte

[Valid data range] 0 to 255

0 : No M code is defined to set the index table rotation to the negative direction. The rotation direction is specified using a command and parameter (INC, #3 of parameter No. 5500).

1 to 255:

Defines an M code to set the index table rotation to the negative direction. The rotation is set to the negative direction only when this M code is specified in the same block as an index table indexing command. If the M code is not specified in the same block, the rotation is always set to the positive direction.

NOTE
Set ABS (bit 2 of parameter No. 5500) to 1.

● **Unit of index table indexing angle**

5512	Unit of index table indexing angle
------	------------------------------------

[Data type] Two-word

[Unit of data]	Increment system	IS-A	IS-B	IS-C	Unit
	Metric input	0.01	0.001	0.0001	mm

[Valid data range] 0 to 360000

This parameter sets the unit of index table indexing angle. The commanded movement must be a multiple of the value entered in this parameter, Other wise, a P/S alarm occur.

NOTE
If zero is specified as the setting value, any command can be specified.

Alarm and message

Number	Message	Description
135	ILLEGAL ANGLE COMMAND	The commanded index positioning angle was not multiple of the value of the minimum angle. Modify the program.
136	ILLEGAL AXIS COMMAND	In index table indexing , another control axis was commanded with the index axis. Modify the program.

Caution**CAUTION**

- 1 The secondary auxiliary function can be used, but its address must be different from that of the indexing axis.
- 2 If the incremental command is used for indexing of the index table, the workpiece zero point offset value on the index table axis must always be 0. That is, the machine coordinate system must always agree with the workpiece coordinate system of the index table axis.
- 3 The dry run signal DRN has no affect during positioning of the B axis.
- 4 The machine lock signal MLK is functional during positioning of the B axis. When the B axis starts moving and the machine lock signal MLK turns to "1" during axis movement, however, the signal is disabled until axis movement stops.

Note**NOTE**

- 1 To specify a rotation axis as the index table indexing axis. (Set the ROTx bit (bit 0 of parameter No. 1006)="1".)
- 2 The servo off signal for the index table indexing axis is invalid.
- 3 Single direction positioning (G60) cannot be specified.
- 4 While the index table is being positioned, input signals that reset the CNC, such as *ESP (emergency stop), ERS (external reset), and RRW (reset & rewind), are functional. When reset is applied to the CNC, indexing stops. Further, if *SP (automatic operation stop signal) turns to "0", axis movement is stopped and the equipment enters the automatic operation stop state.
If a stop at an any position is not suitable for the machine, appropriate processing is required on the machine.
- 5 If a reset occurs while the system is awaiting the completion of clamping or unclamping, the clamp or unclamp signal is cleared. The CNC exits from the completion wait status.
- 6 Manual operation of jog feed, incremental feed and handle feed cannot be used with the indexing axis, but manual reference position return is possible. If reset is applied during the movement of the indexing axis, then manual reference position return should be performed.
- 7 No movement can be performed by automatic return from the reference position (G29), return to the second reference position (G30), or selection of the machine coordinate system (G53).
- 8 Only the fourth axis can be used as the index table indexing axis.

Reference Item

Series 16 <i>i</i> /18 <i>i</i> /160 <i>i</i> /180 <i>i</i> / 160 <i>s</i> /180 <i>s</i>	OPERATOR'S MANUAL (For Machining Center) (B-63534EN)	II.13.11	Index table indexing function
Series 21 <i>i</i> /210 <i>i</i> /210 <i>s</i>	OPERATOR'S MANUAL (For Machining Center) (B-63614EN)	II.13.5	Index table indexing function

11.12 SCALING (M SERIES)

General

- **Scaling up or down along all axes at the same rate of magnification**

A programmed figure can be magnified or reduced (scaling). The dimensions specified with X_, Y_, and Z_ can each be magnified or reduced with the same or different rates of magnification. The magnification rate can be specified in the program or by a parameter.

Least input increment of scaling magnification is: 0.001 or 0.00001 and is set by parameter SCR (No. 5400#07).

The scaled axis is selected by parameter SCLx (bit 0 of parameter No. 5401).

The value in the scaling magnification parameter (No. 5411) is used when not defined in the program.

If X,Y,Z are omitted, the tool position where the G51 command was specified serves as the scaling center.

SCALING UP OR DOWN ALONG ALL AXES AT THE SAME RATE OF MAGNIFICATION		
Format	Meaning of command	
G51 X_Y_Z_P_ ; Scaling start	X_Y_Z_ : Absolute command for center coordinate value of scaling P_ : Scaling magnification	
⋮ ⋮ ⋮		} Scaling is effective. (Scaling mode)
G50 ; Scaling cancel		

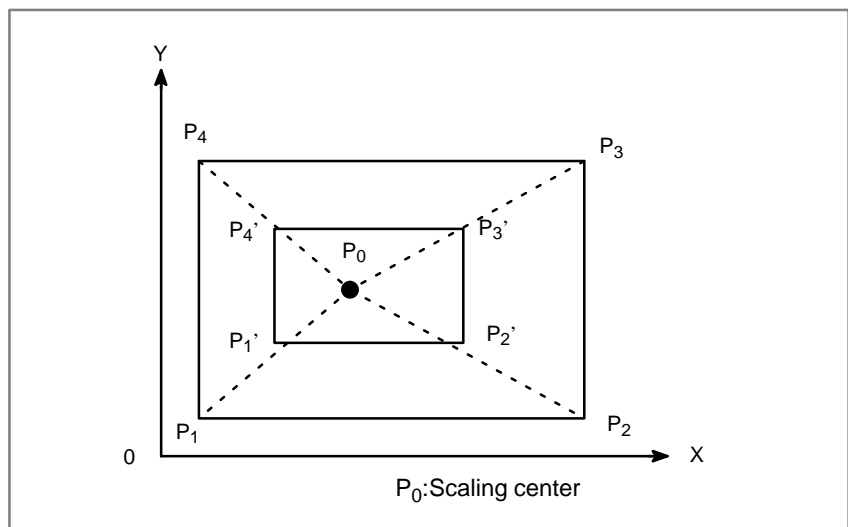

Fig. 11.12 (a) Scaling (P₁ P₂ P₃ P₄→P₁'P₂'P₃'P₄')

● **Scaling of each axis, programmable mirror image (negative magnification)**

Each axis can be scaled by different magnifications. Also when a negative magnification is specified, a mirror image is applied. First of all, set a parameter XSC (No. 5400#6) which validates each axis scaling (mirror image).

Then, set parameter SCLx (No. 5401#0) to enable scaling along each axis. Least input increment of scaling magnification of each axis (I, J, K) is 0.001 or 0.00001(set parameter SCR (No. 5400#7)).

Magnification is set in parameter 5421 within the range ± 0.00001 to ± 9.99999 or ± 0.001 to ± 9.999 .

If a negative value is set, mirror image is applied.

If magnification I, J or K is not commanded, a magnification value set to parameter (No. 5421) is used. This value must be greater than 0.

SCALING ALONG EACH AXES AT A DIFFERENT RATE OF MAGNIFICATION (MIRROR IMAGE)	
Format	Meaning of command
G51 X_Y_Z I_J_K_;	X_Y_Z_ : Absolute command for center coordinate value of scaling I_J_K_ : Scaling magnification for X axis, Y axis and Z axis respectively
: : :	
G50	Scaling cancel

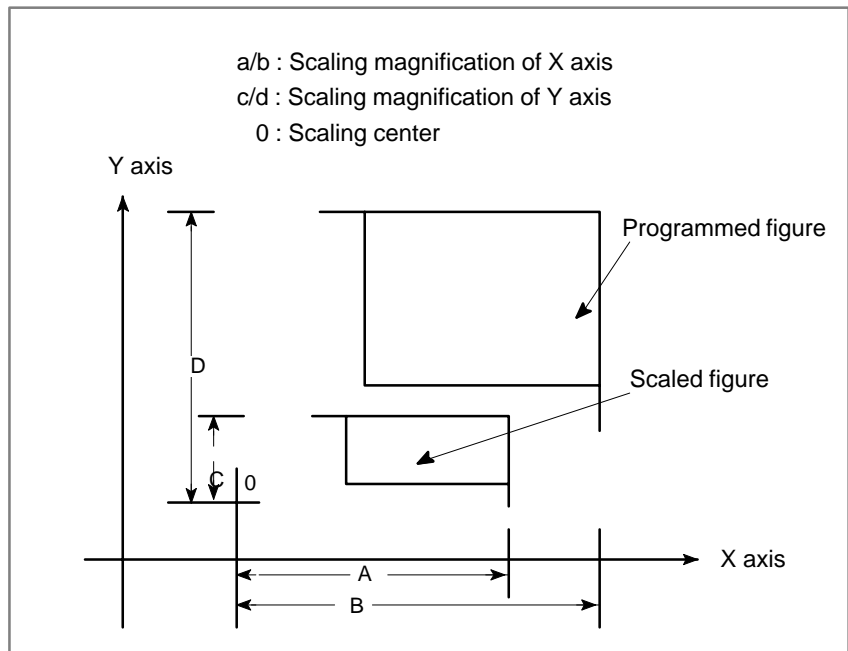

Fig. 11.12 (b) Scaling of each axis

Parameter

- **Setting valid/invalid and magnification of scaling**

	#7	#6	#5	#4	#3	#2	#1	#0
5400	SCR	XSC						

[Data type] Bit

XSC Axis scaling and programmable mirror image

0 : Not active (The scaling magnification is specified by P.)

1 : Active

SCR Scaling magnification unit

0 : 0.00001 times (1/100,000)

1 : 0.001 times

- **Valid/invalid setting to each axis scaling**

	#7	#6	#5	#4	#3	#2	#1	#0
5401								SCLx

[Data type] Bit axis

SCLx Scaling for every axis

0 : Not active

1 : Active

- **Default scaling magnification value**

5411	Default scaling magnification value
------	-------------------------------------

Setting entry is acceptable.

[Data type] Two-word

[Unit of data] 0.001 or 0.00001 times (Selected using SCR, #7 of parameter No. 5400)

[Valid data range] 1 to 999999

This parameter sets the scaling magnification. This setting value is used when a scaling magnification (P) is not specified in the program.

NOTE

Parameter No. 5421 becomes valid when scaling for every axis is valid. (XSC, #6 of parameter No. 5400 is "1".)

- **Scaling magnification for every axis**

5421	Scaling magnification for every axis
------	--------------------------------------

[Data type] Two-word axis

[Unit of data] 0.001 or 0.00001 times (Selected using SCR, #7 of parameter No. 5400)

[Valid data range] - 999999 ~ - 1, 1 ~ 999999

This parameter sets the scaling magnification for every axis.

Alarm and message

Number	Message	Description
141	CAN NOT COMMAND G51 IN CRC	G51 (Scaling ON) is commanded in the tool offset mode. Modify the program.
142	ILLEGAL SCALE RATE	Scaling magnification is commanded in other than 1 - 999999. Correct the scaling magnification setting (G51 P _p , or parameter 5411 or 5421).
143	SCALED MOTION DATA OVERFLOW	The scaling results, move distance, coordinate value and circular radius exceed the maximum command value. Correct the program or scaling magnification.

Reference item

Series 16i/18i/160i/180i/160is/180is	OPERATOR'S MANUAL (For Machining Center) (B-63534EN)	II.14.9	Scaling (G50, G51)
Series 21i/210i/210is	OPERATOR'S MANUAL (For Machining Center) (B-63614EN)	II.14.7	Scaling (G50, G51)
Series 20i	OPERATOR'S MANUAL (For Manual Milling Machine) (B-64204EN)	II.14.5	Scaling (G50, G51)

11.13 COORDINATE SYSTEM ROTATION

General

A programmed shape can be rotated. By using this function it is possible to modify a program using a rotation command. This is useful when a workpiece has been placed with some angle rotated from the programmed position on the machine. This is also useful when machining the same pattern.

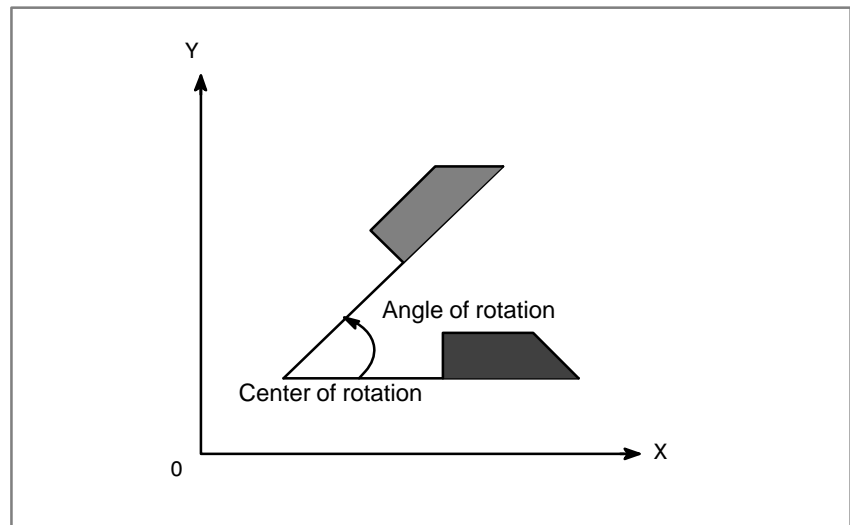

Fig. 11.13 (a) Coordinate system rotation

FORMAT	
$\left. \begin{matrix} \{ \text{G17} \\ \text{G18} \\ \text{G19} \} \\ \vdots \\ \text{G69 (G69.1)} \end{matrix} \right\}$	G68 (G68.1) $\alpha_ \beta_ R_ ;$ Start rotation of a coordinate system.
	$\left. \begin{matrix} \text{Coordinate system rotation mode} \\ \text{(The coordinate system is rotated.)} \end{matrix} \right\}$
	Coordinate system rotation cancel command
Note:G68/G69 for M series, G68.1/G69.1 for T series.	
MEANING OF COMMAND	
G17 (G18 or G19) : Select the plane that contains the figure to be rotated. $\alpha_ \beta_$ R_	Absolute command for two of the $x_ , y_ ,$ and $Z_$ axes that correspond to the current plane selected. The command specifies the coordinates of the center of rotation. A positive angular displacement indicates counter clockwise rotation. Parameter 5400#0 selects whether the specified angular displacement is always considered an absolute value or is considered an absolute or incremental value depending on the specified G code (G90 or G91).
Least input increment : 0.001 deg Valid data range : -360.000 to 360.000	

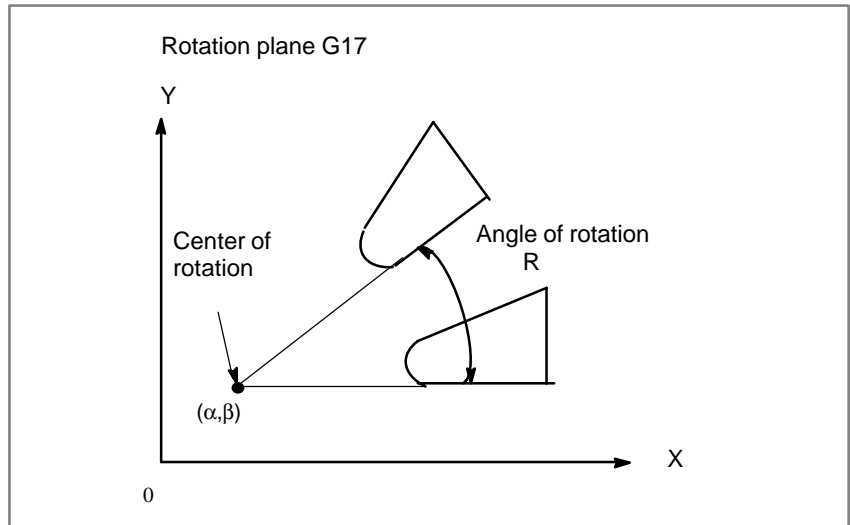
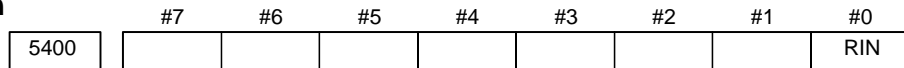

Fig. 11.13 (b) Coordinate system rotation

Parameter

- **Angle specification method of coordinate system rotation**



[Data type] Bit

RIN Coordinate rotation angle command (R)

0 : Specified by an absolute method

1 : Specified by G90 or G91

- **Angular displacement used when no angular displacement is specified for coordinate system rotation**

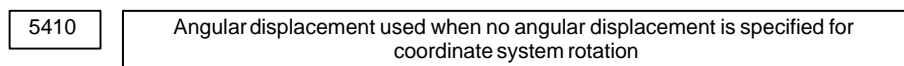

[Data type] Two-word

[Unit of data] 0.001 degrees

[Valid data range] -360000 to 360000

This parameter sets the angular displacement for coordinate system rotation. When the angular displacement is not specified with address R in the G68 block, this parameter value is used as the angular displacement.

Alarm and message

Number	Message	Description
144	ILLEGAL PLANE SE- LECTED	The coordinate rotation plane and arc or cutter compensation C plane must be the same. Modify the program.
5302	ILLEGAL COMMAND IN G68 MODE	A command to set the coordinate system is specified in the coordinate system rotation mode.

Reference item

Series 16 <i>i</i> /18 <i>i</i> /160 <i>i</i> /180 <i>i</i> / 160 <i>s</i> /180 <i>s</i>	OPERATOR'S MANUAL (For Machining Center) (B-63534EN)	II.14.10	Coordinate system rotation (G68, G69)
	OPERATOR'S MANUAL (For Lathe) (B-63524EN)	II.14.7	Coordinate system rotation (G68.1, G69.1)
Series 21 <i>i</i> /210 <i>i</i> /210 <i>s</i>	OPERATOR'S MANUAL (For Machining Center) (B-63614EN)	II.14.8	Coordinate system rotation (G68, G69)
Series 20 <i>i</i>	OPERATOR'S MANUAL (For Manual Milling Machine) (B-64204EN)	II.14.6	Coordinate system rotation (G68, G69)

11.14 THREE-DIMENSIONAL COORDINATE CONVERSION

General

The coordinate system can be rotated about an axis by specifying the center of rotation, direction of the axis of rotation, and angular displacement. This coordinate conversion function is quite useful for three-dimensional machining on a diesinking machine. By applying this conversion to a program generated for machining on the XY plane, identical machining can be executed on the desired plane.

When rigid tapping is commanded in three-dimensional coordinate conversion mode, tapping can be done at the angle specified by a three-dimensional coordinate conversion command. (This is called three-dimensional rigid tapping.)

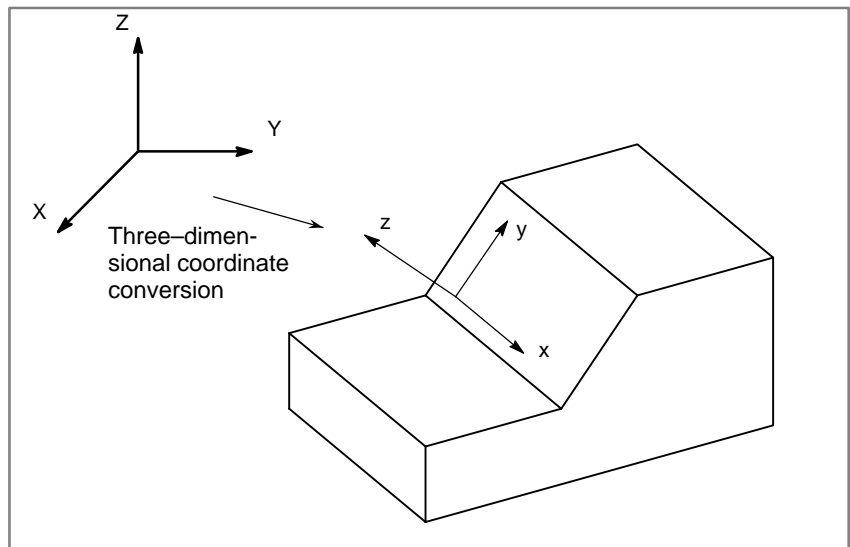

Parameter

● Setting relative position and absolute position

	#7	#6	#5	#4	#3	#2	#1	#0
3104	DAC	DAL	DRC	DRL				

[Data type] Bit

DRL Relative position

0 : The actual position displayed includes tool length offset value (M series)/tool offset value (T series).

1 : The programmed position displayed does not include tool length offset value (M series)/tool offset value (T series).

DRC Relative position

0 : The actual position displayed includes cutter compensation value (M series)/tool nose radius compensation value (T series).

1 : The programmed position displayed does not include cutter compensation value (M series)/tool nose radius compensation value (T series).

DAL Absolute position

0 : The actual position displayed includes tool length offset value (M series)/tool offset value (T series).

1 : The programmed position displayed does not include tool length offset value (M series)/tool offset value (T series).

DAC Absolute position

0 : The actual position displayed includes cutter compensation value (M series)/tool nose radius compensation value (T series).

1 : The programmed position displayed does not include cutter compensation value (M series)/tool nose radius compensation value (T series).

To display absolute position with three-dimensional coordinate conversion, the DRL, DRC, DAL, and DAC bits must be set to 1.

● Setting absolute coordinates in the three-dimensional coordinate conversion mode

	#7	#6	#5	#4	#3	#2	#1	#0
3106		DAK						

[Data type] Bit

DAK When absolute coordinates are displayed in the three-dimensional coordinate conversion mode:

0 : Coordinates in the program coordinate system are displayed.

1 : Coordinates in the workpiece coordinate system are displayed.

This parameter is significant only in three-dimensional coordinate conversion mode.

Alarm and message

Number	Message	Description
047	ILLEGAL AXIS SELECT	For startup of three-dimensional tool compensation or three-dimensional coordinate conversion, two or more axes were specified in the same direction (basic and parallel axes.)
048	BASIC 3 AXIS NOT FOUND	For startup of three-dimensional tool compensation or three-dimensional coordinate conversion, the three basic axes used when X_p , Y_p , and Z_p are omitted were not specified in parameter No. 1022.
5043	TOO MANY G68 NESTING (M series)	G68, three-dimensional coordinate conversion, was invoked three times or more.
	TOO MANY G68.1 NESTING (T series)	G68.1, three-dimensional coordinate conversion, was invoked three times or more.
5044	G68 FORMAT ERROR (M series)	A format error occurred in a G68 block. The alarm is issued when any of the following takes place. (1) In a block including G68, any of I, J, and K is not specified (the option for coordinate rotation is not provided). (2) In a block including G68, all of I, J, and K is 0. (3) In a block including G68, R is not specified.
	G68.1 FORMAT ERROR (T series)	A format error occurred in a G68.1 block. The alarm is issued when any of the following takes place. (1) In a block including G68.1, any of I, J, and K is not specified (the option for coordinate rotation is not provided). (2) In a block including G68.1, all of I, J, and K is 0. (3) In a block including G68.1, R is not specified.
5219	CAN NOT RETURN	Manual intervention or return is not allowed during three-dimensional coordinate conversion.

Reference item

Series 16i/18i/160i/180i/ 160is/180is	OPERATOR'S MANUAL (For Machining Center) (B-63534EN)	II.13.10	Three-dimensional coordinate conversion (G68, G69)
	OPERATOR'S MANUAL (For Lathe) (B-63524EN)	II.13.9	Three-dimensional coordinate conversion (G68.1, G69.1)

11.15 RETRACE (M SERIES)

General

A tool can retrace the tool path along which the tool has moved. In addition, a tool can move forward again along the path that the tool has retraced. The tool can then resume machining according to the program when it returns to the position where it started retrace.

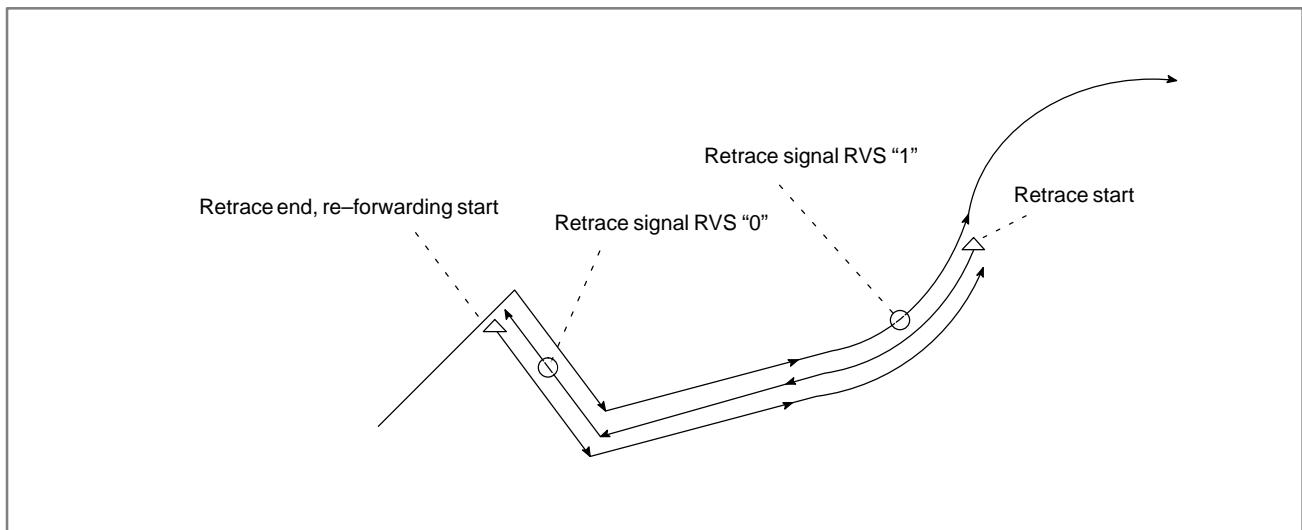

By using the PMC input signal RVS, retrace can be performed. Retrace is performed when the retrace signal RVS turns to "1". Re-forward operation is performed when the retrace signal turns to "0". In retrace, a tool can retrace a limited number of blocks that have been executed in the automatic operation mode (memory command, tape command, manual data input). For detailed information, refer to the operator's manual. A return feedrate can be specified by setting parameter No. 1414.

Signal

Retrace signal RVS

<G007#0>

[Classification] Input signal

[Function] Directs the control unit to retrace the tool along the path which the tool was moved in automatic operation (memory command, tape command, manual data input).

[Operation] When RVS turns to “1”, the tool retraces the tool path along which it was moved. The tool does not start retrace immediately after this signal turns to “1”; the tool starts retrace after the current block. When RVS turns to “0” while retrace is in progress, the tool switches from retracing to tracing forward. In this case also, the tool does not start re-forward to resume machining immediately after this signal turns to “0” retrace; the tool starts re-forward after retracing all commands of the block currently subject to retrace.

The movement of a tool can be immediately switched from forward to retrace or from retrace to re-forward. By first turning the feed hold signal *SP to “0” to stop automatic operation. Then, change the state of RVS after the automatic operation start in-progress signal STL turns to “0” and the automatic operation stop state is set. And the feed hold lamp SPL turns to “1”. Next, the feed hold signal *SP and the automatic operation start signal ST turn from “1” to “0”. Then, the tool can switch its movement to retrace or re-forward during execution of a block.

Retrace-in-progress signal RVSL

<F082#2>

[Classification] Output signal

[Function] Notifies the PMC that retrace is in progress.

[Output condition] This signal turns to “1” when:

- Tool is in retrace with the retrace signal RVS turned to “1”.

This signal turns to “0”

- The tool is in forward or re-forward with the retrace signal RVS turned to “0”.
- The tool is at stop because there is no block for retracing.

When the tool is in retrace, the M functions, S functions, T functions, and second auxiliary functions are executed in the same way as when the tool is moving forward. During retrace, this signal can be used on the PMC, to prevent these functions from being executed.

When an M function, S function, T function, or second auxiliary function is specified in a block containing a move command, the positions where the code signals and strobe signal are output differ, depending on whether the tool is in forward (or re-forward) or retrace.

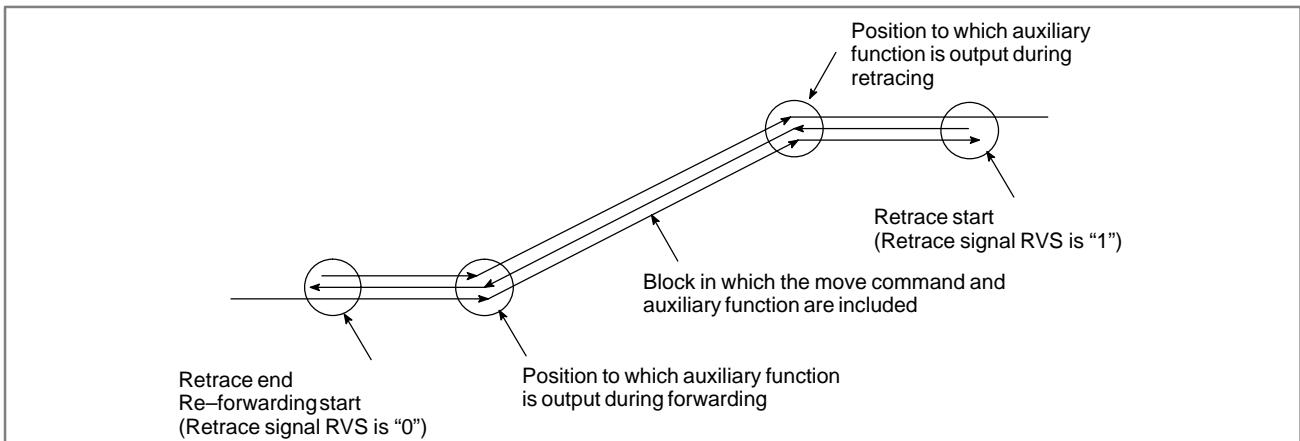

Signal address

	#7	#6	#5	#4	#3	#2	#1	#0
G007								RVS
	#7	#6	#5	#4	#3	#2	#1	#0
F082						RVSL		

Parameter

1414	Feedrate for retrace
------	----------------------

[Data type] Two-word

This parameter sets the feedrate for retrace.

(1) For rapid traverse

[Unit of data] [Valid data range]	Increment system	Unit of data	Valid data range	
			IS-A, IS-B	IS-C
	Millimeter machine	1 mm/min	6 to 240000	6 to 100000
	Inch machine	0.1 inch/min	6 to 96000	6 to 48000
	Rotation axis	1 deg/min	6 to 240000	6 to 100000

NOTE

When 0 is set in this parameter, the rapid traverse rate set in parameter No. 1420 is used for retrace.

(2) For cutting feed

When 0 is specified in this parameter, the programmed feedrate (F command) is used for retrace.

Alarm and message

While a tool is in retrace, the retrace-in-progress signal RVSL is sent, and the character string RVRS blinks on the CRT screen. When a tool is in re-forward, the character string RTRY blinks to signal that the tool is currently in re-forward. RTRY continues until the tool returns to the block where retrace was started. When there are no more retraceable blocks, the character string RVED blinks to signal that no further retrace can take place.

Warning

WARNING

Positioning (G00)

If non-linear-interpolation positioning is executed (the LRP bit (bit 1 of parameter No. 1401) is set to 0), the retrace tool path will not agree with the forward tool path. The re-forward tool path agrees with the forward tool path.

If the linear interpolation positioning is executed (the LRP bit (bit 1 of parameter No. 1401) is set to 1), the retrace tool path agrees with the forward tool path.

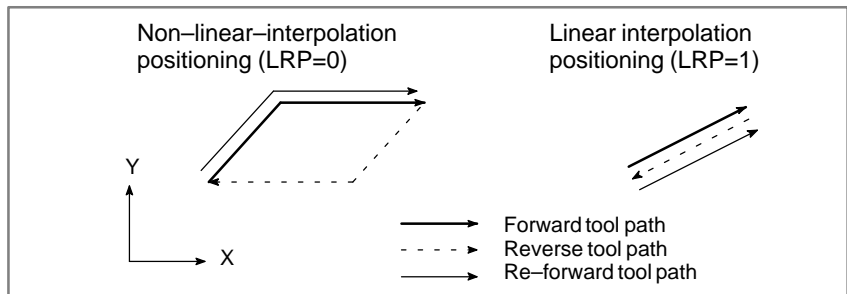

Reference item

Series 16i/18i/160i/180i/ 160is/180is	OPERATOR'S MANUAL (For Machining Center) (B-63534EN)	III.4.11	Retrace function
---	--	----------	------------------

11.16 MACRO COMPILER/ EXECUTER

General

The macro executor function converts custom macros created by machine tool builders to executable programs, registers them in the flash ROM module, and executes them to solve problems as described below.

NC programs are divided into two types: Programs that are hardly modified after created (programs created using custom macros) and programs that differ depending on the workpiece (machining programs). Since different types of programs are processed in the same way, a custom macro may be destroyed due to a battery failure or operator error.

Features

- (1) Since the program is stored in executable form program, the execution speed is high. Machine time is then reduced, and precision is improved.
- (2) Since the program is stored in FLASH ROM, there is no lost of data of battery failure or corruption. Reliability is improved.
- (3) The stored program is not displayed on a program screen.
- (4) The custom macro is stored in FLASH ROM.
- (5) The user can call the macro without knowing the stored program. A custom macro can be created and executed in the program edit memory.
- (6) An original screen can be created by using the graphic display or by selecting screens by the soft key. The machine tool builder can extend the control function by using such functions as machine program creation and edit control, reader/punch interface control, and PMC data read/write functions.

Note

NOTE

- 1 When the macro executor is active, the order-made macro cannot be specified.
- 2 The macro executor requires the graphic display option, to display graphics.

Reference item

Macro compiler/executor programming manual (B-61803E-1)

11.17 SMALL HOLE PECK DRILLING CYCLE (M SERIES)

General

In peck drilling, the tool enters and retracts from hole based on an overload torque detection signal (skip signal) until the designed hole depth is reached. The spindle speed and cutting feedrate are changed on each entry of the hole.

The cycle is realized by:

- * X- and Y-axis positioning
- * Positioning at point R along the Z-axis
- * Cutting along the Z-axis (first time, depth of cut Q, incremental)

Repeated until point Z is reached

- Retracting (bottom of hole → minimum clearance Δ , incremental)
- Retracting (→ to point R, absolute)
- Forwarding (point R → to point with hole bottom + clearance Δ , absolute)
- Cutting (second and subsequent times, cut of depth $Q + \Delta$, incremental)
- * Dwell
- * Return to point R along the Z-axis (or initial point) = end of cycle

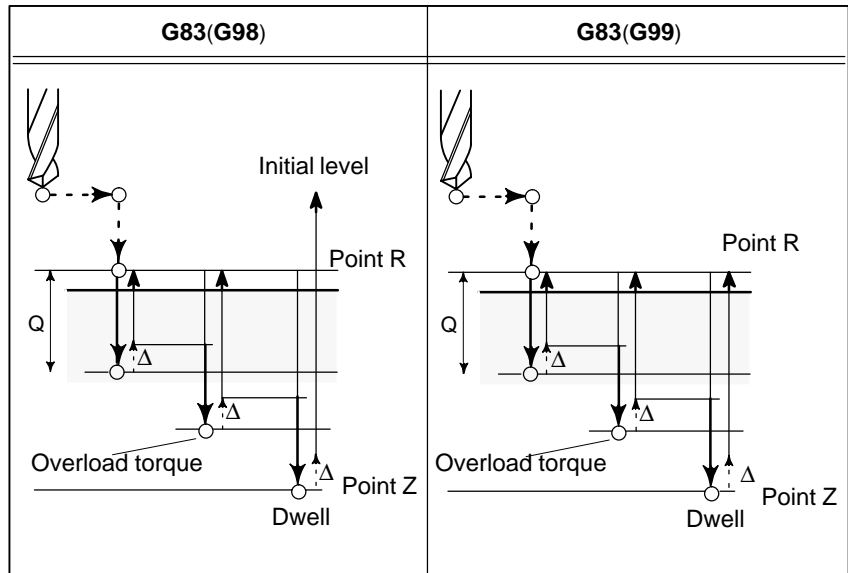

Change of cutting conditions

The cutting conditions are changed at each pecking operation (forwarding → cutting → retracting) during one G83 cycle. Bits 1 and 2 of parameter No. 5160 affects the cutting conditions.

● **Changing of cutting feedrate**

The cutting feedrate programmed with the F word is changed during the second and subsequent cutting operations. Parameter Nos. 5166 and 5167 specify the ratio of change for the case in which a skip signal was received during the previous cutting operation and the case in which no skip signal was received during the previous cutting operation, respectively.

$$\text{Cutting feed rate} = F \times \alpha$$

(First time) $\alpha = 1.0$

(Second and subsequent times) $\alpha = \alpha \times \beta \div 100$
(where β is the ratio of change for the first time)

Skip during the previous cutting: $\beta = b1\%$ (parameter No. 5166)

No skip during the previous cutting: $\beta = b2\%$ (parameter No. 5167)

The feedrate is not changed when the ratio α becomes less than the ratio specified in parameter No. 5168. The upper limit to the newly specified cutting feedrate is the maximum cutting feedrate.

● **Changing of spindle speed**

The spindle speed programmed with the S word is changed during the second and subsequent cutting operations. Parameter Nos. 5164 and 5165 specify the ratio of change in which a skip signal was received during the previous cutting operation and in which no skip signal was received during the previous cutting operation.

$$\text{Spindle speed} = S \times \gamma$$

(First time) $\gamma = 1.0$

(Second and subsequent times) $\gamma = \gamma \times \delta \div 100$
(where δ is the ratio of change for the first time)

Skip during the previous cutting: $\delta = d1\%$ (parameter No. 5164)

No skip during the previous cutting: $\delta = d2\%$ (parameter No. 5165)

If the spindle speed is set at the lower limit, then it is not changed. The upper limit to the newly specified spindle speed is the maximum S analog data.

Signal

Overload torque signal SKIP<X004#7>

[Classification] Input signal

[Function] Retracts a tool if an overload torque occurs.

[Operation] When this signal becomes "1", the control unit operates as follows:

- Retracts the tool, and changes the spindle speed and cutting feedrate, then continue machining.
- This signal is valid, when the drill axis is between points R and Z and is moving forward or cutting.

NOTE
This signal is used also as a skip signal. (See Section 14.3.)

Small-diameter peck drilling in progress signal PECK2<F066#5>

[Classification] Output signal

[Function] Indicates whether small-diameter peck drilling is in progress.

[Output condition] This signal becomes “1” under the following conditions.

- When the tool returns to R point/initial level, after entering the hole.
- The signal does not become “1” during positioning at the hole position.

Signal address

	#7	#6	#5	#4	#3	#2	#1	#0
X004	SKIP							
	#7	#6	#5	#4	#3	#2	#1	#0
F066			PECK2					

Parameter

	#7	#6	#5	#4	#3	#2	#1	#0
5160						NOL	OLS	

[Data type] Bit

OLS When an overload torque signal is received in a peck drilling cycle, the feed and spindle speed are

- 0 : Not changed.
- 1 : Changed.

NOL When the the depth of cut is reached, the feed and spindle speed are:

- 0 : Not changed.
- 1 : Changed.

5163	M code specifying the peck drilling cycle mode
------	--

[Data type] Two-word

[Valid data range] 1 to 99999999

This parameter defines the M-code for the peck drilling cycle.

5164

Percentage of the spindle speed to be changed when the tool is retracted after an overload torque signal is received

[Data type] Byte

[Unit of data] %

[Valid data range] 0 to 255

This parameter sets the percentage of the spindle speed change caused by the overload torque signal when the tool is retracted during a peck drilling cycle.

$$S2 = S1 \times d1 \div 100$$

S1: Spindle speed to be changed

S2: Spindle speed changed

d1 is set as a percentage.

5165

Percentage of the spindle speed to be changed when the tool is retracted without an overload torque signal received

[Data type] Byte

[Unit of data] %

[Valid data range] 0 to 255

This parameter sets the percentage of the spindle speed change during a peck drilling cycle.

$$S2 = S1 \times d2 \div 100$$

S1: Spindle speed to be changed

S2: Spindle speed changed

d2 is set as a percentage.

5166

Percentage of cutting feedrate to be changed when the tool is retracted after an overload torque signal is received

[Data type] Byte

[Unit of data] %

[Valid data range] 0 to 255

This parameter sets the percentage of the cutting feedrate change caused by the overload torque signal during a peck drilling cycle.

$$F2 = F1 \times b1 \div 100$$

F1: Cutting feedrate to be changed

F2: Changed cutting feedrate

b1 is set as a percentage.

5167	Percentage of the cutting feedrate to be changed when the tool is retracted without an overload torque signal received
------	--

[Data type] Byte

[Unit of data] %

[Valid data range] 0 to 255

This parameter sets the percentage of the cutting feedrate change during a peck drilling cycle.

$$F2 = F1 \times b2 \div 100$$

F1: Cutting feedrate to be changed

F2: Changed cutting feedrate

b2 is set as a percentage.

5168	Lower limit of the percentage of the cutting feedrate in a peck drilling cycle of a small diameter
------	--

[Data type] Byte

[Unit of data] %

[Valid data range] 0 to 255

This parameter sets the lower limit of the percentage of feedrate change for in a peck drilling cycle.

$$FL = F \times b3 \div 100$$

F: Specified cutting feedrate

FL: Changed cutting feedrate

Set b3 as a percentage.

5170	Macro variable where the total number of retractions is recorded
------	--

[Data type] Word

[Valid data range] 100 to 149

This parameter identifies the macro variable where the total number of times the tool is retracted is recorded. The macro variables cannot be variables 500 to 599.

5171	Macro variable to which the total number of retractions due to an overload signal is recorded
------	---

[Data type] Word

[Valid data range] 100 to 149

This parameter identifies the custom macro variable where the number of times the tool is retracted after the overload signal is recorded. The macro variable cannot be variables 500 to 599.

5172	Speed of retraction to point R when no I address is defined
------	---

[Data type] Word

[Unit of data] mm/min

[Valid data range] 0 to 4000

This parameter sets the speed of retraction to point R when no I address is defined.

5173	Speed advancing to the bottom of a hole when no I address is defined
------	--

[Data type] Word

[Unit of data] mm/min

[Valid data range] 0 to 4000

This parameter sets the speed for advancing to the bottom of a previously machined hole when no address I is defined.

5174	Clearance in a peck drilling cycle
------	------------------------------------

[Data type] Word

[Unit of data]	Increment system	IS-A	IS-B	IS-C	Unit
	Linear axis (millimeter input)	0.01	0.001	0.0001	mm
	Linear axis (inch input)	0.001	0.0001	0.00001	inch

[Valid data range] 0 to 32767

This parameter sets the clearance in a peck drilling cycle.

Alarm and message

• Diagnostic display

520	Total number of retract operations during cutting since G83 was issued
-----	--

521	Total number of retract operations due to reception of the overload torque signal since G83 was issued
-----	--

The indications of Nos. 520 and 521 are cleared by G80.

522	Coordinates at which the drill axis started retracting (least input command)
-----	--

523	Difference between the previous and current coordinates at which the drill axis started retracting (least input increment: previous – current)
-----	--

Warning**WARNING**

Forwarding or retracting is not performed by rapid traverse positioning. Instead, it is performed with the same interpolation as for cutting feed. This means exponential acceleration/deceleration is performed. However, the tool life management function does not count the tool life during forwarding or retracting.

Reference item

Series 16i/18i/160i/180i/ 160is/180is	OPERATOR'S MANUAL (For Machining Center) (B-63534EN)	II. 13.1.7	Small hole peck drilling cycle
Series 21i/210i/210is	OPERATOR'S MANUAL (For Machining Center) (B-63614EN)	II. 13.1.7	Small hole peck drilling cycle

11.18 HIGH-SPEED CYCLE MACHINING RETRACTING

General

Retract can occur during high-speed machining by setting the high-speed cycle machining retract signal HSRT to 1. Additionally, a retract path and speed must be defined for each axis.

Retracting

To use retracting during high-speed cycle machining, it is necessary to preset retract direction and speed for each axis using parameter No. 7514 and retract distance using parameter No. 7515. If the high-speed cycle machining retract signal HSRT becomes 1, this parameter-specified retract operation is performed. This operation enables the tool to escape while protecting the workpiece and tool from damage.

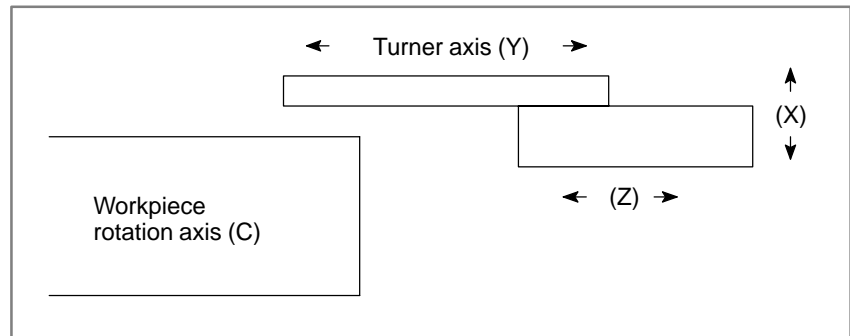

Fig. 11.18 Retracting performed on lead machine

Assuming retract direction and speed (fx) is set for the X-axis, turning on the retract signal enables the workpiece to retract along the X-axis simultaneously. In addition, if retract direction and speed for the Z-axis is set, a simultaneous operation like an X-Z escape operation can also be performed.

Retracting begins when the retract signal HSRT <G065#3> becomes 1. It ends when a distance specified in parameter No. 7515 expires, or when the current cycle is completed. In this case, the cycle connection information and the repetition cycle count are ignored, and the retract operation ends with the current one cycle. Therefore, the actual distance used for retracting can range from 1 to the distance specified in parameter No. 7515. If no retract cycle is defined, the CNC causes automatic operation to pause after retracting ends. If a retract cycle is defined, the CNC enters a retract cycle state.

When retracting begins, the retracting signal HSRA <F062#2> becomes 1. Resetting the retract signal HSRT to 0 does not stop the retract operation.

[Example]

- (1) Parameter No. 7515 setting < remaining distance for the current cycle
 A number of pulses for retracting based on the parameter-specified distance are superimposed on a usual operation. When the operation ends, the CNC shifts to an automatic operation pause or retract cycle execution.

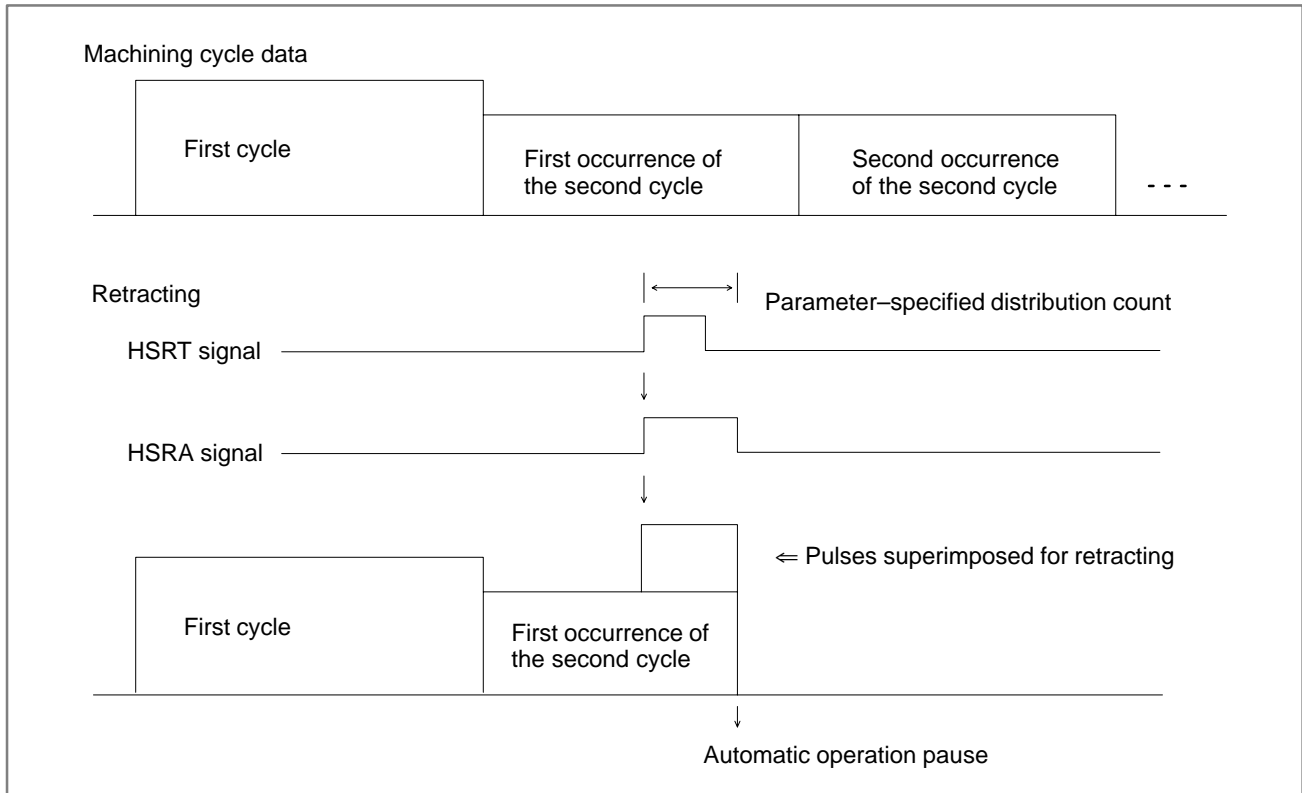

If the parameter No. 7515 setting is 0, the distance is assumed to be infinite, allowing retracting to continue until the current cycle ends.

(2) Parameter No. 7515 setting \geq remaining distribution count for the current cycle

A number of pulses for retracting until the end of the current cycle are superimposed on a usual operation. When retracting ends, the CNC shifts to an automatic operation pause or retract cycle execution.

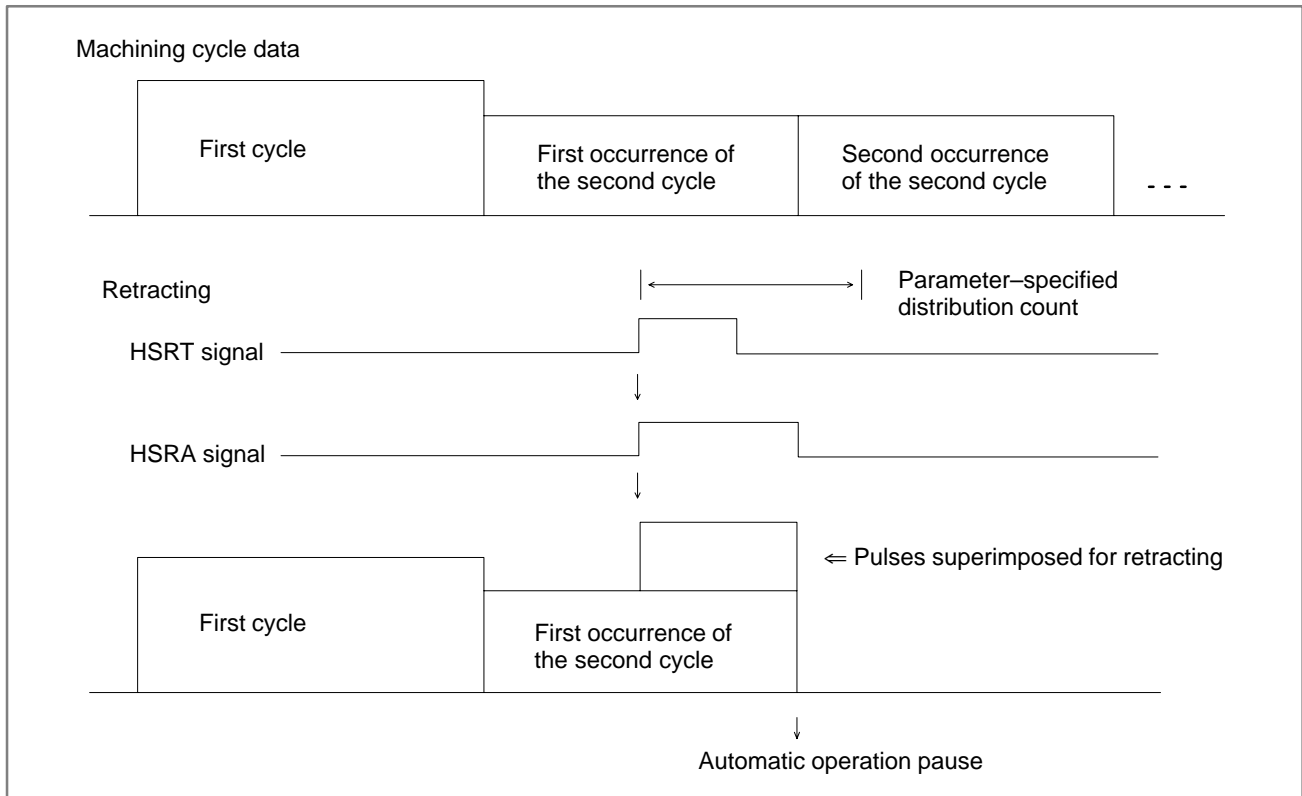

The retract direction and speed for each axis are specified in parameter No. 7514. The sign of the speed represents the direction.

(Example) Parameter No. 7514: X = 10 (for metric machine)
 Y = -20
 Z = 0

Retracting occurs at a speed of 10 mm/min in the positive direction along the X-axis and 20 mm/min in the negative direction along the Y-axis, but does not occur along the Z-axis (0 mm/min).

A reset interrupts retracting.

Retract cycle

Cycle data can be registered with the cycle header. This data is used to move the tool to a safer position or to decelerate high-speed motion about a rotation axis and high-speed travel along other axes.

Enabling retracting can be selected. If retracting is disabled, the retract signal is ignored. In a connection cycle, retracting begins with the first enabled-retracting cycle.

If no retract cycle is registered, the CNC shifts to an automatic operation pause (see Section 5.1) after retracting. If a retract cycle is registered, shifting to an automatic operation pause occurs after the retract cycle is executed.

Registering a retract cycle causes the retract cycle to execute after retracting. It is possible to register different retract cycles for each machining cycle.

A retract cycle is created using the same methods (including the cycle connection, cycle repetition count, and data specification methods) as for ordinary cycles.

The retracting signal HSRA <F062#2> remains 1 during retracting.

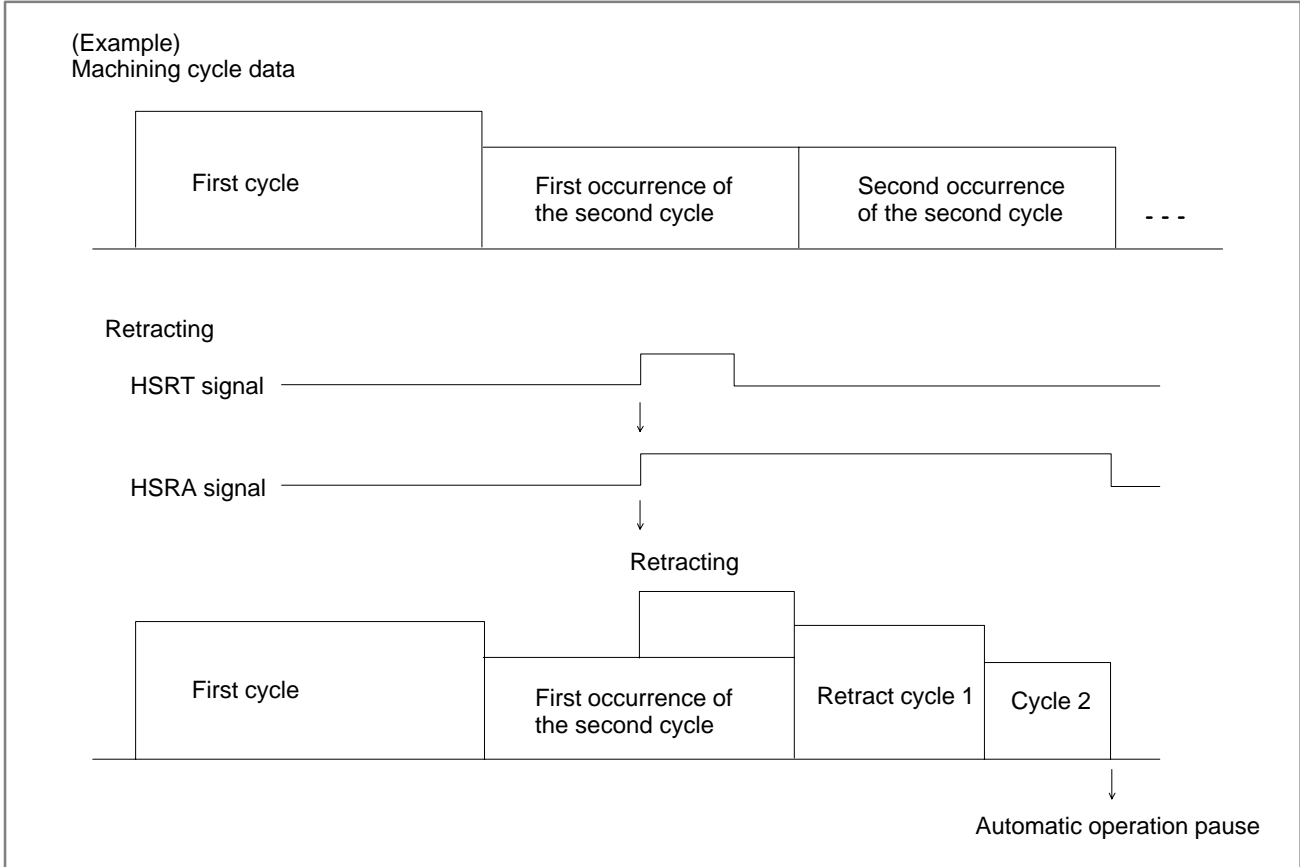

Setting parameter No. 7514 to all 0s makes it possible to execute a retract cycle without retracting (additional retract movement = 0).

A reset interrupts retracting.

Learning control

When retracting begins, a command is issued to disable learning control for all axes.

High-speed cycle header

Bit 7 of the specification variable in the high-speed cycle header specifies whether to enable retracting. If this bit is off, the retract signal HSRT is ignored.

Data type specification variable

15	14	13	12	11	10	9	8	7	6	5	4	3	2	1	0
-	-	r6	r5	r4	r3	r2	r1	RT	-	t6	t5	t4	t3	t2	t1

- RT: Retracting selection flag
- = 0 : Retracting is not performed.
- = 1 : Retracting is performed.

If retracting is enabled (RT = 1), the sixth-axis data specification variable works as the retract cycle connection information. This variable specifies a retract cycle number (1 to 999). If the variable is 0, it is assumed that there is no retract cycle.

NOTE

When the high-speed cycle machining retract function is used, up to five axes can be controlled for high-speed cycle machining.

Header configuration when retracting is enabled

#20001/20017/20033.. (#200001/200017/200033..)	Cycle repetition count		
#20002/20018/20034.. (#200002/200018/200034..)	Cycle connection information		
#20003/20019/20035.. (#200003/200019/200035..)	Data count		
#20004/20020/20036.. (#200004/200020/200036..)	Data type	RT=1	
#20005/20021/20037.. (#200005/200021/200037..)	1st-axis data specification variable		
#20006/20022/20038.. (#200006/200022/200038..)	2nd-axis data specification variable		
#20007/20023/20039.. (#200007/200023/200039..)	3rd-axis data specification variable		
#20008/20024/20040.. (#200008/200024/200040..)	4th-axis data specification variable		
#20009/20025/20041.. (#200009/200025/200041..)	5th-axis data specification variable		
#20010/20026/20042.. (#200010/200026/200042..)	Retract cycle connection information		
#20011/20027/20043.. (#200011/200027/200043..)	1st-axis fixed-data count		
#20012/20028/20044.. (#200012/200028/200044..)	2nd-axis fixed-data count		
#20013/20029/20045.. (#200013/200029/200045..)	3rd-axis fixed-data count		
#20014/20030/20046.. (#200014/200030/200046..)	4th-axis fixed-data count		
#20015/20031/20047.. (#200015/200031/200047..)	5th-axis fixed-data count		
#20016/20032/20048.. (#200016/200032/200048..)	(Not used)		

NOTE

P-code variable numbers enclosed in parentheses apply to data variable addition A/B.

Signal

High-speed cycle machining retract signal HSRT<G065#3>

[Classification] Input signal

[Function] Starts high-speed cycle machining retracting.

[Operation] When this signal becomes 1, the control unit behaves as follows:

- If high-speed cycle machining is under way, and retracting is enabled for the current machining cycle, the control unit begins high-speed cycle machine retracting.

High-speed cycle machining retracting signal HSRA<F062#2>

[Classification] Output signal

[Function] Indicates that high-speed cycle machining retracting is under way.

[Output condition] This signal becomes 1 during:

- High-speed cycle machining retracting or retract cycle.

Signal address

	#7	#6	#5	#4	#3	#2	#1	#0
G065					HRST			
	#7	#6	#5	#4	#3	#2	#1	#0
F062						HSRA		

Parameter

7514	Retract direction and speed for high-speed machining
------	--

[Data type] Two-word axis

	Increment system	Unit of data	Valid data range	
			IS-A, IS-B	IS-C
[Unit of data]				
[Valid data range]				
	Millimeter machine	1 mm/min	-30 to -240000 30 to 240000	-30 to -100000 30 to 100000
	Inch machine	0.01 inch/min	-30 to -96000 30 to 96000	-30 to -4800 30 to 4800

This parameter specifies the retract direction and speed for each axis. The sign of the retract speed represents the direction.

7515

Retracting distribution count for high-speed cycle machining retracting

[Data type] Two-word

This parameter specifies a retracting distance for high-speed cycle machining. If the machining cycle ends before the specified is reached, retracting ends immediately. If this parameter is 0, it is assumed that the retracting distance is indefinite; so retracting continues until the current cycle ends.

Reference item

CONNECTION MANUAL (This manual)	11.5	High-speed cycle machining
------------------------------------	------	----------------------------

11.19 HIGH-SPEED CYCLE MACHINING SKIP FUNCTION

General

This function cancels a repetition cycle operation in high-speed cycle machining and causes a skip to the header information connected next.

Skip signals (HCSKP1 to HCSKP4) sent from a size measuring device (sensor) can be used to skip a currently executed machining cycle.

For continuous high-speed high-precision machining with a cylindrical grinding machine, for example, skip signals from the size measuring device are used when slight tool wear is detected.

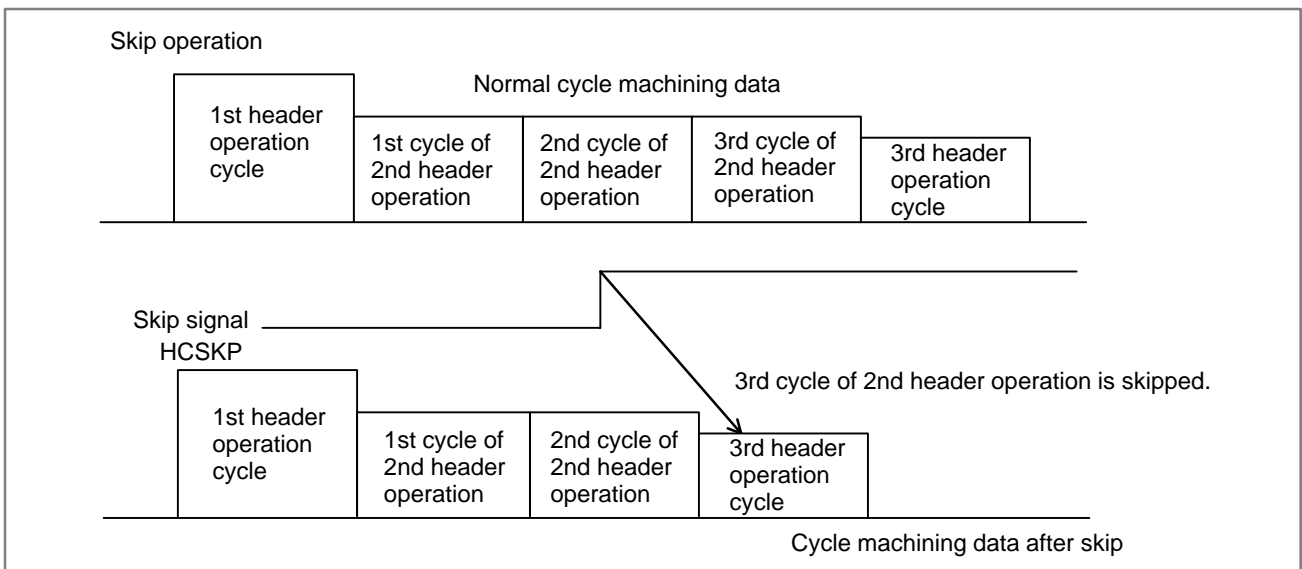
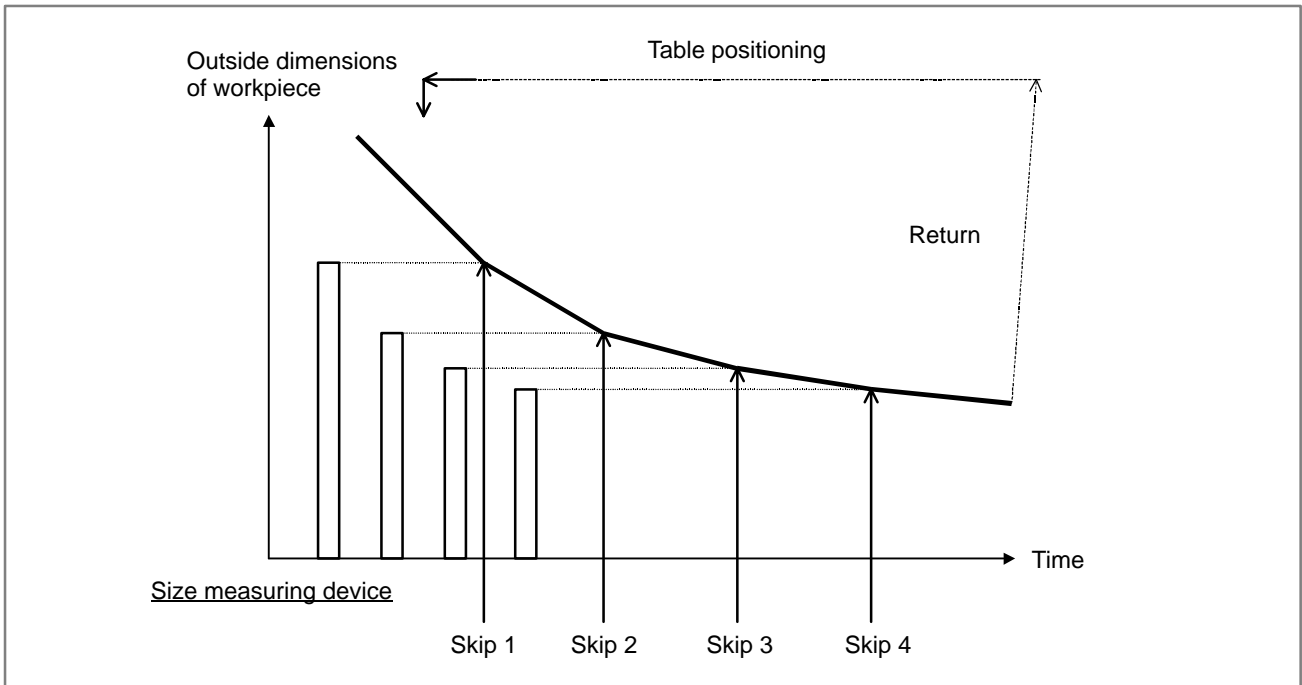

A repetition cycle is canceled, and a skip to the header operation cycle connected next is made. A skip is not performed at a midway point of a cycle operation.

Example

G05P10001L3;

Cycle 1	Connection information 2	Number of repetitions 1
Cycle 2	Connection information 3	Number of repetitions 2
Cycle 3	Connection information 4	Number of repetitions 3
Cycle 4	Connection information 0	Number of repetitions 1

Cycles are executed as follows:

⇒ Normal cycle operation

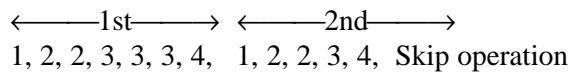
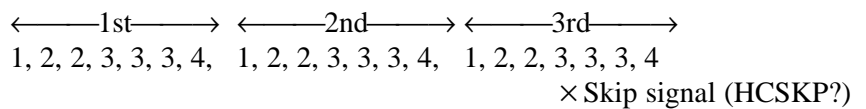

Setting

To perform skip operation, set data corresponding to the four skip signals in bits 6 and 13 to 15 of the data type specification variable in the header.

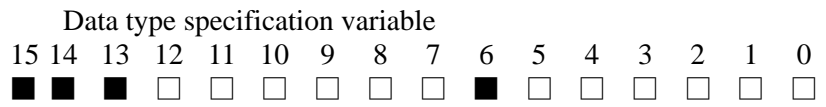

Each bit position corresponds to a skip signal as follows:

Bit position	⇒	Skip signal (G065)	
6	⇒	HCSKP1	
1	⇒	HCSKP2	0: Not specified.
14	⇒	HCSKP3	1: Specified.
15	⇒	HCSKP4	

Example:

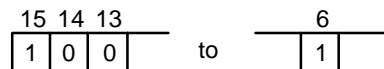

The above setting enables skip operation if either skip signal HCSKP1 or HCSKP4 is 1.

Relationships between the header configuration and P code variable numbers when skip operation is enabled

#20001/20017/20033.. (#200001/200017/200033..)	Cycle repetition count
#20002/20018/20034.. (#200002/200018/200034..)	Cycle connection information
#20003/20019/20035.. (#200003/200019/200035..)	Data count
#20004/20020/20036.. (#200004/200020/200036..)	Data type (Skip signal specification)
#20005/20021/20037.. (#200005/200021/200037..)	1st-axis data specification variable
#20006/20022/20038.. (#200006/200022/200038..)	2nd-axis data specification variable
#20007/20023/20039.. (#200007/200023/200039..)	3rd-axis data specification variable
#20008/20024/20040.. (#200008/200024/200040..)	4th-axis data specification variable
#20009/20025/20041.. (#200009/200025/200041..)	5th-axis data specification variable
#20010/20026/20042.. (#200010/200026/200042..)	Retract cycle connection information
#20011/20027/20043.. (#200011/200027/200043..)	1st-axis fixed-data count
#20012/20028/20044.. (#200012/200028/200044..)	2nd-axis fixed-data count
#20013/20029/20045.. (#200013/200029/200045..)	3rd-axis fixed-data count
#20014/20030/20046.. (#200014/200030/200046..)	4th-axis fixed-data count
#20015/20031/20047.. (#200015/200031/200047..)	5th-axis fixed-data count
#20016/20032/20048.. (#200016/200032/200048..)	Skip cycle connection information

NOTE

- 1 P-code variable numbers enclosed in parentheses apply to data variable addition A/B.
- 2 In the skip cycle connection information variable, be sure to set 0.

Support of learning control

This function supports learning control. Up to five learning data areas are provided. When the cycle operation is changed by a skip signal, the learning data area is also changed.

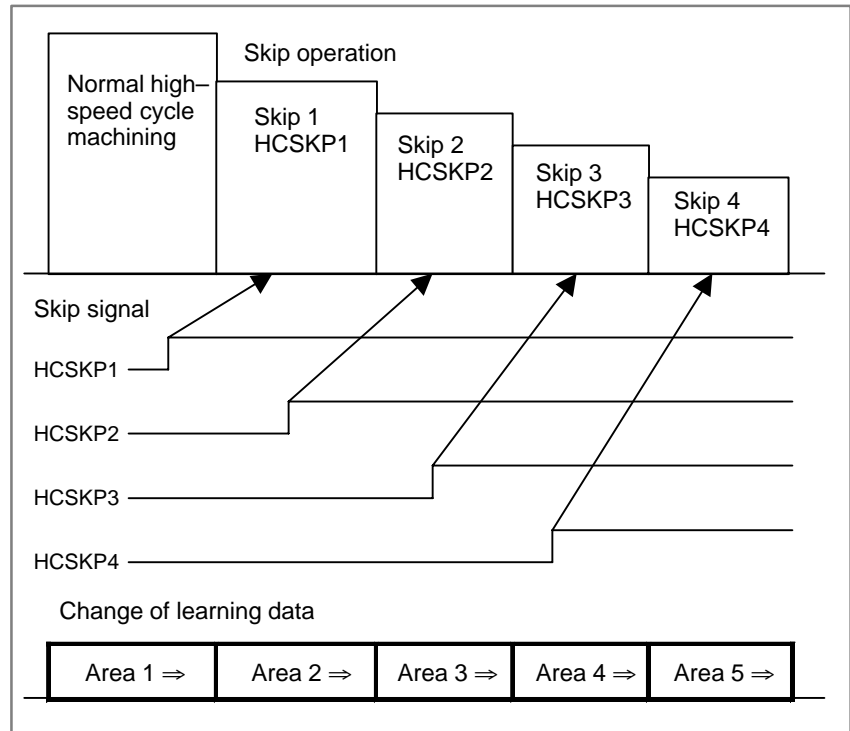

Signal

Skip signals for high-speed cycle machining HCSKP1 to HCSKP4 <G065#4 to G065#7>

[Classification] Input signal

[Function] Causes a high-speed cycle machining skip operation.

[Operation] These signals are set to 1 when:

- High-speed cycle machining is currently performed, and skip operation is enabled for the currently executed cycle. In this case, skip operation is performed.

HCSKP1: Skip signal 1 for high-speed cycle machining

HCSKP2: Skip signal 2 for high-speed cycle machining

HCSKP3: Skip signal 3 for high-speed cycle machining

HCSKP4: Skip signal 4 for high-speed cycle machining

Signal address

	#7	#6	#5	#4	#3	#2	#1	#0
G065	HCSKP4	HCSKP3	HCSKP2	HCSKP1				

Caution**CAUTION**

- 1 Skip operation cannot be performed during emergent return operation of a high-speed cycle.
- 2 For skip operation, the maximum number of axes for high-speed cycle machining is five. If six axes are set, skip operation is not performed.
- 3 In a high-speed cycle machining command, the command specifying the number of repetitions (the L command) becomes invalid after skip operation.
- 4 When the number of repetition cycles is 1, no skip operation is performed.
- 5 If the skip signal is already 1 before the start of cycle machining, skip operation takes place after one-cycle machining.

12

DISPLAY/SET/EDIT



12.1 DISPLAY/SET

12.1.1 Clock Function

General

Time is displayed in the hour/minute/second format on each display screen. Some screens allow display of the year, month, and day. The custom macro system variable can be used to read the time.

Time information can be read and written.

System variables for time information

Variable number	Function
#3001	This variable functions as a timer that counts in 1–millisecond increments at all times. When the power is turned on, the value of this variable is reset to 0. When 2147483648 milliseconds is reached, the value of this timer returns to 0.
#3002	This variable functions as a timer that counts in 1–hour increments when the cycle start lamp is on. This timer preserves its value even when the power is turned off. When 1145324.612 hours is reached, the value of this timer returns to 0.
#3011	This variable can be used to read the current date (year/month/day). Year/month/day information is converted to decimal number. For example, January 23, 2004 is represented as 20040123.
#3012	This variable can be used to read the current time (hours/minutes/seconds). Hours/minutes/seconds information is converted to an apparent decimal number. For example, 34 minutes and 56 seconds after 3 p.m. is represented as 153456.

Reference item

Series 16i/18i/160i/180i/ 160is/180is	OPERATOR'S MANUAL (For Machining Center) (B-63534EN)	III.11.4.5	Displaying and Setting Run Time, Parts Count, and Time
	OPERATOR'S MANUAL (For Lathe) (B-63524EN)	III.11.4.9	Displaying and Setting Run Time, Parts Count, and Time
Series 21i/210i/210is	OPERATOR'S MANUAL (For Machining Center) (B-63614EN)	III.11.4.5	Displaying and Setting Run Time, Parts Count, and Time
	OPERATOR'S MANUAL (For Lathe) (B-63604EN)	III.11.4.9	Displaying and Setting Run Time, Parts Count, and Time
Series 20i	OPERATOR'S MANUAL (For Manual Milling Machine) (B-64204EN)	III.13.4.3	Displaying and Setting Run Time, Parts Count, and Time
	OPERATOR'S MANUAL (For Manual Lathes) (B-64194EN)	III.13.4.6	Displaying and Setting Run Time, Parts Count, and Time

12.1.2 Displaying Operation History

General

This function displays a history of the key stroke and signal operations, performed by the CNC operator, when a failure or CNC alarm occurs.

The following history data is recorded:

- (1) MDI key operation sequences

Example: A ~Z, <POS>, <PAGE ↑>, [SF1]

- (2) On/off status transitions of selected input and output signals

Example: G0000.7↑, SBK ↑

- (3) CNC alarm information

Example: P/S0010

- (4) Time (date, time) stamp

Example: 01/01/20
09:15:30

The history data can be read or written to an input/output device.

Operation history signal selection parameter

Setting bit 4 (OHS) of parameter No. 3206 to 1 enables operation history signals to be selected as parameters and signal selection data to be input/output (read/punched) as parameters. In this case, selecting/deselecting these signals on the operation history signal selection screen causes the corresponding parameter values to change automatically. Changing the parameter values also changes the displays on the operation history signal selection screen.

Signal selection data and corresponding parameters

The input/output signals selected as operation history targets are displayed on the "operation history signal selection screen." Input/output signals can be selected as operation history targets on the "operation history signal selection screen" and, if bit 4 of parameter No. 3206 is 1, they can be specified directly using parameters. Up to 20 addresses can be used for signal selection. Selecting one signal uses three types of data, that is, a signal type (X, G, F, or Y), address, and bit. These data types correspond to parameters as listed below.

Table 12.1.2(a) Signal selection data and corresponding parameters

No.	Signal type	Address	Bit
01	No.12801	No.12841	No.12881
02	No.12802	No.12842	No.12882
03	No.12803	No.12843	No.12883
...
20	No.12820	No.12860	No.12900

The following table lists parameter values for respective signal types.

Table 12.1.2(b) Signal types and corresponding parameter values

Signal type	Parameter value
Not selected	0
G0000 to G0255	1
G1000 to G1255	2
F0000 to F0255	3
F1000 to F1255	4
Y0000 to Y0127	5
X0000 to X0127	6
G2000 to G2255	9
F2000 to F2255	10

Method of selecting signals based on parameters

The following explains how to use parameters to select signals as operation history targets.

Procedure

- 1 Set bit 4 of parameter No. 3206 to 1. The current operation history signal selection data is reflected to parameters.
- 2 Determine which parameter No. to be set while referencing Table 1.
- 3 Select or deselect signal types (from parameter Nos. 12801 to 12820) while referencing Table 2. To deselect a signal type, reset the related parameter to 0 (the address and bit combined with the parameter that is reset are reset simultaneously with that parameter). When a signal type is selected, the parameter for setting the address combined with that signal type is set to a minimum possible value, and the parameter for setting the bit combined with that signal type is initialized to 0. If an attempt is made to specify an invalid value, the warning message "Data out of range" is displayed; so, you should retry.
- 4 Set up an address (parameter Nos. 12841 to 12860). Setting up an address causes the parameter for setting the bit combined with that address to be initialized to 0. If an attempt is made to set an invalid value, or the parameter for setting the parameter type combined with that address is 0, the warning message "Data out of range" is displayed; so, you should retry.
- 5 Set or reset bits (Nos. 12881 to 12900). To select a signal as a history target, set the related bit to 1. Otherwise, reset it to 0. If the parameter for setting a signal type combined with that bit is 0, the warning message "Data out of range" is displayed; so, you should retry.
- 6 To continue signal selection, repeat steps 2 to 5.

Example: To select the automatic operation start signal (G7.2) as operation history target No. 2, set up the related parameters as listed below:

No.12802=1

No.12842=7

No.12882=00000100

If parameter No. 12802 is 1, parameter Nos. 12842 and 12882 are initialized to 0. If parameter No. 12842 is 7, parameter No. 12882 is initialized to 0. Be sure to set parameter Nos. 12802, 12842, and 12882 in the stated sequence.

Caution

CAUTION

A parameter clear operation (turning the power on with the <RESET> key held) down does not deselect signals from operation history targets. To deselect them, perform a release operation ([DELET] or [ALLDEL] soft keys) on the "operation history signal selection screen" or, when bit 4 of parameter No. 3206 is 1, reset parameter Nos. 12801 to 12820 to 0.

Parameter

	#7	#6	#5	#4	#3	#2	#1	#0
3106	OHS			OHD				

[Data type] Bit

OHD The operation history screen is:

0 : Not displayed.

1 : Displayed.

OHS Operation history sampling is:

0 : Performed.

1 : Not performed.

NOTE

Usually, set OHS = 0 (Performed).

	#7	#6	#5	#4	#3	#2	#1	#0
3112			OPH					

NOTE

CNC power must be cycled for this parameter to take effect.

OPH Enable the operation history function.

0 : Enabled.

1 : Disabled.

3122	Time interval used to record data in the operation history
------	--

[Data type] Word

[Unit of data] Minutes

[Valid data range] 0 to 1439

Time data is recorded in the operation history at set intervals. When 0 is specified in this parameter, 10 minutes is assumed as the default.

	#7	#6	#5	#4	#3	#2	#1	#0
3206				OHS				

[Data type] Bit

- OHS** 0 : Operation history signal selection is not linked to parameters. Signals are selected as or deselected from operation history targets on the operation history signal selection screen. Changing any parameter does not affect operation history signal selection.
- 1 : Operation history signal selection is linked to parameters. Operation history signal selection can be made both on the operation history signal selection screen and through parameters.

NOTE

Setting this parameter to 1 causes the current operation history signal selection data to be reflected to parameter Nos. 12801 to 12900.

12801	Operation history signal selection signal type (No. 01)
12802	Operation history signal selection signal type (No. 02)
12803	Operation history signal selection signal type (No. 03)
:	:
12820	Operation history signal selection signal type (No. 20)

[Data type] Byte

[Valid data range] 0 to 10

Specify signal types for operation history signal selection. The following table lists the signal types and corresponding parameter values.

Signal type	Parameter value
Not selected	0
G0000 to G0255	1
G1000 to G1255	2
F0000 to F0255	3
F1000 to F1255	4
Y0000 to Y0127	5

Signal type	Parameter value
X0000 to X0127	6
Y1000 to Y1063	7
X1000 to X1063	8
G2000 to G2255	9
F2000 to F2255	10

To deselect a signal type, reset the related parameter to 0 (the address and bit combined with the parameter that is reset are reset simultaneously with that parameter). When a signal type is selected, the parameter for setting the address combined with the parameter for selecting the signal type is set to a minimum possible value, and the parameter for setting the bit combined with that parameter is initialized to 0.

Example) If parameter No. 12801 is 2, parameter Nos. 12841 and 12881 are initialized, respectively, to 1000 and 00000000.

If an attempt is made to specify an invalid value, the warning message "Data out of range" is displayed; so, you should retry.

12841	Operation history signal selection address (No. 01)
12842	Operation history signal selection address (No. 02)
12843	Operation history signal selection address (No. 03)
:	:
12860	Operation history signal selection address (No. 20)

[Data type] Word

[Valid data range] 0 to 255

Set up addresses for operation history signal selection. Setting up an address causes the parameter for setting the bit combined with that address to be initialized to 0. If an attempt is made to set an invalid value, or the parameter for setting the parameter type combined with that address is 0, the warning message "Data out of range" is displayed; so, you should retry.

	#7	#6	#5	#4	#3	#2	#1	#0	
12881									(No. 01)
12882									(No. 02)
12883									(No. 03)
:									
12900									(No. 20)

[Data type] Bit

Set or reset bits for operation history signal selection. To select a signal as a history target, set the related bit to 1. Otherwise, reset it to 0. If the parameter for setting a signal type combined with that bit is 0, the warning message "Data out of range" is displayed; so, you should retry.

Note**NOTE**

- 1 While the operation history screen is displayed, history data is not recorded.
- 2 When the duration of the on/off state of an input signal is 16 msec or shorter, that state is not recorded in the history. In addition, some signals are not recorded.
- 3 Approximately 8000 keystrokes can be stored in the memory.
- 4 Recorded history data is held in memory even after the power is turned off. Clearing memory will erase the history data.
- 5 For the operation history function, sampling is disabled when bit 7 (OHS) of parameter No. 3106 is set to 1.
- 6 Be careful to set the date and time correctly.
If no data exists in the regular recording interval, then this time period is not recorded.
To input and output operation history data, the reader/punch interface option is required.

12.1.3 Help Function

General

The help function displays on the screen detailed information about alarms issued in the CNC and about CNC operations.

- **Detailed information of alarms**

The help screen displays detailed information about the alarms and how to recover from them. The detailed information is displayed only for a limited number of P/S alarms. These alarms are often misunderstood and are rather difficult to understand.

- **Operation method**

If you are not sure about a CNC operation, refer to the help screen for information about each operation.

- **Parameter table**

The help screen displays a list of parameter Nos. for each function, as an aid.

Note**NOTE**

The user cannot switch the screen display from the PMC screen or CUSTOM screen to the help screen.

Reference item

Series 16i/18i/160i/180i/ 160is/180is	OPERATOR'S MANUAL (For Machining Center) (B-63534EN)	III.13	HELP FUNCTION
	OPERATOR'S MANUAL (For Lathe) (B-63524EN)	III.13	HELP FUNCTION
Series 21i/210i/210is	OPERATOR'S MANUAL (For Machining Center) (B-63614EN)	III.13	HELP FUNCTION
	OPERATOR'S MANUAL (For Lathe) (B-63604EN)	III.13	HELP FUNCTION
Series 20i	OPERATOR'S MANUAL (For Manual Milling Machine) (B-64204EN)	III.15	HELP FUNCTION
	OPERATOR'S MANUAL (For Manual Lathes) (B-64194EN)	III.15	HELP FUNCTION

12.1.4 Displaying Alarm History

General

Up to 25 of the most recent CNC alarms are stored and displayed on the screen.

The following items are displayed for each alarm easily.

- (1) The date the alarm was issued
- (2) Alarm No.
- (3) Alarm message (some contains no message)

Reference item

Series 16i/18i/160i/180i/ 160is/180is	OPERATOR'S MANUAL (For Machining Center) (B-63534EN)	III.7.2	ALARM HISTORY DISPLAY
	OPERATOR'S MANUAL (For Lathe) (B-63524EN)	III.7.2	ALARM HISTORY DISPLAY
Series 21i/210i/210is	OPERATOR'S MANUAL (For Machining Center) (B-63614EN)	III.7.2	ALARM HISTORY DISPLAY
	OPERATOR'S MANUAL (For Lathe) (B-63604EN)	III.7.2	ALARM HISTORY DISPLAY
Series 20i	OPERATOR'S MANUAL (For Manual Milling Machine) (B-64204EN)	III.7.2	ALARM HISTORY DISPLAY
	OPERATOR'S MANUAL (For Manual Lathes) (B-64194EN)	III.7.2	ALARM HISTORY DISPLAY

12.1.5 Servo Tuning Screen

General

On the servo tuning screen, parameters for each axis are listed for the basic adjustment of the servo motor.

Parameter

	#7	#6	#5	#4	#3	#2	#1	#0
3111								SVS

[Data type] Bit

SVS Servo tuning screen

0 : Not displayed

1 : Displayed

Reference item

Series 16i/18i/21i/160i/ 180i/210i/160is/ 180is/210is	MAINTENANCE MANUAL (B-63525EN)	5.2	Servo Tuning Screen
--	-----------------------------------	-----	---------------------

12.1.6 Spindle Setting and Tuning Screen

General

On the spindle setting and tuning screen, parameters are listed for the basic adjustment of the serial spindle. The screen is only for the main spindle connected to the first amplifier.

Parameter

	#7	#6	#5	#4	#3	#2	#1	#0
3111						SVP	SPS	

[Data type] Bit type

SPS Spindle setting and tuning screen

0 : Not displayed

1 : Displayed

SVP Display of spindle data

0 : Instantaneous values are displayed.

1 : Peak-hold values are displayed.

Reference item

Series 16i/18i/21i/160i/ 180i/210i/160is/ 180is/210is	MAINTENANCE MANUAL (B-63525EN)	6.4	Spindle setting and tuning screen
--	-----------------------------------	-----	--------------------------------------

12.1.7 Waveform Diagnosis Display

General

Waveform diagnosis is classified into two main types.

(1) One-shot type

One-shot waveform diagnosis provides graphs of waveforms.

In one-shot waveform diagnosis, the start of data collection can be triggered by the rising or falling edge of a machine signal.

This function is designed to facilitate the adjustment of servo motors and spindle motors, and includes the following.

- a. Servo motor error value along each axis, number of distributed pulses, torque, feedrate, current, and thermal simulation data
- b. Combined feedrate for the first, second, and third axes
- c. Spindle motor speed, load meter reading, and position deviation, converted to spindle position
- d. On/off status of the machine signal, specified by a signal address

(2) Stored type

In stored waveform diagnosis, changes in the following data are recorded. When a servo alarm is issued, the recorded data can be read and displayed graphically as waveforms.

The end of data collection can be triggered by the rising or falling edge of a machine signal.

This function is designed to facilitate the determination of a fault.

Stored data can be output via the reader/punch interface, and includes:

- a. Servo motor error value along each axis, number of distributed pulses, torque, feedrate, current, and thermal simulation data

Parameter

	#7	#6	#5	#4	#3	#2	#1	#0
3112								SGD

[Data type] Bit

SGD Servo waveform

0 : Not displayed

1 : Displayed

NOTE

When this parameter is set, CNC power must be cycled.

3120

Time from the output of an alarm to the termination of sampling

[Data type] Word**[Unit of data]** ms**[Valid data range]** 1 to 32760

When the waveform diagnosis function is used, this parameter sets the time from the output of a servo alarm until data collection. Storage operation is stopped because of the alarm. (This means that the termination of data collection can be delayed by a specified time.)

Note
NOTE

- 1 Once the memory area becomes full, the oldest data is deleted to allow new data.
- 2 Waveform diagnosis data is held in memory even after the power is turned off.
- 3 Be careful to set the date and time correctly.
- 4 To output stored type waveform data, the reader/punch interface option is required.
- 5 Waveform diagnosis is enabled when bit 0 (SGD) of parameter No. 3112 is set to 1. To perform waveform diagnosis, a graphics card is required.
Usual graphic display function can not be used when waveform diagnosis is enable.

Reference item

Series 16i/18i/21i/160i/ 180i/210i/160is/ 180is/210is	MAINTENANCE MANUAL (B-63525EN)	1.8	Waveform diagnostic display
--	-----------------------------------	-----	-----------------------------

12.1.8 Self-diagnosis

General

To determine the cause of an alarm, check the following.

First, it has to be determined if the breakdown is in the CNC, the PMC or the machine.

The CNC checks the following.

- 1) Abnormality of detection system
- 2) Abnormality of position control unit
- 3) Abnormality of servo system
- 4) Overheat
- 5) Abnormality of CPU
- 6) Abnormality of ROM
- 7) Abnormality of RAM
- 8) Abnormality in data transfer between MDI
- 9) Abnormality of part program storage memory
- 10) Abnormality in tape reader read function
- 11) Abnormality in data transfer between PMC

Input/output signals between the PMC and the CNC, and the CNC status can be displayed on the screen.

Reference item

Series 16i/18i/160i/180i/ 160is/180is	OPERATOR'S MANUAL (For Machining Center) (B-63534EN)	III.7.3	CHECKING BY SELF-DIAG- NOSTIC SCREEN
	OPERATOR'S MANUAL (For Lathe) (B-63524EN)	III.7.3	CHECKING BY SELF-DIAG- NOSTIC SCREEN
Series 21i/210i/210is	OPERATOR'S MANUAL (For Machining Center) (B-63614EN)	III.7.3	CHECKING BY SELF-DIAG- NOSTIC SCREEN
	OPERATOR'S MANUAL (For Lathe) (B-63604EN)	III.7.3	CHECKING BY SELF-DIAG- NOSTIC SCREEN
Series 20i	OPERATOR'S MANUAL (For Manual Milling Machine) (B-64204EN)	III.7.3	CHECKING BY SELF-DIAG- NOSTIC SCREEN
	OPERATOR'S MANUAL (For Manual Lathes) (B-64194EN)	III.7.3	CHECKING BY SELF-DIAG- NOSTIC SCREEN

12.1.9 Display of Hardware and Software Configuration

General

The required hardware/software configuration for the CNC can be displayed on the screen.

The system configuration screen displays the following information:

(1) Printed circuit board configuration

- a. The type and function of the printed circuit board mounted in each slot.
- b. When a CPU is mounted on a printed circuit board, the software series and edition are displayed.

(2) Software configuration

The series and editions of installed software, including the CNC software, servo software, PMC management software, and ladder programs, are displayed. For the CNC software, assembly information is also displayed.

(3) Module configuration

The configuration of the modules or hardware mounted on each printed circuit board (such as the type of a module, and where it is mounted) is displayed.

Reference item

Series 16i/18i/21i/160i/ 180i/210i/160is/ 180is/210is	MAINTENANCE MANUAL (B-63525EN)	1.3	System Configuration Screen
Series 20i	MAINTENANCE MANUAL (B-64195EN)	1.3	System Configuration Screen

12.1.10 Position Display Neglect

General

Disabling the current position display is accomplished by setting bit 0 (NDPx) of parameter No. 3115.

Bit 1 (NDAx) of parameter No. 3115 enables the display of positions in the machine coordinate system.

Signal

Position Display Neglect Signal NPOS1 to NPOS8<G198>

[Classification] Input signal

[Function] Disables the display of the current position.

A separate signal is provided for each controlled axis. The number at the end of each signal name denotes the controlled axis number.

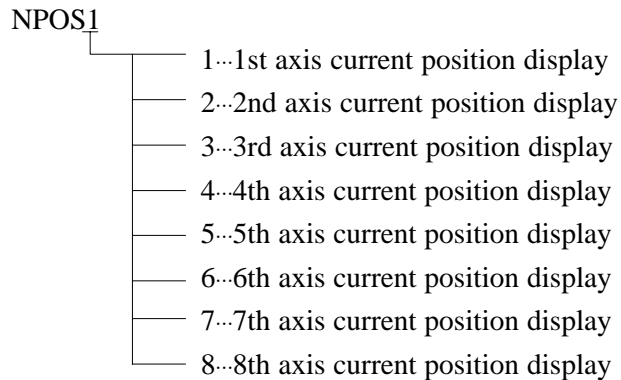

[Operation] When a signal is set to 0, the current position in the corresponding axis is displayed. When the signal is set to 1, the current position and its corresponding axis is not displayed.

Signal address

	#7	#6	#5	#4	#3	#2	#1	#0
G198	NPOS8	NPOS7	NPOS6	NPOS5	NPOS4	NPOS3	NPOS2	NPOS1

Parameter

	#7	#6	#5	#4	#3	#2	#1	#0
3115							NDAx	NDPx

[Data type] Bit axis

NDPx Display of the current position for each axis

0 : The current position is displayed.

1 : The current position is not displayed.

NDAx Position display using absolute coordinates and relative coordinates is:

0 : Performed.

1 : Not performed. (Machine coordinates are displayed.)

12.1.11 Run Hour and Parts Count Display

General

This function displays the integrated power-on time, the integrated cycle operation time, the integrated cutting time and timer (started by an input signal from PMC) on the screen. The integrated cycle operation time, the integrated cutting time and timer can be altered and preset, by the operator.

In addition to the above, this function displays the count of the total number of parts machined, the number of parts required and the number of completed parts on the screen. Each time M02, M30 or a parameter set M code is executed, the count of the total number of parts machined and the number of parts completed is incremented by 1.

If a program is prepared so as to execute M02, M30 or a parameter set M code each time one part machining is completed, the number of parts machined can be counted automatically.

If the count of the number of parts machined reaches the number of parts required, a signal is output to the PMC side.

It is possible for the operator to change and preset the number of parts required and the number of parts completed.

Signal

Target part count reached signal PRTSF<F062#7>

[Classification] Output signal

[Function] Reports to the PMC that the specified number of parts have been machined.

[Output condition] The PRTSF signal is set to 1 when:

- Machining of the specified number of parts has been completed.
When the required number of parts is zero, this signal is not set.

The PRTSF signal is set to 0 when:

- Machining of the specified number of parts has not yet been completed.
 - The system is reset.
-

General-purpose integrating meter start signal TMRON <G053#0>

[Classification] Input signal

[Function] The CNC has an meter which is started by an input signal from the PMC. Additionally, there are meters for counting the automatic operation time and counting cutting time. The count for these meter can be displayed on the screen. The count can be preset by the operator.

[Operation] When the signal is set to 1, the meter starts counting.

Signal address

	#7	#6	#5	#4	#3	#2	#1	#0
G053								TMRON
F062	PRTSF							

Parameter

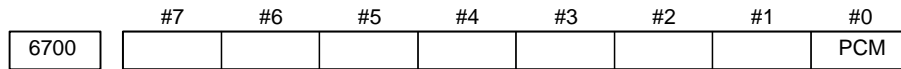

[Data type] Bit

PCM M code that counts the total number of machined parts and the number of completed parts

0 : M02, or M30, or an M code specified by parameter No. 6710

1 : Use only the M code specified by parameter No. 6710 and not M02 or M30

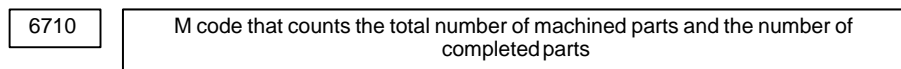

[Data type] Byte

[Valid data range] 0 to 255 except 98 and 99

The total number of machined parts and the number of completed parts are counted (+1) when the M code set is executed.

NOTE

A value of 0 is invalid (the number of parts is not counted for M00). Data 98 and 99 cannot be set.

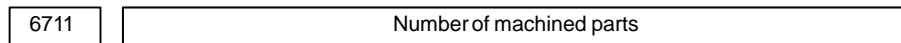

This parameter can be entered on the setting screen.

[Data type] Two-word

[Unit of data] One piece

[Valid data range] 0 to 99999999

The number of machined parts is counted (+1) together with the total number of completed parts when the M02, M30, or a M code specified by parameter No. 6710 is executed.

NOTE

When bit 0 (PCM) of parameter No. 6700 is set to 1, the number of parts is not counted with M02 and M30.

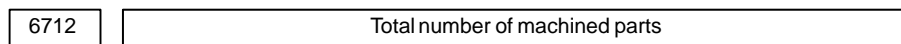

This parameter can be entered on the setting screen.

[Data type] Two-word

[Unit of data] One piece

[Valid data range] 0 to 99999999

This parameter sets the total number of machined parts. The total number of machined parts is counted (+1) when M02, M30, or an M code specified by parameter No. 6710 is executed.

NOTE

When bit 0 (PCM) of parameter No. 6700 is set to 1, the number of parts is not counted with M02 and M30.

6713	Number of required parts
------	--------------------------

This parameter can be entered on the setting screen.

[Data type] Word

[Unit of data] One piece

[Valid data range] 0 to 9999

This parameter sets the number of required parts.

Required parts finish signal PRTSF is output to the PMC when the number of machined parts reaches the number of required parts. The number of parts is regarded as infinity when the number of required parts is zero. The PRTSF signal is then not output.

6750	Integrated value of power-on period
------	-------------------------------------

This parameter can be entered on the setting screen.

[Data type] Two-word

[Unit of data] One minute

[Valid data range] 0 to 99999999

This parameter displays the accumulated time when the machine is powered.

6751	Operation time (integrated value of time during automatic operation)
------	--

This parameter can be entered on the setting screen.

[Data type] Two-word

[Unit of data] One ms

[Valid data range] 0 to 60000

6752	Operation time (integrated value of time during automatic operation)
------	--

This parameter can be entered on the setting screen.

[Data type] Two-word

[Unit of data] One minute

[Valid data range] 0 to 99999999

This parameter displays the accumulated time during automatic operation (neither stop nor hold time included).

The actual operation time is the sum of the values set in parameter Nos. 6751 and 6752.

6753	Accumulated cutting time
------	--------------------------

This parameter can be entered on the setting screen.

[Data type] Two-word

[Unit of data] One ms

[Valid data range] 0 to 60000

6754	Accumulated cutting time
------	--------------------------

This parameter can be entered on the setting screen.

[Data type] Two-word

[Unit of data] One minute

[Valid data range] 0 to 99999999

This parameter displays the accumulated cutting time that is performed in machine feed such as linear interpolation (G01) and circular interpolation (G02 or G03).

The actual cutting time is the sum of the values set in parameter Nos. 6753 and 6754.

6755	Accumulated time of meter drive signal (TMRON) ON
------	---

This parameter can be entered on the setting screen.

[Data type] Two-word

[Unit of data] One ms

[Valid data range] 0 to 60000

6756	Accumulated time of meter drive signal (TMRON) ON
------	---

This parameter can be entered on the setting screen.

[Data type] Two-word

[Unit of data] One minute

[Valid data range] 0 to 99999999

This parameter is accumulated time while input PMC signal TMRON is on.

The actual accumulated time is the sum of the values set in parameter Nos. 6755 and 6756.

6757	Operationtime (accumulated automatic operation time)
------	--

This parameter can be entered on the setting screen.

[Data type] Two-word

[Unit of data] One ms

[Valid data range] 0 to 60000

6758	Operationtime (accumulated automatic operation time)
------	--

This parameter can be entered on the setting screen.

[Data type] Two-word

[Unit of data] One minute

[Valid data range] 0 to 99999999

This parameter is the automatic operation drive time (neither stop nor hold state included). The actual operation time is the sum of the values set in parameter Nos. 6757 and 6758. The operation time is automatically preset to 0 during the power-on sequence.

Reference item

Series 16i/18i/160i/180i/ 160is/180is	OPERATOR'S MANUAL (For Machining Center) (B-63534EN)	III.11.4.5	Displaying and Setting Run Time, Parts Count, and Time
	OPERATOR'S MANUAL (For Lathe) (B-63524EN)	III.11.4.9	Displaying and Setting Run Time, Parts Count, and Time
Series 21i/210i/210is	OPERATOR'S MANUAL (For Machining Center) (B-63614EN)	III.11.4.5	Displaying and Setting Run Time, Parts Count, and Time
	OPERATOR'S MANUAL (For Lathe) (B-63604EN)	III.11.4.9	Displaying and Setting Run Time, Parts Count, and Time
Series 20i	OPERATOR'S MANUAL (For Manual Milling Machine) (B-64204EN)	III.13.4.3	Displaying and Setting Run Time, Parts Count, and Time
	OPERATOR'S MANUAL (For Manual Lathes) (B-64194EN)	III.13.4.6	Displaying and Setting Run Time, Parts Count, and Time

12.1.12 Graphic Display/ Dynamic Graphic Display/Background Graphic

General

Graphic Display

It is possible to draw the programmed tool path on the screen, and check the progress of machining.

In addition, it is also possible to enlarge/reduce the drawing.

The drawing coordinates (parameter) and graphic parameters must be set before a tool path can be displayed.

With the T series (two-path control), the tool paths of both tool posts are displayed on the same screen.

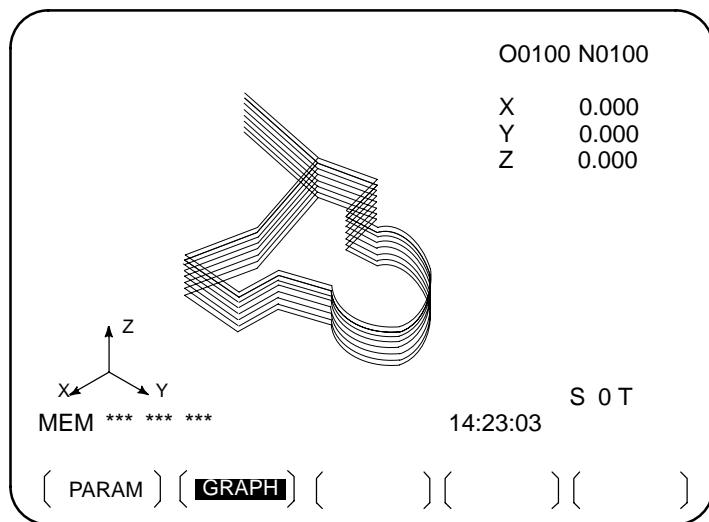

M series

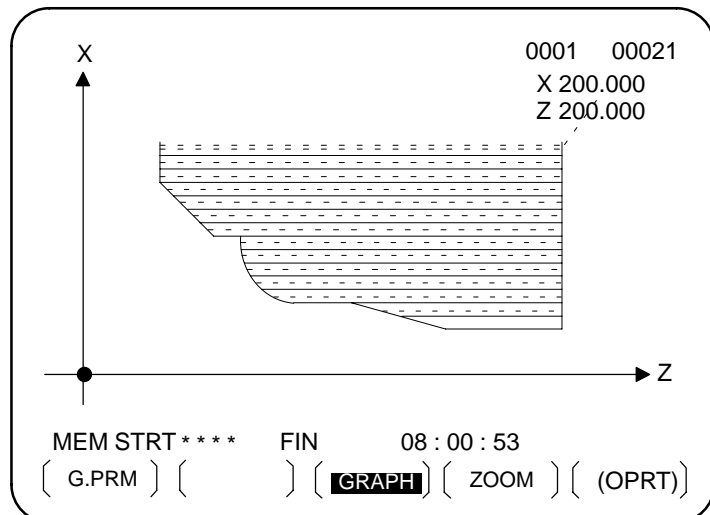

T series

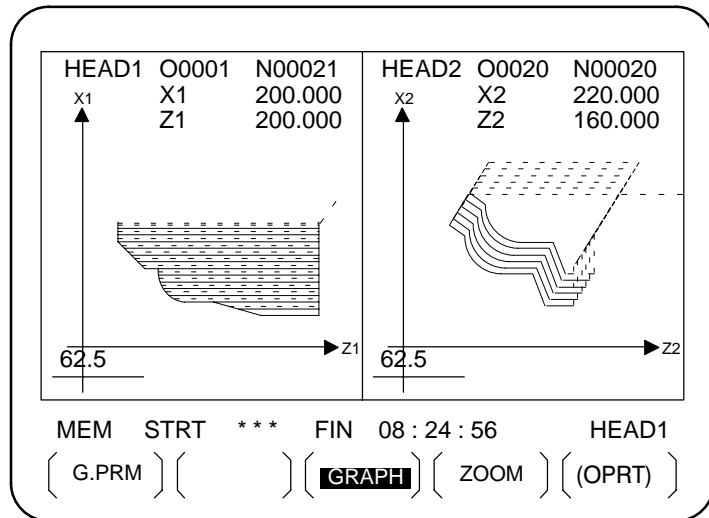

T series (Two-path control)

Dynamic graphic display (M series)

There are two functions of Dynamic Graphics.

Path graphic	This is used to draw the path of the tool center.
Solid graphic	This is used to draw the workpiece figure machined by the tool movement.

The path graphic function is used to precisely check the part program. The solid graphic function is used to draw the workpiece figure to be machined by a program. Switching between the two functions is possible.

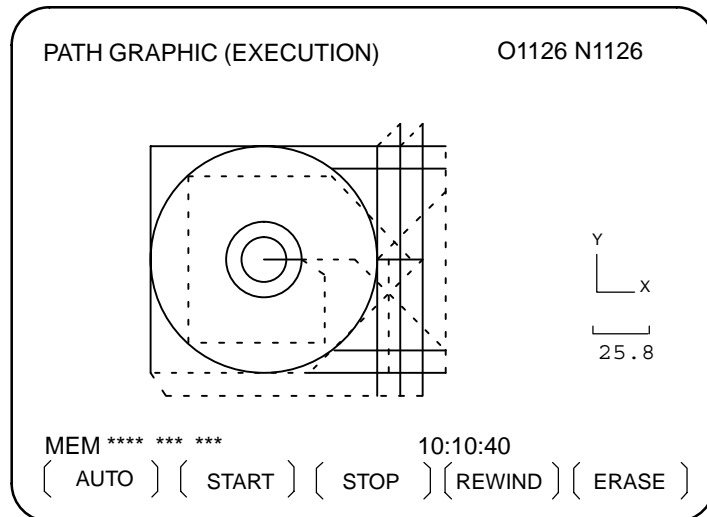

Tool path Graph

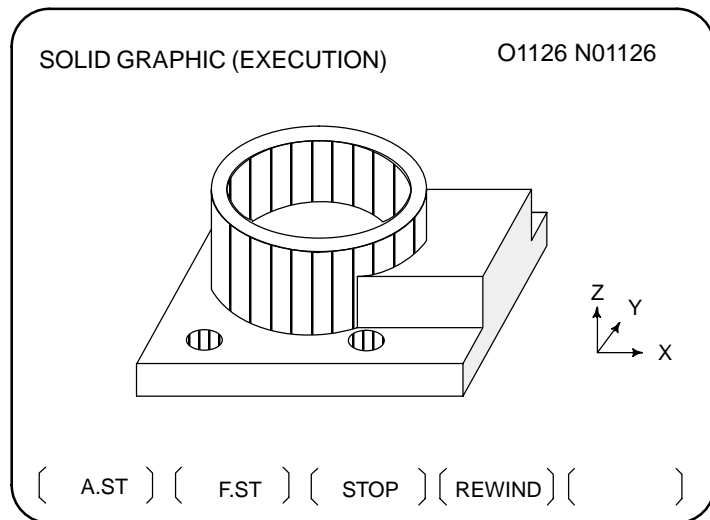

Part Machined

Background graphic (M series)

The background graphic function allows a programmed tool path to be drawn on the screen while machining is being performed by another program.

When the background graphic mode is set, the previously selected program remains selected. The tool path of a selected program can be drawn on the background graphic screen.

The parameters used in actual machining are also used in background graphic mode. Setting and drawing with the background graphic function are the same as with the dynamic graphic display function.

Signal

**Check drawing-under-way signal
CKGRP <F062#5>**

[Classification] Output signal

[Function] Indicates that a dynamic graphics display (animated graphics display) is being drawn for check purposes.

[Operation] The signal becomes 1 when:

- Check drawing begins.

The signal becomes 0 when:

- A reset occurs after check drawing has ended.

Signal address

	#7	#6	#5	#4	#3	#2	#1	#0
F062			CKGRP					

Parameter

	#7	#6	#5	#4	#3	#2	#1	#0
3003	MVG							

[Data type] Bit

MVG While drawing using the dynamic graphics function (with no machine movement), the axis-in-movement signal is:

0 : Output

1 : Not output

	#7	#6	#5	#4	#3	#2	#1	#0
3109								
		BGO						

BGO Response to pressing the <OFFSET/SETTING> function key on the background graphic screen

0 : Returns the display to the machining screen.

1 : Displays the background graphic offsets, offsets in the workpiece coordinate system, and macro variables.

(In this case, "BGGRP" appears in the bottom right corner of the screen. The background graphic data can be checked.)

	#7	#6	#5	#4	#3	#2	#1	#0
6500		NZM			DPA	GUL	SPC	GRL
			DPO					

[Data type] Bit

GRL Graphic display (two-path control lathe)

0 : Path 1 is displayed on the left, and path 2 is displayed on the right.

1 : Tool post 1 is displayed on the right, and tool post 2 is displayed on the left.

SPC Graphic display (two-path control lathe) uses

0 : on two spindles and two tool posts

1 : on one spindle and two tool posts

GUL 0 : The positions of X1- and X2-axes are not reversed in the coordinate system specified with parameter 6509.

1 : The positions of X1- and X2-axes are reversed in the coordinate system specified with parameter 6509. (2-path control)

NOTE

This parameter is used for two-path control lathe.

DPA Current position display on the graphic display screen

0 : Displays the actual position with tool nose radius compensation

1 : Displays the programmed position

DPO Current position on the workpiece drawing or tool path drawing screen

0 : Is not displayed

1 : Displayed

When the background graphic function is used, modal information items F, S, T, and current position are displayed. When the [POS] soft key is selected in dynamic graphic display mode, only the current position is displayed.

NZM 0 : Screen image enlargement by a conventional method is enabled.

1 : The screen image is enlarged by specifying the center of the screen and the magnification. (Screen image enlargement by the conventional method is disabled.)

	#7	#6	#5	#4	#3	#2	#1	#0
6501			CSR					
			CSR	FIM	RID	3PL	TLC	ORG

[Data type] Bit

ORG Movement when coordinate system is altered during drawing

0 : Draws in the same coordinate system

1 : Draws in the new coordinate system (only for the path drawing)

TCL Solid drawing

0 : Do not compensate for the tool length

1 : Compensates for the tool length

3PL Tri-plane drawing in solid drawing

0 : Drawn by the first angle

1 : Drawn by the third angle

RID In solid drawing

0 : Draws a plane without edges.

1 : Draws a plane with edges.

FIM Machining profile drawing in solid drawing

0 : Displays in the coarse mode

1 : Displays in the fine mode

CSR While the screen image is enlarged, the shape of the graphic cursor is:

0 : A square. (■)

1 : An X. (×)

6509

Coordinatesystem for drawing a single spindle (2-path control)

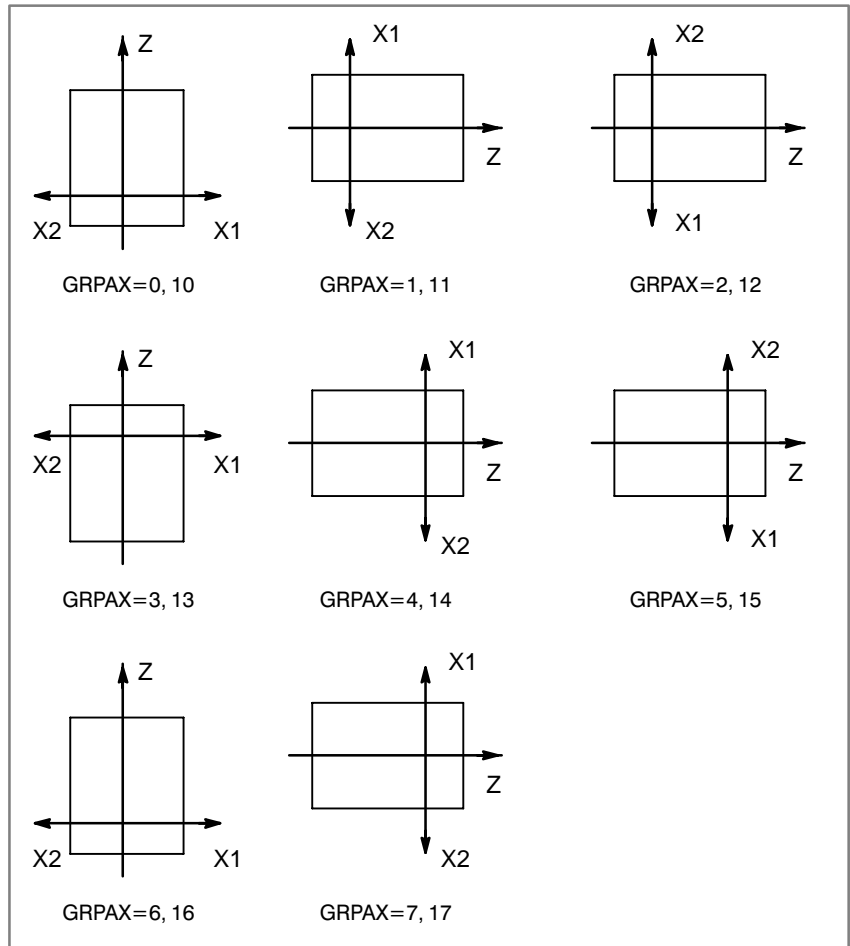
**[Data type]** Byte**[Valid data range]** 0 to 7 and 10 to 17 (0 to 7 are the same settings as 10 to 17.)

This parameter sets the coordinate system for drawing a single spindle (bit 1 of parameter 6500 = 1) for a 2-path control.

6510	Drawing coordinate system
------	---------------------------

[Data type] Byte

[Valid data range] 0 to 7

This parameter specifies the drawing coordinate system for the graphic function.

The following show the relationship between the parameter values and the drawing coordinate systems.

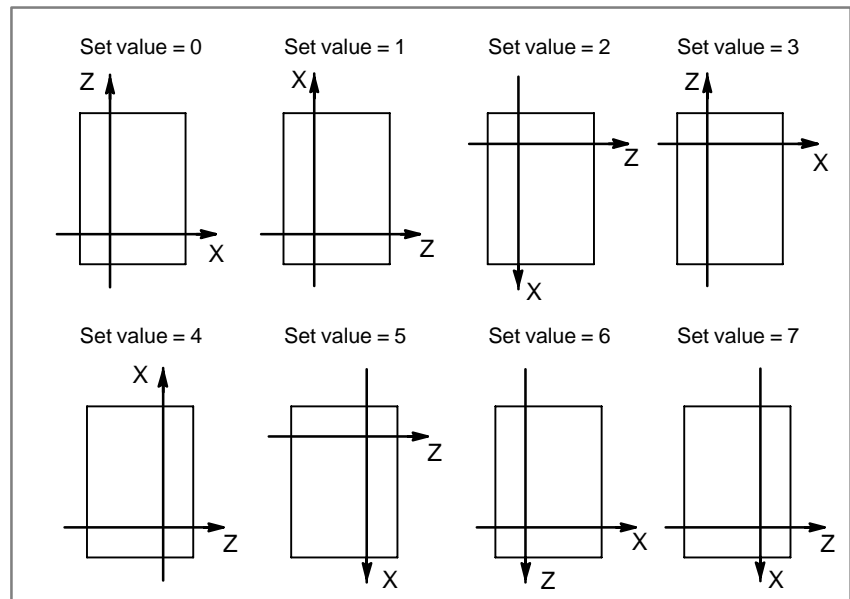

NOTE

This parameter is specified for each path in the two path control. A different drawing coordinate system can be selected for each tool post.

6511	Right margin in solid drawing
6512	Left margin in solid drawing
6513	Upper margin in solid drawing
6514	Lower margin in solid drawing

[Data type] Word

[Unit of data] Dot

These parameters set the drawing margins in pixels on the screen. The unit is a dot.

Parameter No.	Margin area	Standard set value			
		DPO=0		DPO=1	
		7.2"/8.4" LCD	9.5"/10.4" LCD	7.2"/8.4" LCD	9.5"/10.4" LCD
6511	Right	0	0	200	100
6512	Left	0	0	0	0
6513	Upper	25	32	25	32
6514	Lower	0	10	0	10

Set DPO with parameter No. 6500#5.

6515	Change in cross-section position in tri-plane drawing
------	---

[Data type] Byte

[Unit of data] Pixel

[Valid data range] 0 to 10

This parameter sets the change in the cross-section position when a soft key is continuously pressed in tri-plane drawing. When zero is specified, it is assumed to be 1.

8100	#7	#6	#5	#4	#3	#2	#1	#0
	NWP							RST

[Data type] Bit type

RST When the reset key on the MDI panel is pressed:

0 : The reset effects both paths. The reset is effective for both the machining and the background graphics (M series).

1 : The reset key is effective only for the path selected with the path select signal. The reset key cannot be used to stop machining in background graphic mode (M series).

NWP When the background graphic function is being used, this bit must be set to 1.

Note

NOTE

When the dynamic graphics function is used, the graphics function cannot be used. (M series)

Reference item

Series 16i/18i/160i/180i/ 160is/180is	OPERATOR'S MANUAL (For Machining Center) (B-63534EN)	III.12.1	GRAPHICS FUNCTION
		III.12.2	DYNAMIC GRAPHIC DISPLAY
		III.12.3	BACKGROUND GRAPHIC
	OPERATOR'S MANUAL (For Lathe) (B-63524EN)	III.12.1	GRAPHICS FUNCTION
Series 21i/210i/210is	OPERATOR'S MANUAL (For Machining Center) (B-63614EN)	III.12.1	GRAPHICS FUNCTION
		III.12.2	DYNAMIC GRAPHIC DISPLAY
	OPERATOR'S MANUAL (For Lathe) (B-63604EN)	III.12.1	GRAPHICS FUNCTION
Series 20i	OPERATOR'S MANUAL (For Manual Milling Machine) (B-64204EN)	III.14.1	GRAPHICS FUNCTION
		III.14.2	DYNAMIC GRAPHIC DISPLAY
	OPERATOR'S MANUAL (For Manual Lathes) (B-64194EN)	III.14.1	GRAPHICS FUNCTION

12.1.13 Displaying Operating Monitor

- | | |
|--------------------------------------|---|
| General | The load meter can be displayed for each servo axis and the serial spindle. |
| • Display of the servo axes | The load meter can be displayed for up to three servo axes by setting parameters 3151 to 3153. |
| • Display of the spindle axes | When serial spindles are used, the load meter and speedometer can be displayed only for the main serial spindle. |
| • Speedmeter | Although the speedometer normally indicates the speed of the spindle motor, it can also be used to indicate the speed of the spindle by setting bit 6 (OPS) of parameter 3111 to 1. |

Parameter

	#7	#6	#5	#4	#3	#2	#1	#0
3111		OPS	OPM					

[Data type] Bit

OPM Operating monitor

0 : Not displayed

1 : Displayed

OPS The speedmeter on the operating monitor screen indicates:

0 : Spindle motor speed

1 : Spindle speed

3151	Axis number for the first load meter
3152	Axis number for the second load meter
3153	Axis number for the third load meter
3154	Axis number for the 4th load meter
3155	Axis number for the 5th load meter
3156	Axis number for the 6th load meter
3157	Axis number for the 7th load meter
3158	Axis number for the 8th load meter

[Data type] Byte

[Valid data range] 0, 1, . . . , the number of the control axes

Set the numbers of the axes for which measurement values on the load meters for the eight servo motors are displayed. Set the parameters to 0 for those axes for which a load meter need not be displayed.

2086	Rated current parameter (RTCURR)
------	----------------------------------

[Data type] Word axis

4127	Load meter displayed value for maximum output
------	---

[Data type] Word axis

Note

NOTE

The load meter display depends on servo parameter 2086 and spindle parameter 4127. These parameters are set automatically.

Reference item

Series 16i/18i/160i/180i/ 160is/180is	OPERATOR'S MANUAL (For Machining Center) (B-63534EN)	III.11.1.8	Operating Monitor Display
	OPERATOR'S MANUAL (For Lathe) (B-63524EN)	III.11.1.8	Operating Monitor Display
Series 21i/210i/210is	OPERATOR'S MANUAL (For Machining Center) (B-63614EN)	III.11.1.7	Operating Monitor Display
	OPERATOR'S MANUAL (For Lathe) (B-63604EN)	III.11.1.7	Operating Monitor Display
Series 20i	OPERATOR'S MANUAL (For Manual Milling Machine) (B-64204EN)	III.13.1.7	Operating Monitor Display
	OPERATOR'S MANUAL (For Manual Lathes) (B-64194EN)	III.13.1.6	Operating Monitor Display

12.1.14 Stamping the Machining Time

General

The execution time of a program is displayed on the program machine time display screen. The machine time can be displayed, in hours, minutes, and seconds format, for up to 10 main programs.

The time between the first start operation after a reset in memory operation mode, until another reset is performed, is counted. When no reset is performed, the time from the start of operation until M02 (M30) is encountered is counted. The time in a stop state is not counted. The time for completion of an M, S, T, or B function is counted.

The displayed machining time can be inserted (stamped) as a comment in a program stored in memory. The machining time is placed as a comment after the program number.

The machining time located after a program number can be displayed on the program directory screen (by setting bit 0 (NAM) of parameter No. 3107 to 1). Using this screen, the user can determine the machining time required for each program.

Parameter

	#7	#6	#5	#4	#3	#2	#1	#0
3107								NAM

[Data type] Bit

NAM Program list

0 : Only program numbers are displayed.

1 : Program numbers and program names are displayed.

	#7	#6	#5	#4	#3	#2	#1	#0
3404			M02					

[Data type] Bit

M02 When M02 is specified in memory operation

0 : M02 is sent to the machine, and the head of the program is automatically searched for. So, when the end signal FIN is returned and a reset or reset and rewind operation is not performed, the program is executed, starting from the beginning.

1 : M02 is sent to the machine, but the head of the program is not searched for. (The head of the program is searched for by the reset and rewind signal.)

Note**NOTE**

When M02 does not reset the control unit, and completion signal FIN is sent to rewind and execute the program from the beginning (when bit 5 (M02) of parameter No. 3404 is set to 0), machine time is terminated by the completion signal FIN.

Reference item

Series 16i/18i/160i/180i/ 160is/180is	OPERATOR'S MANUAL (For Machining Center) (B-63534EN)	III.11.2.6	Stamping the machining time
	OPERATOR'S MANUAL (For Lathe) (B-63524EN)	III.11.2.6	Stamping the machining time

12.1.15 Software Operator's Panel

General

The software operator's panel function replaces part of the control switches on the machine operator's panel.

The control switches for the functions listed in the following table can be replaced with soft switches. Also available are eight general-purpose soft switches which can be assigned by the machine tool builder. These eight general-purpose soft switches can be optionally named by the machine tool builder. For control switches in groups 1 to 7, parameter (no.7200) can be used to select whether the control switches on the machine operator's panel or soft switches on the MDI of the control unit are used.

Group1 :Mode selection

Group2 :Selection of jog feed axis, manual rapid traverse

Group3 :Selection of manual pulse generator feed axis, selection of manual pulse magnification

Group4 :Jog feedrate override, feedrate override, rapid traverse override

Group5 :Optional block skip, single block, machine lock, dry run

Group6 :Protect key

Group7 :Feed hold

Group8 :General purpose

The states of all soft switches are input to the PMC by output signals. Based on these output signals, the PMC should turn "1" or "0" input signals related to the soft switch functions.

When the soft switch provided for single block operation is turned on, for instance, the control unit does not select the single block operation internally. The single block operation is selected just when the PMC sets the input signal for single block operation to 1.

Signal

Group	Function	Output signal	Related input signal
1	Mode selection	MD1O <F073#0> MD2O <F073#1> MD4O <F073#2> ZRNO <F073#4>	MD1 MD2 MD4 ZRN
2	Jog feed axis select	+J10 – +J40 –J10 – –J40 <F081>	+J1 – +J4 –J1 – –J4
	Manual rapid traverse	RTO <F077#6>	RT
3	Handle feed	HS1AO <F077#0> HS1BO <F077#1> HS1CO <F077#2> HS1DO <F077#3>	HS1A HS1B HS1C HS1D
	Handle feed magnification	MP1O <F076#0> MP2O <F076#1>	MP1 MP2
4	Jog feed rate override	*JV00 – *JV150 <F079, F080>	*JV0 – *JV15
	Feedrate override	*FV00 – *FV70 <F078>	*FV0 – *FV7
	Rapid traverse override	ROV1O <F076#4> ROV2O <F076#5>	ROV1 ROV2
5	Optional block skip	BDTO <F075#2>	BDT
	Single block	SBKO <F075#3>	SBK
	Machine lock	MLKO <F075#4>	MLK
	Dryrun	DRNO <F075#5>	DRN
6	Protect key	KEYO <F075#6>	KEY1 – KEY4
7	Feed hold	SPO <F075#7>	*SP
8	General purpose (Switch from 1st line to the 8th line)	OUT0 – OUT7 <F072>	

Signal address

	#7	#6	#5	#4	#3	#2	#1	#0
F072	OUT7	OUT6	OUT5	OUT4	OUT3	OUT2	OUT1	OUT0
F073				ZRNO		MD4O	MD2O	MD1O
F074								
F075	SPO	KEYO	DRNO	MLKO	SBKO	BDO		
F076			ROV2O	ROV1O			MP2O	MP1O
F077		RTO			HS1DO	HS1CO	HS1BO	HS1AO
F078	*FV7O	*FV6O	*FV5O	*FV4O	*FV3O	*FV2O	*FV1O	*FV0O
F079	*JV7O	*JV6O	*JV5O	*JV4O	*JV3O	*JV2O	*JV1O	*JV0O
F080	*JV15O	*JV14O	*JV13O	*JV12O	*JV11O	*JV10O	*JV9O	*JV8O
F081	-J4O	+J4O	-J3O	+J3O	-J2O	+J2O	-J1O	+J1O

Parameter

	#7	#6	#5	#4	#3	#2	#1	#0
7200		OP7	OP6	OP5	OP4	OP3	OP2	OP1

[Data type] Bit

OP1 Mode selection on software operator's panel

0 : Not operational

1 : Operational

OP2 JOG feed axis select and manual rapid traverse buttons on software operator's panel

0 : Not operational

1 : Operational

OP3 Manual pulse generator's axis select and manual pulse generator's magnification switches on software operator's panel

0 : Not operational

1 : Operational

OP4 JOG feedrate override and rapid traverse override switches on software operator's panel

0 : Not operational

1 : Operational

OP5 Optional block skip, single block, machine lock, and dry run switches on software operator's panel

0 : Not operational

1 : Operational

OP6 Protect key on software operator's panel

0 : Not operational

1 : Operational

OP7 Feed hold on software operator's panel

0 : Not operational

1 : Operational

7210	Jog-movement axis and its direction on software operator's panel "↑"
7211	Jog-movement axis and its direction on software operator's panel "↓"
7212	Jog-movement axis and its direction on software operator's panel "→"
7213	Jog-movement axis and its direction on software operator's panel "←"
7214	Jog-movement axis and its direction on software operator's panel "↖"
7215	Jog-movement axis and its direction on software operator's panel "↗"
7216	Jog-movement axis and its direction on software operator's panel "↘"
7217	Jog-movement axis and its direction on software operator's panel "↙"

[Data type] Byte**[Valid data range]** 0 to 8

On software operator's panel, set a feed axis corresponding to an arrow key on the MDI panel when jog feed is performed.

Set value	Feed axis and direction
0	Not moved
1	First axis, positive direction
2	First axis, negative direction
3	Second axis, positive direction
4	Second axis, negative direction
5	Third axis, positive direction
6	Third axis, negative direction
7	Fourth axis, positive direction
8	Fourth axis, negative direction

Arrow keys on the MDI panel

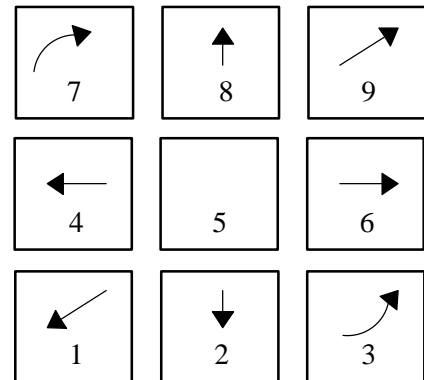

Example

Under X, Y, and Z axis configuration, to set arrow keys to feed the axes in the direction specified as follows, set the parameters to the values given below. [8↑] to the positive direction of the Z axis, [2↓] to the negative direction of the Z axis, [6→] to the positive direction of the X axis [4←] to the negative direction of the X axis, [1↗] to the positive direction of the Y axis, [9↖] to the negative direction of the Y axis

Parameter No. 7210 = 5 (Z axis, positive direction)

Parameter No. 7211 = 6 (Z axis, negative direction)

Parameter No. 7212 = 1 (X axis, positive direction)

Parameter No. 7213 = 2 (X axis, negative direction)

Parameter No. 7214 = 3 (Y axis, positive direction)

Parameter No. 7215 = 4 (Y axis, negative direction)

Parameter No. 7216 = 0 (Not used)

Parameter No. 7217 = 0 (Not used)

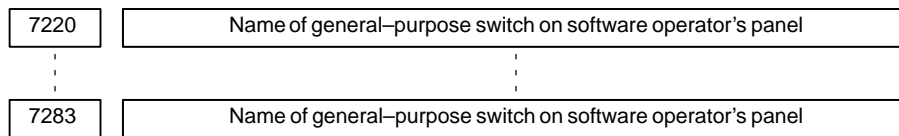

[Data type] Byte

Example

These parameters set the names of the general-purpose switches (SIGNAL 1 through SIGNAL 8) on the software operator's panel.

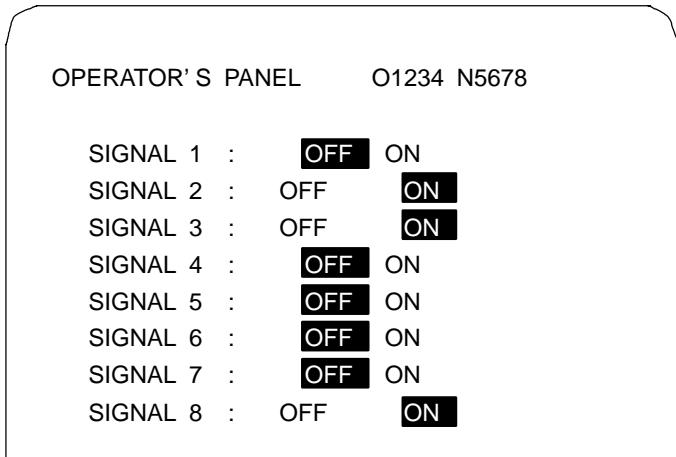

These names are set using character codes that are displayed in parameter Nos. 7220 to 7283.

Parameter No. 7220:

Sets the character code (083) corresponding to S of SIGNAL 1.

Parameter No. 7221:

Sets the character code (073) corresponding to I of SIGNAL 1.

Parameter No. 7222:

Sets the character code (071) corresponding to G of SIGNAL 1.

Parameter No. 7223:

Sets the character code (078) corresponding to N of SIGNAL 1.

Parameter No. 7224:

Sets the character code (065) corresponding to A of SIGNAL 1.

Parameter No. 7225:

Sets the character code (076) corresponding to L of SIGNAL 1.

Parameter No. 7226:

Sets the character code (032) corresponding to (space) of SIGNAL 1.

Parameter No. 7227:

Sets the character code (049) corresponding to 1 of SIGNAL 1.

Parameter Nos. 7228 to 7235:

Set the character codes of SIGNAL 2 shown in the figure above.

Parameter Nos. 7236 to 7243:

Set the character codes of SIGNAL 3 shown in the figure above.

Parameter Nos. 7244 to 7251:

Set the character codes of SIGNAL 4 shown in the figure above.

Parameter Nos. 7252 to 7259:

Set the character codes of SIGNAL 5 shown in the figure above.

Parameter Nos. 7260 to 7267:

Set the character codes of SIGNAL 6 shown in the figure above.

Parameter Nos. 7268 to 7275:

Set the character codes of SIGNAL 7 shown in the figure above.

Parameter Nos. 7276 to 7283:

Set the character codes of SIGNAL 8 shown in the figure above.

The character codes are shown in character code list on the following page.

Character to Code Correspondence Table

Char acter	Code	Com- ment	Char acter	Code	Comment	Char acter	Code	Com- ment	Char acter	Code	Comment
A	065		6	054		ア	177		ム	209	
B	066		7	055		イ	178		メ	210	
C	067		8	056		ウ	179		モ	211	
D	068		9	057		エ	180		ヤ	212	
E	069			032	Space	オ	181		ユ	213	
F	070		!	033	Exclamation mark	カ	182		ヨ	214	
G	071		"	034	Quotation marks	キ	183		ラ	215	
H	072		#	035	Number	ク	184		リ	216	
I	073		\$	036	Dollar mark	ケ	185		ル	217	
J	074		%	037	Percent	コ	186		レ	218	
K	075		&	038	Ampersand	サ	187		ロ	219	
L	076		'	039	Apostrophe	シ	188		ワ	220	
M	077		(040	Left parenthesis	ス	189		ヲ	166	
N	078)	041	Right parenthesis	セ	190		ン	221	
O	079		*	042	Asterisk	ソ	191		ァ	167	
P	080		+	043	Positive sign	タ	192		ィ	168	
Q	081		,	044	Comma	チ	193		ゥ	169	
R	082		-	045	Negative sign	ツ	194		ェ	170	
S	083		.	046	Period	テ	195		ォ	171	
T	084		/	047	Slash	ト	196		ャ	172	
U	085		:	058	Colon	ナ	197		ュ	173	
V	086		;	059	Semicolon	ニ	198		ョ	174	
W	087		<	060	Left angle bracket	ヌ	199		ヅ	175	
X	088		=	061	Equal sign	ネ	200		ヰ	222	Dakuten
Y	089		>	062	Right angle bracket	ノ	201		ォ	223	Han dakuten
Z	090		?	063	Question mark	ハ	202		ッ	161	Full stop
0	048		@	064	Commercial at mark	ヒ	203		〔	162	Left quotation mark
1	049		[091	Left square bracket	フ	204		〕	163	Right quotation mark
2	050		¥	092	Yen mark	ヘ	205		,	164	Comma
3	051]	093	Right square bracket	ホ	206		.	165	Centered dot
4	052		^	094		マ	207			000	Space
5	053		_	095	Underline	ミ	208				

NOTE

The “dakuten” and “han dakuten” in Katakana also correspond to one character.

Note**NOTE**

- 1 Only the modes shown below can be selected by soft switches. When the mode for DNC operation is to be required, then, all control switches for mode selection should be on the machine operator's panel or a general-purpose soft switch should be used to select the mode for DNC operation.

Soft switches available for mode selection

- Manual data input
 - Automatic operation
 - Memory edit
 - Manual handle feed / incremental feed
 - Jog feed
 - Manual reference position return
- 2 Only one soft switch is available for the protection key. But, four input signals are available for protection key (KEY1, KEY2, KEY3 and KEY4). Generally, four input signals are simultaneously turned to "1" or "0" according to the state of the protection soft switch.
 - 3 When the soft switch for feed hold is turned on, output signal SPO is turned to "1", and the PMC turns feed hold signal *SP to "0".

In contrast to the above, when the soft switch for feed hold is turned off, output signal SPO is turned "0" and the PMC turns signal *SP to "1". For soft switches other than feed hold and general soft switches, when an output signal corresponding to a soft switch is turned to "1", the corresponding input signal is turned to "1".

NOTE

4 The following table lists the jog feedrate override values which can be selected by soft switches.

	*JV00 – *JV150 (*JV0 – *JV150)				Override values (%)
	15 ↓	12 ↓	8 ↓	4 ↓	
0	1 1 1 1	1 1 1 1	1 1 1 1	1 1 1 1	0
1	1 1 1 1	1 1 1 1	1 1 1 1	0 1 0 1	0.1
2	1 1 1 1	1 1 1 1	1 1 1 1	0 0 0 1	0.14
3	1 1 1 1	1 1 1 1	1 1 1 0	1 0 1 1	0.2
4	1 1 1 1	1 1 1 1	1 1 1 0	0 1 0 0	0.27
5	1 1 1 1	1 1 1 1	1 1 0 1	1 0 1 0	0.37
6	1 1 1 1	1 1 1 1	1 1 0 0	1 0 1 1	0.52
7	1 1 1 1	1 1 1 1	1 0 1 1	0 1 1 1	0.72
8	1 1 1 1	1 1 1 1	1 0 0 1	1 0 1 1	1.0
9	1 1 1 1	1 1 1 1	0 1 1 1	0 0 1 1	1.4
10	1 1 1 1	1 1 1 1	0 0 1 1	0 1 1 1	2.0
11	1 1 1 1	1 1 1 0	1 1 1 1	0 0 0 1	2.7
12	1 1 1 1	1 1 1 0	1 0 0 0	1 1 0 1	3.7
13	1 1 1 1	1 1 0 1	1 1 1 1	0 1 1 1	5.2
14	1 1 1 1	1 1 0 1	0 0 1 0	1 1 1 1	7.2
15	1 1 1 1	1 1 0 0	0 0 0 1	0 1 1 1	10.0
16	1 1 1 1	1 0 1 0	1 0 0 0	0 1 1 1	14.0
17	1 1 1 1	1 0 0 0	0 0 1 0	1 1 1 1	20.0
18	1 1 1 1	0 1 0 1	0 1 1 1	0 0 1 1	27.0
19	1 1 1 1	0 0 0 1	1 0 0 0	1 0 1 1	37.0
20	1 1 1 0	1 0 1 1	1 0 1 0	1 1 1 1	52.0
21	1 1 1 0	0 0 1 1	1 1 0 1	1 1 1 1	72.0
22	1 1 0 1	1 0 0 0	1 1 1 0	1 1 1 1	100.0
23	1 1 0 0	1 0 0 1	0 1 0 0	1 1 1 1	140.0
24	1 0 1 1	0 0 0 1	1 1 0 1	1 1 1 1	200.0

NOTE

5 The following table lists the feedrate override values which can be selected by soft switches.

	*FV00 – *FV70 (*FV0 – *FV7)			Override values (%)
	7 ↓	4 ↓	0 ↓	
0	1 1 1 1		1 1 1 1	0
1	1 1 1 1		0 1 0 1	10
2	1 1 1 0		1 0 1 1	20
3	1 1 1 0		0 0 0 1	30
4	1 1 0 1		0 1 1 1	40
5	1 1 0 0		1 1 0 1	50
6	1 1 0 0		0 0 1 1	60
7	1 0 1 1		1 0 0 1	70
8	1 0 1 0		1 1 1 1	80
9	1 0 1 0		0 1 0 1	90
10	1 0 0 1		1 0 1 1	100
11	1 0 0 1		0 0 0 1	110
12	1 0 0 0		0 1 1 1	120
13	0 1 1 1		1 1 0 1	130
14	0 1 1 1		0 0 1 1	140
15	0 1 1 0		1 0 0 1	150
16	0 1 0 1		1 1 1 1	160
17	0 1 0 1		0 1 0 1	170
18	0 1 0 0		1 0 1 1	180
19	0 1 0 0		0 0 0 1	190
20	0 0 1 1		0 1 1 1	200

Reference item

Series 16 <i>i</i> /18 <i>i</i> /160 <i>i</i> /180 <i>i</i> / 160 <i>is</i> /180 <i>is</i>	OPERATOR'S MANUAL (For Machining Center) (B-63534EN)	III.11.4.10	Displaying and Setting the Software Operator's Panel
	OPERATOR'S MANUAL (For Lathe) (B-63524EN)	III.11.4.13	Displaying and Setting the Software Operator's Panel
Series 21 <i>i</i> /210 <i>i</i> /210 <i>is</i>	OPERATOR'S MANUAL (For Machining Center) (B-63614EN)	III.11.4.10	Displaying and Setting the Software Operator's Panel
	OPERATOR'S MANUAL (For Lathe) (B-63604EN)	III.11.4.13	Displaying and Setting the Software Operator's Panel
Series 20 <i>i</i>	OPERATOR'S MANUAL (For Manual Milling Ma- chine) (B-64204EN)	III.13.4.7	Displaying and Setting the Software Operator's Panel
	OPERATOR'S MANUAL (For Manual Lathes) (B-64194EN)	III.13.4.8	Displaying and Setting the Software Operator's Panel

12.1.16 Multi-language Display

General

The language displayed on the screen is set by a parameter.

Parameter

	#7	#6	#5	#4	#3	#2	#1	#0
3102		SPN	HNG	ITA	CHI	FRN	GRM	JPN
	DTH	SPN	HNG	ITA	CHI	FRAN	GRM	JPN
	#7	#6	#5	#4	#3	#2	#1	#0
3119							POR	

NOTE

When this parameter has been set, cycle CNC power.

[Data type] Bit

Select the language to be used for the display.

DTH	POR	SPN	HNG	ITA	CHI	FRN	GRM	JPN	Language
0	0	0	0	0	0	0	0	0	English
0	0	0	0	0	0	0	0	1	Japanese
0	0	0	0	0	0	0	1	0	German
0	0	0	0	0	0	1	0	0	French
0	0	0	0	0	1	0	0	0	Chinese
0	0	0	0	1	0	0	0	0	Italian
0	0	0	1	0	0	0	0	0	Korean
0	0	1	0	0	0	0	0	0	Spanish
0	1	0	0	0	0	0	0	0	Portuguese
1	0	0	0	0	0	0	0	0	Dutch

12.1.17 Remote Diagnosis

General

With the remote diagnosis function, a commercial PC can be connected, as a service terminal, to the CNC via an RS-232-C interface or a telephone line and used to monitor the status of the CNC and to change data in it by means of menu-driven remote diagnosis terminal software (Windows application).

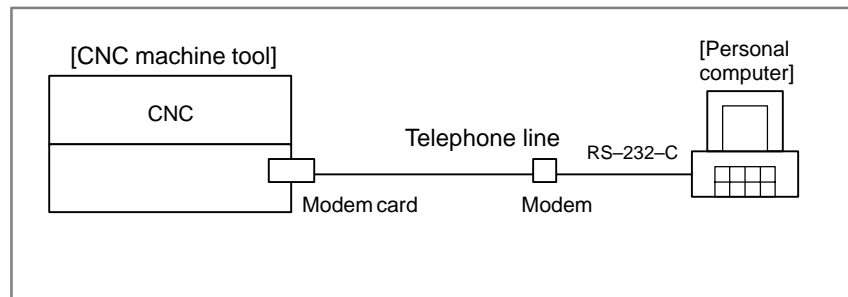

The remote diagnosis terminal software is sold separately.

The remote diagnosis function provides the following capabilities:

a. CNC programs

a-1 Computer → CNC

- (1) CNC command data for verification
- (2) Searching for a specified program
- (3) Part program
- (4) Deleting a specified program
- (5) Deleting all programs

a-2 CNC → computer

- (1) Part program
- (2) Displaying a program directory
- (3) Program number of a program being executed
- (4) Sequence number of a sequence being executed

b. Computer → CNC

- (1) Parameter
- (2) Pitch error data
- (3) Tool offset value
- (4) Custom macro variable
- (5) Selecting a display screen
- (6) Memory contents
- (7) PMC data
- (8) Displaying a specified message
- (9) All parameters

- c. CNC → computer
 - (1) Alarm information
 - (2) Machine position
 - (3) Absolute position
 - (4) Skip position
 - (5) Servo delay
 - (6) Acceleration/deceleration delay
 - (7) Diagnosis
 - (8) Parameter
 - (9) Tool life management data
 - (10) Display screen status
 - (11) Modal information
 - (12) Pitch error data
 - (13) Tool offset value
 - (14) Custom macro variable
 - (15) Memory contents
 - (16) Ladder program
 - (17) Actual feedrate
 - (18) Status
 - (19) A/D conversion data
 - (20) PMC data
 - (21) Screen character data
 - (22) Printed circuit board information
 - (23) Ladder title
 - (24) Series and edition of PMC/ladder
 - (25) All parameters
- d. File function selection
 - (1) Listing files
 - (2) Referencing a file
 - (3) Deleting a file
 - (4) Copying a file
 - (5) Renaming a file
 - (6) Linking a file
 - (7) Changing the current directory
 - (8) Creating a directory
 - (9) Deleting a directory

NOTE

An arrow “→” indicates the direction of data flow.

12.1.18 External Operator Message Logging and Display

General

Parameter setting enables one external operator message (consisting of up to 255 characters) or, simultaneously, up to 4 external operator message (consisting of up to 63 characters) to be displayed.

External operator messages can be logged in a history file.

These messages can be displayed on the external operator message history screen.

Parameter

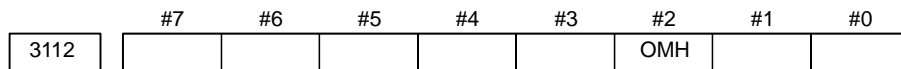

[Data type] Bit

OMH The external operator message history screen is:

0 : Not displayed.

1 : Displayed.

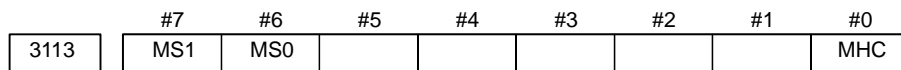

MHC External operator message history data:

0 : Cannot be cleared.

1 : Can be cleared.

(Such data can be cleared using the [CLEAR] soft key.)

MS0, MS1 Set the number of items and the item length.

MS1	MS0	Number of history data characters	Number of history data items
0	0	255	8
0	1	200	10
1	0	100	18
1	1	50	32

CAUTION

When the values of MS0 and MS1 are changed, all preserved external operator message history data is cleared.

	#7	#6	#5	#4	#3	#2	#1	#0
3207								OM4

[Data type] Bit

- OM4** A message displayed on the external operator message screen can have:
- 0 : Up to 256 characters, and just a single message can be displayed.
 - 1 : Up to 64 characters, and up to four messages can be displayed.

Reference item

Series 16i/18i/160i/180i/ 160is/180is	OPERATOR'S MANUAL (For Machining Center) (B-63534EN)	III.11.7.1	External operator message logging and display
	OPERATOR'S MANUAL (For Lathe) (B-63524EN)	III.11.7.1	External operator message logging and display
Series 21i/210i/210is	OPERATOR'S MANUAL (For Machining Center) (B-63614EN)	III.11.7.1	External operator message logging and display
	OPERATOR'S MANUAL (For Lathe) (B-63604EN)	III.11.7.1	External operator message logging and display
Series 20i	OPERATOR'S MANUAL (For Manual Milling Machine) (B-64204EN)	III.13.7.1	External operator message logging and display
	OPERATOR'S MANUAL (For Manual Lathes) (B-64194EN)	III.13.7.1	External operator message logging and display

12.1.19



Erase Screen Display/Automatic Erase Screen Display

General

Displaying the same characters in the same positions on the screen causes a LCD to degrade relatively quickly. To help prevent this, the screen can be cleared by pressing specific keys. It is also possible to specify the automatic clearing of the screen if no keys are pressed during a period specified by a parameter. However, it is disabled for the open CNC.

Erase screen display

Holding down the  key and pressing a function key clears the screen.

Hold down the  key and press a function key (such as  and ).

Press a function key, to restore the display.

Automatic erase screen display

The CNC screen is automatically cleared if no keys are pressed during the period (in minutes) specified by parameter (No. 3123). The screen is restored by pressing any key.

- **Clearing the screen with automatic erase screen display**

The CNC screen is cleared once the period (minutes) specified with parameter No. 3123 has elapsed, provided the following conditions are satisfied:

Conditions for clearing the CNC screen

- Automatic erase screen display cancel signal *CRTOF is “0”.
- Parameter No. 3123 is non-zero.
- None of the following keys have been pressed:
 - MDI keys
 - Soft keys
 - External input keys
- No alarm has been issued.

- **Restoring the screen with automatic erase screen display**

A cleared CNC screen is restored once at least one of the following conditions is satisfied:

Conditions for restoring the CNC screen

- Automatic erase screen display cancel signal *CRTOF is “1”.
- Any of the following keys has been pressed:
 - MDI keys
 - Soft keys
 - External input keys
- An alarm has been issued.

- **Automatic erase screen display cancel signal** Automatic erase screen display cancel signal *CRTOF (G062#1) is valid only for path 1. This signal is invalid for the signals of path 2 (G1062#1) and those of the loader (G062#1).
- **Clearing the screen using CAN + function key** If parameter No. 3123 is set to 0, clearing of the screen using the CAN key and a function key is disabled.
- **Specified period** The period specified with parameter No. 3123 is valid only for path 1.
- **Alarm for another path** The screen is not cleared if an alarm is issued for path 1 or 2 or the loader before the specified period elapses.

WARNING
 Pressing any key while the screen is being cleared restores the screen. Do not press the DELETE, INSERT, or ALTER key to restore the screen.

Signal

Automatic erase screen display cancel signal *CRTOF <G062#1>

- [Classification] Input signal
- [Function] Enables or disables the automatic screen erase function. This signal is used to switch the control mode.
- [Operation] When this signal is set to 0, the control unit:
 - Enables the automatic screen erase function.
 When this signal is set to 1, the control unit:
 - Disables the automatic screen erase function, displays the screen, and initializes the timer.
 This signal is valid only for path 1.

Signal address

	#7	#6	#5	#4	#3	#2	#1	#0
G062							*CRTOF	

Parameter

3123	Screen display timeout
------	------------------------

[Data type] Bytes

[Unit of data] Minutes

[Valid data range] 1 to 255

This parameter specifies the period that must elapse before erase screen display is applied. If 0 is set, the screen is not cleared.

Limitation

For the Series 160*i*/180*i*/210*i*/160*is*/180*is*/210*is*, this function can not be used.

Reference item

Series 16 <i>i</i> /18 <i>i</i> /160 <i>i</i> /180 <i>i</i> / 160 <i>is</i> /180 <i>is</i>	OPERATOR'S MANUAL (For Machining Center) (B-63534EN)	III.11.8	Cleaning the screen
	OPERATOR'S MANUAL (For Lathe) (B-63524EN)	III.11.8	Cleaning the screen
Series 21 <i>i</i> /210 <i>i</i> /210 <i>is</i>	OPERATOR'S MANUAL (For Machining Center) (B-63614EN)	III.11.8	Cleaning the screen
	OPERATOR'S MANUAL (For Lathe) (B-63604EN)	III.11.8	Cleaning the screen
Series 20 <i>i</i>	OPERATOR'S MANUAL (For Manual Milling Machine) (B-64204EN)	III.13.8	Cleaning the screen
	OPERATOR'S MANUAL (For Manual Lathes) (B-64194EN)	III.13.8	Cleaning the screen

12.1.20 Touch Panel

General

A touch panel can be used on the LCD display, as follows:

- (1) The soft keys (F0 to F9, FR, and FL) in the lower section on the 10.4-inch color LCD/MDI panel are changed to those for the touch panel.
- (2) Touch panel operation substitutes for cursor control on the 10.4-inch color LCD.
- (3) A touch panel can be used to create C executor-based applications such as touch panel-based software versions of a machine operator's panel and a calculator.

Hardware connection

The CNC uses RS-232C serial port 2 (JD36B) on the motherboard to connect the touch panel.

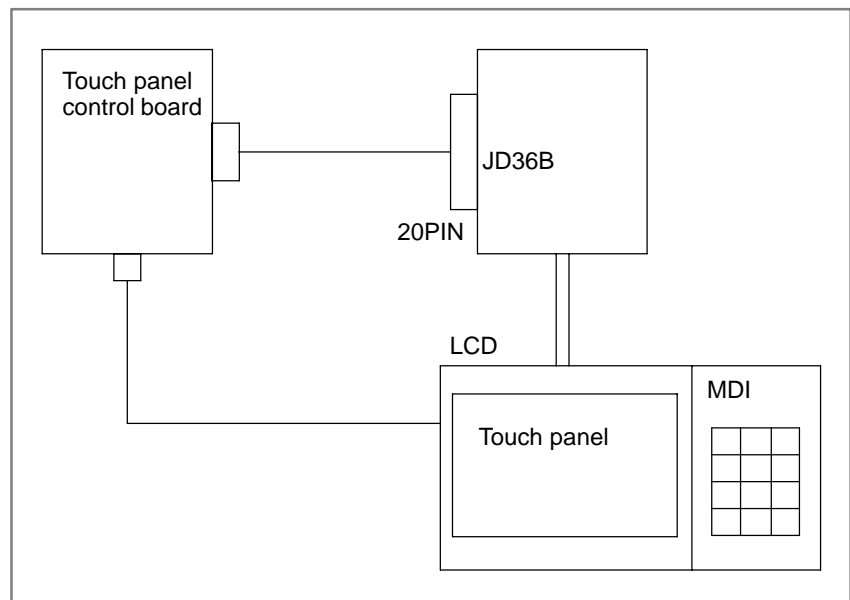

Hardware characteristics

The hardware characteristics of the touch panel are described below.

When a point on the touch panel is pressed, the touch panel controller sends the coordinates of the point to the CNC via an RS-232C interface.

(1) Coordinate system

1) Initial coordinate system

The upper left corner of the input area of the touch panel is set as the origin ($X = 0$, $Y = 0$) of the coordinate system. The maximum coordinates of the lower right corner is (640, 480).

2) Coordinate system after compensation

The coordinate system can be subjected to compensation, so initial origin and maximum coordinates can be maintained.

(2) Data sampling interval

The coordinates of a point on the touch panel are output via an RS-232C interface. The information is received at sampling intervals of 50 ms.





(3) Positional precision

A positional precision of ± 2.5 mm can be maintained by performing 9-point compensation as described later.

Software key control

When a rectangular soft key button on the screen is pressed, the soft key button display is indented. This type of a soft key behaves in the same manner as conventional soft keys. In addition, the touch panel soft keys can be customized using the C executor.

Cursor control

When the cursor is displayed, pressing the desired point on the screen causes the cursor to move to that point, in the same way as with the , , , and  cursor keys.

C executor

Touch panel-based application programs can be created using the C executor.

Refer to the C Executor Programming Manual (B-62443EN-3) for details of the C executor.

Calibration

(1) Functions

Calibration functions as follows:

- 1) Specifies an effective input area.
- 2) Specifies maximum coordinates.
- 3) Corrects linearly.
- 4) Makes the panel input position match the LCD display position.

(2) Execution time



Calibration must be executed when:

- 1) A new touch panel is installed.
- 2) An existing touch panel is replaced.
- 3) Memory (SRAM) is cleared to all 0s.

(3) Cautions

- 1) If an alarm condition occurs during calibration, the alarm screen appears when the calibration screen is exited.
- 2) Calibration can be made regardless of what the current mode is.
- 3) Once the system gets started, calibration should be made promptly before actual operations begin.

(4) Procedure

- 1 Enable touch panel calibration by setting parameter DCL (bit 5 of parameter No. 3113) to 1.
- 2 Press the  function key.
- 3 Press the rightmost soft key,  (next menu page key) three times.

- 4 Press the [TP CAL] soft key.
The following touch panel calibration screen appears.

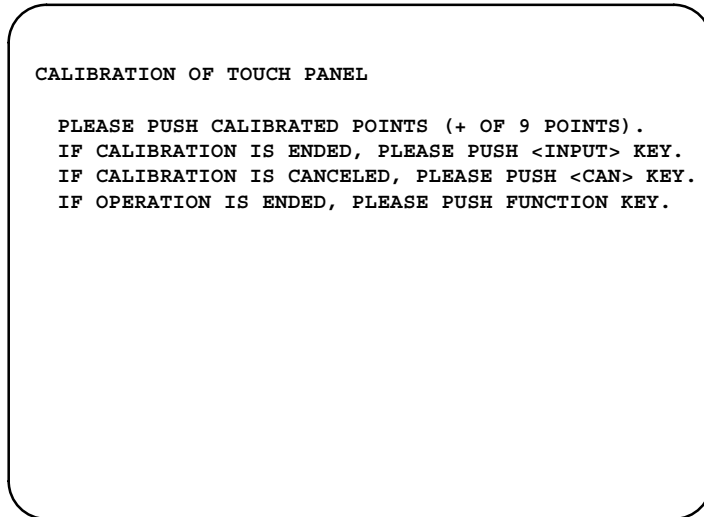

- 5 Press the nine calibration points using the dedicated pen. When a point is pressed exactly, the corresponding “+” display starts blinking. If a point off a “+” display is pressed, the message [CALIBRATED POINT DOES NOT MATCH. PLEASE PUSH AGAIN.] appears.
- 6 After pressing the nine calibration points, press the to complete calibration. To discontinue or rerun calibration, press the key.
- 7 When calibration ends normally, the message [CALIBRATION WAS ENDED.] appears.
- 8 Pressing another function key causes you to exit the calibration screen.
- 9 Once calibration was completed, disable touch panel calibration by resetting parameter DCL (bit 5 of parameter No. 3113) to 0.

Parameter

	#7	#6	#5	#4	#3	#2	#1	#0
3113			DCL					

[Data type] Bit

DCL Specifies whether to enable calibration for the touch panel.
0 : Disabled.
1 : Enabled.

	#7	#6	#5	#4	#3	#2	#1	#0
3119						DDS		

[Data type] Bit

DDS Specifies whether to enable touch panel operation.

- 0 : Enabled.
1 : Disabled.

As described in “Hardware connection,” the touch panel is connected to the RS-232-C serial port 2 (JD36B) on the CNC motherboard. When the touch panel is used, serial port 2 (JD36B) is set up for touch panel operation, regardless of an I/O channel (input/output unit selection) set up in parameter Nos. 20, 21, 22, and 23. Use JD36A for other input/output units.

The existing settings of parameter Nos. 100, and 121 to 123 are disabled for channel 2 (JD36B), and fixed as follows:

- Baud rate: 9600 bps
- Stop bit: 1 bit
- Parity check: None

If no touch panel is used, parameter DDS (bit 2 of parameter No. 3119) must be set to 1.

Alarm and message

Number	Message	Description
085	COMMUNICATION ERROR	A communication error occurred during touch panel initialization. It is likely that the touch panel is not connected correctly or is defective. After correcting the cause of the error, cycle the power. This alarm message is used also for errors in existing input/output units. If a conventional input/output unit is connected to RS-232C serial port 1 (JD5A), this alarm message may be displayed because of an error on serial port 1.

Caution

CAUTION

- 1 The touch panel soft keys cannot be used after memory (SRAM) is cleared to all 0s. In this case, it is necessary to use the MDI (cursor and page keys) for setup.
- 2 After the power is switched on, do not use the touch panel until a power-on reset sequence is completed. Otherwise, a P/S alarm (No. 085) indicating a communication error.
- 3 If more than one point on the touch panel is pressed simultaneously, it is assumed that only one point that represents a gravity position determined according to the way each point is pressed, is pressed. Be sure to press only one point at a time.

12.1.21 External Touch Panel Interface

General

Support of the external touch panel interface allows an SNP-X protocol compliant external touch panel to be connected to the FANUC Series 16i/18i/21i (referred to just as the CNC hereinafter).

External touch panels are similar to the machine operator's panel. By using an external touch panel, the user can read and write the signals controlled by the PMC (input signals (X), output signals (Y), internal relays (R), keep relays (K), data tables (D), timers (T), and counters (C)).

The external touch panel features a plotting capability. The user can perform plotting and address (signal) assignment freely. For example, when a screen with data table settings assigned is created, data can be set in the data table by using switches on the screen.

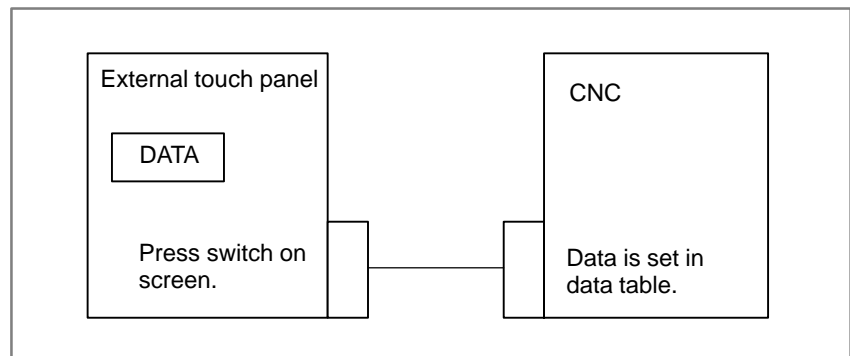

Function details

- **Connection**

The customer needs to prepare the cable for connecting the RS-232C serial port 2 (JD36B) of the main CPU board of the CNC and the SIO connector of the external touch panel.

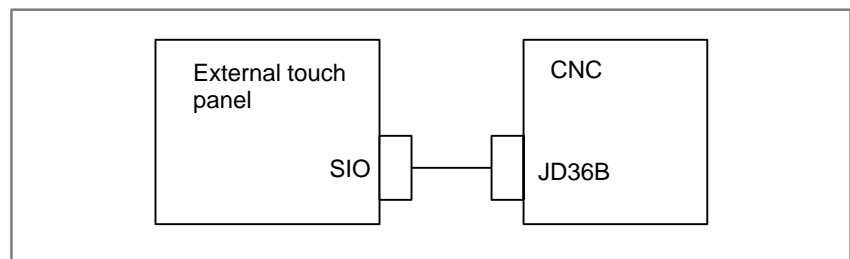

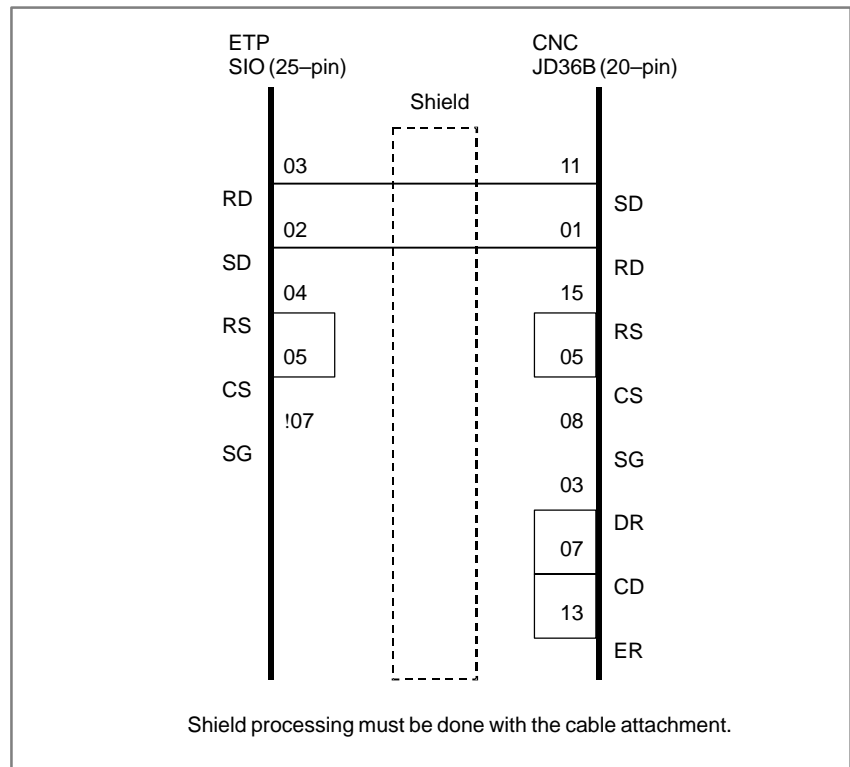

- **Power-on sequence**
- **CNC data that can be read from and written to the external touch panel**

Turn the power to the external touch panel on before the CNC power-on.

Data at the CNC addresses listed below can be read into and written from the external touch panel. The address range varies depending on the PMC model.

- Input address: X0000 to X0127 (read only)
X1000 to X1063 (read only)
- Output address: Y0000 to Y0127
Y1000 to Y1063
- Internal relay: R0000 to R1499
- Keep relay: K0000 to K0019
- Data table: D0000 to D2999
- Timer: T0000 to T0079
- Counter: C0000 to C0079

When the FS21*i* and PMC-SA1 are used, data at the following addresses can be read into and written from the external touch panel:

- Input address: X0000 to X0127 (read only)
X1000 to X1063 (read only)
- Output address: Y0000 to Y0127
Y1000 to Y1063
- Internal relay: R0000 to R0999
- Keep relay: K0000 to K0019
- Data table: D0000 to D1859
- Timer: T0000 to T0079
- Counter: C0000 to C0079

● **Protocol**

The CNC uses SNP-X protocol direct commands only. So, as the protocol on the external touch panel (ETP) side, also use SNP-X protocol direct commands only.

The processing in response to a request for writing 3-byte or longer data is the same as the processing in response to a request for writing 2-byte or shorter data. For details of the SNP-X protocol (such as device code specifications), refer to "SNP-X Protocol Document".

● **Caution**

(1) The external touch panel interface and the function of enabling DMA transfer for RS-232C transmission of the C executor (bit 3 (DMA) of parameter No. 8650) cannot be used at the same time.

(2) The external touch panel and the touch panel on the *i* series LCD cannot be used at the same time.

● **Supplement**

It has been verified that the following touch panels manufactured by Digital Corporation can be connected with the external touch panel interface:

- GP-450E
- GP-550T
- GP-550S

Parameter

	#7	#6	#5	#4	#3	#2	#1	#0
3119					TPD			

[Data type] Bit

TPD Connection of an external touch panel is:

0 : Enabled.

1 : Disabled.

CAUTION

As described in "Connection" in "Function details" above, RS-232C serial port 2 (JD36B) of the main CPU board of the CNC is used for ETP connection.

When using an external touch panel, set bit 3 (TPLDS) of parameter No. 3119 to 0. Then, the JD36B can be used specifically for the external touch panel regardless of the existing I/O channel setting (I/O device selection) in parameter No. 20 (including Nos. 21 to 23). For other I/O device connection, use another port such as the JD36A.

When TPLDS is set as described above, the existing settings in parameter Nos. 100 and 121 to 123 are ignored for channel 2 (JD36B), and the following settings are assumed:

- Baud rate: 19200 bps
- Stop bit: 1 bit
- Parity check: Even parity



12.1.22 Periodic Maintenance Screen

General

The periodic maintenance screen shows the current statuses of those items that require periodic replacement (backup battery, LCD backlight, touch panel, etc.). An item whose service life has expired is indicated by the machine run time.

When the service life of at least one of the set consumables has expired, a signal can be output to the PMC.

Screen displays and settings

- 1 Press the  function key.
- 2 Press the  next menu page key several times until the [MAINTE] soft key appears.
- 3 Press the [MAINTE] soft key. The periodic maintenance screen appears.

The periodic maintenance screen consists of two pages: status screen and setup screen, either of which can be selected using the [CHANGE] soft key.

• Status screen displays and settings

On the status screen, it is possible to register up to 10 maintenance items. The remaining lifetime and count status for each registered item are displayed on the screen.

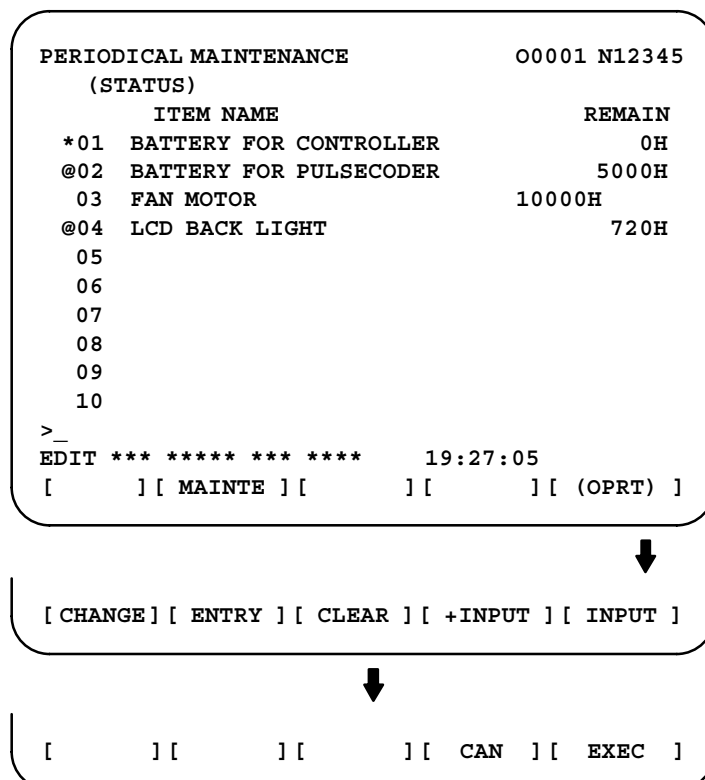

(1) Maintenance item names

The names of maintenance items are set up here. They can be registered using either the corresponding menu or MDI keys.

1) Menu-based setup

- 1 To display the setting menu, place the cursor on the desired item, and press the [ENTRY] soft key. There are two types of setup menus: machine maintenance menu and CNC maintenance menu.
- 2 Pressing the [MACHIN] or [NC] soft key displays a menu that contains typical machine or CNC model names.
- 3 Place the cursor on the desired item and press the [SELECT] soft key. Now press the [EXEC] soft key to return to the status screen where the selected item name is set up.
- 4 Pressing the [CAN] soft key restores the previous screen.
- 5 Pressing the [MAINTE] soft key displays the status screen.

On the machine maintenance screen, items can be registered according to the procedure below.

(a) Program-based registration

An item can be registered by executing a program in the following format.

Format**G10 L61 Px [n]**

x : Registration number

n : Item name
[Alphanumeric character]

NOTE

For the CNC edit function, specific strings of two or more characters are registered as reserved words of custom macro commands.

(Example: GO for GOTO, WH for WHILE, and SI for SIN)

Therefore, when a program to register item names is created in the above format using the CNC edit function, input strings may be converted to the reserved words of custom macro commands. Thus, desired strings may not be input.

(Example: When SIGNAL is input, it is converted to SINGNAL.)

When the string to be displayed as an item number cannot be input with the CNC edit function, set the string by editing the data output from the periodic maintenance screen on the PC, and then loading the data through the periodic maintenance screen, as described in "Inputting/outputting registered data" later in this section (12.1.22 Periodic maintenance screen).

For the reserved words of the custom macro commands, refer to "Editing Custom Macros" in Operator's Manual.

(b) MDI-based registration

An item name can be registered by first keying in data in the following format, then pressing the [INPUT]. In addition, pressing the [+INPUT] soft key can modify an existing item.

Format

Alphanumeric-character*two-byte-character*
alphanumeric-character

Two-byte character codes conform to the FUNUC codes.

To key in a two-byte character code, key in an asterisk (*) before and after the character code.

Up to 24 characters can be registered as an item name when it consists of only alphanumeric characters, while up to 12 characters can be registered when it consists of only two-byte characters.

Example) To register "LCD backlight"

>LCD*110E10F410CC114010B610FE_

NOTE

- 1 The asterisk (*) is used as a control code, so it cannot be used in the item name. Likewise, square brackets “[” and “]” and parentheses “(” and “)” must be excluded from the item name.
EOB “;” must be executed from the item name.
- 2 If a null item is selected on the machine maintenance screen, the warning message “EDIT REJECTED” will appear. If a null item name is selected on the NC maintenance screen, a blank will be set up.
- 3 When a blank item is selected on a screen of the machine, a warning “Unable to edit” is issued.
When a blank item is selected on a screen of the NC, a blank is set.

To delete a registered item name, place the cursor on it, and press the [CLEAR] soft key, then the [EXEC] soft key.

[Machine maintenance screen]

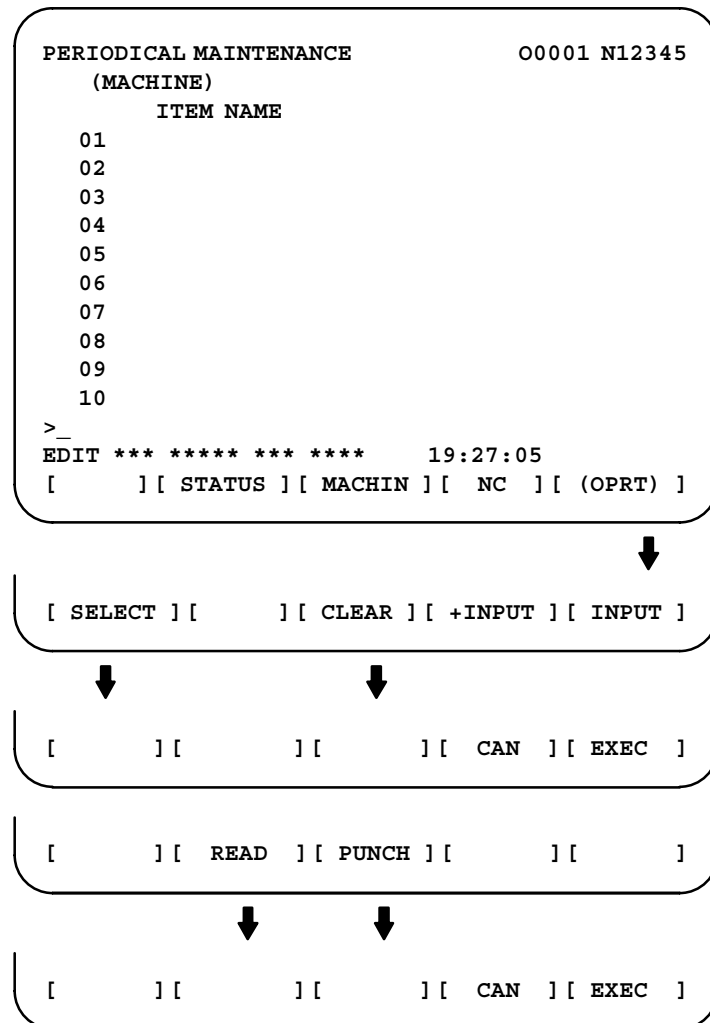

[CNC maintenance screen]

```

PERIODICAL MAINTENANCE          00001 N12345
(NC)
  ITEM NAME
01 BATTERY FOR CONTROLLER
02 BATTERY FOR PULSECODER
03 FAN MOTOR
04 LCD BACK LIGHT
05
06
07
08
09
10
>_
EDIT *** ***** *** ***** 19:27:05
[      ] [ STATUS ] [ MACHIN ] [ NC ] [ (OPRT) ]

↓

[ SELECT ] [      ] [      ] [      ] [      ]

↓

[      ] [      ] [      ] [ CAN ] [ EXEC ]

```

NOTE

On the CNC maintenance screen, it is impossible to register, delete, input, and output item.

2) MDI-based setup

An item can be registered by first keying in data in the following format, then pressing the [INPUT] soft key or MDI key. In addition, pressing the [+INPUT] soft key can modify an existing item name.

NOTE

The asterisk (*) is used as a control code, so it cannot be used in the item name. EOB ";" must be executed from the item name. Likewise, square brackets "[" and "]" and parentheses "(" and ")" must be excluded from the item name.

To delete a registered item, place the cursor on it, and press the [CLEAR] soft key, then the [EXEC] soft key.
When an item is deleted, the related service life, remaining lifetime, and count type are also deleted.

(2) Remaining lifetime

The remaining lifetime of an item is the time allowed before it must be replaced. It is displayed in a count-down format. When the remaining lifetime becomes less than the percentage specified in parameter No. 8911 of the corresponding service life, the remaining lifetime display turns red. Count-down continues even after the service life has expired.

NOTE

No setup can be made on the status screen. Setup is possible only on the setting screen.

(3) Count status

The count status of each item is displayed at the left of the corresponding item number as listed below:

Display	Count status
Blank	Counting is at a halt.
@	Counting is under way.
*	Service life has expired.

● **Setting screen displays and settings**

On the setting screen, it is possible to specify the service life, remaining lifetime, and count type for each registered item. It also displays the same count status as displayed on the status screen.

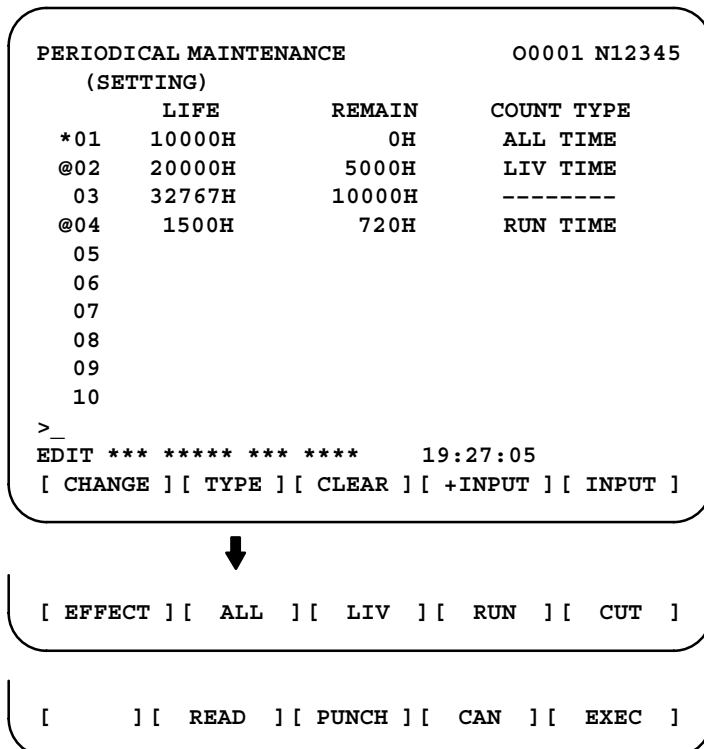

(1) Service life

To specify the service life, key in the corresponding data and press [INPUT] soft key or MDI key. The same data is set up as both the service life and remaining lifetime. In addition, the count type is indicated as: “_____”

Pressing the [+INPUT] soft key causes newly entered data to be added to the existing service life and the remaining lifetime.

The valid data range for this item is: 0 to 65535 (hours)

NOTE

- 1 If an attempt is made to enter data for a null item name, the warning message “EDIT REJECTED” appears.
- 2 If an attempt is made to enter data that does not fall into the valid data range, the warning message “DATA IS OUT OF RANGE” appears.
- 3 If an attempt is made to enter data that would set the service life or remaining lifetime below 0, it will be set to 0.
- 4 If the [CLEAR] or [TYPE] soft key is pressed, the warning message “EDIT REJECTED” appears.

(2) Remaining lifetime

The remaining lifetime of an item is the time allowed before it must be replaced. It is displayed in a count-down format. When the remaining lifetime becomes less than the percentage specified in parameter No. 8911 of the corresponding service life, the remaining lifetime display turns red. Count-down continues even after the service life has expired.

To specify the remaining lifetime, key in the corresponding data and press [INPUT] soft key or MDI key.

Pressing the [+INPUT] soft key causes newly entered data to be added to the current remaining lifetime.

The valid data range for this item is: 0 to the corresponding service life
Pressing the [CLEAR] soft key, then the [EXEC] soft key causes the remaining lifetime to be set with the same value as the service life.

NOTE

- 1 If an attempt is made to enter data for a null item, the warning message “EDIT REJECTED” appears.
- 2 If an attempt is made to enter data that does not fall into the valid data range, the warning message “DATA IS OUT OF RANGE” appears.
- 3 If an attempt is made to enter data that would set the remaining lifetime below 0, it will be set to 0.
- 4 If the [TYPE] soft key is pressed, the warning message “EDIT REJECTED” appears.

(3) Count type

Pressing the [TYPE] causes the following count types to be displayed as soft keys. Select the desired one and press the [EXEC] soft key to set it up.

Software	Meaning	Display
[EFFECT]	No counting takes place (the counter is halted).	---
[ALL-AX]	Counting continues unconditionally (nonstop counting).	ALL
[LIV]	Counting continues as long as the power is on.	LIV
[RUN]	Counting continues during run time.	RUN
[CUT]	Counting continues during cutting time.	CUT

NOTE

- 1 If an attempt is made to enter data for a null item, the warning message "EDIT REJECTED" appears.
- 2 The [INPUT] and [+INPUT] soft keys do not function for count type.
- 3 Leap year is not a counted for in the counting, and can cause a 24-hour error in the counting.

Inputting and outputting the registered data

The registered data related to the maintenance service life can be output to an external unit, using the [PUNCH] soft key. Similarly, data can be input from an external unit, using the [READ] soft key. These input/output operations can be performed on the status, setting, and menu (machine maintenance only) screens.

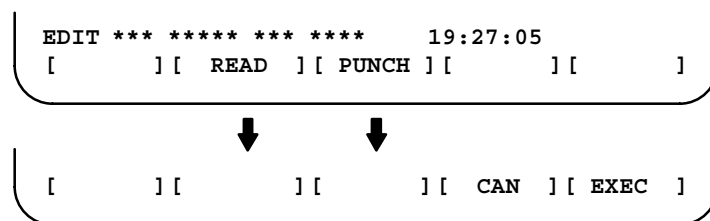

• **Data output**

In EDIT mode, pressing the [PUNCH] soft key causes registered data to be output in the following formats.

- Status and setting screens

Format

```
G10 L60 P01 Aa Rr [n] Qq ;
G10 L60 P02 Aa Rr [n] Qq ;
G10 L60 P03 Aa Rr [n] Qq ;
:
```

- Menu screen (machine maintenance only)

Format

G10 L61 P01 [n] ;
G10 L61 P02 [n] ;
G10 L61 P03 [n] ;
 :

a : Service life

r : Remaining lifetime

n : Item name

[Alphanumeric character]

q : Count type

0 = No counting.

1 = Nonstop counting.

2 = Counting continues as long as the power is on.

3 = Counting continues throughout run time.

4 = Counting continues throughout cutting time.

• Data input

In EDIT mode, pressing the [READ] soft key causes input data to be registered according to a specified format (G10). Registration is possible even if the format (G10) is already in program memory as long as the programmable data input option is available.

NOTE

Registration may not be performed correctly unless the input format (G10) matches the output format.

Parameter

8911	Lifetime versus service life percentage
------	---

[Data type] Byte

[Unit of data] 1%

[Valid data range] 0 to 100

On the periodic maintenance screen, the remaining lifetime display turns red for warning purposes, if the remaining lifetime goes below a specified percentage of the corresponding service life.

Signal

Output signal indicating the expiration of the service life managed by periodic maintenance
LIFOVR <F093#0>

[Classification] Output signal

[Function] Notifies the PMC that the service life of at least one of items managed on the periodic maintenance screen is expired.

[Operation] This signal is set to 1 when the status of the service life of at least one of items managed on the periodic maintenance screen is expired. This signal is set to 0 by resetting all items whose service life status is expired on the periodic maintenance screen.

[Remark] This signal is valid when an item for which to perform maintenance management is set on the periodic maintenance screen.

Signal address

	#7	#6	#5	#4	#3	#2	#1	#0
F093								LIFOVR

12.1.23 Fine Torque Sensing

General

This function is a monitor function for providing detailed disturbance load torque data. The CNC stores disturbance load torque data detected by servo and spindle motors in internal memory. The following operations are possible on stored torque data:

- Reference stored torque data from the PMC through the window function.
- Calculate the average, maximum, and distribution of stored torque data (statistical calculation), and read these values through the window function.
- Plot and display a graph of stored torque data on the torque monitor screen.
- Set the detection level of the abnormal load detection alarm on the torque monitor screen. (The abnormal load detection function is optional.)
- Save stored torque data as sample data for later data comparison.
- Save stored torque data on a memory card.

This function is optional.

Function details

Storing disturbance load torque data

While the torque sensing command signal is held 1, the CNC stores disturbance load torque data detected by servo and spindle motors in internal memory. As the target axes, up to four axes can be specified in parameter Nos. 6360 to 6363. When a servo motor is specified as a target axis, bit 0 of servo parameter No. 2016 must be set to 1.

The sampling time of external disturbance torque data for a servo motor is 1 ms, and that for a spindle motor is 2 ms. The CNC stores the average of sampled data at intervals of the period (8, 16, or 32 ms) specified as the store interval in bits 0 and 1 of parameter No. 6350.

When the store interval is set to 16 ms, for example, the CNC stores the average of the most recent 16 data items (servo motors) or eight data items (spindle motors) every 16 ms.

When the sample data store function is enabled (bit 2 of parameter No. 6350 is set to 1), stored torque data can be stored as sample data. The original torque data of sample data is called as the latest data.

The period during which data can be stored varies depending on the number of target axes for storage and the store interval as follows:

Store interval Number of target axes	Every 8 ms	Every 16 ms	Every 32 ms
1 axis	Approx. 69.9 min	Approx. 139.8 min	Approx. 279.6 min
2 axes	Approx. 35.5 min	Approx. 69.9 min	Approx. 139.8 min
3 or 4 axes	Approx. 17.4 min	Approx. 35.5 min	Approx. 69.9 min

NOTE

- 1 When the sample data store function is enabled (bit 2 of parameter No. 6350 is set to 1), the period during which data can be stored is halved.
- 2 When the above period is exceeded, no more data is stored even if the torque sensing command signal is 1.
- 3 Once the power is turned off, stored torque data is erased. When you want to maintain stored torque data even after the power is turned off, save the data as sample data, or save the data on the memory card.
- 4 When the torque sensing command signal is set to 0, store operation is interrupted. When the signal is set to 1 again, store operation restarts to store torque data following the torque data stored before the interruption. To restart store operation from the beginning, input the store counter clear signal.
- 5 Because of the difference in interface, even when servo motor data and spindle motor data are stored as data collected at the same point of time, these data items are strictly not at the same point of time.

Statistical calculation of disturbance load torque data

At the same time when storing disturbance load torque data, the CNC calculates the maximum value of the disturbance load torque data. When calculating the maximum value, the CNC uses the absolute value of the average data of most recent eight data items (for a servo motor) or four data items (for a spindle motor) collected every 8 ms regardless of the store interval.

When the statistical calculation start signal is set to 1, the CNC obtains the average and distribution of stored disturbance load torque data. While the torque sensing command signal is 1, or when statistical calculation has already been done, the CNC does not perform this calculation.

Torque monitor screen

A graph of stored torque data can be plotted on the torque monitor screen. On the torque monitor screen, you can also save data as sample data, output latest data to the memory card, and set a detection level.

This screen can be used only when bit 7 of parameter No. 3119 is set to 0 (VGA type display).

Display method

1. Press the <SYSTEM> function key.
2. Press the [>] soft key several times.
3. Press the [TRQ-MN] soft key.

Displayed items

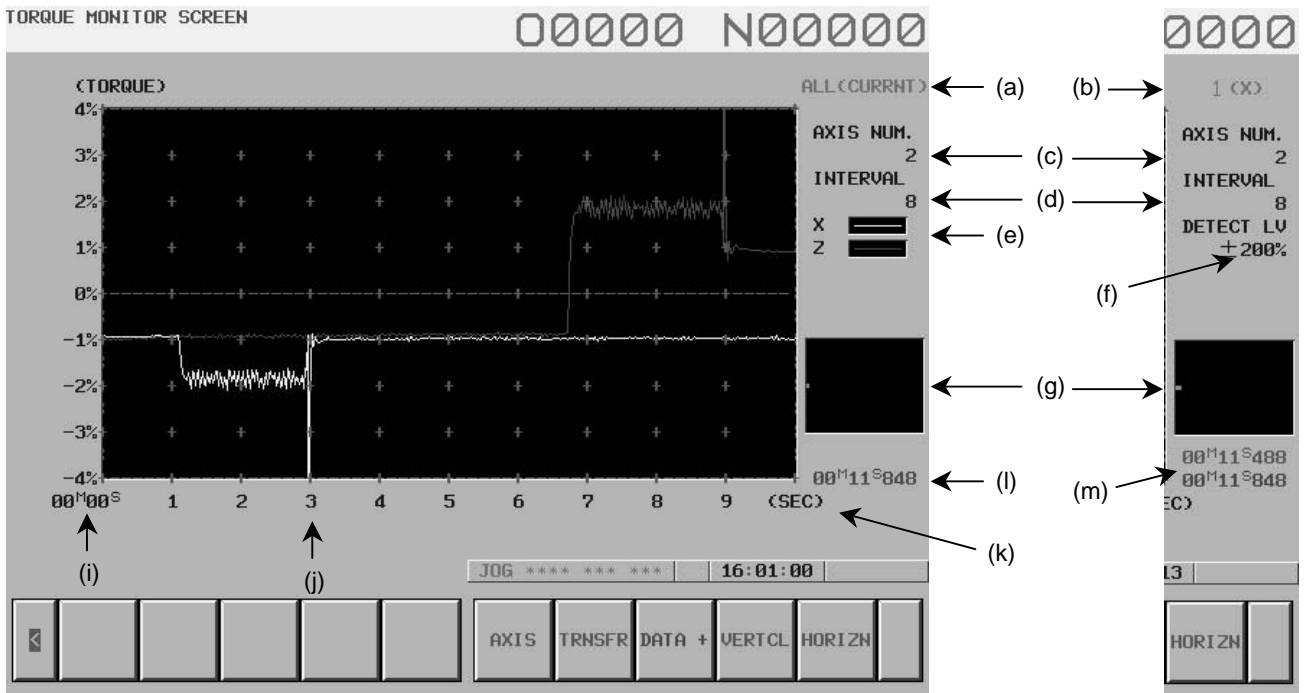

All-axes display

Single-axis display

- (a) Whether the displayed data is the current data or sample data is indicated (only in all-axes display mode).
- (b) The axis number and name of the target axis are indicated (only in single-axis display mode).
- (c) The number of valid axes for store operation is indicated.
- (d) The store interval is indicated in ms.
- (e) The display colors of the axes in the graph are indicated (only in all-axes display mode).
- (f) The detection level is indicated (only in single-axis display mode). In the graph, the detection level is indicated with a red horizontal line.
- (g) The position of the currently displayed range in the whole is indicated. When the scale of the vertical or horizontal axis is being changed, that condition is indicated.
- (h) The scale of the torque ratio (the vertical axis) is indicated.
- (i) The time at the graph start point since the start of store operation is indicated.
- (j) The time from the graph start point is indicated.
- (k) The unit of the time from the graph start point is indicated.
- (l) When the latest data is indicated, the total time from the start of store operation until the end of store operation is indicated. (When store operation is currently continued, the total time until the current time is indicated.) When sample data is displayed, the total time required to store sample data is indicated (only in all-axes display mode).

- (m) When the current torque data is indicated, the total time from the start of store operation until the end of store operation is indicated. (When store operation is currently continued, the total time until the current time is indicated). When the sample data save function is enabled (bit 2 of parameter No. 6350 is set to 1), the total time since the start of store operation for the sample data is also indicated.

Operation

- **Selecting an axis to be displayed (selecting all axes, the first axis, second axis, third axis, or fourth axis)**

When there are two or more target axes for fine torque sensing, you can select a target axis for data display.

Press the [(OPRT)] and [AXIS] soft keys, and select a desired axis from [ALL-AX], [1ST], [2ND], [3RD], and [4TH]. When [ALL-AX] is selected, data on all the target axes is displayed. When single-axis display is selected, and the sample data save function is enabled (bit 2 of parameter No. 6350 is set to 1), sample data and latest data are displayed at the same time.

- **Selecting displayed data (only in all-axes display mode; selection between latest data and sample data)**

When all-axes display is selected, and the sample data save function is enabled (bit 2 of parameter No. 6350 is set to 1), the displayed data can be switched between the sample data and latest data. Press the [(OPRT)] soft key, then press [DATA+].

- **Changing the detection level (only in single-axis display mode)**

When single-axis display is selected, you can change the detection level. In the graph, the detection level is displayed with a red horizontal line. Press the [(OPRT)] then [DETECT] soft keys. To increase the detection level, press [+1%] or [+10%]. To decrease the detection level, press [-1%] or [-10%]. To end changing the detection level, press [END].

When the detection level is matched with the threshold value of the abnormal load detection alarm (bit 4 of parameter No. 6350 is set to 1), pressing [END] reflects the detection level in parameter No. 2104 (for servo motors) or No. 4341 (for spindle motors). (Abnormal load detection is a separate option.)

- **Changing the torque ratio (the vertical axis) (magnification, reduction, and display position)**

You can magnify and reduce the torque ratio (the vertical axis) and can change its display position. Press the [(OPRT)] then [VERTCL]. Each time you press [EXPANS], the torque ratio per graduation changes from 1%, 2.5%, 5%, 10%, 25%, 50%, 1%, ... Pressing [REDUCT] changes the torque ratio in the opposite direction. To change the display position of the graph, press [↑] or [↓]. Pressing [SET] terminates torque ratio change operation, displaying the graph with a specified ratio at a specified position.

- **Changing time (the horizontal axis) (magnification, reduction, and display position)**

You can magnify and reduce the time axis (the horizontal axis) and can change its display position. Press the [(OPRT)] then [HORIZN]. Each time you click [EXPANS], time per graduation is changed from 32 ms, 64 ms, 128 ms, 0.25 sec, 0.5 sec, 1 sec, 2.5 sec, 5 sec, 10 sec, 1 min, 2.5 min, 5 min, 10 min, 15 min, 0.5 h, 32 ms, ... Pressing [REDUCT] changes time in the opposite direction. To change the display position of the graph, press [←] or [→]. Pressing [SET] terminates time change operation, displaying the graph with specified time at a specified position.

- **Saving data to the memory card and loading data from the memory card**

You can save data to the memory card and load data from the memory card. Press the [(OPRT)] then [TRNSFR] soft keys. To save data, press [SAVE] then [EXEC]. Data is saved under the file name "FNTRQSNS.DAT" on the memory card. To load data, press [LOAD] then [EXEC]. "FNTRQSNS.DAT" on the memory card is loaded. If the memory card status differs from the current status (the number of target axes, store interval, and sample data save function enabled or disabled state), an error is indicated without loading data. It takes about one minute to save or load data. During loading, do not turn off the power. To stop save or load operation halfway, press the [STOP] soft key.

- **Saving the latest data as sample data (only when the sample data save function is enabled)**

When the sample data save function is enabled (bit 2 of parameter No. 6350 is set to 1), the latest data can be saved as sample data. The data saved as sample data is not erased even after the power is turned off. Press the [(OPRT)] then [TRNSFR] soft keys, then press the [COPY] then [EXEC] soft keys. It takes approximately 20 seconds to copy data. Do not turn off the power during copy operation.

Soft key operation

(1) Displaying a single axis

[] [AXIS] [TRNSFR] [DETECT] [VERTCL] [HORIZN] []
	↓		↓		↓		↓		↓	
	(2)		(7)		(3)		(4)		(5)	

(1)' Single axis (the number of target axis: 1)

[] [] [TRNSFR] [DETECT] [VERTCL] [HORIZN] []
	↓		↓		↓		↓		↓	
			(7)		(3)		(4)		(5)	

(2) Selecting the axes to be displayed

[] [ALL] [1ST] [2ND] [3RD] [4TH] []
	↓		↓		↓		↓		↓	
	(6)		(1)		(1)		(1)		(1)	

(3) Changing the detection level

[] [END] [-1%] [-10%] [+1%] [+10%] []
	↓		↓		↓		↓		↓	
	(1), (6)									

(4) Changing the vertical axis

[] [SET] [↓] [↑] [REDUCT] [EXPANS] []
	↓		↓		↓		↓		↓	
	(1), (6)									

(5) Changing the horizontal axis

[] [SET] [←] [→] [REDUCT] [EXPANS] []
	↓		↓		↓		↓		↓	
	(1), (6)									

(6) Displaying all axes

[] [AXIS] [TRNSFR] [DATA+] [VERTCL] [HORIZN] []
	↓		↓		↓		↓		↓	
	(2)		(7)				(4)		(5)	

(7) Save, load, and copy

[] [SAVE] [LOAD] [] [COPY] [CANCEL] []
	↓		↓		↓		↓		↓	
	(8)		(8)				(9)		(1), (6)	

(8) Confirmation



(9) Confirmation



- **Fine torque sensing parameter screen**
- **Display method**
- **Displayed items**

Parameters related to the fine torque sensing function can be set on the fine torque sensing parameter setting screen. This screen can be used only when bit 7 of parameter No. 3119 is set to 0 (VGA type display).

1. Press the <SYSTEM> function key.
2. Press the [>] soft key several times.
3. Press the [TRQ-ST] soft key.

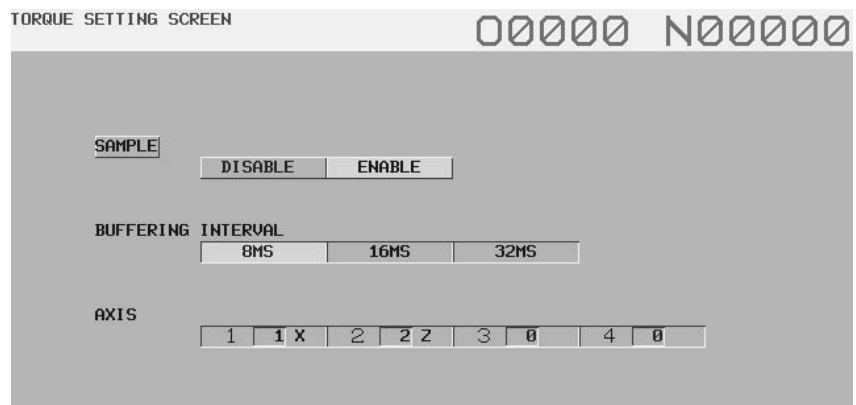

In each item, the current setting is indicated with red characters.

- (a) indicates whether the sample data save function is disabled or enabled. When the setting is changed, the item is enclosed with a yellow frame.
- (b) indicates the store interval. When the setting is changed, the item is enclosed with a yellow frame.
- (c) indicates the controlled-axis number of each target axis. When the setting is changed, it is displayed with black characters.

- **Operation**

1. Use the up and down cursor keys <↑> and <↓> to select the item you want to change among the sample, buffering interval, and axis.
2. When selecting the sample or store interval item, use the right and left cursor keys <←> and <→> to make a selection. When selecting the axis item, position the cursor to a desired axis number by using the right and left cursor keys, and enter a controlled-axis number by using numeric keys.
3. Pressing the [SET] soft key reflects the change result in actual parameters.
4. When you want to cancel the change, press the [CANCEL] soft key. Then, the previous setting is restored. The change of a setting, however, cannot be canceled after the [SET] soft key is pressed.

Signal

Torque sensing command signal FTCMD <G203#0>

[Classification] Input signal

[Function] Stores disturbance load torque data in CNC memory.

[Operation] While the torque sensing command signal is 1, the CNC stores disturbance load torque data in memory. Changing the signal state from 1 to 0 stops store operation. When the signal is set to 1 again, store operation resumes. To newly start store operation, input the store counter clear signal.

Statistical calculation start signal FTCAL <G203#1>

[Classification] Input signal

[Function] Calculates the distribution and average of disturbance load torque data.

[Operation] When the statistical calculation start signal is set to 1, the CNC calculates the distribution and average of stored disturbance load torque data.

Store counter clear signal FTCLR <G203#2>

[Classification] Input signal

[Function] Clears the store counter.

[Operation] When the store counter clear signal is set to 1, the CNC clears the counter used for store operation. The subsequent store operation starts from the beginning of memory.

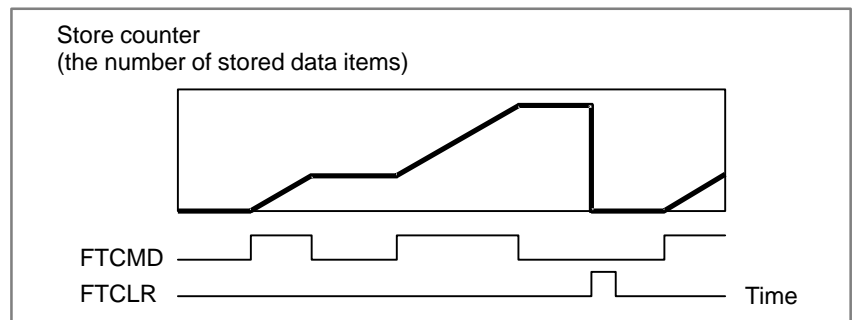

Signal address

	#7	#6	#5	#4	#3	#2	#1	#0
G203						FTCLR	FTCAL	FTCMD

Parameter

	#7	#6	#5	#4	#3	#2	#1	#0
6350				FTA		FTM	TQ2	TQ1

[Data type] Bit**TQ1, TQ2** The store interval for the fine torque sensing function is set.

TQ1	TQ2	Store interval
0	0	8ms
0	1	16ms
1	0	32ms
1	1	Invalid (P/S5199)

FTM The function of saving stored disturbance load torque data as sample data is:

0 : Disabled.

1 : Enabled.

FTA This bit specifies whether to match the detection level on the torque monitor screen with the threshold value of the abnormal load detection alarm (parameter No. 2104 or 4341).

0 : The detection level is not matched with the threshold.

1 : The detection level is matched with the threshold.

When this bit is set to 1, pressing the [END] soft key after changing the detection level on the torque monitor screen reflects the detection level in parameter No. 2104 (servo motors) or No. 4341 (spindle motors). (The abnormal load detection function is optional.)

NOTE

Even when the setting of parameter No. 2104 or 4341 is changed by MDI or other means, the detection level on the torque monitor screen remains unchanged.

6360	Target axis 1 for fine torque sensing
6361	Target axis 2 for fine torque sensing
6362	Target axis 3 for fine torque sensing
6363	Target axis 4 for fine torque sensing

[Data type] Byte**[Valid data range]** -4 to 8

These parameters specify target axes for the fine torque sensing function. For a servo axis, specify a controlled-axis number from 1 to the number of controlled axes. For a spindle axis, specify an axis number from -1 to -(the number of controlled axes), where the sign of the axis number is inverted. If an illegal axis number is set, the P/S5199 alarm is issued.

NOTE

If the number of target axes is N, use target axes 1 to N. If 0 is set for target axis M, the target axis (M + 1) and subsequent target axes are ignored.

[Example]	Parameter	Setting
	Target axis 1	1
	Target axis 2	2
	Target axis 3	0
	Target axis 4	3

When the parameters are set as shown above, only the first and second axes are regarded as the target axes for sensing, and the third axis is not regarded as a target axis.

NOTE

When servo axes are specified as target axes, bit 0 of parameter No. 2016 for the target controlled axes must be set to 1. When this parameter is set to 0 for any one of the target axes, store operation does not started for any axis even if the torque sensing command signal is input.

Alarm and message

Number	Message	Description
5199	FINE TORQUE SENSING PARAMETER	An error is found in a parameter related to the fine torque sensing function. Correct the parameter. <ul style="list-style-type: none"> The store interval is invalid. An invalid axis number is set as a target axis.

Window function

With the window function, stored torque data and statistical calculation results can be referenced from the PMC.

Referencing the store counter

The number of stored torque data items is referenced.

- Input data

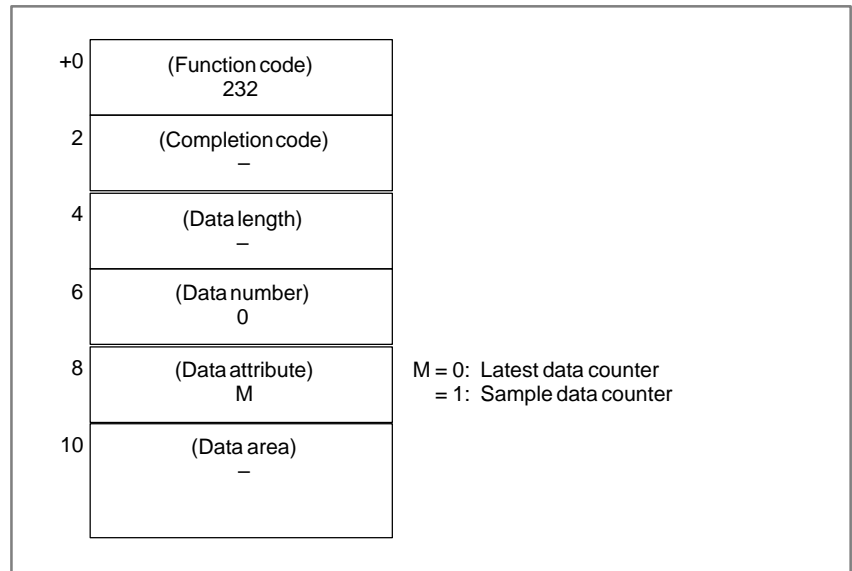

- Output data

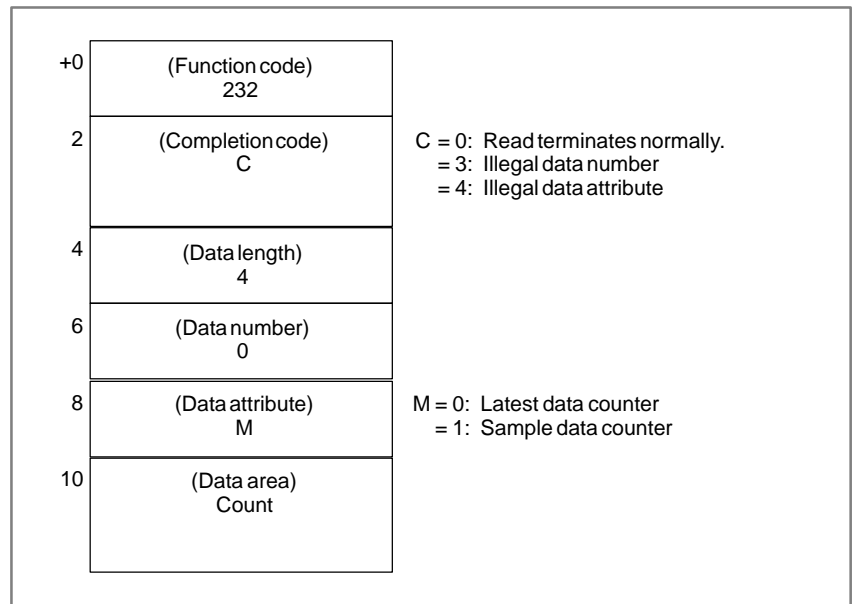

Referencing stored torque data (reading most recent data)

Among stored torque data, the most recently stored data is referenced.

- Input data

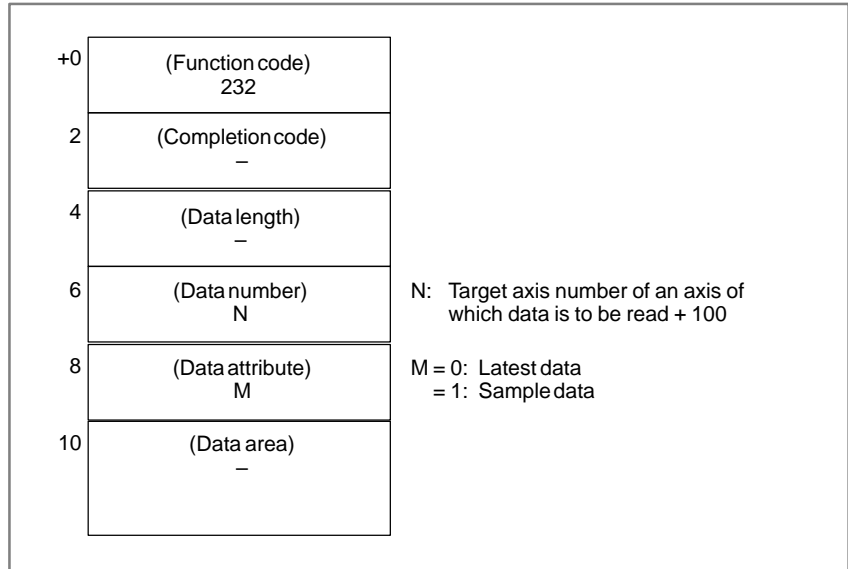

Example: Read the most recently stored data of the latest data for the axis with target axis number 2.

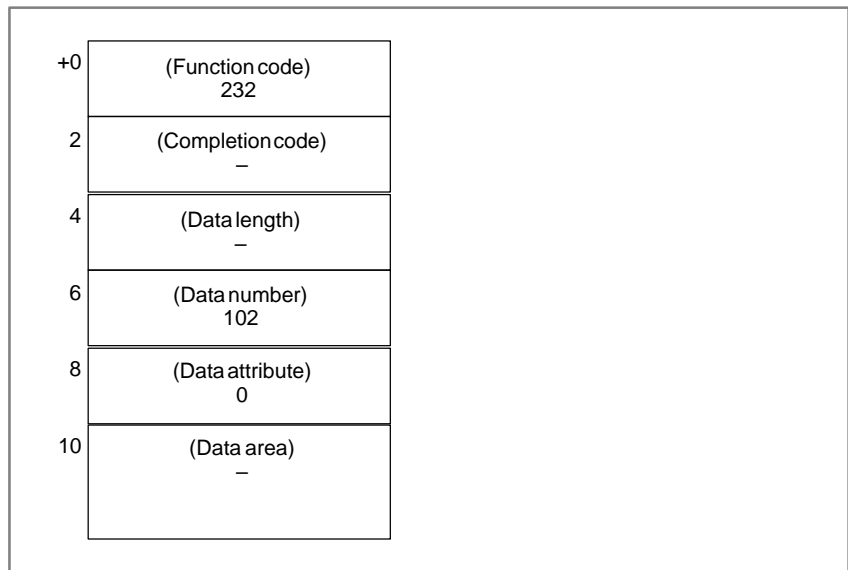

- Output data

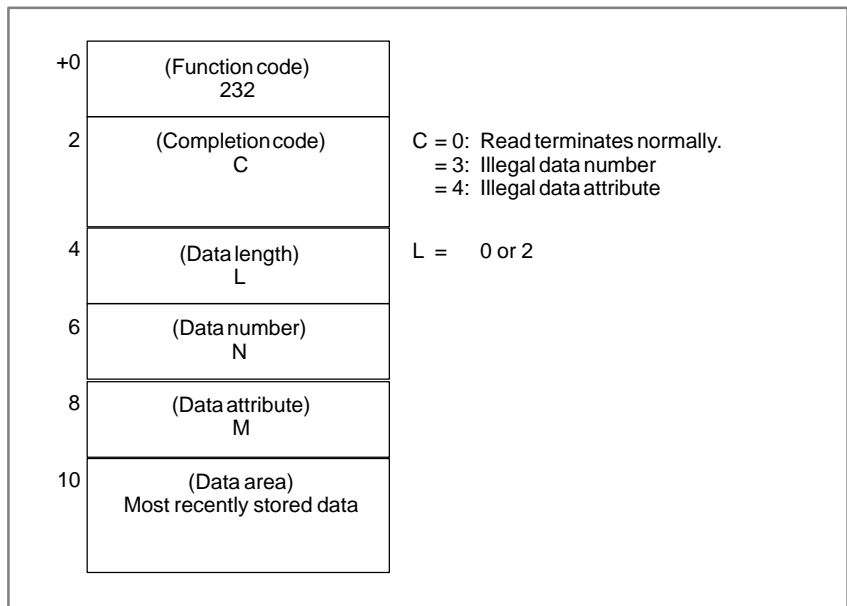
**NOTE**

- 1 If no data is stored, no data is output, and read operation terminates normally with L set to 0.
- 2 When sample data is selected as the data attribute, sample data corresponding to the most recently stored data of the latest data is output.
Example: Suppose that 10000 sample data items (data numbers 0 to 9999) and 5000 latest data items (data numbers 0 to 4999) are stored. If data attribute M is set to 0, the latest data with data number 4999 is output. If M is set to 1, sample data with data number 4999 is output.
- 3 When sample data is selected as the data attribute, and there is no sample data corresponding to the most recently stored data of the latest data, no data is output, and read operation terminates normally with L set to 0.
Example: Suppose that 5000 sample data items (data numbers 0 to 4999) and 10000 latest data items (data numbers 0 to 9999) are stored. If data attribute M is set to 1, no data is output, and read operation terminates normally with L set to 0.

Referencing stored torque data (reading arbitrary data)

Among stored torque data, arbitrary data is referenced.

- Input data

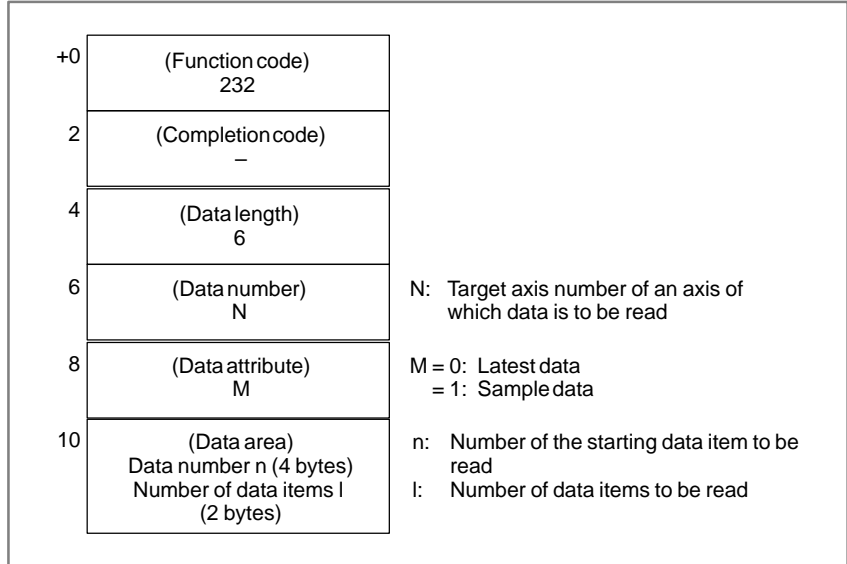

The valid range of the data number n is as follows:

$$0 \leq n \leq (524288 \times \frac{1}{a} \times \frac{1}{b}) - 1$$

where, a= {
 The number of target axes is 1.
 The number of target axes is 2.
 The number of target axes is 3 or 4.

b= {
 The sample data save function is disabled.
 The sample data save function is enabled.

The valid range of the number of data items l is as follows:

$$1 \leq l \leq 120$$

Example: Read 120 sample data items starting with the 12345th data item for the axis with target axis number 2.

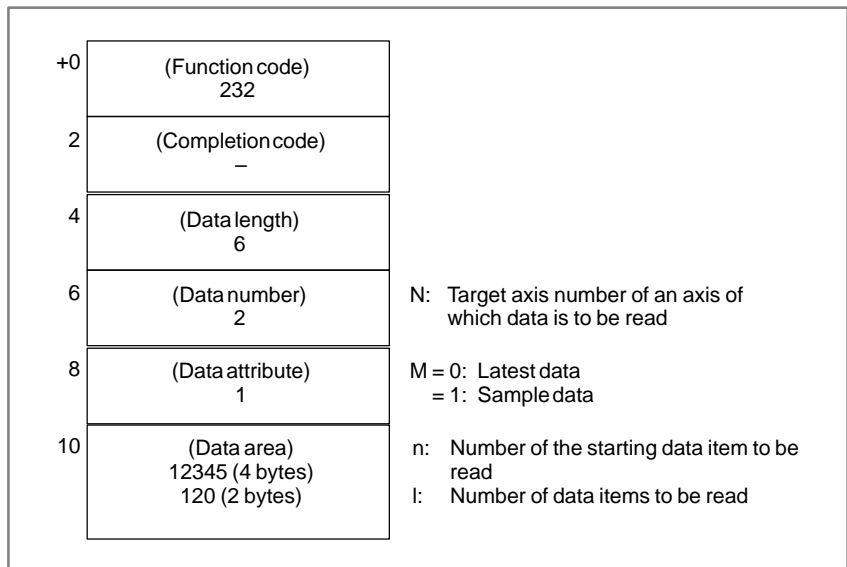

● Output data

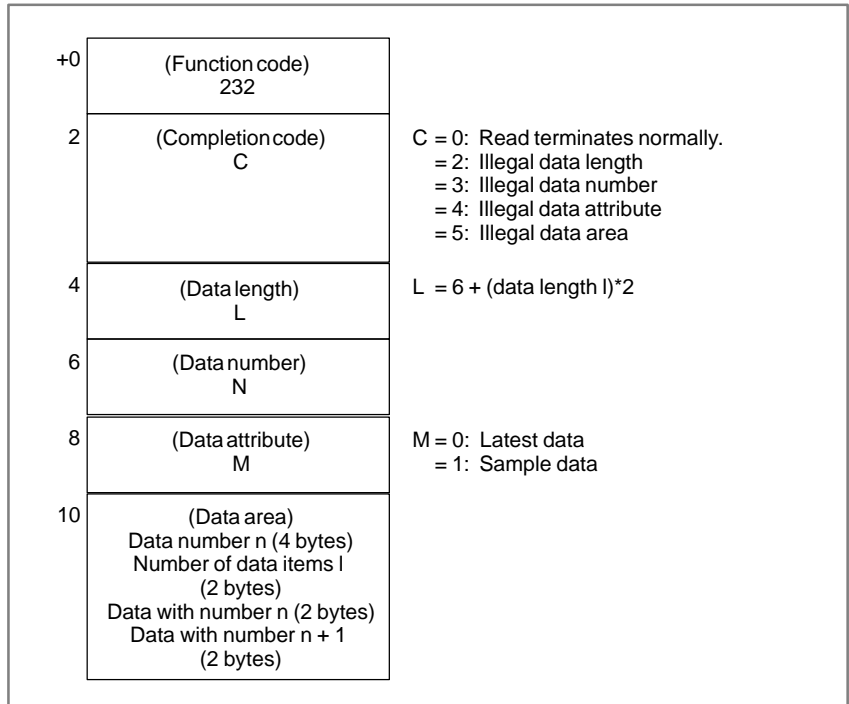

NOTE

- 1 If data number n is within the valid range, but it is beyond the number of data items actually stored, no data is output, and read operation terminates with the number of data items l set to 0.

Example: When the data number n is within the number of actually stored data items, and $(n + l - 1)$ exceeds the number of actually stored data items, just the stored data is output, and read operation terminates normally. In this case, the number of data items l is changed to the number of the output data items.

- 2 Suppose that the number of target axes is 2, and the sample data save function is enabled (bit 2 of parameter No. 6350 is set to 1). Data numbers ranging from 0 to 131071 are then valid. When 131000 data items are actually stored (data numbers 0 to 130999), and an attempt is made to read data starting from the data item having data number $n = 131020$ ((1) in the figure below), no data is output, and the number of data items l is set to 0.

Example: Suppose that under the same conditions as explained in the above example, an attempt is made to read 120 data items (l) starting from a data item having the data number 130900 (n) ((2) in the figure below). Then, data items with data numbers 130900 to 130999 are output, and the number of data items l is set to 100. Also, when n is 130990 and l is 120 under the same conditions ((3) in the figure below), data items with data numbers 130990 to 130999 are output, and l is set to 10.

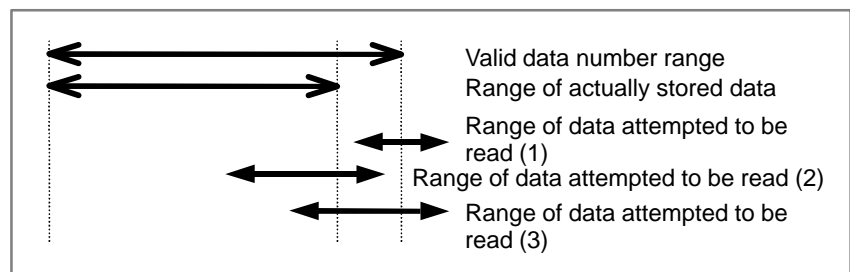

Referencing statistical calculation results

● Input data

+0	(Function code) 226	
2	(Completion code) -	
4	(Data length) -	
6	(Data number) N	N = -1 : Read for all axes = 1 to 4 : Read for an axis (specified with a target axis number)
8	(Data attribute) -	
10	(Data area) -	

NOTE

For read for an axis, only the axes specified in parameter Nos. 6360 to 6363 are specifiable.

● Output data
(For read for all axes)

+0	(Function code) 226	
2	(Completion code) C	C = 0: Read operation terminates normally. = 3: Illegal data number
4	(Data length) L	L = 6 to 24
6	(Data number) -	
8	(Data attribute) -	
10	Average for target axis 1	Data is output for the axes set in parameter Nos. 6360 to 6363.
12	Maximum for target axis 1	
14	Distribution for target axis 1	
16	Average for target axis 2	
18	Maximum for target axis 2	
20	Distribution for target axis 2	
32	... Distribution for target axis 4	

(Read for an axis)

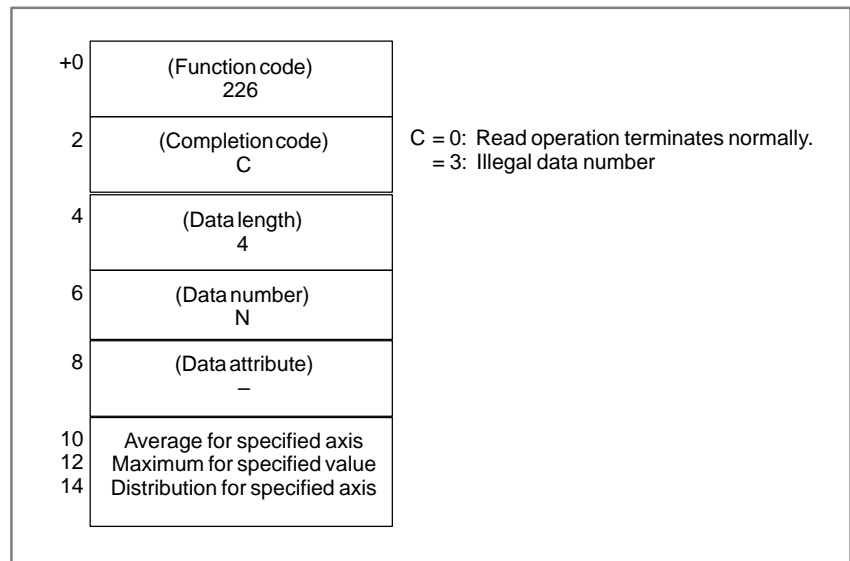
**Caution****CAUTION**

This function is a monitor function for providing detailed disturbance load torque data.

With this function, detailed information about disturbance load on each axis can be monitored. When this monitor function is used to develop and supply, for example, a protection function for a machine or tool, secure operation must be confirmed completely by using the actual machine before the supply of the protection function.

12.1.24 Actual Speed Display

General

The actual speed is displayed on the current position display screen, program check screen, and program screen (MDI mode).

PMC controlled axis movement data can be added to the actual speed display.

Reflection of movement along an arbitrary axis in the actual speed display can also be suppressed by parameter setting.

Parameter

	#7	#6	#5	#4	#3	#2	#1	#0
3105							PCF	DPF

[Data type] Bit

DPF Display of the actual speed on the current position display screen, program check screen and program screen (MDI mode)

0 : Not displayed

1 : Displayed

PCF Addition of the movement of the PMC-controlled axes to the actual speed display

0 : Added

1 : Not added

NOTE

For each setting, movement along any axis other than those controlled by the CNC (see the description of parameter No. 1010) is not reflected in the actual speed display.

	#7	#6	#5	#4	#3	#2	#1	#0
3115					NDFx			

[Data type] Bit axis

NDFx To the actual speed display, axis movement data is:

0 : Added.

1 : Not added.

NOTE

Even if the parameter PCF (bit 1 of parameter No.3105) is set to 0, so as to add PMC controlled axis movement data to the actual speed display, the movement data for a PMC controlled axis for which NDFx is set to 1 is not added to the actual speed display.

12.1.25 Parameter Set Supporting Screen

General

The parameter set supporting screen is a parameter setting and tuning screen intended to help:

- Readily start up the machine by collecting and displaying the minimum required parameters for machine launching.
- Smoothly make adjustments by easily displaying the servo, spindle, and machining parameter tuning screens.

Operation

The following two methods can be used to display the parameter set supporting screen.

- (1) Press the [SYSTEM] function key several times until the parameter set supporting screen appears.

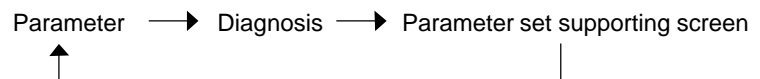

Setting the CPR parameter (bit 2 of parameter No. 3195) to 1 disables the function key from displaying the parameter set supporting screen. If you want to use the conventional method for displaying the screen, use this parameter so that you can follow the method given below.

- (2) Press the [+] soft key several times until the [PRMTUN] soft key appears.
Press the [PRMTUN] soft key to display the parameter set supporting screen.



This screen is called the parameter set supporting screen menu.

Display item overview

The items displayed on the parameter set supporting screen are outlined below.

[START UP]

[START UP] lets you specify the minimum required parameters for machine launching.

AXIS SETTING: The axis, coordinate, feedrate, and acceleration/deceleration CNC parameters are specified.

FSSB (AMP): The FSSB amp setting screen is displayed.

FSSB (AXIS): The FSSB axis setting screen is displayed.

SERVO SETTING: The servo setting screen is displayed.

MISCELLANY: CNC parameters, such as DI/DO and serial spindle parameters, are specified.

[TUNING]

[TUNING] lets you specify display screens for servo, spindle, and high-speed, high-precision machining tuning.

SERVO TUNING: The servo tuning screen is displayed.

SPINDLE TUNING: The spindle tuning screen is displayed.

APC/AI TUNING: The machining parameter tuning screen (for APC, AI-APC, and AI contour control) is displayed.

Selecting items

Press the [(OPRT)] soft key to display the following soft keys:

[<] [SELECT] [] [] [] [] [>]

Place the cursor on the item you want to select.

Press the [SELECT] soft key.

START UP

START UP lets you specify the minimum required parameters for machine launching.

Let us explain the AXIS SETTING and MISCELLANY items. For detailed descriptions about the FSSB (AMP), FSSB (AXIS), and SERVO SETTING items, refer to the respective manuals.

Screen displays

The minimum required CNC parameters for machine launching are collected and subdivided into some groups. They are displayed in groups as follows:

AXIS SETTING item

(BASIC) group: Parameters related to basic setting are displayed.

(COORDINATE) group: Parameters related to coordinates are displayed.

(FEED RATE) group: Parameters related to feedrate are displayed.

(ACC./DEC.) group: Parameters related to acceleration/deceleration are displayed.

MISCELLANY item

(MISC) group: Parameters related to DI/DO and serial spindle settings are displayed.

A brief help message corresponding to a parameter selected with the cursor is displayed.

If a standard value (recommended by FANUC) is available for the parameter, it is also displayed.

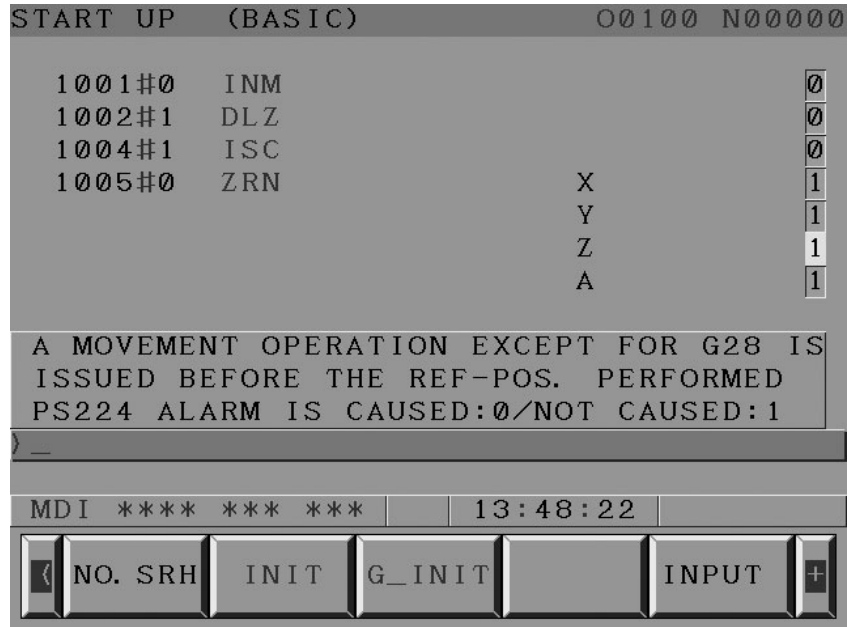

Entering parameters

Make sure that the setting screen is "parameter write enabled."

Select the MDI mode, and place the cursor on the parameter you want to specify.

Enter data, using numeric keys, and press the [INPUT] soft key or the [INPUT] key on the MDI.

[<] [NO. SRH] [INIT] [G_INIT] [] [INPUT] [>]

Displaying the conventional parameter screen

Press the [-] soft key several times until the following soft keys appear.

[<] [PARAM] [DGNOS] [PMC] [SYSTEM] [(OPRT)] [>]

Press the [PARAM] soft key to display the conventional parameter screen.

Displaying the menu screen

To return to the parameter tuning menu screen after an item is selected, operate as follows:

[<] [NO. SRH] [INIT] [G_INIT] [] [INPUT] [>]

Press the [+] soft key to display the [MENU] soft key.

[<] [MENU] [] [] [] [] [>]

Pressing the [MENU] soft key displays the parameter set supporting menu screen.

This operation can let you return to the parameter set supporting menu screen also from the FSSB (AMP), FSSB (AXIS), SERVO SETTING, SERVO TUNING, and SPINDLE TUNING screens.

Setting initial values

Standard values can be specified for parameters, using soft keys.

There are two methods. The first method is to specify a standard value only for the parameter selected with the cursor. The second method is to specify standard values for all parameters in a group.

The standard values are those recommend by FANUC. It is impossible to specify standard values specific to an individual user.

The conventional parameter screen allows no standard value to be set up.

- **Setting initial values for individual parameters**

Select the MDI mode.

Place the cursor on the parameter for which you want to specify a standard value.

Make sure that the following soft keys are displayed, and press the [INIT] soft key.

```
[<] [ NO.SRH ] [ INIT ] [ G_INIT ] [ ] [ INPUT ] [>]
```

The standard value you entered is displayed on the key input line, and the following warning message appears: "Do you really want to perform initialization?"

Press the [EXEC] soft key to set up the standard value.

```
[<] [ ] [ ] [ ] [ CAN ] [ EXEC ] [>]
```

If you want to quit setting the standard value, press the [CAN] soft key.

If no standard value is available for the parameter selected with the cursor, pressing the [INIT] soft key results in the following warning message being displayed: "No standard value is available."

- **Specifying standard values for an entire group**

Select the MDI mode.

Make sure that the following soft keys are displayed, and press the [G_INIT] soft key.

```
[<] [ NO.SRH ] [ INIT ] [ G_INIT ] [ ] [ INPUT ] [>]
```

Instead of a help message, the following message appears:

The following soft key group appears, and the following warning message appears: "Do you really want to perform initialization?"

```
[<] [ ] [ ] [ ] [ CAN ] [ EXEC ] [>]
```

Pressing the [EXEC] soft key causes standard values to be set up for the selected group.

In this case, no standard value is displayed on the key input line. Instead, the setting is automatic. Be extremely careful when using this method.

If you want to quit setting the standard values, press the [CAN] soft key.

Before starting to set up standard values for an entire group, put the machine at an emergency stop for safety purposes.

TUNING

TUNING lets you display the servo, spindle, and machining parameter tuning screens readily, so you can make adjustments easily.

On the parameter tuning screen menu, place the cursor on the desired tuning screen item and press the [SELECT] soft key to display the corresponding screen.

SERVO TUNING: The servo tuning screen is displayed.

SPINDLE TUNING: The spindle tuning screen is displayed.

APC/AI TUNING: The machining parameter tuning screen (for APC, AI-APC, and AI contour control) is displayed.

NOTE

The machining parameter tuning screen (for APC, AI-APC, and AI contour control) will not be displayed unless the machining condition select option is available.

Parameter

	#7	#6	#5	#4	#3	#2	#1	#0
3195						CPR		

[Data type] Bit

CPR Pressing the [SYSTEM] function key:

0 : Displays the parameter setting assistance screen.

1 : Does not display the parameter setting assistance screen.

Notes

- (1) The parameter set supporting screen cannot be used to read or punch parameters.
- (2) Standard value setting can be done only for AXIS SETTING on the parameter set supporting screen and items on other screens. The conventional parameter screen cannot be used to specify standard values.
- (3) If no standard value is available for the parameter you select with the cursor, pressing the [INIT] soft key results in the following warning message being displayed: "There is no standard value."
- (4) If no standard value is available for the group you select, pressing the [G_INIT] soft key results in the following warning message being displayed: "There is no standard value."
- (5) The machining parameter tuning screen does not appear unless the a machining condition select option is available.

Appendix

Parameters required for machine launching

Menu item	Group	Parameter No.	Brief description
AXIS SETTING	BASIC	1001#0	Linear-axis least command increment 0: Millimeter machines 1: Inch machines
		1002#1	Reference position return without dogs 0: Disable 1: Enable (all axes)
		1004#1	Least input increment and least command increment settings 0: IS-B 1: IS-C
		1005#0	Automatic operation (other than G28) with no origin established is responded with: 0: An alarm (No. 224) 1: No alarm
		1005#1	Reference position return without dogs 0: Disable (individual axes) 1: Enable (individual axes)
		1006#0	Selecting linear or rotation axis 0: Linear axis 1: Rotation axis
		1006#3	Specifying a move amount type for individual axes 0: Radius type 1: Diameter type
		1006#5	Direction of a reference position return for individual axes 0: Positive direction 1: Negative direction
		1008#0	Rotation-axis roll-over 0: Disable 1: Enable
		1008#2	Whether to round relative coordinates to a rotation unit: 0: Not to round 1: To round
		1010	Maximum number of axes that the CNC can control
		1020	Individual-axis program name
		1022	Axis assignment in the basic coordinate system
1023	Individual-axis servo axis No.		

Menu item	Group	Parameter No.	Brief description
AXIS SETTING	BASIC	1815#1	Whether to use a separate pulse coder: 0: Not to use 1: To use
		1815#4	Whether the machine position has been associated with the position of the absolute position detector: 0: Associated 1: Not associated
		1815#5	The position detector used is: 0: Not an absolute position detector 1: An absolute position detector
		1825	Individual-axis servo loop gain
		1826	In-position check effective area for individual axes
		1828	Positioning deviation limit for individual axes during movement
		1829	Positioning deviation limit for individual axes at stop
	COORDINATE	1240	First-reference position machine coordinates for individual axes
		1241	Second-reference position machine coordinates for individual axes
		1260	Move amount per rotation-axis rotation
		1320	Positive-direction boundary coordinates for stored stroke check 1
		1321	Negative-direction boundary coordinates for stored stroke check 1
	FEED RATE	1401#6	Whether to enable dry run for rapid traverse 0: To disable 1: To enable
		1410	Dry run speed
		1420	Rapid traverse rate for individual axes
		1421	Rapid traverse override FO speed for individual axes
		1422	Maximum cutting feedrate (common to all axes)
		1423	Jog feedrate for individual axes
		1424	Manual rapid traverse feedrate for individual axes
		1425	FL speed at reference position return for individual axes

Menu item	Group	Parameter No.	Brief description
AXIS SETTING	ACCELERATION/DECELERATION	1610#0	The cutting feed acceleration/deceleration used is: 0: Exponential type acceleration/deceleration 1: Post-interpolation linear-type acceleration/deceleration
		1620	Rapid-traverse linear-type acceleration/deceleration time constant for individual axes
		1622	Cutting feed acceleration/deceleration time constant for individual axes
		1624	Jog feed acceleration/deceleration time constant for individual axes
		1625	Jog feed exponential acceleration/deceleration FL speed for individual axes
MISCELLANY	MISCELLANY	3017	Reset signal output time
		3030	Allowable number of M code digits
		3701#1	Whether to use spindle serial interface for all axes 0: To use 1: Not to use
		7110	Number of manual pulse generators in use

12.1.26 Machining Condition Selecting

General

This function automatically specifies machining conditions when you simply select a precision level that matches your machining purposes when machining. The machining conditions are obtained based on the selected precision level and two prescribed parameter groups (precision-first and velocity-first).

The precision level can be selected from ten steps ranging from 1 (velocity-first) to 10 (precision-first).

It can be selected also on the screen or from the NC program.

NOTE

- 1 This is an optional function.
- 2 This function is usable only with APC, AI contour control, and AI-APC.
- 3 This function is unusable on inch output machines (bit 0 of parameter No. 1001 = 1).

Screen

This function consists of the following two screens.

(1) Machining parameter tuning screen

On this screen, the following parameters are set up for both velocity-first (precision level 1) and precision-first (precision level 10) modes.

- Pre-interpolation acceleration/deceleration rate
- Bell-shaped acceleration/deceleration change time
- Allowable acceleration
- Post-interpolation acceleration/deceleration rate
- Corner feedrate difference
- Maximum allowable cutting feedrate
- Two items that can be set up at the user's discretion

(2) Precision level select screen

On this screen, a precision level that matches your machining purposes can be specified. Parameter values are calculated and displayed according to the precision level corresponding to the velocity-first parameter set (precision level 1) or the precision-first parameter set (precision level 10), whichever is selected.

The precision level can be changed also using program commands.

NOTE

- 1 The bell-shaped acceleration change time is valid only if the pre-interpolation bell-shaped acceleration/deceleration option is available.
- 2 In APC, only the arc radius-based velocity clamp is changed according to the allowable acceleration, because no acceleration-based velocity determination function is available.

Machining parameter tuning screen

On this screen, the velocity-first parameter set (precision level 1) and precision-first parameter set (precision level 10) can be set up.

The screen is displayed by pressing: <SYSTEM> function key → [>] soft key (several times) → [M-TUN].

It can be called also from the parameter tuning screen (by selecting APC/AI TUNING on this screen).

Setting the CPR parameter (bit 0 of parameter No. 13601) to 1 hides this screen.

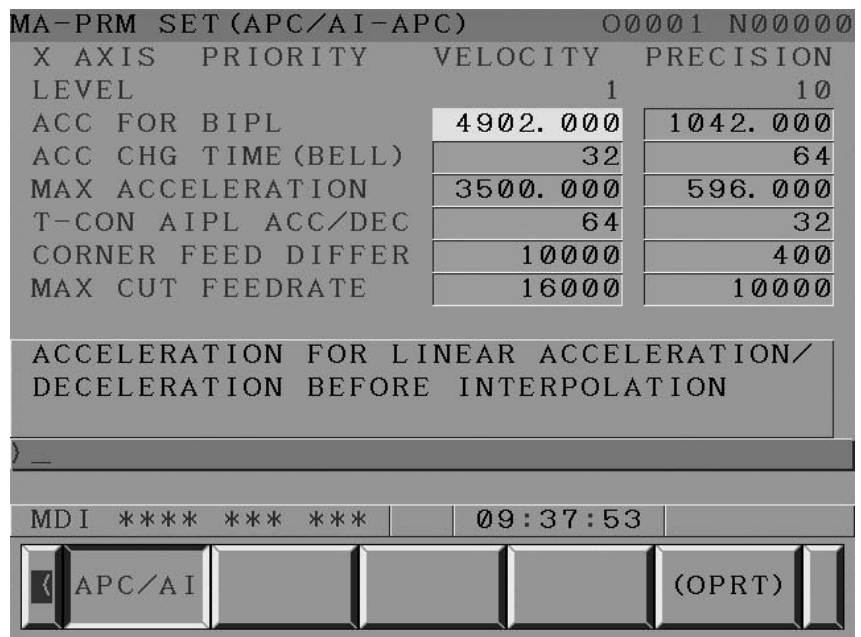

The velocity-first and precision-first parameters can be specified when PWE = 1 (parameter write enabled).

Pressing the [INIT] soft key and then the [EXEC] soft key initializes a cursor-selected item with a standard parameter. Pressing the [G_INIT] soft key and then the [EXEC] soft key initializes all items of a cursor-selected parameter set (velocity-first or precision-first). (Also this operation is usable only when PWE = 1.)

The following table lists the initial values.

Initial values

Item	Velocity-first (LV1)	Precision-first (LV10)	Unit
Pre-interpolation acceleration/ deceleration rate	4902.000	1042.000	mm/sec ²
Bell-shaped acceleration change time	32	64	msec
Allowable acceleration change	0	0	mm/sec ²
Post-interpolation acceleration/ deceleration time constant	24	24	msec
Corner feedrate difference	1000	400	mm/min
Maximum allowable cutting feedrate	10000	10000	mm/min

Precision level select screen

On this screen, it is possible to select a precision level at the midpoint between the velocity-first parameter setting (precision level 1) and the precision-first parameter setting (precision level 10). As shown below, the level changes linearly between the two extreme points. Selecting a level between them can set up an optimum parameter.

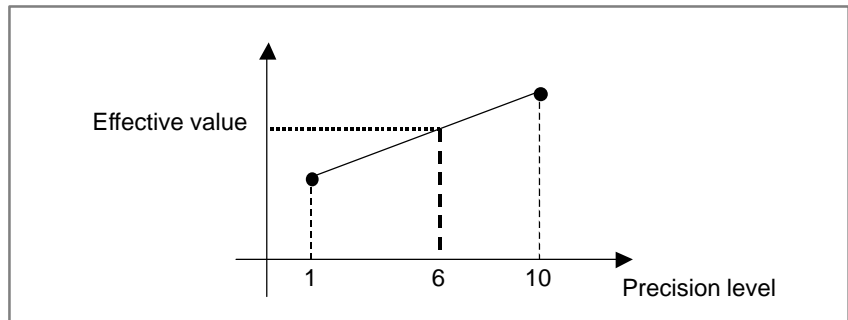

This screen is displayed by pressing: <OFFSET/SETTING> function key → [>] soft key (several times) → [PR_LEV].

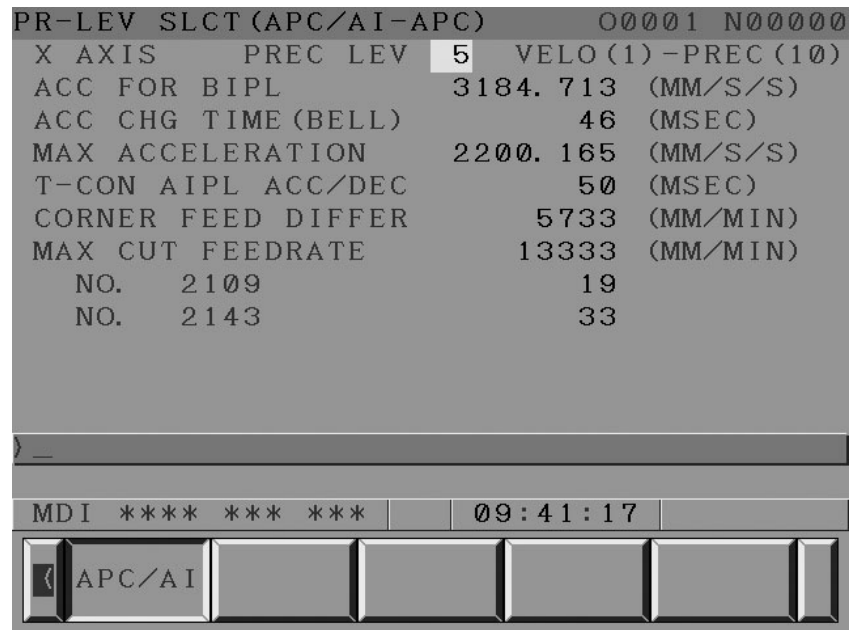

The specified precision level value is not cleared by turning off the power (instead, it is saved to parameter No. 13634).

The precision level is initially '1'. It can be re-set even when PWE = 0 (parameter write disabled) or CPR (bit 0 or parameter No. 13601) = 1 (that is, the machining parameter tuning screen is hidden).

Screen soft keys

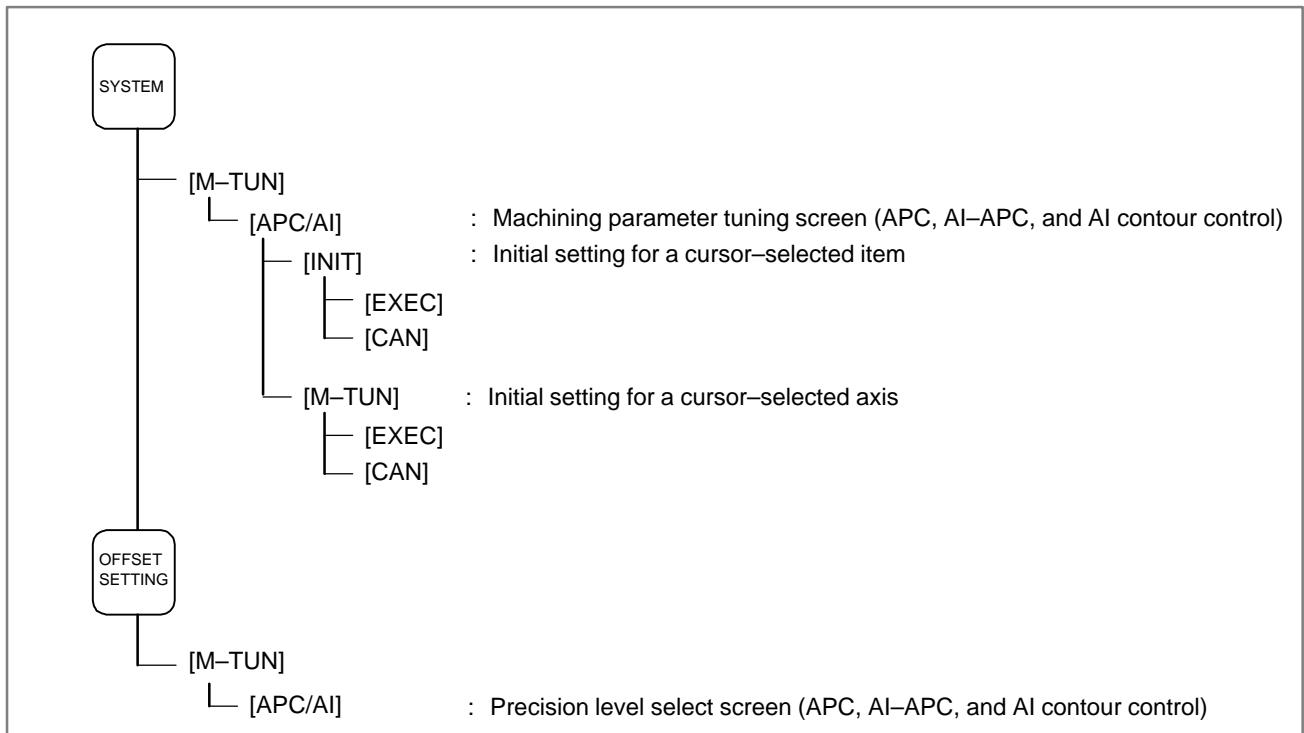

NOTE

- 1 The machine condition select function requires any of the APC, AI-APC, and AI contour control functions.
- 2 Using the bell-shaped acceleration change time for AI contour control requires the "pre-read pre-interpolation bell-shaped acceleration/deceleration" option.
- 3 The effective value of items is rewritten when:
 - The precision level is changed, or
 - The velocity-first or precision-first parameter for the respective items is changed (including the [INIT] and [G_INIT] soft keys).
- 4 If a parameter corresponding to a certain effective value is changed, the parameter value may differ from a value obtained from the velocity-first level, precision-first level, or the current precision level.
- 5 The velocity-first or precision-first parameter group, whichever is selected with the cursor, for the currently displayed axis can be changed at a time by pressing: [G_INIT] R [EXEC].
- 6 Entering values on the machining parameter tuning screen or precision level select screen causes automatic proportional allotment to be performed for the parameter to be tuned. If the automatic proportional allotment fails, leading to an incorrect calculation result, a warning message meaning that automatic setting has failed appears.
- 7 On the machining condition select function screen, an independent PMC axis can be neither displayed nor tuned.

Changing the precision level, using a program

The precision level can be changed not only on the precision level select screen but also using the following program.

```
G05.1 Q1 Rx; (level selecting, using an AI contour control or
              AI-APC mode command)
G08 P1 Rx; (level selecting, using an APC mode command)
x...Level (1 to 10)
```

NOTE

Once the precision level is specified, it remains in effect even when the AI contour control, AI-APC, and APC modes are canceled.

Setting item

● Pre-interpolation acceleration/deceleration rate

This item is used to set up a linear-portion acceleration for pre-interpolation acceleration/deceleration (in mm/s²).

Setting range: 50.000 to 99999.999 (mm/s²)

Size: 2-word type

The parameter value set up on the machining parameter tuning screen is saved to the following parameters:

No. 13610: Velocity-first parameter

No. 13611: Precision-first parameter

In addition, the following parameters are set up from the precision level:

No. 1770/1771 (arbitrary integral ratio)

$$\text{Effective value} = \frac{\text{No.1770}}{\text{No.1771}} \times \frac{100}{6} \quad (\text{arbitrary integral ratio for millimeter machines})$$

No. 1770: Maximum allowable machining rate for pre-interpolation linear acceleration/deceleration (in mm/min)

No. 1771: Time elapsed before the maximum allowable machining feedrate for pre-interpolation linear acceleration/deceleration is attained (in ms)

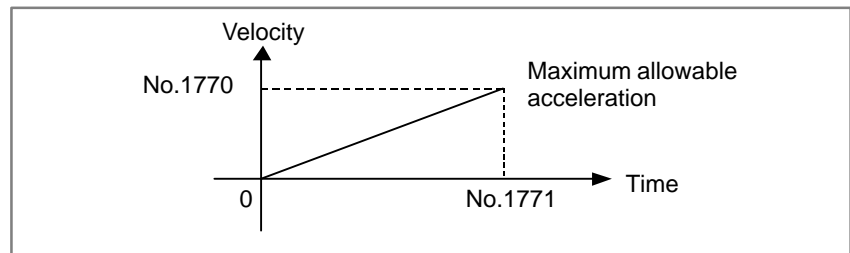

NOTE

The acceleration setting is common to all axes.

● Bell-shaped acceleration change time

This item is used to set up a time constant for the bell-shaped portion of pre-read pre-interpolation acceleration/deceleration (in ms).

Setting range: 0 to 100 [ms]

Size: Byte type

The parameter value set up on the machining parameter tuning screen is reflected on the following parameters:

No. 13612: Velocity-first parameter

No. 13613: Precision-first parameter

In addition, the following parameter is set up according to the precision level:

(AI contour control)

No. 1772: Bell-shaped acceleration/deceleration time constant with a constant pre-read pre-interpolation acceleration time (in ms)

If this item is set with a nonzero value, the following parameter is also set up:

BEL (bit 7 of parameter No. 1603) = 1 (AI contour control only)

NOTE

- 1 This item is disabled for APC and AI APC.
- 2 The time constant mentioned above is common to all axes. Changing this item results in the settings of all axes being changed.

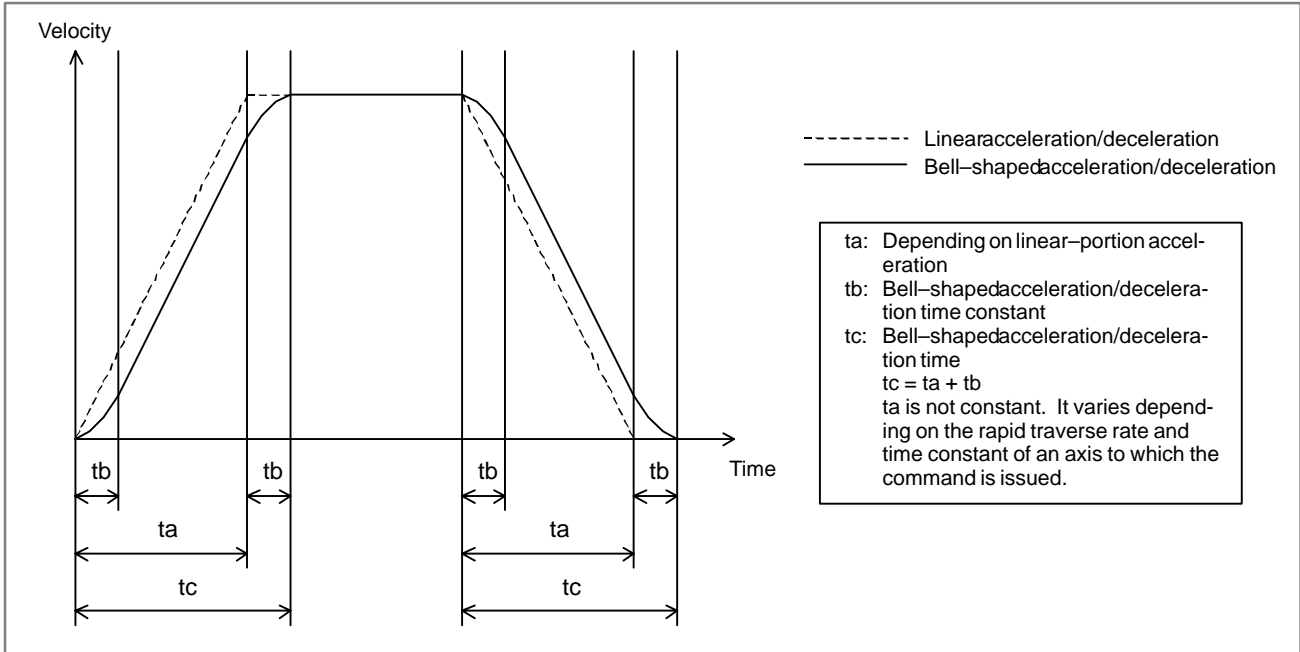

• **Allowable acceleration**

This item is used to set up an allowable acceleration in acceleration-based velocity setup (in mm/s²).

Setting range: 0 to 99999.999 (mm/s² or degrees/s²)

Size: 2-word axis type

For AI contour control and AI APC, the arc radius-based feedrate clamp setting is also changed automatically.

The parameter value specified on the machining parameter tuning screen is reflected on the following parameters:

(APC control/AI contour control/AI APC)

No. 13620: Velocity-first parameter

No. 13621: Precision-first parameter

In addition, the following parameter is set up according to the precision level:

- APC (for rotation axes and millimeter machine linear axes)

$$\begin{aligned} \text{Effective value} &= \frac{(\text{No.1730})^2}{\text{No.1731}} \times \frac{10}{36} \quad (\text{IS-B}) \\ &= \frac{(\text{No.1730})^2}{\text{No.1731}} \times \frac{100}{36} \quad (\text{IS-C}) \end{aligned}$$

Note: Parameter Nos. 1730 and 1731 are set/re-set automatically only when MCR (bit 0 of parameter No. 13600) = 0.

- AI contour control and AI APC (for rotation axes and millimeter machine linear axes)

$$\begin{aligned} \text{Effective value} &= \frac{\text{No.1432}}{\text{No.1785}} \times \frac{100}{6} = \frac{(\text{No.1730})^2}{\text{No.1731}} \times \frac{10}{36} \quad (\text{IS-B}) \\ &= \frac{(\text{No.1730})^2}{\text{No.1731}} \times \frac{100}{36} \quad (\text{IS-C}) \end{aligned}$$

Note: Parameter Nos. 1730 and 1731 are set/re-set automatically only when MCR (bit 0 of parameter No. 13600) = 0.

No. 1785: Time elapsed before the maximum allowable cutting feedrate (No. 1432) is attained (in ms)

No. 1482: Maximum allowable cutting feedrate for individual axes during APC mode (in mm/min or deg/min)

No. 1730: Upper limit to the feedrate for an arc with a radius of R (in mm/min)

No. 1731: Arc radius corresponding to the upper limit to the feedrate (in 0.001 mm)

NOTE

- 1 For AI contour control and AI APC, the arc radius-based feedrate clamp is automatically set or re-set if MCR (bit 0 of parameter No. 13600) = 0.
- 2 Parameter No. 1785 (acceleration-based velocity determination) is unusable during APC. Only the arc radius-based velocity clamp (parameter Nos. 1730 and 1731) is set up. This setting is disabled if MCR (bit 0 of parameter No. 13600) = 1.
- 3 If a different allowable acceleration is specified for each axis, the arc radius-based velocity clamp parameter is set up using the least nonzero allowable acceleration.

• **Post-interpolation acceleration/deceleration time constant**

This item is used to specify a post-interpolation acceleration/deceleration time constant (in ms).

Its type (linear or bell-shaped) is selected according to the settings of parameters BS2 (bit 3 of parameter No. 1602) and LS2 (bit 6 of parameter No. 1602).

Parameter No. 1602		Acceleration/deceleration type
LS2(#6)	BS2(#3)	
1	0	Post-interpolation linear acceleration/deceleration is selected for cutting feed.
0	1	Post-interpolation bell-shaped acceleration/deceleration is selected for cutting feed.

Data range: 8 to 512 [ms]

Size: Word type (common to all axes)

The parameter value specified on the machine parameter tuning screen is reflected on the following parameters (common to all modes):

- No. 13622: Velocity-first parameter
- No. 13623: Precision-first parameter

In addition, the following parameter is set up according to the precision level (common to all modes):

- No. 1769: Post-interpolation linear cutting feed acceleration/ deceleration or post-interpolation bell-shaped cutting feed acceleration/deceleration (specific to each axis)

NOTE

If this parameter is 0 for all axes, parameter No. 1768 (post-interpolation linear acceleration/deceleration time constant common to all axes) is enabled.

● **Corner feedrate difference**

This item is used to specify an allowable feedrate difference for corner feedrate difference-based velocity determination.

If it is anticipated that this setting may be exceeded by the velocity component of an axis at a block boundary, a feedrate that can prevent the setting from being exceeded is obtained and the axis is decelerated to the feedrate, using pre-interpolation acceleration/deceleration.

[Unit of data]
[Valid data range]

Type	Increment system	Unit of data	Valid data range	
			IS-B	IS-C
APC/ AI contour control/ AI APC	Millimeter machine	1 mm/min	6 to 15000	6 to 12000
	Rotation axis	1 deg/min	6 to 15000	6 to 12000

Size: Word axis type

The parameter value specified on the machining parameter tuning screen is reflected on the following parameters:

(APC control/AI contour control/AI APC)

- No. 13624: Velocity-first parameter
- No. 13625: Precision-first parameter

In addition, the following parameter is set up according to the precision level:

(APC control/AI contour control/AI APC)

- No. 1783: Allowable individual-axis feedrate difference for feedrate difference-based automatic deceleration at corner

NOTE

- 1 This setting item is axis-specific. The item for an axis is not interlocked with that for any other axis. So it is necessary to set up the item for all axes individually.
- 2 If this item is specified as 0 for all axes, no deceleration is performed at corners.
- 3 If this parameter is 0 for all axes, parameter No. 1780 (feedrate difference-based allowable feedrate difference of the automatic deceleration at corners common to all axes) is valid for APC.

- **Maximum allowable machining feedrate**

This item is used to specify an axis-specific maximum allowable machining feedrate.

[Unit of data] [Valid data range]	Increment system	Unit of data	Valid data range	
			IS-B	IS-C
	Millimeter machine	1 mm/min	0 to 240000	0 to 100000
	Rotation axis	1 deg/min	0 to 240000	0 to 100000

Size: 2-word axis type

The parameter value specified on the machining parameter tuning screen is reflected on the following parameters (common to all axes):

No. 13626: Velocity-first parameter

No. 13627: Precision-first parameter

In addition, the following parameter is set up according to the precision level (the setting is common to all axes):

No. 1432: Maximum allowable individual-axis feedrate to be applied during APC control/AI contour control/AI APC mode

- **Arbitrary items**

It is possible to register two different types of arbitrary parameters. Each of them can be associated with a CNC parameter or servo parameter (except for a bit type). They are assigned parameter Nos., using a parameter.

- **Setting**

The following table summarizes how each arbitrary item is specified with a parameter No., velocity-first (precision level 1), and precision-first (precision level 10) settings.

	Parameter No.	Velocity-first (precision level 1) value setting	Precision-first (precision level 10) value setting
Arbitrary item (1)	No. 13628	No. 13630	No. 13632
Arbitrary item (2)	No. 13639	No. 13631	No. 13633

- **Display**

The target tuning parameter number is displayed.

NOTE

Any of the following parameter Nos. cannot be specified for arbitrary items.

- Bit-type parameters
- Spindle parameters (Nos. 4000 to 4799)
- Power-off parameter
- Nonexistent parameters

Parameter

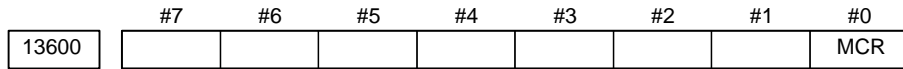

[Data type] Bit

MCR When the permissible acceleration is adjusted with the machining condition selection function (machining parameter adjustment screen or precision level selection screen), parameter Nos. No.1730 and 1731, which are related to feedrate clamping by arc radius, are:

- 0 : Changed.
- 1 : Not changed.

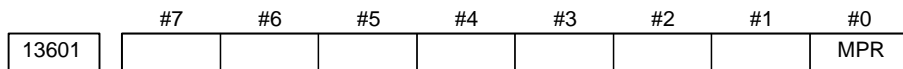

[Data type] Bit

MPR The machining parameter adjustment screen is:

- 0 : Displayed.
- 1 : Not displayed.

NOTE

- 1 When this parameter has been set, the power must be turned off before operation is continued.
- 2 Even when this parameter is set to 1, the precision level selection screen is displayed.

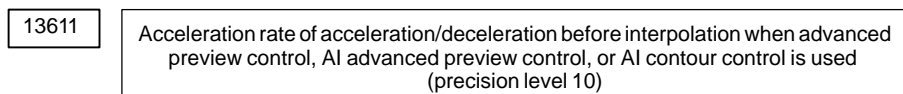
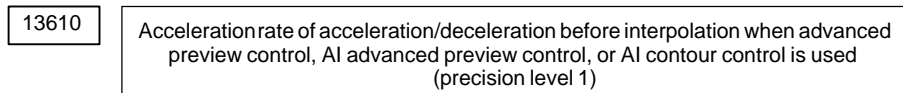

[Data type] 2–word

[Unit of data] %

Increment system	Unit
Millimeter machine	0.001mm/sec ²

[Valid data range] 50000 to 99999999

These parameters set the acceleration rate of acceleration/deceleration before interpolation in advanced preview control, AI advanced preview control, or AI contour control. Two levels including precision level 1, which places emphasis on speed, and precision level 10, which places emphasis on precision, can be set.

13612	Acceleration change time when AI contour control is used (bell-shaped) (precision level 1)
-------	---

13613	Acceleration change time when AI contour control is used (bell-shaped) (precision level 10)
-------	--

[Data type] Byte

[Unit of data] msec

[Valid data range] 1 to 100

These parameters set an acceleration change time (bell-shaped) with emphasis placed on speed (precision level 1) and an acceleration change time (bell-shaped) with emphasis placed on precision (precision level 10) in AI contour control.

13620	Permissible acceleration when advanced preview control, AI advanced preview control, or AI contour control is used (precision level 1)
-------	--

13621	Permissible acceleration when advanced preview control, AI advanced preview control, or AI contour control is used (precision level 10)
-------	---

[Data type] 2-word axis

[Unit of data]	Increment system	Unit
	Millimeter machine	0.001mm/sec ²

[Valid data range] 0 to 99999999

These parameters set a permissible acceleration with emphasis placed on speed (precision level 1) and a permissible acceleration with emphasis placed on precision (precision level 10) in advanced preview control, AI advanced preview control, or AI contour control.

13622	Time constant of acceleration/deceleration after interpolation (precision level 1)
-------	---

13623	Time constant of acceleration/deceleration after interpolation (precision level 10)
-------	--

[Data type] Word axis

[Unit of data] msec

[Valid data range] These parameters set a time constant of linear acceleration/deceleration after interpolation with emphasis placed on speed (precision level 1) and a time constant of linear acceleration/deceleration after interpolation with emphasis placed on precision (precision level 10).
The linear or bell-shaped type is selected by bit 3 (BS2) and bit 6 (LS2) of parameter No. 1602.

Parameter No. 1602		Acceleration/deceleration
LS2(#6)	BS2(#3)	
1	0	Selects linear acceleration/deceleration after cutting feed interpolation.
0	1	Selects bell-shaped acceleration/deceleration after cutting feed interpolation.

NOTE

- 1 For bell-shaped acceleration/deceleration, the function for bell-shaped acceleration/deceleration after cutting feed interpolation is required.
- 2 The same parameters are used in advanced preview control, AI advanced preview control, and AI contour control.

13624	Difference in corner speed when advanced preview control, AI advanced preview control, or AI contour control is used (precision level 1)
-------	--

13625	Difference in corner speed when advanced preview control, AI advanced preview control, or AI contour control is used (precision level 10)
-------	---

[Data type] Word axis

[Unit of data]	Increment system	Unit of data	Valid data range	
			IS-B	IS-C
[Valid data range]	Millimeter machine	1 mm/min	6 to 15000	6 to 12000
	Rotaion axis	1 deg/min	6 to 15000	6 to 12000

These parameters set a permissible speed difference with emphasis placed on speed (precision level 1) and a permissible speed difference with emphasis placed on precision (precision level 10) when the speed is determined by a corner speed difference in advanced preview control, AI advanced preview control, or AI contour control.

13626	Maximum machining speed (precision level 1)
-------	---

13627	Maximum machining speed (precision level 10)
-------	--

[Data type] 2-word axis

[Unit of data]	Increment system	Unit of data	Valid data range	
			IS-B	IS-C
[Valid data range]	Millimeter machine	1 mm/min	6 to 24000	6 to 100000
	Rotaion axis	1 deg/min	6 to 24000	6 to 100000

These parameters set the maximum machining speed for each axis.

13628	Parameter number for arbitrary item 1 when advanced preview control, AI advanced preview control, or AI contour control is used
13629	Parameter number for arbitrary item 2 when advanced preview control, AI advanced preview control, or AI contour control is used

[Data type] Word

[Valid data range] 1 to 65535

These parameters specify parameter numbers corresponding to arbitrary items 1 and 2.

NOTE

- 1 You cannot specify the numbers of the following parameters:
 - Bit parameters
 - Spindle parameters (Nos. 4000 to 4799)
 - Parameters requiring power disconnection (P/S 0 alarm is issued for these parameters.)
 - Nonexistent parameters
- 2 When such a parameter is set, the power must be turned off before operation is continued.

13630	Value of the parameter corresponding to arbitrary item 1 with emphasis placed on speed (precision level 1) when advanced preview control, AI advanced preview control, or AI contour control is used
13631	Value of the parameter corresponding to arbitrary item 2 with emphasis placed on speed (precision level 1) when advanced preview control, AI advanced preview control, or AI contour control is used
13632	Value of the parameter corresponding to arbitrary item 1 with emphasis placed on speed (precision level 10) when advanced preview control, AI advanced preview control, or AI contour control is used
13633	Value of the parameter corresponding to arbitrary item 2 with emphasis placed on speed (precision level 10) when advanced preview control, AI advanced preview control, or AI contour control is used

[Data type] 2–word axis

[Unit of data] Depending on the type of the parameter for an item

[Valid data range] Depending on the type of the parameter for an item

13634	Precision level currently selected when advanced preview control, AI advanced preview control, or AI contour control is used
-------	--

[Data type] Byte

[Valid data range] 1 to 10

The currently selected level is set.

12.1.27 Other Functions

Displaying the main program number during subprogram execution

When a subprogram is being executed, the program number of the main program can be displayed beside the number of the currently running program on a 14-inch screen.

Parameter

	#7	#6	#5	#4	#3	#2	#1	#0
3209								MPD

[Data type] Bit

MPD During subprogram execution, the main program number is:

- 0 : Not displayed.
- 1 : Displayed.

CAUTION

- 1 Because of the problem of the display area, the main program number is not displayed on the 9-inch screen and on the screen displayed in simultaneous multipath display mode.
- 2 The main program number appears only during program execution.

Suppressing display of the screens displayed by the <SYSTEM> function key

When bit 0 (SKY) of setting parameter No. 3208 is set to disable the <SYSTEM> function key on the MDI panel, display of the screens and soft keys of the functions that belong to the <SYSTEM> function key can be suppressed.

Screen switching by the macro executor and C executor is not disabled.

Parameter

	#7	#6	#5	#4	#3	#2	#1	#0
3208								SKY

[Data type] Bit

SKY The <SYSTEM> function key is:

- 0 : Not disabled.
- 1 : Disabled.

12.1.28

FANUC Two-Byte
Character Code Table

The following table lists FANUC two-byte character codes used on the periodic maintenance screen.

	00	02	04	06	08	0A	0C	0E	10	12	14	16	18	1A	1C	1E
0200	あ	あ	い	い	う	う	え	え	お	お	か	が	き	ぎ	く	ぐ
0220	け	げ	こ	ご	さ	ざ	し	じ	す	ず	せ	げ	そ	ぞ	た	だ
0240	ち	ぢ	っ	っ	づ	ず	で	と	ど	な	に	ぬ	ね	の	は	ば
0260	ば	び	っ	つ	ふ	ぶ	ぶ	へ	べ	な	ほ	ぬ	ね	ま	み	む
0280	め	も	び	つ	ふ	ぶ	ぶ	よ	べ	な	ほ	ぬ	ね	ま	み	む
02A0	材	を	ゃ	や	ゆ	ゆ	よ	よ	ら	質	寸	法	外	径	長	素
02C0	面	最	ん	種	類	類	穴	成	形	倣	正	途	中	荒	具	端
02E0	号	仕	小	内	大	大	工	切	削	送	量	開	始	深	主	軸
0300	回	転	数	位	置	決	直	線	時	円	反	現	在	指	令	値
0320	領	域	診	断	操	作	手	引	機	械	残	移	動	次	早	電
0340	源	投	入	間	分	秒	自	運	負	荷	実	使	用	寿	命	新
0360	規	除	隅	取	单	補	能	独	終	了	記	角	溝	刃	幅	広
0380	設	定	一	覧	表	部	炭	合	金	鋼	超	硬	先	付	摩	耗
03A0	仮	想	副	行	挿	消	去	山	高	準	備	完	後	弧	助	扱
03C0	無	視	器	原	登	録	再	処	理	推	画	過	容	編	集	未
03E0	対	相	座	標	示	名	齒	変	呼	馬	力	系	選	達	閉	

	00	02	04	06	08	0A	0C	0E	10	12	14	16	18	1A	1C	1E
0400	禁	復	婦	書	個	桁	稼	由	兩	半	逃	底	逆	下	空	四
0420	觸	平	代	邊	格	子	周	心	本	群	停	止	巾	微	狀	路
0440	範	因	倍	率	注	側	特	殊	距	離	連	統	增	隔	件	初
0460	期	條	經	握	压	扱	陰	隱	右	押	橫	黃	億	屋	化	何
0480	繪	階	概	該	卷	換	氣	起	軌	技	疑	供	共	境	強	教
04A0	掘	線	係	傾	型	檢	權	研	肩	見	驗	元	弦	滅	孔	巧
04C0	控	更	校	構	根	左	差	雜	參	散	產	算	治	耳	式	失
04E0	修	十	從	勝	商	少	尚	昇	植	色	食	伸	信	振	浸	
0500	真	暗	以	意	異	影	銳	越	倆	可	科	果	箇	課	各	拈
0520	核	學	掛	漢	簡	觀	閔	含	却	客	休	急	業	曲	均	筋
0540	繼	計	輕	言	限	互	降	採	濟	細	姿	思	寫	射	斜	者
0560	車	借	縱	重	出	述	術	涉	照	省	章	証	象	身	進	人
0580	凶	違	印	沿	遠	央	奧	往	底	会	解	改	割	活	願	基
05A0	奇	寄	岐	既	近	区	矩	驅	偶	旧	求	球	究	級	欠	結
05C0	口	語	誤	交	厚	項	刻	告	黑	財	策	系	試	資	事	持
05E0	似	積	弱	受	収	純	順	所	序	剩	場	常	飾	水	錐	据
0600	制	整	製	前	全	然	則	屬	即	他	多	存	谷	探	短	徵
0620	鎖	調	頂	鉄	添	頭	同	導	道	熱	年	濃	箱	究	拔	伴
0640	必	百	複	物	文	間	併	忘	末	密	有	余	与	裏	立	略
0660	青	席	石	積	赤	接	折	粗	創	双	搜	太	打	体	待	態
0680	替	段	知	地	致	遲	追	通	伝	得	読	凸	凹	突	鈍	敗
06A0	杯	背	配	品	不	布	並	頁	別	片	返	勉	弁	保	明	滅
06C0	木	目	歪	搖	樣	溶	要	抑	良	輪	和	話	粹	節	說	絕
06E0	千	專	淺	旋	總	走	退	台	第	題	卓	室	柱	柱	鑄	丁
0700	低	訂	肉	日	白	薄	比	皮	被	非	美	普	伏	步	包	門
0720	問	絡	列	万	利	訊	礼	乱	放	枚	約	練	油	劣	例	郭
0740	戾	冷	垂	緑	紫	許	測	精	効	→	↗	↑	↖	←	↙	↓
0760	↘	Q	○	∩	○	■	板	予	〃	家	装	管	粉	等	▽	▽
0780	∞	∞	∞	∞	α	β	程	抗	張	任	破	損	御	足	守	般
07A0	∞	∞	∞	∞	固	每	当	的	詳	鳥	適	論	額	緣	温	給
07C0	∞	∞	∞	∞	護	己	称	樹	脂	料	落	確	認	報	排	性
07E0	生	績	判	搬	砥	θ	島	壁	◇	◇	◇	◇	◇	◇	◇	■

	00	02	04	06	08	0A	0C	0E	10	12	14	16	18	1A	1C	1E
0800	阿慰院衛憶菓効乾	哀易羽液臆貨害寒	愛為雨益牡我慨刊	挨維渦馱乙牙街勸	逢緯唄園恩芽垣喚	惡胃浦延穩賀殼官	旭衣瓜援音雅獲寬	宛遺樽演佳介覺干	案医雲炎夏壞較幹	闇井營煙暇廻革感	鞍育映鉛架快樂慣	伊一榮塩歌怪笠敢	依稻永汚河海括歡	偉員泳王火灰滑汗	委因洩岡花皆株環	威飲英冲華貝刈甘
0820																
0840																
0860																
0880																
08A0																
08C0																
08E0																
0900	看喜議拳鏡屈劇犬	緩希菊虛響熊激猷	缶幾詰魚驚君隙絹	肝揮脚亨凝訓潔具	還机丘享局軍血謙	鑑旗久京極郡月軒	閑棄及競玉刑儉鍵	陷毅吸協勤兄健險	韓祈宮叫錦契兼幻	館季弓挾琴揭券古	岸稀救橋銀敬劍庫	眼徽泣況九景圈戶	岩輝牛狹句莖堅故	顏騎居胸苦警建湖	企擬巨興馳芸憲狐	危犧拒鄉屑迎拳誇
0920																
0940																
0960																
0980																
09A0																
09C0																
09E0																
0A00	顧江国災冊士湿舟	五港穀碎刷姊芝週	午甲酷祭察市綺住	侯稿腰菜撮師捨柔	候絞骨裁擦支煮宿	光綱此載札枝社祝	公考頃際殺死謝縮	勾肯今劑皿私尺熟	喉衡困罪三紙若春	好講婚坂撒詞酒瞬	孝購查阪讚詩首盾	幸郊砂咲贊字授巡	康鉞債昨酸寺需暑	弘香妻索伺磁秋女	拘剛彩錯刺辞習傷	攻克才桜史七臭唱
0A20																
0A40																
0A60																
0A80																
0AA0																
0AC0																
0AE0																
0B00	獎淨陣清占訴東隊	將蒸須盛宣倉俗淹	床錠酢聖尖層卒宅	承職吹声川掃其拓	招唇粹西戰巢揃濯	昭寢遂誓扇争尊託	燒審杉請栓窓村濁	焦森裾静泉草詫奪	笑申澄稅洗騷墮脫	紹神世昔染像妥棚	衝芯是析潛臟耐誰	賞親勢籍船蔵帶嘆	障辛征責銑贈怠担	乘針政跡鮮造滯淡	城震星雪善促袋团	情尽晴舌組息貸彈
0B20																
0B40																
0B60																
0B80																
0BA0																
0BC0																
0BE0																

	00	02	04	06	08	0A	0C	0E	10	12	14	16	18	1A	1C	1E
0C00	暖	男	談	池	築	畜	竹	筑	秩	茶	昼	虫	駐	貯	帳	庁
0C20	彫	挑	朝	町	脹	腸	跳	沈	珍	賃	墜	痛	塚	爪	吊	釣
0C40	庭	廷	提	釘	泥	摘	滴	笛	典	天	展	店	貼	殿	田	吐
0C60	塗	徒	都	砥	努	土	怒	倒	冬	凍	刀	島	東	湯	灯	答
0C80	筒	統	到	藤	討	踏	透	働	堂	胴	銅	峠	德	毒	届	曇
0CA0	謎	鍋	繩	南	軟	難	二	匂	乳	尿	念	燃	粘	惱	腦	農
0CC0	把	波	派	廂	拜	肺	買	壳	博	拍	泊	舶	麦	肌	畑	八
0CE0	罰	版	犯	班	繁	販	飯	盤	否	彼	悲	扉	批	疲	秘	肥
0D00	費	避	飛	尾	鼻	菱	筆	俵	水	票	評	病	浜	貧	敏	夫
0D20	婦	富	怖	浮	父	符	腐	武	舞	封	風	服	福	腹	弘	沸
0D40	噴	憤	奮	紛	丙	兵	幣	柄	米	壁	癖	偏	便	捕	募	墓
0D60	母	簿	宝	崩	捧	泡	胞	芳	訪	豐	飽	亡	傍	剖	妨	帽
0D80	忙	房	暴	望	紡	肪	膨	防	北	撲	撲	釘	沒	翻	磨	魔
0DA0	幕	膜	迄	滿	味	魅	脈	妙	民	務	夢	矛	迷	鳴	免	綿
0DC0	模	茂	毛	盲	網	默	紋	冶	夜	野	矢	役	藥	躍	諭	輸
0DE0	優	友	遊	郵	融	譽	預	幼	揚	曜	洋	葉	陽	養	浴	翼
0E00	螺	来	頼	欄	陸	律	流	留	粒	旅	療	稜	林	臨	隣	淚
0E20	累	励	鈴	曆	歴	烈	裂	勞	漏	老	六	脇	惑	詫	湾	腕
0E40	幹	椅	菱	宇	嘘	閱	宴	欧	懷	拐	涯	穫	閣	渴	冠	仰
0E60	患	汽	貴	鬼	偽	戲	欺	喫	窮	糾	拋	漁	恐	狂	脊	洪
0E80	緊	愚	遇	靴	啓	慶	憩	携	擊	傑	嫌	懸	嚴	雇	娛	誌
0EA0	紅	耕	航	貢	挫	催	栽	崎	柵	撈	傘	志	施	至	掌	訟
0EC0	識	狩	趣	就	秀	衆	襲	蹴	充	洪	緒	署	諸	叙	族	情
0EE0	鐘	壤	織	紳	醉	瀨	誠	織	漸	繕	塑	礎	阻	奏	族	情
0F00	戴	諾	叩	旦	誕	恥	仲	宙	忠	抽	兆	懲	抵	敵	撤	党
0F20	盜	糖	陶	鬪	督	馴	霸	媒	爆	縛	髮	閔	泌	匹	府	敷
0F40	仏	慕	縫	乏	霧	盟	勇	誘	踊	裸	雷	卯	里	隆	慮	虞
0F60	寮	罌	隸	靈	恋	浪	郎	功	坑	々	々	命	命	命	命	命
0F80	`	abc	def	ghi	jkl	mno	pqr	rst	uvw	xyz	{	:	}	~	〰	〰
0FA0	Б	Г	Д	Ж	З	И	Й	К	Л	М	П	У	Ф	Ц	Ч	Ш
0FC0	À	Á	Â	Ã	Ä	Å	Ç	È	É	Ê	Ë	Ì	Í	Î	Ï	Ò
0FE0	Ä	Å	Ö	Û	Ñ	¿	ç	è	é	ê	ë	ì	í	î	ï	ñ

	00	02	04	06	08	0A	0C	0E	10	12	14	16	18	1A	1C	1E
1000	A	B	C	D	E	F	G	H	I	J	K	L	M	N	O	P
1020	Q	R	S	T	U	V	W	X	Y	Z	a	b	c	d	e	f
1040	g	h	i	j	k	l	m	n	o	p	q	r	s	t	u	v
1060	w	x	y	z	/				γ	ε	μ	π	φ	ω	Δ	Σ
1080	Ω								ガ	ギ	グ	ゲ	ゴ	ザ	ジ	ズ
10A0	バ	ビ	ブ	ベ	ボ	パ	ピ	プ	ペ	ポ	ヴ	カ	ケ	ク	ケ	ア
10C0	オ	オ	カ	ガ	キ	ギ	ク	ダ	ア	ゲ	イ	コ	ツ	ウ	サ	エ
10E0	ス	ズ	セ	ゼ	ソ	ゾ	タ	ダ	チ	ヂ	ッ	ツ	ヅ	テ	デ	ト
1100	ド	ナ	ニ	ヌ	ネ	ノ	ハ	バ	パ	ヒ	ビ	ピ	フ	ブ	プ	ヘ
1120	ベ	ペ	ホ	ボ	ポ	マ	ミ	ム	メン	モ	ャ	ヤ	ユ	ユ	ヨ	エ
1140	ラ	リ	ル	レ	ロ	ワ	ワ	ヲ	ン	ヴ	カ	ケ	ク	ク	ク	ク
1160	—	、	。	、	、	、	、	、	、	、	、	、	、	、	、	、
1180	—	、	、	、	、	、	、	、	、	、	、	、	、	、	、	、
11A0	~			“	”	“	”	“	”	“	”	“	”	{
11C0	}	<	>	《	》	「	」	『	』	【	】	+	-	±	×	÷
11E0	=	≠	<	>	≤	≥	∞	∴	♂	♀	°	'	"	°	¥	\$
1200	¢	£	%	#	&	*	@	§	☆	★	○	●	◎	◇	◆	□
1220	■	△	▲	▽	▼	※	〒	→	←	↑	↓	=	□	△	◇	□
1240	1/1	2/2	3/3	4/4	5/5	6/6	☒	00	mm	cm	km	cm ²	m ²	km ²	cm ³	m ³
1260	mg	kg	cc	dl	l	kl	ms	us	ns	HP	ps	Hz	楯	©		
1280	亜	芦	尉	壹	逸	芋	姻	韻	詠	疫	悦	調	猿	毆	翁	虞
12A0	卸	嫁	禍	彦	蚊	餓	悔	塊	戒	嚇	岳	檉	喝	裼	轄	且
12C0	勘	堪	棺	款	憾	艦	頑	忌	紀	飢	棋	宜	儀	吉	虐	朽
12E0	凶	峽	恭	矯	曉	斤	桐	菌	謹	襟	吟	限	勲	薰	患	溪
1300	螢	鷄	鯨	遣	賢	繭	顯	玄	孤	枯	鼓	吳	悟	碁	后	恒
1320	皇	慌	醇	拷	豪	獄	昆	恨	紺	魂	墾	懇	佐	峻	詐	宰
1340	齋	歲	搾	棧	豪	慘	暫	氏	司	社	肢	嗣	飼	雌	賜	諮
1360	見	侍	滋	慈	蠶	疾	執	漆	舍	赦	遮	邪	飼	雌	酌	爵
1380	寂	朱	珠	儒	蠶	州	宗	拾	愁	酬	醜	邪	飼	雌	酌	爵
13A0	肅	塾	俊	旬	蠶	州	循	潤	遵	庶	如	汁	飼	雌	酌	爵
13C0	償	抄	昌	晶	囚	殉	宵	症	祥	庶	粧	徐	飼	雌	酌	爵
13E0	償	嬢	昌	釀	殖	沼	辱	症	娠	慎	薪	詔	飼	雌	酌	爵

	00	02	04	06	08	0A	0C	0E	10	12	14	16	18	1A	1C	1E
1400	帥	衰	睡	穗	鍾	隨	髓	樞	崇	菅	畝	姓	齊	牲	逝	婿
1420	脆	夕	斥	隻	惜	拙	竊	撰	仙	踐	錢	遷	薦	禪	祖	租
1440	措	疎	壯	莊	桑	曹	喪	葬	僧	遭	槽	燥	藻	霜	憎	賊
1460	孫	馭	舵	莊	泰	逮	灌	沢	但	丹	胆	鍛	壇	痴	稚	畜
1480	逐	窰	嫡	胎	著	弔	眺	湖	聽	勅	朕	陳	鎮	津	坪	渡
14A0	呈	弟	邸	衷	貞	帝	艇	遞	偵	提	送	哲	徹	澗	斗	屯
14C0	奴	桃	悼	亨	痘	唐	塔	搭	騰	豆	騰	洞	童	匿	篤	漠
14E0	豚	尼	忒	棟	忍	寧	婆	俳	輩	梅	培	陪	賠	伯	迫	
1500	鉢	伐	帆	畔	煩	頒	藩	晚	蛮	妃	披	卑	碑	罷	姬	漂
1520	苗	猫	賓	頻	瓶	扶	赴	膚	賦	附	譜	侮	覆	零	墳	陸
1540	塀	弊	遍	舖	暮	邦	奉	峰	抱	捧	砲	褒	坊	某	冒	貿
1560	謀	朴	牧	墨	堀	奔	凡	盆	麻	妹	埋	又	抹	慢	漫	岬
1580	眠	娘	銘	妄	猛	匆	厄	愉	癒	唯	幽	悠	猶	裕	雄	憂
15A0	羊	庸	窰	擁	謠	翌	羅	齡	濫	吏	痢	履	柳	竈	疏	涼
15C0	獵	陵	僚	糧	厘	倫	零	齡	麗	廉	鍊	爐	露	童	廊	樓
15E0	賄	國	搖	條	櫻	澤	瀘	碌	緞	鐵	靱	靖	楓	朗	郁	

12.2 EDIT

12.2.1 Part Program Storage Length

General

One of the following part program size can be selected.

CNC model		Series 16i Series 160i Series 160is	Series 18i Series 180i Series 180is	Series 21i Series 210i Series 210is
Part program size				
10m	(4Kbyte)	—	—	○
20m	(8Kbyte)	—	○	☆
40m	(16Kbyte)	○	☆	☆
80m	(32Kbyte)	☆	☆	☆
160m	(64Kbyte)	☆	☆	☆
320m	(128Kbyte)	☆	☆	☆
640m	(256Kbyte)	☆	☆	☆
1280m	(512Kbyte)	☆	☆	☆
2560m (only for 1 path) (1024Kbyte)		☆	☆	—
5120m (only for 1 path) (2048Kbyte)		☆	—	—

○: Standard, ☆: Option, —: Not Available

NOTE

The memory space values are listed as guidelines.
The actual size of a program that can be registered varies
with the number or sizes of the registered programs.

Alarm and message

Number	Message	Description
070	NO PROGRAM SPACE IN MEMORY	Not enough program space remaining. Delete any unnecessary programs, then retry.

Reference item

Series 16i/18i/160i/180i/ 160is/180is	OPERATOR'S MANUAL (For Machining Center) (B-63534EN)	III.11.3.1	Displaying Memory Used and a List of Programs
	OPERATOR'S MANUAL (For Lathe) (B-63524EN)	III.11.3.1	Displaying Memory Used and a List of Programs
Series 21i/210i/210is	OPERATOR'S MANUAL (For Machining Center) (B-63614EN)	III.11.3.1	Displaying Memory Used and a List of Programs
	OPERATOR'S MANUAL (For Lathe) (B-63604EN)	III.11.3.1	Displaying Memory Used and a List of Programs
Series 20i	OPERATOR'S MANUAL (For Manual Milling Machine) (B-64204EN)	III.13.3.1	Displaying Memory Used and a List of Programs
	OPERATOR'S MANUAL (For Manual Lathes) (B-64194EN)	III.13.3.1	Displaying Memory Used and a List of Programs

12.2.2 No. of Registered Programs

General

One of the following size for number of registered programs can be selected.

Part program size	CNC model	Series 16i Series 160i Series 160is	Series 18i Series 180i Series 180is	Series 21i Series 210i Series 210is
	63		○	○
125		☆	☆	☆
200		☆	☆	☆
400		☆	☆	—
1000		☆	☆	—

○: Standard, ☆: Option, —: Not Available

Alarm and message

Number	Message	Description
072	TOO MANY PROGRAMS	The number of programs to be stored exceeded 63 (basic), 125 (option), 200 (option), 400 (option), or 1000(option). Delete unnecessary programs and execute program registration again.

Reference item

Series 16i/18i/160i/180i/ 160is/180is	OPERATOR'S MANUAL (For Machining Center) (B-63534EN)	III.11.3.1	Displaying Memory Used and a List of Programs
	OPERATOR'S MANUAL (For Lathe) (B-63524EN)	III.11.3.1	Displaying Memory Used and a List of Programs
Series 21i/210i/210is	OPERATOR'S MANUAL (For Machining Center) (B-63614EN)	III.11.3.1	Displaying Memory Used and a List of Programs
	OPERATOR'S MANUAL (For Lathe) (B-63604EN)	III.11.3.1	Displaying Memory Used and a List of Programs
Series 20i	OPERATOR'S MANUAL (For Manual Milling Machine) (B-64204EN)	III.13.3.1	Displaying Memory Used and a List of Programs
	OPERATOR'S MANUAL (For Manual Lathes) (B-64194EN)	III.13.3.1	Displaying Memory Used and a List of Programs

12.2.3 Memory Protection Key

General

A key called the data protection key is used to prevent part programs, offset values, parameters, and setting data from being registered, modified, or deleted erroneously.

Signal

Memory protection signal KEY1 to KEY4 <G046#3 to #6>

[Classification] Input signal

[Function] Enables the changing of the memory contents from the MDI panel. Four signals are provided. The operations that can be performed on the contents of memory by each signal vary depending on the setting of bit 7 (KEY) of parameter No. 3290.

When KEY = 0

- KEY1: Enables the input of tool compensation values and the workpiece zero point offset values, and workpiece coordinate systems shift amount.
- KEY2: Enables the input of setting data and macro variables, and tool life management data.
- KEY3: Enables program loading and editing.

- KEY4: Enables PMC data (counter data tables)

When KEY = 1

- KEY1: Enables program loading and editing, as well as the input of PMC parameters.
- KEY2 to KEY4: Not used

[Operation] When a signal is set to 0, the associated operations are disabled.
When a signal is set to 1, the associated operations are enabled.

Parameter write setting signal KEYPRM

<G046#0>

[Classification] Output signal

[Function] When bit 7 (PK5) of parameter No. 3292 is set to 1, this signal can be used to control whether to enable parameter writing.
When parameter PK5 is set to 1, PWE on the setting screen is invalid.

[Operation] When this signal is set to 0, parameter writing is disabled.
When this signal is set to 1, parameter writing is enabled.

Signal address

	#7	#6	#5	#4	#3	#2	#1	#0
G046		KEY4	KEY3	KEY2	KEY1			KEYPRM

Parameter

	#7	#6	#5	#4	#3	#2	#1	#0
3290	KEY	MCM		IWZ	WZO	MCV	GOF	WOF

[Data type] Bit

WOF Setting the tool offset value by MDI key input is:

0 : Not disabled

1 : Disabled (With parameter No.3294 and No.3295, set the offset number range in which updating the setting is to be disabled.)

GOF Setting the tool offset value by MDI key input is:

0 : Not disabled

1 : Disabled (With parameter No.3294 and No.3295, set the offset number range in which updating the setting is to be disabled.)

MCV Setting macro variables and inputting tool life management data by MDI key input is:

0 : Not disabled

1 : Disabled

WZO Setting a workpiece zero point offset value by MDI key input is:

0 : Not disabled

1 : Disabled

IWZ Setting a workpiece zero point offset value or workpiece shift value (T-series) by MDI key input in the automatic operation activation or halt state is:

- 0 : Not disabled
- 1 : Disabled

MCM The setting of custom macros by MDI key operation is:

- 0 : Enabled regardless of the mode.
- 1 : Enabled only in the MDI mode.

KEY For memory protection keys:

- 0 : The KEY1, KEY2, KEY3, and KEY4 signals are used.
- 1 : Only the KEY1 signal is used.

NOTE

The functions of the signals depend on whether KEY = 0 or KEY = 1.

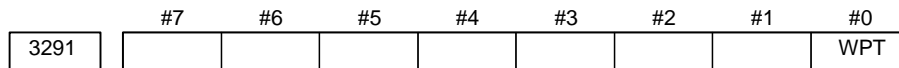

[Data type] Bit

WPT The input of the tool wear compensation amounts is:

- 0 : Enabled according to memory protection key signal KEY1.
- 1 : Always enabled.

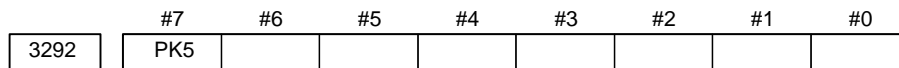

[Data type] Bit

PK5 The KEYPRM signal <G046#3> parameter write setting signal) is:

- 0 : Disabled.
- 1 : Enabled.

NOTE

When this parameter is set, PWE on the setting screen immediately becomes invalid. Carefully set this parameter.

Alarm and message

Warning message	Contents
WRITE PROTECT	Data input is invalid because of memory protect signal.

Reference item

Series 16i/18i/160i/180i/ 160is/180is	OPERATOR'S MANUAL (For Machining Center) (B-63534EN)	III.11	SETTING AND DISPLAYING DATA
	OPERATOR'S MANUAL (For Lathe) (B-63524EN)	III.11	SETTING AND DISPLAYING DATA
Series 21i/210i/210is	OPERATOR'S MANUAL (For Machining Center) (B-63614EN)	III.11	SETTING AND DISPLAYING DATA
	OPERATOR'S MANUAL (For Lathe) (B-63604EN)	III.11	SETTING AND DISPLAYING DATA
Series 20i	OPERATOR'S MANUAL (For Manual Milling Machine) (B-64204EN)	III.13	SETTING AND DISPLAYING DATA
	OPERATOR'S MANUAL (For Manual Lathes) (B-64194EN)	III.13	SETTING AND DISPLAYING DATA

12.2.4 Password Function

General

The password function locks NE9 (bit 4 of parameter No. 3202), used to protect program Nos. 9000 to 9999, by using the PASSWD (No. 3210) and KEYWD (No. 3211) parameters. When NE9 is locked, NE9 cannot be set to 0. Therefore, the protection for programs numbered 9000 to 9999 cannot be released unless the correct keyword is entered.

NE9 is locked when different values are set in the PASSWD and KEYWD parameters. The values set in the two parameters are not displayed. NE9 is unlocked when the value preset in the PASSWD parameter is set in the KEYWD parameter. When 0 is indicated for the PASSWD parameter, a value has not yet been set for PASSWD.

Parameter

	#7	#6	#5	#4	#3	#2	#1	#0
3202				NE9				

[Data type] Bit

NE9 Editing of subprograms with program numbers 9000 to 9999

0 : Not inhibited

1 : Inhibited

The following edit operations are disabled:

- (1) Program deletion (Even when deletion of all programs is specified, programs with program numbers 9000 to 9999 are not deleted.)
- (2) Program output (Even when outputting all programs is specified, programs with program numbers 9000 to 9999 are not output.)

- (3) Program number search
- (4) Program editing after registration
- (5) Program registration
- (6) Program collation
- (7) Displaying programs

3210	Password(PASSWD)
------	------------------

[Data type] Two-word

Set a password to this parameter. Its value is not displayed.

CAUTION

This parameter shows 0, when no value is set to this parameter. Once a key is locked, parameter NE9 cannot become 0 and PASSWD cannot be changed unless you perform an unlock operation or perform the memory all clear operation. When an attempt is made to modify the password by MDI input operation in this state, the warning message "WRITE PROTECTED" is displayed to indicate that the password cannot be modified. When an attempt is made to modify the password with G10 (programmable parameter input), P/S alarm No. 231 is issued.

3211	Keyword(KEYWD)
------	----------------

[Data type] Two-word

When the value set as the password (set in parameter No. 3210) is set the same as this parameter, the locked state is released and the user can now modify the password and the value set in bit 4 (NE9) of parameter No. 3202 becomes 0.

NOTE

The value set in this parameter is not displayed. When the power is turned off, this parameter is set to 0.

Alarm and message

Number	Message	Description
231	FORMAT ERROR IN G10 L50	Any of the following errors occurred in the specified format at the programmable-parameter input. 1) Address N or R was not entered. 2) A number not specified for a parameter was entered. 3) The axis number was too large. 4) An axis number was not specified in the axis-type parameter. 5) An axis number was specified in the parameter which is not an axis type. 6) An attempt was made to reset bit 4 of parameter 3202 (NE9) or change parameter 3210 (PSSWD) when they are protected by a password. Correct the program.

Reference item

Series 16i/18i/160i/180i/ 160is/180is	OPERATOR'S MANUAL (For Machining Center) (B-63534EN)	III.9.9	PASSWORD FUNCTION
	OPERATOR'S MANUAL (For Lathe) (B-63524EN)	III.9.9	PASSWORD FUNCTION
Series 21i/210i/210is	OPERATOR'S MANUAL (For Machining Center) (B-63614EN)	III.9.9	PASSWORD FUNCTION
	OPERATOR'S MANUAL (For Lathe) (B-63604EN)	III.9.9	PASSWORD FUNCTION
Series 20i	OPERATOR'S MANUAL (For Manual Milling Machine) (B-64204EN)	III.9.9	PASSWORD FUNCTION
	OPERATOR'S MANUAL (For Manual Lathes) (B-64194EN)	III.9.9	PASSWORD FUNCTION

12.2.5 Background Editing

General

Editing a program while executing another program is called background editing. The method of editing is the same as for ordinary editing (foreground editing).

A program edited in the background should be registered in foreground program memory.

During background editing, all programs cannot be deleted at once.

Alarm and message

Number	Message	Description
???	BP/S alarm	BP/S alarm occurs in the same number as the P/S alarm that occurs in ordinary program edit. (070, 071, 072, 073, 074 085,086,087 etc.)
140	BP/S alarm	It was attempted to select or delete in the background a program being selected in the foreground. Use background editing correctly.
239	BP/S alarm	Background editing was performed while the external punch was being executed in external I/O device control.
240	BP/S alarm	Background editing was done while in MDI operation.

NOTE

Alarm in background edit is displayed in the key input line of the background edit screen instead of the ordinary alarm screen and is resettable by any of the MDI key operation.

Reference item

Series 16i/18i/160i/180i/ 160is/180is	OPERATOR'S MANUAL (For Machining Center) (B-63534EN)	III.9.8	BACKGROUND EDITING
	OPERATOR'S MANUAL (For Lathe) (B-63524EN)	III.9.8	BACKGROUND EDITING
Series 21i/210i/210is	OPERATOR'S MANUAL (For Machining Center) (B-63614EN)	III.9.8	BACKGROUND EDITING
	OPERATOR'S MANUAL (For Lathe) (B-63604EN)	III.9.8	BACKGROUND EDITING
Series 20i	OPERATOR'S MANUAL (For Manual Milling Machine) (B-64204EN)	III.11.8	BACKGROUND EDITING
	OPERATOR'S MANUAL (For Manual Lathes) (B-64194EN)	III.11.8	BACKGROUND EDITING

12.2.6 Playback

General

When the playback option is selected, the **TEACH IN JOG** mode (TJOG) and **TEACH IN HANDLE** mode (THND) are added. In these modes, a machine position along the X, Y, and Z axes obtained by manual operation is stored in memory as a program position to create a program. The words other than X, Y, and Z, which include O, N, G, R, F, M, S, T, P, Q, and EOB, can be stored in memory in the same way as in **EDIT** mode.

Parameter

	#7	#6	#5	#4	#3	#2	#1	#0
7100							THD	

[Data type] Bit type

THD Manual handle feed in TEACH IN JOG mode

0 : Valid

1 : Invalid

Reference item

Series 16i/18i/160i/180i/ 160is/180is	OPERATOR'S MANUAL (For Machining Center) (B-63534EN)	III.10.3	CREATING PROGRAMS IN TEACH IN MODE
	OPERATOR'S MANUAL (For Lathe) (B-63524EN)	III.10.3	CREATING PROGRAMS IN TEACH IN MODE
Series 21i/210i/210is	OPERATOR'S MANUAL (For Machining Center) (B-63614EN)	III.10.3	CREATING PROGRAMS IN TEACH IN MODE
	OPERATOR'S MANUAL (For Lathe) (B-63604EN)	III.10.3	CREATING PROGRAMS IN TEACH IN MODE
Series 20i	OPERATOR'S MANUAL (For Manual Milling Machine) (B-64204EN)	III.12.3	CREATING PROGRAMS IN TEACH IN MODE
	OPERATOR'S MANUAL (For Manual Lathes) (B-64194EN)	III.10.4	CREATING PROGRAMS IN TEACH IN MODE
CONNECTION MANUAL (This manual)		2.6	MODE SELECTION

12.2.7 Conversational Programming with Graphic Function

General

Programs can be created block after block on the conversational screen while displaying the G code menu.

Blocks in a program can be modified, inserted, or deleted using the G code menu and conversational screen.

Reference item

Series 16i/18i/160i/180i/ 160is/180is	OPERATOR'S MANUAL (For Machining Center) (B-63534EN)	III.10.4	CONVERSATIONAL PRO- GRAMMING WITH GRAPHIC FUNCTION
	OPERATOR'S MANUAL (For Lathe) (B-63524EN)	III.10.4	CONVERSATIONAL PRO- GRAMMING WITH GRAPHIC FUNCTION

12.2.8 Program Copy between Two Paths

General

When the CNC controls two paths, a specified machining program can be copied between the two paths.

There are two copy methods: Single copy and copy with range specification.

- **Single copy**

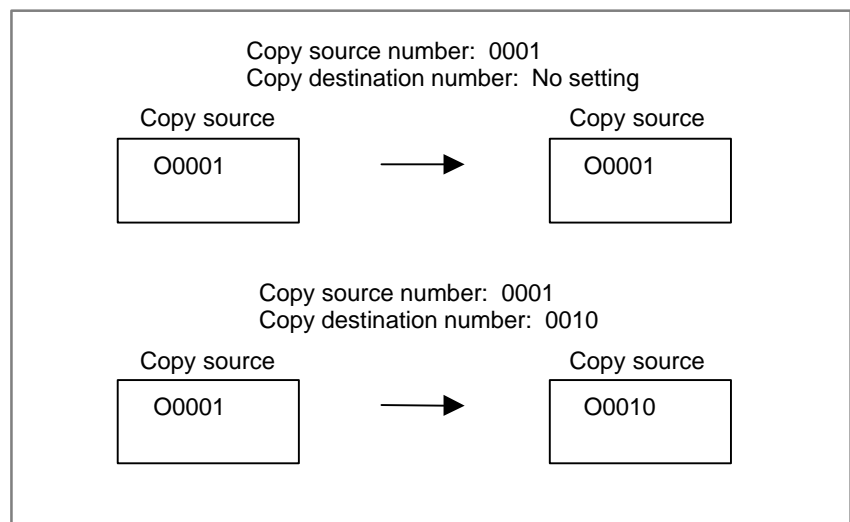

● Copy with range specification

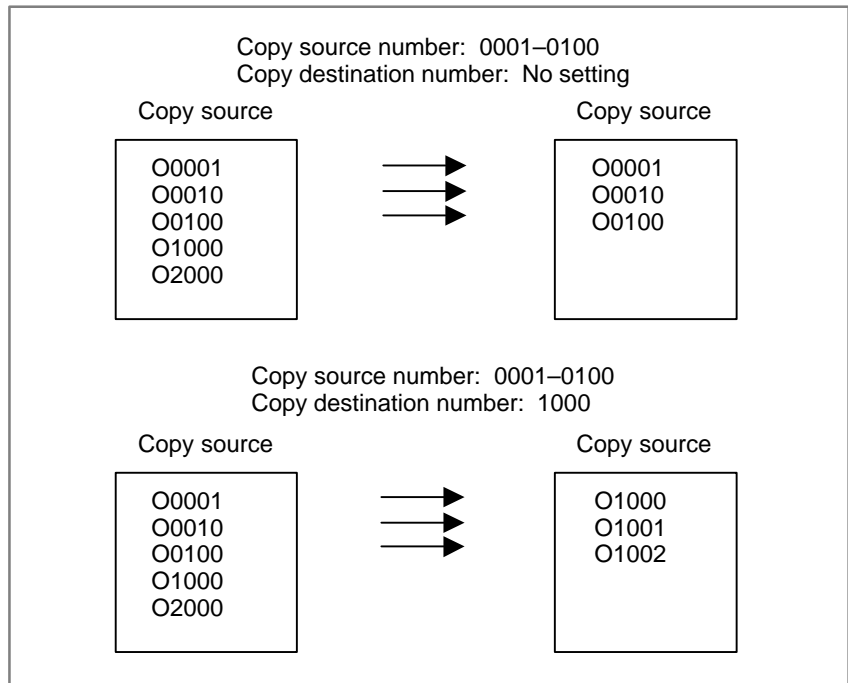

Parameter

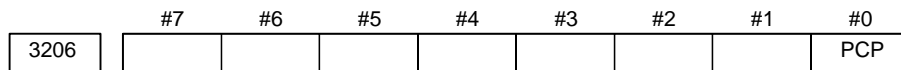

[Data type] Bit

PCP Program copy operation between two paths is:

- 0 : Disabled.
- 1 : Enabled.

Alarm and message

Number	Message	Description
070	NO PROGRAM SPACE IN MEMORY	There is not enough part program storage in the copy destination.
071	DATA NOT FOUND	The address data to be searched for is not found in the copy source.
072	TOO MANY PROGRAMS	The number of programs registered in the copy destination exceeds the maximum number.
073	PROGRAM NUMBER ALREADY IN USE	The program number selected in the copy source is a program number already registered in the copy destination.
075	PROTECT	The program number in the copy source or copy destination is protected.

Caution

CAUTION

- 1 The CNC does not perform copy operation in the following conditions:
 - The data protection key of the copy destination is off.
 - The O number of a program to be copied is the number being protected.
 - The same O number is found in the copy destination (if replacement is set to OFF).
 - There is not enough part program storage in the copy destination.
 - The alarm state is present.
In background editing, copy operation is disabled only when P/S 000 or 101 is issued.
- 2 If part program storage in the copy destination becomes insufficient, the allowable number of registered programs is exceeded, duplicate registration is made, or a protection number is encountered during copy operation with a range specified, the CNC issues an alarm at that point, stopping copy operation.
- 3 Once inter-path copy operation starts, it cannot be interrupted. So before starting copy operation, carefully check that the operation can be started.
- 4 Copy operation is possible also in background editing.
- 5 Even when setting is made to enable replacement, the replacement is not enabled if there is not enough part program storage in the copy destination. Also, a program being executed in background editing cannot be replaced for copy operation.

Reference item

Series 16i/18i/160i/180i/ 160is/180is	OPERATOR'S MANUAL (For Lathe) (B-63524EN)	III.9.10	COPYING A PROGRAM BE- TWEEN TOW PATHS
---	--	----------	--

12.3 ENCRYPTING PROGRAMS

General

This function can protect programs by setting an encryption key specific to the machine tool builder for a system parameter. This function is an option.

Protecting the security of programs using an encryption key

After the encryption key parameter is set, for the programs within the protection range, the following operations are disabled:

- (a) Input (read)
- (b) Output (punch out)
- (c) Display
- (d) Edit

This function can prevent end users from unintentionally editing or modifying custom macro programs provided by the machine tool builder. The contents of these programs are never displayed so that the security can completely be protected.

Inputting and outputting encrypted programs

You can punch out a program registered to memory in encrypted text. You can also read a program punched out in encrypted text into memory. If someone reads the punched out program, he or she cannot understand the contents because the program is encrypted. For this reason, after punching out a program of which security is to be protected, such as a custom macro program created by the machine tool builder, in encrypted text, you can supply the punched out program together with the machine to end users for maintenance purposes. Supplying a custom macro program as described above allows FANUC service personnel and end users to perform recovery when the contents of part program storage is damaged for some reason, without intervention of any service personnel of the machine tool builder.

Details

Setting an encryption key in parameter No. 3220 can lock the programs within the range specified by parameters Nos. 3222 and 3223 to disable the following operations:

- (1) The programs cannot be read.
- (2) The programs cannot be punched out. (They are not punched out even by specifying the punch-out of all programs.)
- (3) The contents of the programs are not displayed.
- (4) The programs cannot be edited. (No program number search can be made.)
- (5) The programs cannot be deleted. (They are not deleted even by specifying the deletion of all programs.)

Setting the same value as for the encryption key in parameter No. 3221 (decryption key) unlocks the programs.

Setting an encryption key

Set encryption key 0 to 99999999 in parameter No. 3220. When a value of 0 is set, the value (0) is displayed to indicate the unlocked state. Setting a value other than 0 locks the programs. The encryption key setting is not displayed for security. Write down the encryption key so as not to forget it. If you do not want to lock programs, be extremely careful so as not to set a value other than 0. If the value set for the encryption key becomes unknown, the programs within the protection range must be all cleared. This operation sets the encryption key to 0 and the unlocked state. At this time, the programs within the protection range have been all cleared to maintain the security.

NOTE

- 1 An encryption key can be set in the unlocked state ([encryption key] = 0 or [encryption key] = [decryption key]). When an encryption key is set, the [+INPUT] soft key is equivalent to the [INPUT] soft key if pressed.
- 2 The encryption key is not erased by all parameter clear operation.
- 3 This parameter is not punched out or read.

Setting a decryption key

To release the key and put the programs in the unlocked state, set the same value as for the encryption key (parameter No. 3220) in the decryption key (parameter No. 3221). The set value is not displayed. At power-on, the value is always 0 internally.

NOTE

- 1 A decryption key can be set at any time. When a decryption key is set, the [+INPUT] soft key is equivalent to the [INPUT] soft key if pressed.
- 2 The decryption key is not erased by all parameter clear operation.
- 3 This parameter is not punched out or read.

Setting the program protection range (minimum and maximum values)

Set the minimum value (No. 3222) and maximum value (No. 3223) of the program numbers within the protection range for locking the programs with numbers 0 to 9999 (0 to 99999999 when the O number 8 digit function is used).

When [minimum value] = 0, a value of 9000 is assumed; when [maximum value] = 0, a value of 9999 is assumed.

Set these values so that [minimum value] < [maximum value].

NOTE

- 1 These values can be set in the unlocked state ([encryption key] = 0 or [encryption key] = [decryption key]).
- 2 The programs within the specified protection range are protected regardless of the settings of bits 0 (NE8) and 4 (NE9) of parameter No. 3202, which specify whether to disable the editing and display of programs Nos. 8000 to 8999 and programs Nos. 9000 to 9999. Any program number search for a program within the protection range by bit 6 (PSR) of parameter No. 3202 is disabled.
- 3 These parameters are not erased by all parameter clear operation.
- 4 These parameters are not punched out or read.

Inputting and outputting programs

● Punching out programs

The following table lists the results of normal punch-out operations.

Operation	Parameter status		Result
	Encryption key	Decryption key	
Punching all programs	≠ 0	≠ [encryption key]	• All programs outside the protection range are punched out in plain text.
		= [encryption key]	• All programs within the protection range are punched out in encrypted text.
	= 0		• All programs are punched out in plain text.
Punching a program with its number specified	≠ 0	≠ encryption key]	• When the program is outside the protection range, it is punched out in plain text. • When the program is within the protection range, an alarm (P/S 071) is issued.
		= encryption key]	• When the program is outside the protection range, it is punched out in plain text. • When the program is within the protection range, it is punched out in encrypted text.
	= 0		• The specified program is punched out in plain text.
Punching programs within the specified range	≠ 0	≠ encryption key]	• The programs outside the protection range are punched out in plain text. • For the programs within the protection range, an alarm (P/S 071) is issued.
		= encryption key]	• The programs outside the protection range are punched out in plain text. • The programs within the protection range are punched out in encrypted text.
	= 0		• The specified programs are punched out in plain text.

NOTE

- 1 To punch out programs in encrypted text, set bit 1 (ISO) of parameter No. 0000 to 1 (ISO code). An attempt to punch out programs in encrypted text with setting 0 (EIA code) causes an alarm (P/S 247).
- 2 The encryption key set in the parameter is also punched out in encrypted text on the tape on which the program is punched out in encrypted text. This is called a password.
- 3 To punch out a program in encrypted text, an option is required.

● **Reading a tape containing encrypted data**

The following table lists the results of normal read operations.

Parameter status		Result
Encryption key	Decryption key	
≠ 0	≠ [encryption key]	• An alarm (P/S 075) is issued.
	= [encryption key]	• The tape is read normally.
= 0		• The password on the tape is set as the encryption key in the parameter, the tape is read, and the locked state is set at the termination or cancellation of reading.

NOTE

- 1 An attempt to read a program outside the protection range causes an alarm (P/S 246).
- 2 An attempt to read the tape by additional program registration causes an alarm (P/S 075).
- 3 Read operations are also performed normally in the locked state. At this time, an attempt may be made to register a program having the program number of an already registered program. In this case, bit 2 (REP) of parameter No. 3201 can be set to specify whether to issue an alarm (P/S 073) or delete the already registered program and register the new program.
- 4 All programs are registered regardless of the setting of bit 1 (RAL) of parameter No. 3201. The M02, M30, and M99 blocks are not assumed to specify the termination of registration regardless of the setting of bit 6 (NPE) of parameter No. 3201.
- 5 The programs on the tape are collated with programs in memory by normal tape collate operation. In the locked state, however, the contents of the tape are not displayed.
- 6 An option is required.

Displaying programs

In the locked state, the contents of the programs within the protection range are not displayed. In the unlocked state, the contents of the programs within the protection range are also displayed in the same way as for normal programs.

Editing and deleting programs

In the locked state, the programs within the protection range cannot be edited. Any program number within the protection range cannot be searched for regardless of the setting of bit 6 (PSR) of parameter No. 3202. The programs cannot also be deleted. As an exception, however, all programs within the protection range can be deleted in the locked state by the following procedure.

● Clearing all programs within the protection range

[Procedure]

- (1) Turn the power on while pressing the <O> and <M> keys on the MDI panel simultaneously.
- (2) The following message appears on the screen.

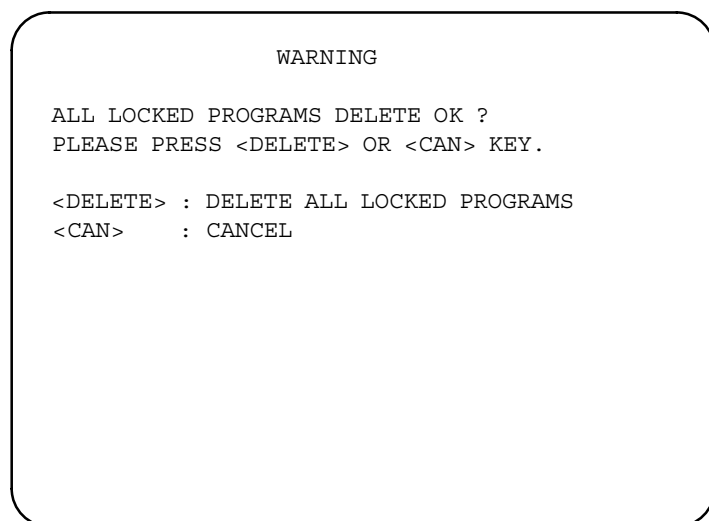

Key in <DELETE> to delete all programs within the protection range. The encryption key set in the parameter is changed to 0 and the unlocked state is set. Key in <CAN> to cancel the deletion.

Workpiece number search/external program number search

Workpiece number search or external program number search by external data input can be used to search for and execute a program within the protection range regardless of whether the locked or unlocked state is set. In the locked state, however, the contents of the program are not displayed.

Parameter

3220	Encryption key
------	----------------

[Data type] 2-word

[Unit of data] None

[Valid data range] 0 to 99999999

This parameter sets an encryption key (password). When a value other than 0 is set, it is regarded as being an encryption key. Once an encryption key has been set, the display of the setting becomes blank and operations such as program editing are locked. The parameter can be set when a value of 0 is set or when the value is the same as the decryption key (parameter No. 3221).

3221	Decryption key
------	----------------

[Data type] 2-word

[Unit of data] None

[Valid data range] 0 to 99999999

When the same value as the encryption key is set in this parameter, the lock is released (unlocked state). The value set in this parameter is not displayed.

3222	Program protection range (minimum value)
------	--

3223	Program protection range (maximum value)
------	--

[Data type] 2-word

[Unit of data] None

[Valid data range] 0 to 9999 (0 to 99999999 when the O number 8 digit function is used)

Those programs whose program numbers are within the range set in these parameters can be locked. Set the minimum and maximum values of the program numbers to be locked.

[Example] When the minimum value is 7000 and the maximum value is 8499, programs O7000 to O8499 are locked.
When the minimum value is 0 and the maximum value is 0, programs O9000 to O9999 are locked.

Alarm and message

Number	Message	Description
PS0075	PROTECT	An attempt was made to register a program having a protected number.
PS0231	FORMAT ERROR IN G10 L50	The following error was detected in the specification format of programmable parameter input: (7) An attempt was made to change the encryption key (parameter No. 3220), decryption key (parameter No. 3221), or program protection range (parameter No. 3222 or 3223) for the program encryption function. Modify the program.
PS0246	ENCODE PROGRAM NUMBER ERROR	An attempt was made to register a program having a number outside the protection range in reading encrypted programs by the reader/puncher interface.
PS0247	ILLEGAL CODE USED FOR OUTPUT	The specified punch code is EIA for outputting an encrypted program by the reader/puncher interface. Specify ISO and output the program.

13

INPUT/OUTPUT OF DATA



13.1 READER/PUNCHER INTERFACE

General

The data shown below can be input/output through reader/puncher interface.

1. Program
2. Offset data
3. Parameter
4. Pitch error compensation data
5. Custom macro common variables.

The above data can be output to a memory card via a memory card interface.

Setting the IO4 parameter (bit 4 of No. 0110) enables I/O channels to be subjected to separate control. In this case, the I/O channels can be categorized into four types, that is, foreground input, foreground output, background input, and background output. When a DNC operation is in the foreground mode, for example, programs can be input/output in the background editing mode.

Parameter

The parameters described below must be set up to use an I/O unit interface (RS-232-C serial port), remote buffer interface, or memory card interface for inputting and outputting data (such as programs and parameters) between external input/output units and memory cards.

The I/O CHANNEL setting parameter is used to select a desired input/output unit by specifying the channel (RS-232-C serial port 1, RS-232-C serial port 2, or remote buffer interface) to which the input/output unit is connected. This is true also when the memory interface is used.

The specified data, such as a baud rate and the number of stop bits, of an input/output device connected to a specific channel of I/O device interface must be set in parameters for that channel in advance.

For channel 1, two combinations of parameters to specify the input/output device data are provided.

The following shows the interrelation between the input/output device interface parameters for the channels of I/O device interface.

Input/output channel number (parameter No. 0020)

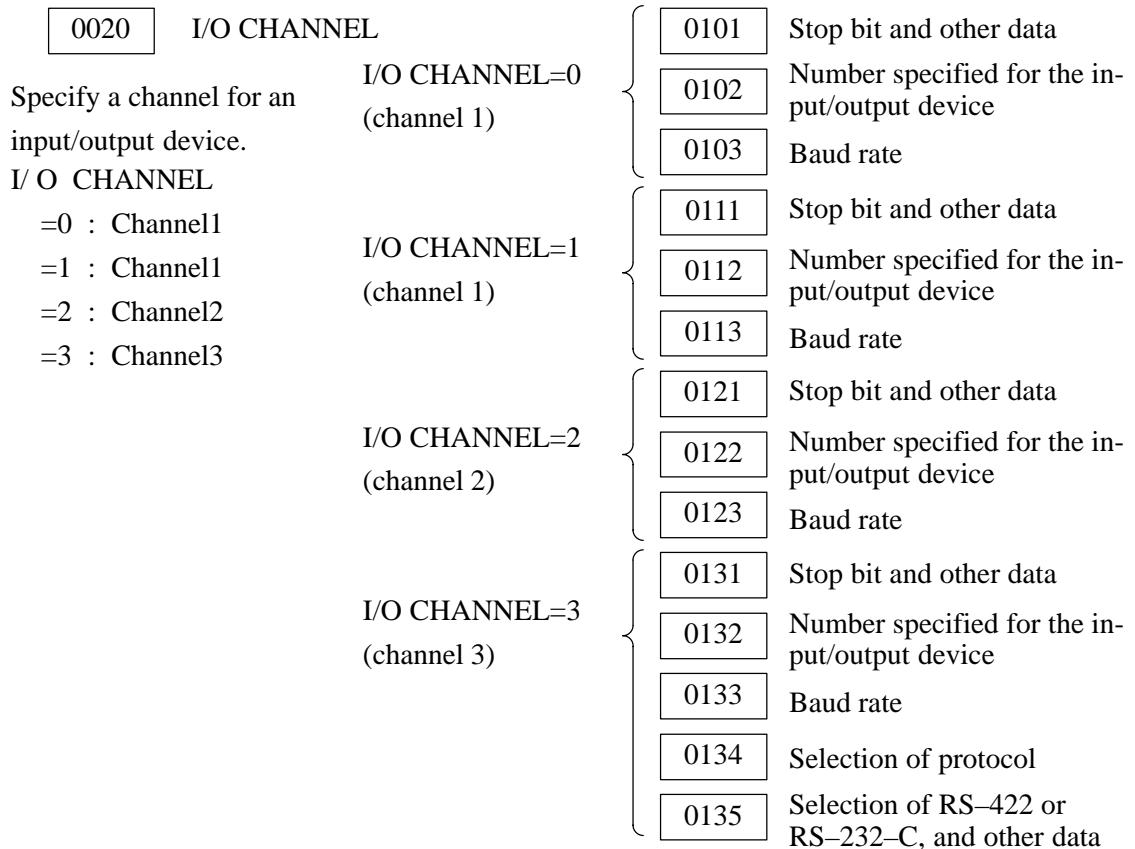

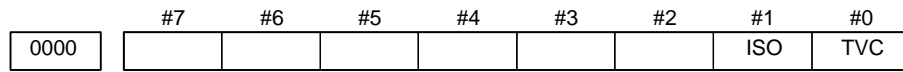

This parameter can be entered on the setting screen

[Data type] Bit

TVC TV check

- 0 : Not performed
- 1 : Performed

ISO Code used for data output

- 0 : EIA code
- 1 : ISO code

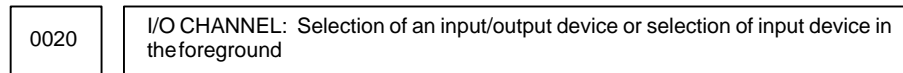

This parameter can be entered on the setting screen

[Data type] Byte

[Valid data range] 0 to 35

I/O CHANNEL: Selection of the input/output device to be used

The CNC provides the following interfaces for data transfer to and from the host computer and external input/output devices:

- Input/output device interface (RS-232C serial port 1, 2)
- Remote buffer interface (RS-232C/RS-422)
- Memory card interface
- DNC1/DNC2 interface

Data input/output is possible with a PC connected via the FOCAS1/Ethernet or FOCAS1/HSSB interface.

In addition, data can be transferred to and from the Power Mate via the FANUC I/O Link.

This parameter selects the interface used to transfer data to and from an input/output device.

Setting	Description
0, 1	RS-232C serial port 1
2	RS-232C serial port 2
3	Remote buffer interface
4	Memory card interface
5	Data server interface
6	The DNC operation is performed or M198 is specified by FOCAS1/Ethernet or DNC1/Ethernet.
9	Embedded Ethernet (The DNC operation and M198 command are disabled.)
10	DNC1/DNC2 interface, OSI-Ethernet
12	DNC1 interface #2
15	M198 is specified by FOCAS1/HSSB. (Bit 1 (NWD) of parameter No. 8706) must also be specified.)
16	The DNC operation is performed or M198 is specified by FOCAS1/HSSB (port 2).

Setting	Description
20	Group 0 Group 1 Group 2 Group 14 Group 15 Data is transferred between the CNC and a Power Mate CNC in group n (n: 0 to 15) via the FANUC I/O Link.
21	
22	
34	
35	

Supplemental remark 1

If the DNC operation is performed with FOCAS1/HSSB, the setting of parameter No. 20 does not matter. The DMMC signal <G042.7> is used.

Supplemental remark 2

If bit 0 (IO4) of parameter No. 110 is set to control the I/O channels separately, the I/O channels can be divided into four types: input and output in the foreground and input and output in the background. If so, parameter No. 20 becomes a parameter for selecting the input device in the foreground.

NOTE

- 1 An input/output device can also be selected using the setting screen. Usually, the setting screen is used.
- 2 The specifications (such as the baud rate and the number of stop bits) of the input/output devices to be connected must be set in the corresponding parameters for each interface beforehand. (See Section 4.2.) I/O CHANNEL = 0 and I/O CHANNEL = 1 represent input/output devices connected to RS-232C serial port 1. Separate parameters for the baud rate, stop bits, and other specifications are provided for each channel.

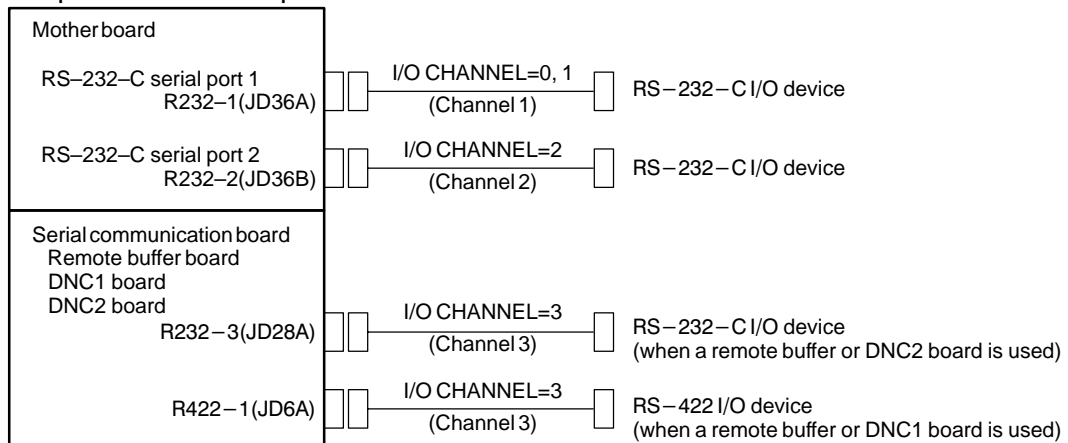

- 3 The input/output unit interface may be referred to as the reader/punch interface. RS-232C serial port 1 and RS-232C serial port 2 are also referred to as channel 1 and channel 2, respectively. The remote buffer interface is also referred to as channel 3.
- 4 JD36A, JD36B, JD28A, and JD6A represent the connector numbers on the printed-circuit board.

0021	Setting of the output device in the foreground
0022	Setting of the input device in the background
0023	Setting of the output device in the background

This parameter can be entered on the setting screen

[Data type] Byte

[Valid data range] 0 to 3, 5, 10

These parameters are valid only when bit 0 (IO4) of parameter No. 110 is set to control the I/O channels separately.

The parameters set individual input/output devices if the I/O channels are divided into these four types: input and output in the foreground and input and output in the background. The input device in the foreground is set in parameter No. 20. For the details of the settings, see the table provided with the description of parameter No. 20.

NOTE

If different input/output devices are simultaneously used in the foreground and background, just a value from 0 to 3 can be specified for the background device.

If an attempt is made to use a busy input/output device, an alarm (P/S233 or BP/S233) will be raised. Note that the settings 0 and 1 indicate the same input/output device.

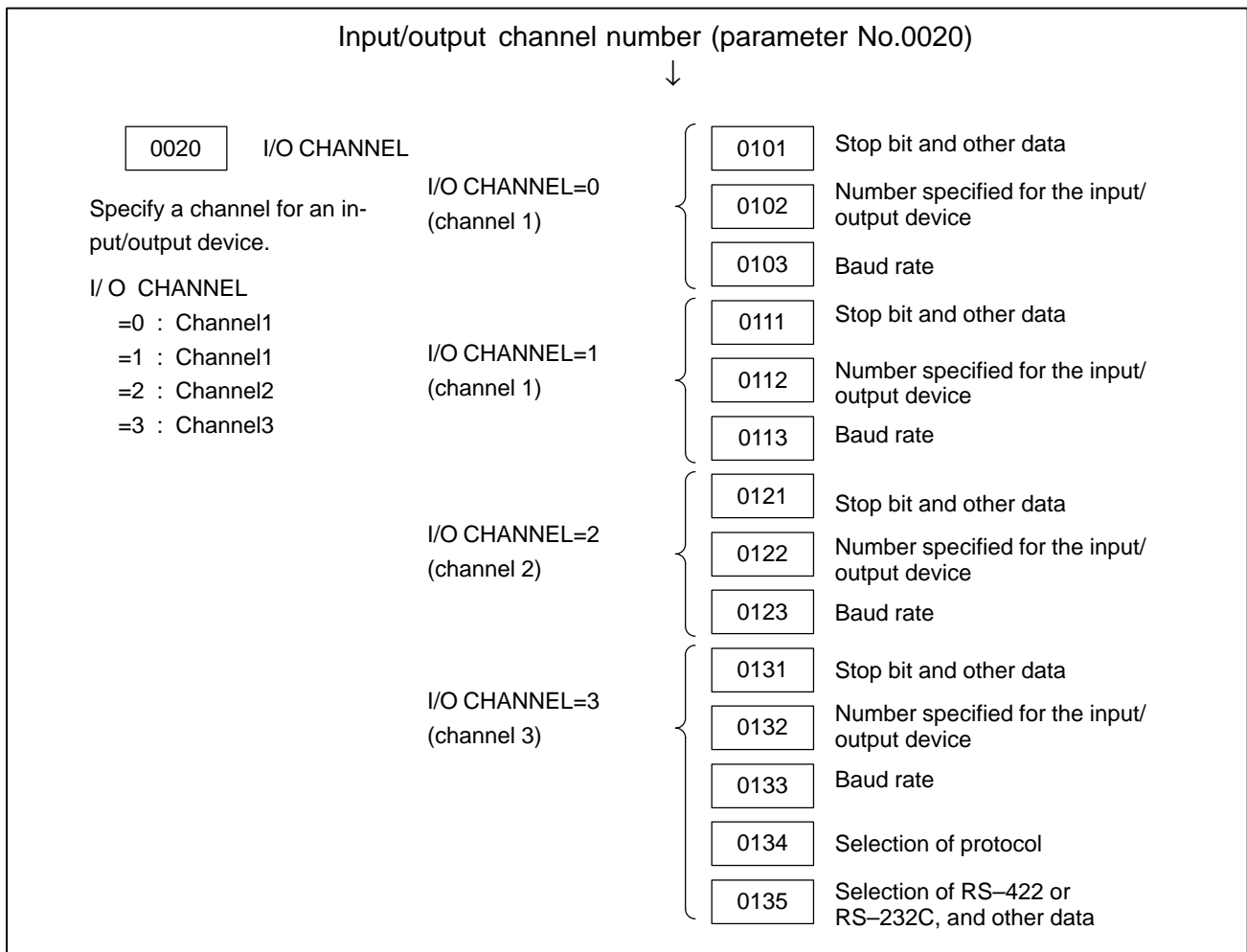

Fig.13.1 I/O Device Interface Settings

(1) Parameters Common to all Channels

0024	Port for communication with the PMC ladder development tool (FANUC LADDER-III)
------	--

This parameter can be entered on the setting screen

[Data type] Byte

This parameter sets the port to be used for communication with the PMC ladder development tool (FANUC LADDER-III).

- 0 : According to the setting on the PMC online screen
- 1 : RS-232C serial port 1 (JD36A)
- 2 : RS-232C serial port 2 (JD36B)
- 10 : High-speed interface (HSSB(COP7) or Ethernet)
- 11 : High-speed interface or RS-232-C serial port 1
- 12 : High-speed interface or RS-232-C serial port 2

	#7	#6	#5	#4	#3	#2	#1	#0
0100	ENS	IOP	ND3		NCR	CRF	CTV	

[Data type] Bit

CTV: Character counting for TV check in the comment section of a program.
 0 : Performed
 1 : Not performed

CRF EOB (end of block) to be output in the ISO code:
 0: Depends on the setting of bit 3 (NCR) of parameter No. 100.
 1: is "CR" "LF".

Note) The EOB output patterns are as shown below:

NCR	CRF	EOB output format
0	0	"LF" "CR" "CR"
0	1	"CR" "LF"
1	0	"LF"
1	1	"CR" "LF"

NCR Output of the end of block (EOB) in ISO code
 0 : LF, CR, CR are output.
 1 : Only LF is output.

ND3 In DNC operation, a program is:
 0 : Read block by block. (A DC3 code is output for each block.)
 1 : Read continuously until the buffer becomes full. (A DC3 code is output when the buffer becomes full.)

NOTE

In general, reading is performed more efficiently when ND3 set to 1. This specification reduces the number of buffering interruptions caused by reading of a series of blocks specifying short movements. This in turn reduces the effective cycle time.

- IOP** Specifies how to stop program input/output operations.
 - 0 : An NC reset can stop program input/output operations.
 - 1 : Only the [**STOP**] soft key can stop program input/output operations.
(An reset cannot stop program input/output operations.)
- ENS** Action taken when a NULL code is found during read of EIA code
 - 0 : An alarm is generated.
 - 1 : The NULL code is ignored.

	#7	#6	#5	#4	#3	#2	#1	#0
0110								IO4

[Data type] Bit

- IO4** Separate control of I/O channel numbers is:
 - 0: Not performed.
 - 1: Performed.

If the I/O channels are not separately controlled, set the input/output device in parameter No. 20.

If the I/O channels are separately controlled, set the input device and output device in the foreground and the input device and output device in the background in parameters No. 20 to No. 23 respectively.

Separate control of I/O channels makes it possible to perform background editing, program input/output, and the like during the DNC operation.

(2) Parameters of Channel 1 (I/O CHANNEL=0)

	#7	#6	#5	#4	#3	#2	#1	#0
0101	NFD				ASI			SB2
	NFD				ASI	HAD		SB2

[Data type] Bit

- SB2** The number of stop bits
 - 0 : 1
 - 1 : 2
- HAD** An alarm raised for the internal handy file is:
 - 0: Not displayed in detail on the NC screen. (PS alarm 86 is displayed.)
 - 1: Displayed in detail on the NC screen.
- ASI** Code used at data input
 - 0 : EIA or ISO code (automatically distinguished)
 - 1 : ASCII code
- NFD** Feed before and after the data at data output
 - 0 : Output
 - 1 : Not output

NOTE
When input/output devices other than the FANUC PPR are used, set NFD to 1.

0102

Number specified for the input/output device (when the I/O CHANNEL is set to 0)

[Data type] Byte

Set the number specified for the input/output device used when the I/O CHANNEL is set to 0, with one of the set values listed in Table 13.1 (a).

Table 13.1 (a) Set value and Input/Output Device

Set value	Input/output device
0	RS-232-C (Used control codes DC1 to DC4)
1	FANUC CASSETTE ADAPTOR 1 (FANUC CASSETTE B1/ B2)
2	FANUC CASSETTE ADAPTOR 3 (FANUC CASSETTE F1)
3	FANUC PROGRAM FILE Mate, FANUC FA Card Adaptor FANUC FLOPPY CASSETTE ADAPTOR, FANUC Handy File FANUC SYSTEM P-MODEL H
4	RS-232-C (Not used control codes DC1 to DC4)
5	Portable tape reader
6	FANUC PPR FANUC SYSTEM P-MODEL G, FANUC SYSTEM P-MODEL H

0103

Baud rate (when the I/O CHANNEL is set to 0)

[Data type] Byte

Set baud rate of the input/output device used when the I/O CHANNEL is set to 0, with a set value in Table 13.1 (b).

Table 13.1 (b)

Set value	Baud rate (bps)	Set value	Baud rate (bps)
1	50	7	600
2	100	8	1200
3	110	9	2400
4	150	10	4800
5	200	11	9600
6	300	12	19200

(3) Parameters of Channel 1 (I/O CHANNEL=1)

	#7	#6	#5	#4	#3	#2	#1	#0
0111	NFD				ASI			SB2

[Data type] Bit

These parameters are used when I/O CHANNEL is set to 1. The meanings of the bits are the same as for parameter 0101.

0112	Number specified for the input/output device (when I/O CHANNEL is set to 1)
------	---

[Data type] Byte

Set the number specified for the input/output device used when the I/O CHANNEL is set to 1, with one of the set values listed in Table 13.1 (a).

0113	Baud rate (when I/O CHANNEL is set to 1)
------	--

[Data type] Byte

Set the baud rate of the input/output device used when I/O CHANNEL is set to 1, with a value in Table 13.1 (b).

(4) Parameters of Channel 2 (I/O CHANNEL=2)

	#7	#6	#5	#4	#3	#2	#1	#0
0121	NFD				ASI			SB2

[Data type] Bit

These parameters are used when I/O CHANNEL is set to 2. The meanings of the bits are the same as for parameter 0101.

0122	Number specified for the input/output device (when I/O CHANNEL is set to 2)
------	---

[Data type] Byte

Set the number specified for the input/output device used when I/O CHANNEL is set to 2, with a value in Table 13.1 (a).

0123	Baud rate (when the I/O CHANNEL is set to 2)
------	--

[Data type] Byte

Set the baud rate of the input/output device used when I/O CHANNEL is set to 2, with a value in Table 13.1 (b).

(5) Parameters of Channel 3 (I/O CHANNEL=3)

	#7	#6	#5	#4	#3	#2	#1	#0
0131	NFD				ASI			SB2

NOTE

When this parameter is set, the power must be turned off before operation is continued.

[Data type] Bit

These parameters are used when I/O CHANNEL is set to 3. The meanings of the bits are the same as for parameter 0101.

0132	Number specified for the input/output device (when I/O CHANNEL is set to 3)
------	---

NOTE

When this parameter is set, the power must be turned off before operation is continued.

[Data type] Byte

Set the number specified for the input/output device used when I/O CHANNEL is set to 3, with a number in Table 13.1 (a).

0133	Baud rate (when the I/O CHANNEL is set to 3)
------	--

NOTE

When this parameter is set, the power must be turned off before operation is continued.

[Data type] Byte

Set the baud rate of the input/output device used when the I/O CHANNEL is set to 3 according to the table 13.1 (c).

Valid data range: 1 to 15 (up to a baud rate of 86400 bps) for the RS-422 interface or 1 to 12 (up to a baud rate of 19200 bps) for the RS-232C interface.

Table 13.1 (c) Baud Rate Settings

Set value	Baud rate (bps)	Set value	Baud rate (bps)
1	50	9	2400
2	100	10	4800
3	110	11	9600
4	150	12	19200
5	200	13	38400
6	300	14	76800
7	600	14	86400
8	1200		

	#7	#6	#5	#4	#3	#2	#1	#0
0134			CLK	NCD			PRY	

NOTE

When this parameter is set, the power must be turned off before operation is continued.

[Data type] Bit

PRY Parity bit

- 0: Not used
- 1: Used

NCD CD (signal quality detection) of the RS-232C interface

- 0: Checked
- 1: Not checked

CLK Baud rate clock when the RS-422 interface is used

- 0: Internal clock
- 1: External clock

NOTE

When the RS-232C interface is used, set this bit to 0.

	#7	#6	#5	#4	#3	#2	#1	#0
0135					R42			ASC

NOTE

When this parameter is set, the power must be turned off before operation is continued.

[Data type] Bit

ASC Communication code except NC data

- 0: ISO code
- 1: ASCII code

R42 Interface

- 0: RS-232C interface
- 1: RS-422 interface

(6) Parameters of Memory Card Interface

	#7	#6	#5	#4	#3	#2	#1	#0
0138	MDN							MDP

[Data type] Bit

MDP In data output by a memory card, the series information is:

0: Not added to the output file name.

1: Added to the output file name.

MDN The DNC operation function by a memory card is:

0: Disabled.

1: Enabled. (A PCMCIA card attachment is required.)

NOTE

Use a PCMCIA card attachment suited to the CNC to secure the memory card in the CNC.

	#7	#6	#5	#4	#3	#2	#1	#0
0300								PCM

[Data type] Bit

PCM If the CNC screen display function is enabled, when a memory card interface is provided on the NC side,

0 : The memory card interface on the NC side is used.

1 : The memory card interface on the PC side is used.

This parameter is valid when parameter No. 0020 is set to 4 (memory card interface).

This parameter is valid only while the CNC screen display function is active.

Alarm and message

Number	Message	Description
001	TH PARITY ALARM	TH alarm (A character with incorrect parity was input). Correct the tape.
002	TV PARITY ALARM	TV alarm (The number of characters in a block is odd). This alarm will be generated only when the TV check is effective.
085	COMMUNICATION ERROR	When entering data in the memory by using Reader / Puncher interface, an overrun, parity or framing error was generated. The number of bits of input data or setting of baud rate or specification No. of I/O unit is incorrect.
086	DR SIGNAL OFF	When entering data in the memory by using Reader / Puncher interface, the ready signal (DR) of reader / puncher was turned off. Power supply of I/O unit is off or cable is not connected or a P.C.B. is defective.
087	BUFFER OVERFLOW	When entering data in the memory by using Reader / Puncher interface, though the read terminate command is specified, input is not interrupted after 10 characters read. I/O unit or P.C.B. is defective.
233	DEVICE BUSY	When an attempt was made to use a unit such as that connected via the RS-232-C interface, other users were using it.
5227	FILE NOT FOUND	A file specified for communication with the built-in handy file unit is missing.
5228	SAME NAME USED	There are duplicate names for files in the built-in handy file unit.
5229	WRITE PROTECTED	A floppy disk in the built-in handy file unit is write-protected.
5230	FILE PROTECTED	In communication with the built-in handy file unit, a file is write- or read-protected.
5231	TOO MANY FILES	In communication with the built-in handy file unit, a limit to the number of files has been exceeded.
5232	DATA OVER-FLOW	There is no free space on a floppy disk in the built-in handy file unit.
5233	TO MANY FD VOLUME	In communication with the built-in handy file unit, a multivolume limit has been exceeded.
5234	FORMAT ERROR	A floppy disk format error has occurred on the built-in handy file unit.

Number	Message	Description
5235	COMMUNICATION ERROR	In communication with the built-in handy file unit, a communication error has occurred.
5236	COMMAND ERROR	In communication with the built-in handy file unit, an incorrect command was issued.
5237	READ ERROR	It is impossible to read from a floppy disk in the built-in handy file unit. It is likely that the floppy disk is abnormal, the magnetic head is dirty, or the hand file unit is defective.
5238	WRITE ERROR	It is impossible to write to a floppy disk in the built-in handy file unit. It is likely that the floppy disk is abnormal, the magnetic head is dirty, or the hand file unit is defective.
5239	SUBPROGRAM ERROR	In communication with the built-in handy file, a subprogram call function was used with a floppy disk, but there is no subprogram file on the floppy disk.

Reference item

Series 16i/18i/160i/180i/ 160is/180is	OPERATOR'S MANUAL (For Machining Center) (B-63534EN)	III.8	DATA INPUT/OUTPUT
	OPERATOR'S MANUAL (For Lathe) (B-63524EN)	III.8	DATA INPUT/OUTPUT
Series 21i/210i/210is	OPERATOR'S MANUAL (For Machining Center) (B-63614EN)	III.8	DATA INPUT/OUTPUT
	OPERATOR'S MANUAL (For Lathe) (B-63604EN)	III.8	DATA INPUT/OUTPUT
Series 20i	OPERATOR'S MANUAL (For Manual Milling Machine) (B-64204EN)	III.8	DATA INPUT/OUTPUT
	OPERATOR'S MANUAL (For Manual Lathes) (B-64194EN)	III.8	DATA INPUT/OUTPUT

13.2 REMOTE BUFFER

Refer to Remote Buffer DESCRIPTIONS (B-61802E-1) for detailed information of remote buffer.

13.3 DNC1 INTERFACE

General

Refer to FANUC DNC1 DESCRIPTIONS(B-61782E) for detailed information of DNC1 interface.

Parameter

0020	I/O CHANNEL: Selection of an input/output device
------	--

Setting entry is acceptable.

[Data type] Byte

Set value. :10

0133	Baud rate
------	-----------

[Data type] Byte

The baud rate of HDLC is fixed to 460 kbps for DNC1.
Set following value:

Set value. :51

NOTE

When this parameter is set, the power must be turned off before operation is continued.

0141	System for connection between the CNC and host (DNC1 interface)
------	---

[Data type] Byte

[Valid data range] 1 or 2

This parameter specifies the system for connection (DNC1 interface) between the CNC and host.

Set value

1 : Point-to-point connection

2 : Multipoint connection

NOTE

When this parameter is set, the power must be turned off before operation is continued.

0142	Station address of the CNC (DNC1 interface)
------	---

[Data type] Byte

[Valid data range] 2 to 52

This parameter specifies the station address of the CNC when the CNC is connected via the DNC1 interface using multipoint connection.

NOTE

When this parameter is set, the power must be turned off before operation is continued.

MAP SCREEN

1. COMMUNICATION SCREEN

(1) Operational Procedure

- 1) Press function key <SYSTEM>.
- 2) Press right-end soft key repeatedly until the soft key [C-SERV],[C-OPER] are displayed shown below:

MDI	***	STOP	***	***	***	12 : 34 : 53
[C-OPER]	[C-SERV]	[]	[(OPRT)]		

(2) Description of screen

(a) Setting screen (one page)

Press soft key [C-OPER] and the following screen is displayed.

```
COMMUNICATION OPERATION                O0001 N00000  
  
DNC FILE SELECTION  
  
  
  
  
  
  
  
  
  
  
>  
MDI   *** STOP *** *** *** 12 : 34 : 53  
  
[C-OPER][C-SERV][           ][           ][ ( OPRT ) ]
```

(b) Service Screen

Press soft key [C-SERV] and the following screen is displayed.
Three pages are available and one of the pages is selected by page key.

COMMUNICATION PARAMETER	O0001	N00000
NC APPLICATION NAME		
HOST APPLICATION NAME		
>		
MDI	*** STOP	*** ** 12 : 34 : 53
[C-OPER][C-SERV][]]]] (OPRT)]

COMMUNICATION PARAMETER	O0001	N00000
CNC STATUS (UNSOLICITED STATUS)		
RISING	UPPER word	00000000 11111111
	LOWER word	11111111 11111111
FALLING	UPPER word	00000000 00000000
	LOWER word	01010100 00000010
INFORMATION REPORT MASK		
	UPPER word	00000000 00000000
	LOWER word	00000000 00000000
CNC ALARM (INFORMATION REPORT)		
	UPPER word	11110001 00000000
	LOWER word	01000001 10000111
>		
MDI	*** STOP	*** ** 12 : 34 : 53
[C-OPER][C-SERV][]]]] (OPRT)]

COMMUNICATION PARAMETER		00001	N00000
PASCAL STACK ADDRESS			
UPPER LIMIT		01ABC000	
LOWER LIMIT		01ABC0FF	
SERVICE MODE	1		
		01010100	00000010
SERVICE MODE	2		
		01000000	00000001
FILE REQUEST TIME OUT			
			12345678
REMOTE REQUEST TIME OUT			
			12345678
>			
MDI	*** STOP ***	***	*** 12 : 34 : 53
[C-OPER][C-SERV][]]]] (OPRT)]

(3) Entry Method

- 1) Setting screen
DNC file selection String input
- 2) Service screen page 1
NC application String input
Host application String input
- 3) Service screen page 2
Status post enable Bit input
Status post mask Bit input
Alarm post Bit input
- 4) Service screen page 3
Pascal stack address Hexadecimal input
Service mode Bit input
File request time-out Integer input
Remote request time-out Integer input
String input: Details are described in Section 1.4, "String Input Mode."
Integer input: Entered as positive integers from 0 to 99999999
Bit input: Entered as 0/1; 00000000 to 11111111
Hexadecimal input: Entered as a hexadecimal number from 00000000 to FFFFFFFF

[Setting procedure]

- 1 Put the system in the MDI mode.
- 2 Switch to the setting screen or service screen to appear, and press the [(OPRT)] soft key.
- 3 Move the cursor to the item you want to specify, using the page and cursor keys.
- 4 Enter the setting value from the keypad, and press the [INPUT] soft key.

(4) String Entry Mode

- 1) On the string input screen, the cursor is placed on top.

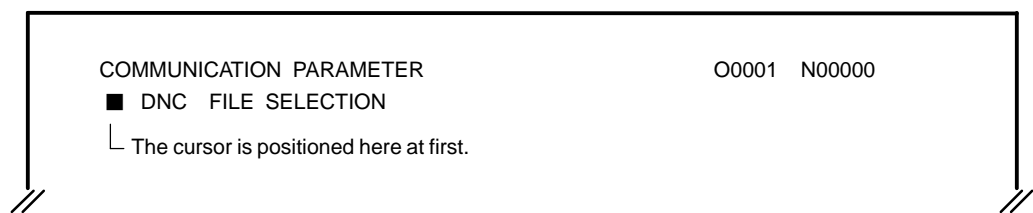

- 2) Press the [(OPRT)] key, and the following soft keys will appear on the screen.

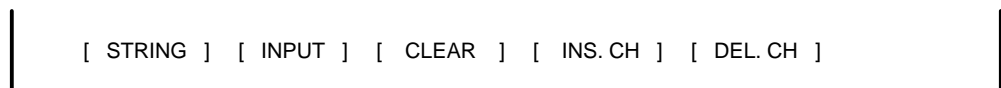

- 3) Press the [STRING] key, then it enters the string input mode.

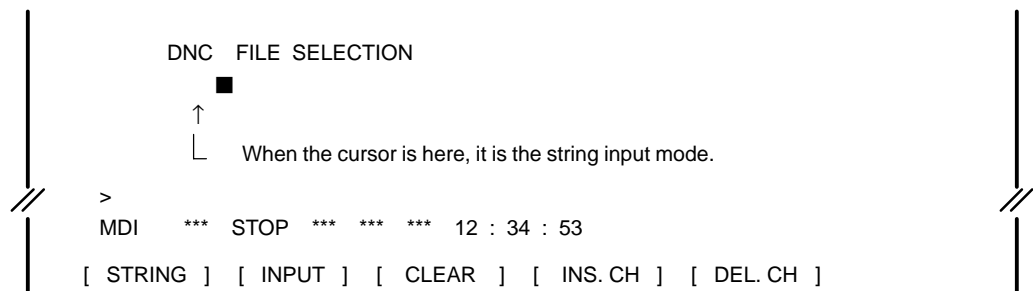

- 4) Specify the DNC file name.
(Example) O1000. PRG

5) Press the [INPUT] soft key to input the values.

```

DNC FILE SELECTION
O1000.PRG■
>
MDI *** STOP *** *** *** 12 : 34 : 53
[ STRING ] [ INPUT ] [ CLEAR ] [ INS.CH ] [ DEL.CH ]

```

6) Deleting the DNC file name

- If you want to delete the entire name, press the [CLEAR] soft key.
- If you want to delete a letter at the cursor, press the [DEL.CH] soft key.

(Example) ABCDEFG■

To delete letter E, move the cursor to that letter:

ABCD**E**FG

Press [DEL.CH], and the result will be:

ABCD**F**G

7) Overwriting

(Example) When you want to overwrite letters starting at C with letters XYZ, move the cursor to letter C.

AB**C**DEFG

Enter "XYZ," then press the [INPUT] soft key.

ABXYZ**F**G

8) Inserting letters

(Example) To insert string ABC after string ABC, move the cursor to letter D.

ABC**D**EF

Enter letters ABC.

ABC**D**EF

Press the [INS.CH] soft key.

ABCABC**D**EF

9) Canceling the string input mode

If you press the [STRING] soft key, the cursor goes back to the position shown below, and the string input mode is canceled.

■ DNC file selection
O1000. PRG

NOTE

- 1 The page keys do not work during the string input mode.
- 2 Switching the CNC mode during a string input mode cancels the string input mode.

2. PARAMETER DESCRIPTION

(1) Setting screen

- DNC file selection
To start DNC operation, specify a file name in the host computer.
Format: Oxxxx. PRG (where xxxx is a four-digit decimal number.)

(2) Service screen

- CNC and host application names
Specify these parameters with CNC and host application names in the string input mode.
- Status post enable
Rising change Upper word: 11111111 11111111
Lower word: 01110000 10111110
Falling change Upper word: 00000000 00000000
Lower word: 11111111 11111111

Each bit in this parameter specifies whether to send the CNC status information to the DNC1 board according to a local request. The CNC status information consists of a bit pattern listed in Table A. Each bit in the bit pattern corresponds to the bits in the rising and falling change words.

Setting value 0: Mask
1: Post

The rising change word specifies that a status information bit change from 0 to 1 be posted, and the falling change word, 1 to 0.

NOTE
Use the lower word only.

○ CNC status information bit pattern (Table A)
Lower word

15	14	13	12	11	10	09	08	07	06	05	04	03	02	01	00
----	----	----	----	----	----	----	----	----	----	----	----	----	----	----	----

Bit position: Signal name — CNC status information —

00: RWD	Rewind signal
01: AL	Alarm output signal
02: RST	Resetting signal
03: SPL	Feed hold lamp signal
04: STL	Cycle start lamp signal
05: OP	Cycle operating signal
06: SA	Servo ready
07: MA	CNC ready
08:	Not used
09:	Not used
10:	Not used
11:	Not used
12: M00	M00 decode output signal (*)
13: M01	M01 decode output signal (*)
14: M02	M02 decode output signal (*)
15: M30	M03 decode output signal (*)

* For the T series (two-path control), bits 08 to 11 correspond to M00 to M30 at HEAD2 respectively, and bits 12 to 15, at HEAD1.

- Status post mask
Not used

- Alarm post
This parameter specifies whether the bit position of a CNC alarm is posted to the host when a status change occurs according to a local request.

Setting value

0: Not to post

1: To post

The relationships between the parameter bits and alarms are as follows:

Upper word bit parameter

31	30	29	28	27	26	25	24	23	22	21	20	19	18	17	16
----	----	----	----	----	----	----	----	----	----	----	----	----	----	----	----

Lower word bit parameter

15	14	13	12	11	10	09	08	07	06	05	04	03	02	01	00
----	----	----	----	----	----	----	----	----	----	----	----	----	----	----	----

Bit number : Alarm type

01: P/S alarm

02: Overheat alarm

05: P/S 100 alarm

06: Overtravel

12: Servo alarm

13: P/S 101 alarm

14: P/S 000 alarm

16: Battery alarm

- Service mode 2

The DNC1 all-file directory information read function works as follows:

00000000 00000001: Only file numbers are read.

00000000 00000000: File numbers and sizes are read.

- File request time-out
- Remote request time-out

This parameter specifies when a time-out is to occur for a request from the host.

Parameter setting: 0 to 99999999

Unit of time: ms

NOTE

1 If value 0 is specified in the parameter, a conventional fixed time of about 25.6 seconds is specified as a time-out value.

2 The time for the time-out is counted in 32 ms units internally. The actual time for a time-out to occur is calculated as:

Actual time-out time =

(parameter setting \div 32 + 1)^(*) x 32 [ms]

(*) The term enclosed in parentheses is rounded down at a decimal point.

13.4 DNC2 INTERFACE

Refer to an item of FANUC DNC2 DESCRIPTIONS (B-61992E) for detailed information of DNC2 interface.

13.5 EXTERNAL I/O DEVICE CONTROL

General

It is possible to request from an external source that a program be registered, collated, or output.

- **Registration/Collation**
As triggered by the external read start signal EXRD, the background edit function saves programs from an external input unit into part program memory and verifies them.
- **Output**
As triggered by the external punch start signal EXWT, the background edit function outputs all programs stored in the part program memory to an external output device.

Signal

External Read Start Signal EXRD <G058#1>

[Classification] Input signal

[Function] Programs are registered through the reader/puncher interface or remote buffer. Read programs are collated with programs already stored in the part program memory.

[Operation] When this signal becomes logical 1, the CNC operates as follows:

- In all modes other than the MDI mode, the background edit function reads programs from an external input device, and register them on the part program memory or collates them with programs already registered in the part program memory.
(The memory protection key KEY3 <G046#5> determines whether to register or collate.)
- Bit 1 (RAL) of parameter No. 3201 selects whether to register all programs in a file or one program at a time. Bit 0 (RDL) of parameter No. 3201 can be used to delete all programs previously stored in the part program memory. However, it is impossible to delete programs protected by bits 0 (NE8) and 4 (NE9) of parameter No. 3202.
- When programs are being registered or collated, the read/punch busy signal (RPBSY) is kept to be logical 1.
- When the background processing-activated signal BGEACT is logical 1 (for example, during background editing or MDI mode), the external read start signal EXRD is ignored.
- When programs are being registered or collated, if the system is reset or the external read/punch stop signal EXSTP becomes logical 1, the registration or collation is discontinued.
- If the foreground processing is already using the reader/puncher interface (for example, during DNC operation or program reading in the edit mode), the external read start signal EXRD is ignored.

- There are some other conditions to determine whether a program can be registered or collated. For example, a program cannot be registered or collated, if a program with the same program number is being executed in the foreground processing.

External Punch Start Signal EXWT <G058#3>

[Classification] Input signal

[Function] Programs stored in the part program memory are output to an external unit via the reader/puncher interface.

[Operation] When this signal becomes logical 1, the CNC operates as follows:

- In all modes other than the MDI mode, the background edit function outputs all programs stored in the part program memory to an external output device.
- When programs are being output, the read/punch busy signal RPBSY becomes logical 1.
- When the background processing-activated signal BGEACT is logical 1 (for example, during background editing or MDI mode), the external punch start signal EXWT is ignored.
- When programs are being output, if the system is reset or the external read/punch stop signal EXSTP becomes logical 1, the output is discontinued.
- If the foreground processing is already using the reader/puncher interface (for example, during DNC operation or program reading in the edit mode), the external punch start signal EXWT is ignored.
- There are some other conditions to determine whether all programs can be output. For example, a program cannot be output, if it is running or protected by bits 0 (NE8) and 4 (NE9) of parameter No. 3202.

External Read/Punch Stop Signal EXSTP <G058#2>

[Classification] Input signal

[Function] When the external read/punch stop signal becomes logical 1, it stops program registration, collation, or output via the reader/puncher interface and program registration and collation via the remote buffer.

[Operation] When this signal becomes logical 1, the CNC operates as follows:

- The program registration, collation or output triggered by the external read or punch start signal is stopped immediately.

**Background editing
signal
BGEACT <F053#4>**

[Classification] Output signal

[Function] This signal indicates that the background edit function is operating.

[Output condition] This signal becomes logical 1 when:

- The [BG EDIT] soft key is pressed to put the CNC in the background edit mode.
- The MDI mode is selected.
- The external read or punch start signal starts program registration, collation, or output.
- Program upload or download is started by the DNC1, DNC2, or MMC.

This signal becomes logical 0 when:

- The [BG END] soft key is pressed to terminate the background edit mode.
- The CNC shifts from the MDI mode to another mode.
- Program registration or output triggered by the external read or punch start signal ends either normally or abnormally (reset or requested by the EXSTP signal).
- Program upload or download started by the DNC1, DNC2, or MMC is ended.

**Read/punch busy signal
RPBSY <F053#2>**

[Classification] Output signal

[Function] This signal indicates that program registration, collation, or output triggered by the external read or punch start signal is under way.

[Output condition] This signal becomes logical 1, when:

- The external read or punch start signal triggers program registration, collation, or output.

This signal becomes logical 0, when:

- Program registration collation or output triggered by the external read or punch start signal ends either normally or abnormally (reset or requested by the EXSTP signal).

Read/punch alarm signal RPALM <F053#3>

[Classification] Output signal

[Function] This signal indicates that an alarm condition has occurred during program registration, collation, or output triggered by the external read or punch start signal.

[Output condition] This signal becomes logical 1, when:

- An alarm condition occurs during program registration, collation, or output triggered by the external read or punch start signal.

This signal becomes logical 0, when:

- The system is reset, or the external read/punch stop signal EXSTP is input.

Signal Address

	#7	#6	#5	#4	#3	#2	#1	#0
G058					EXWT	EXSTP	EXRD	
F053				BGEACT	RPALM	RPBSY		

Parameter

Input/output channel number (parameter No. 0020)



0020	I/O CHANNEL	I/O CHANNEL=0 (channel 1)	0101	Stop bit and other data
Specify a channel for an input/output device. I/O CHANNEL =0 : Channel1 =1 : Channel1 =2 : Channel2 =3 : Channel3	I/O CHANNEL=1 (channel 1)	I/O CHANNEL=2 (channel 2)	0102	Number specified for the in- put/output device
			0103	Baud rate
			0111	Stop bit and other data
I/O CHANNEL=3 (channel 3)	I/O CHANNEL=3 (channel 3)	I/O CHANNEL=3 (channel 3)	0112	Number specified for the in- put/output device
			0113	Baud rate
			0121	Stop bit and other data
I/O CHANNEL=2 (channel 2)	I/O CHANNEL=2 (channel 2)	I/O CHANNEL=2 (channel 2)	0122	Number specified for the in- put/output device
			0123	Baud rate
			0131	Stop bit and other data
I/O CHANNEL=1 (channel 1)	I/O CHANNEL=1 (channel 1)	I/O CHANNEL=1 (channel 1)	0132	Number specified for the in- put/output device
			0133	Baud rate
			0134	Selection of protocol
I/O CHANNEL=0 (channel 1)	I/O CHANNEL=0 (channel 1)	I/O CHANNEL=0 (channel 1)	0135	Selection of RS-422 or RS-232-C, and other data

	#7	#6	#5	#4	#3	#2	#1	#0
3201		NPE	N99			REP	RAL	RDL

[Data type] Bit

- RDL** When a program is registered by input/output device external control
 - 0 : The new program is registered following the programs already registered.
 - 1 : All registered programs are deleted, then the new program is registered.

Note that programs which are protected from being edited are not deleted.
- RAL** When programs are registered through the reader/puncher interface
 - 0 : All programs are registered.
 - 1 : Only one program is registered.
- REP** Action in response to an attempt to register a program whose number is the same as that of an existing program
 - 0 : An alarm is generated.
 - 1 : The existing program is deleted, then the new program is registered.

Note that if the existing program is protected from being edited, it is not deleted, and an alarm is generated.

N99 With an M99 block, when bit 6 (NPE) of parameter No. 3201 = 0, program registration is assumed to be:

- 0 : Completed
- 1 : Not completed

NPE With an M02, M30, or M99 block, program registration is assumed to be:

- 0 : Completed
- 1 : Not completed

	#7	#6	#5	#4	#3	#2	#1	#0
3202				NE9				NE8

[Data type] Bit

NE8 Editing of subprograms with program numbers 8000 to 8999

- 0 : Not inhibited
- 1 : Inhibited

The following edit operations are disabled:

- (1) Program deletion (Even when deletion of all programs is specified, programs with program numbers 8000 to 8999 are not deleted.)
- (2) Program output (Even when outputting all programs is specified, programs with program numbers 8000 to 8999 are not output.)
- (3) Program number search
- (4) Program editing after registration
- (5) Program registration
- (6) Program collation
- (7) Displaying programs

NE9 Editing of subprograms with program numbers 9000 to 9999

- 0 : Not inhibited
- 1 : Inhibited

The following edit operations are disabled:

- (1) Program deletion (Even when deletion of all programs is specified, programs with program numbers 9000 to 9999 are not deleted.)
- (2) Program punching (Even when punching of all programs is specified, programs with program numbers 9000 to 9999 are not punched.)
- (3) Program number search
- (4) Program editing after registration
- (5) Program registration
- (6) Program collation
- (7) Displaying programs

Alarm and message

Number	Message	Description
079	PROGRAM VERIFY ERROR	In memory or program collation, a program in memory does not agree with that read from an external I/O device. Check both the programs in memory and those from the external device.
085	COMMUNICATION ERROR	When entering data in the memory by using Reader / Puncher interface, an overrun, parity or framing error was generated. The number of bits of input data or setting of baud rate or specification No. of I/O unit is incorrect.
086	DR SIGNAL OFF	When entering data in the memory by using Reader / Puncher interface, the ready signal (DR) of reader / puncher was turned off. Power supply of I/O unit is off or cable is not connected or a P.C.B. is defective.
087	BUFFER OVERFLOW	When entering data in the memory by using reader /puncher interface, though the read terminate command is specified, input does not stop after 10 characters read. I/O unit or P.C.B. is defective.
180	COMMUNICATION ERROR (REMOTE BUF)	Remote buffer connection alarm has generated. Confirm the number of cables, parameters and I/O device.
233	DEVICE BUSY	When an attempt was made to use a unit such as that connected via the RS-232-C interface, other users were using it.
239	BP/S ALARM	While punching was being performed with the function for controlling external I/O units, background editing was performed.

Reference item

Series 16 <i>i</i> /18 <i>i</i> /160 <i>i</i> /180 <i>i</i> / 160 <i>is</i> /180 <i>is</i>	OPERATOR'S MANUAL (For Machining Center) (B-63534EN)	III.8.4	PROGRAM INPUT/OUTPUT
	OPERATOR'S MANUAL (For Lathe) (B-63524EN)	III.8.4	PROGRAM INPUT/OUTPUT
Series 21 <i>i</i> /210 <i>i</i> /210 <i>is</i>	OPERATOR'S MANUAL (For Machining Center) (B-63614EN)	III.8.4	PROGRAM INPUT/OUTPUT
	OPERATOR'S MANUAL (For Lathe) (B-63604EN)	III.8.4	PROGRAM INPUT/OUTPUT
Series 20 <i>i</i>	OPERATOR'S MANUAL (For Manual Milling Machine) (B-64204EN)	III.8.4	PROGRAM INPUT/OUTPUT
	OPERATOR'S MANUAL (For Manual Lathes) (B-64194EN)	III.8.4	PROGRAM INPUT/OUTPUT

13.6 SIMULTANEOUS INPUT AND OUTPUT OPERATIONS (M SERIES)

General

While an automation operation is being performed, a program input from an I/O device connected to the reader/punch interface can be executed and stored in memory.

Similarly, a program stored in memory can be executed and output through the reader/punch interface at the same time.

Basic procedure for input and run simultaneous operation

- (1) Search the head of a program (file) you want to run and input.
- (2) Select the DNC operation mode.
- (3) Set the input and run simultaneous mode select signal STRD to logical 1.
- (4) Activate automatic operation.
- (5) The system alternates between outputting one block and running one block of data.

Basic procedure for output and run simultaneous operation

- (1) Select a program you want to run and output.
- (2) Select the DNC operation mode.
- (3) Set the output and run simultaneous mode select signal STWD to logical 1.
- (4) Activate automatic operation.
- (5) The system alternates between outputting one block and running one block of data.

Signal

Input and run simultaneous mode select signal STRD <G058#5>

[Classification] Input signal

[Function] When this signal becomes logical 1, the control unit:

- Selects the input and run simultaneous mode.
To select the input and run simultaneous mode, it is necessary to select the DNC operation mode and to set this signal to logical 1.

Output and run simultaneous mode select signal STWD <G058#6>

[Classification] Input signal

[Function] When this signal becomes logical 1, the control unit:

- Selects the output and run simultaneous mode. To select the output and run simultaneous mode, it is necessary to select the DNC operation mode and to set this signal to logical 1.

Signal address

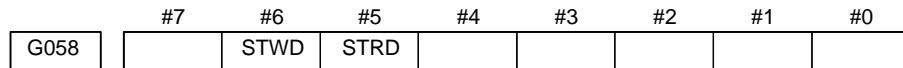

Parameter

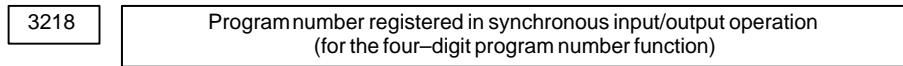

[Data type] Word

[Valid data range] 1 to 9999

This parameter sets a program number for a program that is input by an input/output unit in the simultaneous input/output operation mode and is executed while being stored in memory.

NOTE

- 1 If a value beyond the valid data range is specified, the program number of the input program is assumed.
- 2 When the eight-digit program number function is provided, the program number should not be set in this parameter but in parameter 3219.

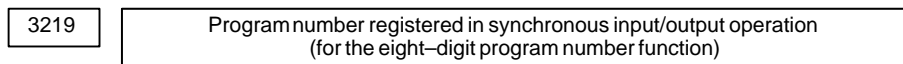

[Data type] 2-word

[Valid data range] 1 to 99999999

This parameter sets a program number for such a program that is input by an input/output unit in the simultaneous input/output operation mode and is executed while being stored in memory.

NOTE

- 1 If a value beyond the valid data range is specified, the number of the input program is registered.
- 2 When the eight-digit program number function is not provided, the program number should not be set in this parameter but in parameter 3218.

Alarm and message

Number	Message	Description
123	CAN NOT USE MACRO COMMAND IN DNC	Macro control command is used during DNC operation. Modify the program.
210	CAN NOT COMAND M198/M99	M198 and M99 are executed in the schedule operation. M198 is executed in the DNC operation. Modify the program.
222	DNC OP. NOT ALLOWED IN BG-EDIT	Input and output are executed at the time in background edit. Execute a correct operation.

Note**NOTE**

- 1 M198 (file access) cannot be executed in the input, output and run simultaneous mode. An attempt to do so results in P/S alarm No. 210.
- 2 A macro control command cannot be executed in the input, output and run simultaneous mode. An attempt to do so results in P/S alarm No. 123.
- 3 If an alarm condition occurs during the input, output and run simultaneous mode, a block being processed when the alarm condition occurs and all blocks before that are input or output.
- 4 In the output and run simultaneous mode, if a device used is a floppy disk drive or FA card, the file name is the execution program number.
- 5 When a program is being executed in the output and run simultaneous mode, if a subprogram is called, only the main program is output.

13.7 EXTERNAL PROGRAM INPUT

General

By using the external program input start signal, a program can be loaded from an input unit into CNC memory.

When an input unit such as the FANUC Handy File or FANUC Floppy Cassette is being used, a file can be searched for using the workpiece number search signals, after which the program can be loaded into CNC memory.

To use external program input start signal MINP <G058#0> to start data input, the following conditions must be satisfied:

- The reader/punch interface function is enabled.
- Bit 7 (MIP) of parameter No. 3201 is set to 1.
- Programs are not protected using the memory protection signal.
- Automatic operation mode is set.
- The current state is other than the start of automatic operation, that is, cycle start lamp signal STL is set to 0. (Automatic operation signal OP may be set to 1.)

Signal

External program input start signal MINP <G058#0>

[Classification] Input signal

[Function] This signal starts the loading of a program from an input unit into CNC memory.

[Operation] When the signal is set to 1, the control unit operates as follows:

- When memory operation mode is set, but no automatic operation is being performed and program loading is not inhibited by the setting of the memory protection key, the CNC deletes all currently loaded programs, then loads a program from the external input unit into CNC memory.
- When the FANUC Handy File or FANUC Floppy Cassette is being used as the input unit, a desired file can be searched for using the workpiece number search signals (PN1 to PN16), after which the program can be loaded into CNC memory.

File numbers are indicated using the workpiece number search signals, as follows:

Workpiece no. search signal					File no.
PN16	PN8	PN4	PN2	PN1	
0	0	0	0	0	00
0	0	0	0	1	01
0	0	0	1	0	02

Workpiece no. search signal					File no.
PN16	PN8	PN4	PN2	PN1	
0	0	0	1	1	03
0	0	1	0	0	04
0	0	1	0	1	05
0	0	1	1	0	06
0	0	1	1	1	07
0	1	0	0	0	08
0	1	0	0	1	09
0	1	0	1	0	10
0	1	0	1	1	11
0	1	1	0	0	12
0	1	1	0	1	13
0	1	1	1	0	14
0	1	1	1	1	15
1	0	0	0	0	16
1	0	0	0	1	17
1	0	0	1	0	18
1	0	0	1	1	19
1	0	1	0	0	20
1	0	1	0	1	21
1	0	1	1	0	22
1	0	1	1	1	23
1	1	0	0	0	24
1	1	0	0	1	25
1	1	0	1	0	26
1	1	0	1	1	27
1	1	1	0	0	28
1	1	1	0	1	29
1	1	1	1	0	30
1	1	1	1	1	31

File No. 00 is used for special specification; specifying file No. 00 means that no search operation is to be performed. Therefore, numbers 01 to 31 can be assigned to files.

[Application] This function is applicable to the following case:
 When a program to be used for machining is too large to be loaded into CNC memory, the program is divided into several segments. These segments are loaded into memory and executed, one by one.

In this case, the general operation flow is as shown below.

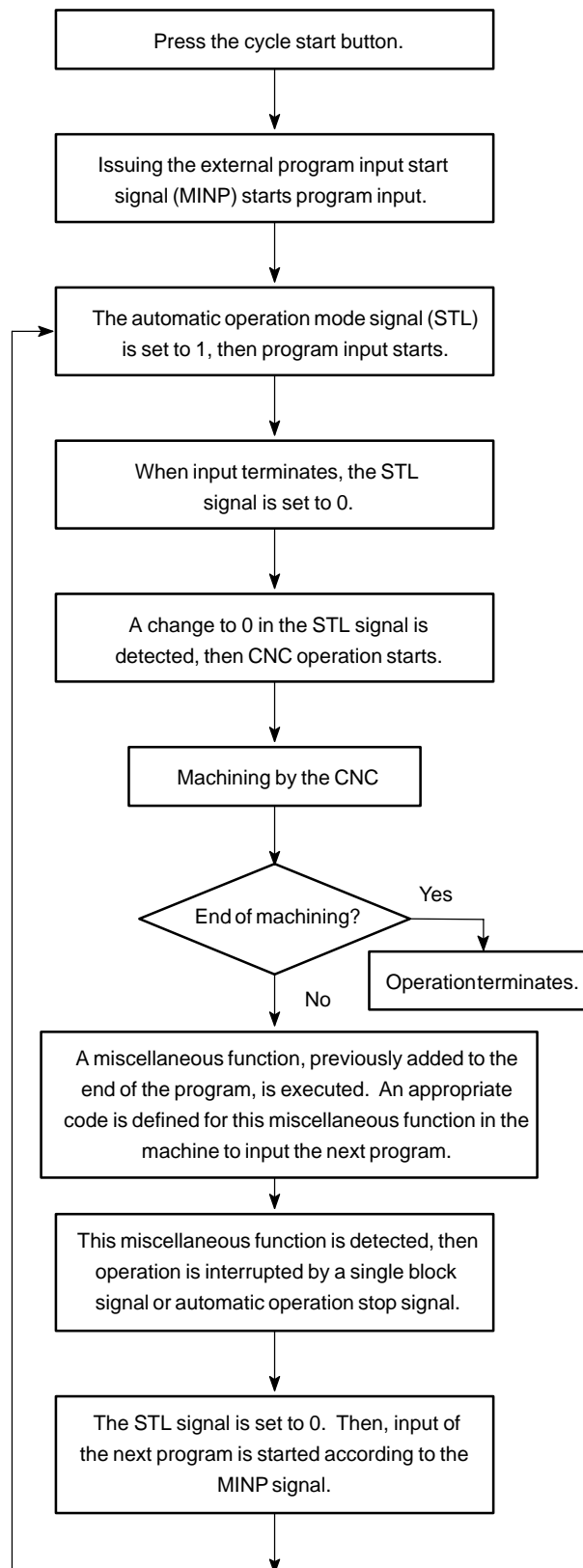

The timing chart for data reading is shown below.

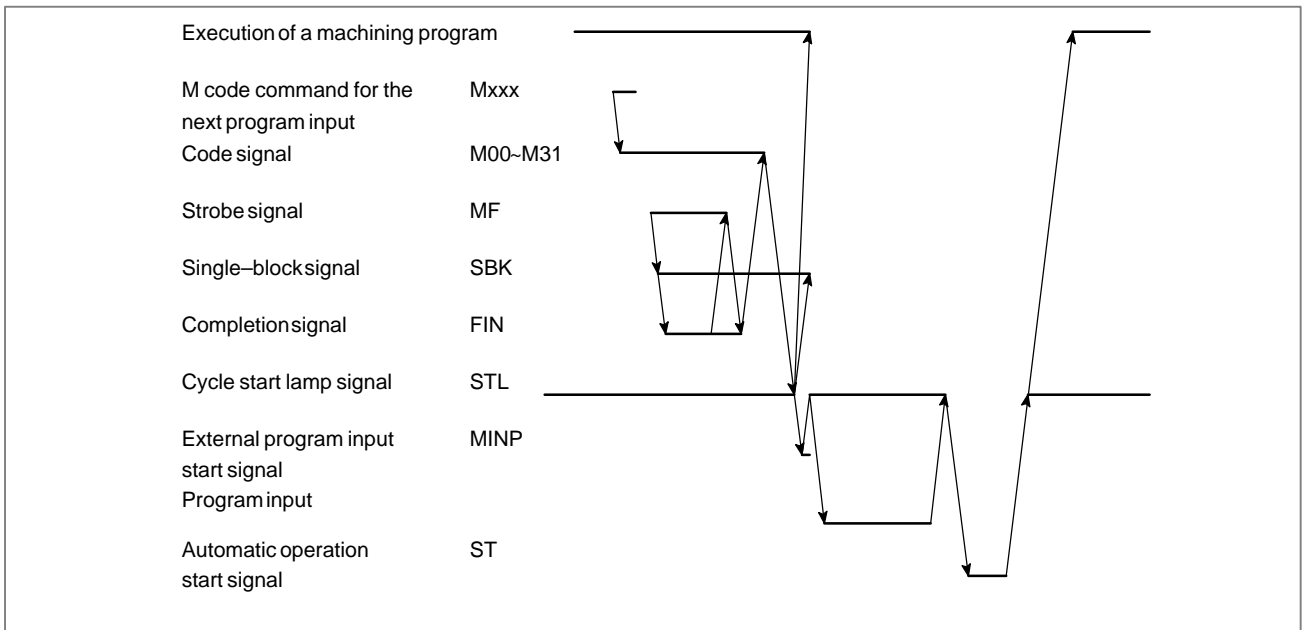

CAUTION
The M code used for input of the next program must not be buffered.

NOTE
While a program is being input, the automatic operation mode signal STL is set to 1. Upon termination of program input, STL is set to 0.

Signal Address

	#7	#6	#5	#4	#3	#2	#1	#0
G058								MINP

Parameter

	#7	#6	#5	#4	#3	#2	#1	#0
3201	MIP							

[Data type] Bit type

MIP Specifies whether to load a program into memory according to the external program input start signal (MINP).

0 : Does not load a program into memory.

1 : Loads a program into memory.

Note**NOTE**

- 1 A program can be input according to the external program input start signal only when the program has only one program number.
To read programs having multiple program numbers, reset the CNC each time the CNC reads one program. After reset, search for a desired program by using the workpiece number search signals, then input the program according to the external program input start signal.
- 2 When program input is activated by the external program input activation signal, all programs are deleted from the CNC, at the beginning.
- 3 In background editing, the external program input activation signal is ineffective.

13.8 DATA INPUT/OUTPUT FUNCTIONS BASED ON THE I/O Link

General

Power Mate programs, parameters, macro variables, and diagnostic (PMC) data are input/output through the FANUC I/O Link.

With the FANUC I/O Link, slaves from group 0 to group 15 can be connected, thus enabling data input/output to and from a maximum of 16 Power Mates.

When data input/output function B based on the I/O Link is used, the external I/O device control function is associated with an I/O Link to enable the specification of an input/output group number and program number from the PMC. The external I/O device control function operates in the background. This means that when no other background operation is being performed, data can be input/output, regardless of the CNC mode and the screen selected.

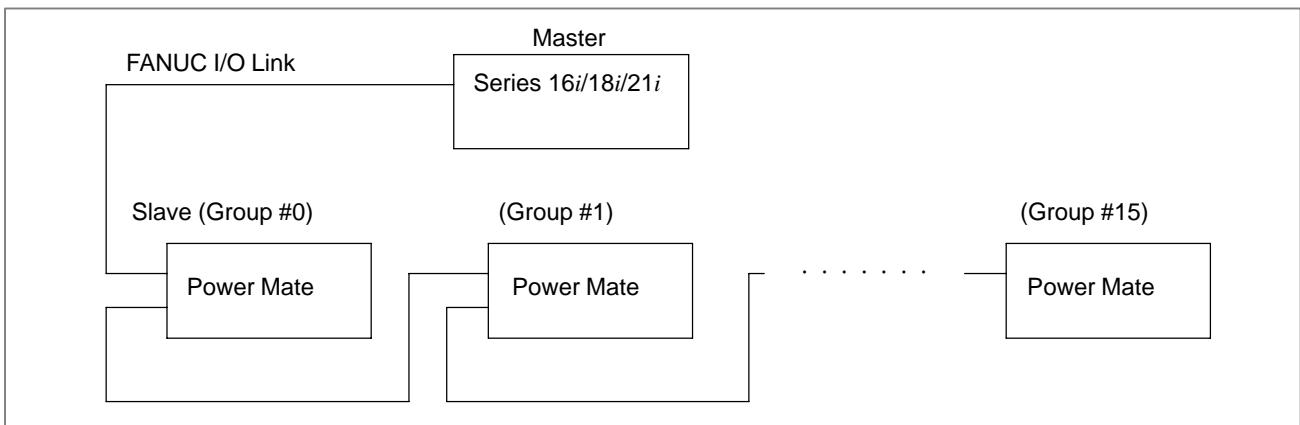

The programs, parameters, macro variables, and diagnostic (PMC) data of a slave Power Mate are stored in tape format within the part program storage length; these data items are stored as master program data in a master program memory area.

Data input/output can be performed between the master and the slave of a selected group. When the ordinary data input/output function based on the I/O Link is used, a group is selected by means of parameter setting. When data input/output function B based on the I/O Link is used, a group is selected by issuing the DI signal. Data input/output cannot be performed between the master and more than one group at a time.

For details of the Power Mate signals, refer to the following manuals.

Model	Manual name	Specification number
Power Mate-MODEL D/F	CONNECTION MANUAL	B-62833EN
Power Mate-MODEL E	CONNECTION • MAINTENANCE MANUAL	B-62115E
Power Mate <i>i</i> -MODEL D/H	CONNECTION MANUAL (FUNCTION)	B-63173EN-1



For details of the FANUC I/O Link, refer to the "FANUC PMC Programming Manual."

For details of the external I/O device control function, see Section 13.5.

• **Basic data input/output procedure**

(1) Program input/output

(a) Program input

- When the data input/output function based on the I/O Link is used
 - 1) Specify a number between 20 to 35 as the I/O channel on the setting screen to specify a group number.
 - 2) Specify EDIT mode.
 - 3) Display the program screen with function key .
 - 4) To change the program numbers, enter a new program number as follows:
 - (i) Select address O.
 - (ii) Key in the new program number.
 - 5) Using soft keys [(OPRT)], continuous-menu key , [READ], and [EXEC], read the program.
- When data input/output function B based on the I/O Link is used
 - 1) To read programs without changing the program numbers, specify -9999. To read programs by changing the program numbers, specify a desired number with the PMC function instruction (WINDW). A program number thus specified serves as the first program number when multiple programs are received. The second and any additional programs are numbered sequentially starting with the first number.
 - 2) Specify a desired group number with group number specification signals SRLNI0 to SRLNI3.
 - 3) Select an I/O Link by setting I/O Link specification signal IOLS to 1.
 - 4) When external punch start signal EXRD is set to 1, programs are read from the Power Mate.

NOTE

The user cannot read a program having an arbitrary program number registered in a Power Mate. All programs are always read from a Power Mate.

(b) Program output

- When the data input/output function based on the I/O Link is used
 - 1) Set a number between 20 and 35 as the I/O channel on the setting screen used to specify a group number.
 - 2) Set EDIT mode.
 - 3) Display the program screen by pressing the function key .

- 4) Select address O.
 - 5) Key in a program number.
 - 6) Using soft keys [(OPRT)], continuous-menu key , [PUNCH], and [EXEC], output the program corresponding to the keyed-in program number.
- When data input/output function B based on the I/O Link is used
 - 1) Using the PMC function instruction (WINDW), set the program number of the program to be output. Specify -9999 to output all programs.
 - 2) Specify a desired group number with group number specification signals SRLN10 to SRLN13.
 - 3) Select an I/O Link by setting the I/O Link specification signal IOLS to 1.
 - 4) When external punch start signal EXWT is set to 1, the program is output to the Power Mate.
- (2) Parameter input/output
- A Power Mate parameter in tape format is stored as a master-side NC program in a program memory area. The following program number is assigned to a Power Mate parameter of group n:
 $(\text{Value set in parameter No. 8760}) + n \times 10$
- (a) Parameter input
- When the data input/output function based on the I/O Link is used
In step 4) of program input (described in (1).(a)), key in a program number for a Power Mate parameter. The other steps are the same as those for program input.
 - When data input/output function B based on the I/O Link is used
In step 1) of program input (described in (1).(a)), specify a program number for the Power Mate parameters. The remaining steps are the same as those for program input.
- (b) Parameter output
- When the data input/output function based on the I/O Link is used
In step 5) of program output (described in (1).(b)), key in a program number for a Power Mate parameter. The other steps are the same as those for program output.
 - When data input/output function B based on the I/O Link is used
In step 1) of program output (described in (1).(b)), specify a program number for a Power Mate parameter. The remaining steps are the same as those for program output.
- (3) Macro variable input/output
- In the same way as for parameters, a Power Mate macro variable in tape format is stored as a master side NC program in a program memory area. The following program number is assigned to a Power Mate macro variable of group n:
 $(\text{Value set for parameter No. 8760}) + n \times 10 + 1$

(a) Macro variable input

- When the data input/output function based on the I/O Link is used
With Power Mate DI signals EDG00 to EDG15, specify a start number for the macro variables to be read. With EDN00 to EDN15, specify the number of macro variables to be read.
In step 4) of program input (described in (1).(a)), specify a program number for the Power Mate macro variables. The other steps are the same as those for program input.
- When data input/output function B based on the I/O Link is used
With Power Mate DI signals EDG00 to EDG15, specify a start number for the macro variables to be read. With EDN00 to EDN15, specify the number of macro variables to be read.
In step 1) of program input (described in (1).(a)), specify a program number for Power Mate macro variables. The remaining steps are the same as those for program input.

(b) Macro variable output

- When the data input/output function based on the I/O Link is used
In step 5) of program output (described in (1).(b)), specify a program number for a Power Mate macro variable. The other steps are the same as those for program output.
- When data input/output function B based on the I/O Link is used
In step 1) of program output (described in (1).(b)), specify a program number for a Power Mate macro variable. The remaining steps are the same as those for program output.

NOTE

The setting parameter or bit 1 (ISO) of parameter No. 0000 must be set to 1 to enable the use of the ISO code for macro variable output. When a macro variable is output in EIA code, the Power Mate issues alarm 001, while the Series 16i/18i/21i issues alarm 86.

(4) Diagnostic (PMC) data input/output

In the same way as the parameters and macro variables, a Power Mate diagnostic data item in tape format is stored as a master-side NC program in a program memory area. The following program number is assigned to a Power Mate diagnostic data item of group n: $(\text{Value set in parameter No. 8760}) + n \times 10 + 2$

(a) Diagnostic (PMC) data input

- When the data input/output function based on the I/O Link is used
With Power Mate DI signals EDG00 to EDG15, specify a start number for the diagnostic data items to be read. With EDN00 to EDN15, specify the number of diagnostic data items to be read.
In step 4) of program input (described in (1).(a)), specify a program number for the Power Mate diagnostic data items. The other steps are the same as those for program input.
- When data input/output function B based on the I/O Link is used
With Power Mate DI signals EDG00 to EDG15, specify a start number for the diagnostic data items to be read. With EDN00 to EDN15, set the number of diagnostic data items to be read.
In step 1) of program input (described in (1).(a)), specify a program number for Power Mate diagnostic data items. The remaining steps are the same as those for program input.

(b) Diagnostic (PMC) data output

- When the data input/output function based on the I/O Link is used
In step 5) of program output (described in (1).(b)), specify a program number for a Power Mate diagnostic data item. The other steps are the same as those for program output.
- When data input/output function B based on the I/O Link is used
In step 1) of program output (described in (1).(b)), specify a program number for a Power Mate diagnostic data item. The remaining steps are the same as those for program output.

NOTE

The addresses of Power Mate DI signals EDG00 to EDG15 and EDN00 to EDN15 differ depending on the model of the Power Mate as listed in the table below. For macro variable and diagnostic data input, ensure that these signals are processed correctly. If an invalid value or number is set, the Power Mate's external I/O device control function is not started.

Signal name	Power Mate A/B/C/E	Power Mate D/F Power Mate i-D/H
EDG00 to EDG07 EDG08 to EDG15	G100.0 to G100.7 G101.0 to G101.7	G252.0 to G252.7 G253.0 to G253.7
EDN00 to EDN07 EDN08 to EDN15	G102.0 to G102.7 G103.0 to G103.7	G254.0 to G254.7 G255.0 to G255.7

● **Stopping input/output**

There are two methods of forcibly terminating input/output.

(1) Termination by a reset

Input/output can be terminated by a reset. In this case, however, slave read/write stop signal ESTPIO is not output. Therefore, the operation of the Power Mate is not terminated even if the Power Mate is performing input/output. To terminate Power Mate operation, create a ladder program so that ESTPIO is set to 1 upon the occurrence of a reset.

(2) Termination using external read/punch stop signal EXSTP (applicable only when data input/output function B based on the I/O Link is used)

Input/output can be terminated by setting external read/punch stop signal EXSTP to 1. In this case, slave read/write stop signal ESTPIO is output, and all processing is terminated once the termination of Power Mate input/output has been confirmed. See the timing chart for the case where the Series 16i/18i/21i issues an alarm.

● **Specifying the PMC functions**

The PMC function instruction (WINDW) is used to set the program numbers used with data input/output function B based on the I/O Link.

[Data] This function is a window function for specifying the program numbers used to perform program input/output with the I/O device control function via the I/O Link.

[Input data structure]

Top address +0 +2 +4 +6 +8 +10

Function code	Completion code	Data length	Data number	Data attribute	Data
194	–	2	0	0	Program number

(‘–’ : Need not be set.)

Specify 0 in the data number and data attribute fields.

Specify 2 in the data length field.

Specify a desired two-byte program number (1 to 9999, –9999) in the data field.

[Output data structure]

Top address +0 +2 +4 +6 +8 +10

Function code	Completion code	Data length	Data number	Data attribute	Data
194	?	Input data	Input data	Input data	Input data

[Completion codes]

0 : Normal termination

5 : Data other than 1 to 9999 or –9999 was specified.

The data length, data number, and data attribute fields are not checked. For details of the PMC function instructions, refer to the “FANUC PMC Programming Manual.”

- **Power Mate state signals (input)**

When the data input/output function based on the I/O Link is used, the state signals for a specified Power Mate must be reported to the CNC. These signals must be posted to the Series 16i/18i/21i via the following path:

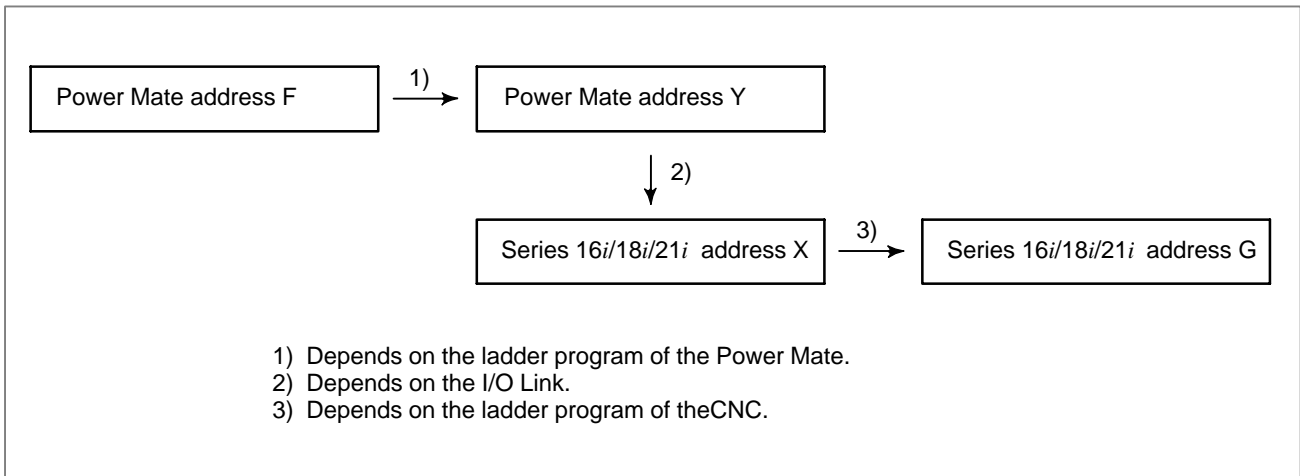

For an explanation of the functions of the Power Mate state signals, see item Signal.

- **Power Mate control signals (output)**

When the data input/output function based on the I/O Link is used, Power Mate control signals must be output from the CNC to control the external I/O device control function of a specified Power Mate. These signals must be posted to the Power Mate via the following path:

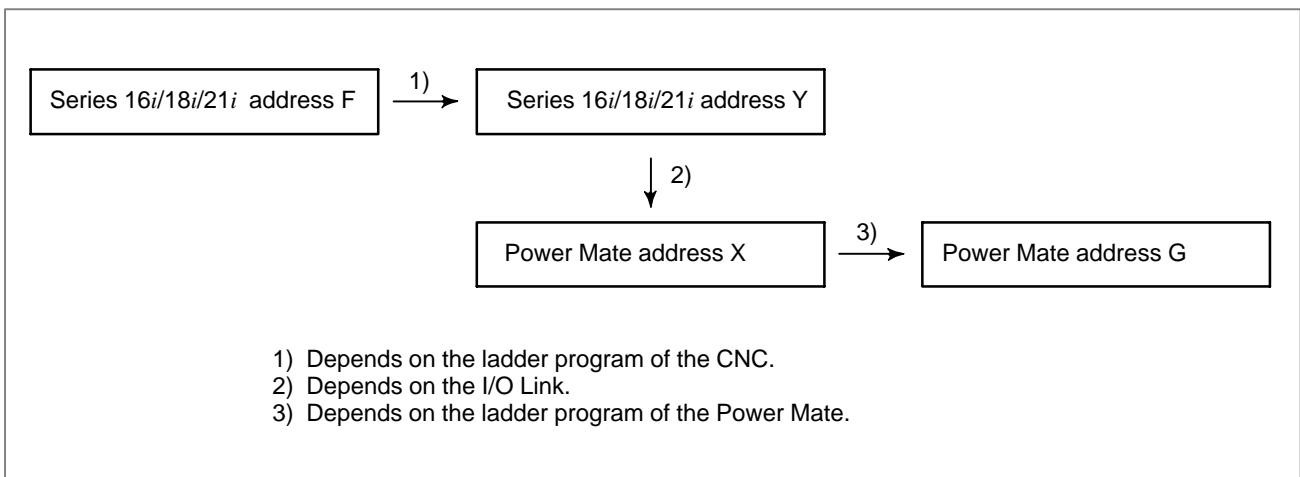

For an explanation of the functions of the Power Mate control signals, see item Signal.

- **DI/DO signal timing charts**

The DI/DO signal timing charts applicable when data input/output function B based on the I/O Link is used are shown below. When the ordinary data input/output function based on the I/O Link is used, 1) through 4) in the figures are subject to MDI-based input/output.

- (1) When ordinary input/output is performed
 - 1) Specify a program number with the PMC function instruction (WINDW).
 - 2) Specify the group number of the Power Mate to be used for input/output with group number specification signals SRLNI0 to SRLNI3.
 - 3) Set I/O Link specification signal IOLS to 1.
 - 4) For input, set external read start signal EXRD to 1.
For output, set external punch start signal EXWT to 1.
 - 5) Processing by the CNC outputs slave I/O Link selection signal IOLNK and group number output signals SRLNO0 to SRLNO3.
 - 6) Using a ladder program, make the necessary preparations for data input/output using the I/O Link.
 - 7) Upon the completion of step 6), set the I/O Link confirmation signal IOLACK to 1. The CNC waits until IOLACK is set to 1.
 - 8) The CNC outputs slave external read/write signal ERDIO/EWTIO, and slave input/output data selection signals EPRG, EVAR, EPARM, and EDGN.
 - 9) The CNC waits for the external I/O device control function of the Power Mate to start. (The CNC waits for the external I/O device control function of the Power Mate to start.)
 - 10) The CNC performs data input/output through the I/O Link.
 - 11) Upon the completion of data input/output, the CNC sets the slave external read/write start signal and slave input/output data selection signals to 0.
 - 12) The CNC waits for the completion of the external I/O device control function of the Power Mate. The CNC waits for termination or completion of the external I/O device control function of the Power Mate.
 - 13) Upon the completion of the operation of the external I/O device control function of the Power Mate, the Power Mate read/write in-progress signal BGION is set to 0.
 - 14) The CNC sets the slave I/O Link selection signal IOLNK to 0.
 - 15) I/O Link specification signal IOLS and I/O Link confirmation signal IOLACK are set to 0.

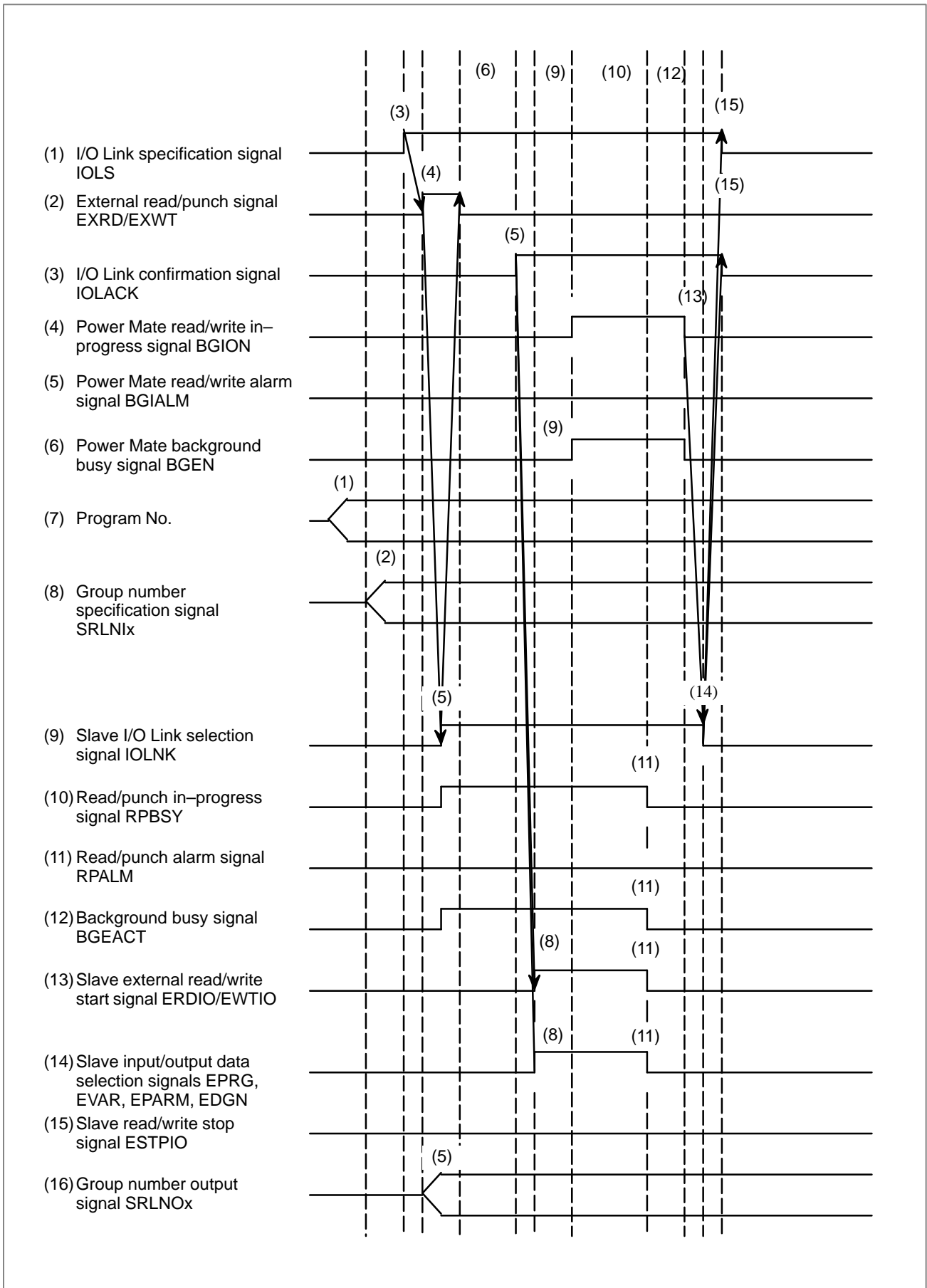

- (2) When an alarm is issued by the CNC (including the case where processing is stopped by external read/punch signal EXSTP)

Steps 1) to 10) are the same as those for ordinary input/output.

- 11) When the CNC issues an alarm, or when external read/punch stop signal EXSTP is set to 1, slave read/write stop signal ESTPIO is set to 1.
- 12) The CNC waits for the external I/O device control function of the Power Mate to terminate. The CNC merely waits until the external I/O device control function of the Power Mate terminates.
- 13) When the external I/O device control function of the Power Mate terminates, Power Mate read/write in-progress signal BGION is set to 0.
- 14) The CNC sets slave I/O Link selection signal IOLNK and slave read/write stop signal ESTPIO to 0.
- 15) I/O Link specification signal IOLS and I/O Link confirmation signal IOLACK are set to 0.

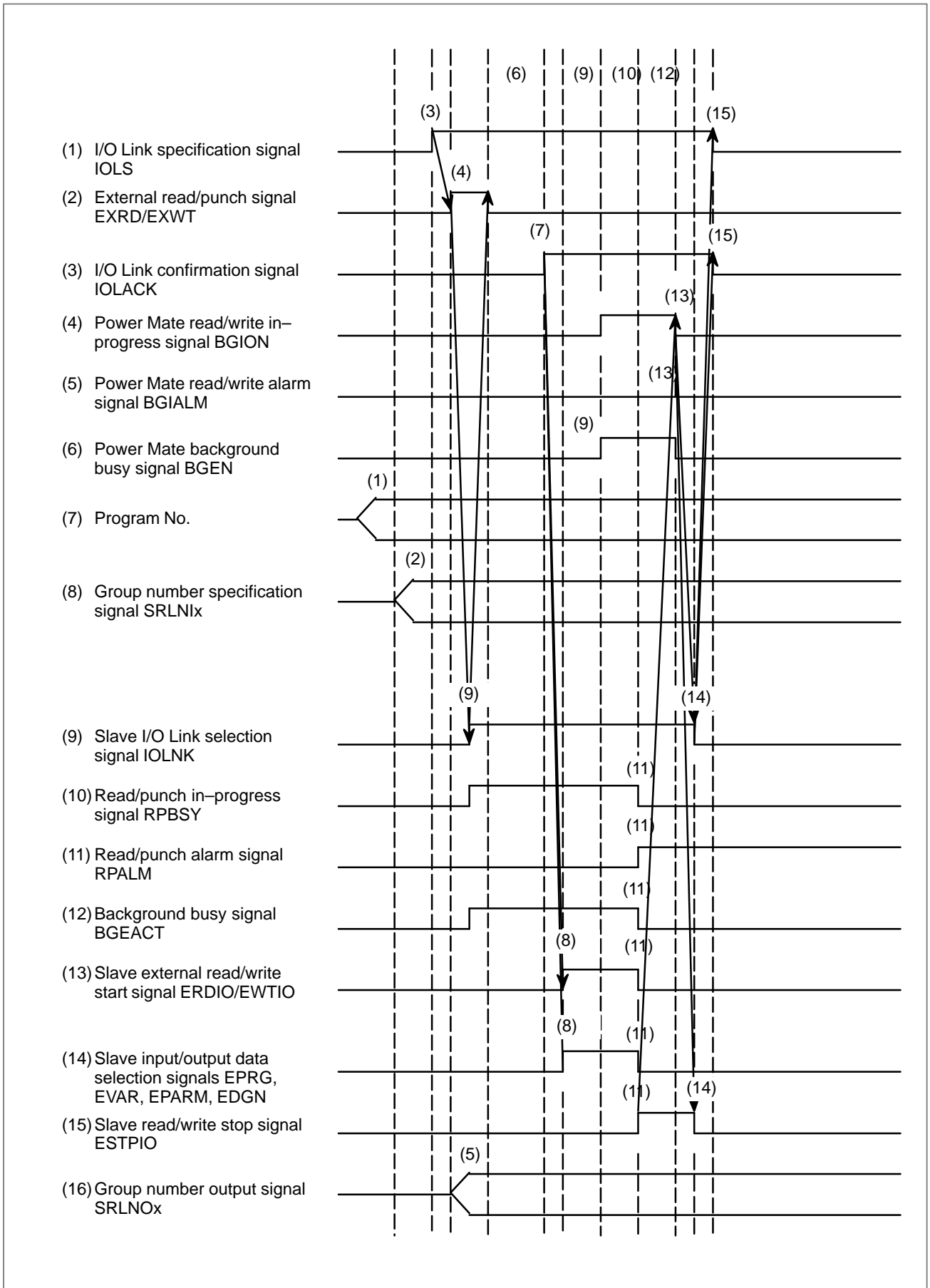

(3) When an alarm is issued by the Power Mate

Steps 1) to 10) are the same as those for ordinary input/output.

- 11) When the Power Mate issues an alarm, Power Mate read/write alarm signal BGIALM is set to 1, and Power Mate read/write in-progress signal BGION is set to 0.
- 12) The CNC sets slave I/O Link selection signal IOLNK and slave read/write stop signal ESTPIO to 0.
- 13) I/O Link specification signal IOLS and I/O Link confirmation signal IOLACK are set to 0.

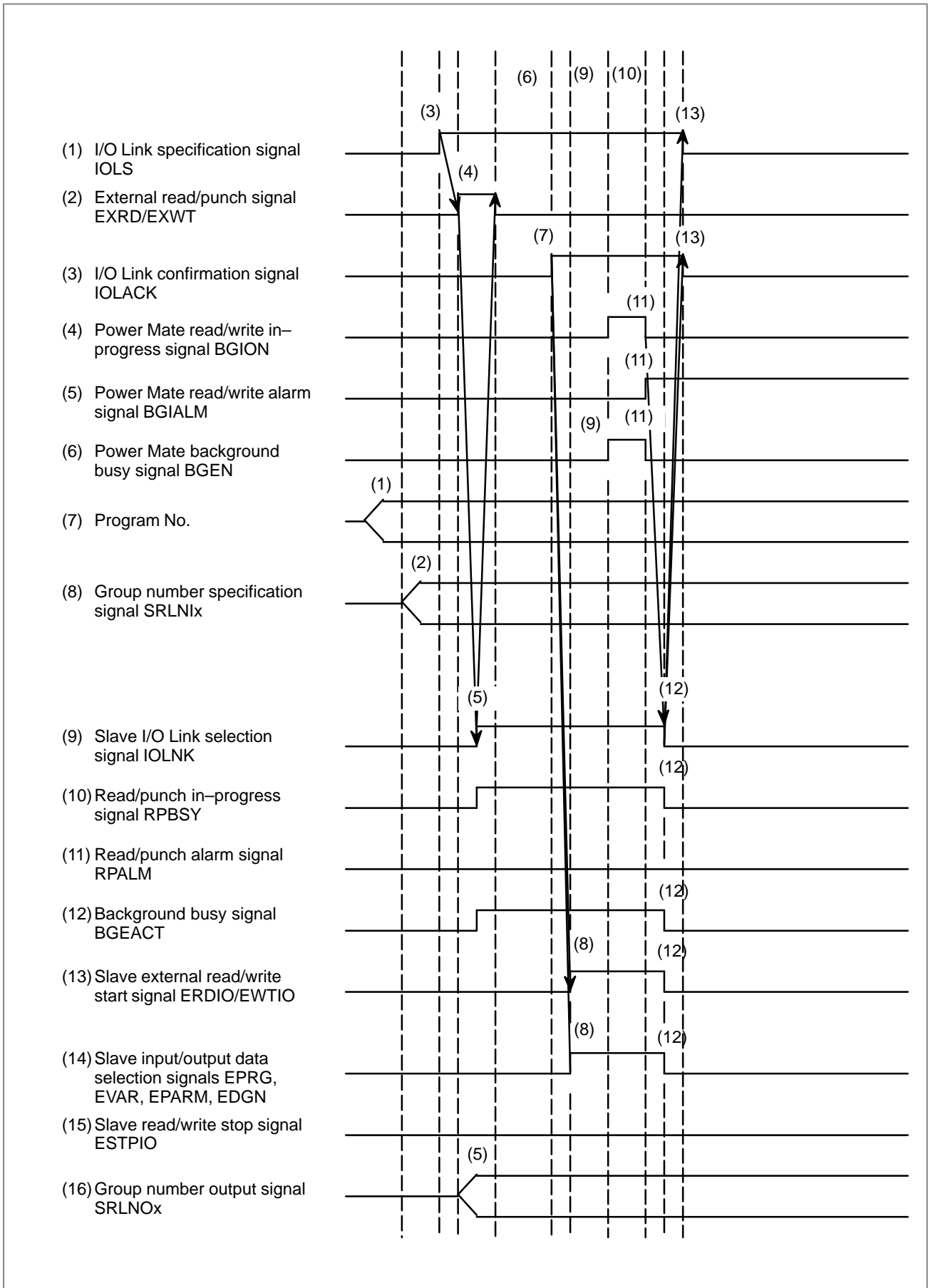

● Troubleshooting

The data input/output function based on the FANUC I/O Link is implemented by various elements such as ladder programs, I/O Link assignment, CNC parameters, and Power Mate parameters. So, problems may occur when the function is started.

The table below lists the symptoms of the problems that may occur, together with their causes and corresponding corrective actions.

Symptom	Cause and corrective action
Data input/output is started, but the CNC and Power Mate return no response.	The background is already active (the background busy signal BGEACT is set to 1). In this case, the function cannot be used. Examples: 1) In MDI mode, the program screen is selected. 2) Background editing has already started.
	Communication via the RS-232-C interface is in progress. Multiple communication operations cannot be performed at the same time, such that any subsequent attempt to start the function is ignored.
	The selected slave is not a Power Mate. Data input/output function B based on the I/O Link is not started if the slave specified with a group number set with group number specification signals SRLN10 to SRLN13 is other than a Power Mate.
	A ladder program error may prevent the function from being started. Check the ladder program for errors such as mis-specified addresses.
When an attempt is made to output data to a Power Mate: CNC: OUTPUT blinks continuously. Power Mate : LSK blinks continuously . (Caution)	Power Mate DO signal RPBSY is not correctly passed to Power Mate read/write in-progress signal RPBSY of the CNC.

Symptom	Cause and corrective action
<p>When an attempt is made to output data to a Power Mate:</p> <p>CNC: OUTPUT blinks continuously.</p> <p>Power Mate : No response is returned. (Caution)</p>	<p>I/O Link confirmation signal IOLACK is not set to 1.</p> <p>A ladder program error, I/O Link assignment error may prevent.</p>
<p>When an attempt is made to read data from a Power Mate:</p> <p>CNC: LSK blinks continuously.</p> <p>Power Mate: No response is returned. (Caution)</p>	
<p>When an attempt is made to output parameters to a Power Mate:</p> <p>CNC: OUTPUT blinks continuously.</p> <p>Power Mate: No response is returned. (Caution)</p>	<p>PWE of the Power Mate is set to 0.</p> <p>To modify the Power Mate parameters, PWE must be set to 1.</p> <p style="text-align: right;">(Caution)</p>
<p>When an attempt is made to output diagnostic data to a Power Mate:</p> <p>CNC: OUTPUT blinks continuously.</p> <p>Power Mate : No response is returned. (Caution)</p>	<p>DWE of the Power Mate is set to 0.</p> <p>To enable the modification of Power Mate diagnostic data, DWE must be set to 1.</p> <p style="text-align: right;">(Caution)</p>
<p>When an attempt is made to output macro variables to a Power Mate:</p> <p>CNC: Alarm 86 is issued.</p> <p>Power Mate : Alarm 1 is issued.</p>	<p>Bit 1 (ISO) of parameter No. 0000 is set to 1 (EIA code).</p> <p>The EIA code does not include #, such that an ISO code must be set.</p>
<p>When an attempt is made to read macro variables or diagnostic data from a Power Mate:</p> <p>CNC: LSK blinks continuously.</p> <p>Power Mate : No response is returned. (Caution)</p>	<p>A start number and the number of data items to be transferred are not set correctly in Power Mate DI signals G100 to G103 and G252 to G255.</p> <p>Examples:</p> <ol style="list-style-type: none"> 1 A ladder program error or I/O allocation error prevented a start number and the number of data items from being transferred to Power Mate DI signals G100 to G103 and G252 to G255. 2 An invalid start number is specified, or the specified number of data items to be transferred is invalid.

CAUTION

If these symptoms are detected, the CNC waits for a condition to be satisfied in its internal processing. While such a state exists, the screen is not updated. So, the states of signals cannot be checked on a real-time basis on a screen such as the PMC diagnostic screen.

Signal
**Power Mate read/write
in-progress signal
BGION <G092#2>**

[Classification] Input signal

[Function] This signal indicates that the Power Mate is performing data input/output.

[Operation] This signal is set to 1 when the Power Mate is performing data input/output.

This signal is a Power Mate state signal. The corresponding Power Mate side signal is RPBSY <F223#2/F053#2>.

(The former address is for Power Mate A/B/C/E and the latter address is for Power Mate D/H/i-D/i-H.)

**Power Mate read/write
alarm signal
BGIALM <G092#3>**

[Classification] Input signal

[Function] This signal indicates that an alarm has been issued while the Power Mate was performing data input/output.

[Operation] This signal is set to 1 upon the issue of an alarm while the Power Mate is performing data input/output.

This signal is a Power Mate state signal. The corresponding Power Mate side signal is RPALM <F223#3/F053#3>.

(The former address is for Power Mate A/B/C/E and the latter address is for Power Mate D/H/i-D/i-H.)

**Power Mate background
busy signal
BGEN <G092#4>**

[Classification] Input signal

[Function] This signal indicates that the Power Mate is performing background editing.

[Operation] This signal is set to 1 when the Power Mate is performing background editing.

This signal is a Power Mate state signal. The corresponding Power Mate side signal is BGEACT <F223#4/F053#4>.

(The former address is for Power Mate A/B/C/E and the latter address is for Power Mate D/H/i-D/i-H.)

I/O Link confirmation signal

IOLACK <G092#0>

[Classification] Input signal

[Function] This signal indicates that the Power Mate state signals are valid.

[Operation] When this signal is set to 1, the control unit operates as follows:

- All Power Mate state signals become valid.

For data input/output between the CNC and Power Mate, the Power Mate state signals are used. For this purpose, ladder program processing is required. Upon the completion of ladder program processing, I/O Link confirmation signal IOLACK is set to 1 to make the Power Mate state signals active.

I/O Link specification signal

IOLS <G092#1>

[Classification] Input signal

[Function] This signal specifies whether those signals that are shared by the external I/O device control function are to be used with data input/output function B based on the I/O Link.

[Operation] When this signal is set to 1, the control unit operates as follows:

- The signals (EXRD, EXSTP, EXWT, RPBSY, RPALM, and BGEACT) for the external I/O device control function are used with data input/output function B based on the I/O Link.

NOTE

I/O Link specification signal IOLS is not used with the ordinary data input/output function based on the I/O Link.

Group number specification signals

SRLNI0 to SRLNI3

<G091#0 to #3>

[Classification] Input signal

[Function] These signals specify the group number of the Power Mate that acts as a slave when data input/output function B based on the I/O Link is used.

[Operation] The group number of the Power Mate that acts as a slave is specified with the values of four digits binary code signals.

NOTE

Group number specification signals SRLNI0 to SRLNI3 are not used with the ordinary data input/output function based on the I/O Link.

Slave I/O Link selection signal

IOLNK <F177#0>

[Classification] Output signal

[Function] This signal instructs the Power Mate to perform data input/output based on the I/O Link.

[Output condition] This signal is set to 1 in the following case:

– When data input/output is performed

This signal is set to 0 in the following case:

– When data input/output is terminated

This signal is a Power Mate control signal. The corresponding Power Mate side signal is IOLNK <G099#7/G251#0>.

(The former address is for Power Mate A/B/C/E and the latter address is for Power Mate D/H/i–D/i–H.)

Slave external read start signal

ERDIO <F177#1>

[Classification] Output signal

[Function] This signal indicates that the CNC has started data output.

[Output condition] This signal is set to 1 in the following case:

– When data output is started

This signal is set to 0 in the following case:

– When data output is terminated

This signal is a Power Mate control signal. The corresponding Power Mate side signal is EXRD <G098#1/G058#1>.

(The former address is for Power Mate A/B/C/E and the latter address is for Power Mate D/H/i–D/i–H.)

Slave read/write stop signal

ESTPIO <F177#2>

[Classification] Output signal

[Function] This signal forcibly terminates Power Mate data input/output.

[Output condition] This signal is set to 1 in the following cases:

– When the CNC issues an alarm

– When data input/output function B based on the I/O Link is used, and external read/punch stop signal EXSTP is set to 1

This signal is set to 0 in the following case:

–When data input/output is terminated

This signal is a Power Mate control signal. The corresponding Power Mate side signal is EXSTP <G098#2/G058#2>.

(The former address is for Power Mate A/B/C/E and the latter address is for Power Mate D/H/i–D/i–H.)

**Slave external write start
signal
EWTIO <F177#3>**

[Classification] Output signal

[Function] This signal indicates that the CNC has started data input.

[Output condition] This signal is set to 1 in the following case:

– When data input is started

This signal is set to 0 in the following case:

– When data input is terminated

This signal is a Power Mate control signal. The corresponding Power Mate side signal is EXWT <G098#3/G058#3>.

(The former address is for Power Mate A/B/C/E and the latter address is for Power Mate D/H/i-D/i-H.)

**Slave program selection
signal
EPRG <F177#4>**

[Classification] Output signal

[Function] This signal notifies the Power Mate that the input/output data consists of programs.

[Output condition] This signal is set to 1 in the following case:

– When the input/output data consists of programs, and data input/output has been started

This signal is set to 0 in the following case:

– When data input/output is terminated

This signal is a Power Mate control signal. The corresponding Power Mate side signal is EPRG <G098#4/G251#4>.

(The former address is for Power Mate A/B/C/E and the latter address is for Power Mate D/H/i-D/i-H.)

**Slave macro variable
selection signal
EVAR <F177#5>**

[Classification] Output signal

[Function] This signal notifies the Power Mate that the input/output data consists of macro variables.

[Output condition] This signal is set to 1 in the following case:

– When the input/output data consists of macro variables, and data input/output has been started

This signal is set to 0 in the following case:

- When data input/output is terminated

This signal is a Power Mate control signal. The corresponding Power Mate side signal is EVAR <G098#5/G251#5>.

(The former address is for Power Mate A/B/C/E and the latter address is for Power Mate D/H/i–D/i–H.)

Slave parameter selection signal EPARM <F177#6>

[Classification] Output signal

[Function] This signal notifies the Power Mate that the input/output data consists of parameters.

[Output condition] This signal is set to 1 in the following case:

- When the input/output data consists of parameters, and data input/output has been started

This signal is set to 0 in the following case:

- When data input/output is terminated

This signal is a Power Mate control signal. The corresponding Power Mate side signal is EPARM <G098#6/G251#6>.

(The former address is for Power Mate A/B/C/E and the latter address is for Power Mate D/H/i–D/i–H.)

Slave diagnostic data selection signal EDGN <F177#7>

[Classification] Output signal

[Function] This signal notifies the Power Mate that input/output data consists of diagnostic (PMC) data.

[Output condition] This signal is set to 1 in the following case:

- When input/output data consists of diagnostic (PMC) data, and data input/output has been started

This signal is set to 0 in the following case:

- When data input/output is terminated

This signal is a Power Mate control signal. The corresponding Power Mate side signal is EDGN <G098#7/G251#7>.

(The former address is for Power Mate A/B/C/E and the latter address is for Power Mate D/H/i–D/i–H.)

**Group number output
signals
SRLNO0 to SRLNO3
<F178#0 to #3>**

[Classification] Output signal

[Function] These signals indicate the group number of the Power Mate that is acting as a slave.

[Operation] The group number of the Power Mate that is acting as a slave is specified with the values of four binary code signals. These signals become active when the slave I/O Link selection signal IOLNK is set to 1.

The signals listed below are used with data input/output function B based on the I/O Link. For details, see Section 13.5.

**External read start signal
EXRD <G058#1>**

**External punch start
signal
EXWT <G058#3>**

**External read/punch stop
signal
EXSTP <G058#2>**

**Background busy signal
BGEACT <F053#4>**

**Read/punch in-progress
signal
RPBSY <F053#2>**

**Read/punch alarm signal
RPALM <F053#3>**

Signal address

G058	#7	#6	#5	#4	#3	#2	#1	#0
					EXWT	EXSTP	EXRD	
G091	#7	#6	#5	#4	#3	#2	#1	#0
					SRLNI3	SRLNI2	SRLNI1	SRLNI0
G092	#7	#6	#5	#4	#3	#2	#1	#0
				BGEN	BGIALM	BGION	IOLS	IOLACK
F053	#7	#6	#5	#4	#3	#2	#1	#0
				BGEACT	RPALM	RPBSY		
F177	#7	#6	#5	#4	#3	#2	#1	#0
	EDGN	EPARM	EVAR	EPRG	EWLIO	ESTPIO	ERDIO	IOLINK
F178	#7	#6	#5	#4	#3	#2	#1	#0
					SRLNO3	SRLNO2	SRLNO1	SRLNO0

Parameter

0020	I/O CHANNEL: Selection of an input/output device
------	--

Setting entry is acceptable.

[Data type] Byte

[Valid data range] 0 to 35

This CNC provides the following interfaces for data transfer to and from the host computer and external input/output devices:

- Input/output device interface (RS-232-C serial port 1, 2)
- Remote buffer interface (RS-232-C/RS-422)
- DNC1/DNC2 interface

In addition, data can be transferred to and from the Power Mate via the FANUC I/O Link. (This parameter need not be set when data input/output function B based on the I/O Link is used.)

This parameter is used to select the interface used to transfer data to and from an input/output device.

Setting	Description							
0, 1	RS-232-C serial port (connector JD36A on motherboard)							
2	RS-232-C serial port (connector JD36B on motherboard)							
3	Remote buffer interface (connector JD28A (RS-232-C interface) or connector JD6A (RS-422 interface) on serial communication board)							
4	Memory card interface							
5	Data server interface							
10	DNC1/DNC2 interface, OSI-Ethernet							
11	DNC1 interface #2							
20 21 22 34 35	<table border="0"> <tr> <td>Group 0</td> <td rowspan="6">} Data is transferred between the CNC and Power Mate in group n (n: 0 to 15) via the FANUC I/O Link.</td> </tr> <tr> <td>Group 1</td> </tr> <tr> <td>Group 2</td> </tr> <tr> <td> </td> </tr> <tr> <td>Group 14</td> </tr> <tr> <td>Group 15</td> </tr> </table>	Group 0	} Data is transferred between the CNC and Power Mate in group n (n: 0 to 15) via the FANUC I/O Link.	Group 1	Group 2		Group 14	Group 15
Group 0	} Data is transferred between the CNC and Power Mate in group n (n: 0 to 15) via the FANUC I/O Link.							
Group 1								
Group 2								
Group 14								
Group 15								

NOTE

An input/output device can also be selected using the setting screen. Usually the setting screen is used.

8760

Program number for data registration (data input/output function using the I/O link)

[Data type] Word**[Valid data range]** 0 to 9999

When the data input/output function using the I/O link is used, this parameter sets the program numbers of the programs to be used for registering data (parameters, macro variables, and diagnostic data) from Power Mates.

For a Power Mate in group n, the following program numbers are used:

For parameters: $\text{Setting} + n \times 10 + 0$

For macro variables: $\text{Setting} + n \times 10 + 1$

For diagnostic data: $\text{Setting} + n \times 10 + 2$

Example: When 8000 is set

8000: Parameters of group 0 (I/O channel = 20)

8001: Macro variables of group 0 (I/O channel = 20)

8002: Diagnostic data of group 0 (I/O channel = 20)

8010: Parameters of group 1 (I/O channel = 21)

8011: Macro variables of group 1 (I/O channel = 21)

8012: Diagnostic data of group 1 (I/O channel = 21)

8020: Parameters of group 2 (I/O channel = 22)

8021: Macro variables of group 2 (I/O channel = 22)

8022: Diagnostic data of group 2 (I/O channel = 22)

8150: Parameters of group 15 (I/O channel = 35)

8151: Macro variables of group 15 (I/O channel = 35)

8152: Diagnostic data of group 15 (I/O channel = 35)

NOTE

When 0 is set, the input/output of parameters, macro variables, and diagnostic data cannot be performed, but program input/output processing is performed.

Alarm and message

Number	Message	Description
085	COMMUNICATION ERROR	When entering data in the memory by using Reader / Puncher interface, or FANUC I/O Link an overrun, parity or framing error was generated. The number of bits of input data or setting of baud rate or specification No. of I/O unit is incorrect.
086	DR SIGNAL OFF	When entering data in the memory by using Reader / Puncher interface, the ready signal (DR) of reader / puncher was off. Power supply of I/O unit is off or cable is not connected or a P.C.B. is defective. Or, the slave is not ready to perform data input/output (or the slave is performing background editing) if this alarm is issued when data input/output using the FANUC I/O Link is started. Alternatively, slave-side input/output is stopped (with alarm output) if this alarm is issued during input/output.
087	BUFFER OVERFLOW	When entering data in the memory by using Reader / Puncher interface, though the read terminate command is specified, input is not interrupted after 10 characters read. I/O unit or P.C.B. is defective. Alternatively, for data read using the FANUC I/O Link, the master directs the termination of a read operation, but the slave does not stop output.

13.9 SCREEN HARD COPY FUNCTION

General

When the display control card has a graphic function, screen information displayed on the CNC can be converted to 640-by-480-dot bit-mapped data and output to a memory card. Then, the created bit map data can be displayed on a personal computer.

Operation

The screen hard copy function is activated by setting the hard copy start signal HDREQ (G67#7) to 1 or by holding down the [SHIFT] key for five seconds. The function is stopped by pressing the [CAN] key or by setting the hard copy stop signal HDABT (G67#6) to 1.

During screen hard copy operation, the hard copy in-progress signal (F061#3) is held 1, and the screen is kept in the static state for several tens of seconds (several seconds for a monochrome LCD) until hard copy operation terminates. Upon completion of screen hard copy operation, the hard copy in-progress signal (F061#3) is set to 0.

The number of colors used in created bit-mapped data depends on the display control card, LCD hardware, and display mode of the CNC display screen. The relationship is shown in Table 13.9 (a).

Table 13.9 (a) Number of colors in the BMP data created by screen hard copy operation

	LCD hardware	CNC screen display mode	Number of colors displayed in CNC	Number of colors in created BMP data	Remarks
V G A c a r d	Monochrome LCD	—	2 colors	2 colors	The monochrome tone is not supported.
	Color LCD	VGA compatible mode	Character: 16 colors Graphics: 16 colors	When bit 0 of parameter No. 3301 is 0: 256 colors When bit 0 of parameter No. 3301 is 1: 16 colors	Most normal CNC screens are in this mode. Note that in 16-color mode, colors cannot sometimes be displayed normally.
		VGA mode	256 colors	256 colors	Screens in this mode can be prepared specifically using the C executor and so on.

The following names are assigned sequentially to files of bit-mapped data created by the first and subsequent screen hard copy operations since power-up:

'HDCPY000.BMP' (Data name assigned by the first hard copy operation since power-up)

'HDCPY001.BMP' (Data name assigned by the second hard copy operation since power-up)

⋮

'HDCPY099.BMP'

After HDCPY099.BMP is output, executing another screen hard copy operation outputs HDCPY000.BMP. Note that, however, when a file having the same name as that of the BMP data to be output by screen hard copy operation is already present on the memory card, the file is overwritten unconditionally.

With the screen hard copy function, a hard copy of a static image screen displayed on the CNC can be created. Hard copy operation is possible in all operation modes.

Hard copy operation for those screens that meet the restriction conditions described on page XX, however, cannot be performed.

Table 13.9 (b) shows the sizes of bit-mapped data created by screen hard copy operation.

Table 13.9 (b) Size of bit-mapped data created by screen hard copy

Number of colors in bit map	File size [in bytes]
Monochrome (2 colors)	38,462
Color (16 colors)	153,718
Color (256 colors)	308,278

CAUTION

- 1 During screen hard copy operation, key input is disabled for several tens of seconds, and the screen is held in the static state until the hard copy operation terminates. During this period, except the hard copy in-progress signal (F061#3) that is set to 1, nothing is output. So, do not turn off the power, carelessly regarding this status as faulty.
- 2 When the [SHIFT] or [CAN] key is customized with the C executor and so on, the [SHIFT] or [CAN] key is sometimes disabled in screen hard copy operation.
- 3 Taking a hard copy of a C executor screen requires longer time than indicated in Table 2.
- 4 Unless the screen is in the static state, it is difficult to take a hard copy normally. So, when taking a screen hard copy, be sure to place the screen in the static state.
- 5 When hard copy operation is performed after the power is turned off then on again, file name HDCPY000.BMP is assigned. In this case, if the same file name is present on the memory card, the existing data is overwritten unconditionally, so care should be taken.

Restriction

- This function cannot be used in the following case:
 - 160i/180i/210i/160is/180is/210is
 - Construction of connecting with PC via HSSB and not attaching MDI to the CNC side
- Hard copies of system alarm screens cannot be taken.
- When RS-232C is being used, hard copy operation cannot be performed.
- During automatic operation (or manual operation), hard copy operation cannot be performed. Hard copy operation, however, can be performed in the stopped state.

Alarm and message

When bit 2 (HCALM) of parameter No. 3301 is set to 1, the CNC can issue an alarm message if hard copy execution fails. Table 13.9 (c) lists the alarm messages, their meanings, and responses.

Table 13.9 (c) Alarm messages related to the screen hard copy function

Number	Message	Description
5212	SCREEN COPY: PARAMETER ERROR	An obviously illegal parameter setting is found. Check that the I/O channel is set to 4.
5213	SCREEN COPY: COMMUNICATION ERROR	The right to exclusively use the memory card cannot be obtained. The memory card is abnormal or write-protected.
5214	SCREEN COPY: DATA TRANSFER ERROR	Data transfer to the memory card failed. The memory card may have been removed during hard copy operation. Alternatively, the available area on the memory card becomes 0.

Signal

Hard copy request signal HCREQ <G067#7>

[Classification] Input signal

[Function] This signal requests the CNC to execute hard copy operation.

[Operation] When this signal is set to 1, the CNC operates as follows:

- Starts hard copy operation.

Hard copy stop request signal HCABT <G067#6>

[Classification] Input signal

[Function] This signal requests the CNC to stop hard copy operation.

[Operation] When this signal is set to 1, the CNC operates as follows:

- Stops hard copy operation.

Hard copy in-progress signal HCEXE <F061#3>

[Classification] Output signal

[Function] This signal reports that hard copy operation is in progress.

[Output condition] This signal is set to 1 when:

- The hard copy execution state has been entered by setting G067#7 (HDCPY) to 1, by holding down the [SHIFT] key for 4.8 seconds, and so forth.

The signal is set to 0 when:

- The hard copy execution state is released because hard copy operation is completed or canceled.

Hard copy stop request acceptance flag HCAB2 <F061#2>

[Classification] Output signal

[Function] This signal reports that a request to stop hard copy operation is made.

[Output condition] This signal is set to 1 when:

- G063#6 (HCABT) is set to 1, or a hard copy stop command is issued by, for example, pressing the [CAN] key.

The signal is set to 0 when:

- The reset key is pressed.
- Another hard copy operation starts.

Time charts of the input and output signals are shown below. Fig. 13.9 (a) is a time chart of normal termination of hard copy operation, and Fig. 13.9 (b) is a time chart of forced termination of hard copy operation.

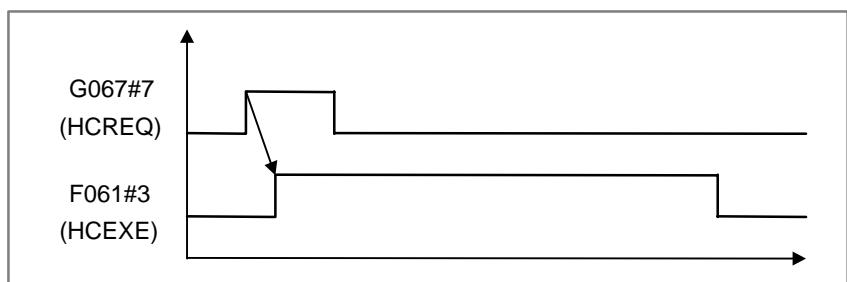

Fig. 13.9 (a) Time chart when screen hard copy terminates normally

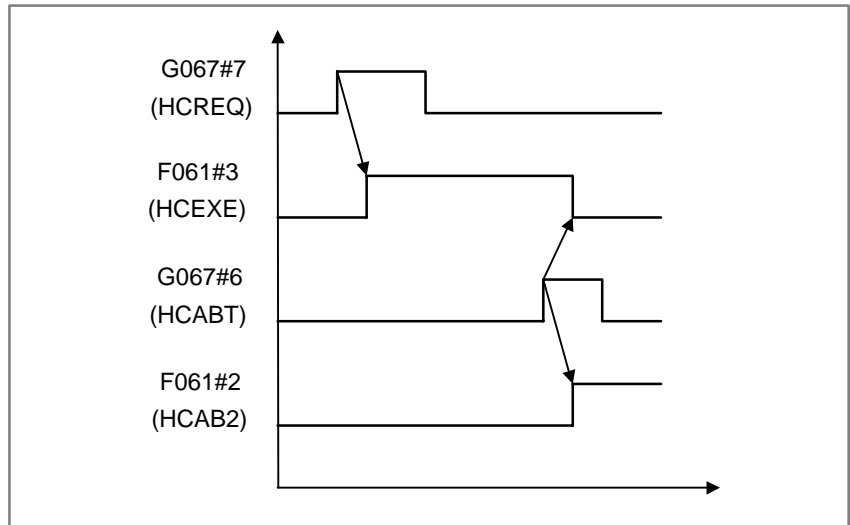

Fig. 13.9 (b) Time chart when screen hard copy is interrupted

CAUTION

- 1 Even when hard copy operation is performed for screens on the second path side or loader control board side, the input signals related to the screen hard copy function must always be on the first path side. Hard-copy-related signals on the second path or loader control board side are not referenced.
- 2 Hard-copy-related output signals are all output to the first path side. These signals are not output to the second path and loader control board sides.
- 3 Even when the hard copy stop request acceptance signal (HCAB2, F063#2) is 1, another hard copy operation can start. In this case, HCAB2 is set to 0 automatically.
- 4 Even when the hard copy in-progress signal (F061#3) is set from 1 to 0 (hard copy operation is terminated for a cause), the next hard copy operation does not start unless G067#7 (HDCPY) is set to 0 once.

Signal Address

	#7	#6	#5	#4	#3	#2	#1	#0
G67	HCREQ	HCABT						
	#7	#6	#5	#4	#3	#2	#1	#0
F61					HCEXE	HCAB2		

Parameter

	#7	#6	#5	#4	#3	#2	#1	#0
3301	HDCPY				HCNEG	HCALM		HDCL1

[Data type] Bit

- HDCL1** When the screen display is in VGA compatible mode on a color LCD:
 0 : Hard copy is performed with 256-color BMP. (The same colors as those on the screen display can always be obtained, but data is transferred to the memory card slowly.)
 1 : Hard copy is performed with 16-color BMP. (Data is transferred to the memory card at high speed, but the colors in the data may differ from those on the screen display.)
- HCALM** When an alarm is issued during hard copy operation:
 0 : No alarm message is displayed.
 1 : An alarm message is displayed.
- HCNEG** When a hard copy is taken with the monochrome VGA or character card:
 0 : Characters (graphics) are in black, and the background is in white in the hard copy.
 1 : Characters (graphics) are in white, and the background is in black in the hard copy.
- HDCPY** Screen hard copy operation is:
 0 : Disabled.
 1 : Enabled.

CAUTION

- 1 When two-path control (including two-path control by one CPU) is performed and when the loader control board is used, set parameters for all paths.
- 2 In addition to the above parameters, it is necessary to set 4 in parameter No. 20 (I/O channel selection). When two-path control is performed and when the loader control board is used, set this parameter also for all paths.
- 3 When the C executor is used, the screen hard copy function allows the use of the [SHIFT] or [CAN] key only if bit 4 (CKM) of parameter No. 8650 is set to 1 (transferring the bit matrix of the MDI keys to the NC). Note that, however, some applications do not allow this bit to be set to 1, so care should be taken. (Even when bit 4 (CKM) of parameter No. 8650 is 0, screen hard copy is enabled using an input signal.)

Diagnostic screen

The hard copy status is output. When the hard copy start signal (HDCPY, G67#7) is not set to 1, pressing the reset button resets all bits of diagnostic number 35 to 0.

	#7	#6	#5	#4	#3	#2	#1	#0
0035				HCER3	HCER2	HCER1	HCAB3	HCEND

HCEND Normal termination of hard copy operation

HCAB3 Acceptance of hard copy interruption request

HCER1 Hard copy parameter setting error (= P/S5212)

HCAB2 Failure to obtain the right to exclusively use the memory card (= P/S5213)

HCAB3 Failure to write data to the memory card (= P/S5214)

14 MEASUREMENT



14.1 TOOL LENGTH MEASUREMENT (M SERIES)

General

The value displayed as a relative position can be set in the offset memory as an offset value by a soft key.

Switch to the offset value display screen on the CRT. Relative positions are also displayed on this screen. Then select the reference tool and set it at the fixed point on the machine by manual operation. Reset the displayed relative position to zero. Set the tool for measurement at the same fixed point on the machine by manual operation. The relative position display at this point shows difference between the reference tool and the tool measured and the relative position display value is then set as offset amounts.

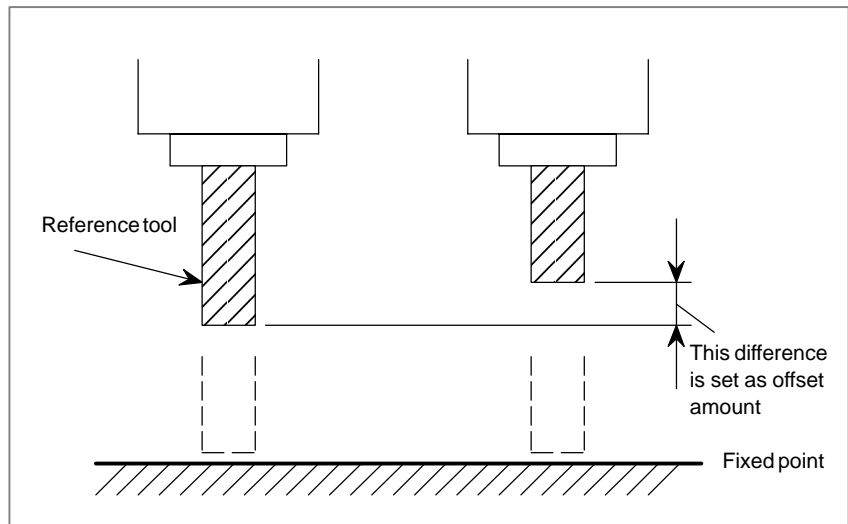

Reference Item

Series 16i/18i/160i/180i/ 160is/180is	OPERATOR'S MANUAL (For Machining Center) (B-63534EN)	III.11.4.2	Tool Length Measurement
Series 21i/210i/210is	OPERATOR'S MANUAL (For Machining Center) (B-63614EN)	III.11.4.2	Tool Length Measurement

14.2 AUTOMATIC TOOL LENGTH MEASUREMENT (M SERIES)/ AUTOMATIC TOOL OFFSET (T SERIES)

General

When a tool is moved to the measurement position by execution of a command given to the CNC, the CNC automatically measures the difference between the current coordinate value and the coordinate value of the command measurement position and uses it as the offset value for the tool. When the tool has been already offset, it is moved to the measurement position with that offset value. If the CNC judges that further offset is needed after calculating the difference between the coordinate values of the measurement position and the commanded coordinate values, the current offset value is further offset.

Signal

Measuring position
reached signals
XAE<X004#0>,
YAE<X004#1>,
ZAE<X004#2>(M series)
XAE<X004#0>,
ZAE<X004#1>(T series)

[Classification] Input signal

[Function] If the measuring position specified by a program command differs from the measuring position which a tool has reached in practice, that is, the position at the moment the measuring position reached signal has just been turned “1”, the difference in the coordinate value is added to the current tool compensation value to update the compensation value. The tool is first fed to the specified measuring position by rapid traverse in a block where one of the following commands has been specified:

G37 (M series)
G36, G37 (T series)

The tool decelerates and temporarily stops at the distance γ before the measuring position.

The tool then moves to the measuring position at the speed preset by a parameter No. 6241. If the measuring position reached signal corresponding to the G code is turned “1” after the tool has approached within distance ϵ of the measuring position and before the tool overshoots the measuring position by distance ϵ , the control unit updates the compensation value and terminates the move command for the block. If the measuring position reached signal is not turned “1” even after the tool has overshoot the measuring position by distance ϵ , the control unit enters an alarm state and terminates the move command for the block without updating the compensation value.

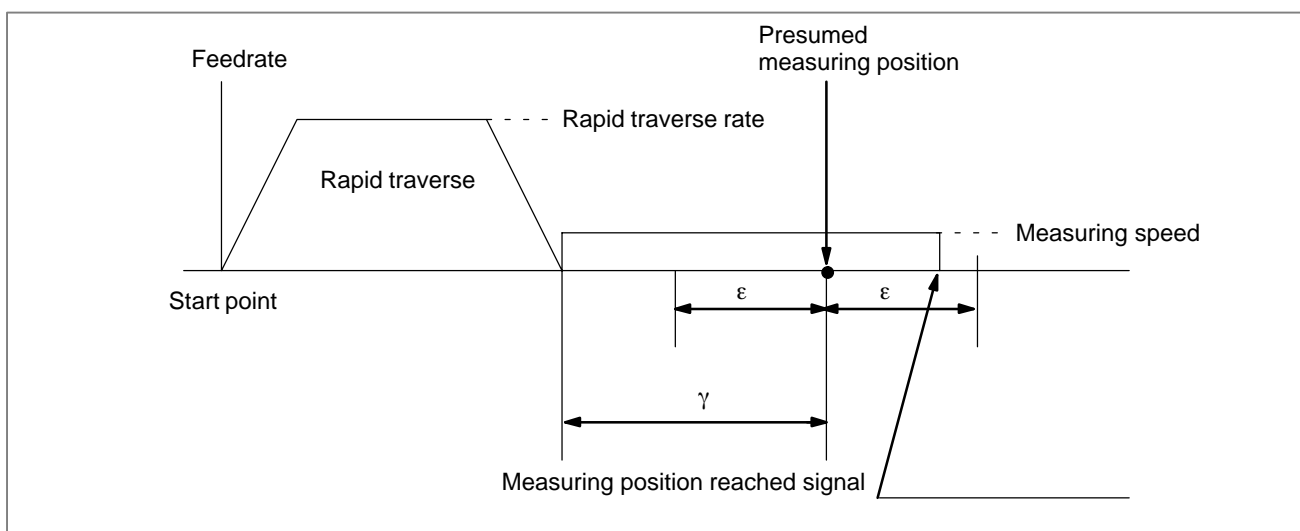

[Operation] When the signal is turned “1”, the control unit works as follows:

- Reads the position of the tool along the axis currently specified and updates the current compensation value based on the difference between the specified measuring position and the read measuring position in the following case: When the measuring position reached signal corresponding to the G code is turned on in a block where G36 (T series) or G37 is specified after the tool is within distance ϵ of the measuring position specified by a program and before the tool overshoots the measuring position by distance ϵ . The control unit then stops the tool, and terminates the move command for the block.
- Enters an alarm state and terminates the move command for the block without updating the compensation value in the following case: When the measuring position reached signal corresponding to the command is turned “1” in a block where G36 (T series), G37 is specified after the tool is within distance γ of the measuring position but before the tool is within distance ϵ of the measuring position.
- The control unit does not monitor the measuring position reached signal for its rising edge but monitors the state of the signal. If the signal remains “1” when the next corresponding automatic tool length measurement (automatic tool offset) is specified, the control unit enters an alarm state when the tool is within distance γ of the measuring position.

NOTE

- 1 The measuring position reached signal requires at least 10 msec.
- 2 The CNC directly inputs the measuring position reached signals from the machine tool; the PMC does not process them.
- 3 If automatic tool offset or automatic tool length measurement is not used, the PMC can use the signal terminals corresponding to the measuring position reached signal as the general-purpose input signals.

Signal address

	#7	#6	#5	#4	#3	#2	#1	#0
X004							ZAE	XAE
						ZAE	YAE	XAE

Parameter

6241	Feedrate during measurement of automatic tool offset
	Feedrate during measurement of tool length automatic measurement

[Data type] Word

[Unit of data]

[Valid data range]

Increment system	Unit of data	Valid data range	
		IS-A, IS-B	IS-C
Metric input	1 mm/min	6 to 15000	6 to 12000
Inch input	0.1 inch/min	6 to 6000	6 to 4800
Rotation axis	1 deg/min	6 to 15000	6 to 12000

This parameter sets the feedrate during measurement of automatic tool offset (T series) and tool length automatic compensation (M series).

6251	γ value on X axis during automatic tool offset
	γ value during tool length automatic measurement

6252	γ value on Z axis during automatic tool offset

[Data type] Two-word

[Unit of data]

Increment system	IS-A	IS-B	IS-C	Unit
Metric input	0.01	0.001	0.0001	mm
Inch input	0.001	0.0001	0.00001	inch

[Valid data range] 1 to 99999999

These parameters set the γ value during automatic tool offset (T series) or tool length automatic measurement (M series).

CAUTION

Set a radius value irrespective of whether the diameter programming or the radius programming is specified.

6254	ε value on X axis during automatic tool offset
	ε value during tool length automatic measurement
6255	ε value on Z axis during tool automatic offset

[Data type] Two-word

[Unit of data]	Increment system	IS-A	IS-B	IS-C	Unit
	Metric input	0.01	0.001	0.0001	mm
	Inch input	0.001	0.0001	0.00001	inch

[Valid data range] 1 to 99999999

These parameters set the ε value during automatic tool offset (T series) or tool length automatic measurement (M series).

CAUTION

Set a radius value irrespective of whether the diameter programming or the radius programming is specified.

Alarm and message

Number	Message	Description
080	G37 ARRIVAL SIGNAL NOT ASSERTED (M series)	In the automatic tool length measurement function (G37), the measurement position reached signal (XAE, YAE, or ZAE) is not turned on within an area specified in parameter 6254 (value ϵ). This is due to a setting or operator error.
	G37 ARRIVAL SIGNAL NOT ASSERTED (T series)	In the automatic tool offset function (G36, G37), the measurement position reached signal (XAE or ZAE) is not turned on within an area specified in parameter 6254, and 6255 (value ϵ). This is due to a setting or operator error.
081	OFFSET NUMBER NOT FOUND IN G37 (M series)	Tool length automatic measurement (G37) was specified without a H code. (Automatic tool length measurement function) Modify the program.
	OFFSET NUMBER NOT FOUND IN G37 (T series)	Automatic tool offset (G36, G37) was specified without a T code. (Automatic tool compensation function) Modify the program.
082	H-CODE NOT ALLOWED IN G37 (M series)	H code and automatic tool measurement (G37) were specified in the same block. (Automatic tool length measurement function) Modify the program.
	T-CODE NOT ALLOWED IN G37 (T series)	T code and automatic tool offset (G36, G37) were specified in the same block. (Automatic tool compensation function) Modify the program.
083	ILLEGAL AXIS COMMAND IN G37 (M series)	In automatic tool length measurement, an invalid axis was specified or the command is incremental. Modify the program.
	ILLEGAL AXIS COMMAND IN G37 (T series)	In automatic tool offset (G36, G37), an invalid axis was specified or the command is incremental. Modify the program.

Note**NOTE**

- 1 Measurement speed, γ , and ε are set as parameters. ε must be positive numbers and satisfy the condition of $\gamma > \varepsilon$.
- 2 The compensation value is updated by the following formula:

New compensation value = (Current compensation value) + [(Current position of the tool along the specified axis when the measuring position reached signal is "1") - (specified measuring position)]

The following compensation values are updated:

- (1) In a M series, the compensation value corresponding to the tool compensation number selected by an H code.
 - When offset memory A is used, the offset value is changed.
 - When offset memory B is used, the tool wear compensation value is changed.
 - When offset memory C is used, the tool wear compensation value for the H code is changed.
 - (2) In a T series, the compensation value corresponding to the tool compensation number selected by a T code and to the specified axis (X, Z) in G36, G37.
- 3 The maximum measuring error is calculated as shown below.

$$\text{ERRmax} = F_m \times \frac{1}{60} \times \frac{4}{1000}$$

ERRmax: Maximum measuring error (mm)

F_m : Measuring feedrate (mm/min)

If $F_m = 100$ mm/min, for example, ERRmax = 0.007 mm

- 4 After the measuring position reached signal has been detected, the tool moves for a maximum of 20 msec, then stops. Values for calculating the compensation amount, that is the coordinate of the tool where the tool reached the measuring position are not those obtained after stop, but those obtained at the position where the measuring position reached signal was detected.

The overtravel amount for 20 msec is calculated as follows.

$$Q_{\text{max}} = F_m \times \frac{1}{60} \times \frac{1}{1000} (20 + T_s)$$

Q_{max} : Maximum overtravel amount (mm)

F_m : Measuring feedrate (mm/min)

T_s : Servo time constant [msec] (1/loop gain)

Reference item

Series 16i/18i/160i/180i/ 160is/180is	OPERATOR'S MANUAL (For Machining Center) (B-63534EN)	II.14.2	AUTOMATIC TOOL LENGTH MEASUREMENT (G37)
	OPERATOR'S MANUAL (For Lathe) (B-63524EN)	II.14.6	AUTOMATIC TOOL OFFSET (G36, G37)
Series 21i/210i/210is	OPERATOR'S MANUAL (For Machining Center) (B-63614EN)	II.14.2	AUTOMATIC TOOL LENGTH MEASUREMENT (G37)
	OPERATOR'S MANUAL (For Lathe) (B-63604EN)	II.14.5	AUTOMATIC TOOL OFFSET (G36, G37)

14.3 SKIP FUNCTION

14.3.1 Skip Function

General

Linear interpolation can be commanded by specifying axial move following the G31 command, like G01. If an external skip signal is input during the execution of this command, execution of the command is interrupted and the next block is executed.

The skip function is used when the end of machining is not programmed but specified with a signal from the machine, for example, in grinding. It is used also for measuring the dimensions of a workpiece.

The coordinate values when the skip signal is turned on can be used in a custom macro because they are stored in the custom macro system variable #5061 to #5068, as follows:

```
#5061 First axis coordinate value
#5062 Second axis coordinate value
#5063 3rd axis coordinate value
:
:
#5068 8th axis coordinate value
```

Signal

Skip Signal
SKIP<X004#7>
SKIPP<G006#6>
(T series)

[Classification] Input signal

[Function] This signal terminates skip cutting. That is, the position where a skip signal turns to “1” in a block containing G31 is stored in a custom macro variable, and the move command of the block is terminated at the same time.

[Operation] When a skip signal turns to “1”, the control unit works as described below.

- When a block contains a skip cutting command G31, the control unit reads and stores the current position of the specified axis at that time. The control unit stops the axis, then cancels the remaining distance that the block was supposed to be moved.
- The skip signal is monitored not for a rising edge, but for its state. So, if a skip signal continues to be “1”, a skip condition is assumed to be satisfied immediately when the next skip cutting is specified.

NOTE

- 1 The skip signal width requires at least 10 msec.
- 2 The CNC directly reads the skip signal SKIP<X004#7> from the machine tool; the PMC is no longer requires to process the signal.
- 3 If the skip function G31 is not used, the PMC can use the signal terminal SKIP<X004#7> corresponding to the skip signal as a general purpose input signal.

Signal address

	#7	#6	#5	#4	#3	#2	#1	#0
X004	SKIP							
	#7	#6	#5	#4	#3	#2	#1	#0
G006		SKIPP						

Parameter

	#7	#6	#5	#4	#3	#2	#1	#0
6200	SKF						SK0	GSK
	SKF						SK0	

[Data type] Bit

GSK In skip cutting (G31), the signal SKIPP (bit 6 of G006) is:

0 : Not used as a skip signal.

1 : Used as a skip signal.

SK0 This parameter specifies whether the skip signal is made valid under the state of the skip signal SKIP <X004#7> and the multistage skip signals <X004> (for the T series only).

0 : When these signals are 1, they are assumed to be input (skip).

1 : When these signals are 0, they are assumed to be input (skip).

SKF Dry run, override, and automatic acceleration/deceleration for G31 skip command

0 : Disabled

1 : Enabled

Alarm and message

Number	Message	Description
035	CAN NOT COMMANDED G31 (T series)	Skip cutting (G31) was specified in tool nose radius compensation mode. Modify the program.
036	CAN NOT COMMANDED G31 (M series)	Skip cutting (G31) was specified in cutter compensation mode. Modify the program.

Warning**WARNING**

Disable feedrate override, dry run, and automatic acceleration/deceleration (enabled with parameter No. 6200#7 SKF=1) when the feedrate per minute is specified, allowing for reducing an error in the position of the tool when a skip signal is input. These functions are enabled when the feedrate per rotation is specified.

Note**NOTE**

- 1 The G31 block is always set to G01 mode. The feedrate is specified by an F code.
- 2 When the measuring motion is made by utilizing the skip signal, program a constant feedrate; otherwise, if the feedrate changes, the measuring error will be noticeable. With a constant feedrate, the maximum measuring error can be calculated as follows:

$$\text{ERRmax} = F_m \times \frac{1}{60} \times \frac{4}{1000}$$

ERRmax: Maximum measuring error (mm or inch)

Fm : Measuring feedrate (mm/min or inch/min)

- 3 Overtravel amount Qmax after skip signal has been turned to "1" is calculated by the following:

$$Q_{\text{max}} = F_m \times \frac{1}{60} \times \frac{1}{1000} (20^{(*)} + T_c + T_s)$$

Qmax : Overtravel amount (mm or inch)

Fm : Feedrate (mm/min or inch/min)

Tc : Cutting time constant (ms)

Ts : Servo time constant (ms) (1 loop gain)

(*) : The value becomes 28 when the skip signal SKIPP <G006#6> is used. (Also it changes according to the processing time of ladder program).

Reference item

Series 16i/18i/160i/180i/ 160is/180is	OPERATOR'S MANUAL (For Machining Center) (B-63534EN)	II.4.16	SKIP FUNCTION(G31)
	OPERATOR'S MANUAL (For Lathe) (B-63524EN)	II.4.14	SKIP FUNCTION(G31)
Series 21i/210i/210is	OPERATOR'S MANUAL (For Machining Center) (B-63614EN)	II.4.8	SKIP FUNCTION(G31)
	OPERATOR'S MANUAL (For Lathe) (B-63604EN)	II.4.10	SKIP FUNCTION(G31)
Series 20i	OPERATOR'S MANUAL (For Manual Milling Machine) (B-64204EN)	II.4.6	SKIP FUNCTION (G31)
	OPERATOR'S MANUAL (For Manual Lathes) (B-64194EN)	II.4.8	SKIP FUNCTION (G31)

14.3.2 High-speed Skip Signal

General

The skip function operates based on a high-speed skip signal (HDI0 ~ HDI7 : connected directly to the CNC; not via the PMC) instead of an ordinary skip signal (X004#7). In this case, up to eight signals can be input. (Either can be enabled/disabled, using parameters (bit 4 of parameter No. 6201 and bit 4 of parameter No. 6200).) The Series 20i/21i/210i, however, uses just a single high-speed skip signal (HDI0). Delay and error of skip signal input is 0 to 2 msec at the CNC side (not considering those at the PMC side).

This high-speed skip signal input function keeps this value to 0.1 msec or less, thus allowing high precision measurement.

Acceleration / Deceleration and Servo Delay Compensation (Type A/B)

The skip function causes the NC to memorize the “current position” of the tool when a skip signal is input. However, the “current position” includes a delay in the servo system. In other words, the “current position” deviates by the distance corresponding to the servo delay from the position where the tool actually was when the skip signal was input. This deviation can be calculated from the positional error in the servo system and the number of remaining pulses due to feedrate acceleration/ deceleration in the NC. Taking this deviation into account eliminates the necessity to include the servo delay in a measurement error.

The deviation of the “current position” can be compensated for by either of the following two types, using parameter SEA (bit 0 of parameter No. 6201) or parameter SEB (bit 1 of parameter No. 6201).

- (1) Type A: The deviation is calculated from the cutting time constant and the servo time constant (loop gain).
- (2) Type B: The deviation is assumed to be a sum of the number of remaining pulses due to acceleration/deceleration caused when the skip signal is turned on, and the positional error.

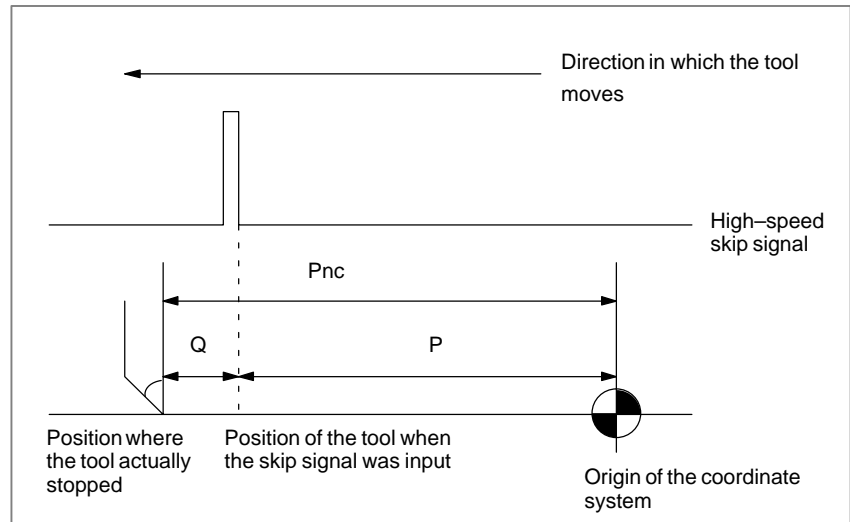

P_{nc} : Position where the tool actually stopped after the skip signal was input [mm/inch]

P : Distance to be measured [mm/inch]

Q : Servo delay [mm/inch]

Under the conditions shown above, the NC calculates the following equation using parameter SEA (bit 0 of parameter No. 6201) or SEB (bit 1 of parameter No. 6201):

$$P = P_{nc} - Q$$

For type A (SEA bit 0 of parameter No. 6201 is "1"), the deviation is calculated by:

$$Q = F_m \times 1/60 \times (\alpha \times T_c/1000 + T_s/1000)$$

where

F_m : Feedrate [mm/min or inch/min]

T_c : Cutting time constant [msec]

Parameter No. 1622: Exponential acceleration/deceleration

Parameter No. 1628: Linear acceleration/deceleration after interpolation

If parameter SKF (bit 7 of parameter No. 6200) = 0, $T_c = 0$.

T_s : Servo time constant [msec]

Assuming that the loop gain (parameter No. 1825) is G (unit: 1/s):

$$T_s = 1000/G$$

α : = 1 Exponential acceleration/deceleration

= 1/2 Linear acceleration/deceleration after interpolation

NOTE

For type A (parameter SEA (No. 6201 #0)=1), the skip signal must be turned on when the tool moves at constant feedrate.

Signal
**High Speed Skip Status
Signal
HDO0 to HDO7<F122>**

[Classification] Output signal

[Function] This signal informs the PMC of the input status of the high-speed skip signal. The signal-to-bit correspondence is as follows:

High-speed skip signal	——	Bit name
HDI0	——	HDO0
HDI1	——	HDO1
HDI2	——	HDO2
HDI3	——	HDO3
HDI4	——	HDO4
HDI5	——	HDO5
HDI6	——	HDO6
HDI7	——	HDO7

[Output condition] Each bit is set to 1 when:

- The corresponding high-speed skip signal is logical 1.

Each bit is set to 0 when:

- The corresponding high-speed skip signal is logical 0.

Signal address

	#7	#6	#5	#4	#3	#2	#1	#0
F122	HDO7	HDO6	HDO5	HDO4	HDO3	HDO2	HDO1	HDO0

Parameter

	#7	#6	#5	#4	#3	#2	#1	#0
6200		SRE		HSS				

[Data type] Bit type

HSS 0 : The skip function does not use high-speed skip signals.
1 : The skip function uses high-speed skip signals.

SRE When a high-speed skip signal is used:
0 : The signal is considered to be input 1.
1 : The signal is considered to be input 1.

	#7	#6	#5	#4	#3	#2	#1	#0
6201				IGX			SEB	SEA

[Data type] Bit type

SEA When a high speed skip signal goes on while the skip function is used, acceleration/deceleration and servo delay are:

0 : Ignored.

1 : Considered and compensated (type A).

SEB When a high speed skip signal goes on while the skip function is used, acceleration/deceleration and servo delay are:

0 : Ignored.

1 : Considered and compensated (type B).

IGX When the high-speed skip function is used, SKIP (bit 7 of X004), SKIPP (bit 6 of G006), and +MIT1 to -MIT2 (bits 2 to 5 of X004) are:

0 : Enabled as skip signals.

1 : Disabled as skip signals.

NOTE

SKIPP (bit 6 of G006) and +MIT1 to -MIT2 (bits 2 to 5 of X004) are enabled only when bit 0 (GSK) of parameter No. 6200 is set to 1 and bit 3 (MIT) of parameter No. 6200 is set to 1. Note also that these signals are enabled only for the T series.

	#7	#6	#5	#4	#3	#2	#1	#0
6202	1S8	1S7	1S6	1S5	1S4	1S3	1S2	1S1

1S1~1S8

Specify which high-speed skip signal is enabled when the G31 skip command is issued. The bits correspond to the following signals:

0 : The skip signal corresponding to the bit is disabled.

1 : The skip signal corresponding to the bit is enabled.

1S1 — HDI0

1S2 — HDI1

1S3 — HDI2

1S4 — HDI3

1S5 — HDI4

1S6 — HDI5

1S7 — HDI6

1S8 — HDI7

NOTE

HDI0 to HDI7 are high-speed skip signals.

Reference item

CONNECTION MANUAL (Hardware) (B-63523EN)	5.4	CONNECTING THE HIGH-SPEED SKIP (HDI)
---	-----	---

14.3.3 Multi-step Skip

General

In a block specifying P1 to P4 after G31, the multi-step skip function stores coordinates in a custom macro variable and cancels the remaining distance that the block was supposed to be moved when a skip signal (8 points) or high-speed skip signal (8 points, however in the case of Series 21i/210i 1 point) is turned on.

Also in a block specifying Q1 to Q4 after G04, this function skips a dwell when the skip signal or high speed skip signal has turned on.

A skip signal from equipment such as a fixed-dimension size measuring instrument can be used to skip programs being executed.

In plunge grinding, for example, a series of operations from rough machining to spark-out can be performed automatically by applying a skip signal each time rough machining, semi-fine machining, fine-machining, or spark-out operation is completed.

Signal

Skip signal SKIP, SKIP2 to SKIP8 <X004>

[Classification] Input signal

[Function] These signals terminate skip cutting. That is, the position where a skip signal turns to “1” in a command program block containing G31P1 (or G31), G31P2, or G31P3, G31P4 is stored in a custom macro variable, and the move command of the block is terminated at the same time. Furthermore, in a block containing G04, G04Q1, G04Q2, G04Q3 or G04Q4, the dwell command of the block is terminated.

In either case, until all other commands (such as miscellaneous functions) of the block are completed, machining never proceeds to the next block.

Which of the eight skip signals is applicable to blocks containing the G codes can be determined by parameter (no. 6202 to 6206). The eight skip signals can correspond to the G codes on a one-to-one basis. One skip signal can also be made applicable to multiple G codes. Conversely, multiple skip signals can be made applicable to one G code.

[Operation] When a skip signal turns to “1”, the control unit functions as described below.

- When a block contains a G code from (G31, G31P1 to P4) for skip cutting, and the skip signal is made applicable by parameter setting to the command, the control unit reads and stores the current position of the specified axis at that time. The control unit stops the axis, then cancels the remaining distance that the axis was supposed to be moved in that block.
- When a block contains a G04, or G04Q1 to Q4 code for dwell, and the skip signal is made applicable by parameter setting to the command, the control unit stops dwell operation, and cancels any remaining dwell time.

- The skip signal is not monitored for a rising edge, but for its state. So, if a skip signal continues to be “1”, a skip condition is assumed to be satisfied immediately when the next skip cutting or dwell operation is specified.

Signal address

X004	#7	#6	#5	#4	#3	#2	#1	#0	(T series)
	SKIP	ESKIP SKIP6	-MIT2 SKIP5	+MIT2 SKIP4	-MIT1 SKIP3	+MIT1 SKIP2	ZAE SKIP8	XAE SKIP7	
X004	#7	#6	#5	#4	#3	#2	#1	#0	(M series)
	SKIP	ESKIP SKIP6	SKIP5	SKIP4	SKIP3	ZAE SKIP2	YAE SKIP8	XAE SKIP7	

WARNING

- 1 SKIP2 to SKIP6 are at the same addresses as skip signal ESKIP (axis control by PMC) and axial manual feed interlock signals +MIT1, -MIT1, +MIT2, and -MIT2 (direct input B for tool compensation measurements). Be careful when using both. (T series)
- 2 SKIP2 and SKIP6 to SKIP8 are at the same addresses as skip signal ESKIP (axis control by PMC) and measurement position arrival signal XAE, YAE, and ZAE (tool length automatic measurement). Be careful when using both. (M series)

CAUTION

If the automatic tool compensation option is used, SKIP5 to SKIP8 cannot be used. (T series)

Parameter

6200	#7	#6	#5	#4	#3	#2	#1	#0
			SLS	HSS				

[Data type] Bit type

- HSS** 0 : The skip function does not use high-speed skip signals.
 1 : The skip function uses high-speed skip signals.
- SLS** 0 : The multi-step skip function does not use high-speed skip signals while skip signals are input.
 1 : The multi-step skip function uses high-speed skip signals while skip signals are input.

NOTE

Skip signals (SKIP and SKIP2 to SKIP8) do not depend on the setting of this parameter. They are always enabled. And, it is possible to set disable with parameter IGX bit 4 of No. 6201.

	#7	#6	#5	#4	#3	#2	#1	#0
6202	1S8	1S7	1S6	1S5	1S4	1S3	1S2	1S1
6203	2S8	2S7	2S6	2S5	2S4	2S3	2S2	2S1
6204	3S8	3S7	3S6	3S5	3S4	3S3	3S2	3S1
6205	4S8	4S7	4S6	4S5	4S4	4S3	4S2	4S1
6206	DS8	DS7	DS6	DS5	DS4	DS3	DS2	DS1

[Data type] Bit type

1S1–1S8, 2S1–2S8, 3S1–3S8, 4S1–4S8, DS1–DS8

Specify which skip signal is enabled when the skip command (G31, or G31P1 to G31P4) and the dwell command (G04, G04Q1 to G04Q4) are issued with the multi-step skip function.

The following table shows the correspondence between the bits, input signals, and commands.

The settings of the bits have the following meanings:

0 : The skip signal corresponding to the bit is disabled.

1 : The skip signal corresponding to the bit is enabled.

Multi-step skip function					
Command Input signal	G31 G31P1 G04Q1	G31P2 G04Q2	G31P2 G04Q2	G31P4 G04Q4	G04
SKIP/HDI0	1S1	2S1	3S1	4S1	DS1
SKIP2/HDI1	1S2	2S2	3S2	4S2	DS2
SKIP3/HDI2	1S3	2S3	3S3	4S3	DS3
SKIP4/HDI3	1S4	2S4	3S4	4S4	DS4
SKIP5/HDI4	1S5	2S5	3S5	4S5	DS5
SKIP6/HDI5	1S6	2S6	3S6	4S6	DS6
SKIP7/HDI6	1S7	2S7	3S7	4S7	DS7
SKIP8/HDI7	1S8	2S8	3S8	4S8	DS8

NOTE

HDI0 to HDI7 are high-speed skip signals.

Note**NOTE**

The skip cutting commands G31 P1, G31 P2, G31 P3, and G31 P4 are all identical, except that they correspond to different skip signals. The tool moves along the specified axis performing linear interpolation until the SKIP signal is set to "1" or the end point of the specified movement is reached. The feedrate is specified in the program. G31 is the same as G31 P1.

Dwell commands G04, G04 Q1, G04 Q2, G04 Q3, and G04 Q4 are also identical, except that they correspond to different skip signals.

Reference item

Series 16i/18i/160i/180i/ 160is/180is	OPERATOR'S MANUAL (For Machining Center) (B-63534EN)	II.4.17	Multi-step Skip (G31)
	OPERATOR'S MANUAL (For Lathe) (B-63524EN)	II.4.15	Multi-step Skip (G31)
Series 21i/210i/210is	OPERATOR'S MANUAL (For Lathe) (B-63604EN)	II.4.11	Multi-step Skip (G31)

14.3.4 Torque Limit Skip

General

Specifying a move command after G31 P99 (or G31 P98) with a motor torque limit set (for example, specifying a torque limit on the PMC window) allows the same cutting feed as that specified with G01 to be performed.

While the tool is moved with a motor torque limit set during cutting feed, skip is performed when a signal indicating that the motor torque limit has been reached is input as a result of an operation such as pushing something against the motor.

• Basic operations

When the motor torque limit is reached or the SKIP signal <X0004#7> is input during the execution of G31 P99, the execution of the next block starts without executing the remaining portion of the move command.

When the motor torque limit is reached during the execution of G31 P98, the execution of the next block starts without executing the remaining portion of the move command. (The SKIP signal does not affect the execution of G31 P98.)

When no torque limit is specified before executing G31 P99 or P98, the move command is executed without performing the skip operation.

For G31 P99 and P98, the coordinate, indicating the position to which the tool is to be positioned after skip, is stored in the system variable of the custom macro.

Alarm No. 244 occurs if errors have accumulated to an amount (32767) that cannot be corrected in one distribution before the torque-limit-reached signal is input during the execution of G31 P99 or P98.

Signal

Torque limit reached signals TRQL1 to TRQL8 <F114>

[Classification] Output signal

[Function] Indicates that the torque limit has been reached.

[Output condition] Set to “1” when:

- The torque limit has been reached for the corresponding axis.

Set to “0” when:

- The torque limit has not been reached for the corresponding axis

Numbers 1 to 8 indicate the corresponding axis numbers.

Signal address

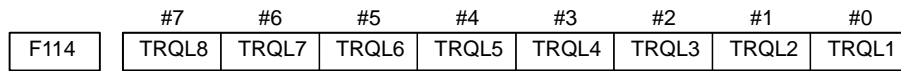

Parameter

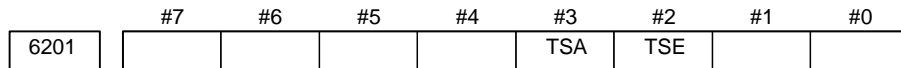

[Data type] Bit type

TSE When a skip operation is performed by the G31 P99 or P98 command used to specify torque limit skip:

- 0 : Corrects servo errors. (1)
- 1 : Does not correct servo errors. (2)

TSA Selects the axes to be monitored for whether the torque limit has been reached during the execution of the G31 P99 or 98 command used to specify torque limit skip:

- 0 : Monitors all axes.
- 1 : Monitors the axes specified by G31 P99 or P98.

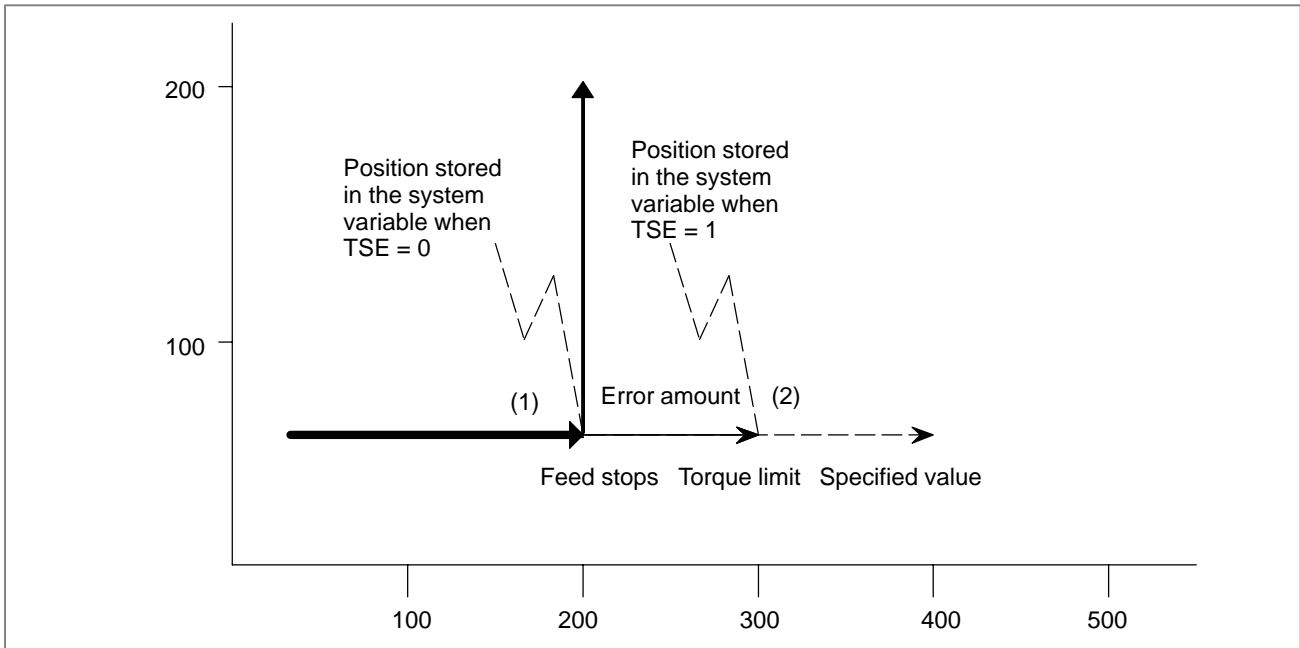

Alarm and message

Number	Message	Description
015	TOO MANY AXES COMMANDED	In the block including the command for the skip function (G31 P99/P98), to be executed under the control of the torque limit reach signal, no axis move command is specified, or two or more axes are specified. In a single block, specify one axis only.
244	P/S ALARM	When the skip function to be executed under the control of the torque limit reach signal is enabled, an error value (32767) that exceeds the maximum return value that can be handled with a single distribution is detected before input of the torque limit reach signal. Retry the processing after changing the axis feedrate, torque limit, or other conditions.

Caution

CAUTION

- 1 Specify a torque limit before G31 P99/P98. If G31 P99/P98 is executed with no torque limit specified, the move command is executed without a skip operation.
- 2 When G31 P99 is specified, the SKIP signal causes a skip operation. However, avoid using the high-speed skip operation.
- 3 Before specifying G31 P99/P98, cancel tool-tip radius compensation with G40.
- 4 Set the SKF bit (bit 7 of parameter No. 6200) to 0 to disable the dry run, override, and automatic acceleration/deceleration functions for the G31 skip command.

Reference item

Series 16i/18i/160i/180i/ 160is/180is	OPERATOR'S MANUAL (For Lathe) (B-63524EN)	II.4.16	TORQUE LIMIT SKIP
Series 21i/210i/210is	OPERATOR'S MANUAL (For Lathe) (B-63604EN)	II.4.12	TORQUE LIMIT SKIP
Series 20i	OPERATOR'S MANUAL (For Manual Lathes) (B-64194EN)	II.4.9	TORQUE LIMIT SKIP

14.3.5 Continuous High-speed Skip Function (M series)

General

The continuous high-speed skip function enables reading of absolute coordinates by using the high-speed skip signals (HDI0 to HDI7). Once a high-speed skip signal has been input in a G31P90 block, absolute coordinates are read into custom macro variables #5061 to #5068. The input of a skip signal does not stop axial movement, thus enabling reading of the coordinates of two or more points.

The rising and falling edges of the high-speed skip signal can be used as a trigger, depending on the parameter CSE (No. 6201#5) setting.

See “14.3.2 High-speed Skip Signal” for details of high-speed skip signal.

• Custom macro variables

Once a high-speed skip signal has been input in a G31P90 block, absolute coordinates are read into custom macro variables #5061 to #5068. These variables are immediately updated once the tool reaches the next skip position. The feedrate must, therefore, be specified such that the tool does not reach the next skip position before the application completes reading of the variables. The PMC program must be created to satisfy this condition.

#5061	Coordinate along the first axis
#5062	Coordinate along the second axis
#5063	Coordinate along the third axis
⋮	
#5068	Coordinate along the eighth axis

• High-speed skip signal

This function is enabled only when a high-speed skip signal is used.

The high-speed skip signal to be used is selected with bits 0 to 7 of parameter No. 6208 (9S1 to 9S8).

• End of block

The G31P90 block is terminated when the tool reaches the end point.

• Application (Example)

- (1) Reads custom macro variables, using the PMC window function.
- (2) Saves the values in the PMC data table (address D).
(The PMC window function cannot be used to save data.)
- (3) An execution or auxiliary macro is used for computation. They can directly read PMC address D, using the address function.

Limitations

• Controlled axes

Only one axis can be specified in the block for the continuous high-speed skip function (G31P90). If two or more axes are specified, P/S alarm No. 5068 is issued.

Signal

See Subsec. 14.3.2 High-speed Skip Signal

Parameter

	#7	#6	#5	#4	#3	#2	#1	#0
6200		SRE		HSS				

[Data type] Bit

HSS 0 : The skip function does not use high-speed skip signals.

1 : The skip function uses high-speed skip signals.

SRE When a high-speed skip signal is used:

0 : The signal is considered to be input at the rising edge (0 → 1).

1 : The signal is considered to be input at the falling edge (1 → 0).

	#7	#6	#5	#4	#3	#2	#1	#0
6201			CSE				SEB	SEA

[Data type] Bit

SEA When a high speed skip signal goes on while the skip function is used, acceleration/deceleration and servo delay are:

0 : Ignored.

1 : Considered and compensated (type A).

SEB When a high speed skip signal goes on while the skip function is used, acceleration/deceleration and servo delay are:

0 : Ignored.

1 : Considered and compensated (type B).

NOTE

Compensation can be performed in either of two ways: type A or type B. The skip signal of the skip function causes the NC to store the current position. The current position, stored in the NC, is subject to the servo delay and differs from the machine position by an amount corresponding to the servo delay. This difference can be determined from the position error of the servo system and the accumulated pulses caused by feed acceleration/deceleration executed by the NC. Provided this difference is considered, the servo delay need not be considered as a measurement error. The difference can be reduced by applying either of the following methods, as determined by the parameter settings.

1) Type A:

A value calculated from the cutting time constant and servo time constant (loop gain) is taken as the difference.

2) Type B:

The value calculated from the position error and the accumulated pulses caused by acceleration/deceleration, when the skip signal is enabled, is taken as the difference.

CSE For continuous high-speed skip command G31 P90, high-speed skip signals are :

0 : Effective at either a rising or falling edge (depending on the setting of bit 6 (SRE) of parameter No. 6200)

1 : Effective for both the rising and falling edges

	#7	#6	#5	#4	#3	#2	#1	#0
6208	9S8	9S7	9S6	9S5	9S4	9S3	9S2	9S1

[Data type] Bit

9S1 to 9S8 Specify valid high-speed skip signals for high-speed skip command G31P90. The bits correspond to signals as follows:

- 9S1 — HDI0
- 9S2 — HDI1
- 9S3 — HDI2
- 9S4 — HDI3
- 9S5 — HDI4
- 9S6 — HDI5
- 9S7 — HDI6
- 9S8 — HDI7

Set each bit as follows:

- 0 : The corresponding skip signal is invalid.
- 1 : The corresponding skip signal is valid.

6220	Period during which input is ignored for continuous high-speed skip signal
------	--

[Data type] Byte

[Unit of data] 8 msec

[Valid data range] 3 to 127 (× 8 msec)

If a value that falls outside this range is specified, 3 (× 8 msec) is assumed.

This parameter specifies the period that must elapse between a high-speed skip signal being input and input of the next high-speed skip signal being enabled, for the continuous high-speed skip function. This parameter is used to ignore chattering in skip signals.

(Example 1: Time interval specified when CSE (bit 5 of parameter No. 6201) = 0)

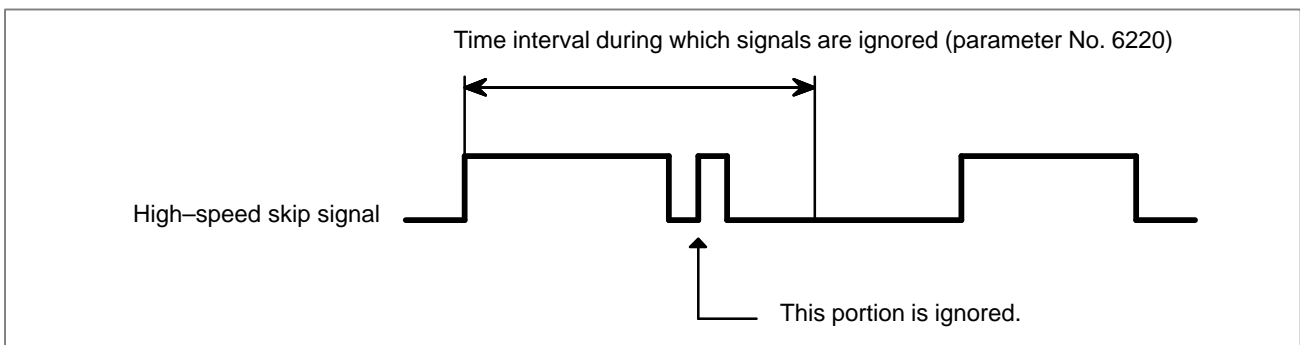

(Example 2: Time interval specified when CSE (bit 5 of parameter No. 6201) = 1)

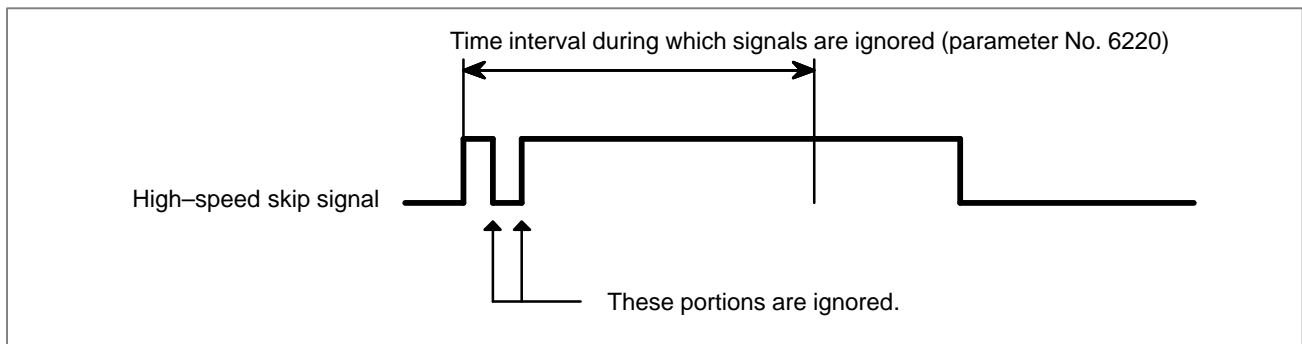

Alarm and message

Number	Message	Contents
5068	G31 P90 FORMAT ERROR	No axis is specified for movement. Two or more axes were specified for movement.

Reference item

Series 16i/18i/160i/180i/ 160is/180is	OPERATOR'S MANUAL (For Machining Center) (B-63534EN)	II.4.19	Continuous high-speed skip signal
---	--	---------	-----------------------------------

14.3.6 Skip Function for EGB Axis (M series)

General

This function provides the capability that skip function or high speed skip function can be commanded for work axis in the EGB(Electronic Gear Box) synchronization mode.

The features are as follows.

- The program block to enable the function is not interrupted until the total number of skip signal inputs reaches a value specified in the same block.
- The synchronization by EGB is not stopped by any of skip signal inputs.
- The machine coordinate position of the EGB axis (work axis) at each time of the signal inputs is stored in one of consecutive custom macro variables. The top number of the variables is specified in the block.
- The total number of the inputs is stored in another specified variable.

As for the EGB function, see the subsection "1.14.1 Simple Electric Gear Box".

Format

<p>G81 T_ L_ ; (EGB mode on) G31.8 G91 α 0 P_ Q_ R_ ; (EGB skip command)</p> <p>P: The top number of the consecutive custom macro variables in which the machine coordinate positions of the EGB axis (work-piece axis) at the skip signal inputs are stored.</p> <p>α: EGB axis (Workpiece axis)</p> <p>Q: The maximum allowable number of the skip signal inputs. (Range of command value: 1 – 200)</p> <p>R: The number of the custom macro variable in which the total number of the inputs is stored. This data is usually the same as the value specified by Q. Therefore this is not necessarily specified. Specify it when the total number should be confirmed.</p>

G31.8 is a one-shot G code.

During the execution of the G31.8 block, the machine coordinate positions of the EGB

axis (work axis) at the skip signal inputs are stored in the consecutive custom macro variables where the top number of the variables is specified by P and the maximum allowable number of the skip signal inputs is specified by Q.

The total number of the skip signal inputs (i.e. the same value specified by Q) is stored in the variable specified by R.

Example

G81 T200 L2 ; (EGB mode on)

X_ ;

Z_ ;

G31.8 G91 C0 P500 Q200 R1 ; (EGB skip command)

After 200 times of skip signal inputs, 200 machine coordinate positions of the C axis are stored respectively in the consecutive custom macro variables #500 – #699.

The total number of skip signal inputs (i.e. 200) is stored in the custom macro variable #1.

Signal

See Subsections 14.3.1 and 14.3.2.

Parameter

	#7	#6	#5	#4	#3	#2	#1	#0
6200		SRE		HSS				

[Data type] Bit

HSS 0 : The skip function does not use high-speed skip signals.
1 : The skip function uses high-speed skip signals.

SRE When a high-speed skip signal is used:

0 : The signal is considered to be input at the rising edge (0 to 1).
1 : The signal is considered to be input at the falling edge (1 to 0).

	#7	#6	#5	#4	#3	#2	#1	#0
6208	9S8	9S7	9S6	9S5	9S4	9S3	9S2	9S1

[Data type] Bit

9S1 to 9S8 Specify which high-speed skip signal is enabled when the G31.8 EGB skip command is issued.

9S1	—	HDI0
9S2	—	HDI1
9S3	—	HDI2
9S4	—	HDI3
9S5	—	HDI4
9S6	—	HDI5
9S7	—	HDI6
9S8	—	HDI7

The bits correspond to the following signals:

0 : The skip signal corresponding to the bit is disabled.

1 : The skip signal corresponding to the bit is enabled.

6220	Minimal interval time to accept continuous high-speed skip signal inputs
------	--

[Data type] Byte

[Unit of data] 8 ms

[Valid data range] 3 to 127

This parameter specifies the minimal interval time after a skip signal input for the next skip signal input to be accepted.

It is used to ignore chattering of skip signals.

NOTE

If the value out of the valid range is specified, it will be regarded as 3 (i.e. 24 ms).

Alarm and message

Number	Message	Contents
5068	G31.8 FORMAT ERROR	When skip function for EGB axis (G31.8) is specified, there are wrong command as follows: <ul style="list-style-type: none"> – Movement command is specified for EGB axis (work axis). – More than one axis has been specified – P has not been specified in G31.8 block. – Q has been specified out of range.

Note**NOTE**

- 1 In the G31.8 block, only the EGB axis (work axis) should be commanded. When another axis is commanded, the P/S alarm (No.5068) will occur.
- 2 If P is not specified in the G31.8 block, the P/S alarm (No.5068) will occur.
- 3 If R is not specified in the G31.8 block, the total number of skip signal inputs is not stored in the custom macro variable.
- 4 The numbers of custom macro variables specified by P and R must be the existing ones. If any nonexistent variable is specified, the P/S alarm (No.115) will occur.
If all the variables ranged by P and Q are not among the existing ones, the P/S alarm (No.115) will occur, too.
- 5 You can select the type of skip functions, normal skip function or high speed skip function, by the parameter HSS(No.6200#4).
When high speed skip is selected, you can select a valid signal among high speed skip signals by setting parameter 9S1 to 9S8 (No.6208#0 to #7).
- 6 The parameters No.6201#0 and #1 are not effective for the G31.8 function.
The machine coordinate positions stored in macro variables do not include any compensation amount based on position errors and servo time constant (loop gain).

14.4 ENTERING COMPENSATION VALUES

14.4.1 Input of Offset Value Measured A (T series)

General

This is a function of setting an offset value by key-inputting a workpiece diameter manually cut and measured from the MDI keyboard.

First the workpiece is cut in the longitudinal or cross direction manually. When the position record signal is turned "1" (prepare a button on the machine operator's panel) on completion of the cutting, the workpiece coordinate value of X axis and Z axis at that time is recorded in the CNC. Then, withdraw the tool, stop the spindle, and measure the diameter if the cutting was on the longitudinal direction or measure the distance from the standard face if the cutting was on the facing. (The reference face is made as $Z = 0$.) When the measured value is entered on the offset value display screen, NC inputs the difference between the input measured value and the coordinate value recorded in NC, as the offset value of the offset number.

If you release the tool without moving the tool in the axis along which an offset value is entered but moves the tool along the other axis, an offset value can be set without using the position record signal.

The workpiece coordinate system can be shifted using the technique of directly inputting the measured value for offset. This technique is used when the coordinate system planned in the program does not match with the coordinate system actually set.

The procedures are the same as those for direct input for offset, except a difference of using the standard tool on the work shift screen.

Signal

Position record signal PRC <G040#6>

[Classification] Input signal

[Function] This signal is prepared for the function of input of offset value measured A. It is used to store in the control unit the data on the positions of the tool for tentative cutting. After measuring a dimension of the workpiece, input the measured value by the specified manual operation. The difference is then stored as the specified tool compensation value.

[Operation] The control unit stores the current position along X and Z axes when the signal turns to "1".

NOTE

To use this signal, set parameter PRC (No.5005#2) to 1.

Signal address

	#7	#6	#5	#4	#3	#2	#1	#0
G040		PRC						

Parameter

	#7	#6	#5	#4	#3	#2	#1	#0
5005						PRC		

[Data type] Bit type

PRC Direct input of tool offset value and workpiece coordinate-system shift value

0 : Not use a PRC signal

1 : Uses a PRC signal

Reference item

Series 16i/18i/160i/180i/ 160is/180is	OPERATOR'S MANUAL (For Lathe) (B-63524EN)	III.11.4.2	Direct Input of Tool Offset Measured
Series 21i/210i/210is	OPERATOR'S MANUAL (For Lathe) (B-63604EN)	III.11.4.2	Direct Input of Tool Offset Measured
Series 20i	OPERATOR'S MANUAL (For Manual Lathes) (B-64194EN)	III.13.4.2	Direct Input of Tool Offset Measured

14.4.2 Input of Tool Offset Value Measured B (T series)

General

When the touch sensor is provided, the tool offset value can be automatically settable in the tool offset memory, by moving the tool to make contact with the touch sensor during manual operation. The workpiece coordinate system shift amount can also be automatically set. In addition, using a tool setter function for a one-turret/two-spindle lathe enables the tool compensation amount measured value direct input B function to be used for two spindles also on the one-turret/two-spindle lathe.

• Touch sensor

Either of the following two cases may be selected depending on parameter setting.

- 1) If TS1 (bit 3 of parameter No. 5004) is 0

The touch sensor has two direction-specific contact faces for each axis, thus outputting four signals (+MIT1, +MIT2, -MIT1, and -MIT2) when contact is detected.

- 2) If TS1 (bit 3 of parameter No. 5004) is 1

A touch sensor based on one contact input outputs one signal (+MIT1) when the one-contact input detects contact. So, which of the two directions of each axis is involved is automatically determined, and feeding in the corresponding axis direction is disabled.

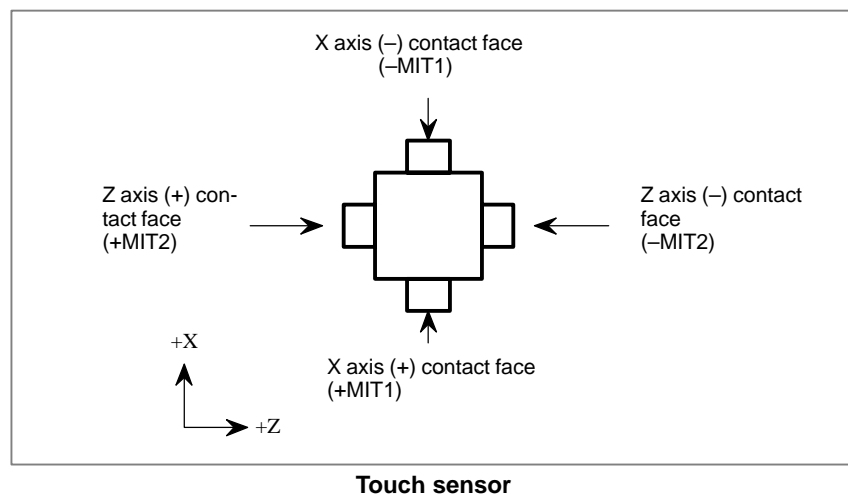

- **Setting tool offset value**

Determine a specific point on the machine tool as the measuring reference position. In advance, set the distance from this point to the measuring position (contact face of the touch sensor) as a reference value, using parameter No. 5015 to 5018. Select the tool whose offset value is to be measured, and bring it to touch the sensor, receiving a contact detection signal (tool compensation value write signal). The mechanical coordinate value is the distance from the tool nose position of the measuring tool at the mechanical reference (home) position to the measuring position; set the difference between this value and the reference value (parameter setting) into the tool offset value memory as the tool geometry offset value. The corresponding tool wear offset value becomes 0.

(Tool offset value to be set)

= (Mechanical coordinate value when tool compensation value write signal has become "1") – (Reference value (parameter value) corresponding to the tool compensation value write signal)

The tool offset value to be set differs according to the method of determining the measuring reference position.

If touch sensor contact detection is based on a one-contact input

If touch sensor contact detection is based on a one-contact input (the TS1 parameter (bit 3 of parameter No. 5004) is 1), when a contact detected signal (tool compensation amount write signal +MIT1) is received from the touch sensor, which of the two directions of each axis is involved is automatically determined according to several pulses stored as a result of the axis movement that was made before the signal reception. So the number of interpolation cycles related to the stored pulses must previously be set in parameter No. 5021.

Once which of the two directions of each axis is involved is automatically determined, the corresponding axis direction is subjected to axis interlock to stop feeding, and the obtained tool compensation amount is stored in tool compensation memory.

If the directions of stored pulses are not unified, or no pulse has been stored, for example, because the servo power has been shut off (servo off) or no axis movement occurred, a P/S alarm (No. 5195) is issued.

A P/S alarm is issued also if the tool moves along two axes (X-axis and Z-axis) simultaneously; move the tool along one axis at a time.

If a P/S alarm is issued, no tool compensation amount will be set up, resulting in the four directions (two axes) being subjected to interlock.

NOTE

- 1 Pulse storage for automatic decision is carried out in the manual mode while the GOSQM <G039#7> (tool compensation amount write mode select) signal is 1. Stored pulses are lost if:
 - a. The manual mode is exited,
 - b. The GOSQM <G039#7> (tool compensation amount write mode select) signal becomes 0,
 - c. A contact detected signal is received from the touch sensor, resulting in a tool compensation amount being set or a P/S alarm (No. 5195) being issued,
 - d. The servo power becomes off (resulting in the stored pulses for the related axis being lost), or
 - e. Axis movement occurs (resulting in the stored pulses for the other axis being lost).
- 2 Axis interlock that has occurred for the axis direction identified by parameter-based automatic decision and two-axis, four-direction interlock that has occurred because of a P/S alarm being issued are canceled when the manual mode is exited or the GOSQM <G039#7> (tool compensation amount write mode select) signal becomes 0.
A reset does not cancel interlock.

If the tool setter function for a one-turret/ two-spindle lathe is used

Parameter No. 5053 is used to specify for which spindle (1 or 2) tool compensation numbers (tool compensation amount memory) are to be used.

Example) If there are 16 tool compensation sets

Tool compensation number	Parameter No. 5053	
	8	10
Spindle 1	1 to 8	1 to 10
Spindle 2	9 to 16	11 to 16

NOTE

If parameter No. 5053 for grouping tool compensation numbers is 0 or greater than the maximum allowable number of tool compensation sets, grouping is carried out as listed below.

Number of tool compensation sets	16	32	64	99
Spindle 1	1 to 8	1 to 16	1 to 32	1 to 49
Spindle 2	9 to 16	17 to 32	33 to 64	50 to 98

Select, manually or automatically, the tool compensation number to be set up, using the QNI parameter (bit 5 of No. 5005).

- QNI = 0 (manual selection)

Set the cursor to the desired tool compensation number by operating the MDI (such as page and cursor keys).

- QNI = 1 (automatic operation)

In the offset write mode, the cursor is set to the desired tool compensation number, using the tool compensation number input signal.

For spindle 1, the cursor is set to a tool compensation number selected by the input signal.

For spindle 2, the cursor is set to the sum of the value specified in parameter No. 5053 and the tool compensation number selected by the input signal. In this case, the MDI cannot be used to change the cursor position on the offset screen.

NOTE

If the tool compensation number specified by the tool compensation number input signal is out of range, the last tool compensation amount memory number for each spindle is set up.

Example 1

The difference between the reference tool nose tip position and the measuring tool nose tip position can be set as the tool offset value. Define the reference tool nose tip position at the mechanical reference position (machine zero position) as the measuring reference position, then set the distances X_p , Z_p , X_m , Z_m , from the measuring reference position to the contact faces of the sensor in parameters.

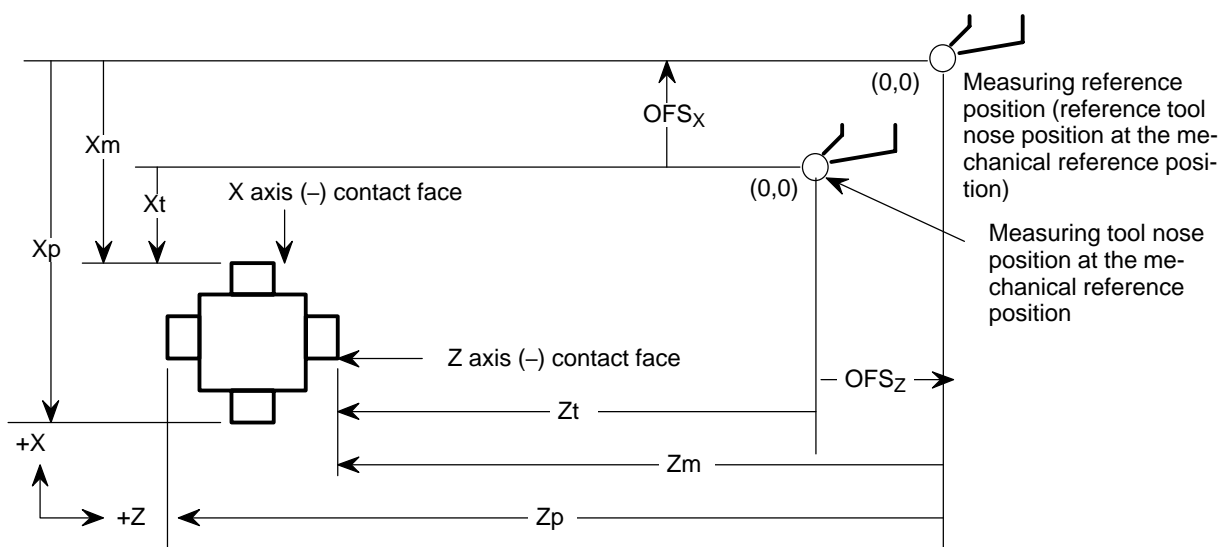

X_p : Distance from the measuring reference position to X-axis (+) contact face (parameter no. 5015)

X_m : Distance from the measuring reference position to X-axis (-) contact face (parameter no. 5016)

Z_p : Distance from the measuring reference position to Z-axis (+) contact face (parameter no. 5017)

Z_m : Distance from the measuring reference position to Z-axis (-) contact face (parameter no. 5018)

X_t : X-axis direction moving distance of the measuring tool up to the contact face of sensor (X-axis machine coordinate value)

Z_t : Z-axis direction moving distance of the measuring tool up to the contact face of sensor (Z-axis machine coordinate value)

(when X_t and Z_t touch the X-axis (-) contact face and Z-axis (-) contact face in the above figure)

OFS_x : Tool offset value to be set (X-axis): $OFS_x = X_t - X_m$

OFS_z : Tool offset value to be set (Z-axis): $OFS_z = Z_t - Z_m$

When the reference tool nose tip position is set as the measuring reference position

Example 2

The measuring reference point may be an imaginary point (imaginary zero point), as shown in the figure below. The difference between the imaginary zero point and the measuring tool nose tip position at the mechanical reference position can be set as the tool offset value of the measuring tool, by setting the distances from the imaginary zero point to the respective contact faces in parameters.

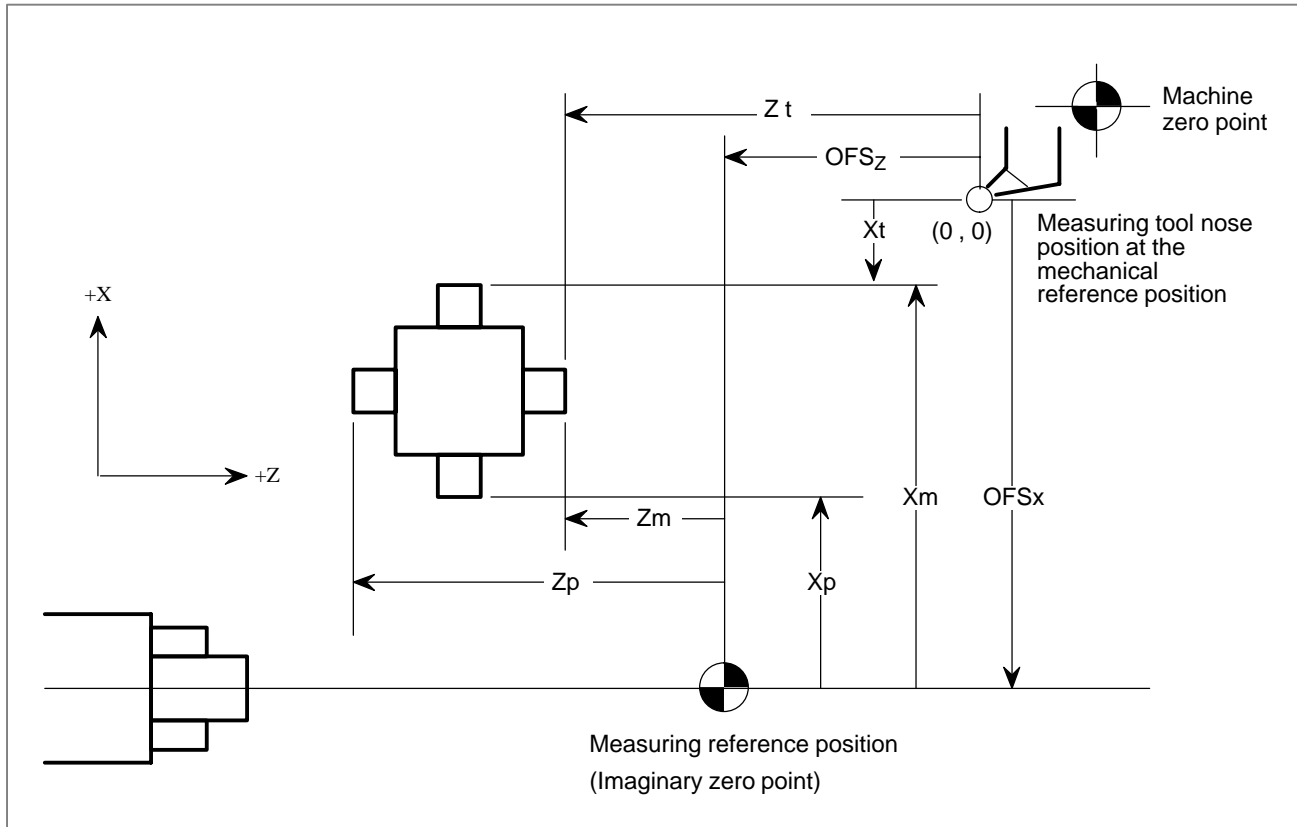

When the imaginary zero position is set as the measuring reference position

- **Setting the workpiece coordinate system shift amount**

The workpiece coordinate system shift amount for the Z-axis can be set as follows: Bring the tool to touch the workpiece end face. Subtract the tool geometry offset value of the tool (the value shifted in the coordinate system by the tool geometry offset) from the machine coordinate value (the distance from the measuring tool nose tip position at the mechanical reference position (machine zero point) to the workpiece end face). The result is set as the workpiece coordinate system shift value.

[Z axis workpiece coordinate system shift amount to be set (EXOF_Z)]

$$= [\text{Z axis tool geometry offset value of the corresponding tool (OFS}_Z)] - [\text{Z axis machine coordinate value}(Z_t)]$$

Using the above methods, the workpiece coordinate system is set with the workpiece end face (the contact point of the sensor) specified as the programmed zero point of the workpiece coordinate system of the Z-axis.

If the tool setter function for a one-turret/two-spindle lathe is used

For the tool set function for a one-turret/two-spindle lathe, the workpiece coordinate shift amount for the Z-axis is automatically set in any of workpiece coordinate systems G54 to G59 for workpiece coordinate system memory.

$$\begin{aligned} \text{[Z-axis workpiece coordinate system shift amount to be set up]} = \\ -([\text{corresponding Z-axis tool geometry compensation amount}] \\ - [\text{Z-axis machine coordinate value}]) \end{aligned}$$

Select the desired workpiece coordinate systems from G54 to G59 manually or automatically, using the 2AT parameter (bit 1 of No. 5051).

- 2AT = 0 (manual selection)
Set the cursor to the desired workpiece coordinate system G54 to G59 by operating the MDI (such as page and cursor keys).

NOTE

It is inhibited to select an external workpiece coordinate system offset (EXT). If the cursor is set to it, the warning message "Write inhibited" is displayed when the workpiece coordinate system shift write amount signal becomes 1.

- 2AT = 1 (automatic selection)
Previously set any of workpiece coordinate systems G54 to G59 in parameter No. 5054 for spindle 1 and parameter No. 5055 for spindle 2. When the workpiece coordinate system shift amount write mode is entered, the cursor is set to any of workpiece coordinate systems G54 to G59.

NOTE

If 0 or a value out of the valid data range is set in parameter No. 5053 or 5054, workpiece coordinate systems G54 and G57 are set up, respectively, for spindles 1 and 2.

Also select a tool compensation number to be used in measurement manually or automatically, using the QNI parameter (bit 5 of No. 5005).

- QNI = 0 (manual selection)
Specify the desired tool compensation number in parameter No. 5020.
- QNI = 1 (automatic selection)
The cursor is set to the desired tool compensation number, using the tool compensation number input signal.
For spindle 1, the cursor is set to a tool compensation number selected by the input signal.
For spindle 2, the cursor is set to the sum of the value specified in parameter No. 5053 and the tool compensation number selected by the input signal is used.

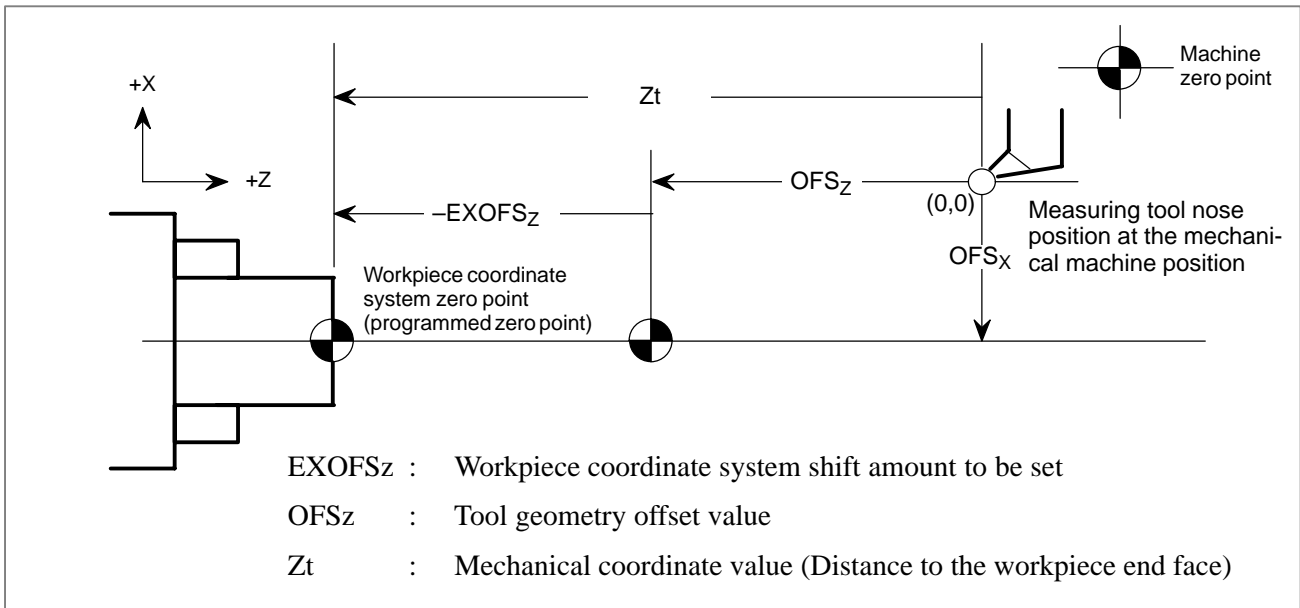

Setting of workpiece coordinate system shift amount

To deviate the programmed zero point of the workpiece coordinate system from the workpiece end face, such as by adding a cutting allowance, use the incremental input of the workpiece coordinate system shift amount in MDI operation. By setting the distance from the programmed zero point to the workpiece end face with a sign, the numeric value input is added to the preset amount.

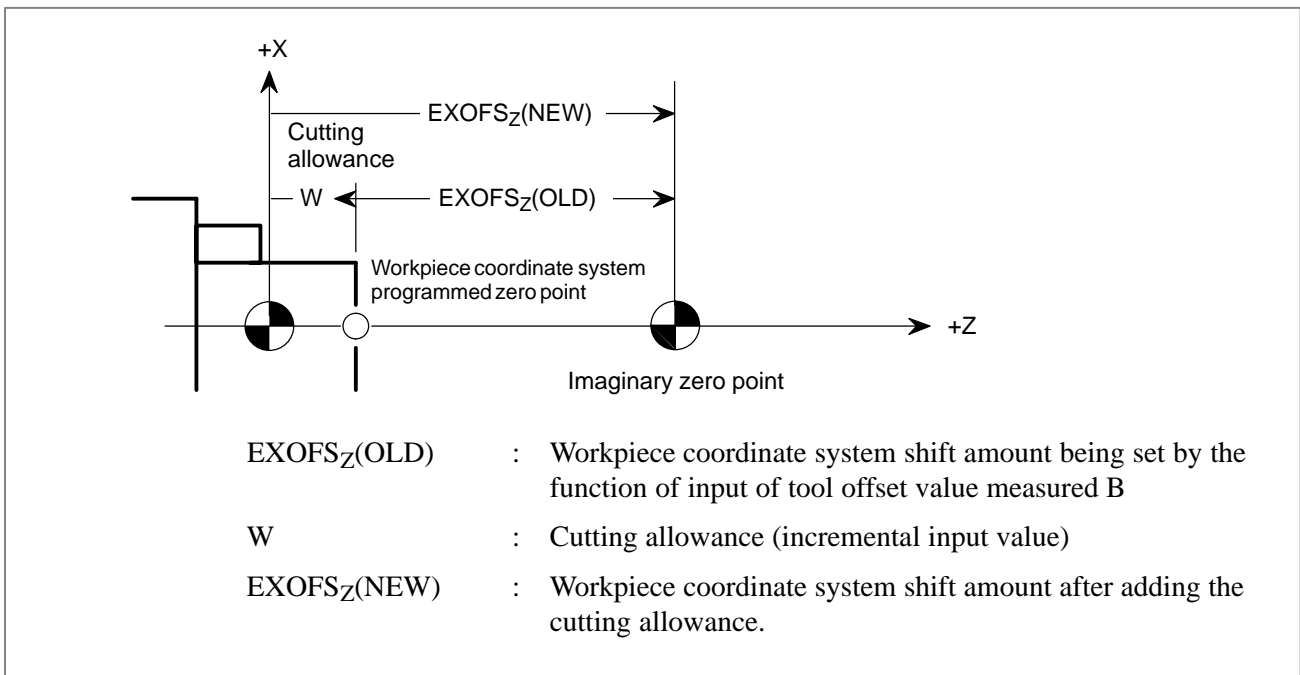

Setting of cutting allowance

Basic Procedure to Set Tool Offset Value

To use the tool setter function for a one-turret/two-spindle lathe, first specify the spindle to be measured, using the S2TLS (G040.5) (spindle measurement select) signal.

- (1) Execute manual reference position return.
By executing manual reference position return, a machine coordinate system is established.
The tool offset value is computed on the machine coordinate system.
- (2) Select manual handle mode or manual continuous feed mode and set the tool compensation value write mode select signal GOQSM to "1".
The CRT display is automatically changed to the tool offset screen (geometry), and the "OFST" indicator starts blinking in the status indication area at the bottom of the screen, which indicates that the tool compensation value writing mode is ready.
When the tool setter function for a one-turret/two-spindle lathe is in use, the S1MES or S2MES (spindle under measurement) signal, whichever is applicable, becomes 1.

NOTE

After this, it is impossible to switch the S2TLS (spindle measurement selection) signal until the GOQSM (offset write mode) signal becomes 0.

- (3) Select a tool to be measured.
- (4) When the cursor does not coincide with the tool offset number desired to be set, move the cursor to the desired offset number using the page key and cursor key.
The cursor can also be coincided with the tool offset number desired to be set automatically by the tool offset number input signals (when parameter QNI(No.5005#5)=1).
In this case, the position of the cursor cannot be changed on the tool compensation screen using page keys or cursor keys.
- (5) Near the tool to the sensor by manual operation.
- (6) Place the tool edge to a contacting surface of the sensor by manual handle feed.
Bring the tool edge in contact with the sensor. This causes the tool compensation value writing signals to input to be CNC.
The tool compensation value writing signal is set to "1", and the :
The following tool compensation amount write signals are set up according to the setting of the TS1 parameter (bit 3 of No. 5004).
When the parameter is 0: +MIT1, -MIT1, +MIT2, -MIT2
When the parameter is 1: +MIT1 only
 - i) The axis is interlocked in this direction and its feed is stopped.
 - ii) The tool offset value extracted by the tool offset memory (tool geometry offset value) which corresponds to the offset number shown by the cursor is set up.
- (7) For both X-axis and Z-axis, their offset values are set by operations (5) and (6).
- (8) Repeat operations (3) to (7) for all necessary tools.

Basic Procedure to Set Workpiece Coordinate Shift Value

- (9) Set the tool compensation value writing mode signal GOQSM to “0”. The writing mode is canceled and the blinking “OFST” indicator light goes off.

When the tool setter function for a one-turret/two-spindle lathe is in use, the S1MES or S2MES (spindle under measurement) signal for the spindle being measured becomes 0.

To use the tool setter function for a one-turret/two-spindle lathe, first specify the spindle to be measured, using the S2TLS <G040.5> (spindle measurement select) signal.

- (1) Set the tool geometry offset values of each tool in advance.
- (2) Execute manual reference position return.
By executing manual reference position return, the machine coordinate system is established.
The workpiece coordinate system shift amount is computed based on the machine coordinate system of the tool.
- (3) Set the workpiece coordinate system shift amount writing mode select signal WOQSM to “1”.
The LCD display automatically switches to the workpiece shifting screen, the “WFST” indicator starts blinking at the status indicator area in the bottom of the screen, which indicates that the workpiece coordinate system shift amount writing mode is ready.
When the tool setter function for a one-turret/two-spindle lathe is in use, the workpiece coordinate system screen is selected, and the S1MES or S2MES (spindle under measurement) signal, whichever is applicable, becomes 1.

NOTE

After this, it is impossible to switch the S2TLS (spindle measurement selection) signal until the WOQSM (offset write mode) signal becomes 0.

- (4) Select a tool to be measured.
- (5) Check tool offset numbers.
The tool offset number corresponding to the tool required for measurement, shall be set in the parameter (No.5020) in advance.
The tool offset number can also be set automatically by setting the tool offset number input signal (with parameter QNI(No.5005#5)=1).
- (6) Manually approach the tool to an end face of the workpiece.
- (7) Place the tool edge to the end face (sensor) of the workpiece using manual handle feed.
When the tool edge contacts the end face of the workpiece, input the workpiece coordinate system shift amount signal WOSET.
The workpiece coordinate system shift amount on the Z-axis is automatically set.
- (8) Release the tool.
- (9) Set the workpiece coordinate system shift amount write mode select signal WOQSM to “0”.

The writing mode is canceled and the blinking “WSFT” indicator light goes off.

When the tool setter function for a one-turret/two-spindle lathe is in use, the S1MES or S2MES (spindle under measurement) signal, whichever is applicable, becomes 0.

Signal

Tool offset write mode select signal GOQSM <G039#7>

[Classification] Input signal

[Function] Selects the mode for writing tool compensation.

[Operation] When this signal is turned “1” in a manual operation mode, the mode for writing tool compensation is selected. The control unit then automatically switches the screen displayed on the LCD to the tool geometry compensation screen and blinks the “OFST” status display at the bottom of the screen to notify that the mode has been changed to the mode for writing tool compensation.

Tool offset write signal (1-path control) +MIT1, +MIT2 <X004#2, #4> -MIT1, -MIT2 <X004#3, #5> (2-path control) +MIT1#1, +MIT2#1 <X004#2, #4> -MIT1#1, -MIT2#1 <X004#3, #5> +MIT1#2, +MIT2#2 <X013#2, #4> -MIT1#2, -MIT2#2 <X013#3, #5>

[Classification] Input signal

[Function] Each of these signals inhibits the tool from being fed along the corresponding axis during manual operation. When signal GOQSM for selecting the mode for writing tool compensation is set to “1”, the manual feed is inhibited and also the tool geometry compensation along the axis is automatically calculated and the result is set in tool compensation memory.

[Operation] When these signals are turned “1” during tool offset write mode, the control unit operates as follows:

- Inhibits tools from being fed along the corresponding axis during manual operation.
If the TS1 parameter (bit 3 of 5004) is 0
 - +MIT1 : Inhibits the tool from being manually fed in the positive direction along the X-axis.
 - MIT1 : Inhibits the tool from being manually fed in the negative direction along the X-axis.
 - +MIT2 : Inhibits the tool from being manually fed in the positive direction along the Z-axis.
 - MIT2 : Inhibits the tool from being manually fed in the negative direction along the Z-axis.
- If the TS1 parameter (bit 3 of 5004) is 1
 - +MIT1 : Automatic decision causes the related two directions of each axis to be subjected to interlock.
 - MIT1 : Not used
 - +MIT2 : Not used
 - MIT2 : Not used
- When signal GOQSM for selecting the mode for writing tool compensation is turned “1”, the manual feed interlock signal also automatically calculates the tool geometry compensation for the tool compensation number pointed to by the cursor and sets the result in tool compensation memory.

NOTE

- 1 This signal is used as the manual feed interlock signal in each axis direction.
- 2 This signal is valid only when the GSC parameter (bit 0 of No. 5009) is 0.

Tool offset write signal**+MIT1, +MIT2****<G132#0, #1>****-MIT1, -MIT2****<G134#0, #1>****[Classification]** Input signal

[Function] Each of these signals inhibits the tool from being fed along the corresponding axis during manual operation. When signal GOQSM for selecting the mode for writing tool compensation is set to “1”, the manual feed is inhibited and also the tool geometry compensation along the axis is automatically calculated and the result is set in tool compensation memory.

[Operation] When these signals are turned “1”, the control unit operates as follows:

- Inhibits tools from being fed along the corresponding axis during manual operation.
 - +MIT1 : Inhibits the tool from being manually fed in the positive direction along the X-axis.
 - MIT1 : Inhibits the tool from being manually fed in the negative direction along the X-axis.

+MIT2 : Inhibits the tool from being manually fed in the positive direction along the Z-axis.

-MIT2 : Inhibits the tool from being manually fed in the negative direction along the Z-axis.

If the TS1 parameter (bit 3 of 5004) is 1

+MIT1 : Automatic decision causes the related two directions of each axis to be subjected to interlock.

-MIT1 : Not used

+MIT2 : Not used

-MIT2 : Not used

- When signal GOQSM for selecting the mode for writing tool compensation is turned "1", the manual feed interlock signal also automatically calculates the tool geometry compensation for the tool compensation number pointed to by the cursor and sets the result in tool compensation memory.

NOTE

This signal is valid only when the bit 0 (GSC) of parameter No. 5009 is 1.

**Tool offset number
select signals
OFN0 to OFN5, OFN6
<G039#0 to #5, G040#0>**

[Classification] Input signal

[Function] Selects the tool offset number.

[Operation] When the mode for writing tool compensation is selected, the cursor is automatically positioned on the tool geometry compensation number selected by these signals.

A tool offset number is specified by a 7-bit binary number. Numbers 0 to 98 correspond to the compensation number 1 to 99.

NOTE

This signal is available only when parameter QNI (No. 5005#5) =1.

**Workpiece coordinate
system shift value write
mode select signal
WOQSM <G039#6>**

[Classification] Input signal

[Function] Selects the mode for writing the shift amount for the workpiece coordinate system.

[Operation] When this signal is turned to “1” in a manual operation mode, the mode for writing the shift amount for the workpiece coordinate system is selected. The control unit then automatically switches the screen displayed to the WORK SHIFT screen and blinks the “OFST” status display at the bottom of the screen to notify that the mode has been changed to the mode for writing the shift amount for the workpiece coordinate system. However, this is not performed when the mode for writing tool compensation values is selected.

**Spindle measurement
select signal
S2TLS <G040#5>**

[Classification] Input signal

[Function] For the tool setter function of the one-turret/two-spindle lathe, a spindle is selected for measurement. If the signal is 0, spindle 1 is selected. If it is 1, spindle 2 is selected.

If spindle 2 is to be selected for measurement, the tool compensation amount write mode signal and the workpiece coordinate system shift amount write mode signal as well as the spindle measurement select signal must be set to 1.

[Operation] If the signal is 0, spindle 1 is selected. If it is 1, spindle 2 is selected.

**Workpiece coordinate
system shift value write
signal
WOSET <G040#7>**

[Classification] Input signal

[Function] Automatically calculates and sets the shift amount for the workpiece coordinate system.

[Operation] When this signal turns to “1” in the mode for writing the shift amount for the workpiece coordinate system, it triggers the automatic calculation and setting of the shift amount for the workpiece coordinate system.

**Spindle 1 under measurement signal
S1MES <F062#3>
Spindle 2 under measurement signal
S2MES <F062#4>**

[Classification] Output signal

[Function] For the tool setter function of the one-turret/two-spindle lathe, it is indicated which spindle, 1 or 2, is under measurement.

[Output condition] These signals check which head is being measured in the tool compensation amount write mode or workpiece coordinate system shift amount write mode according to the S2TLS (spindle measurement select) signal.

If spindle 1 is selected, S1MES = 1 and S2MES = 0. If spindle 2 is selected, S1MES = 0 and S2MES = 1.

Signal address (1-path control)

	#7	#6	#5	#4	#3	#2	#1	#0
X004			-MIT2 SKIP5	+MIT2 SKIP4	-MIT1 SKIP3	+MIT1 SKIP2		

(2-path control)

	#7	#6	#5	#4	#3	#2	#1	#0
X004			-MIT2#1 SKIP5#1	+MIT2#1 SKIP4#1	-MIT1#1 SKIP3#1	+MIT1#1 SKIP2#1		
X013			-MIT2#2 SKIP5#2	+MIT2#2 SKIP4#2	-MIT1#2 SKIP3#2	+MIT1#2 SKIP2#2		

WARNING

Since the same addresses are used for both +MIT1, -MIT1, +MIT2, -MIT2 and skip signals SKIP2 to SKIP5 (multi-step skip), be careful when using these two signal types.

	#7	#6	#5	#4	#3	#2	#1	#0
G039	GOQSM	WOQSM	OFN5	OFN4	OFN3	OFN2	OFN1	OFN0
G040	WOSET		S2TLS					OFN6
F062				S2MES	S1MES			

Parameter

	#7	#6	#5	#4	#3	#2	#1	#0
3003					DIT			

[Data type] Bit**DIT** Interlock for each axis direction

0 : Enabled

1 : Disabled

	#7	#6	#5	#4	#3	#2	#1	#0
5004					TS1			

NOTE

When this parameter is set, the power must be turned off before operation is continued.

[Data type] Bit**TS1** When the tool offset measurement value direct input B function is used, touch sensor contact detection is based on:

0 : Four-contact input.

1 : One-contact input.

	#7	#6	#5	#4	#3	#2	#1	#0
5005			QNI					

[Data type] Bit**QNI** The function to input offset value measured B

0 : Does not automatically select the tool offset number

1 : Automatically selects a tool offset number

	#7	#6	#5	#4	#3	#2	#1	#0
5009								GSC

[Data type] Bit**GSC** Specifies from which the offset write input signal is to be input for the tool compensation amount measurement value direct input B function, as follows:

0 : To be input from the machine.

1 : To be input from the PMC.

NOTE

- 1 After setting this parameter, turn the power off then on again so that the setting will take effect.
- 2 If axis direction-specific interlock is enabled (bit 3 or parameter No. 3003 (DIT) is 0), its input is also switched from the machine to the PMC.

5015	Distance (X1P) between reference position and X axis + contact surface (touch sensor 1 side)
5016	Distance (X1M) between reference position and X axis – contact surface (touch sensor 1 side)
5017	Distance (Z1P) between reference position and Z axis + contact surface (touch sensor 1 side)
5018	Distance (Z1M) between reference position and Z axis – contact surface (touch sensor 1 side)
5056	Distance (X2P) between reference position and X axis + contact surface (touch sensor 2 side)
5057	Distance (X2M) between reference position and X axis – contact surface (touch sensor 2 side)
5058	Distance (Z2P) between reference position and Z axis + contact surface (touch sensor 2 side)
5059	Distance (Z2M) between reference position and Z axis – contact surface (touch sensor 2 side)

[Data type] Two-word

[Unit of data]	Increment system	IS-A	IS-B	IS-C	Unit
	Metric input	0.01	0.001	0.0001	mm
	Inch input	0.001	0.0001	0.00001	inch

[Valid data range] –99999999 to 99999999

These parameters are related to the function to input tool offset value measured B.

They set the distance (with sign) between the measurement reference position and sensor contact surface. For an axis under diameter programming, set it using a diameter value.

NOTE

Parameter Nos. 5056 to 5069 are valid if the 2NR parameter (bit 0 of parameter No. 5051) is 1.

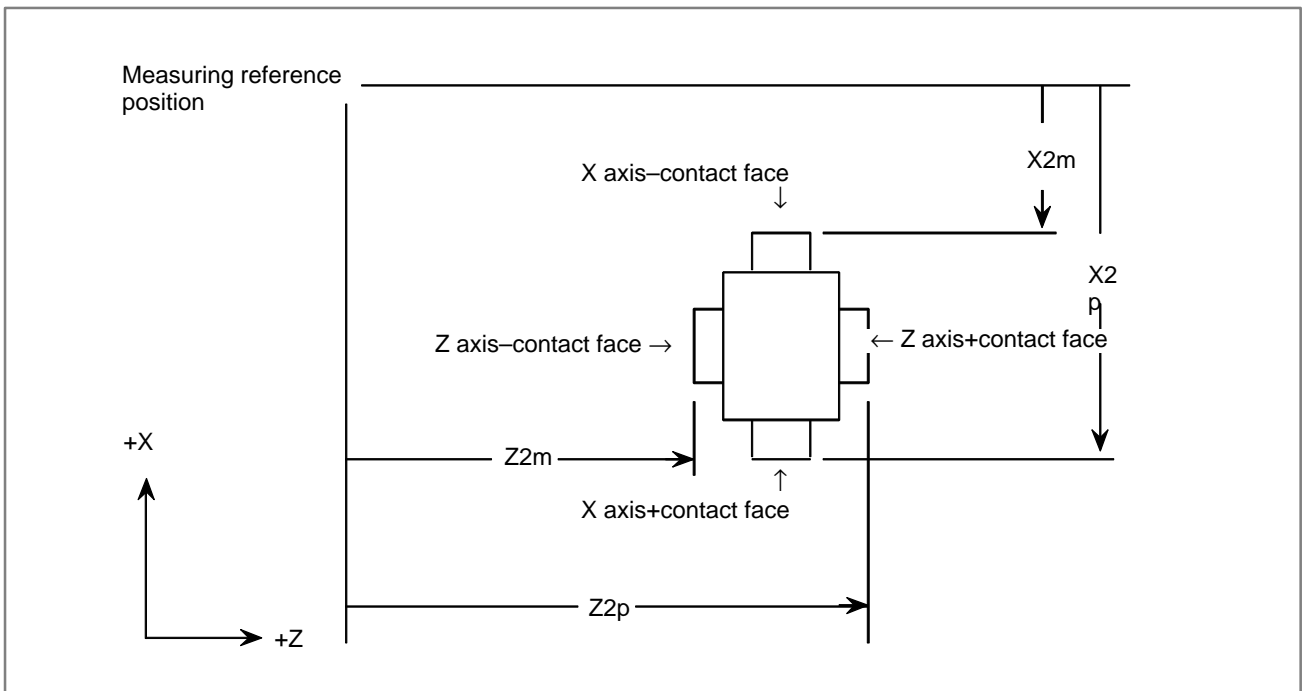
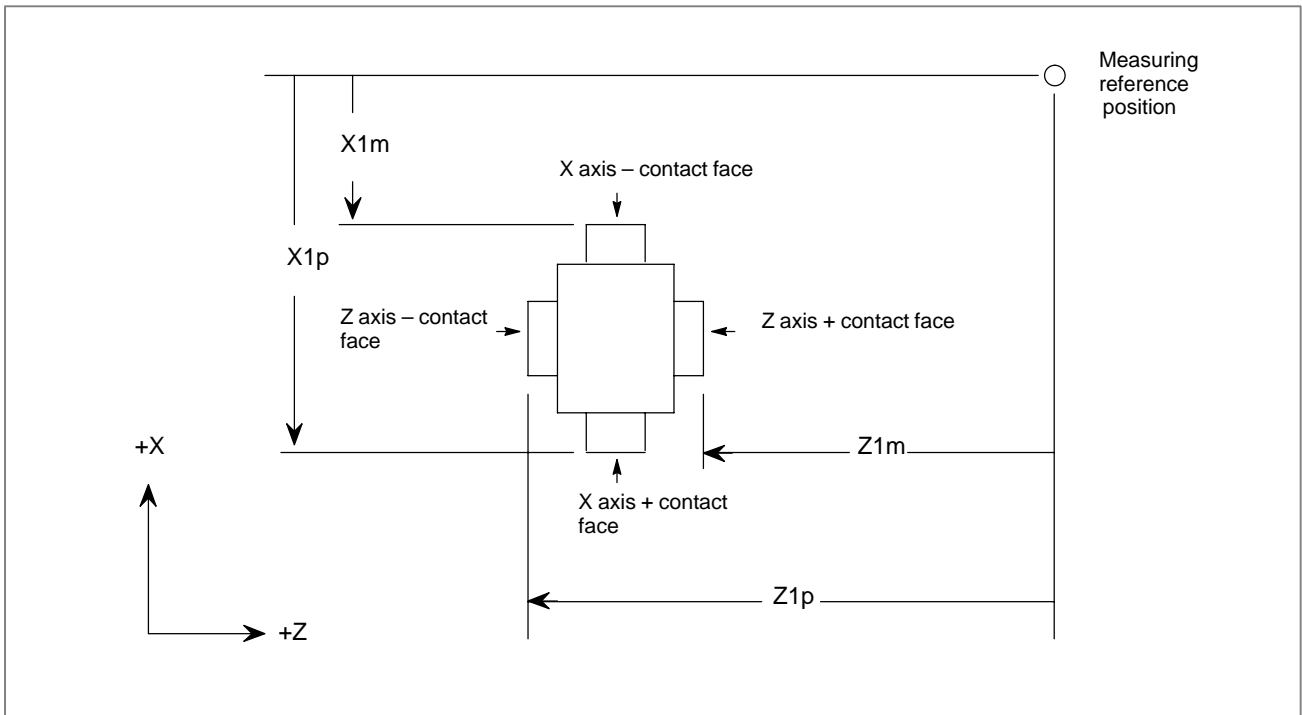

5020	Tool offset number used for the input of tool offset value measured B
------	---

[Data type] Byte

[Valid data range] 0 to the number of tools to be compensated.

Set tool offset number used for the input of tool offset value measured B function (i.e. when workpiece coordinate system shift value is set). (The tool offset number corresponding to the measured tool shall be set in advance.) This parameter is valid when the tool offset number is not selected automatically (QNI, #5 of parameter 5005, is zero).

5021	Number of pulse interpolation cycles memorized prior to contacting the touch sensor
------	---

[Data type] Byte

[Unit of data] Interpolation cycle

[Valid data range] 0 to 8

This parameter sets the number of pulse interpolation cycles to be memorized until the operator manually touches the tool with a one-contact input touch sensor when the tool offset measurement value direct input B function is used.

If 0 is set for this parameter, the specification of 8 (maximum allowable value) is assumed.

NOTE

This parameter is enabled when the TS1 parameter (bit 3 of parameter No.5004) is set to 1.

	#7	#6	#5	#4	#3	#2	#1	#0
5051							2AT	2NR

[Data type] Bit

2NR When the tool setter function for 1-turret, 2-spindle lathes is used:
 0 : One touch sensor is used for both main spindle 1 and main spindle 2.
 1 : Two touch sensors are used for both main spindle 1 and main spindle 2.

2AT When a workpiece reference point offset value is set in workpiece coordinate system memory with the tool setter function for 1-turret, 2-spindle lathes:
 0 : The value is set at the current cursor position.
 1 : A memory is automatically selected. (The workpiece coordinate system memory set in parameter No.5054 or No.5055 is selected.)

5053	Bias for tool offset numbers for measured tool offset value setting
------	---

[Data type] Byte

[Unit of data] Number

[Valid data range] 1 to maximum tool offset count

When the tool setter function for 1-turret, 2-spindle lathes is used, this parameter allocates tool offset numbers for measured tool offset measurement values to spindle 1 and spindle 2.

Example: When the tool offset count is 16 pairs

	Tool offset number	
	When setting = 8	When setting = 10
Spindle 1	1 to 8	1 to 10
Spindle 2	9 to 16	11 to 16

If 0 is set for this parameter, or if the maximum tool offset count is exceeded, the following is assumed:

	Tool offset number			
	16 pairs	32 pairs	64 pairs	99 pairs
Spindle 1	1 to 8	1 to 16	1 to 32	1 to 49
Spindle 2	9 to 16	17 to 32	33 to 64	50 to 98

5054	Workpiece coordinate system memory for spindle 1
------	--

5054	Workpiece coordinate system memory for spindle 2
------	--

[Data type] Byte

[Unit of data] Number

[Valid data range] 54 to 59

When the WNI parameter (bit 1 of parameter No.5051) is set to 1 specify, in each of these parameters, a workpiece coordinate system from G54 to G59 for workpiece reference point offset value setting.

NOTE

This is valid if the 2AT parameter (bit 1 of parameter No. 5051) is 1.

Alarm and message

Number	Message	Description
5195	DIRECTION CAN NOT BE JUDGED	<p>For a one-contact input touch sensor used with the tool compensation amount measurement value direct input B function, stored pulse directions are not unified.</p> <ul style="list-style-type: none"> The machine is at a stop in the offset write mode. The servo power is off. Pulse directions are diverse. <p>Alternatively, the tool is moving along two axes (X-axis and Z-axis) simultaneously.</p>

Reference item

Series 16i/18i/160i/180i/ 160is/180is	OPERATOR'S MANUAL (For Lathe) (B-63524EN)	III.11.4.3	Direct Input of Tool Offset Measured B
Series 21i/210i/210is	OPERATOR'S MANUAL (For Lathe) (B-63604EN)	III.11.4.3	Direct Input of Tool Offset Measured B

14.4.3 Input of Measured Workpiece Origin Offsets

General

By directly entering the measured deviation of the actual coordinate system from a programmed work coordinate system, the workpiece zero point offset at the cursor is automatically set so that a commanded value matches the actual measurement.

Reference item

Series 16i/18i/160i/180i/ 160is/180is	OPERATOR'S MANUAL (For Machining Center) (B-63534EN)	III.11.4.7	Input of Measured Workpiece Origin Offsets
	OPERATOR'S MANUAL (For Lathe) (B-63524EN)	III.11.4.11	Input of Measured Workpiece Origin Offsets
Series 21i/210i/210is	OPERATOR'S MANUAL (For Machining Center) (B-63614EN)	III.11.4.7	Input of Measured Workpiece Origin Offsets
	OPERATOR'S MANUAL (For Lathe) (B-63604EN)	III.11.4.11	Input of Measured Workpiece Origin Offsets

14.5 TOOL LENGTH/ WORKPIECE ORIGIN MEASUREMENT B (M SERIES)

General

Two functions have been provided to measure the tool length:
The automatic tool length measurement function (Section 14.2) automatically measures the tool length at a programmed command (G37);
The tool length measurement function (Section 14.1) measures the tool length after the target tool is manually moved until it touches the workpiece top surface or other reference position. In addition to the two conventional functions, tool length/workpiece origin measurement B has been provided to simplify the procedure of tool length measurement. This function facilitates the machining setup, resulting in a reduced machining setup time. The function also makes it easy to measure the workpiece origin offset.

With this function, the operator can program a T/M code or reference position return by specifying a manual numeric command on the tool length offset measurement screen.

Signal

Tool offset measurement mode selection signal GOQSM <G039#7>

[Classification] Input signal

[Function] Selects tool offset value measurement mode.

[Operation] When the signal goes to “1” in a manual operation mode, tool offset measurement mode is selected. The screen is automatically replaced with the tool geometry compensation screen. In the status display field at the bottom of the screen, “OFST” blinks to indicate that tool offset measurement mode has been selected.

Tool offset number selection signals OFN0 to OFN5, OFN6 to OFN9 <G039#0 to #5, G040#0 to #3>

[Classification] Input signal

[Function] Selects a tool offset number.

[Operation] In tool offset measurement mode, the cursor automatically moves to the tool offset number selected by the tool offset number input signal.

The ten code signals (binary code) select a tool offset number. Code signals 0 to 998 correspond to tool offset numbers 1 to 999.

NOTE

This signal is valid only when the QNI bit (bit of 5 parameter No. 5005) is set to 1.

Workpiece origin offset measurement mode selection signal WOQSM <G039#6>

[Classification] Input signal

[Function] Selects workpiece coordinate system shift measurement mode.

[Operation] When the signal goes “1” in manual operation mode, workpiece origin offset measurement mode is selected. The screen is automatically replaced with the workpiece coordinate system setting screen. In the status display field at the bottom of the screen, “WOFS” blinks to indicate that workpiece origin offset measurement mode has been selected.

Skip signal SKIP <X004#7>

[Classification] Input signal

[Function] Stores the momentary position, when the signal goes to “1” in the workpiece origin offset measurement, as a measured point. At the same time, the axial movement is stopped.

[Operation] When the skip signal is brought to “1” while the measurement probe is touching the reference plane or the external edge of the reference hole in the workpiece origin offset value measurement, the momentary machine coordinates are stored as the position of the measurement point. At the same time, the axial movement by manual handle feed or jog feed stops.

Until the skip signal is brought to “0”, the interlock prevents the movement in the direction in which the measurement probe was brought to the current measurement point.

Signal addresses

	#7	#6	#5	#4	#3	#2	#1	#0
X004	SKIP							
G039	GOQSM	WOQSM	OFN5	OFN4	OFN3	OFN2	OFN1	OFN0
G040					OFN9	OFN8	OFN7	OFN6

Parameter

	#7	#6	#5	#4	#3	#2	#1	#0
5005			QNI					

[Data type] Bit

QNI When the tool length measurement B function is executed, a tool offset number is selected:

0 : According to the selection the operator makes on an MDI unit (by moving the cursor).

1 : According to the signal input from the PMC.

	#7	#6	#5	#4	#3	#2	#1	#0
5007			WMC	WMH	WMA	TMA	TC3	TC2

[Data type] Bit**TC3, TC2**

TC3	TC2	Description
0	0	The tool-change position is determined by the first reference position return.
0	1	The tool-change position is determined by the second reference position return.
1	0	The tool-change position is determined by the third reference position return.
1	1	The tool-change position is determined by the fourth reference position return.

TMA 0 : The tool length can be measured only on the Z-axis.

1 : The tool length can be measured on any axis.

WMA 0 : The workpiece origin offset from the reference plane can be measured only on the Z-axis.

1 : The workpiece origin offset from the reference plane can be measured on any axis.

WMH 0 : The workpiece origin offset from the reference hole cannot be measured.

1 : The workpiece origin offset from the reference hole can be measured.

WMC 0 : The axis of workpiece origin offset measurement is specified by entering the axis name.

1 : The axis of workpiece origin offset measurement is selected by moving the cursor.

This parameter is valid when the WMA bit (bit 3 of parameter 5007) is set to 1.

5022 Distance from the reference tool tip position to the base measurement surface

[Data type] 2-word axis

	Increment system		
	IS-A	IS-B	IS-C
Millimeter machine	0.01 mm	0.001 mm	0.0001 mm
Inch machine	0.001 inch	0.0001 inch	0.00001 inch

The distance L from the reference tool tip position to the base measurement surface with the machine placed at the machine zero point is set for each axis.

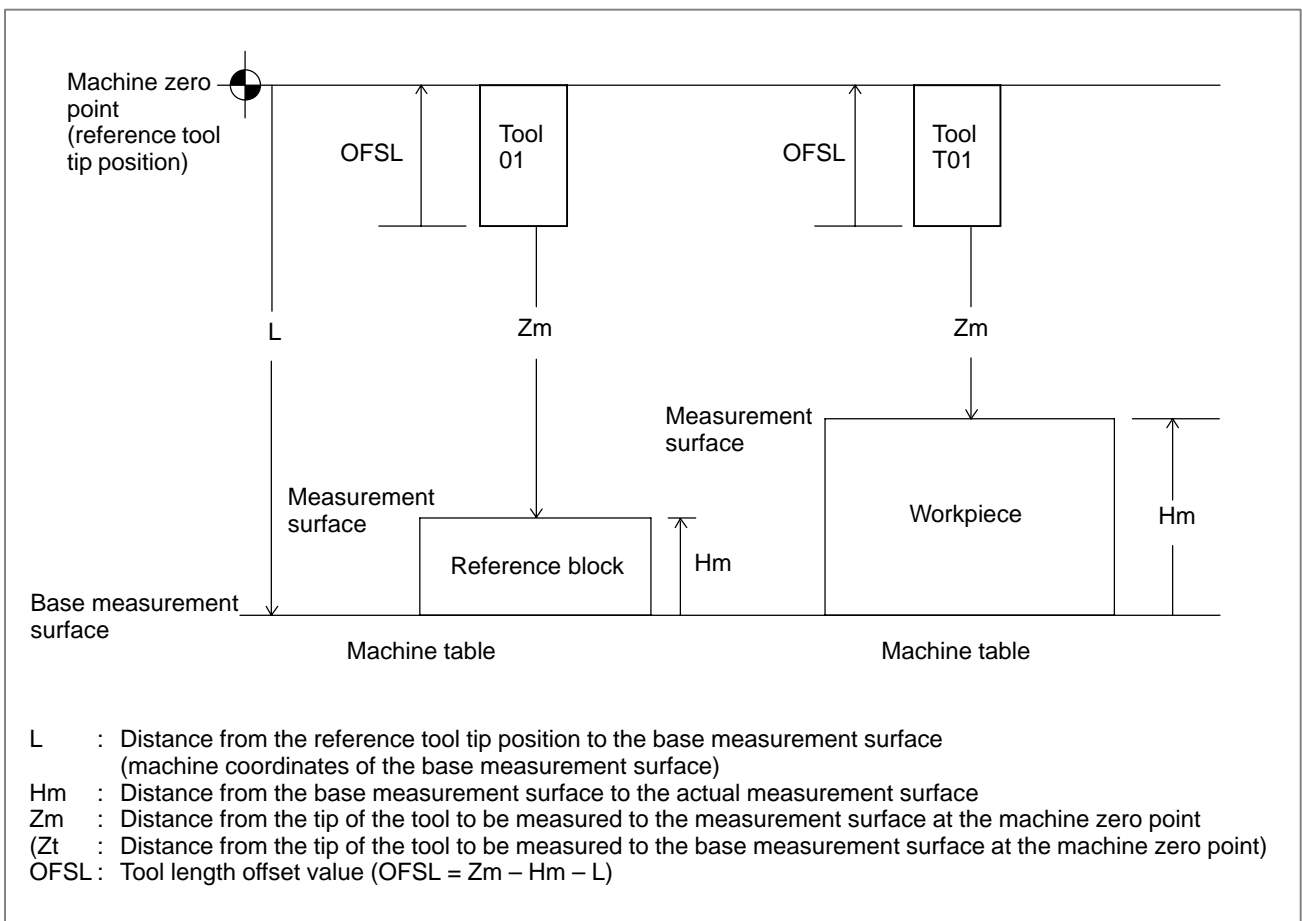

Reference item

Series 16i/18i/160i/180i/ 160is/180is	OPERATOR'S MANUAL (For Machining Center) (B-63534EN)	III.11.4.14	Tool length/workpiece origin measurement B
---	--	-------------	---

15

PMC CONTROL FUNCTION



15.1 PMC AXIS CONTROL

15.1.1 PMC Axis Control

General

The PMC can directly control any given axis, independent of the CNC. In other words, moving the tool along axes that are not controlled by the CNC is possible by entering commands, such as those specifying move distance and feedrate, from the PMC. This enables the control of turrets, pallets, index tables and other peripheral devices using any given axes of the CNC.

Whether the CNC or PMC controls an axis is determined by the input signal provided for that particular axis.

The PMC can directly control the following operations:

- (1) Rapid traverse with move distance specified
- (2) Cutting feed – feed per minute, with move distance specified
- (3) Cutting feed – feed per revolution, with move distance specified
- (4) Skip – feed per minute, with move distance specified
- (5) Dwell
- (6) Continuous feed
- (7) Reference position return
- (8) 1st reference position return
- (9) 2nd reference position return
- (10) 3rd reference position return
- (11) 4th reference position return
- (12) External pulse synchronization – Main spindle
- (13) External pulse synchronization – first manual handle
- (14) External pulse synchronization – second manual handle
- (15) External pulse synchronization – third manual handle (for M series only)
- (16) Feedrate control
- (17) Auxiliary function, Miscellaneous function 2, Miscellaneous function 3
- (18) Selection of the machine coordinate system
- (19) Torque control

The PMC is provided with four paths to control these operations using input and output signals.

By issuing commands through these four paths, the PMC can simultaneously control multiple separate axes. Use parameter No. 8010 to determine which path controls which axis. Commands may be issued through one path to two or more axes, thus allowing the PMC to control multiple axes using one path.

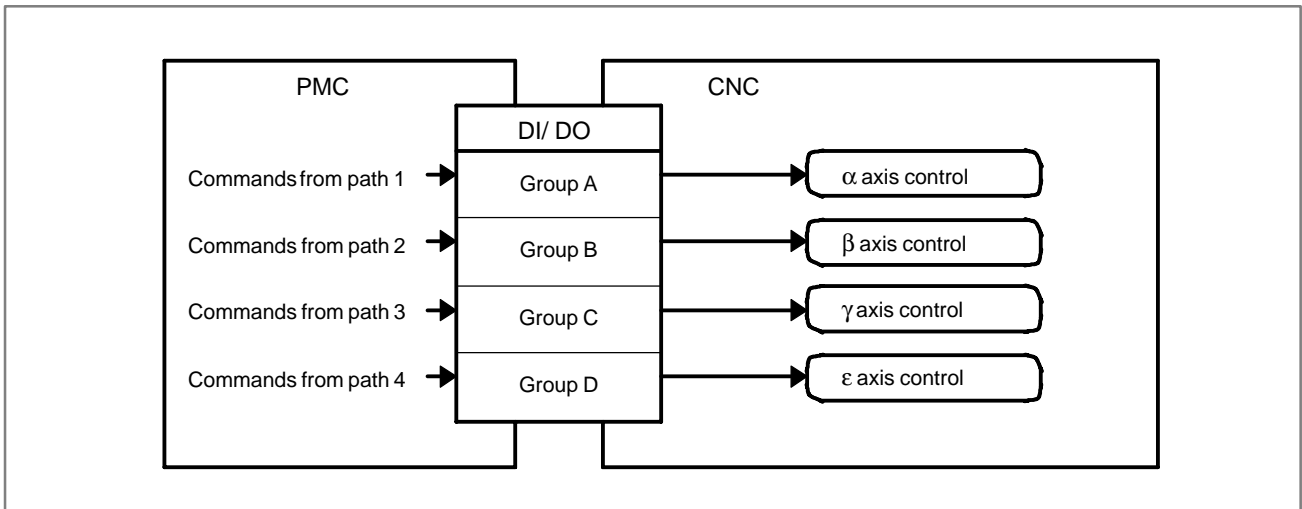

In the following description, input/output signals from the four paths are called group A (path 1), group B (path 2), group C (path 3), and group D (path 4), respectively.

The name of an input/output signal used for PMC axis control always contains a lowercase “g”, as in EBUFg. However, there is no such signal as EBUFg. The actual signal names represented by EBUFg are EBUFA, EBUFB, EBUFC, and EBUFD, which respectively correspond to signals of group A (path 1), group B (path 2), group C (path 3), and group D (path 4).

Basic procedure

- (1) In parameter No. 8010, specify which DI/DO signal group (A, B, C, or D) is to be used for PMC axis control on a per-axis basis.

When using the same group for simultaneously controlling two or more axes, check that the settings of the parameters related to feedrate (rapid traverse rate, acceleration/deceleration time constant, diameter/radius, linear axis/rotation axis, etc.) are identical for each axis to be controlled.

- (2) To enable direct PMC axis control, set each control axis selection signal (EAX1 to EAX8), that corresponds to an axis to be controlled, to 1.
- (3) Determine the operation.

The axis control command signals (EC0g to EC6g) specify the type of operation. The axis control feedrate signals (EIF0g to EIF15g) specify the feedrate. The axis control data signals (EID0g to EID31g) specify the moving distance and other data.

These signals, together with block stop prohibition signal EMSBKg (described later), determine one complete operation, which is tantamount to one block executed during CNC-controlled automatic operation. These signals may be collectively called the axis control block data signals.

⊙ List of Signals Determining Data, Tantamount to One Block for PMC Axis Control

Generic name	Signal name	Symbol	Data type
Axis control block data signals	Block stop prohibition signal	EMSBKg	Bit
	Axis control command signal	EC0g to EC6g	Byte
	Axis control feedrate signal	EIF0g to EIF15g	Word
	Axis control data signal	EID0g to EID31g	Two-word

- (4) When the data governing a complete operation (one block) is determined, reverse the logical state of the axis control command read signal EBUFg (i.e., from “0” to “1” or vice versa). Note that, for this to occur, axis control command read completion signal EBSYg must be in the same logical state as EBUFg.
- The CNC is capable of storing axis control functions from the PMC in its buffer so that multiple operations can be performed in series, under the control of the PMC. This allows the CNC to accept a new command block from the PMC during the execution of another block if the buffer has free space.

The following figure illustrates an example in which command [1] is being executed, commands [2] and [3] are stored in the buffers, and command [4] has been issued (the axis control block data signal is set).

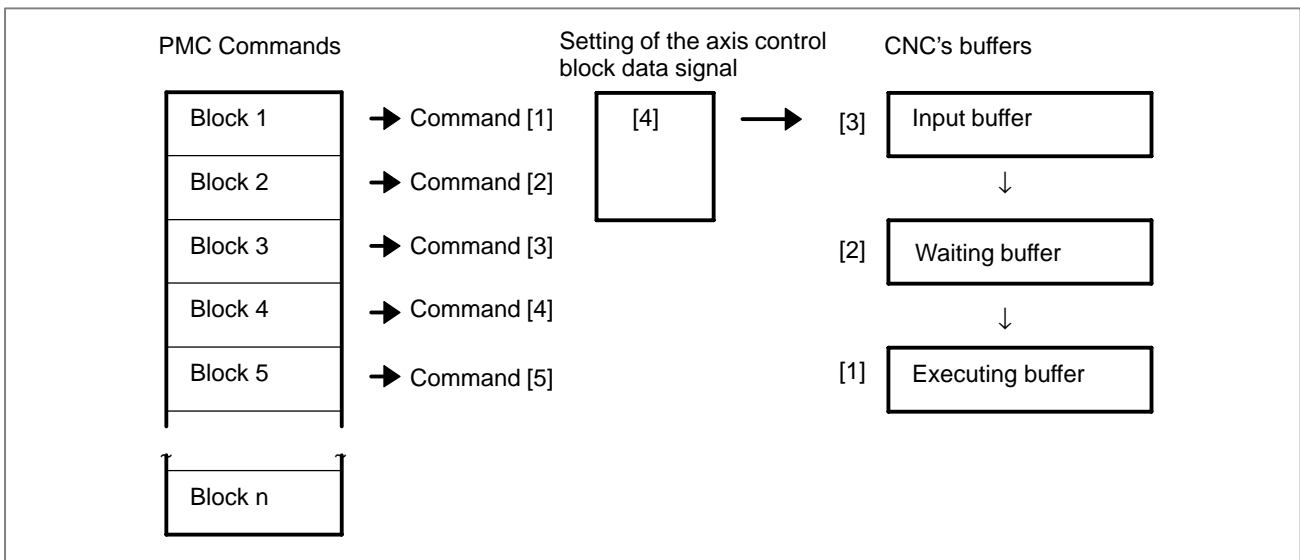

When the execution of command [1] is completed:

- command [2] is transferred from the waiting buffer to the executing buffer;
- command [3] is transferred from the input buffer to the waiting buffer; and
- command [4] is transferred to the input buffer as the command block (axis control block data signal).

After the reception of command [4] by the input buffer, the PMC can issue command [5] to the CNC (the axis control block data signal is set).

The timing chart for the command operation is shown below.

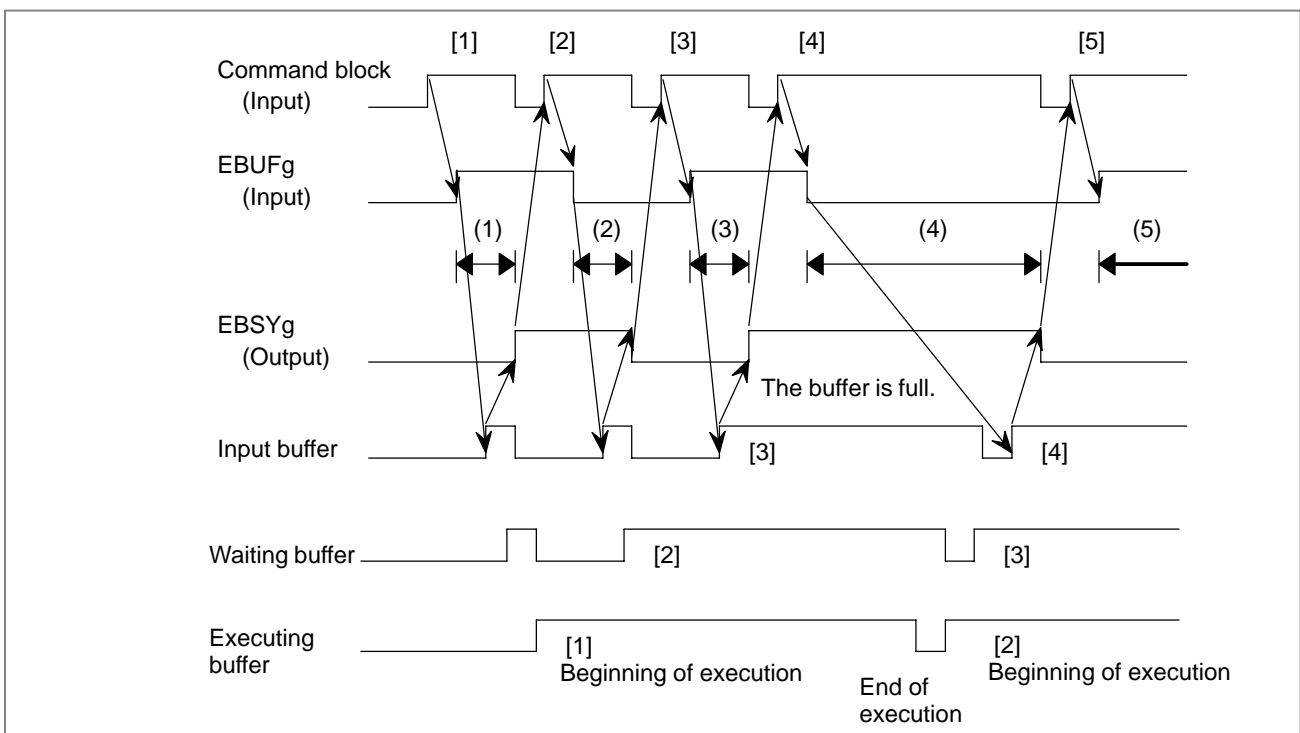

(1), (2), (3), (4), (5) : A new block cannot be issued during these intervals (while EBUFg and EBSYg are in different logical states).

- The status of the CNC buffer can be determined by the exclusive OR of the axis control command read signal EBUFg, input from the PMC, and axis control command read completion signal EBSYg, output from the CNC.

EBUFg EBSYg	Exclusive OR (XOR)	CNC buffer status
0 1 0 1	0	The previous block has already been read into the CNC buffer. The PMC can issue the next block.
0 1 1 0	1	The previous block has not yet been read completely. It is just being read or waiting for the CNC buffer to become available. Do not issue the next block, nor reverse the logical state of EBUFg. Reversing the EBUFg state invalidates any block that has been already issued.

- (5) Repeat steps (3) and (4) until all the blocks have been issued.

When the final block has been issued, set control axis selection signals EAX1 to EAX8 to “0”. Before setting these signals to “0”, however, check that the blocks stored in the CNC’s input, waiting, and executing buffers have all been executed. Setting the signals to “0” while a block is being executed, or while a block remains in any of these buffers, results in the issue of a P/S alarm. This alarm suspends the current block execution and invalidates the blocks stored in the input and waiting buffers.

To ensure no block is being executed, or that there are no blocks remaining in the input or waiting buffer, check that control axis selection status signal *EAXSL is set to “0”.

For those axes that are always subject to PMC control, such as those controlling turrets, pallets, and ATCs, ensure that the EAX1 to EAX8 signals are always set to “1”. There is no need to set these signals to “0” after issuing commands from the PMC to the CNC. When all command blocks have been executed (there are no blocks remaining to be executed), the CNC automatically stops execution.

- (6) When control axis selection signals EAX1 to EAX8 are set from “1” to “0”, control is returned to the CNC.

Signal

Signal list

No.	Symbol	Signal name
1	EAX1 to EAX8	Control axis selection signals
2	EC0g to EC6g	Axis control command signals
3	EIF0g to EIF15g	Axis control feedrate signals
4	EID0g to EID31g	Axis control data signals
5	EBUFg	Axis control command read signal
6	EBSYg	Axis control command read completion signal
7	ECLRg	Reset signal
8	ESTPg	Axis control temporary stop signal
9	ESBKg	Block stop signal
10	EMSBKg	Block stop disable signal
11	EM11g to EM48g	Auxiliary function code signals
12	EMFg	Auxiliary function strobe signal
13	EMF2g	Miscellaneous function 2 strobe signal
14	EMF3g	Miscellaneous function 3 strobe signal
15	EFINg	Auxiliary function completion signal
16	ESOFg	Servo-off signal

No.	Symbol	Signal name
17	EMBUFg	Buffering disable signal
18	*EAXSL	Control axis selection status signal
19	EINPg	In-position signal
20	ECKZg	Following zero checking signal
21	EIALg	Alarm signal
22	EGENg	Axis moving signal
23	EDENg	Auxiliary function executing signal
24	EOTNg	Negative-direction overtravel signal
25	EOTPg	Positive-direction overtravel signal
26	*FV0E to *FV7E	Feedrate override signals
27	OVCE	Override cancellation signal
28	ROV1E, ROV2E	Rapid traverse override signals
29	DRNE	Dry run signal
30	RTE	Manual rapid traverse selection signal
31	EOV0	Override 0% signal
32	ESKIP	Skip signal
33	EADEN1 to EADEN8	Distribution completion signals
34	EABUFg	Buffer full signal
35	EACNT1 to EACNT8	Controlling signals
36	*+ED1 to *+ED8 *-ED1 to *-ED8	External deceleration signal
37	ELCKZg	Accumulated zero check signal
38	TRQMx	Torque control mode signal

Signal Detail

1 Control axis selection signals EAX1 to EAX8

[Classification] Input signal

[Function] When the signal is set to “1”, the corresponding axis becomes subject to PMC control.

When the signal is set to “0”, PMC control becomes invalid. Changing the setting of the control axis selection signal is possible only when control axis selection status signal *EAXSL is set to “0”. Changing the setting when *EAXSL is set to “1” results in the issue of a P/S alarm (No. 139). Alarm signal EIALg is set to “1”.

When NCC, bit 5 of parameter No. 8001, is set to “0”, a command issued from the CNC is executed while the control axis selection signal is set to “1” and signal *EAXSL is set to “0”. When the parameter is set to “1”, the same attempt results in the issue of a P/S alarm (No. 139). Note that the command is invalidated when the tool is moving along the axis in manual continuous feed mode.

If the control axis selection signal is set to “1” while the CNC is currently executing a command, a P/S alarm is generated. In manual continuous feed mode, setting this signal to “1” suspends the execution of the command. While *EAXSL is set to “0”, the status of alarm signal EIALg does not change to 1 when the control axis selection signal is set to 1 and a P/S alarm (No. 139) is generated. In this case, the axis can be controlled from the PMC, even when the CNC is in the alarm status.

NOTE

After setting control axis selection signals EAX1 to EAX8 to 1, it takes at least 8 msec before the PMC can issue commands to the CNC.

2 Axis control command signals EC0g to EC6g

[Classification] Input signal

[Function] Specifies the following operations through each path.

Axis control command (hexadecimal code)	Operation
00h	Rapid traverse (linear acceleration/deceleration)
	Performs the same operation as G00, used by the CNC.
01h	Cutting feed – feed per minute (exponential acceleration/deceleration or linear acceleration/deceleration after interpolation)
	Performs the same operation as G94 G01, used by the CNC.

Axis control command (hexadecimal code)	Operation
02h	Cutting feed – feed per revolution (exponential acceleration/deceleration or linear acceleration/deceleration after interpolation)
	Performs the same operation as G95 G01, used by the CNC.
03h	Skip – feed per minute
	Performs the same operation as G31 G01, used by the CNC.
04h	Dwell
	Performs the same operation as G04, used by the CNC.
05h	Reference position return
	Moves the tool in the direction of reference position return specified by ZMlx, bit 5 of parameter No. 1006, in rapid traverse mode, then performs the same operation as manual reference position return, done by the CNC.
06h	Continuous feed (exponential acceleration/deceleration)
	Moves the tool in the specified direction in jog feed mode. Performs the same operation as that of JOG feed, done by the CNC.
07h	1st reference position return
	Performs the same operation as done when positioning the tool to the reference position from the intermediate point specified by G28 of the CNC.
08h	2nd reference position return
	Performs the same operation as done when positioning the tool to the reference position from the intermediate point specified by G30 P2 of the CNC.
09h	3rd reference position return
	Performs the same operation as done when positioning the tool to the reference position from the intermediate point specified by G30 P3 of the CNC.
0Ah	4th reference position return
	Performs the same operation as done when positioning the tool to the reference position from the intermediate point specified by G30 P4 of the CNC.
0Bh	External pulse synchronization – main spindle
	Synchronizes with the main spindle.
0Dh	External pulse synchronization – 1st manual handle
	Synchronizes with the 1st manual handle.

Axis control command (hexadecimal code)	Operation
0Eh	External pulse synchronization – 2nd manual handle
	Synchronizes with the second manual handle.
0Fh	External pulse synchronization – 3rd manual handle
	Synchronizes with the 3rd manual handle.
10h	Speed command (linear acceleration/deceleration)
	Performs continuous feed at the specified speed.
11h	Torque control
	Continuous feed under torque control
12h	Auxiliary function
	Performs the same function as the miscellaneous function (M function), used by the CNC.
14h	Miscellaneous function 2
	Similar to the miscellaneous function of the CNC
15h	Miscellaneous function 3
	Similar to the miscellaneous function of the CNC
20h	Machine coordinate system selection
	Performs the same operation as G53, used by the CNC.

Rapid traverse rate

When using the rapid traverse command (EC0g to EC6g: 00h), the feedrate can be specified in either the same parameter as that used by the CNC (No. 1420) or the PMC's axis interface feedrate signals EIF0g to EIF15g. This can be set with RPD, bit 0 of parameter No. 8002.

Feed per revolution

When using the cutting feed – feed per revolution command (EC0g to EC6g: 02h), the optional function for threading in synchronous feed mode is necessary in the case of the M series.

This operation cannot be performed when IT0 to IT2, bit 4 to 6 of parameter No. 7501, specify high-speed cycle machining.

Reference without dogs position return

The reference position return command (EC0g to EC6g: 05h) enables the following operation: When DLZ, bit 1 of parameter No. 1002, specifying reference position return without dogs for all axes, or DLZx, bit 1 of parameter No. 1005, specifying reference position return without dogs for each axis, is valid and the tool has not been returned to the reference position since the power was turned on, move each axis in the direction specified by the continuous feed command (EC0g to EC6g: 06h) (position the tool to a point near the reference position) and issue the reference position return command (EC0g to EC6g: 05h). This returns the tool to the reference position (positions the tool to the grid nearest the current position) without using the deceleration signal for reference position return.

Note that, when positioning the tool to a point near the reference position, the tool must be moved in the direction of reference position return at such a speed that the servo position error exceeds the value of parameter No. 1836.

The direction of the grid relative to the proximate position depends on ZMIx, bit 5 of parameter No. 1006.

After the reference position has been established, reference position return can be performed at high speed by issuing the reference position return command (EC0g to EC6g: 05h), irrespective of the reference position return direction specified by ZMIx, bit 5 of parameter No. 1006.

First reference position return for an incomplete reference position return without dogs

When using the 1st reference position return command (EC0g to EC6g: 07h), if DLZ, bit 1 of parameter No. 1002, specifying reference position return without dogs for all axes, or DLZx, bit 1 of parameter No. 1005, specifying reference position return without dogs on a per-axis basis is valid and the tool has not been returned to the reference position since the power was turned on, issuing the 1st reference position return command (EC0g to EC6g: 07h) results in the issue of a P/S alarm (No. 090).

1st to 4th reference position return

When using the 1st to 4th reference position return commands (EC0g to EC6g: 07h to 0Ah), the feedrate can be specified using RPD, bit 0 of parameter No. 8002, in the same manner as when using the rapid traverse command (EC0g to EC6g: 00h).

Note that, in the case of the 1st reference position return, if the tool has not been manually returned to the reference position after the power was turned on, the feedrate specified by parameter No. 1424 applies.

External pulse synchronization

When using the external pulse synchronization commands (EC0g to EC6g: 0Bh, 0Dh to 0Fh), the tool moves backwards if the external pulse has a negative value. When a manual handle interrupt is executed for the axis to which the external pulse is being applied, the moving distance is the sum of the external pulse and the interrupt pulse.

When a serial spindle is used, synchronization with the main spindle (EC0g to EC6g: 0Bh) is not possible.

Display of remaining distance

When using the continuous feed command (EC0g to EC6g: 06h) and the external pulse synchronization command (EC0g to EC6g: 0Bh, 0Dh to 0Fh), the displayed remaining distance is always "0".

Speed command

When using the speed command (EC0g to EC6g: 10h), specify the axis to be controlled as a rotation axis in ROTX, bit 0 of parameter No. 1006.

While position control is being executed for the continuous feed command (EC0g to EC6g: 06h), the speed command (EC0g to EC6g: 10h) exerts speed control over the servo motor, thus allowing the speed to be dynamically changed during continuous feed. This makes this command suitable for driving a rotation tool with a servo motor.

A linear acceleration/deceleration time constant can be set for each axis, using parameter No. 8028.

Note that, while jog feed is being executed by the speed command, no coordinate system values are changed. This will result in the loss of the tool position. Therefore, after continuous feed has been completed, always return the tool to the reference position before executing a move command.

Machine coordinate system selection

The machine coordinate system selection command (EC0g to EC6g: 20h) performs absolute positioning to move the tool in rapid traverse to a specified position on the machine coordinate system. This command is used to move the tool to a position specifically defined for the machine, such as the tool change position.

This command can be used, irrespective of whether the optional function for workpiece coordinate system setting is provided.

For a rotation axis, short cut rotation can also be specified. When using this command for a T series, cancel the tool offset and the tool nose radius compensation. For a M series, cancel cutter compensation, tool length compensation, and tool offset.

The machine coordinate system must be set before attempting to use this command. After turning on the power, return the tool to the reference position either manually or by using G28. When an absolute position detector is provided, returning the tool to the reference position is not necessary because the tool position will be stored in memory.

Torque control command

When torque control is selected (EC0g to EC6g: 11h), the PMC controlled axis can be subjected to torque control instead of position control. In the torque control mode, the servo motor outputs the torque specified by the NC.

(1) Switching from position control to torque control**a. Setting a torque control axis**

Set the axis to be subjected to torque control in the TRQMx bit (bit 7 of parameter No. 2007). Also set the torque control axis in parameter No. 2105 of the torque constant. The motor-specific standard value is automatically set in this parameter when the power is turned on with the DGPR bit (bit 1 of parameter No. 2000) set to 0.

b. Position management in torque control mode

In torque control mode, choosing whether to perform follow-up can be selected by setting the TQF bit (bit 4 of parameter No. 1803).

When follow-up is not performed, an integrated travel value (error count) exceeding the value of parameter No. 1885 causes servo alarm 423 to be issued. When torque control is switched to position control, follow-up is always performed, even if follow-up suppression is selected.

The CNC manages the position even in torque control mode. After torque control is switched to position control, no reference position return is necessary.

c. Traveling direction and speed in torque control mode

In torque control mode, the torque specified by the axis control data signal is output. While there is no target of torque generation or while the output torque falls below the specified torque, the traveling direction is determined by the plus or minus sign added to the torque data, as in position control. When the traveling speed exceeds the specified speed, servo alarm 422 is issued.

d. Timing of switching to torque control

A mode is switched to torque control mode after the position error enters the effective range (in-position state).

(2) Switching from torque control to position control
(canceling torque control mode)

Torque control mode is canceled when any of the following conditions is satisfied:

- 1) The reset signal ECLRg is brought to "1".
- 2) A servo alarm is issued.
- 3) An OT alarm is issued on the torque control axis.
- 4) An emergency stop occurs.
- 5) The servo motor is turned off by the servo off signal ESOFg.

a. Timing for canceling torque control

When torque control by the PMC controlled axis is canceled, follow-up may or may not be performed, depending on the setting in the TRF bit (bit 4 of parameter No. 1803). If follow-up is suppressed, the torque control mode signal TRQMx immediately goes "0" when a condition to cancel torque control is detected. Then, position control mode is selected. The execution terminates when the position error enters the effective range. If follow-up is performed, the torque control mode signal TRQMx goes "0" when a condition to cancel torque control is detected. Then, follow-up starts. When the position error falls below or equals the cancel limit value specified in parameter 1886, position control mode is selected. The execution terminates when the position error enters the effective range.

b. Command after torque control mode is canceled

When torque control mode is canceled, normal position control mode is selected. In torque control mode, the position is managed, and the machine coordinates are not displaced. The workpiece coordinates, however, are shifted from the machine coordinates. The shift must be canceled by specifying the command for setting the workpiece coordinate system or similar function.

CAUTION

- 1 If the torque control axis may be moved in torque control mode, the follow-up parameter TQF (bit 4 of parameter No. 1803) must be set to "1".
- 2 If torque control mode is canceled while the torque control axis is moving, the return to position control mode causes a mechanical impact. A faster movement causes a greater impact. To cancel torque control mode, decelerate or stop the movement in advance.
- 3 When specifying the torque control command after a manual reference position return is completed, set the feed direction selection signal to "0" in advance. Alternatively, select a mode other than manual reference position return mode in advance.
- 4 In torque control mode, never detach a controlled axis by the controlled axis detach signal DTCHx or by a setting parameter.

The following table shows the correspondence between the axis control commands and their data:

Command block		
Operation	Axis control code signal EC0g to EC6g	Command data
Rapid traverse	00h	Total moving distance EID0g to EID31g Rapid traverse rate EIF0g to EIF15g The rapid traverse rate is valid when PRD, bit 0 of parameter No. 8002, is set to "1".
Cutting feed – feed per minute	01h	Total moving distance EID0g to EID31g Feedrate
Skip – feed per minute	03h	EIF0g to EIF15g
Cutting feed – feed per revolution	02h	Total moving distance EID0g to EID31g Feed per rotation EIF0g to EIF15g
Dwell	04h	Dwell time EID0 to EID31g
Reference position return	05h	None
Jog feed	06h	Feed direction EID31g Jog feedrate EIF0g to EIF15g

Operation	Axis control code signal EC0g to EC6g	Command data
1st reference position return	07h	Rapid traverse rate EIF0g to EIF15g The rapid traverse rate is valid when PRD, bit 0 of parameter No. 8002, is set to "1".
2nd reference position return	08h	
3rd reference position return	09h	
4th reference position return	0Ah	
External pulse synchronization – main spindle	0Bh	Pulse weight EIF0g to EIF15g
External pulse synchronization – manual handle	0Dh	
	0Eh	
	0Fh <For M series only>	
Speed command	10h	Continuous feed EIF0g to EIF15g
Torque control	11h	Maximum feedrate, EIF0g to EIF15g Torque data, EID0g to EID31g
Auxiliary function	12h	Auxiliary function code EID0g to EID15g
Miscellaneous function 2	14h	Miscellaneous function code, EID0g to EID15g
Miscellaneous function 3	15h	Miscellaneous function code, EID0g to EID15g
Machine coordinate system setting	20h	Machine coordinate system setting (absolute value) EID0g to EID31g Rapid traverse rate EIF0g to EIF15g The rapid traverse rate setting is effective when bit 0 (RPD) of parameter No. 8002 is set to "1".

3 Axis control feedrate signals EIF0g to EIF15g

[Classification] Input signal

- [Function] (1) Rapid traverse (EC0g to EC6g: 00h)
 (2) 1st reference position return (EC0g to EC6g: 07h)
 (3) 2nd reference position return (EC0g to EC6g: 08h)

- (4) 3rd reference position return (EC0g to EC6g: 09h)
- (5) 4th reference position return (EC0g to EC6g: 0Ah)
- (6) Machine coordinate system selection (EC0g to EC6g: 20h)

For these commands, signals EIF0g to EIF15g are used to specify the rapid traverse rate, in binary format, when bit 0 (RPD) of parameter No. 8002 is set to "1". For 1st reference position return, however, the rapid traverse rate specified with parameter No. 1424 is used if manual reference position return has not been performed after the power was first turned on.

[Unit of data]

		Data unit		Unit
		IS-B	IS-C	
Linear axis	Metric machine	1		mm/min
	Inch machine	0.1		inch/min
Rotation axis		1		deg/min

[Valid data range] Specify data within the range given in the following table.

		Data range		Unit
		IS-B	IS-C	
Linear axis	Metric machine	30 to 15000	30 to 12000	mm/min
	Inch machine	30 to 6000	30 to 4800	inch/min
Rotation axis		30 to 15000	30 to 12000	deg/min

- (7) Cutting feed – feed per minute (EC0g to EC6g: 01h)
- (8) Skip – feed per minute (EC0g to EC6g: 03h)

For these commands, the signals are used to specify, in binary format, the feedrate along an axis. The specified feedrate can be magnified by ten by the setting of bit 3 (F10) of parameter No. 8002.

[Unit of data] When bit 3 (F10) of parameter No. 8002 is set to 0

		Data unit		Unit
		IS-B	IS-C	
Linear axis	Metric machine	1	0.1	mm/min
	Inch machine	0.01	0.01	inch/min
Rotation axis		1	0.1	deg/min

When bit 3 (F10) of parameter No. 8002 is set to 1

		Data unit		Unit
		IS-B	IS-C	
Linear axis	Metric machine	10	1	mm/min
	Inch machine	0.1	0.01	inch/min
Rotation axis		10	1	deg/min

[Valid data range] 1 to 65535

(Actual values must fall within the ranges given in the following table.)

		Data range		Unit
		IS-B	IS-C	
Linear axis	Metric machine	1 to 100000	0.1 to 12000.0	mm/min
	Inch machine	0.01 to 4000.00	0.001 to 480.000	inch/min
Rotation axis		1 to 100000	0.1 to 12000.0	deg/min

CAUTION

When "0" is specified, the CNC continues to perform buffering without moving the tool. In such a case, release the buffering by issuing reset signal ECLRg. Cutting feedrate clamp is disabled.

(9) Cutting feed – feed per rotation (EC0g to EC6g: 02h)

For this command, the signals are used to specify the amount by which the tool is moved for every rotation of the spindle.

<For T series>

[Unit of data] The data increment depends on the settings of bits 6 (FR1) and 7 (FR2) of parameter No. 8002, as listed in the following table.

Parameter		Metric input (mm/rev)	Inch input (inch/rev)	Rotation axis (deg/rev)
FR2	FR1			
1	1	0.0001	0.000001	0.0001
0	0			
0	1	0.001	0.00001	0.001
1	0	0.01	0.0001	0.01

[Valid data range] 1 to 65535

(Actual values must fall within the ranges given in the following table.)

		Data range		Unit
		IS-B	IS-C	
Linear axis	Metric input	0.0001 to 500.0000		mm/rev
	Inch input	0.000001 to 9.999999		inch/rev
Rotation axis		0.0001 to 500.0000		deg/rev

<For M series>

[Unit of data] The data unit depends on the settings of bits 6 (FR1) and 7 (FR2) of parameter No. 8002, as listed in the following table.

Parameter		Metric input (mm/rev)	Inch input (inch/rev)	Rotation axis (deg/rev)
FR2	FR1			
1	1	0.01	0.0001	0.01
0	0			
0	1	0.1	0.001	0.1
1	0	1	0.01	1

[Valid data range] 1 to 65535

(Actual values must fall within the ranges given in the following table.)

		Data range		Unit
		IS-B	IS-C	
Linear axis	Metric input	0.01 to 500.00		mm/rev
	Inch input	0.0001 to 9.9999		inch/rev
Rotation axis		0.01 to 500.00		deg/rev

WARNING

- 1 The value of parameter No. 8022 is used as the upper limit for clamping the feedrate.
- 2 Override for the feedrate is effective. Dry run is invalid.

CAUTION

The specified feedrate can be magnified by 1, 10, or 100 by setting bits 6 (FR1) and 7 (FR2) of parameter No. 8002 accordingly.

- (10) External pulse synchronization – main spindle
(EC0g to EC6g: 0Bh)
- (11) External pulse synchronization – first manual handle
(EC0g to EC6g: 0Dh)
- (12) External pulse synchronization – second manual handle
(EC0g to EC6g: 0Eh)
- (13) External pulse synchronization – third manual handle
(EC0g to EC6g: 0Fh)

For these commands, the signals are used to specify the weight of the external pulses. A weight range of $\pm 1/256$ to ± 127 can be set by using signals EIF0g to EIF7g for the figures after the decimal point. When a negative weight is specified, the tool is moved in the reverse direction. When a new pulse weight is specified while the tool is moving in synchronization with external pulses, inverting signal EBUFg causes the tool to move with the new pulse weight.

As commands for (10) to (13) are executed without buffering, axis control command read completion signal EBSYg usually need not be checked.

CAUTION

The pulse weight is clamped according to the value set for parameter No. 1424 (parameter for the manual rapid traverse rate for each axis).

NOTE

When diameter programming is specified with bit 3 (DIAx) of parameter No. 1006, bit 1 (CDI) of parameter No. 8005 can be used to specify whether a radius or diameter is to be used in a command.

(14) Continuous feed (EC0g to EC6g: 06h)

Set the feedrate as the same as for cutting feed – feed per minute (EC0g to EC6g: 01h). The feedrate can be changed during continuous feed.

Specify the feedrate with signals EIF0g to EIF15g, and invert the axis control command read signal EBUFg during continuous feed, then the tool moves at the new feedrate.

As commands for jog feed are executed without buffering, axis control command read completion signal EBSYg usually need not be checked.

The specified feedrate can be magnified by 10 by setting bit 3 (F10) of parameter No. 8002, and by 200 by setting bit 2 (JFM) of parameter No. 8004.

- Maximum feedrate (with override of 254%)

	IS-B		IS-C	
	Metric input	Inch input	Metric input	Inch input
Magnified by 1	166458mm/min	1664.58inch/min	16645mm/min	166.45inch/min
Magnified by 10	1664589mm/min	16645.89inch/min	166458mm/min	1664.58inch/min
Magnified by 200 (Note 1)	1966050mm/min	1966605.00inch/min	196605mm/min	19660.50inch/min

CAUTION

The maximum feedrate depends on whether override is applied or canceled. The following table lists the maximum feedrate when override is canceled.

	IS-B		IS-C	
	Metric input	Inch input	Metric input	Inch input
Magnified by 1	65535 mm/min	655.35 inch/min	6553 mm/min	65.53 inch/min
Magnified by 10	655350 mm/min	6553.50 inch/min	65535 mm/min	655.35 inch/min
Magnified by 200	13107000 mm/min	131070.00 inch/min	1310700 mm/min	13107.00 inch/min

NOTE

- 1 Magnification of 200 is valid only for the continuous feed command (EC0g to EC6g: 06h).
- 2 The actual speed may not be displayed correctly, depending on the feedrate.

(15) Speed command (EC0g to EC6g: 10h)

For this command, the signals are used to specify, in binary format, the servo motor speed.

Specify a positive value for rotation in the forward direction. Specify a negative value (twos complement) for rotation in the reverse direction.

When a new servo motor speed is specified, inverting the axis control command read signal EBUFg accelerates or decelerates the servo motor until it attains the new speed.

Data range	Unit
-32768 to +32767	min ⁻¹

NOTE

The servo motor speed may contain a slight error, as follows:

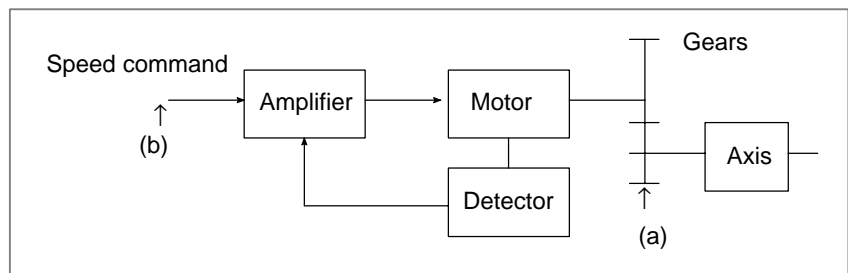

- (a) The speed command for PMC axis control requires the specification of the servo motor speed, not the feedrate along an axis. To specify a feedrate along the axis when gears are used to link the servo motor and axis, the feedrate must be converted to a rotation speed of the servo motor speed. As the motor speed must be specified with an integer, the converted speed is subject to a round-off error.
- (b) The minimum increment for specifying the motor speed is calculated by the following formula and rounded to the nearest integer:

$$F_{\min} = \frac{P \times 2}{15} \times \frac{1}{1000}$$

F_{\min} : Minimum increment for the motor speed

P : Number of pulses per rotation of the detector for velocity feedback

Specify the speed command using the value calculated by the following formula:

$$F = \frac{N \times P \times 2}{15} \times \frac{1}{1000}$$

F : Speed command value (integer)

N : Servo motor speed (min^{-1})

P : Number of detector pulses issued per rotation for velocity feedback

NOTE

In speed command mode, the speed after acceleration/deceleration is specified to the servo control unit. The loop gain for position control is invalid.

- (16) When a torque control command (EC0g to EC6g: 11h) is specified Specify the maximum speed in torque control mode, in min^{-1} .

A servo alarm (No. 422) is issued if there is no object for which a torque is to be generated or if the feedrate exceeds the specified value while torque control is being applied.

The maximum feedrate in torque control mode can be changed in torque control mode by setting the new feedrate data in the signal then inverting the logic of axis control command read signal EBUFg.

Valid data range	Units
1 to 32767	min^{-1}

NOTE

The data units will be cm/min when a linear motor is being used.

4 Axis control data signals EID0g to EID31g

[Classification] Input signal

[Function]

[Unit of data]

	IS-B	IS-C	Unit
Metric input Degree input	0.001	0.0001	mm deg
Inch input	0.0001	0.00001	inch

[Valid data range]

- (1) Rapid traverse (EC0g to EC6g: 00h)
- (2) Cutting feed – feed per minute (EC0g to EC6g: 01h)
- (3) Cutting feed – feed per rotation (EC0g to EC6g: 02h)
- (4) Skip – feed per minute (EC0g to EC6g: 03h)

For these commands, signals EID0g to EID31g are used to specify, in binary format, the incremental moving distance, according to the input increment used for the axis.

	IS-B	IS-C	Unit
Metric input Degree input	± 99999.999	± 9999.9999	mm deg
Inch input	± 9999.9999	± 999.99999	inch

When diameter programming is specified with bit 3 (DIAx) of parameter No. 1006, bit 1 (CDI) of parameter No. 8005 can be used to specify whether a radius or diameter is to be used in a command.

- (5) Dwell (EC0g to EC6g: 04h)

For this command, the signals are used to specify, in binary format, the dwell time.

Data range	Unit
1 to 9999999	ms

When diameter programming is specified with bit 3 (DIAx) of parameter No. 1006, bit 1 (CDI) of parameter No. 8005 can be used to specify whether a radius or diameter is to be used in a command.

NOTE

When the increment system IS-C is used, the least input increment for the dwell time can be set to 0.1 ms, according to the setting of bit 1 (DWE) of parameter No. 8002.

- (6) Continuous feed (EC0g to EC6g: 06h)

For this command, signal EID31g is used to specify the direction of continuous feed, as follows:

- 0: Positive direction
- 1: Negative direction

Signals EID0g to EID30g are undefined.

- (7) Auxiliary functions (EC0g to EC6g: 12h)
 Auxiliary functions 2 (EC0g to EC6g: 14h)
 Auxiliary functions 3 (EC0g to EC6g: 15h)

For this command, the signals are used to specify, in binary format, an auxiliary function code to be sent to the PMC. The auxiliary function code can be specified using either one or two bytes, depending on the setting of bit 6 (AUX) of parameter No. 8001, in signals EID0g to EID15g.

- (8) Machine coordinate system selection (EC0g to EC6g: 20h)

For this command, the signals are used to specify, in binary format, an absolute machine coordinate, according to the increment system used by the axis.

Example: For absolute value “10000”

Input increment	inch	1.0000	mm	10.000
Output increment	mm	25.400	inch	0.3937

The direction of rotation can be specified about a rotation axis with a parameter. To enable the roll-over function, set bit 0 (ROAx) of parameter No. 1008 to 1. Then, select whether the tool is to be rotated in the direction corresponding to the sign of the specified value, or in whichever direction minimizes the distance to the end point, using bit 1 (RABx) of parameter No. 1008. The moving distance per rotation must be set in parameter No. 1260.

- (9) When a torque control command (EC0g to EC6g: 11h) is specified
 Specify the torque data.

Specify a positive value when the torque is to be applied in the positive direction. Specify a negative value when the torque is to be applied in the negative direction.

The specified torque data can be changed in torque control mode by setting the new data in the signal then inverting the logic of axis control command read signal EBUFG.

Valid data range	Units
-99999999 to +99999999	0.00001 Nm

NOTE

The data units will be 0.001 N when a linear motor is being used.

5 Axis control command read signal EBUFG

[Classification] Input signal

[Function] Directs the CNC to read a block of command data for PMC axis control. See “Basic procedure” for details of the operation performed when this signal is set from “0” to “1” or from “1” to “0”.

6 Axis control command read completion signal EBSYg

[Classification] Output signal

[Function] Notifies the system that the CNC has read a block of command data for PMC axis control and has stored the block in the input buffer. See “Basic procedure” for details of the output conditions and the procedure.

7 Reset signal ECLRg

[Classification] Input signal

[Function] Resets the corresponding PMC-controlled axis.

When this signal is set to “1”, the following is performed:

- (1) When the tool is moving along the axis: Decelerates and stops the tool.
- (2) When the tool is dwelling: Stops the operation.
- (3) When an auxiliary function is being executed: Stops the operation.

Simultaneously, all buffered commands are canceled. Any control command is ignored while this signal is set to “1”.

The continuous feed command (EC0g to EC6g: 06h) and external pulse synchronization command (EC0g to EC6g: 0Bh, 0Dh to 0Fh) can be terminated by setting reset signal ECLRg to “1”. When these commands are terminated, the servo motor decelerates and stops, the axis moving signal EGENg is set to “0”, and the control axis selection status signal *EAXSL is set to “0”. Confirm that the control axis selection status signal *EAXSL has been set to “0” before issuing the next command. Do not set reset signal ECLRg to “0” until the control axis selection status signal *EAXSL has been set to “0”.

The speed command (EC0g to EC6g: 10h) can also be terminated by setting the reset signal ECLRg to “1”. When this command is terminated, the servo motor decelerates and stops, and the axis moving signal EGENg is set to “0”. Confirm that the axis moving signal EGENg has been set to “0” before issuing the next command. Do not attempt to set the reset signal ECLRg to “0” until the axis moving signal EGENg has been set to “0”.

8 Axis control temporary stop signal ESTPg

[Classification] Input signal

[Function] When this signal is set to “1”, the following is performed:

- (1) When the tool is moving along the axis: Decelerates and stops the tool.

- (2) When the tool is in dwell: Stops the operation.
- (3) When an auxiliary function is being executed: Stops the operation when auxiliary function completion signal EFING is input.

The stopped operation can be restarted by setting this signal to “0”.

9 Block stop signal ESBKg
10 Block stop disable signal EMSBKg

[Classification] Input signal

[Function] When block stop signal ESBKg is set to “1” during the execution of a command issued from the PMC, axis control is stopped after the block being executed is completed. When this signal is set to “0”, the buffered command is executed. Block stop signal ESBKg is disabled when block stop disable signal EMSBKg is set to “1” for the block.

The timing chart for the command operation is shown below.

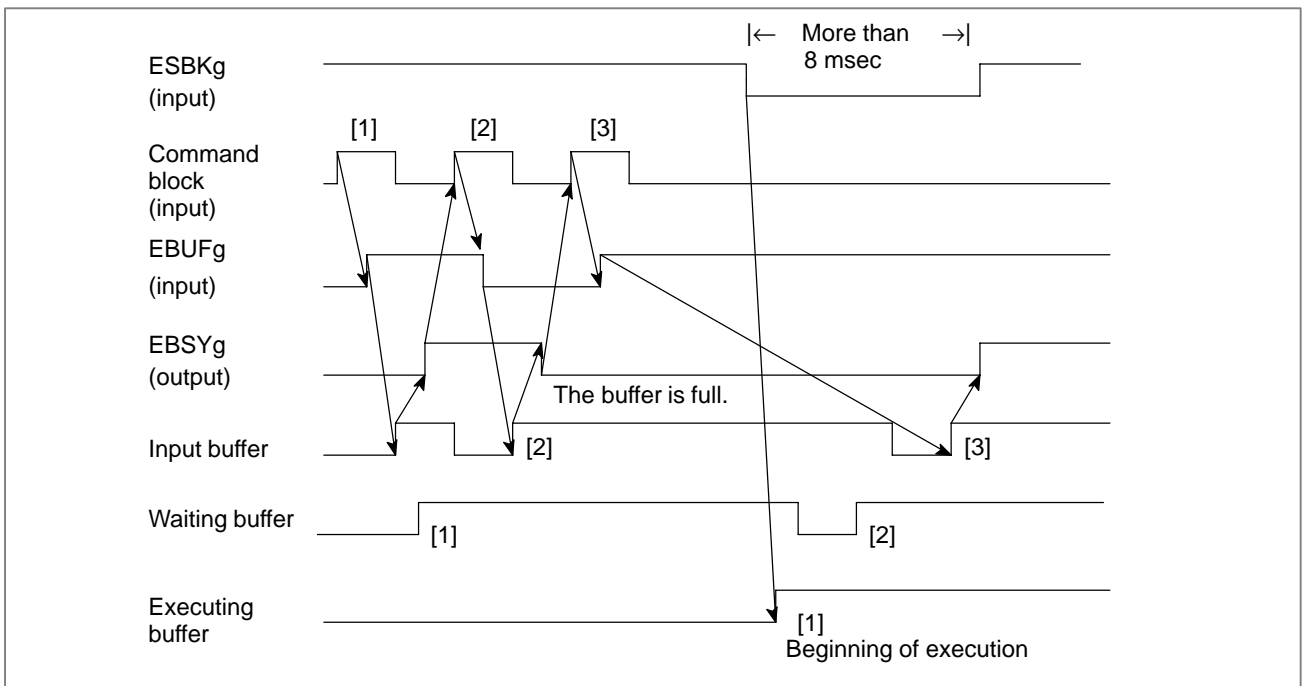

11 Auxiliary function code signals EM11g to EM48g

[Classification] Output signal

12 Auxiliary function strobe signal EMFg

[Classification] Output signal

13 Miscellaneous function 2 strobe signal EMF2g

[Classification] Output signal

14 Miscellaneous function 3 strobe signal EMF3g

[Classification] Output signal

15 Auxiliary function completion signal EFINg

[Classification] Input signal

[Function] When an auxiliary function command (EC0g to EC6g: 12h) is issued by the PMC, the auxiliary function code is specified in a byte (using signals EID0g to EID7g) or two bytes (using signals EID0g to EID15g), depending on the setting of bit 6 (AUX) of parameter No. 8001.

The CNC sends the auxiliary function code specified in signals EID0g to EID7g and EID8g to EID15g to auxiliary function code signals EM11g to EM28g and EM31g to EM48g and awaits the auxiliary function completion signal EFINg. When the auxiliary function completion signal EFINg is returned, the CNC starts executing the next block.

The timings for sending the auxiliary function code signals and auxiliary function strobe signal, as well as for receiving the auxiliary function completion signal, are the same as those for the miscellaneous functions (M functions) under the control of the CNC. See “Auxiliary function executing signal” for details.

16 Servo-off signal ESOFg

[Classification] Input signal

[Function] When this signal is set to “1”, the servo motor for the corresponding PMC-controlled axis is turned off (servo-off state).

When this signal is set to “0”, the servo motor is turned on.

When a torque control command (EC0g to EC6g: 11h) is specified, entering the servo-off state cancels torque control mode, but the torque control state remains set. In such a case, set reset signal ECLRg to “1”.

17 Buffering disable signal EMBUFg

[Classification] Input signal

[Function] When this signal is set to “1”, commands from the PMC are not read while the executing, waiting, or input buffer contains a block. If this signal is set to “1” when any of these buffers contain a block, that block is executed but subsequent commands are read only when the buffers are all empty.

To discriminate the buffering disabled condition, the CNC outputs the axis control command read completion signal (EBSYg) only when a command is read when all buffers are empty.

The timing chart for the command operation is shown below.

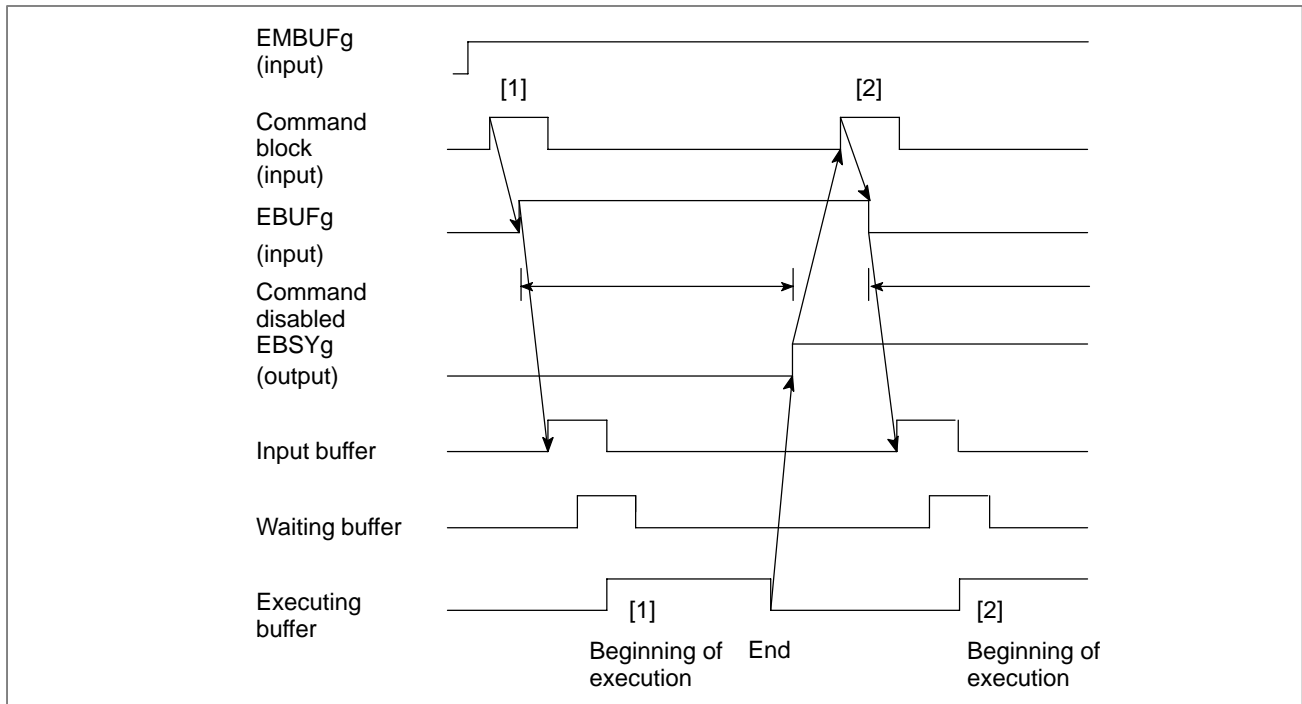

Buffering is disabled, regardless of the buffering disable signal EMBUFg, for the following commands:

- (1) Skip-feed per minute (EC0g to EC6g: 03h)
- (2) Reference position return (EC0g to EC6g: 05h)
- (3) 1st reference position return (EC0g to EC6g: 07h)
- (4) 2nd reference position return (EC0g to EC6g: 08h)
- (5) 3rd reference position return (EC0g to EC6g: 09h)
- (6) 4th reference position return (EC0g to EC6g: 0Ah)
- (7) Machine coordinate system selection (EC0g to EC6g: 20h)

The following commands, for which the reset signal ECLRg is used for termination, operate as though buffering had been disabled. That is, the subsequently specified block is not executed but canceled:

- (1) Continuous feed (EC0g to EC6g: 06h)
- (2) External pulse synchronization – main spindle (EC0g to EC6g: 0Bh)
- (3) External pulse synchronization – first manual handle (EC0g to EC6g: 0Dh)
- (4) External pulse synchronization – second manual handle (EC0g to EC6g: 0Eh)

- (5) External pulse synchronization – third manual handle
(EC0g to EC6g: 0Fh)
- (6) Speed command (EC0g to EC6g: 10h)

18 Control axis selection status signal *EAXSL

[Classification] Output signal

[Function] When this signal is set to “0”, control axis selection signals EAX1 to EAX8 can be changed.

This signal is set to “1” in the following cases:

- (1) When the tool is moving along a PMC-controlled axis
- (2) When a block is being read into a buffer
- (3) When the servo-off signal ESOFg is set to “1”

When this signal is set to “1”, control axis selection signals EAX1 to EAX8 cannot be changed. Any attempt to change these signals results in the output of P/S alarm No. 139.

If an attempt to change signals EAX1 to EAX8 is made when servo-off signal ESOFg is “1”, P/S alarm No. 139 occurs and cannot be released simply by setting reset signal ECLRg to “1”. In such a case, restore signals EAX1 to EAX8 or set servo-off signal ESOFg to “0” before setting reset signal ECLRg to “1”.

When a command is issued for any of the four paths with PMC axis control, signal *EAXSL is set to “1” to disable axis selection. Thus, changing signals EAX1 to EAX8 results in the output of P/S alarm No. 139. For paths for which commands are not issued, however, axis selection is enabled if bit 5 (DSL) of parameter No. 8004 is set accordingly.

19 In-position signal EINP_g

[Classification] Output signal

[Function] This signal is set to “1” when the corresponding PMC-controlled axis is in the in-position state.

When the tool is decelerated, in-position check is performed to disable the next command until the tool enters the in-position area. The in-position check, however, can be skipped using bit 6 (NCI) of parameter No. 8004 to reduce the cycle time.

NOTE

When the axis is fed at a very low speed, the in-position signal might turn to “1”.

20 Following zero checking signal ECKZg

[Classification] Output signal

[Function] This signal is set to “1” when following zero check or in-position check is being performed for the corresponding PMC-controlled axis.

21 Alarm signal EIALg

[Classification] Output signal

[Function] This signal is set to “1” when a servo alarm, overtravel alarm, or P/S alarm No. 130 or 139 occurs for the corresponding PMC-controlled axis. This signal is set to “0” when the reset signal ECLRg is set to “1” after the alarm is released, as described below.

- Servo alarm
Eliminate the cause of the alarm, then reset the CNC.
- Overtravel alarm
Move the tool into the area within the stored stroke limit, then reset the CNC.
The following commands can be used to move the tool into the area within the stored stroke limit during an overtravel alarm:
 - (1) Rapid traverse (EC0g to EC6g: 00h)
 - (2) Cutting feed-feed per minute (EC0g to EC6g: 01h)
 - (3) Cutting feed-feed per rotation (EC0g to EC6g: 02h)
 - (4) Continuous feed (EC0g to EC6g: 06h)
 - (5) External pulse synchronization – first manual handle (EC0g to EC6g: 0Dh)
 - (6) External pulse synchronization – second manual handle (EC0g to EC6g: 0Eh)
 - (7) External pulse synchronization – third manual handle (EC0g to EC6g: 0Fh)
- P/S alarm (130 or 139)
Reset the CNC. See “Alarms and messages” for details.

Reset signal ECLRg cannot be used to reset the CNC in the above cases. Use the reset button on the setting panel, external reset signal ERS, or emergency stop signal *ESP.

22 Axis moving signal EGENg

[Classification] Output signal

[Function] This signal is set to “1” when the tool is moving along the corresponding PMC-controlled axis according to commands such as rapid traverse (EC0g to EC6g: 00h) and cutting feed (EC0g to EC6g: 01h).

NOTE

This signal is set to “0” when distribution for the axis is completed (the signal is set to “0” during deceleration).

23 Auxiliary function executing signal EDENg

[Classification] Output signal

[Function] When an auxiliary function (EC0g to EC6g: 12h) is specified by the PMC, this signal is set to “1” during the period from when auxiliary function codes EID0g to EID15g are sent to auxiliary function code signals EM11g to EM48g until the auxiliary function completion signal EFINg is returned.

The timing chart for the command operation is shown below.

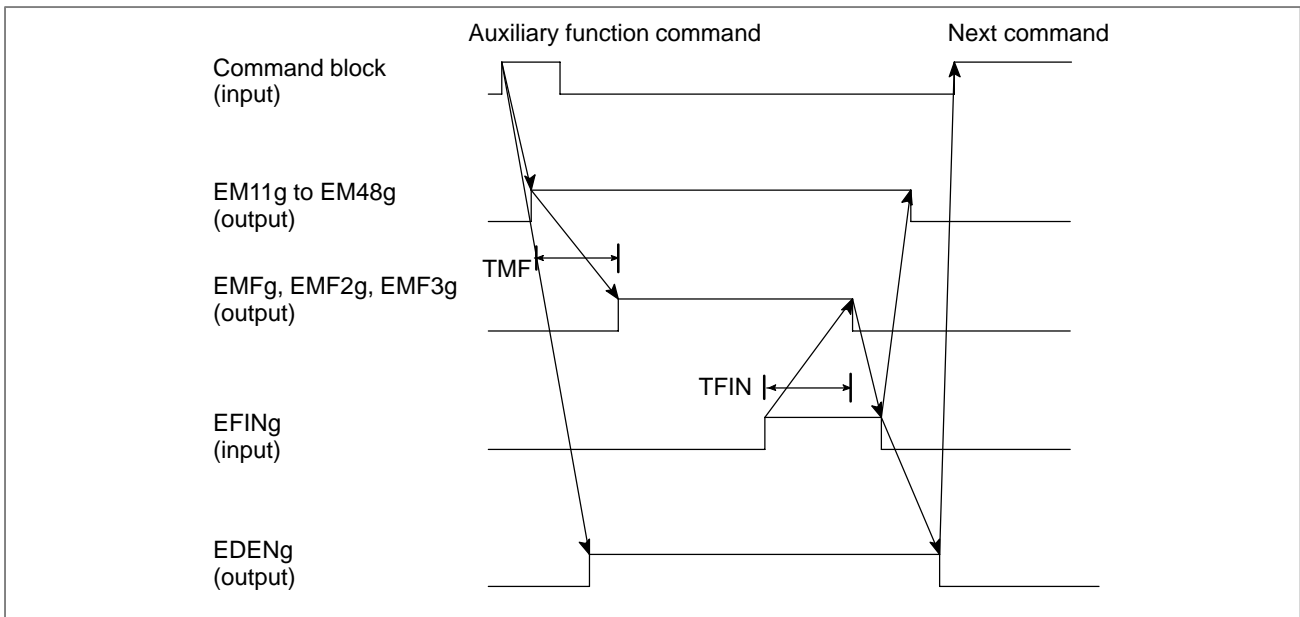

TMF and TFIN are set with parameters No. 3010 and 3011.

24 Negative-direction overtravel signal EOTNg

25 Positive-direction overtravel signal EOTPg

[Classification] Output signal

[Function] These signals are set to “1” when an overtravel alarm is detected. When the stroke limit in the negative direction is exceeded, signal EOTNg is set to “1”. When the stroke limit in the positive direction is exceeded, signal EOTPg is set to “1”. Simultaneously, alarm signal EIALg is set to “1”.

These signals are set to “0” when the overtravel alarm is released and reset signal ECLRg is set to “1”. See “Alarm signal EIALg” for details of how to release an overtravel alarm.

26 Feedrate override signals *FV0E to *FV7E

[Classification] Input signal

[Function] Like the CNC’s feedrate override signals *FV0 to *FV7, these signals can be used to select the override for the cutting feedrate, in steps of 1% from 0 to 254%, independently of the CNC using bit 2 (OVE) of parameter No. 8001.

These signals form an eight-bit binary code and correspond to the override value as follows:

$$\text{Override value} = \sum_{i=0}^7 |2^i \times Vi|\%$$

$V_i = 0$ when signal *FViE is 1

$V_i = 1$ when signal *FViE is 0

That is, each signal has the following significance:

*FV7E = 128%, *FV3E = 8% ,

*FV6E = 64%, *FV2E = 4% ,

*FV5E = 32%, *FV1E = 2% ,

*FV4E = 16%, *FV0E = 1%

When all signals are set to “0”, the override is regarded as being 0%, as well as when all signals are “1”.

27 Override cancellation signal OVCE

[Classification] Input signal

[Function] When override is enabled, independently of the CNC, by setting bit 2 (OVE) of parameter No. 8001, setting this signal to “1” fixes the cutting feed override to 100%. This signal does not affect the rapid traverse override.

28 Rapid traverse override signals ROV1E and ROV2E

[Classification] Input signal

[Function] These signals can be used to select the override for the rapid traverse rate, independently of the CNC, by setting bit 2 (OVE) of parameter No. 8001.

Rapid traverse override signals		Override value
ROV2E	ROV1E	
0	0	100%
0	1	50%
1	0	25%
1	1	F0

F0 is the minimum feedrate specified with parameter No. 1421.

29 Dry run signal DRNE 30 Manual rapid traverse selection signal RTE

[Classification] Input signal

[Function] These signals can be used to perform dry run or manual rapid traverse, independently of the CNC, by setting bit 2 (OVE) of parameter No. 8001. When the dry run signal DRNE is set to “1”, the specified rapid traverse rate and cutting feedrate are ignored and the tool moves at the dry run speed (set in parameter No. 1410) multiplied by the specified override. Bit 3 (RDE) of parameter No. 8001 can be used to specify whether to enable or disable dry run for rapid traverse.

When the manual rapid traverse selection signal RTE is set to “1” during dry run, the tool moves at the rapid traverse rate for rapid traverse and at the maximum jog feedrate for cutting feed. When the signal is set to “0”, the tool moves at the jog feedrate. When the dry run signal DRNE is set to “0”, the specified rapid traverse rate or cutting feedrate is restored.

Feedrate of Dry run

Manual rapid traverse select signal	Command from PMC	
	Rapid traverse	Feed
1	Rapid traverse rate	Maximum cutting feedrate
0	Dry run feed rate × JV(*)	Dry run feed rate × JV

* Can also be set to the rapid traverse rate with bit 3 (RDE) of parameter No. 8001.

31 Override 0% signal EOV0

[Classification] Output signal

[Function] This signal is set to “1” when the feedrate override is 0%.

32 Skip signal ESKIP

[Classification] Input signal

[Function] When this signal is set to “1” during execution of the skip cutting command, the block being executed is immediately stopped and the next block is executed. Bit 7 (SKE) of parameter No. 8001 can be used to select whether to use signal SKIP, which is the common skip signal for the PMC and CNC, or PMC-specific skip signal ESKIP.

NOTE

When two paths are controlled, the skip signal ESKIP is valid for the first path. For the second path, use the SKIP signal (X013, #7), which is also used by the CNC.

33 Distribution completion signals EADEN1 to EADEN8

[Classification] Output signal

[Function] These signals are set to “0” when the tool is moving with a command from the PMC. The signals are set to “1” when the tool is not moving, except when it is stopped by an axis control temporary stop signal ESTPg during the execution of a move command.

34 Buffer full signal EABUFg

[Classification] Output signal

[Function] This signal is set to “1” when the input buffer contains a command block.

35 Controlling signals EACNT1 to EACNT8

[Classification] Output signal

[Function] When the control axis selection status signal *EAXSL is set to “1”, signal EACNTn corresponding to the axis being controlled is set to “1”.

36 External deceleration signals

*+ED1 to *+ED8,
*-ED1 to *-ED8

[Classification] Input signal

[Function] These signals are also used by the CNC. The signals are provided for each direction of the individual controlled axes. The plus or minus sign in the signal name indicates the direction, and the number at the end corresponds to the axis number of the controlled axis.

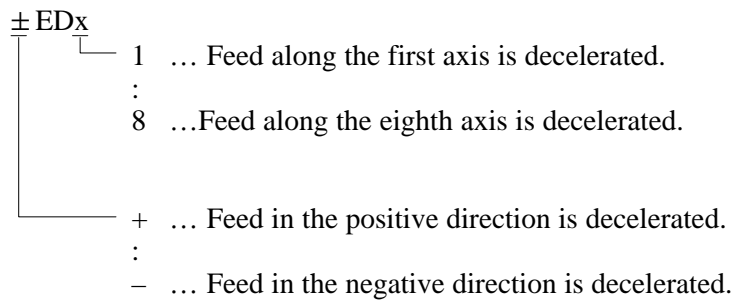

When any of the following axis control command is specified while the EDC bit (bit 0 of parameter 8005) is held at 1, the external deceleration function becomes effective:

- | | |
|---|---------------------|
| (1) Rapid traverse | (EC0g to EC6g: 00h) |
| (2) Cutting feed per minute | (EC0g to EC6g: 01h) |
| (3) Reference position return | (EC0g to EC6g: 05h) |
| (4) Continuous feed | (EC0g to EC6g: 06h) |
| (5) First reference position return | (EC0g to EC6g: 07h) |
| (6) Second reference position return | (EC0g to EC6g: 08h) |
| (7) Third reference position return | (EC0g to EC6g: 09h) |
| (8) Fourth reference position return | (EC0g to EC6g: 0Ah) |
| (9) Machine coordinate system selection | (EC0g to EC6g: 20h) |

While the signal is held at “0”, the feedrate in the corresponding direction of axial movement can be reduced to the speed specified in parameter 1427 (external deceleration speed).

When the feedrate is lower than the external deceleration speed, the specified feedrate is valid.

The feedrate on other axes for which the signal is not held at “0” is not affected.

37 Accumulated zero check signal ELCKZg

[Classification] Input signal

[Function] Setting this signal to 1 causes an accumulated zero check between blocks to be made at a subsequent cutting feed command.

(1) Cutting feed per minute (EC0g to EC6g: 01h)

(2) Cutting feed per rotation (EC0g to EC6g: 02h)

This enables the chopping function.

38 Torque control mode signal TRQMx

[Classification] Output signal

[Function] This signal indicates which axis is placed in torque control mode under PMC axis control.

Signal address

MT→CNC

ADDRESS

	#7	#6	#5	#4	#3	#2	#1	#0
X004	SKIP	ESKIP						

PMC→CNC

ADDRESS

	#7	#6	#5	#4	#3	#2	#1	#0
G118	*+ED8	*+ED7	*+ED6	*+ED5	*+ED4	*+ED3	*+ED2	*+ED1
G120	*-ED8	*-ED7	*-ED6	*-ED5	*-ED4	*-ED3	*-ED2	*-ED1
G136	EAX8	EAX7	EAX6	EAX5	EAX4	EAX3	EAX2	EAX1
G150	DRNE	RTE	OVCE				ROV2E	ROV1E
G151	*FV7E	*FV6E	*FV5E	*FV4E	*FV3E	*FV2E	*FV1E	*FV0E

For group A

	#7	#6	#5	#4	#3	#2	#1	#0
G142	EBUFA	ECLRA	ESTPA	ESOFA	ESBKA	EMBUFA	ELCKZA	EFINA
G143	EMSBKA	EC6A	EC5A	EC4A	EC3A	EC2A	EC1A	EC0A
G144	EIF7A	EIF6A	EIF5A	EIF4A	EIF3A	EIF2A	EIF1A	EIF0A
G145	EIF15A	EIF14A	EIF13A	EIF12A	EIF11A	EIF10A	EIF9A	EIF8A
G146	EID7A	EID6A	EID5A	EID4A	EID3A	EID2A	EID1A	EID0A
G147	EID15A	EID14A	EID13A	EID12A	EID11A	EID10A	EID9A	EID8A
G148	EID23A	EID22A	EID21A	EID20A	EID19A	EID18A	EID17A	EID16A
G149	EID31A	EID30A	EID29A	EID28A	EID27A	EID26A	EID25A	EID24A

For group B

	#7	#6	#5	#4	#3	#2	#1	#0
G154	EBUFB	ECLRB	ESTPB	ESOFB	ESBKB	EMBUFB	ELCKZB	EFINB
G155	EMSBKB	EC6B	EC5B	EC4B	EC3B	EC2B	EC1B	EC0B
G156	EIF7B	EIF6B	EIF5B	EIF4B	EIF3B	EIF2B	EIF1B	EIF0B
G157	EIF15B	EIF14B	EIF13B	EIF12B	EIF11B	EIF10B	EIF9B	EIF8B
G158	EID7B	EID6B	EID5B	EID4B	EID3B	EID2B	EID1B	EID0B
G159	EID15B	EID14B	EID13B	EID12B	EID11B	EID10B	EID9B	EID8B
G160	EID23B	EID22B	EID21B	EID20B	EID19B	EID18B	EID17B	EID16B
G161	EID31B	EID30B	EID29B	EID28B	EID27B	EID26B	EID25B	EID24B

For group C

	#7	#6	#5	#4	#3	#2	#1	#0
G166	EBUFC	ECLRC	ESTPC	ESOFC	ESBKC	EMBUFC	ELCKZC	EFINC
G167	EMSBKC	EC6C	EC5C	EC4C	EC3C	EC2C	EC1C	EC0C
G168	EIF7C	EIF6C	EIF5C	EIF4C	EIF3C	EIF2C	EIF1C	EIF0C
G169	EIF15C	EIF14C	EIF13C	EIF12C	EIF11C	EIF10C	EIF9C	EIF8C
G170	EID7C	EID6C	EID5C	EID4C	EID3C	EID2C	EID1C	EID0C
G171	EID15C	EID14C	EID13C	EID12C	EID11C	EID10C	EID9C	EID8C
G172	EID23C	EID22C	EID21C	EID20C	EID19C	EID18C	EID17C	EID16C
G173	EID31C	EID30C	EID29C	EID28C	EID27C	EID26C	EID25C	EID24C

For group D

	#7	#6	#5	#4	#3	#2	#1	#0
G178	EBUFD	ECLRD	ESTPD	ESOFD	ESBKD	EMBUFD	ELCKZD	EFIND
G179	EMSBKD	EC6D	EC5D	EC4D	EC3D	EC2D	EC1D	EC0D
G180	EIF7D	EIF6D	EIF5D	EIF4D	EIF3D	EIF2D	EIF1D	EIF0D
G181	EIF15D	EIF14D	EIF13D	EIF12D	EIF11D	EIF10D	EIF9D	EIF8D
G182	EID7D	EID6D	EID5D	EID4D	EID3D	EID2D	EID1D	EID0D
G183	EID15D	EID14D	EID13D	EID12D	EID11D	EID10D	EID9D	EID8D
G184	EID23D	EID22D	EID21D	EID20D	EID19D	EID18D	EID17D	EID16D
G185	EID31D	EID30D	EID29D	EID28D	EID27D	EID26D	EID25D	EID24D

CNC→PMC		ADDRESS							
		#7	#6	#5	#4	#3	#2	#1	#0
	F112	EADEN8	EADEN7	EADEN6	EADEN5	EADEN4	EADEN3	EADEN2	EADEN1
	F129	*EAXSL		EOV0					
For group A	F130	EBSYA	EOTNA	EOTPA	EGENA	EDENA	EIALA	ECKZA	EINPA
	F131					EMF3A	EMF2A	EABUFA	EMFA
	F132	EM28A	EM24A	EM22A	EM21A	EM18A	EM14A	EM12A	EM11A
For group B	F133	EBSYB	EOTNB	EOTPB	EGENB	EDENB	EIALB	ECKZB	EINPB
	F134					EMF3B	EMF2B	EABUFB	EMFB
	F135	EM28B	EM24B	EM22B	EM21B	EM18B	EM14B	EM12B	EM11B
For group C	F136	EBSYC	EOTNC	EOTPC	EGENC	EDENC	EIALC	ECKZC	EINPC
	F137					EMF3C	EMF2C	EABUFC	EMFC
	F138	EM28C	EM24C	EM22C	EM21C	EM18C	EM14C	EM12C	EM11C
For group D	F139	EBSYD	EOTND	EOTPD	EGEND	EDEND	EIALD	ECKZD	EINPD
	F140					EMF3D	EMF2D	EABUFD	EMFD
	F141	EM28D	EM24D	EM22D	EM21D	EM18D	EM14D	EM12D	EM11D
Group A	F142	EM48A	EM44A	EM42A	EM41A	EM38A	EM34A	EM32A	EM31A
Group B	F145	EM48B	EM44B	EM42B	EM41B	EM38B	EM34B	EM32B	EM31B
Group C	F148	EM48C	EM44C	EM42C	EM41C	EM38C	EM34C	EM32C	EM31C
Group D	F151	EM48D	EM44D	EM42D	EM41D	EM38D	EM34D	EM32D	EM31D

	#7	#6	#5	#4	#3	#2	#1	#0
F182	EACNT8	EACNT7	EACNT6	EACNT5	EACNT4	EACNT3	EACNT2	EACNT1
F190	TRQM8	TRQM7	TRQM6	TRQM5	TRQM4	TRQM3	TRQM2	TRQM1

Parameter

1427	External deceleration speed of each axis
------	--

[Data type] Word axis

[Unit of data]	Increment system	Unit of data	Valid data range	
			IS-B	IS-C
[Valid data range]	Millimeter machine	1 mm/min	6 to 15000	6 to 12000
	Inch machine	0.1 inch/min	6 to 6000	6 to 4800
	Rotation axis	1 deg/min	6 to 15000	6 to 12000

	#7	#6	#5	#4	#3	#2	#1	#0
1803				TQF				

[Data type] Bit

TQF In torque control mode,
 0 : Follow-up is not performed.
 1 : Follow-up is performed.

1885	Permissible value of integrated travel distance under torque control
------	--

[Data type] Word axis

[Unit of data] Detection unit

[Valid data range] 0 to 32767

This parameter sets the maximum permissible value for the integrated travel distance in torque control mode. If the integrated travel distance exceeds the value set in this parameter, servo alarm No. 423 is issued.

NOTE
 This parameter is valid when TQF (bit 4 of parameter No. 1803) is set to 0.

1886	Torque control cancel limit
------	-----------------------------

[Data type] Word axis

[Unit of data] Detection unit

[Valid data range] 0 to 32767

This parameter sets the cancel limit value used to cancel torque control mode.

When the position error falls below or is equal to the value set in this parameter, torque control mode is canceled and position control becomes effective.

NOTE

This parameter is valid when TQF (bit 4 of parameter 1803) is held 0.

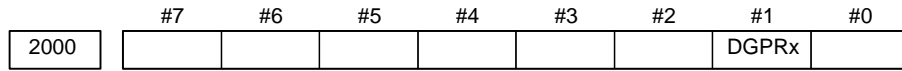

[Data type] Bit axis

DGPRx At power-ON, the torque constant (parameter No. 2105):
 0 : Is automatically set to the standard value specific to the motor.
 1 : Is not automatically set to the standard value specific to the motor.

NOTE

This parameter is intended to initialize the servo parameters. It causes parameters other than those for torque constants to be set automatically. Be careful when using this parameter.

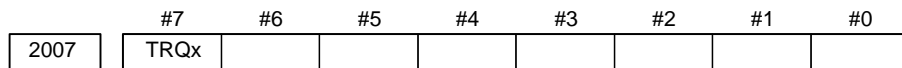

[Data type] Bit axis

TRQx Torque control:
 0 : Is not performed for the axis.
 1 : Is performed for the axis.

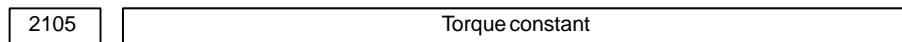

[Data type] Word axis

[Unit of data] 0.00001 Nm/(torque command)

[Valid data range] 1 to 32767

A torque constant is set for each motor torque characteristic.

NOTE

When a linear motor is used, the units of data are 0.001 N/(torque command).

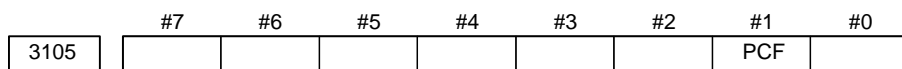

[Data type] Bit

PCF Movement along PMC-controlled axes is included in the actual speed display
 0 : Is included
 1 : Is not included

NOTE

This parameter is valid when the same axis is controlled alternately by the CNC and PMC.

	#7	#6	#5	#4	#3	#2	#1	#0
3709	THB							

[Data type] Bit

THB The start type for threading is:

0 : A type

1 : B type

CAUTION

When PMC axis control is used, set this parameter to 1.

	#7	#6	#5	#4	#3	#2	#1	#0
8001	SKE	AUX	NCC		RDE	OVE		MLE

[Data type] Bit

MLE Machine lock signal MLK is valid for PMC-controlled axes

0 : Is valid

1 : Is invalid

NOTE

Each-axis machine lock signals MLK1 to MLK8 are always valid, regardless of the setting of this parameter.

OVE Signals related to dry run and override used in PMC axis control

0: Same signals as those used for the CNC

(1) Feedrate override signals *FV0 to *FV7

(2) Override cancellation signal OVC

(3) Rapid traverse override signals ROV1 and ROV2

(4) Dry run signal DRN

(5) Rapid traverse selection signal RT

1: Signals specific to the PMC

(1) Feedrate override signals *FV0E to *FV7E

(2) Override cancellation signal OVCE

(3) Rapid traverse override signals ROV1E and ROV2E

(4) Dry run signal DRNE

(5) Rapid traverse selection signal RTE

RDE Dry run is valid for rapid traverse in PMC axis control

0 : Is invalid

1 : Is valid

- NCC** When a travel command is issued for a PMC-controlled axis (selected by a controlled-axis selection signal) according to the program:
 0 : P/S alarm 139 is issued while the PMC controls the axis with an axis control command. While the PMC does not control the axis, a CNC command is enabled.
 1 : P/S alarm 139 is issued unconditionally.
- AUX** The number of bytes for the code of an auxiliary function (12H) command to be output is
 0 : 1 byte type (0 to 255)
 1 : 2 bytes type (0 to 65535)
- SKE** Skip signal during axis control by the PMC
 0 : Uses the same signal SKIP (X004#7) as CNC.
 1 : Uses dedicated axis control signal ESKIP (X004#6) used by the PMC.

NOTE
 If SKE is set to 1 when 2-path control is being applied, it is effective only for path 1. Path 2 uses the same signal (SKIP <X013#7>) as that for the CNC.

	#7	#6	#5	#4	#3	#2	#1	#0
8002	FR2	FR1	PF2	PF1	F10	SUE	DWE	RPD

[Data type] Bit

- RPD** Rapid traverse rate for PMC-controlled axes
 0 : Feedrate specified with parameter No. 1420
 1 : Feedrate specified with the feedrate data in an axis control command
- DWE** Minimum time which can be specified in a dwell command in PMC axis control when the increment system is IS-C
 0 : 1 ms
 1 : 0.1 ms
- SUE** Whether acceleration/deceleration is performed for an axis that is synchronized with external pulses, for external pulse synchronization commands in PMC axis control
 0 : Is performed (exponential acceleration/deceleration)
 1 : Is not performed
- F10** Least increment for the feedrate for cutting feed (per minute) in PMC axis control

F10	Metric input	Inch input
0	1 mm/min	0.01 inch/min
1	10 mm/min	0.1 inch/min

PF1, PF2 Set the the feedrate unit of feed per minute in PMC axis control

PF2	PF1	Feedrate unit
0	0	1/1
0	1	1/10
1	0	1/100
1	1	1/1000

FR1, FR2 Set the feedrate unit for feed per rotation for an axis controlled by the PMC.

FR2	FR1	Metric input	Inch input
0	0	0.0001 mm/rev	0.000001 inch/rev
1	1		
0	1	0.001 mm/rev	0.00001 inch/rev
1	0	0.01 mm/rev	0.0001 inch/rev

	#7	#6	#5	#4	#3	#2	#1	#0
8003								PIM

NOTE

When this parameter is set, the power must be turned off then back on again to make the setting effective.

[Data type] Bit type

PIM If a linear axis is controlled solely by the PMC, the commands for that axis are:

0 : Affected by inch/metric input.

1 : Not affected by inch/metric input.

	#7	#6	#5	#4	#3	#2	#1	#0
8004	NDI	NCI	DSL	G8R	G8C	JFM	NMT	CMV
		NCI	DSL	G8R	G8C	JFM	NMT	CMV

[Data type] Bit type

CMV If the PMC issues a command for an axis after the completion of a movement along that axis according to a command issued by the CNC, but before receiving the signal indicating that the miscellaneous function is completed in the same block,

0 : P/S alarm No. 130 occurs.

1 : The axis is handled as a PMC axis and the specified movement is executed.

NMT If the CNC issues a command that does not result in any movement along a PMC-controlled axis while another command, specified for the axis, is being processed,

0 : P/S alarm No. 130 occurs.

1 : No alarm occurs.

JFM Specifies the units used to specify the feedrate for continuous feed (06H) for a PMC-controlled axis.

Increment system	JFM	Metric input	Inch input	Rotation axis
IS-B	0	1 mm/min	0.01 inch/min	0.00023 min ⁻¹
	1	200 mm/min	2.00 inch/min	0.046 min ⁻¹
IS-C	0	0.1 mm/min	0.001 inch/min	0.000023 min ⁻¹
	1	20 mm/min	0.200 inch/min	0.0046 min ⁻¹

G8C If a cutting feed command is specified for a PMC-controlled axis, advanced preview control is:

0 : Disabled.

1 : Enabled.

NOTE

The above setting is effective only when the NAHx bit (bit 7 of parameter No. 1819) is set to 0.

G8R If a rapid traverse command is specified for a PMC-controlled axis, advanced preview control is:

0 : Disabled.

1 : Enabled.

NOTE

The above setting is effective only when the NAHx bit (bit 7 of parameter No. 1819) is set to 0.

DSL If an axis exchange is attempted while the selection of a PMC-controlled axis is inhibited,

0 : The attempt fails and a P/S alarm No. 139 occurs.

1 : The axis exchange is executed for the axes that belong to an unspecified path.

NCI During deceleration along an axis controlled by the PMC, the in-position check is:

0 : Performed.

1 : Not performed.

NDI When diameter programming is selected for a PMC controlled axis, under PMC axis control:

0 : Radius programming is used to specify the travel distance and feedrate.

1 : Diameter programming is used to specify the travel distance and feedrate.

NOTE

While the CDI bit (bit 1 of parameter No. 8005) is held to 0, the NDI bit is valid for an axis of diameter programming (the DIAx bit (bit 3 of parameter No. 1006) is set to 1).

	#7	#6	#5	#4	#3	#2	#1	#0
8005	MFD						CDI	EDC

[Data type] Bit

EDC Under PMC axis control, the external deceleration signal is:
 0 : Ineffective.
 1 : Effective.

CDI When diameter programming is selected for a PMC controlled axis, under PMC axis control:
 0 : Radius programming is used to specify the travel distance and feedrate.
 1 : Diameter programming is used to specify the travel distance, and radius programming is used to specify the feedrate.

NOTE

- 1 This parameter is valid when the DIAx bit (bit 3 of parameter 1006) is held to 1.
- 2 When the CDI bit is set to 1, the NDI bit (bit 7 of parameter 8004) is invalid.

MFD : The miscellaneous function individual output of the PMC axis control function is:
 0 : Not effective.
 1 : Effective.

8010	Selection of the DI/DO group for each axis controlled by the PMC
------	--

[Data type] Byte axis

[Valid data range] 1 to 4

Specify the DI/DO group to be used to specify a command for each PMC-controlled axis.

Value	Description
1	DI/DO group A (G142 to G153) is used.
2	DI/DO group B (G154 to G165) is used.
3	DI/DO group C (G166 to G177) is used.
4	DI/DO group D (G178 to G189) is used.

NOTE

If another value is specified, the axis is not PMC-controlled.

8022 Maximum feedrate for feed per rotation along a PMC-controlled axis

[Data type] Word axis

[Unit of data]

[Valid data range]

Increment system	Unit of data	Valid data range	
		IS-A, IS-B	IS-C
Millimeter machine	1 mm/min	6 to 15000	6 to 12000
Inch machine	0.1 inch/min	6 to 6000	6 to 4800
Rotation axis	1 deg/min	6 to 15000	6 to 12000

Specify the maximum feedrate for feed per rotation along a PMC-controlled axis

NOTE

The maximum feedrate set to first axis is valid for all axes. The data after the second axis is invalid.

8028 Linear acceleration/deceleration time constant for jog feed specified by the speed command for each PMC-controlled axis

[Data type] Word axis

[Unit of data] msec/1000 min⁻¹

[Valid data range] 0 to 32767

Specify, for each PMC-controlled axis, the time needed to increase or decrease the speed of the servo motor by 1000 min⁻¹, that is, the time constant of linear acceleration/deceleration for jog feed according to the speed specified for that axis.

NOTE

If 0 is specified, the system does not control the acceleration/deceleration.

Alarm and message

A servo alarm or overtravel alarm for a PMC-controlled axis is detected in the same way as an alarm for a CNC-controlled axis.

If an alarm occurs, the alarm is handled by using the normal procedure, alarm signal EIALg is set to “1” to inform the PMC of the alarm.

(If an overtravel alarm occurs, either negative overtravel signal EOTNg or positive overtravel signal EOTPg is also set to “1”.)

If the PMC issues a command for a CNC-controlled axis, a P/S alarm No. 130 occurs.

Commands issued by the PMC are effective if the axis is in feed hold or single block stop mode. The command results in the issue of an alarm if cutting feed is executed with an override of 0%, or if interlock is enabled. If the CNC issues a command for a PMC-controlled axis, a P/S alarm No. 130 occurs.

If the PMC issues a movement command for an axis in the plane of polar coordinate interpolation in polar coordinate interpolation mode (G12.1), a P/S alarm No. 130 occurs.

(1) P/S Alarm

Number	Message	Description
130	ILLEGAL AXIS OPERATION	An axis control command was given by PMC to an axis controlled by CNC. Or an axis control command was given by CNC to an axis controlled by PMC. Modify the program.
139	CAN NOT CHANGE PMC CONTROL AXIS	A currently selected PMC controlled axis was selected again. Or, the CNC issued a control command for an axis that has been set as a PMC-controlled axis for which no command has been specified. Or, an axis under control of CNC was selected by the PMC.

(2) Servo alarm

Number	Message	Description
417	SERVO ALARM: n AXIS EXCESS ERR	An invalid parameter is specified for torque control. The torque constant parameter is set to 0.
422	SERVO ALARM: n AXIS EXCESS ERR	The maximum speed permitted under torque control has been exceeded.
423	SERVO ALARM: n AXIS EXCESS ERR	The maximum permissible value of integrated travel distance set in the parameter under torque control has been exceeded.

Warning**WARNING**

- 1 The mode selection, CNC reset, and other CNC statuses have no effect.
- 2 Feed hold, single block stop, reset, or interlock of one or all axes, performed by the CNC, does not affect a PMC-controlled axis. Similar control is possible by using the equivalent signals issued from the PMC.
- 3 The mirror image functions (setting, parameter, input signal) are disabled.

Caution**CAUTION**

- 1 Emergency stop or machine lock is enabled. Machine lock can be disabled if the MLE bit (bit 0 of parameter No. 8001) is set to "1". However, machine lock for an individual axis is always enabled.
- 2 In consecutive cutting feed blocks, a new block starts its operation without waiting for the following zero of the servo acceleration/deceleration. For all other cases, a new block starts its operation after the following zero of the servo acceleration/deceleration is confirmed.
- 3 Commands for a linear axis that is controlled solely by the PMC (not used as an axis controlled by the CNC) are not affected by inch/metric input setting of the PIM bit (bit 0 of parameter No. 8003). The current position display is also not affected by inch/metric input.
- 4 For a PMC-controlled axis, manual absolute mode is always set. If the PMC starts control of an axis after manual intervention (manual continuous feed, manual handle feed, etc.) is performed during automatic operation while manual absolute mode is not set (*ABSM is set to 1), manual absolute mode is set.
- 5 Under PMC axis control, all commands are handled as axis commands. Even for the miscellaneous functions, the position check is effective.
- 6 When the CNC executes the command to set the workpiece coordinate system setting (G54 to G59) during an axial movement by the PMC, a valid coordinate system cannot be set.
- 7 When threading is used, set bit 7 (THB) of parameter No. 3709 to 1.

Note**NOTE**

- 1 The actual speed excluding the effect of movement along a PMC-controlled axis can be displayed if the PCF bit (bit 1 of parameter No. 3105) is set to "1".
- 2 If an absolute pulse coder is used, a specified reference position is retained in memory, even after the power is turned off.
- 3 If the index table indexing function of the M series is used, the PMC cannot control the fourth axis.
- 4 The individual output of the miscellaneous function is provided by adding a signal for individual output. The timing diagram of controlling and specifying the miscellaneous function is not changed. The normal specifications of the miscellaneous functions for PMC axis control function are applied.

15.1.2 PMC Axis Control Expansion

Overview

This function makes it possible to use the following functions.

(1) Cutting fees (sec/block)

The time period until the end of the block can be specified.

(2) Simultaneous start mode on/off

If the simultaneous start mode is turned on, the commands for multiple paths can be simultaneously started.

(3) Superimposed command

A CNC axis command and PMC axis command can be superimposed.

This function is optional. To use this function, the PMC axis control function is needed.

(1) Cutting feed (sec/block)

- **Specification**
- **Axis control command signal**

Specify the time period until the end of the block in units of 0.1 s.

Command block		
Operation	Axis control command code signals EC0g to EC6g	Command block
Cutting feed (sec/block) (Exponential acceleration/deceleration or linear acceleration/deceleration before interpolation)	21H	Total movement value EID0g to EID31g Cutting feedrate EIF0g to EIF15g

- **Cutting feed rate signal (EIF0g to EIF15g)**

Specify the time period until the end of the block.

[Unit of data] 0.1s
[Valid data range] 1 to 32767

NOTE

- 1 If the feedrate is 0, buffering is performed, but the operation is not performed. The override function is disabled. If an override of 0% is specified, however, a stop is made. The dry run function is disabled.
- 2 If the simultaneous start mode is set on, linear interpolation can be performed by specifying identical values for the paths.

(2) Simultaneous start mode on/off

● **Specification**

If the simultaneous start mode is set on, the commands for multiple paths can be simultaneously started. By using this function together with sec/block described in Item (1), "Cutting feed," linear interpolation by PMC axis control can be implemented.

● **Axis control command signal**

Command block		
Operation	Axis control command code signals EC0g to EC6g	Command data
Simultaneous start mode off	40H	
Simultaneous start mode on	41H	Simultaneous start path specification EIF0g to EIF3g

● **Simultaneous start path specification (EIF0g to EIF3g)**

Specify the paths to be started simultaneously.

Set 1 in the bits corresponding to the command groups of the paths to be started simultaneously.

- EIF0g = GroupA
- EIF1g = GroupB
- EIF2g = GroupC
- EIF3g = GroupD

After the block of setting on the simultaneous start mode is executed, the command blocks of the paths to be started simultaneously are not executed until all the command blocks are set in the input buffer. This mode is valid until a command to set off the simultaneous start mode is specified.

● **Setting example**

Starting groups A and C simultaneously

Step 1: Set on the simultaneously start mode from Group C.

- EC0C to EC6C = 01000001(41H)
- EIF0C to EIF3C = 00000101(05H)

Step 2: Specify a cutting feed sec/block for Groups A and C.

- EC0A to EC6A = 00100001(21H)
- EC0C to EC6C = 00100001(21H)
- EIF0A to EIF7A = 00110010(32H)
- EIF0C to EIF7C = 00110010(32H)
- EIF8A to EIF15A = 00000000(00H)
- EIF8C to EIF15C = 00000000(00H)
- EID0A to EID7A = 01000000(40H)
- EID0C to EID7C = 01010000(50H)
- EID8A to EID15A = 00001101(0DH)
- EID8C to EID15C = 11000011(C3H)
- EID16A to EID23A = 00000011(03H)
- EID16C to EID23C = 00000000(00H)
- EID24A to EID31A = 00000000(00H)
- EID24C to EID31C = 00000000(00H)

The simultaneous start mode can be set on or off in any command group of any path. If a block for setting on the simultaneous start mode is specified while the simultaneous start mode is set on, the block becomes invalid. For the other paths, normal commands can be specified.

● Cautions

- (1) The following signals can be used for each path independently even in the simultaneous start mode: Reset signal ECLRg, buffering prohibition signal EMBUFg, servo off signal ESOFg, and miscellaneous function completed signal EFING.
- (2) If the axis control temporary stop signal ESTPg for any path in the simultaneous start mode is set to 1, the travel on controlled axes of all paths in the simultaneous start mode decelerates and stops.
- (3) If the block stop signal ESBKg for any path in the simultaneous start mode is set to 1, axis control stops when the blocks currently in progress end in all the paths in the simultaneous mode.
If the block stop prohibition signal EMSBKg is set to 1 in any path in the simultaneous start mode, the block stop signal ESBKg is invalid.
- (4) When setting on the simultaneous start mode, check that the buffer full signal EABUFg of the paths to be specified is 0.
- (5) If a path with no axis selected by the controlled axis selection signals EAX1 to EAX8 is selected in the simultaneous start mode, the simultaneous start operation does not start before the axis control command read signal EBUFg of the path is inverted.

(3) Superimposed command

● Specification

This command allows a program to give a command to an axis while travel on the axis is in progress under PMC axis control. For the axis on which the programmed operation is in progress, a command from PMC axis control can be given. This enables the PMC axis command and CNC axis command to be superimposed.

● Axis control superimposed command signal

	#7	#6	#5	#4	#3	#2	#1	#0
G200	EASIP8	EASIP7	EASIP6	EASIP5	EASIP4	EASIP3	EASIP2	EASIP1

[Classification] Input signal

[Function] Set 1 in the bit corresponding to the target axis of the superimposed command. The CNC axis command and PMC axis command can be superimposed.

The superimposed command is executed under the following conditions.

- CNC axis : Cutting feed command (incremental command)
- PMC axis : Cutting feed command

Otherwise, alarm 130 will be raised.

NOTE

- 1 Specify a cutting feed command by the automatic operation on the CNC side in the incremental mode.
- 2 If a signal is switched from 1 to 0 during superimposed operation, alarm 130 will be raised. When setting a signal to 0, do so after checking that the axial movement stops.
- 3 If the sum of the distribution amounts of the CNC and PMC is too large when a CNC axis command and axial movement by PMC axis control are superimposed, alarm 138 will be raised.

- **Commands that can be executed in succession during superimposed operation**

If any of the following commands is specified while a program is being executed, the command is executed before the superimposed command from the PMC ends.

- Block of no movement (miscellaneous function, dwell, sequence number, EOB, etc.)
- Cutting feed block
- Rapid traverse block which does not include the axis on which travel by the superimposed command of PMC axis control is in progress

- **Commands that cannot be executed in succession during superimposed operation**

If any of the following commands is specified while a program is being executed, the command is executed after the superimposed command from the PMC ends.

- Rapid traverse block which includes the axis on which travel by the superimposed command of PMC axis control is in progress
- Block of G05, G05.1, or G08

When any of the commands indicated above is specified, the block starts after the travel as on the PMC axis ends. Rapid traverse and cutting feed cannot be superimposed because many of their elements such as acceleration/deceleration type and feed forward state cannot be executed simultaneously. A block of G05, G05.1, or G08 cannot be executed in succession because the feed forward state changes.

Caution

(1) The state of advance feed forward under superimposed control depends on the state of the NC axis. Accordingly, G8C and G8R (bits 3 and 4 of parameter No.8004), which enable advanced preview control for the PMC axis, are invalid.

(2) If travel on the NC axis is not in progress (reset state, halt state, etc.), the feed forward state depends on the NC parameter settings.

If the superimposed command is executed in the reset state, for instance, FFD (bit 1 of parameter No.2005) determines whether the feed forward is enabled or disabled because the superimposed command of the PMC axis is for cutting feed.

If the superimposed command is started while the automatic operation is halted in the advanced preview control mode, the movement starts in the advanced preview control mode.

Parameter

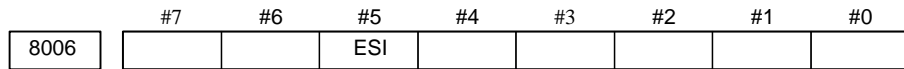

[Data type] Bit

ESI Superimposed control of the PMC axis control extension function is:
 0 : Extended.
 1 : Not extended.
 To use the superimposed command, set this parameter to 1.

Alarm and message

Number	Message	Description
130	ILLEGAL AXIS OPERATION	An axis control command was given by PMC to an axis controlled byCNC. Or an axis control command was given by CNC to an axis con-trolledby PMC. Modify the program.
138	SUPERIMPOSED DATA OVERFLOW	In PMC-based axis control, the increment for pulse distribution onthe CNC and PMC side are too large when the superimposed controextended function is used.

**15.1.3
 Constant Velocity
 Command Position
 Control**

Overview

This function enables control of the Cs-axis by executing a constant velocity command for PCM-axis control using position loop control. In other words, the function can operate the PMC-axis at a constant velocity by outputting command pulses equivalent to the rotational speed to the servo position control below, instead of outputting rotational speed data to the amplifier.

Block diagram

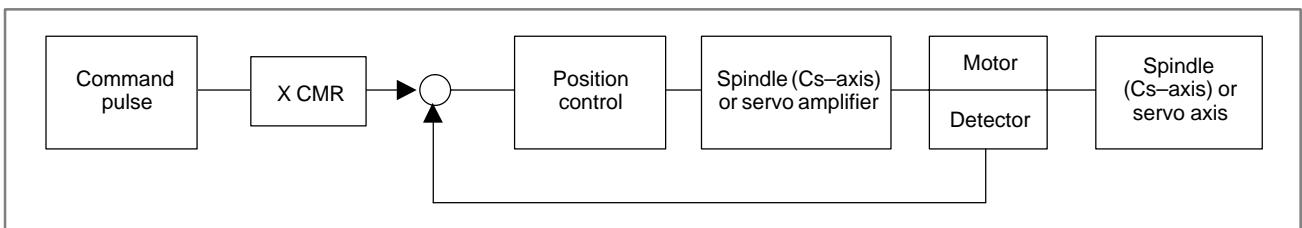

Specifications

Bit 4 of parameter No. 8005 specifies either position loop control or velocity loop control is used to execute a constant velocity command for PMC-axis control.

For a constant velocity command, acceleration or deceleration is performed only by its dedicated parameters and normal acceleration or deceleration is not performed even in position control (bit 4 of parameter No. 8005 is 1).

In position control (bit 4 of parameter No. 8005 is 1), an override is enabled.

Set the amount of travel per rotation, expressed in least command increments, in parameter No. 8040 for each axis and then use this to convert from a velocity command to a position command.

The following expression is obtained by assuming that P is output pulses (least command increment).

$$P = \frac{\text{Velocity command} \times \text{Parameter No. 8040} \times \text{ITP time} \times \text{Override}}{60 \times 1000 \times 100}$$

Notes

This function is included in the PMC-axis control function.

Parameter

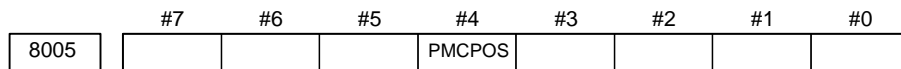

Parameter input

[Data type] Bit

PMCPOS A constant velocity command for PMC-axis control is performed as:
 0 : A velocity command.
 1 : A position command.

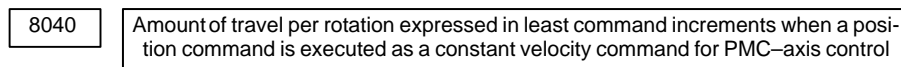

Parameter input

[Data type] 2 word axis

[Unit of data]

Setting unit	IS-B	IS-C
Millimeter machines	0.001	0.0001
Inch machines	0.0001	0.00001
Rotation axis	0.001	0.0001

[Valid data range] 1 to 999999999

When a constant velocity command for PMC-axis control is performed as a position command (bit 4 of parameter No. 8005 is 1), set the amount of travel per rotation expressed in least command increments.

15.2 EXTERNAL DATA INPUT

General

The following signals are used to send data from the PMC to the CNC.

Signal name	Signal code
Data signal for external data input (input)	ED0 to ED15
Address signal for external data input (input)	EA0 to EA6
Read signal for external data input (input)	ESTB
Read completion signal for external data input (output)	EREND
Search completion signal for external data input (output)	ESEND

The basic external data input procedure is described below:

- (1) The PMC sets the address signals, EA0 to EA6 that indicate the data type and data signals ED0 to ED15.
- (2) The PMC sets the read signal ESTB to "1".
- (3) When the ESTB signal is set to "1", the control unit reads the address.
- (4) After reading the address, the control unit sets the read completion signal EREND to "1".
- (5) When the EREND signal is set to "1", the PMC sets the ESTB signal, to 0.
- (6) When the ESTB signal is set to "0", the control unit sets the EREND signal to 0.

This completes the data input procedure. New data can now be entered.

The timing diagram is shown below:

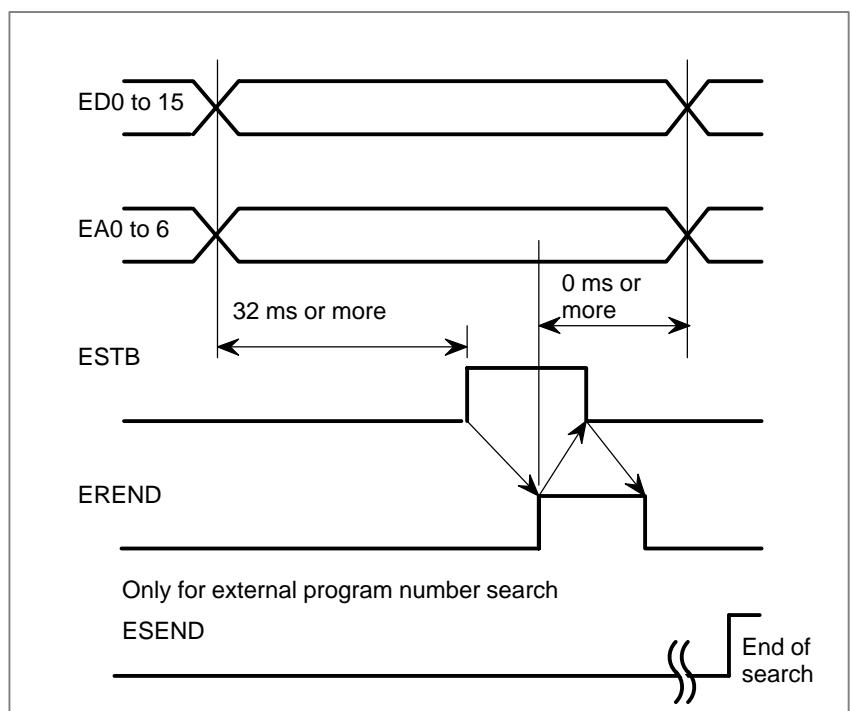

Data types accessed by external data input

No.	Item	E S E E E T A A A B 6 5 4	E E E E A A A A 3 2 1 0	ED15 to ED0			
				15141312	1110 9 8	7 6 5 4	3 2 1 0
1	External program number search	1 0 0 0	xxxx	Program number(BCD4 digits)			
				0 to 9	0 to 9	0 to 9	0 to 9
2	External tool compensation	1 0 0 1	xxxx	Offset value(BCD 4 digits with sign)			
				±0 to 7	0 to 9	0 to 9	0 to 9
3	External workpiece coordinate system shift	1 0 1 0	axis code	Shift value(BCD 4 digits with sign)			
				±0 to 7	0 to 9	0 to 9	0 to 9
4	External machine coordinate system shift	1 0 1 1	axis code	Machine coordinate system shift value(binary) ±0 to 9999			
5	Alarm set	1 1 0 0	0 0 0 0	Alarm No.(binary) 0 to 999			
	Alarm clear	1 1 0 0	0 0 0 1	Alarm No.(binary) 0 to 999			
	Oper to tor message list	1 1 0 0	0 1 0 0	Message No.(binary) 0 to 999			
	Operator message clear	1 1 0 0	0 1 0 1	Message No.(binary) 0 to 999			
	Message	1 1 0 0	0×1 1	character(Character code)			
6	Substitute No. of parts required	1 1 1 0	0 0 0 0	No. of parts required(BDC4 digits) 0 to 9 0 to 9 0 to 9 0 to 9			
	Substitute No. of parts machined	1 1 1 0	0 0 0 1	No. of parts machined(BDC4 digits) 0 to 9 0 to 9 0 to 9 0 to 9			

WARNING

Though bits EA4 to EA6 distinguish one set of data from another, the PMC must be interlocked in order to prevent data from other functions from being transmitted when another function is in progress.

NOTE

Input an axis code according to the list below.

Axis	EA3 to EA0			
	3	2	1	0
1st axis	0	0	0	0
2nd axis	0	0	0	1
3rd axis	0	0	1	0
4th axis	0	0	1	1
5th axis	0	1	0	0
6th axis	0	1	0	1
7th axis	0	1	1	0
8th axis	0	1	1	1

1) External Program Number Search

A program number (1 to 9999) is specified from an extended source and is selected in the CNC memory.

For machines that can load several kinds of workpieces, this function can automatically select the program to be executed corresponding to a specific workpiece.

Data for the external program number search is accepted regardless of CNC mode, but the search execution can be made only in the reset state in MEM mode.

The ESEND signal switches from “0” to “1” on completion of external program number search. This signal does not turn to “0” unless the cycle start or reset signal is input, or another search is made. Use ESEND to initiate a cycle start signal after the search.

Because a search operation is deferred until a reset occurs in the MEM mode, an external program number search attempted during a CNC operation (OP = 1) results in the program being started immediately after the end of an automatic operation in a sequence in which the automatic operation is started by checking only the ESEND signal (search completion signal for external data input). For this reason, using the ESC parameter (bit 3 of parameter No. 6300) enables an external program number search to be canceled at a CNC reset. Concretely, if a reset signal is input between the time the ESTB signal (read signal for external data input) is input and the time a search would be executed, setting the ESC parameter (bit 3 of parameter No. 6300) to 1 keeps the search from being executed. At the same time, the controller uses the ESCAN (search cancel signal for external data input) signal to inform the PMC that the search has been canceled. The ESEND signal (search completion signal for external data input) will not become 1, because the search is canceled.

The controller checks the state of the RST (NC reset) signal for a reset input between the rising edge of the ESTB signal (read signal for external data input) and the start of the search. Concretely, the controller cancels the external program number search if the RST (NC reset) signal becomes 1 even momentarily in this period. The ESCAN signal (search cancel signal for external data input) becomes high at the beginning of the search. However, it becomes low when the next search is executed (for example, when a cycle start or reset signal is input), similarly to the ESEND signal (search completion signal for external data input).

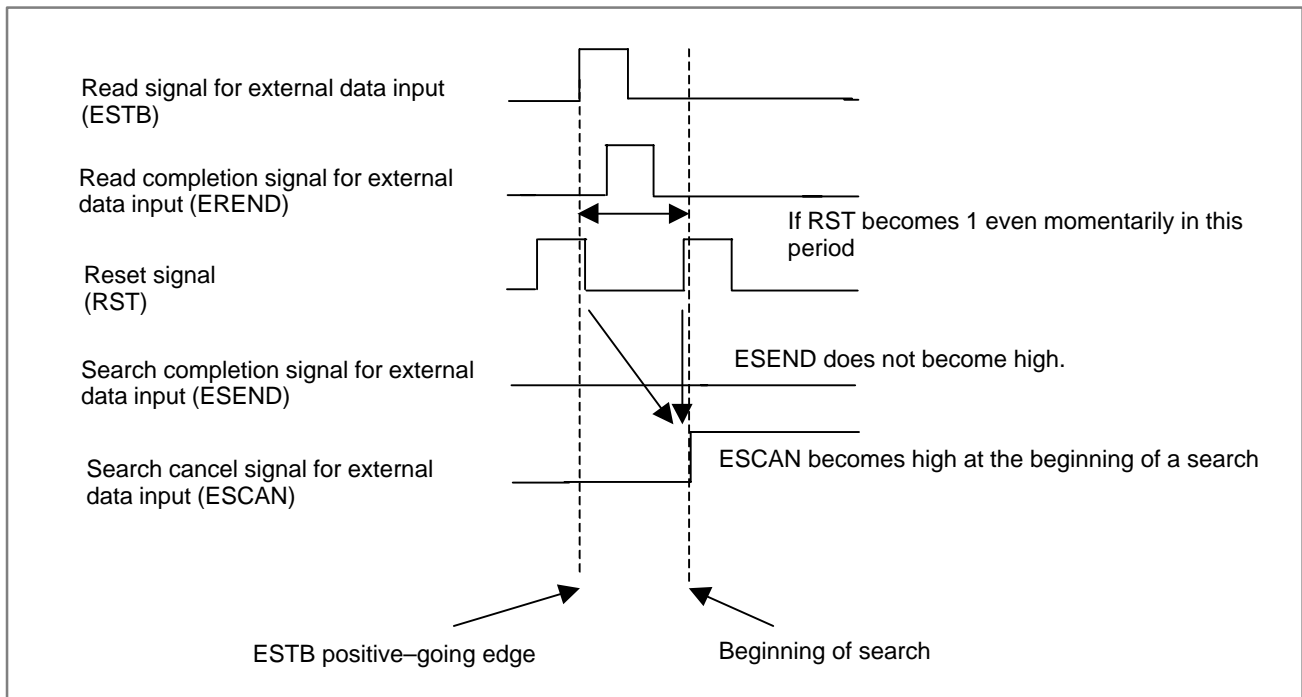
**NOTE**

- 1 The external program number search is valid when parameter ESR no. 6300#4=1.
- 2 In reset state the automatic operation lamp will be off. If the start button is pushed in the cycle operation stop or hold state, search execution starts from the actual position indicated by the pointer.
- 3 When there is no program stored in memory corresponding to the set program number, P/S alarm no. 59 will be activated.
- 4 Program search is not made if the program number is set to "0". Instead when the start button is pushed, execution starts from the position indicated by the pointer.
- 5 Data for the external program number search is accepted regardless of the mode, but the search execution can be made only in the reset state. Therefore, in case that the PMC sequence, which the cycle start is executed by checking search completion signal for external data input only, is used, if the external program number search is commanded twice, the program is executed twice. (When CNC accepts a command of the program number search, the command is not cancelled even if CNC becomes reset state by external reset signal and so on.) (See Fig. 15.2)
If the program execution after reset becomes a problem, please make the PMC sequence not to execute the cycle start after reset.

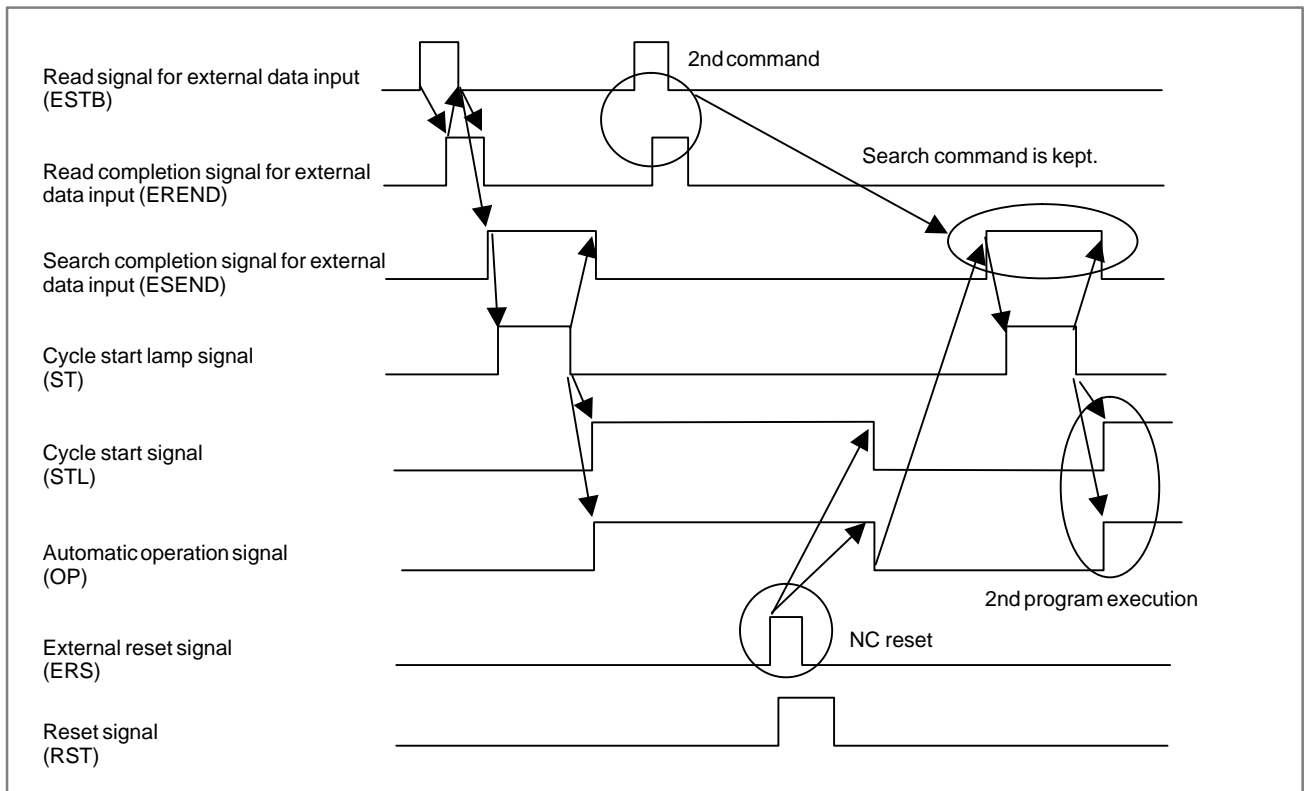

Fig. 15.2

2) External tool compensation

These signals provide for changing the tool compensation amount via the PMC. When the offset number is specified by a program, data input from the PMC is added to the offset amount. The offset amount can also be used as input data itself by specifying the input signal.

When the machine tool is equipped with automatic tools or workpiece measuring functions, the offset amount can be corrected using this function, by inputting the error from the correct value into the CNC via PMC.

If the tool compensation amount is externally input when offset number 0 is specified in a program (a offset cancel) in T series, the workpiece coordinate system shifts by the entered quantity. The external tool compensation range is 0 - ± 7.999 mm or ± 0.7999 inch at a time.

Data specification for external tool compensation (For M series)

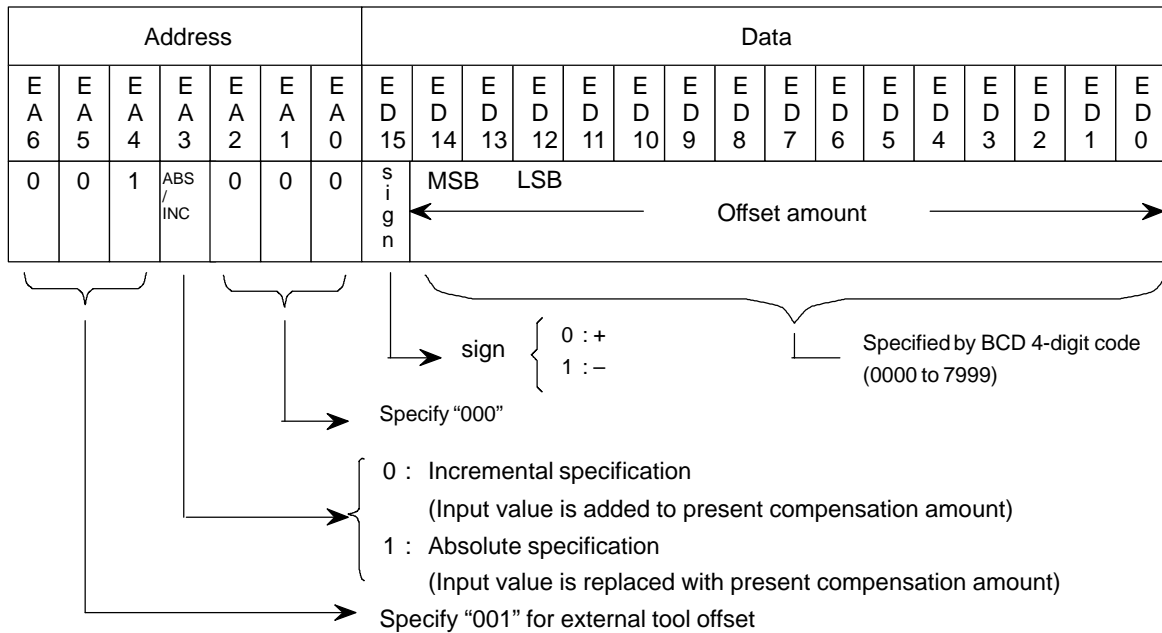

Data specification for external tool compensation (For T series)

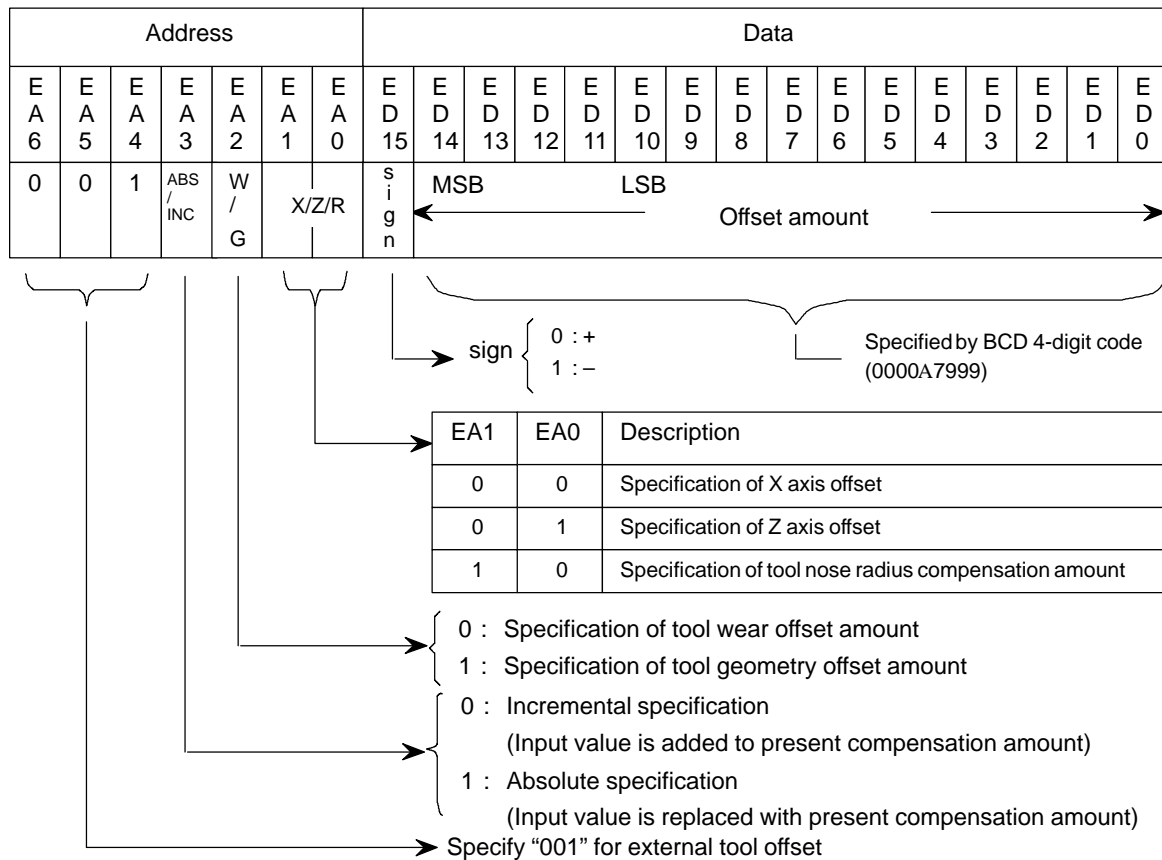

3) External workpiece coordinate system shift

The external workpiece coordinate system shift adjusts the workpiece coordinate system depending on the shift amount set via the PMC. Each axis (parameter No. 1220) has this shift amount, and it is added to all the workpiece coordinate systems for use. The shift amount is not lost by cut off of the power supply. It is not added incrementally, but each input shift amount generates a new shift amount. The range that can be input is 0- ± 7.999 mm or ± 0.7999 inch.

4) External machine coordinate system shift

The machine coordinate system can be shifted by inputting a shift value. When the shift amount is input, compensation is immediately applied to the corresponding axis and the machine starts operation. The position accuracy can be improved by combining this function with sensors.

The specification to shift the axis is the same as that for the external workpiece coordinate system shift.

The compensation value is specified in signals ED0 to ED15 using a binary code ranging from 0 to ± 9.999. This compensation value should be absolute and the amount the machine actually moves on input is the difference from the previously stored value. When a large amount of compensation is applied at one time, an alarm such as “excessive error on stop” may occur. In this case, input the compensation in several smaller increments.

5) External alarm message

(a) External alarm message

The external alarm message holds the CNC in an alarm condition by sending an alarm number from the external device, as well as a message that is displayed on the CRT screen of the CNC. Up to four alarm numbers and messages can be sent at a time; the alarm number ranges from 0 to 999. The CNC displays adds 1000 to the alarm number. The message for one alarm number can be up to 32 characters long. The alarm condition is reset by external data.

(b) External operator message

The external operator message sends the operator message and number from the external unit to the CNC, with a display on the CRT screen of the CNC.

Only one message can be transmitted, with a potential message length of 255 characters. The alarm number ranges from 0 to 999; from 0 to 99, the CNC adds 2000 to the number, while from 100 to 999 the number is not displayed, only the message is displayed.

Data specification method in external message

Item	E A 6	E A 5	E A 4	E A 3	E A 2	E A 1	E A 0	ED15 to ED0 (binary)
Alarm set	1	0	0	0	0	0	0	Alarm No.
Alarm clear	1	0	0	0	0	0	1	Alarm No.
Operator mes- sage list	1	0	0	0	1	0	0	Message No.
Operator mes- sage clear	1	0	0	0	1	0	1	Message No.
Message	1	0	0	0	×	1	1	Character (Note)

NOTE

Two characters are sent at a time (see ISO code given in the table below).

ED15 to ED8 Character code in 1st character.

ED7 to ED0 Character code in 2nd character.

When sending only one character, fill the second slot with a code smaller than 20 and it will be ignored.

Character code table

	0	0	0	0	1	1	1	1
	0	0	1	1	0	0	1	1
	1	1	0	0	1	1	0	0
	0	1	0	1	0	1	0	1
b ₈								
b ₇								
b ₆								
b ₅								
b ₄	0	0	0	0				
b ₃	0	0	0	1				
b ₂	0	0	1	0				
b ₁	0	0	1	1				
	0	1	0	0				
	0	1	0	1				
	0	1	1	0				
	0	1	1	1				
	1	0	0	0				
	1	0	0	1				
	1	0	1	0				
	1	0	1	1				
	1	1	0	0				
	1	1	0	1				
	1	1	1	0				
	1	1	1	1				

SP	0	@	P		-	タ	ミ
!	1	A	Q	#	ア	チ	ム
l	2	B	R	V	イ	ツ	メ
#	3	C	S	W	ウ	テ	モ
\$	4	D	T	"	エ	ト	ヤ
%	5	E	U	.	オ	ナ	ユ
&	6	F	V	ヲ	カ	ニ	ヨ
'	7	G	W	ァ	キ	ヌ	ラ
(8	H	X	イ	ク	ネ	リ
)	9	I	Y	ウ	ケ	ノ	ル
*	:	J	Z	エ	コ	ハ	レ
+	;	K	[オ	サ	ヒ	ロ
,	<	L	o	ヤ	シ	フ	ワ
=	=	M]	ユ	ス	ヘ	ン
.	>	N	^	ヨ	セ	ホ	m
/	?	O	_	ツ	ソ	マ	#

SP : Space code

6) Substituting No. of parts required and No. of parts, machined

Substitution is possible for the No. of parts required and the No. of parts machined.

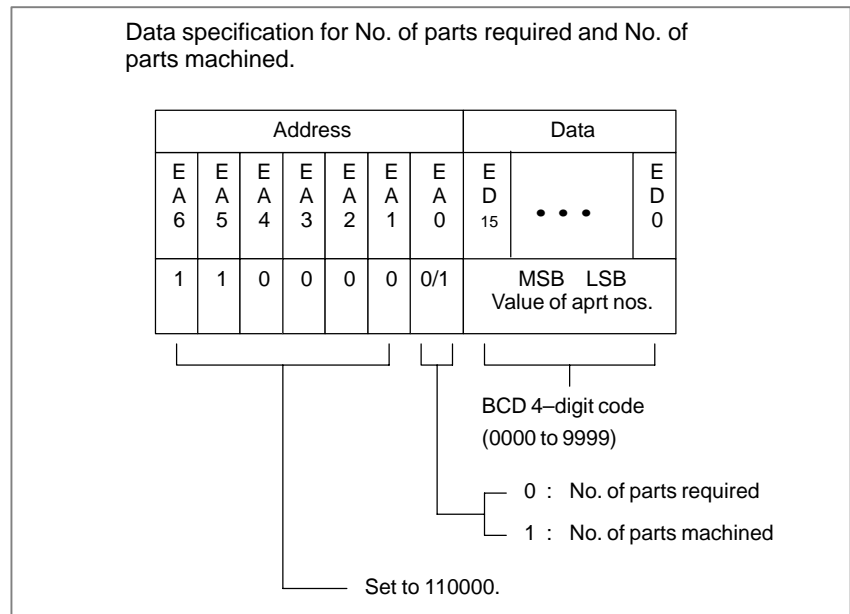

Signals

Data signals for external data input ED0 to ED15 <G000, G001>

[Classification] Input signal

[Function] These signals indicate the entered data.
The use of the 16 code signals varies with the data type.

Address signals for external data input EA0 to EA6 <G002>

[Classification] Input signal

[Function] These signals indicate the type of the entered data.

Read signal for external data input ESTB <G002#7>

[Classification] Input signal

[Function] The signal reports that the address and data are set in external data input.
When the signal is set to “1”, the control unit reads the address and data for external data input.

[Operation] The “basic procedure” describes the procedure for, and operation of, the control unit when the signal turns to “1”.

**Read completion signal
for external data input
EREND <F060#0>**

[Classification] Output signal

[Function] This signal reports that the control unit has finished reading the entered data.

[Operation] The output condition and procedure are described in the “basic procedure.”

**Search completion
signal for external data
input ESEND <F060#1>**

[Classification] Output signal

[Function] This signal reports that program number search, specified by external data input, has been completed.

[Output condition] This signal is set to “1” when:

The program number search specified by external data input is completed.

The signal is set to “0” when:

- An automatic operation is started.
- A reset occurs.

**Search cancel signal for
external data input
ESCAN <F060#2>**

[Classification] Output signal

[Function] Informs the PMC that a program number search has been canceled.

[Output condition] If a reset signal is input between the time the ESTB signal (read signal for external data input) has been input and the time a search would be executed, the external program number search function keeps the search from being executed if the ESC (bit 3 of parameter No. 6300) is 1. The controller sets, to 1, the ESCAN signal (search cancel signal for external data input) rather than the ESEND signal (search completion signal for external data input).

NOTE

This signal is valid only if the ESC parameter (bit 3 of parameter No. 6300) is 1.

Signal address

	#7	#6	#5	#4	#3	#2	#1	#0
G000	ED7	ED6	ED5	ED4	ED3	ED2	ED1	ED0
G001	ED15	ED14	ED13	ED12	ED11	ED10	ED9	ED8
G002	ESTB	EA6	EA5	EA4	EA3	EA2	EA1	EA0
	#7	#6	#5	#4	#3	#2	#1	#0
F060						ESCAN	ESEND	EREND

Parameter

	#7	#6	#5	#4	#3	#2	#1	#0
3202		PSR						

[Data type] Bit

PSR Search for the program number of a protected program

0 : Disabled

1 : Enabled

	#7	#6	#5	#4	#3	#2	#1	#0
6300				ESR	ESC			

[Data type] Bit

ESC Specifies whether the external program number search function is to execute a search if a reset signal is input between the time the ESTB signal (read signal for external data input) is input and the time the search would be executed, as follows:

0 : The search is executed after the CNC is reset.

1 : No search is executed.

ESR External program number search

0 : Disabled

1 : Enabled

Alarm and Message

Number	Message	Description
059	PROGRAM NUMBER NOT FOUND	In an external program number search or external workpiece number search, a specified program number was not found. Otherwise, a program specified for searching is being edited in background processing. Check the program number and external signal. Or discontinue the background editing.
131	TOO MANY EXTERNAL ALARM MESSAGES	Five or more alarms have been generated in external alarm message. Consult the PMC ladder diagram to find the cause.

Number	Message	Description
132	ALARM NUMBER NOT FOUND	No alarm No. concerned exists in external alarm message clear. Check the PMC ladder diagram.
133	ILLEGAL DATA IN EXT. ALARM MSG	Small section data is erroneous in external alarm message or external operator message. Check the PMC ladder diagram.

15.3 EXTERNAL WORKPIECE NUMBER SEARCH

15.3.1 External Workpiece Number Search

General

When several part programs are stored in program storage memory, a program can be searched with the workpiece number search signals PN1 to PN16 from the machine side.

When the cycle operation is actuated in the memory operation mode under reset status, the workpiece number (program number) specified by PN1 to PN16 is searched and executed from the beginning.

Signal

Workpiece Number Search Signal PN1, PN2, PN4, PN8, PN16 <G009#0 to #4>

[Classification] Input signal

[Function] Select the number of a workpiece to be machined in the memory mode. Five code signals are provided. These signals are set in binary code to designate a workpiece number as follows:

Workpiece number search signal					Workpiece number
PN16	PN8	PN4	PN2	PN1	
0	0	0	0	0	00
0	0	0	0	1	01
0	0	0	1	0	02
0	0	0	1	1	03
0	0	1	0	0	04
0	0	1	0	1	05
0	0	1	1	0	06
0	0	1	1	1	07
0	1	0	0	0	08
0	1	0	0	1	09
0	1	0	1	0	10
0	1	0	1	1	11

Workpiece number search signal					Workpiece number
PN16	PN8	PN4	PN2	PN1	
0	1	1	0	0	12
0	1	1	0	1	13
0	1	1	1	0	14
0	1	1	1	1	15
1	0	0	0	0	16
1	0	0	0	1	17
1	0	0	1	0	18
1	0	0	1	1	19
1	0	1	0	0	20
1	0	1	0	1	21
1	0	1	1	0	22
1	0	1	1	1	23
1	1	0	0	0	24
1	1	0	0	1	25
1	1	0	1	0	26
1	1	0	1	1	27
1	1	1	0	0	28
1	1	1	0	1	29
1	1	1	1	0	30
1	1	1	1	1	31

Workpiece number 00 is a special designation indicating “no search”. Thus, workpiece numbers ranges from 01 to 31.

NOTE

These signals are also used to specify a file number for file search during external program input. See Section 13.7, “External Program Input.”

Signal address

	#7	#6	#5	#4	#3	#2	#1	#0
G009				PN16	PN8	PN4	PN2	PN1

Alarm and Message

Number	Message	Description
059	PROGRAM NUMBER NOT FOUND	During an external program number search or external workpiece number search, a specified program number was not found. Otherwise, a program specified for searching is being edited in background processing. Check the program number and external signal. Or discontinue background editing.

Note

NOTE

- 1 This function can be used only in memory operation. It cannot be used during DNC operation and MDI operation.
- 2 Select the program number from O001 to O031.
- 3 Program numbers from O001 to O031 can be used. However, programs corresponding to all the program numbers do not have to be stored in memory.
- 4 When a program corresponding to the specified program number is not stored in memory, an alarm (No. 059) is activated when the start button is pressed.
- 5 Program search is performed only when the start button is pressed in the reset state. When the CNC is in the automatic operation stop state (single block stop, etc.) or pause state (feedhold stop, etc.), program search is not performed even if the start button is pressed and execution is started from the point specified by the present execution pointer.
- 6 To restart a program halfway through, press the start button after sequence number search in MEM mode. The workpiece number search is not performed; program execution starts from the block searched using sequence number search, because the OP signal is set by sequence number search in MEM mode and the CNC reset state is released.
- 7 When the start button is pressed with all PN1 to PN16 all set to "0", program search is not performed but execution is started from the point specified by the present execution pointer. To restart operation from the start of a program which cannot be searched using this function, perform the standard program number search operation (MDI panel operation), set PN1 to PN16 to "0" and press the start button

15.3.2 Expanded External Workpiece Number Search

General

Using the EPN0 to EPN13 (expanded external workpiece number search) signals enables a search for program numbers O0001 to O9999.

Unlike the workpiece number search signal, which triggers an automatic operation after a program search, these signals can make a program search without triggering an automatic operation, because they can be used with the EPNS (expanded workpiece number search start) signal.

Signal

Expanded workpiece number search signals EPN0 to EPN13 <G024, G025#0 to 5>

[Classification] Input signal

[Function] These signals specify the number of the program to be executed in the memory mode, using a binary code. The program numbers that can be specified by these signals range from 1 to 9999.
(Program number 0 is used to make the special specification that "no search is to be made.")

These signals are valid if the EPN parameter No. (bit 1 of parameter No. 3006) is 1.

If the EPN parameter (bit 1 of parameter No. 3006) is 0, the conventional workpiece number search signals PN1, PN2, PN4, PN8, and PN16 <G0009#0 – #4> are valid.

Expanded workpiece number search start signal EPNS <G025#7>

[Classification] Input signal

[Function] This signal causes the workpiece number search function to be executed without performing an automatic operation. When the signal changes from 1 to 0, a search is executed.

Setting the EPS parameter (bit 2 of parameter No. 3006) enables the EPNS signal and disables the conventional search function that is based on the ST (cycle start) signal.

Signal address

	#7	#6	#5	#4	#3	#2	#1	#0
G024	EPN7	EPN6	EPN5	EPN4	EPN3	EPN2	EPN1	EPN0
	#7	#6	#5	#4	#3	#2	#1	#0
G025	EPNS		EPN13	EPN12	EPN11	EPN10	EPN9	EPN8

Parameter

	#7	#6	#5	#4	#3	#2	#1	#0
3006						EPS	EPN	

EPN Workpiece number search signals are assigned to:

0 : PN1, PN2, PN4, PN8, and PN16.

1 : EPN0 to EPN13.

EPS When a program is searched using the workpiece number search function, it is started by:

0 : Automatic operation start signal ST (when automatic operation (memory operation) is started).

1 : Workpiece number search start signal EPNS. (Search is not started by ST.)

NOTE

If this parameter is 1, the ST (cycle start) signal cannot be used to start a search.

Alarm and Message

Number	Message	Description
059	PROGRAM NUMBER NOT FOUND	In an external program number search a specified program number was not found. Otherwise, a program specified for searching is being edited in background processing. Check the program number and external signal. Or discontinue the background editing.

Note

NOTE

1 This function is usable only in the memory mode; it cannot be used in any other mode.

2 If a program that corresponds to a specified program number has not been stored in memory, an alarm (No. 59) is issued when a start signal (ST or EPNS) is input.

15.4 SPINDLE OUTPUT CONTROL BY THE PMC

General

The PMC can control the speed and polarity of each spindle motor, connected by the optional spindle serial output/spindle analog output function.

The first to fourth spindles each have their own individual interfaces. By using a PMC ladder program, the user can control the spindles as desired.

This section describes how to use the PMC to control spindle rotation and provides example applications.

Switching control

This function can be used to specify the following:

- Spindle motor speed (number of rotations)
- Output polarity for each spindle motor (direction of rotation)

Usually, the CNC is used to control the speed and polarity of the first spindle motor. If a multispindle control function is added, the CNC can also control the second to fourth spindle motors.

This function allows the user to select whether the CNC or PMC is used to control the speed and output polarity of the spindle motors.

Specifying the spindle motor speed

The PMC can be used to specify the spindle motor speed upon executing the following:

- Switching the controller from the CNC to the PMC, by issuing SINDx signal
- Setting the spindle motor speed data, calculated by the PMC, in spindle control signals R01Ix to R12Ix

When controlled by the PMC, the spindle motor speed is not affected by any signal (for example, the spindle speed override signal) or parameter settings (for example, the maximum speed clamp parameter) related to the spindle speed command of the CNC spindle control function.

→ If the multispindle control function is added, however, the spindle stop signal *SSTPx <G0027#3-5, G0026#6> can be used to stop a PMC-controlled spindle.

The spindle motor speed data is obtained from the following expression. Its value can range from 0 to 4095:

$$\text{Spindle motor speed data} = \frac{\text{Spindle motor speed}}{\text{Maximum spindle motor speed}} \times 4095$$

Remark) Usually, the spindle speed must be controlled. If a gear train is used to connect the spindle to the spindle motor, first obtain the maximum spindle speed at the maximum spindle motor speed.

$$\text{Spindle motor speed data} = \frac{\text{Spindle speed}}{\text{Maximum spindle speed}} \times 4095$$

By using this expression, the spindle motor speed data can easily be obtained.

Specifying the output polarity for the spindle motor

The PMC can specify the spindle motor output polarity when the following are executed:

- Switching the controller from the CNC to the PMC, by issuing an SSINx signal
- Specifying the output polarity to the SGNx signal

S-code and SF signals

To control the spindle, the PMC may be required to read the S value specified by the CNC.

If the spindle serial output/spindle analog control function is added (if the PMC can control the spindle), the S-code signals <F022 to F025> and SF signal <F007#2> can be output only when several conditions, determined by the CNC spindle control, are satisfied. In some cases, the signals cannot be used under standard conditions.

Specify the related bits of parameter No. 3705 according to the desired application, then use the S-code and SF signals.

Twelve code signals corresponding to the S value (output)

Twelve code signals corresponding to S value R010 to R120 <F036#0 to F037#3> are output to the first spindle motor. The output data is calculated from the results of the CNC spindle control. (See Section 9.3.)

Even while a spindle is subject to PMC control, an S command that is issued to the CNC is converted to spindle output data and output.

The SIND signal determines whether the speed output command, issued to the spindle motor, is obtained from the twelve code signals corresponding to the S value, or from the R01I to R12I signals calculated and specified by the PMC.

The use of this signal may simplify PMC ladder processing used to enable PMC spindle control.

Sample application 1)

Controlling the first and second spindles of a lathe system

→ Share the gear stages between the first and second spindles.

(If the first spindle uses two gears, for example, specify parameters Nos. 3743 and 3744, thus enabling the use of gears 3 and 4 for the second spindle.)

Perform the necessary setting to enable control of the first and second spindles by the PMC.

To specify a rotation command for the first spindle, enter the gears for the first spindle in GR1 and GR2 and obtain the data of the twelve code signals corresponding to the S value. Specify the data as the speed output command for the first spindle in the PMC control interface for the first spindle.

To specify a rotation command for the second spindle, enter the gears to be used for the second spindle in GR1 and GR2 and obtain the data of the twelve code signals corresponding to the S value. Specify the data as the speed output command for the second spindle in the PMC control interface for the second spindle.

Sample application 2)

Using a lathe's orientation function with the stop position of the serial spindle specified externally, specifying the S value as the angle of the stop position for spindle orientation after the spindle positioning mode has been selected

→ Use the gears that are not being used for the first spindle.

(In this application, gear 4 is used to calculate the spindle position. Set parameter No. 3744 to 360.)

Specify the M code used to set the spindle to positioning mode and stop the spindle. Enter gear 4 in GR1 and GR2.

Then, specify a spindle positioning angle with the S command. (To specify the position of 145 degrees, for example, specify S145;.)

Expression $145/360 \times 4095$ is calculated and the result is output to the twelve code signals corresponding to the S value (output signal). Enter the data in external stop position commands SHA00 to SHA11 <G078#0 to G079#3> and perform the orientation.

Signal

PMC spindle control signals

For the first spindle:	SIND, SSIN, SGN <G033#7, #6, #5> R011 to R121 <G032#0 to G033#3>
For the second spindle:	SIND2, SSIN2, SGN2 <G035#7, #6, #5> R0112 to R1212 <G034#0 to G035#3>
For the third spindle:	SIND3, SSIN3, SGN3 <G037#7, #6, #5> R0113 to R1213 <G036#0 to G037#3>
For the fourth spindle:	SIND4, SSIN4, SGN4 <G273#7, #6, #5> R0114 to R1214 <G272#0 to G273#3>

[Classification] Input signal

[Function] The above signals enable the control of a spindle motor by issuing commands from the PMC. Both the speed and polarity of the spindle motor (direction of rotation) can be controlled.

The speed command and polarity are usually specified by the CNC. The use of these signals allows the user to select whether the speed and polarity are controlled by the CNC or PMC.

Even if the multispindle control function is not provided, these signals allow the second to fourth spindles to be controlled.

When the multispindle control function and type A are being used (if the MSI bit, bit 2 of parameter No. 3709, is set to 0), the signals for the second to fourth spindles cannot be used.

- **Details of the signals**

- Signal used to select the spindle motor speed command SIND_x
 - The above signal is used to select whether the spindle motor speed is controlled by the CNC or PMC.
 - 1: The spindle motor is controlled according to speed commands (R01I_x to R12I_x) issued by the PMC.
 - 0: The spindle motor is controlled according to speed commands issued by the CNC. The spindle speed specified with the S command is output.
- Signals used to input the spindle motor speed command issued by the PMC R01I_x to R12I_x
 - If the PMC is being used to control the spindle motor speed command, specify, in binary format, the value obtained using the following expression.

$$\text{Value to be specified} = \frac{\text{Spindle motor speed}}{\text{Maximum spindle motor speed}} \times 4095$$

(Spindle motor speed)

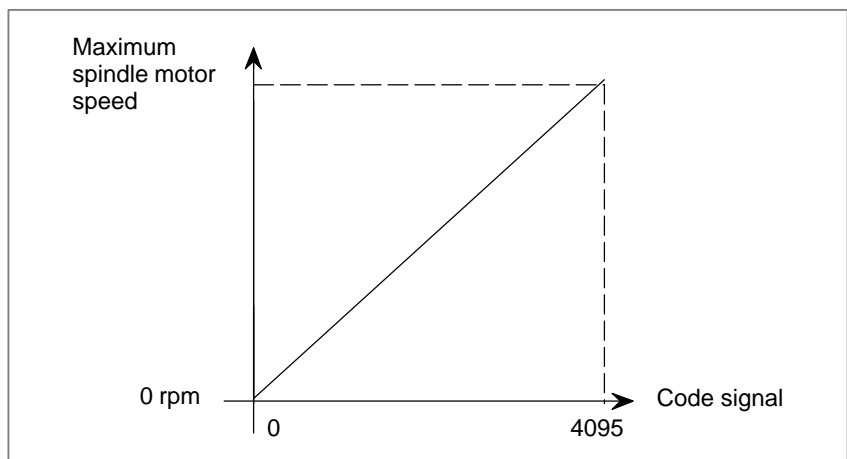

- Signal used to select the polarity of the spindle motor speed command, SSIN_x
 - The above signal selects whether the output polarity of the spindle motor speed command is controlled by the CNC or PMC.
 - 1 : The spindle motor is controlled according to the polarity command (SGN_x) issued by the PMC.
 - 0 : The CNC controls the polarity. The polarity is determined by the TCW and CWM bits (bits 7 and 6 of parameter No. 3706) and the M03 or M04 command.
- Signal used to specify the polarity of the spindle motor selected by the PMC, SGN_x
 - If the PMC is used to control the output polarity of the spindle motor speed command, specify the polarity with this signal.
 - 1 : The output polarity of the spindle is negative.
 - 0 : The output polarity of the spindle is positive.

Twelve code signals corresponding to the S value R010 to R120 <G036#0 to G037#3>

[Classification] Output signal

[Function] The S value, specified in the CNC part program, is converted to the speed output of the spindle motor that is required to control the connected spindle. The converted value is sent to the PMC with twelve code signals, in propotional to the spindle motor speed output.

The speed data, the final result of the CNC spindle control, is output to the spindle motor after the spindle gear ratio, spindle speed override, speed clamp, conversion of the surface speed into the spindle speed by the constant surface speed control command, and other data have been considered.

(See Section 9.3 for an explanation of the relationship between the CNC spindle control and the speed output to the spindle motor.)

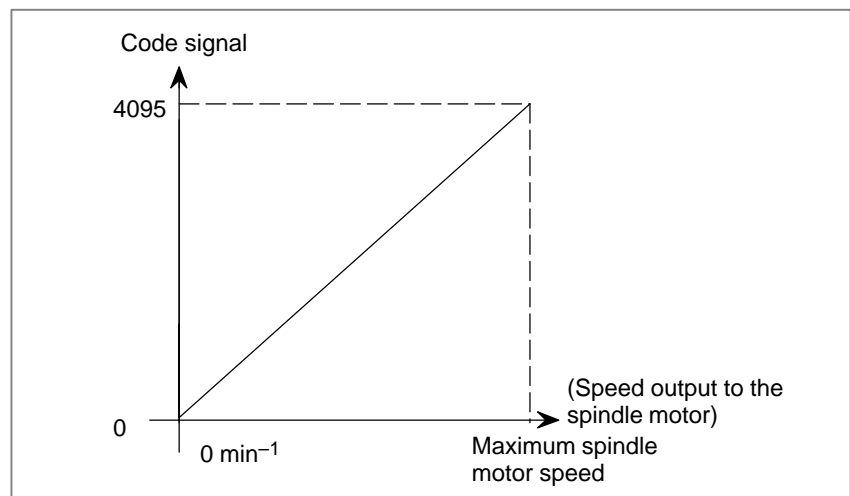

	#7	#6	#5	#4	#3	#2	#1	#0
3705				EVS				ESF
		SFA	NSF					ESF

[Data type] Bit

ESF When the spindle control function (S analog output or S serial output) is used, and the constant surface speed control function is used, or bit 7 (GTT) of parameter No. 3705 is set to 1:

0 : S codes and SF are output for all S commands.

1 : S codes and SF are not output for an S command in constant surface speed control mode (G96 mode) or for an S command used to specify maximum spindle speed clamping (G50S—;).

NOTE

For the T series, this parameter is enabled when bit 4 (EVS) of parameter No. 3705 is set to 1. For the M series, SF is not output:

- (1) For an S command used to specify maximum spindle speed clamping (G92S—;) in constant surface speed control mode
- (2) When bit 5 (NSF) of parameter No. 3705 is set to 1

EVS When the spindle control function (S analog output or S serial output) is used, S codes and SF are:

- 0 : Not output for an S command.
- 1 : Output for an S command.

NOTE

The output of S codes and SF for an S command in constant surface speed control mode (G96), or for an S command used to specify maximum spindle speed clamping (G50S—;) depends on the setting of bit 0 (ESF) of parameter No. 3705.

NSF: When an S code command is issued in constant surface-speed control,

- 0 : SF is output.
- 1 : SF is not output.

SFA: The SF signal is output:

- 0 : When gears are switched
- 1 : Irrespective of whether gears are switched

	#7	#6	#5	#4	#3	#2	#1	#0
3709						MSI		

[Data type] Bit

MSI In multi-spindle control, the SIND signal is valid:

- 0 : Only when the first spindle is selected. (SIND signal for 2nd to 4th spindle become invalid)
- 1 : For each spindle irrespective of whether the spindle is selected. (Each spindle has its own SIND signal.)

3821	Offset-voltage compensation value of the analog output of the third-spindle speed

[Data type] Word

[Unit of data] Velo

[Valid data range] -1024 to 1024

Set the offset-voltage compensation value of the analog output of the third-spindle speed.

[Setting method]

- (1) Set 0 (standard value)
- (2) Specify a spindle speed at which the spindle speed analog output becomes 0.
- (3) Measure output voltage.
- (4) Set the following value to parameter No. 3731.

$$\text{Set value} = \frac{-8191 \times \text{offset voltage (V)}}{12.5}$$
- (5) After the parameter has been set, command again a spindle speed where the spindle speed analog output become 0 and confirm that voltage becomes 0V.

Note

NOTE

- 1 If the spindle fails to move after the PMC issues the spindle motor speed command, check the following:
 Type A is selected (the MSI bit, bit 2 of parameter No. 3709, is set to 0) when the multispindle control function is used.
 → The second to fourth spindles cannot be controlled. The first spindle can be controlled only when the spindle selection signal SWS1 is set to "1".
 The spindle stop signal for each axis is set to "0" when the multispindle control function is being used.
 → Spindle stop signal for each axis *SSTPx <G027#3, #4, #5> stops the spindle.
 M03/M04 is not specified when the CNC is being used to control the output polarity.
 → If the TCW bit, bit 7 of parameter No. 3706, is set to 1, the M03/M04 command issued to the CNC changes the output polarity for the spindle motor. If no M03/M04 command is specified after the CNC is turned on, the specified speed output is not sent to the spindle motor because the output polarity has not been determined.
- 2 The SF signal indicates that output of the S code to the PMC has been completed. The signal does not indicate the end of the command for specifying the spindle speed.
- 3 For an explanation of connecting the second or third spindle, see Sections 9.2 SPINDLE SERIAL OUTPUT/ SPINDLE ANALOG OUTPUT and 9.10 MULTI-SPINDLE CONTROL.
- 4 If the multispindle control function is not being used, the CNC does not issue any commands to the second to fourth spindles. The output polarity is controlled by the SGNx signal. It is not affected by the SSINx signal. The speed output to the spindle motor can be controlled only when the SINDx signal is set to "1".

Reference Item

CONNECTION MANUAL (This manual)	9.2	SPINDLE SERIAL OUTPUT/SPINDLE ANALOG OUTPUT
	9.3	SPINDLE SPEED CONTROL
	9.10	MULTI-SPINDLE CONTROL
	9.15	THREE/FOUR-SPINDLE SERIAL OUTPUT

15.5 EXTERNAL KEY INPUT

General

MDI key codes can be sent from the PMC to CNC by means of interface signals. This allows the CNC to be controlled in the same way as when the operator performs MDI key operation.

Control is realized by exchanging the following interface signals between the PMC and CNC:

Signal name	Abbreviation
External key input mode selection signal (input)	ENBKY
Key code signals (input)	EKC0 to EKC7
Key code read signal (input)	EKSET
Key code read completion signal (output)	EKENB
Key input disable signal (output)	INHKY
Program screen display mode signal (output)	PRGDPL

The processing flow in the PMC is shown below.

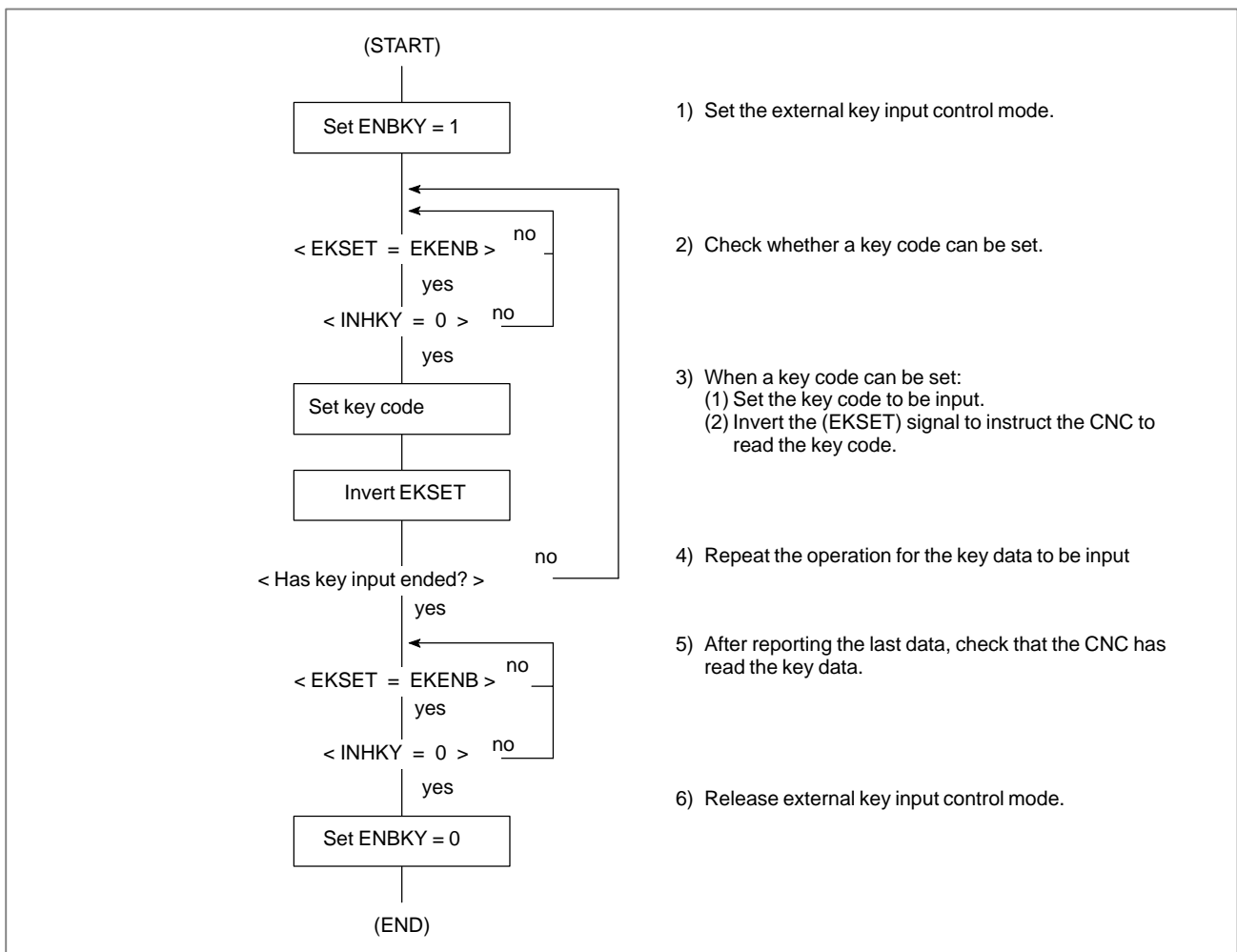

NOTE

Read processing is controlled by exclusive-ORing (XOR) the key code read signal (EKSET) with the read completion signal (EKENB). When the EKSET and EKENB signals differ in their logic, the CNC reads the input key code. Once reading has been completed, the CNC inverts the EKENB signal to match its logic with that of the EKSET signal. In the PMC, on the other hand, a new key code cannot be set while the EKSET and EKENB signals differ in their logic.

Signals
**External key input mode
selection signal
ENBKY <G066#1>**

[Classification] Input signal

[Function] While this signal is turned on “1”, external key input control is enabled. In external key input control mode, any MDI key operations are ignored.

**Key code read signal
EKSET <G066#7>**

[Classification] Input signal

[Function] This signal instructs the CNC to read the input key code.

**Key code signals
EKC0 to EKC7 <G098>**

[Classification] Input signal

[Function] These signals set an input key code. (See the MDI key code table.)

**Key input disable signal
INHKY<F053#0>**

[Classification] Output signal

[Function] While this signal is “1”, no key code is accepted in external key input control mode.

**Program screen display
mode signal PRGDPL
<F053#1>**

[Classification] Output signal

[Function] This signal is on “1” while the CNC is displaying a program screen.

**Key code read
completion signal
EKENB <F053#7>**

[Classification] Output signal

[Function] This signal reports that the CNC has read a key code.

Signal address



	#7	#6	#5	#4	#3	#2	#1	#0
G066	EKSET						ENBKY	
G098	EKC7	EKC6	EKC5	EKC4	EKC3	EKC2	EKC1	EKC0
	#7	#6	#5	#4	#3	#2	#1	#0
F053	EKENB						PRGDPL	INHKY

MDI key code table

Codes in the table are given in hexadecimal. For example, A corresponds to 41H in hexadecimal. RESET corresponds to 90H in hexadecimal.

(Note 1) and (Note 2) are explained below:

NOTE

- 1 For the small keyboard, 0EDH is assigned to  .
 For the standard keyboard, 0EDH is assigned to  .
 0EEH is assigned to  .

- 2 Handling of the soft keys
 [F0] to [F9], [FR], and [FL] in the key code table are the key codes for the soft keys. They are associated with the MDI keys as shown below.

Key configuration for 7-soft key type LCD, or etc. : 5 keys + 2 keys ([F0] to [F4] and [FR], [FL])



[FL] [F4] [F3] [F2] [F1] [F0] [FR]

Key configuration for 12-soft key type LCD, or etc.: 10 keys + 2 keys ([F0] to [F9] and [FR], [FL])

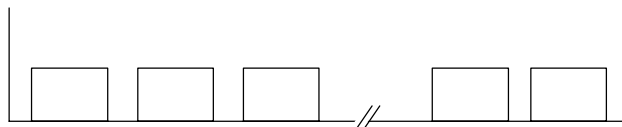

[FL] [F9] [F8] [F7] ... [F1] [F0] [FR]

MDI Key Code Table(00H-7FH)

	0	1	2	3	4	5	6	7
0			Space	0	@	P		
1				1	A	Q		
2				2	B	R		
3			#	3	C	S		
4				4	D	T		
5				5	E	U		
6			&	6	F	V		
7				7	G	W		
8			(8	H	X		
9)	9	I	Y		
A	;		*		J	Z		
	(EOB)							
B			+		K	[
C			,		L			
D			-	=	M]		
E			.		N			
F			/	?	O			

MDI Key Code Table(80H-0FFH)

	8	9	A	B	C	D	E	F
0		RESET						[F0] (Note2)
1								[F1] (Note2)
2								[F2] (Note2)
3								[F3] (Note2)
4		INSERT						[F4] (Note2)
5		DELETE						[F5] (Note2)
6	CAN	ALTER						[F6] (Note2)
7								[F7] (Note2)
8	Cursor →	INPUT					POS	[F8] (Note2)
9	Cursor ←						PROG	[F9] (Note2)
A	Cursor ↓	HELP					OFFSET SET- TING	
B	Cursor ↑						SYSTEM	
C							MES- SAGE	
D							GRAPH (CUSTOM) (Note1)	
E	PAGE ↓						CUSTOM (Note1)	[FR] (Note2)
F	PAGE ↑						FAPT	[FL] (Note2)

15.6 DIRECT OPERATION BY PMC OR OPEN CNC

15.6.1 DNC Operation by the PMC or OPEN CNC (PC with HSSB Connection)

General

Activating memory operation in memory operation mode (MEM) with the direct operation select signal set to 1 enables machining (direct operation=DNC operation) while reading a program stored in the PMC or OPEN CNC.

Signal

Direct operation select signal DMMC <G042#7>

[Classification] Input signal

[Function] Selects the mode (direct operation mode) for performing machining while reading a program stored in the PMC and OPEN CNC.

[Operation] When this signal is set to “1”, the control unit operates as follows:

- When memory operation mode (MEM) is not selected, the control unit ignores this signal.
- When memory operation mode (MEM) is selected, the control unit selects direct operation mode and enables direct operation.

15.6.2 DNC Operation by a PC Connected to the HSSB PORT2

General

You can connect two PCs to the CNC by connecting two HSSB boards to the CNC.

This subsection describes machining (direct operation = DNC operation) performed while reading a program from the PC connected to the second HSSB board.

Setting the HSSB board

For the second HSSB board, set the rotary switch of the board to "6."

DNC operation

To perform DNC operation by using the PC connected to the second HSSB board, perform the following setting and operation.

Setting: I/O CHANNEL (parameter No.20) = 16

Operation: Perform recycle start with the DNCI signal <G04#5> set to 1.

NOTE

The I/O CHANNEL parameter and DNCI signal are also used for DNC operation by I/O devices. (See Section 5.11, "DNC Operation.")

15.7 ONE TOUCH MACRO CALL

Outline

This function enables the following three operations in pushing the switch installed in the machine only by the change in a minimum LADDER program.

- (1) Changes to MEM mode.
- (2) Execution of macro program registered in memory.
- (3) Return to the mode before macro program is executed.

And the program which had been selected before macro program is executed is automatically selected.

This function is effective only in the reset state. That is, this function cannot be used in cycle start state, feed hold state, and automatic operation stop state.

Sequence between PMC and CNC

The signal must be processed between PMC and CNC according to the following procedures.

- Start
 - (1) The macro call start signal (MCSTx) is input from PMC to CNC based on the signal from the macro call switch installed in the machine.
- Mode change
 - (2) CNC outputs the mode notification signal and the mode change request signal (MCRQ) when the macro call start signal (MCSTx) is detected. At this time, MEM mode is notified as the mode notification signal. The macro call executing signal (MCEXE) is output at the same time.
 - (3) PMC must change the mode based on the signal output in the step of above (2).
 - (4) Please set "1" in the mode change completion signal (MCFIN) by PMC when the mode change is completed. If the mode when MCFIN signal is set to "1" is different from the mode specified from CNC in the step of (2), the alarm of P/S5306 is generated.
- Execution of macro program
 - (5) When MCFIN signal is set to "1", CNC executes the macro program.
- End of macro program
 - (6) Please instruct M02 or M30 at the end of the macro program. Moreover, please input external reset signal (ERS) or reset&rewind signal (RRW) with M02 or M30 on the PMC side. The program which had been selected before the macro is executed is automatically selected by reset. The mode change request signal (MCRQ) and mode notification signal are output at the same time. At this time, the mode when macro call start signal (MCSTx) is input is notified as the mode notification signal.

- Return of mode

(7) Please change the mode on the PMC side based on the signal output in the step of above (6).

(8) Please set "1" in Mode change completion signal (MCFIN) on the PMC side when the mode change is completed. The P/S5306 alarm is not checked at this time.

The following Fig.15.7(a) shows the above-mentioned sequence.

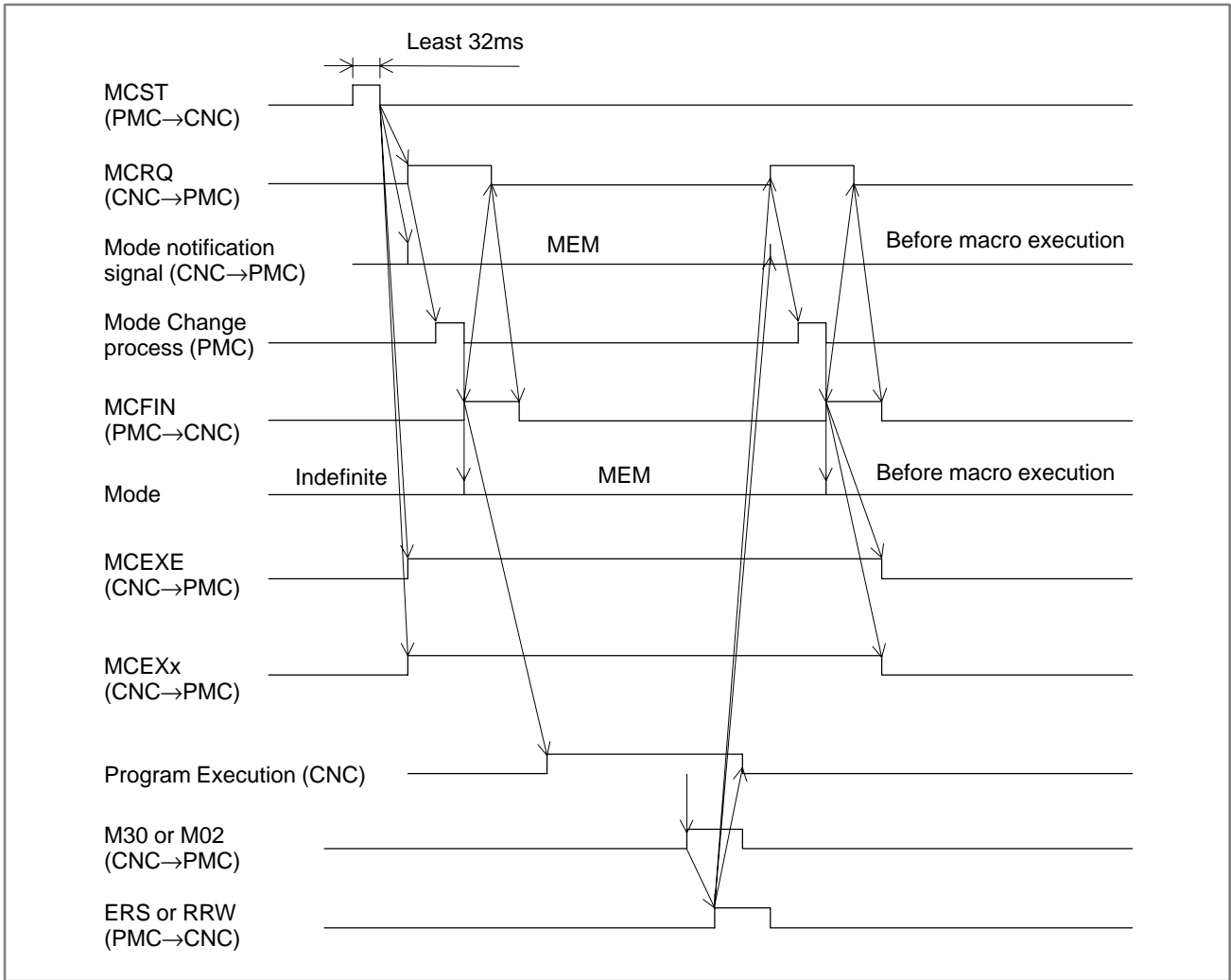

Fig.15.7(a) Timing chart

Interruption of sequence

- Interruption by reset or emergency stop

The abnormal end signal (MCSP) becomes "1" when the operation is interrupted by reset or emergency stop, and the execution of the program is stopped. At this time, the mode change request signal (MCRQ) and mode notification signal are output to recover the mode, and the selection program number is recovered automatically.

Please set "1" in mode change completion signal (MCFIN) on the PMC side to complete the sequence.

● **Feed hold or single block**

The abnormal end signal (MCSP) is not output when stopping in feed hold or single block. Under such a condition, when the cycle start signal (ST) is turned on and off, the continuity of the macro program is executed.

Under such a condition, even if macro call start signal (MCSTx) is turned on and off, it is not effective.

Under such a condition, when reset or emergency stop are input, the operation which is described in Item "Interruption by reset or emergency stop" is executed.

● **Stop by alarm**

When the execution of macro program is stopped by alarm, the abnormal end signal (MCSP) is output.

Under such a condition, when reset or the emergency stop are input, the operation which is described in Item "Interruption by reset or emergency stop" is executed.

Following Fig.15.7(b) shows the timing chart of each signal when the sequence is interrupted by alarm.

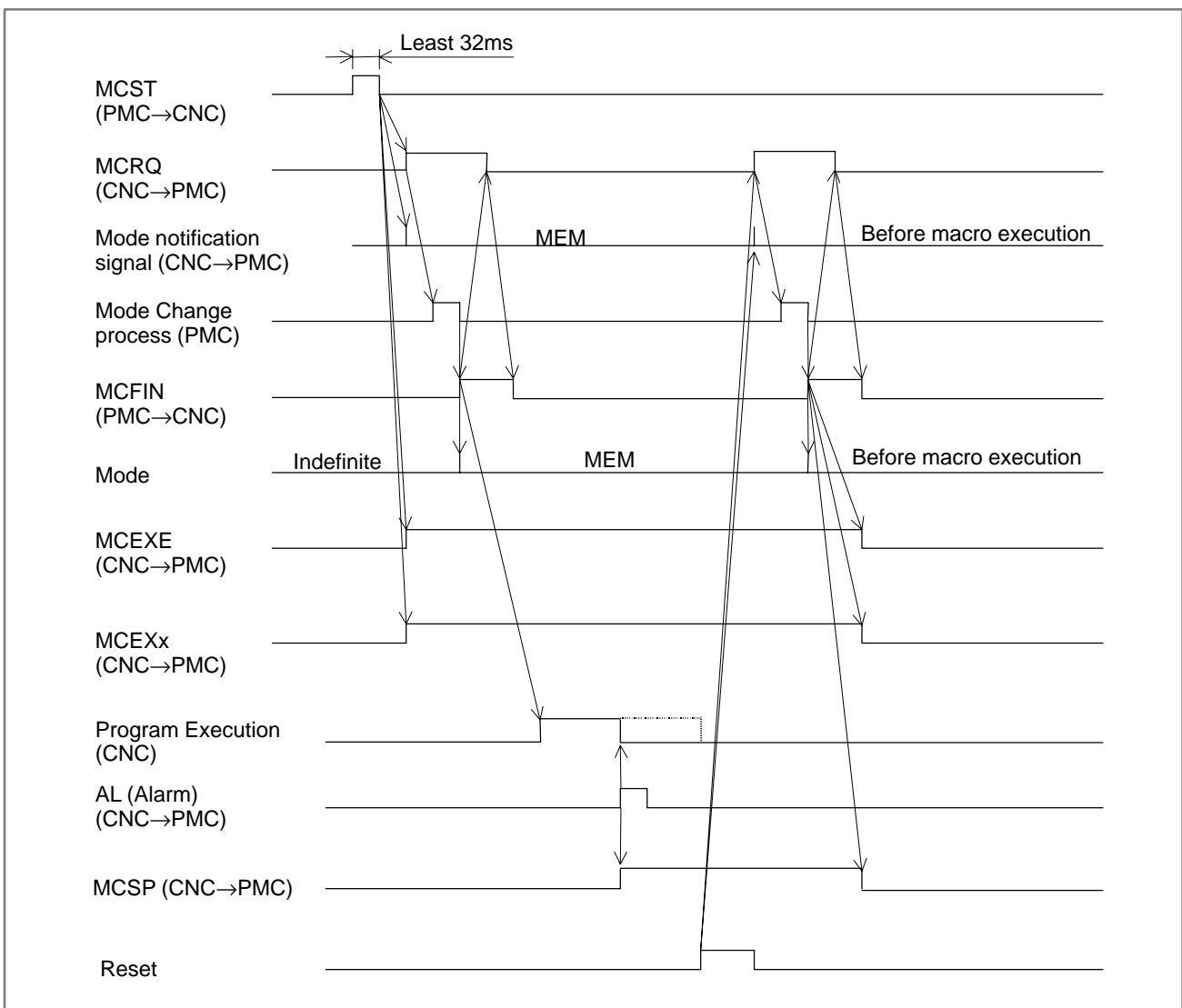

Fig.15.7(b) Timing chart of abnormal end

Notes

NOTE

- 1 Even if the macro call is being executed, mode selection signal (MD1,MD2,MD4) is effective. Therefore, please change the LADDER program to disable the mode change when the macro call executing signal (MCEXE) is "1" when the inconvenience is caused if the mode change is done.
- 2 Other programs cannot be selected by the MDI operation during the automatic operation stop state (single block, etc.) while the macro call is being executed.
- 3 The macro call start signal (MCSTx) is effective only the reset state. The macro call cannot be started at cycle start state or feed hold state or automatic operation stop state.
- 4 The called macro program must end with M02 or M30. And please input external reset signal (ERS) or reset&rewind signal (RRW) from the PMC side when these M codes are executed. If above two condition is not implemented, neither the return of the mode nor the return of the selection program are done after the program ends.
- 5 When the specified program is not registered in the memory, the alarm of P/S059 is generated. The operation in this case becomes the shown in Item "Stop by alarm".
- 6 When O number 8 digit function is used, this function cannot be used.

Signal

Signal list

The list of the signal used by this function is shown as follows. In this function, R signal is used instead of G and F signal. Address "n" in the table below is specified by parameter No.6097.

• PMC → CNC

R(n)	#7 MCST8	#6 MCST7	#5 MCST6	#4 MCST5	#3 MCST4	#2 MCST3	#1 MCST2	#0 MCST1
R(n+1)	#7 MCST16	#6 MCST15	#5 MCST14	#4 MCST13	#3 MCST12	#2 MCST11	#1 MCST10	#0 MCST9
R(n+2)	#7	#6	#5	#4	#3	#2	#1	#0 MCFIN

• CNC → PMC

R(n+3)	#7	#6	#5	#4	#3	#2 MCSP	#1 MCRQ	#0 MCEXE
R(n+4)	#7 ZRNR	#6	#5 DNCIR	#4	#3	#2 MD4R	#1 MD2R	#0 MD1R
R(n+5)	#7 MCEX8	#6 MCEX7	#5 MCEX6	#4 MCEX5	#3 MCEX4	#2 MCEX3	#1 MCEX2	#0 MCEX1
R(n+6)	#7 MCEX16	#6 MCEX15	#5 MCEX14	#4 MCEX13	#3 MCEX12	#2 MCEX11	#1 MCEX10	#0 MCEX9

Macro call start signal**MCSTx****<R(n)#0–R(n+1)#7>****[Classification]** Input signal**[Function]** This signal starts the macro call sequence.**[Operation]** When the standing fall of this signal is detected, CNC starts the corresponding macro program. O number of the program started by the MCST1 signal is specified by parameter No.6096. The sequence is shown in "2.1 sequence between PMC and CNC".**[Action]** Starts the sequence in the Section 2.1.**Macro call executing signal****MCEXE <R(n+3)#0>****[Classification]** Output signal**[Function]** This signal notifies the macro call function is being executed.**[Output condition]** This signal is set to "1" in the following case:

- When CNC detects the standing fall of Macro call start signal (MCSTx).

This signal is set to "0" in the following case:

- When the execution of the macro ends normally.
- When the sequence is completed by the MCFIN signal is input after the sequence is interrupted by reset or emergency stop or the alarm.

Mode change request signal**MCRQ <R(n+3)#1>****[Classification]** Output signal**[Function]** This signal requests the change of the mode.**[Output condition]** This signal is set to "1" in the following case:

- When CNC detects the standing fall of Macro call start signal (MCSTx).
- When M30 or M02 is executed in the macro program, and external reset signal (ERS) or reset&rewind signal (RRW) is input.

This signal is set to "0" in the following case:

- When Mode change completion signal (MCFIN) becomes "1".
- When the sequence is interrupted by reset, emergency stop, or alarm.

Mode notification signal
MD1R, MD2R, MD4R,
DNCIR, and ZRNR
<R(n+4)>

[Classification] Output signal

[Function] This signal notifies the mode which should be changed.

[Output condition] This signal is output in the following case:

- When CNC detects the standing fall of Macro call start signal (MCSTx).
- When M30 or M02 is executed in the macro program, and external reset signal (ERS) or reset&rewind signal (RRW) is input.

Mode change
completion signal
MCFIN <R(n+2)#0>

[Classification] Input signal

[Function] This signal notifies the completion of the mode change to CNC.

[Operation] CNC begins the execution of the program or complete the sequence.

Abnormal end signal
MCSP <R(n+3)#2>

[Classification] Output signal

[Function] This signal notifies the sequence of the macro call is terminated abnormally.

[Output condition] This signal is set to "1" in the following case:

- When the sequence is interrupted by reset or emergency stop or alarm.

This signal is set to "0" in the following case:

- When the mode change completion signal (MCFIN) becomes "1", and the sequence is completed.

Call program
confirmation signal
MCEXx
<R(n+5)#0–R(n+6)#7>

[Classification] Output signal

[Function] This signal notifies the program number called by the macro call. The signal which corresponds to macro call start signal (MCSTx) is output.

[Output condition] This signal is set to "1" in the following case:

- While executing the sequence.

This signal is set to "0" in the following case:

- When the sequence is completed.

Parameter

6095	The number of programs used by the macro call function
------	--

[Data type] Byte

[Unit of data] Number

[Valid data range] 0 to 16

Specify the number of programs used by the macro call function.

For instance, when three is set, macro call start signal MCST1, MCST2, and MCST3 become effective.

When "0" is specified, this function becomes invalid.

6096	The first O number of the program used by the macro call function
------	---

[Data type] Word

[Unit of data] Number

[Valid data range] 1 to 9999

Specify the first O number of the program used by the macro call function. For instance, when 9000 is set, the relation between the MCSTx signal and the started program is as follows.

MCST1 signal : O9000 is called

MCST2 signal : O9001 is called

: :

MCST16 signal : O9015 is called

6097	The first address of the signal group of the macro call function
------	--

[Data type] Word

[Unit of data] Number

[Valid data range] 0 to 65535

Specify the first address of the signal group of the macro call function. (R signal)

For instance, when 500 is set, R500—R506 is used as a signal of the macro call function.

When the number which does not exist is specified, this function becomes invalid.

Alarm and message

Number	Message	Contents
059	PROGRAM NUMBER NOT FOUND	The program of the specified O number is not registered in the memory.
5306	MODE CHANGE ERROR	The mode is not correctly changed at start of sequence.

16

INTERFACE WITH THE POWER MATE CNC



16.1 FANUC SERVO MOTOR β SERIES I/O LINK OPTION MANUAL HANDLE INTERFACE (PERIPHERAL DEVICE CONTROL)

General

This function enables manual handle feed of the Servo Motor β series I/O Link Option (called I/O Link β below) with the manual pulse generator on the host side. A pulse signal generated by the manual pulse generator is sent to the I/O Link β via the I/O Link. By parameter switching, a magnification can be applied to the pulse signal output from the manual pulse generator. This function can be used only with the peripheral device control interface. (This function cannot be used with the direct command interface.)

Function details

After selecting the manual handle mode (MD1 (Y0#0)=0, MD2(Y0#1)=0, MD4(Y0#2)=1), the host sends a magnification (MP1(Y7#4), MP2(Y7#5)) for the manual pulse generator to the I/O Link β to change the manual handle counter.

The I/O Link β drives the motor by reading only a differential of the manual handle counter.

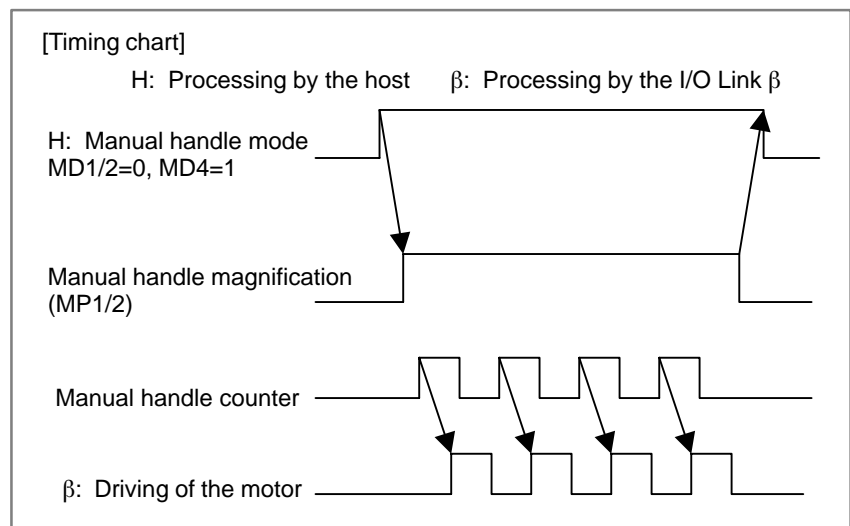

Signal (on the FS16i/18i/21i side)

**Manual handle feed generator selection signals
IOLBH2, IOLBH3
<G199#0, #1>**

[Classification] Input signal

[Function] The signals select a manual pulse generator for feeding the I/O Link β.

[Operation] A manual pulse generator for feeding the I/O Link β is selected with the signals.

Input signal		Manual pulse generator for feeding the I/O Link β
IOLBH3	IOLBH2	
0	0	First manual pulse generator
0	1	Second manual pulse generator
1	0	Third manual pulse generator
1	1	Use prohibited

NOTE

Do not switch between the manual pulse generators in the manual handle mode.

Signal address

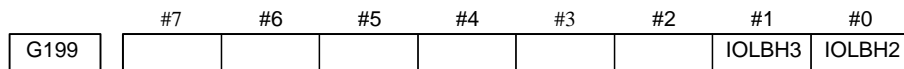

Parameter (on the FS16i/18i/21i side)

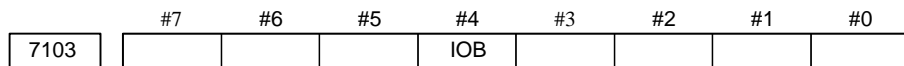

[Data type] Bit

IOB Manual handle feed of the I/O Link β with the I/O Link manual pulse generator is:

- 0 : Disabled.
- 1 : Enabled.

	#7	#6	#5	#4	#3	#2	#1	#0
12330	G17	G16	G15	G14	G13	G12	G11	G10

[Input type] Parameter input

[Data type] Bit

NOTE

When this parameter is set, the power must be turned off before operation is continued.

- #0 G10** When PMC group 0 (channel 1) is a Power Mate or I/O Link β , the pulses from the manual pulse generator connected to the I/O Link are:
 0 : Transferred to that group.
 1 : Not transferred to that group.
- #1 G11** When PMC group 1 (channel 1) is a Power Mate or I/O Link β , the pulses from the manual pulse generator connected to the I/O Link are:
 0 : Transferred to that group.
 1 : Not transferred to that group.
- #2 G12** When PMC group 2 (channel 1) is a Power Mate or I/O Link β , the pulses from the manual pulse generator connected to the I/O Link are:
 0 : Transferred to that group.
 1 : Not transferred to that group.
- #3 G13** When PMC group 3 (channel 1) is a Power Mate or I/O Link β , the pulses from the manual pulse generator connected to the I/O Link are:
 0 : Transferred to that group.
 1 : Not transferred to that group.
- #4 G14** When PMC group 4 (channel 1) is a Power Mate or I/O Link β , the pulses from the manual pulse generator connected to the I/O Link are:
 0 : Transferred to that group.
 1 : Not transferred to that group.
- #5 G15** When PMC group 5 (channel 1) is a Power Mate or I/O Link β , the pulses from the manual pulse generator connected to the I/O Link are:
 0 : Transferred to that group.
 1 : Not transferred to that group.
- #6 G16** When PMC group 6 (channel 1) is a Power Mate or I/O Link β , the pulses from the manual pulse generator connected to the I/O Link are:
 0 : Transferred to that group.
 1 : Not transferred to that group.
- #7 G17** When PMC group 7 (channel 1) is a Power Mate or I/O Link β , the pulses from the manual pulse generator connected to the I/O Link are:
 0 : Transferred to that group.
 1 : Not transferred to that group.

	#7	#6	#5	#4	#3	#2	#1	#0
12331	G1F	G1E	G1D	G1C	G1B	G1A	G19	G18

[Input type] Parameter input

[Data type] Bit

NOTE

When this parameter is set, the power must be turned off before operation is continued.

- #0 G18** When PMC group 8 (channel 1) is a Power Mate or I/O Link β , the pulses from the manual pulse generator connected to the I/O Link are:
 0 : Transferred to that group.
 1 : Not transferred to that group.
- #1 G19** When PMC group 9 (channel 1) is a Power Mate or I/O Link β , the pulses from the manual pulse generator connected to the I/O Link are:
 0 : Transferred to that group.
 1 : Not transferred to that group.
- #2 G1A** When PMC group 10 (channel 1) is a Power Mate or I/O Link β , the pulses from the manual pulse generator connected to the I/O Link are:
 0 : Transferred to that group.
 1 : Not transferred to that group.
- #3 G1B** When PMC group 11 (channel 1) is a Power Mate or I/O Link β , the pulses from the manual pulse generator connected to the I/O Link are:
 0 : Transferred to that group.
 1 : Not transferred to that group.
- #4 G1C** When PMC group 12 (channel 1) is a Power Mate or I/O Link β , the pulses from the manual pulse generator connected to the I/O Link are:
 0 : Transferred to that group.
 1 : Not transferred to that group.
- #5 G1D** When PMC group 13 (channel 1) is a Power Mate or I/O Link β , the pulses from the manual pulse generator connected to the I/O Link are:
 0 : Transferred to that group.
 1 : Not transferred to that group.
- #6 G1E** When PMC group 14 (channel 1) is a Power Mate or I/O Link β , the pulses from the manual pulse generator connected to the I/O Link are:
 0 : Transferred to that group.
 1 : Not transferred to that group.
- #7 G1F** When PMC group 15 (channel 1) is a Power Mate or I/O Link β , the pulses from the manual pulse generator connected to the I/O Link are:
 0 : Transferred to that group.
 1 : Not transferred to that group.

	#7	#6	#5	#4	#3	#2	#1	#0
12332	G27	G26	G25	G24	G23	G22	G21	G20

[Input type] Parameter input

[Data type] Bit

NOTE

When this parameter is set, the power must be turned off before operation is continued.

- #0 G20** When PMC group 0 (channel 2) is a Power Mate or I/O Link β , the pulses from the manual pulse generator connected to the I/O Link are:
 0 : Transferred to that group.
 1 : Not transferred to that group.
- #1 G21** When PMC group 1 (channel 2) is a Power Mate or I/O Link β , the pulses from the manual pulse generator connected to the I/O Link are:
 0 : Transferred to that group.
 1 : Not transferred to that group.
- #2 G22** When PMC group 2 (channel 2) is a Power Mate or I/O Link β , the pulses from the manual pulse generator connected to the I/O Link are:
 0 : Transferred to that group.
 1 : Not transferred to that group.
- #3 G23** When PMC group 3 (channel 2) is a Power Mate or I/O Link β , the pulses from the manual pulse generator connected to the I/O Link are:
 0 : Transferred to that group.
 1 : Not transferred to that group.
- #4 G24** When PMC group 4 (channel 2) is a Power Mate or I/O Link β , the pulses from the manual pulse generator connected to the I/O Link are:
 0 : Transferred to that group.
 1 : Not transferred to that group.
- #5 G25** When PMC group 5 (channel 2) is a Power Mate or I/O Link β , the pulses from the manual pulse generator connected to the I/O Link are:
 0 : Transferred to that group.
 1 : Not transferred to that group.
- #6 G26** When PMC group 6 (channel 2) is a Power Mate or I/O Link β , the pulses from the manual pulse generator connected to the I/O Link are:
 0 : Transferred to that group.
 1 : Not transferred to that group.
- #7 G27** When PMC group 7 (channel 2) is a Power Mate or I/O Link β , the pulses from the manual pulse generator connected to the I/O Link are:
 0 : Transferred to that group.
 1 : Not transferred to that group.

	#7	#6	#5	#4	#3	#2	#1	#0
12333	G2F	G2E	G2D	G2C	G2B	G2A	G29	G28

[Input type] Parameter input

[Data type] Bit

NOTE

When this parameter is set, the power must be turned off before operation is continued.

- #0 G28** When PMC group 8 (channel 2) is a Power Mate or I/O Link β , the pulses from the manual pulse generator connected to the I/O Link are:
 0 : Transferred to that group.
 1 : Not transferred to that group.
- #1 G29** When PMC group 9 (channel 2) is a Power Mate or I/O Link β , the pulses from the manual pulse generator connected to the I/O Link are:
 0 : Transferred to that group.
 1 : Not transferred to that group.
- #2 G2A** When PMC group 10 (channel 2) is a Power Mate or I/O Link β , the pulses from the manual pulse generator connected to the I/O Link are:
 0 : Transferred to that group.
 1 : Not transferred to that group.
- #3 G2B** When PMC group 11 (channel 2) is a Power Mate or I/O Link β , the pulses from the manual pulse generator connected to the I/O Link are:
 0 : Transferred to that group.
 1 : Not transferred to that group.
- #4 G2C** When PMC group 12 (channel 2) is a Power Mate or I/O Link β , the pulses from the manual pulse generator connected to the I/O Link are:
 0 : Transferred to that group.
 1 : Not transferred to that group.
- #5 G2D** When PMC group 13 (channel 2) is a Power Mate or I/O Link β , the pulses from the manual pulse generator connected to the I/O Link are:
 0 : Transferred to that group.
 1 : Not transferred to that group.
- #6 G2E** When PMC group 14 (channel 2) is a Power Mate or I/O Link β , the pulses from the manual pulse generator connected to the I/O Link are:
 0 : Transferred to that group.
 1 : Not transferred to that group.
- #7 G2F** When PMC group 15 (channel 2) is a Power Mate or I/O Link β , the pulses from the manual pulse generator connected to the I/O Link are:
 0 : Transferred to that group.
 1 : Not transferred to that group.

Signal (on the I/O Link β side)

Mode selection signals

MD1, MD2, MD4
<Yy+0#0, #1, #2>

[Classification] CNC (host) → I/O Link β

[Function] The signals select an operation mode of the I/O Link β .

[Operation] The manual handle feed mode of the I/O Link β is selected with the signals.

Input signal		
MD4	MD2	MD1
1	0	0

NOTE

- 1 Turn the manual pulse generator after placing it in the manual handle mode.
- 2 Do not switch between the modes during manual handle operation of the I/O Link β servo unit.

Incremental feed signals

MP1, MP2 <Yy+7#4, #5>

[Classification] CNC (host) → I/O Link β

[Function] The signals select a magnification for the manual handle.

[Operation] The I/O Link β drives the motor in the manual handle mode by the pulses obtained by multiplying the number of input pulses of the manual pulse generator by a magnification set by the signals.

Input signal		Amount of travel per division of the manual pulse generator
MP2	MP1	
0	0	1 user unit
0	1	10 user units
1	0	100 user units
1	1	(M/N) user units (M = Parameter No. 62, N = Parameter No. 63)

NOTE

- 1 The signals are valid when bit 5 (MP) of parameter No. 5 for the I/O Link β is set to 1.
- 2 The signals are valid only in the manual handle mode.
- 3 The signals are used also as rapid traverse override signals. In the manual handle mode, the signals function as the incremental feed signals. In modes other than the manual handle mode, the signals function as the rapid traverse override signals. When the mode is switched from the manual handle mode to another mode, the setting of the signals need to be returned to the setting of the rapid traverse override signals.

Signal address

	#7	#6	#5	#4	#3	#2	#1	#0
Yy+0						MD4	MD2	MD1
	#7	#6	#5	#4	#3	#2	#1	#0
Yy+7			MP2	MP1				

Parameter (on the I/O Link β side)

	#7	#6	#5	#4	#3	#2	#1	#0
005			MP	IOH				

[Data type] Bit

IOH Manual handle feed via the I/O Link is:
 0 : Disabled.
 1 : Enabled.

CAUTION

When IOH is set to 1, be sure to set bit 6 (EXPLS) of parameter No. 3 on the I/O link β side to 0.

MP In manual handle feed, four-stage magnification setting using the MP1/MP2 signals for input manual handle pulses is:
 0 : Disabled.
 1 : Enabled.

17 EMBEDDED ETHERNET FUNCTION



This chapter describes the specifications of the embedded Ethernet function for Series *16i/18i/21i/20i/160i/180i/210i/160is/180is/210is-B*.

17.1 EMBEDDED ETHERNET AND PCMCIA ETHERNET

The embedded Ethernet function can be used by selecting one of two types of devices: the embedded Ethernet port and PCMCIA Ethernet card. The PCMCIA Ethernet card is to be inserted into the memory card slot to the left of the front LCD for temporary communication.

NOTE

- 1 Use the PCMCIA Ethernet card for temporary communication only. Do not use the PCMCIA Ethernet card for routine communication.
- 2 The PCMCIA Ethernet card is to be inserted into the memory card slot to the left of the LCD. This means that some part of the card is projected. When using the PCMCIA Ethernet card, be careful not to damage the card by hitting the card with an object.
After using the PCMCIA Ethernet card, remove the card immediately to prevent the card from being damaged.
- 3 With Series 21i/20i/210i/210is-B, the embedded Ethernet port cannot be used.
- 4 This section assumes that the PCMCIA Ethernet card is inserted into the Series 16i/18i/21i/20i-B CNC. When inserted into the Series 160i/180i/210i/160is/180is/210is CNC, the PCMCIA Ethernet card is not a embedded Ethernet card.

17.2 LIST OF FUNCTIONS

With the embedded Ethernet function, the following functions can be operated:

- FACTOLINK function
- FOCAS1/Ethernet function
- DNC1/Ethernet function
- FTP file transfer function

NOTE

With the series 20i-B, the "FACTOLINK function" and "DNC1/Ethernet function" are not operated. The "FOCAS1/Ethernet function" can communicate only with the following application software products. The function cannot communicate with any application software created by users using "FANUC Open CNC FOCAS1/Ethernet CNC/PMC Data Window Library."

- Servo Guide
- FANUC LADDER-III
- Machine Remote Diagnosis Package

17.2.1 FACTOLINK Function

With the FACTOLINK function, data can be displayed on the CNC screen, and NC data can be transferred by operations on the NC. For details, refer to "FANUC FACTOLINK Script Function OPERATOR'S MANUAL (B-75054EN)".

NOTE

The FACTOLINK function is usable with the control software for the embedded Ethernet function series 656A edition 02 or later.

Screen display

Data created by a personal computer can be displayed on the NC screen by operations on the NC.

NC data transfer

The following NC data can be transferred by operations on the NC:

- NC program
- NC file data
 - Parameter
 - Ladder program
 - C language executor in executable form
 - Macro executor in executable form
 - NC system file
- PMC data
 - Addresses T, K, C, D

Logging

Machine state information can be automatically sent to the personal computer.

17.2.2 FOCAS1/Ethernet Function

The FOCAS1/Ethernet function allows a personal computer to remotely control and monitor the CNC. The FOCAS1/Ethernet function can transfer a wider range of NC data than the DNC1/Ethernet function. For details, refer to "FANUC Open CNC FOCAS1/Ethernet CNC/PMC Data Window Library Description".

NC data transfer

The following NC data can be transferred by operations on the personal computer:

- Data related to control axes/spindles
 - Absolute position
 - Relative position
 - Machine position
 - Remaining travel amount
 - Actual speed
- NC program
- Part program storage directory information
- NC data file
 - Parameter
 - Tool offset value
 - Custom macro variable
 - Workpiece origin offset
 - Setting data
 - P code macro variable
 - Pitch error compensation
- Tool life management data
- History data
 - Operation history data
 - Alarm history data
- Servo-/spindle-related data
- Data related to waveform diagnosis
- Modal data
- Diagnosis data
- A/D conversion data
- Alarm information
- NC system identification information
- PMC data
 - Addresses G, F, Y, X, A, R, T, K, C, D
 - Extended nonvolatile data

Remote operation

From the personal computer, the following operations can be performed:

- NC program selection
- NC program deletion
- External reset

NOTE

With the FOCAS1/Ethernet function of the embedded Ethernet function, DNC operation cannot be performed.

17.2.3 DNC1/Ethernet Function

The DNC1/Ethernet function allows a personal computer to remotely control and monitor the CNC. The DNC1/Ethernet function provides software libraries in a simpler function call format when compared with the FOCAS1/Ethernet function.

For details, refer to “FANUC Personal Computer FA System Windows NT Version OPERATOR’S MANUAL (B-75044EN)”.

NC data transfer

The following NC data can be transferred by operations on the personal computer:

- NC program
- Part program storage directory information
- NC file data
 - Parameter
 - Tool offset value
 - Custom macro variable
- Alarm information
- NC system identification information
- PMC data
 - Addresses G, F, Y, X, A, R, T, K, C, D

Remote operation

From the personal computer, the following operations can be performed:

- NC program selection
- NC program deletion
- External reset

NOTE

With the DNC1/Ethernet function of the embedded Ethernet function, DNC operation cannot be performed.

Differences between the FOCAS1/Ethernet function and DNC1/Ethernet function

Compared with the FOCAS1/Ethernet function, the DNC1/Ethernet function provides software libraries in a simpler function call format for frequently used functions.

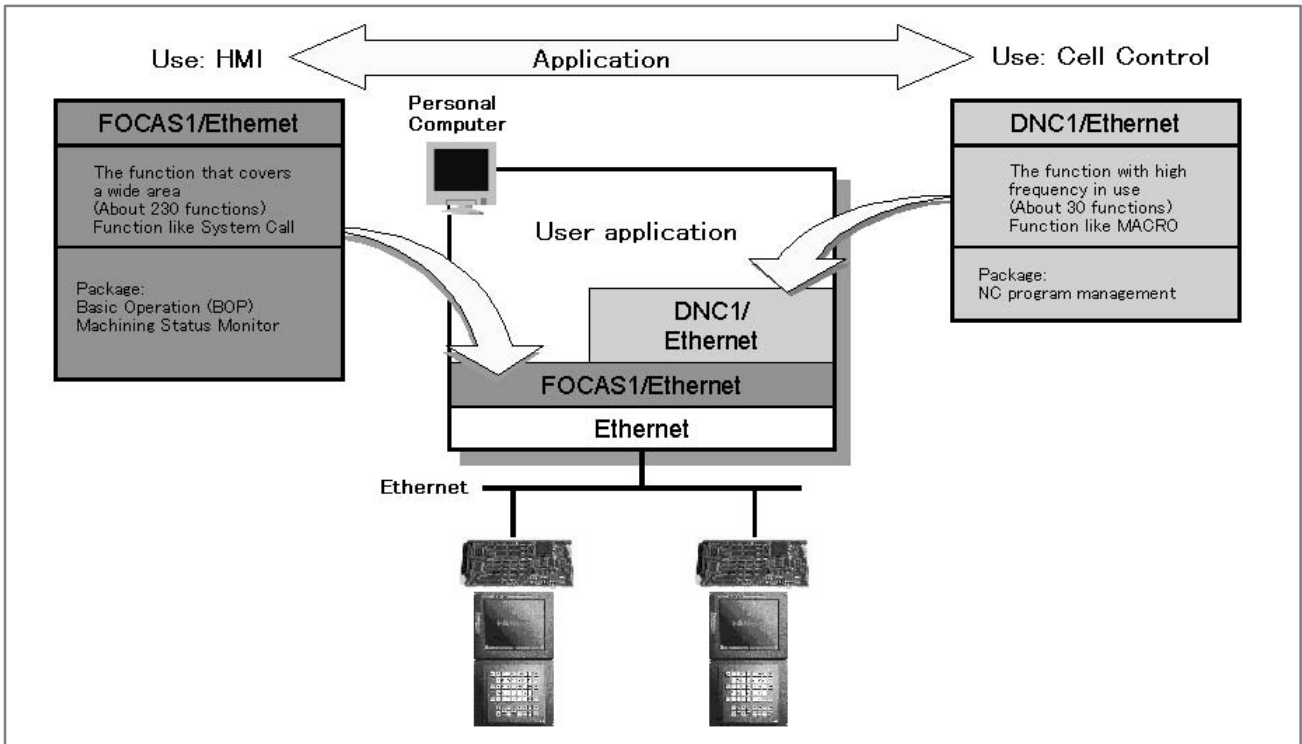

17.2.4 FTP File Transfer Function

The FTP file transfer function transfers files with FTP. The function can read and punch NC programs and various types of NC data.

NOTE

The FTP file transfer function is usable with the control software for the embedded Ethernet function series 656A edition 02 or later and series 656V edition 01 or later.

NC data transfer [Personal computer ↔ Part program storage]

The following NC data can be transferred by operations on the NC:

- NC program
- NC file data
 - Parameter
 - Tool offset value
 - Workpiece origin offset value
 - Pitch error compensation
 - M code group (Series 16i/18i/160i/180i/160is/180is-B only)
- History data
 - Operation history data

17.2.5 Functional Differences between the Embedded Ethernet Function and the Ethernet Function Based on the Option Board

The table below indicates the differences between the embedded Ethernet function and the Ethernet function based on the option board.

	Embedded Ethernet	Option board
FOCAS1/Ethernet function	Available	Available
CNC screen display function	Not available	Available
DNC operation	Not available	Available
Data Server function	Not available (Note 1)	Available
FACTOLINK function	Available	Available

NOTE

- 1 The embedded Ethernet function includes the FTP file transfer function.

This function is almost equivalent to the NC data transfer function in the FTP mode of the Data Server function of the option board.

- 2 Compared with the option board, the embedded Ethernet function allows a smaller number of FOCAS1/Ethernet clients to be connected simultaneously.

	Embedded Ethernet	Ethernet board	Fast Ethernet board
Number of clients that can be connected simultaneously	5 clients maximum	10 clients maximum	20 clients maximum
Number of personal computers that can be connected simultaneously	1 unit (recommended)	10 units maximum	20 units maximum

- 3 Communications using the embedded Ethernet function is processed by the CPU of the CNC. This means that the operation state of the CNC can affect the performance of communication based on the embedded Ethernet function, and communication based on the embedded Ethernet function can affect the processing of the CNC.

The embedded Ethernet function has lower priority than axis-by-axis processing such as automatic operation processing and manual operation. So, when automatic operation is being performed or many controlled axes are involved, communication may become slower.

On the contrary, the embedded Ethernet function has higher priority over CNC screen display processing, C language executor processing (excluding high-level tasks), and macro executor processing (excluding execution macros). So, communication based on the embedded Ethernet function can decrease the performance of such processing.

- 4 Note that when the embedded Ethernet function is connected to an intranet that handles large volumes of broadcast data, for example, the processing of broadcast data can take a longer time, resulting in a decrease in performance of processing such as CNC screen display processing.

17.3 SETTING THE EMBEDDED ETHERNET FUNCTION

This section describes the setting of the parameters for the embedded Ethernet function.

17.3.1 Parameter Setting of the FACTOLINK Function

This subsection describes the settings required to operate the FACTOLINK function when the embedded Ethernet function is used.

17.3.1.1 Notes on using the FACTOLINK function for the first time

CAUTION

When using the embedded Ethernet function for the first time, make various settings including IP address setting carefully and conduct a communication test sufficiently, consulting with your network manager.

Note that if an incorrect IP address is set, for example, the entire network may suffer from a communication error.

NOTE

1 When the FACTOLINK function is used, the optional function corresponding to a CNC used is required.

Series 16*i*-TB A02B-0281-S708

Series 16*i*-MB A02B-0282-S708

Series 18*i*-TB A02B-0283-S708

Series 18*i*-MB A02B-0284-S708

Series 21*i*-TB A02B-0285-S708

Series 21*i*-MB A02B-0286-S708

2 With the FACTOLINK function, only one FACTOLINK server can be connected to one CNC.

17.3.1.2 FACTOLINK parameter setting screen

On the Ethernet parameter setting screen, set the parameters for operating the FACTOLINK function.

Display

Procedure

- 1 Place the CNC in the MDI mode.
- 2 Press the function key  .
- 3 Press the continuous menu key at the right end of the soft key display.
- 4 Press the [ETHPRM] soft key. The Ethernet parameter setting screen appears. The Ethernet functions currently available are displayed.



The upper row displays the usable embedded Ethernet function device.

The embedded port or PCMCIA card is displayed.



The lower row displays the usable Ethernet option boards. When no option board is installed, no information is displayed.

- 5 By pressing the [EMBEDD] soft key, the parameters for the embedded Ethernet port can be set.
By pressing the [PCMCIA] soft key, the parameters for the PCMCIA Ethernet card can be set.

NOTE

The parameters for the embedded Ethernet port and the parameters for the PCMCIA Ethernet card are independent of each other.

- 6 By using the MDI keys and soft keys, enter and update data.

- 7 Switch the screen display with the page keys  .

If data is already registered, the data is displayed.

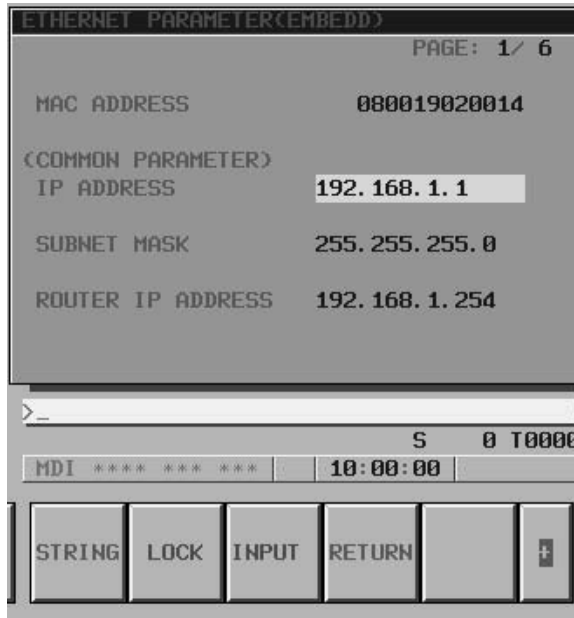

Display item and setting items

Display item related to the embedded Ethernet function

The item related to the embedded Ethernet function is displayed.

Item	Description
MAC ADDRESS	Embedded Ethernet MAC address

Embedded Ethernet TCP/IP setting items

Set the TCP/IP-related items of the embedded Ethernet.

Item	Description
IP ADDRESS	Specify the IP address of the embedded Ethernet. (Example of specification format: "192.168.1.1")
SUBNET MASK	Specify a mask address for the IP addresses of the network. (Example of specification format: "255.255.255.0")
ROUTER IP ADDRESS	Specify the IP address of the router. Specify this item when the network contains a router. (Example of specification format: "192.168.1.254")

FACTOLINK setting items

Set the items related to the host computer with which the FACTOLINK server operates.

Item	Description
IP ADDRESS	Specify the IP address of a personal computer to be accessed by the FACTOLINK function. (Example of specification format: "192.168.1.100")
PORT NUMBER	Specify a port number to be used with the FACTOLINK function. The valid input range is 5001 to 65535. A specified port number must match "ocsnc" of the "services" file of the personal computer. For details, refer to "FANUC FACTOLINK Script Function OPERATOR'S MANUAL (B-75054EN)".

17.3.1.3 Parameters

Parameter The NC parameters related to the FACTOLINK function are described below.

0802	Communicationchannel
------	----------------------

[Data type] Byte

[Valid data range] 21: Select the embedded Ethernet.

	#7	#6	#5	#4	#3	#2	#1	#0
0810			MONO	TIME				BGS

[Data type] Bit

BGS When the FACTOLINK screen is not displayed:

0 : Logging is performed in the background.

1 : Logging is not performed.

TIME Selects the time display format:

0 : "04/11/12 00:00" format is used.

1 : "Wed Nov 12 00:00:00" format is used.

MONO When the FACTOLINK screen is displayed:

0 : Two-tone monochrome display is used.

1 : Color display is used.

0811	Type of logging
------	-----------------

[Data type] Byte

[Valid data range] 0, 1, 10, 20, 21

0 : D address area

1 : R address area

10 : Fixed data only

20 : D address area + fixed data

21 : R address area + fixed data

0812	PMC address for logging data
------	------------------------------

[Data type] Word

[Valid data range] 0 to 65535

Set a start PMC address for storing logging data.

0813	Data length of logging data
------	-----------------------------

[Data type] Word

[Unit of data] Number of bytes

[Valid data range] 0 to 65535

Set the data length of logging data.

0814	Trigger PMC address for logging
------	---------------------------------

[Data type] Word

[Valid data range] 0 to 65535

Set a PMC address that serves as a trigger for specifying logging data.

0815	Logging data transmission interval
------	------------------------------------

[Data type] Double-word

[Unit of data] Seconds

[Valid data range] 0 to 4294967295

Set a time interval used for transmitting logging data (fixed data only).
If 0 is set, logging data is transmitted at connection time only.

0820	Machine name posted to the host computer (1st byte)
0821	Machine name posted to the host computer (2nd byte)
0822	Machine name posted to the host computer (3rd byte)
0823	Machine name posted to the host computer (4th byte)
0824	Machine name posted to the host computer (5th byte)
0825	Machine name posted to the host computer (6th byte)
0826	Machine name posted to the host computer (7th byte)
0827	Machine name posted to the host computer (8th byte)
0828	Machine name posted to the host computer (9th byte)

[Data type] Byte

[Valid data range] 32 to 126

Set a machine name that is unique to each CNC and is required for the host computer to identify each CNC. Use ASCII codes in decimal for alphanumeric characters and blanks to set a machine name.

	#7	#6	#5	#4	#3	#2	#1	#0
3111	NPA							

[Data type] Bit

NPA When an alarm is issued while the FACTOLINK screen is displayed:

0 : The screen display does not switch to the alarm screen.

1 : The screen display switches to the alarm screen.

**17.3.1.4
Using the FACTOLINK
function on a small
network**

An example of minimum setting required to operate the FACTOLINK function on a small network is provided below.

In this example, one personal computer is connected to two CNCs through FACTOLINK.

- On Personal Computer 1, the server of the FACTOLINK function operates.
- On CNC 1 and CNC 2, the client of the FACTOLINK function operates.

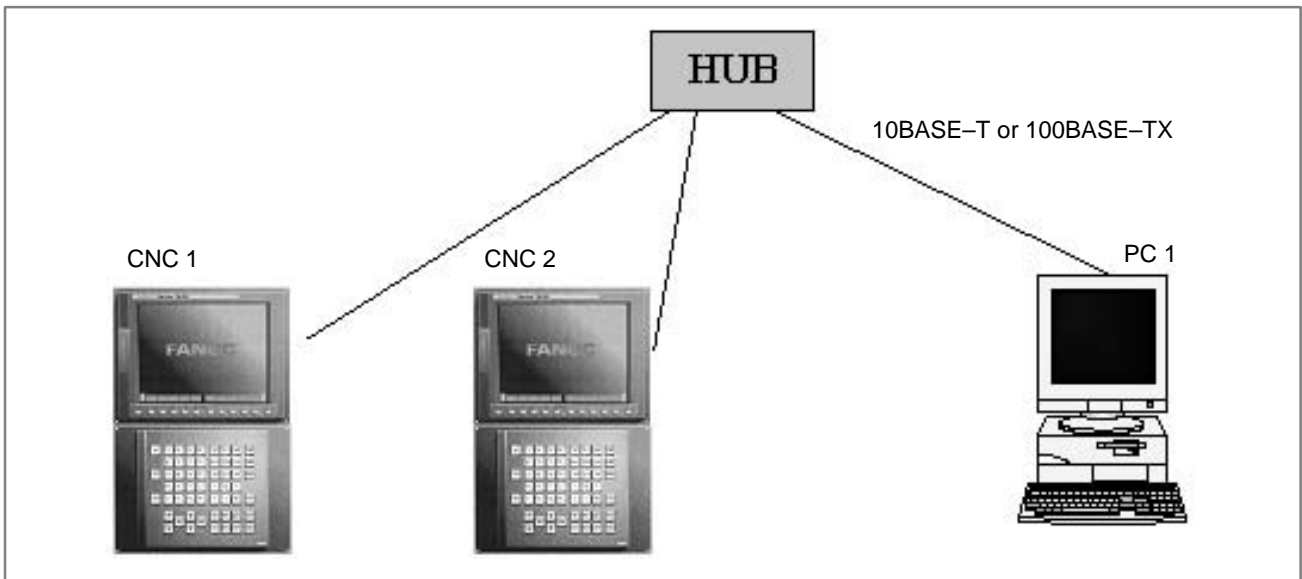

	CNC 1	CNC 2
IP address	192.168.1.1	192.168.1.2
Subnet mask	255.255.255.0	255.255.255.0
Router IP address	None	None
IP address	192.168.1.100	192.168.1.100
Port number	9000	9000
NC parameter No. 802	21	21
NC parameter No. 820	67 'C'	67 'C'
NC parameter No. 821	78 'N'	78 'N'
NC parameter No. 822	67 'C'	67 'C'
NC parameter No. 823	49 '1'	50 '2'

The Ethernet parameter screen is used for setting.

The parameter screen is used for setting.

	PC 1
IP address	192.168.0.100
Subnet mask	255.255.255.0
Default gateway	None
ocsnc	9000/TCP
ocscomm	9001/TCP
ocsapplication	9002/TCP

"Microsoft TCP/IP property" of the personal computer (Windows NT) is used for setting.

Refer to "FANUC FACTOLINK Script Function OPERATOR'S MANUAL (B-75054EN)".

17.3.1.5 Configuring a large network

When configuring a large network or expanding an existing network, consult with your network manager to set an IP address, subnet mask, and router IP address.

17.3.2 Parameter Setting of the FOCAS1/Ethernet Function

This subsection describes the settings required to operate the FOCAS1/Ethernet function (or DNC1/Ethernet function) when the embedded Ethernet function is used.

NOTE

With the series 20i-B, the "FOCAS1/Ethernet function" can communicate only with the following application software products. The function cannot communicate with any application software created by users using "FANUC Open CNC FOCAS1/Ethernet CNC/PMC Data Window Library."

- Servo Guide
- FANUC LADDER-III
- Machine Remote Diagnosis Package

17.3.2.1 Notes on using the FOCAS1/Ethernet function for the first time

CAUTION

When using the embedded Ethernet function for the first time, make various settings including IP address setting carefully and conduct a communication test sufficiently, consulting with your network manager.

Note that if an incorrect IP address is set, for example, the entire network can suffer from a communication error.

NOTE

- 1 The FOCAS1/Ethernet function allows up to five FOCAS1/Ethernet clients to be connected to one CNC.
- 2 If multiple application software products or multiple personal computers access the CNC simultaneously, the communication load on the CNC can increase, resulting in decreased communication speed and degraded CNC screen display processing.

17.3.2.2 FOCAS1/Ethernet parameter setting screen

On the Ethernet parameter setting screen, set the parameters for operating the FOCAS1/Ethernet function.

Display

Procedure

- 1 Place the CNC in the MDI mode.
- 2 Press the function key  .
- 3 Press the continuous menu key at the right end of the soft key display.
- 4 Press the [ETHPRM] soft key. The Ethernet parameter setting screen appears. The Ethernet functions currently available are displayed



The upper row displays the usable embedded Ethernet function device.

The embedded port or PCMCIA card is displayed.



The lower row displays the usable Ethernet option boards. When no option board is installed, no information is displayed.

- 5 By pressing the [EMBEDD] soft key, the parameters for the embedded Ethernet port can be set.
By pressing the [PCMCIA] soft key, the parameters for the PCMCIA Ethernet card can be set.

NOTE

The parameters for the embedded Ethernet port and the parameters for the PCMCIA Ethernet card are independent of each other.

- 6 By using the MDI keys and soft keys, enter and update data.

7 Switch the screen display with the page keys   .

If data is already registered, the data is displayed.

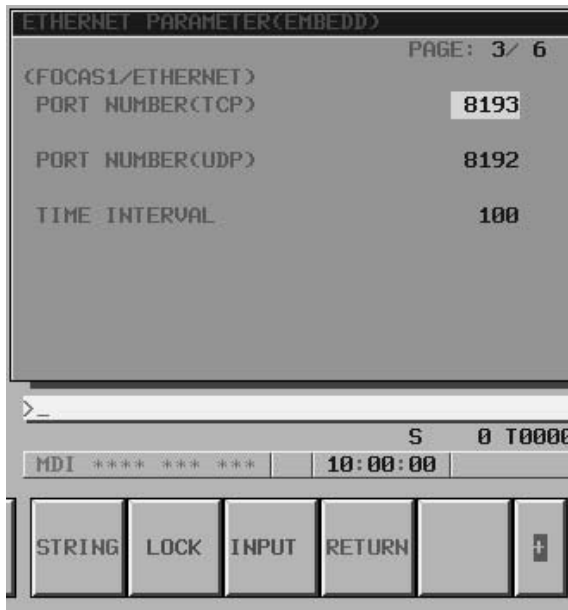
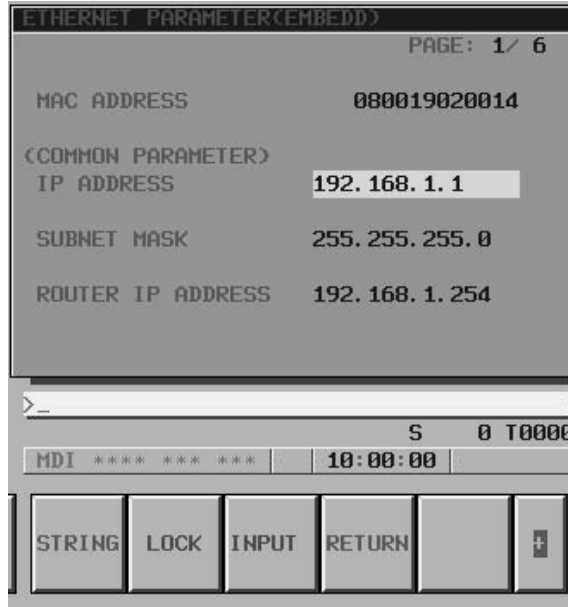

Display item and setting items

Display item related to the embedded Ethernet function

The item related to the embedded Ethernet function is displayed.

Item	Description
MAC ADDRESS	Embedded Ethernet MAC address

Embedded Ethernet TCP/IP setting items

Set the TCP/IP-related items of the embedded Ethernet.

Item	Description
IP ADDRESS	Specify the IP address of the embedded Ethernet. (Example of specification format: "192.168.1.1")
SUBNET MASK	Specify a mask address for the IP addresses of the network. (Example of specification format: "255.255.255.0")
ROUTER IP ADDRESS	Specify the IP address of the router. Specify this item when the network contains a router. (Example of specification format: "192.168.1.254")

FOCAS1/Ethernet setting items

Set the items related to the FOCAS1/Ethernet function.

Item	Description
PORT NUMBER (TCP)	Specify a port number to be used with the FOCAS1/Ethernet function. The valid input range is 5001 to 65535. When using a port number for the DNC1/Ethernet function, refer to "FANUC Personal Computer FA System Windows NT Version OPERATOR'S MANUAL (B-75044EN)".
PORT NUMBER (UDP)	Specify this item when using the DNC1/Ethernet function. Specify a UDP port number for transmitting UDP broadcast data. The valid input range is 5001 to 65535. For details, refer to "FANUC Personal Computer FA System Windows NT Version OPERATOR'S MANUAL (B-75044EN)". Set 0 when using the FOCAS1/Ethernet function or when transmitting no UDP broadcast data.
TIME INTERVAL (NOTE 1)	Specify this item when using the DNC1/Ethernet function. Specify a time interval at which UDP broadcast data specified above with a UDP port number is transmitted. The unit is 10 ms. The valid input range is 10 to 65535. This means that a value less than 100 ms cannot be specified. Set 0 when using the FOCAS1/Ethernet function or when transmitting no UDP broadcast data. Example) 100: Broadcast data is transmitted at intervals of one second [1000 ms] (= 100 × 10).

NOTE

- 1 When a small value is set for the item of time interval, communication load increases, and the performance of the network can be adversely affected.
- 2 The parameters for the PCMCIA Ethernet card are set to the following default values before shipment:

IP address:	192.168.1.1
Subnet mask:	255.255.255.0
Router IP address:	None
TCP port number:	8193
UDP port number:	0
Time interval:	0

**17.3.2.3
Using the
FOCAS1/Ethernet
function on a small
network**

An example of minimum setting required to operate the FOCAS1/Ethernet function on a small network is provided below. In this example, one personal computer is connected to two CNCs through FOCAS1/Ethernet.

- On Personal Computer 1, the client of the FOCAS1/Ethernet function operates.
- On CNC 1 and CNC 2, the server of the FOCAS1/Ethernet function operates

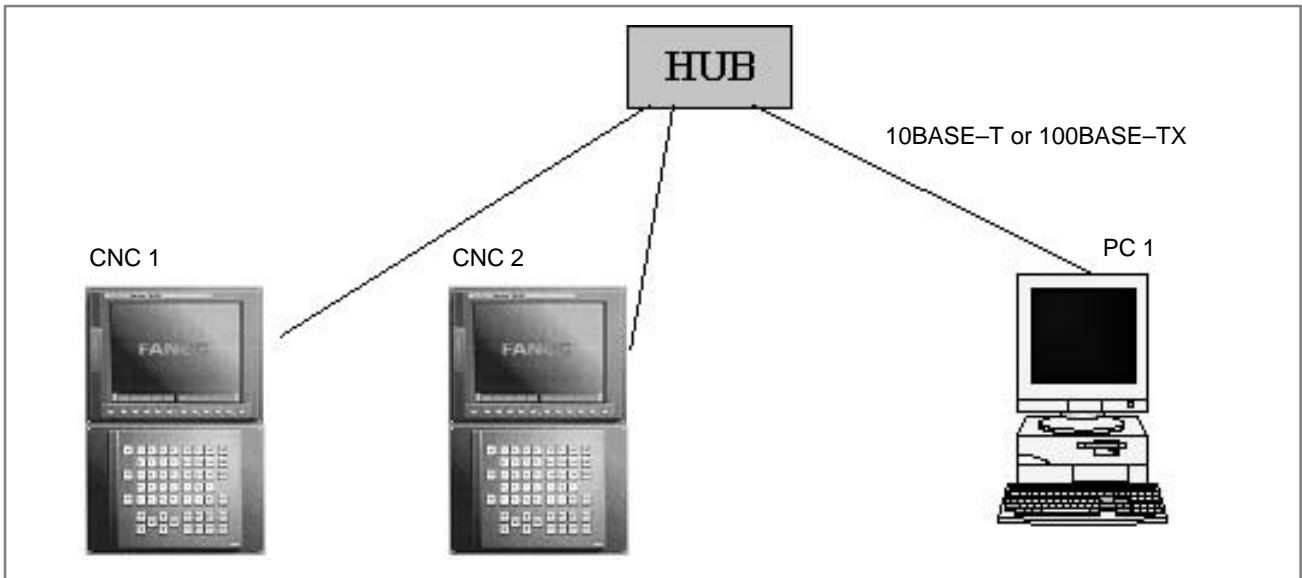

	CNC 1	CNC 2
IP address	192.168.1.1	192.168.1.2
Subnet mask	255.255.255.0	255.255.255.0
Router IP address	None	None
TCP port number	8193	8193
UDP port number	0	0
Time interval	0	0

The Ethernet parameter screen is used for setting.

		PC 1
IP address		192.168.1.101
Subnet mask		255.255.255.0
Default gateway		None
CNC 1	NC IP address	192.168.1.1
	NC TCP port number	8193
CNC 2	NC IP address	192.168.1.2
	NC TCP port number	8193

"Microsoft TCP/IP property" of the personal computer (Windows 95/98/NT/2000) is used for setting.

The arguments of the data window library function cnc_allclibhdl3 are used for setting.

17.3.2.4 Using the DNC1/Ethernet function on a small network

An example of minimum setting required to operate the DNC1/Ethernet function on a small network is provided below.

In this example, one personal computer is connected to two CNCs through DNC1/Ethernet.

- On Personal Computer 1, the client of the DNC1/Ethernet function operates.
- On CNC 1 and CNC 2, the server of the DNC1/Ethernet function operates.

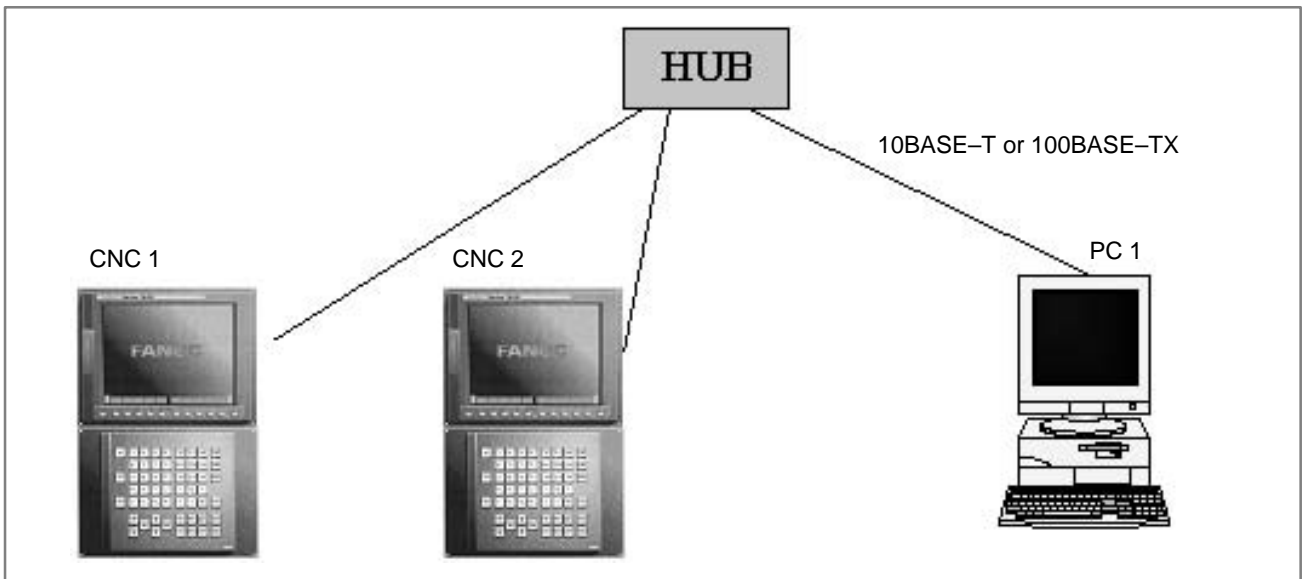

	CNC 1	CNC 2
IP address	192.168.1.1	192.168.1.2
Subnet mask	255.255.255.0	255.255.255.0
Router IP address	None	None
TCP port number	8193	8193
UDP port number	8192	8192
Time interval	100	100

The Ethernet parameter screen is used for setting.

		PC 1
IP address		192.168.1.101
Subnet mask		255.255.255.0
Default gateway		None
FANUC_C4_SERVER		8192/udp
CNC 1		Machine No. 1
	NC IP address	192.168.1.1
	NC TCP port number	8193
CNC 2		Machine No. 2
	NC IP address	192.168.1.2
	NC TCP port number	8193

"Microsoft TCP/IP property" of the personal computer (Windows NT) is used for setting.

Refer to "FANUC Personal Computer FA System Windows NT Version OPERATOR'S MANUAL".

17.3.2.5 Configuring a large network

When configuring a large network or expanding an existing network, consult with your network manager to set an IP address, subnet mask, and router IP address.

17.3.3 Parameter Setting of the FTP File Transfer Function

This subsection describes the settings required to operate the FTP file transfer function when the embedded Ethernet function is used.

17.3.3.1 Notes on using the FTP file transfer function for the first time

CAUTION

When using the embedded Ethernet function for the first time, make various settings including IP address setting carefully and conduct a communication test sufficiently, consulting with your network manager.

Note that if an incorrect IP address is set, for example, the entire network can suffer from a communication error.

NOTE

With the FTP file transfer function, only one FTP session can be established with one CNC.

17.3.3.2 FTP file transfer parameter setting screen

On the Ethernet parameter setting screen, set the parameters for operating the FTP file transfer function.

Display

Procedure

- 1 Place the CNC in the MDI mode.
- 2 Press the function key .
- 3 Press the continuous menu key at the right end of the soft key display.
- 4 Press the [ETHPRM] soft key. The Ethernet parameter setting screen appears. The Ethernet functions currently available are displayed.



The upper row displays the usable embedded Ethernet function device.

The embedded port or PCMCIA card is displayed.



The lower row displays the usable Ethernet option boards. When no option board is installed, no information is displayed.

- 5 By pressing the [EMBEDD] soft key, the parameters for the embedded Ethernet port can be set.
By pressing the [PCMCIA] soft key, the parameters for the PCMCIA Ethernet card can be set.

NOTE

The parameters for the embedded Ethernet port and the parameters for the PCMCIA Ethernet card are independent of each other.

- 6 By using the MDI keys and soft keys, enter and update data.

- 7 Switch the screen display with the page keys   .

If data is already registered, the data is displayed.

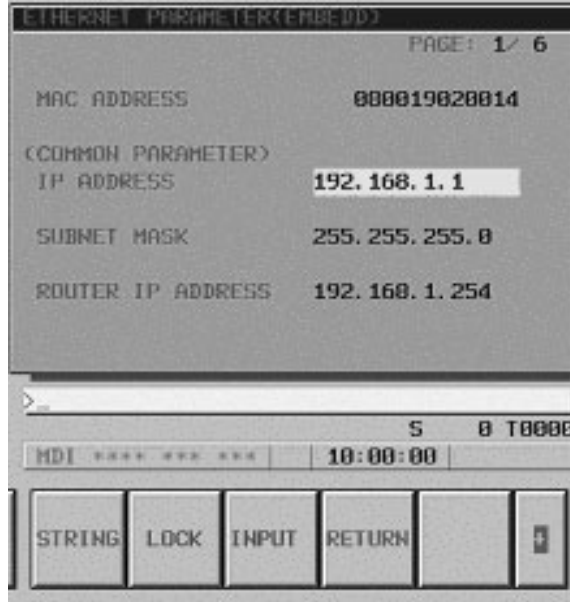

Display item and setting items

Display item related to the embedded Ethernet function

The item related to the embedded Ethernet function is displayed.

Item	Description
MAC ADDRESS	Embedded Ethernet MAC address

Embedded Ethernet TCP/IP setting items

Set the TCP/IP-related items of the embedded Ethernet.

Item	Description
IP ADDRESS	Specify the IP address of the embedded Ethernet. (Example of specification format: "192.168.1.1")
SUBNET MASK	Specify a mask address for the IP addresses of the network. (Example of specification format: "255.255.255.0")
ROUTER IP ADDRESS	Specify the IP address of the router. Specify this item when the network contains a router. (Example of specification format: "192.168.1.254")

FTP file transfer setting items

Make settings related to the FTP file transfer function.
Settings for up to three host computers can be made.

Item	Description
PORT NUMBER	Specify a port number to be used with the FTP file transfer function. An FTP session is used, so that "21" is to be specified usually.
IP ADDRESS	Specify the IP address of the host computer. (Example of specification format: "192.168.1.150")
USERNAME	Specify a user name to be used for logging in to the host computer with FTP. (Up to 31 characters can be specified.)
PASSWORD	Specify a password for the user name specified above. Be sure to set a password. (Up to 31 characters can be specified.)
LOGIN DIR	Specify a work directory to be used when logging in to the host computer. (Up to 127 characters can be specified.)

17.3.3.3 Parameters

The NC parameters related to the FTP file transfer function are described below.

Parameters

0020	I/O CHANNEL: Input/output device selection
------	--

[Data type] Byte

[Valid data range] 9: Select the embedded Ethernet as the input/output device.

0931	Special character (No. 1)
0932	Special character (No. 2)
0933	Special character (No. 3)
0934	Special character (No. 4)
0935	Special character (No. 5)

[Data type] Byte

[Valid data range] 32 to 126

NC parameters No. 931 to No. 935 enable soft keys to substitute for characters unavailable with the MDI keys.

When a number other than 0 is set in each of these parameters, [CHAR-1] to [CHAR-5] are displayed in the input soft keys for special characters.

Example) When 33 is set in parameter No. 931, pressing the [CHAR-1] soft key enters "!".

17.3.3.4 Using the FTP file transfer function on a small network

An example of minimum setting required to operate the FTP file transfer function on a small network is provided below. (Windows NT 4.0 Workstation is used as the OS for the personal computer.)

In this example, one personal computer is connected to two CNCs through the FTP file transfer function.

- On Personal Computer 1, the FTP server function operates.
- On CNC 1 and CNC 2, the FTP client operates as the FTP file transfer function.

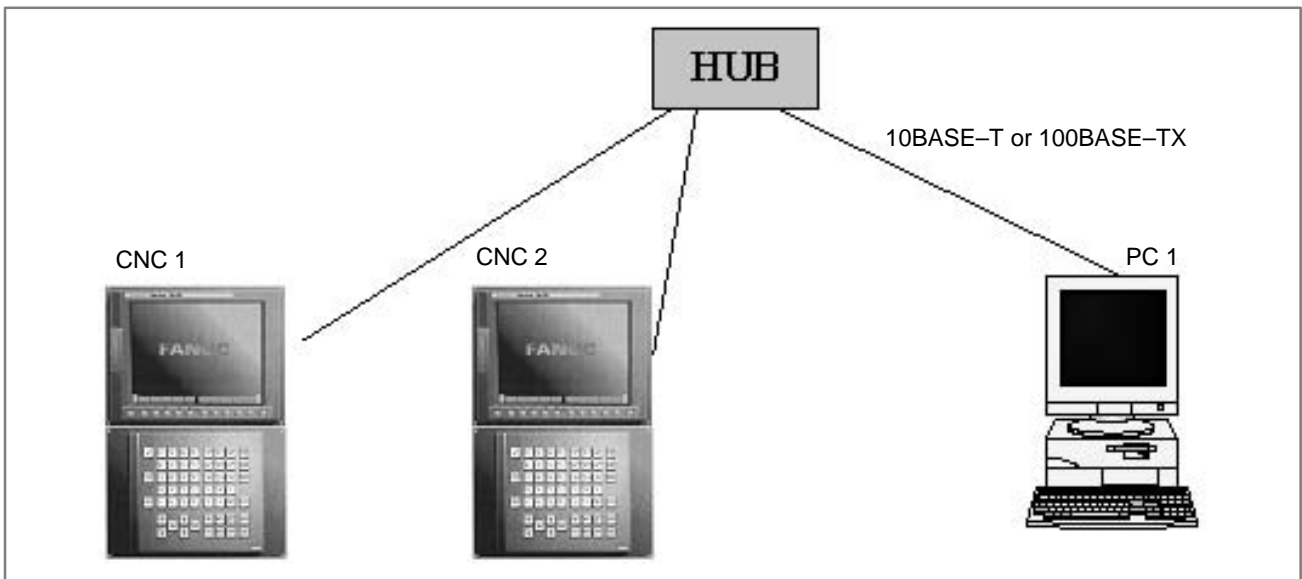

		CNC 1	CNC 2
IP address		192.168.1.1	192.168.1.2
Subnet mask		255.255.255.0	255.255.255.0
Router IP address		None	None
Connection host 1	Port number	21	21
	IP address	192.168.1.150	192.168.1.150
	User name	FANUC	FANUC
	Password	FANUC	FANUC
	Login DIR	None	None
NC parameter No. 20		9	9

The Ethernet parameter screen is used for setting.

The parameter screen is used for setting.

		PC 1
IP address		192.168.1.150
Subnet mask		255.255.255.0
Default gateway		None
User name		FANUC
Password		FANUC
Login DIR		Default

"Microsoft TCP/IP property" of the personal computer (Windows NT) is used for setting.

"User manager" of the personal computer (Windows NT) is used for setting.

"Internet service manager" of the personal computer (Windows NT) is used for setting.

17.3.3.5 Configuring a large network

When configuring a large network or expanding an existing network, consult with your network manager to set an IP address, subnet mask, and router IP address.

17.3.4 Communication Parameter Input Method

This subsection describes the method of parameter input when the embedded Ethernet function is used.

Basic method of data input

The basic method of data input is described below, using an example of IP address input.

Procedure

- 1 Place the CNC in the MDI mode.
- 2 Display the Ethernet parameter screen.
- 3 Move the cursor to a desired input item with cursor keys.
- 4 Type data with MDI keys.
- 5 Press the [INPUT] soft key or the function key  to enter the data.

NOTE

When deleting numeric data already set, enter 0. When deleting character data already set, enter SP (space).

Example) Setting 192.168.1.1 as IP address data

- (a) Move the cursor to the item of IP address.

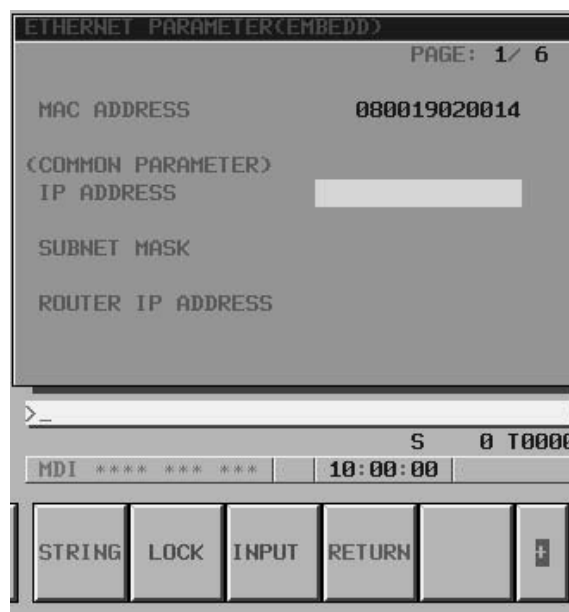

(b) Type 192.168.1.1 with the MDI keys.

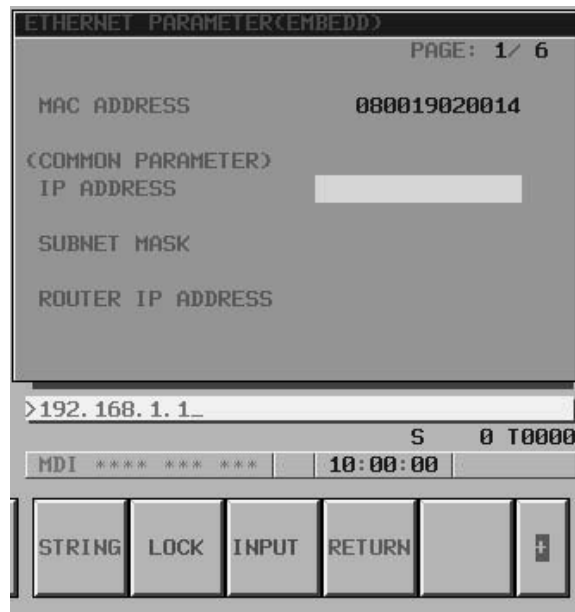

(c) Press the [INPUT] soft key or the function key to enter the data.

This stores the parameter in the nonvolatile memory of the CNC.



NOTE

Turn on the power again so that you should make a changed parameter effective.

Or, push soft key [RESET] on the maintenance screen of embedded Ethernet.

Method of lowercase character input

The method of entering lowercase characters when specifying a user name, password, and login DIR is described below.

Procedure

- 1 Place the CNC in the MDI mode.
- 2 Display the Ethernet parameter screen.
- 3 Move the cursor to a desired input item with cursor keys.
- 4 When the [UNLOCK] soft key is displayed, uppercase characters are actually entered through MDI keys. For lowercase character input, press the [UNLOCK] soft key. The soft key display changes from [UNLOCK] to [LOCK].
- 5 Then, press the MDI keys A through Z. All of these characters are entered as lowercase characters.



- 6 To enter uppercase characters, press the [LOCK] soft key.

Method of entering a long character string

The method of entering a character string longer than 32 characters for specifying a login DIR is described below.

As an example, the processing for setting the character string "/NCDATA/NCPROGRAM/LINE001/GROUP002" is described.

Procedure

- 1 Place the CNC in the MDI mode.
- 2 Display the Ethernet parameter screen.

- 3 Move the cursor to LOGIN DIR with cursor keys.



- 4 Press the [STRING] soft key. The cursor position and soft key display change as shown below.



- 5 Type `"/NCDATA/NCPROGRAM/LINE001/GROUP0"` with the MDI keys, then press the [INPUT] soft key.



- 6 Next, type the remaining character string `"02"` with the MDI keys, then press the [INPUT] soft key.

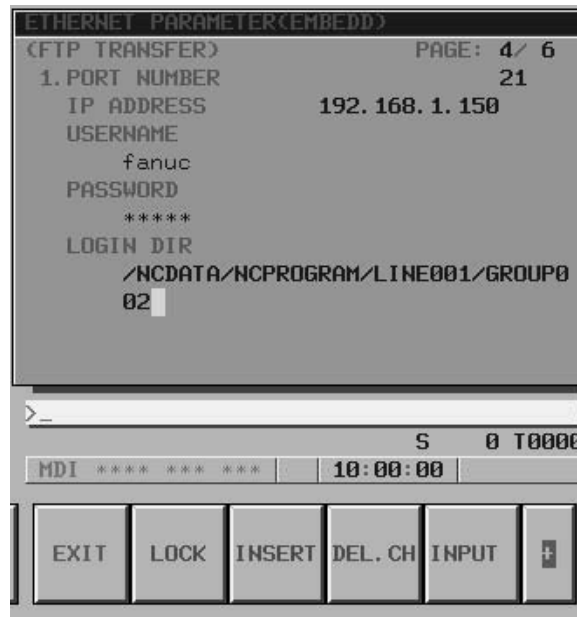

[Tip]

For example, even if the character string is divided into `"/NCDATA/NCPROGRAM"` and `"/LINE001/GROUP002"` for two input operations the same result can be obtained.

- 7 To insert "/FACTORY0010" between "NCPROGRAM" and "/LINE001", move the cursor to "/" prefixed to "LINE001" then type "/FACTORY0010" with the MDI keys. Finally, press the [INSERT] soft key.

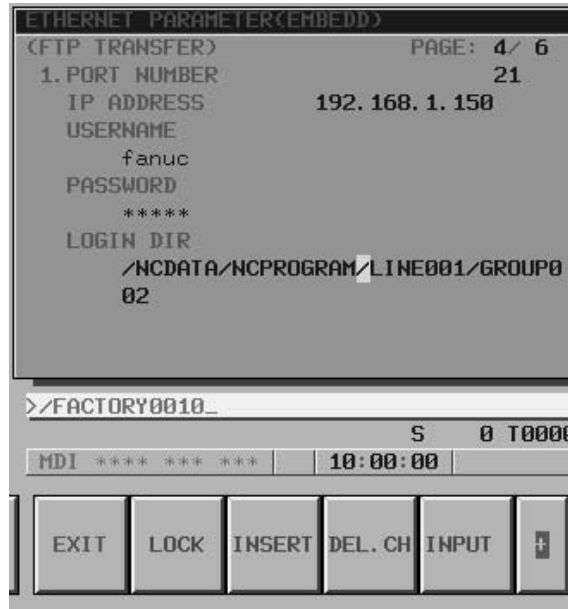

- 8 To delete a character, move the cursor to the character to be deleted, then press the [DEL.CH] soft key. This operation deletes a character on which the cursor is placed one at a time.
- 9 To overwrite a character, move the cursor to the character to be overwritten, then type a desired character with the MDI key. Finally, press the [INPUT] soft key. This operation overwrites a character on which the cursor is placed.
- 10 Upon completion of character string input, press the [RETURN] soft key. This operation returns the cursor position and soft key display to the state of step 1, and stores the set data in the nonvolatile memory of the CNC.

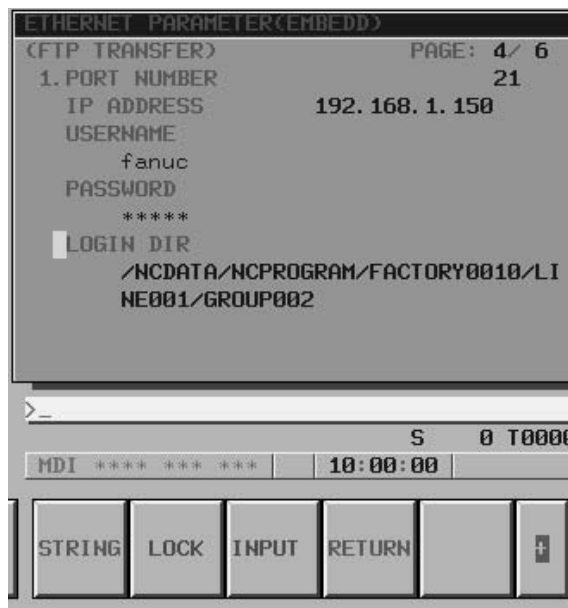

Method of entering special characters

The method of entering special characters such as ”\” unavailable with the MDI keys is described below.

As an example, the procedure for setting the character string ”PROG\$” is described.

Procedure

- 1 Place the CNC in the MDI mode.
- 2 Display the Ethernet parameter screen.
- 3 Move the cursor to LOGIN DIR with cursor keys.
- 4 Type ”PROG” with the MDI keys, then press the continuous menu key at the right end of the soft key display.



NOTE

Those characters unavailable with the MDI keys that are used frequently such as :, ¥, \$, and _ can be entered using soft keys. To enter a character other than these characters, set the ASCII code of the character in a parameter from parameters No. 931 through No. 935. For details, see Subsection 17.3.3.3, ”Parameters”.

5 Press the [\$\$\$] soft key.



6 Press the [INPUT] soft key.



17.4 SWITCHING BETWEEN THE EMBEDDED ETHERNET DEVICES

There are two types of embedded Ethernet devices: the embedded Ethernet port and PCMCIA Ethernet card.

Screen operation is required to switch between these two types of devices.

Procedure

- 1 Place the CNC in the MDI mode.
- 2 Press the function key  .
- 3 Press the continuous menu key at the right end of the soft key display.
- 4 Press the [ETHPRM] soft key. The Ethernet parameter setting screen appears. The Ethernet functions currently available are displayed.



The upper row displays the usable embedded Ethernet function device.

The embedded port or PCMCIA card is displayed.

The lower row displays the usable Ethernet option boards. When no option board is installed, no information is displayed.

- 5 Press the [SWITCH] soft key. The screen for switching between the embedded Ethernet port and the PCMCIA Ethernet card appears.



- 6 Press the [PCMCIA] soft key. A confirmation message appears. Press the [EXEC] soft key to switch the device.

NOTE

Information about the switched device is stored in the nonvolatile memory.

So, when you turn on the power next time, the previously selected device can be used directly.

17.5 EMBEDDED ETHERNET OPERATIONS

This section describes the operation required of each embedded Ethernet function.

17.5.1 FACTOLINK Function

The operation of the FACTOLINK function is described below.

Display

Procedure

- 1 Press the function key  .
- 2 Press the continuous menu key at the right end of the soft key display.



- 3 Press the [FALINK] soft key. The FACTOLINK screen appears. The screen shown below is a sample FACTOLINK screen.

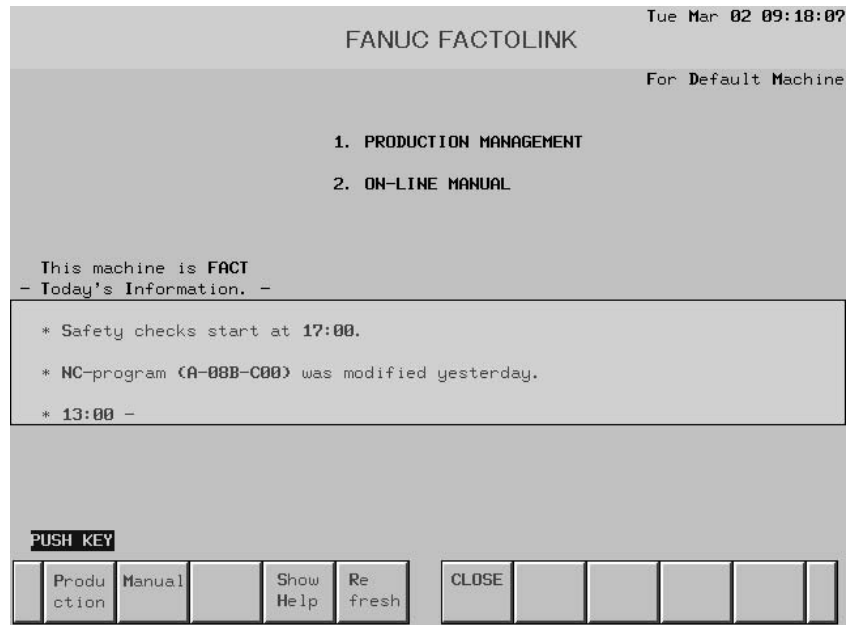

17.5.2 FTP File Transfer Function

The operation of the FTP file transfer function is described below.

17.5.2.1 Host file list display

A list of the files held on the hard disk embedded to the host computer is displayed.

Procedure

- 1 Press the function key  .
- 2 Press the continuous menu key at the right end of the soft key display.
- 3 Press the [HOST] soft key. The host file list screen appears. The Ethernet functions currently available are displayed.



The upper row displays the usable embedded Ethernet function device.

The embedded port or PCMCIA card is displayed.

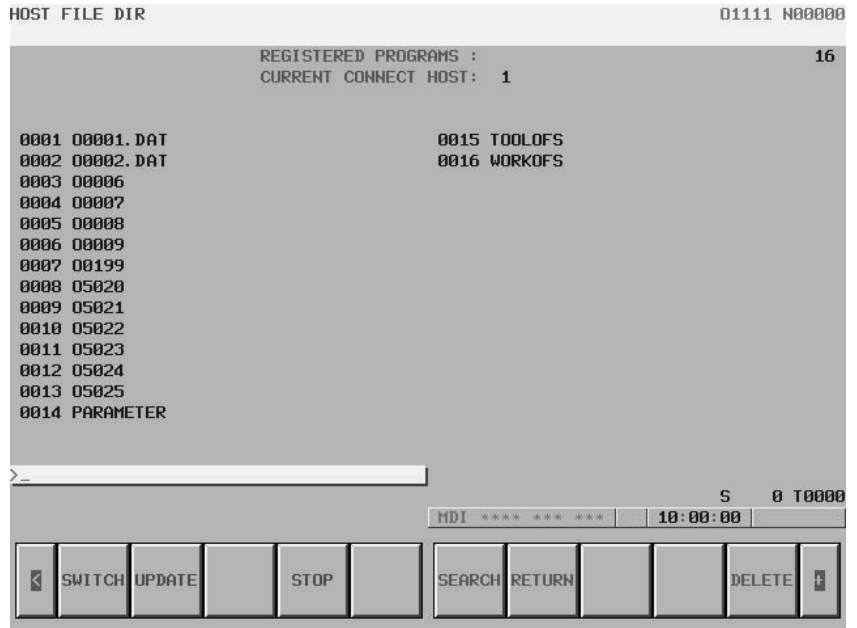

The lower row displays the usable Ethernet option boards. When no option board is installed, no information is displayed.

- 4 When you press the [EMBEDD] soft key, a list of the files held on the host computer specified with the embedded Ethernet port is displayed. If the usable embedded Ethernet function device is the PCMCIA card, the [PCMCIA] soft key is displayed instead of the [EMBEDD] soft key. When you press the [PCMCIA] soft key, a list of the files held on the host computer specified with the PCMCIA Ethernet card is displayed.



NOTE

Depending on the FTP server software, the number of displayed programs may differ between the host file list screen above and the host file list (detail) screen described below.

- 5 When a list of files is larger than one page, the screen display can be switched using the page keys  .
- 6 Press the [UPDATE] soft key to update the screen display.
- 7 Press the [SWITCH] soft key. The host file list (detail) screen appears.

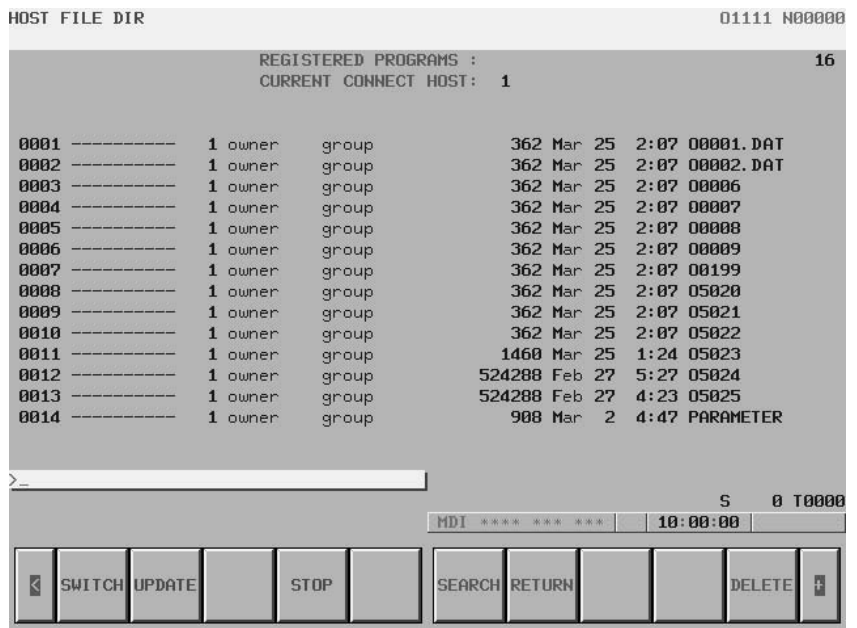

NOTE

The host file list (detail) screen shown above is an example of screen display, and information displayed may vary according to the specification of the FTP server used with the host computer.

Display items

- | | |
|--|--|
| <ul style="list-style-type: none"> ● Number of registered program files ● Currently connected host | <p>The number of files registered in the directory (folder) of the host computer currently connected is displayed.</p> <p>The number of the host currently connected is displayed.</p> |
|--|--|

List of operations

- | | |
|--|---|
| <ul style="list-style-type: none"> ● SWITCH ● UPDATE ● STOP ● SEARCH ● DELETE ● READ ● PUNCH | <p>This operation switches between normal display and detail display.</p> <p>This operation updates information displayed.</p> <p>This operation stops [SEARCH] operation.</p> <p>This operation updates screen information so that a file specified by its file number is placed at the start of the list.</p> <p>This operation deletes a file held on the hard disk embedded to the host computer.</p> <p>This operation reads a file held on the hard disk embedded to the host computer to the CNC part program storage. This soft key is displayed only when 9 is set as the input/output device number (parameter No.0020) of the CNC, and the CNC is placed in the EDIT mode.</p> <p>This operation outputs a file held in the CNC part program storage to the hard disk embedded to the host computer. This soft key is displayed only when 9 is set as the input/output device number (parameter No.0020) of the CNC, and the CNC is placed in the EDIT mode.</p> |
|--|---|

17.5.2.2 Host file search

When a list of the files held on the hard disk embedded to the host computer is displayed, a file can be placed at the start of the list by specifying its file number.

Procedure

- 1 Display the host file list screen.
- 2 Press the [SEARCH] soft key.
- 3 Type the file number of a file to be displayed at the start of the list with the MDI keys.
[Input format]
<file-number>
- 4 Press the [EXEC] soft key.
- 5 During search, "SEARCH" blinks in the lower-right corner of the screen.

17.5.2.3 Host file deletion

A file held on the hard disk embedded to the host computer can be deleted.

Procedure

- 1 Display the host file list screen.
- 2 Press the [DELETE] soft key.
- 3 Type the file number or file name of a file to be deleted, with the MDI keys.
[Input format]
<file-number>
or
<file-name>
- 4 Press the [EXEC] soft key.
- 5 During deletion, "DELETE" blinks in the lower-right corner of the screen.

NOTE

- 1 When a file number is used for deletion, only a file displayed on the host file list screen can be deleted.
- 2 The information displayed at the right end of the host file list (detail) screen is recognized as a file name. So, when deleting a host file from the host file list (detail) screen by specifying its file number, check that a file name is displayed at the right end of the screen, before specifying the file number.

17.5.2.4 NC program input

A file (NC program) on the host computer can be read to the CNC memory.

For the host file list screen

Procedure

- 1 Place the CNC in the EDIT mode.
- 2 Display the host file list screen.
- 3 Press the [READ] soft key.
- 4 Type the file number or file name of an NC program to be input, with the MDI keys.
[Input format]
<file-number>
or
<file-name>
- 5 Press the [EXEC] soft key.
- 6 During input, "INPUT" blinks in the lower-right corner of the screen.

CAUTION

- 1 If the CNC memory holds an NC program that has the same O number as that of an NC program to be input, the NC program in the CNC memory is overwritten when bit 2 of parameter No. 3201 is set to 1.
- 2 If an NC program is input when bit 0 of parameter No. 3201 is set to 1, all NC programs in the CNC memory are automatically deleted before NC program input.

[Example of use]

When a file with the file name O0001.DAT held on the hard disk embedded to the host computer is to be input to the CNC memory, enter O001.DAT. Note, however, that the O number input to the CNC memory depends on the O number described in the file named O0001.DAT.

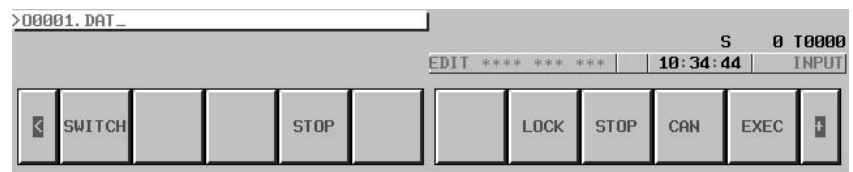

NOTE

When a file is input from this screen to the CNC memory, the O number described in the file is input.

For the program screen

Procedure

- 1 Place the CNC in the EDIT mode.
- 2 Press the function key  .
- 3 Press the continuous menu key at the right end of the soft key display.
- 4 Press the [PRGRM] soft key. The program screen appears.
- 5 Press the [(OPRT)] soft key.
- 6 Press the continuous menu key at the right end of the soft key display.
- 7 Press the [READ] soft key.
- 8 Type the O number of an NC program to be input, with the MDI keys.
[Input format]
<O-number>
- 9 Press the [EXEC] soft key.
- 10 During input, "INPUT" blinks in the lower-right corner of the screen.

CAUTION

- 1 If the CNC memory holds an NC program that has the same O number as that of an NC program to be input, the NC program in the CNC memory is overwritten when bit 2 of parameter No. 3201 is set to 1.
- 2 If an NC program is input when bit 0 of parameter No. 3201 is set to 1, all NC programs in the CNC memory are automatically deleted before NC program input.

NOTE

The valid O number of a file to be input to the hard disk embedded to the host computer is Oxxxx (with xxxx representing a number) only.

17.5.2.5 NC program output

A file (NC program) in the CNC memory can be output to the host computer.

For the host file list screen

Procedure

- 1 Place the CNC in the EDIT mode.
- 2 Display the host file list screen.
- 3 Press the [PUNCH] soft key.
- 4 Type the O number of an NC program to be output, with the MDI keys.
[Input format]
<O-number>

- 5 Press the [EXEC] soft key.
- 6 During output, "OUTPUT" blinks in the lower-right corner of the screen.

[Example of use]

When an NC program (O0001) in the CNC memory is to be output to the hard disk embedded to the host computer, enter O0001.

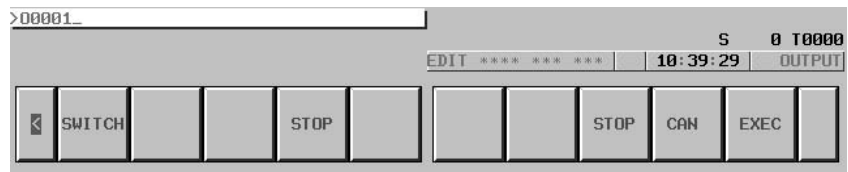

NOTE

An outputted file name is Oxxxx.

For the program screen

Procedure

- 1 Place the CNC in the EDIT mode.
- 2 Press the function key  .
- 3 Press the continuous menu key at the right end of the soft key display.
- 4 Press the [PRGRM] soft key. The program screen appears.
- 5 Press the [(OPRT)] soft key.
- 6 Press the continuous menu key at the right end of the soft key display.
- 7 Press the [PUNCH] soft key.
- 8 Type the O number of an NC program to be output, with the MDI keys.
[Input format]
<O-number>
- 9 Press the [EXEC] soft key.
- 10 During output, "OUTPUT" blinks in the lower-right corner of the screen.

NOTE

An outputted file name is Oxxxx.

17.5.2.6 Input/output of various types of data

With the FTP file transfer function, the types of data listed below can be input/output. This subsection describes the input/output method.

- A) NC parameter
- B) Tool offset value
- C) Custom macro variable
- D) Workpiece offset offset value
- E) Pitch error compensation data
- F) M code group
- G) Operation history data

Parameter input

The file (NC parameter) on the host computer can be input to the CNC memory.

Procedure

- 1 Place the CNC in the EDIT mode.
- 2 Press the function key  .
- 3 Press the continuous menu key at the right end of the soft key display.
- 4 Press the [PARAM] soft key. The parameter screen appears.
- 5 Press the [(OPRT)] soft key.
- 6 Press the continuous menu key at the right end of the soft key display.
- 7 Press the [READ] soft key.
- 8 Press the [EXEC] soft key.
- 9 During input, "INPUT" blinks in the lower-right corner of the screen.

File name

The fixed file name PRAMETER is used.

File format, restrictions

Refer to the operator's manual of each CNC.

Parameter output

The file (NC parameter) in the CNC memory can be output to the host computer.

Procedure

- 1 Place the CNC in the EDIT mode.
- 2 Press the function key  .
- 3 Press the continuous menu key at the right end of the soft key display.
- 4 Press the [PARAM] soft key. The parameter screen appears.
- 5 Press the [(OPRT)] soft key.
- 6 Press the continuous menu key at the right end of the soft key display.
- 7 Press the [PUNCH] soft key.

- 8 Press the [EXEC] soft key.
- 9 During output, "OUTPUT" blinks in the lower-right corner of the screen.

File name The fixed file name PRAMETER is used.

File format, restrictions Refer to the operator's manual of each CNC.

Tool offset value input

The file (tool offset value) on the host computer can be input to the CNC memory.

Procedure

- 1 Place the CNC in the EDIT mode.
- 2 Press the function key  .
- 3 Press the continuous menu key at the right end of the soft key display.
- 4 Press the [OFFSET] soft key. The tool compensation screen appears.
- 5 Press the [(OPRT)] soft key.
- 6 Press the continuous menu key at the right end of the soft key display.
- 7 Press the [READ] soft key.
- 8 Press the [EXEC] soft key.
- 9 During input, "INPUT" blinks in the lower-right corner of the screen.

File name The fixed file name TOOLOFS is used.

File format, restrictions Refer to the operator's manual of each CNC.

Tool offset value output

The file (tool offset value) in the CNC memory can be output to the host computer.

Procedure

- 1 Place the CNC in the EDIT mode.
- 2 Press the function key  .
- 3 Press the continuous menu key at the right end of the soft key display.
- 4 Press the [OFFSET] soft key. The tool compensation screen appears.
- 5 Press the [(OPRT)] soft key.
- 6 Press the continuous menu key at the right end of the soft key display.
- 7 Press the [PUNCH] soft key.
- 8 Press the [EXEC] soft key.
- 9 During output, "OUTPUT" blinks in the lower-right corner of the screen.

File name The fixed file name TOOLOFS is used.

File format, restrictions Refer to the operator's manual of each CNC.

Workpiece origin offset value input

The file (workpiece origin offset value) on the host computer can be input to the CNC memory.

Procedure

- 1 Place the CNC in the EDIT mode.
- 2 Press the function key  .
- 3 Press the continuous menu key at the right end of the soft key display.
- 4 Press the [WORK] soft key. The workpiece coordinate system setting screen appears.
- 5 Press the [(OPRT)] soft key.
- 6 Press the continuous menu key at the right end of the soft key display.
- 7 Press the [READ] soft key.
- 8 Press the [EXEC] soft key.
- 9 During input, "INPUT" blinks in the lower-right corner of the screen.

File name The fixed file name WORKOFS is used.

File format, restrictions Refer to the operator's manual of each CNC.

Workpiece origin offset value output

The file (workpiece origin offset value) in the CNC memory can be output to the host computer.

Procedure

- 1 Place the CNC in the EDIT mode.
- 2 Press the function key  .
- 3 Press the continuous menu key at the right end of the soft key display.
- 4 Press the [WORK] soft key. The workpiece coordinate system setting screen appears.
- 5 Press the [(OPRT)] soft key.
- 6 Press the continuous menu key at the right end of the soft key display.
- 7 Press the [PUNCH] soft key.
- 8 Press the [EXEC] soft key.
- 9 During output, "OUTPUT" blinks in the lower-right corner of the screen.

File name The fixed file name WORKOFS is used.

File format, restrictions Refer to the operator's manual of each CNC.

Pitch error compensation input

The file (pitch error compensation) on the host computer can be input to the CNC memory.

Procedure

- 1 Place the CNC in the EDIT mode.
- 2 Press the function key  .
- 3 Press the continuous menu key at the right end of the soft key display.
- 4 Press the [PITCH] soft key. The pitch error setting screen appears.
- 5 Press the [(OPRT)] soft key.
- 6 Press the continuous menu key at the right end of the soft key display.
- 7 Press the [READ] soft key.
- 8 Press the [EXEC] soft key.
- 9 During input, "INPUT" blinks in the lower-right corner of the screen.

File name

The fixed file name PITCH is used.

File format, restrictions

Refer to the operator's manual of each CNC.

Pitch error compensation output

The file (pitch error compensation) in the CNC memory can be output to the host computer.

Procedure

- 1 Place the CNC in the EDIT mode.
- 2 Press the function key  .
- 3 Press the continuous menu key at the right end of the soft key display.
- 4 Press the [PITCH] soft key. The pitch error setting screen appears.
- 5 Press the [(OPRT)] soft key.
- 6 Press the continuous menu key at the right end of the soft key display.
- 7 Press the [PUNCH] soft key.
- 8 Press the [EXEC] soft key.
- 9 During output, "OUTPUT" blinks in the lower-right corner of the screen.

File name

The fixed file name PITCH is used.

File format, restrictions

Refer to the operator's manual of each CNC.

M code group input

The file (M code group) on the host computer can be input to the CNC memory.

Procedure

- 1 Place the CNC in the EDIT mode.
- 2 Press the function key  .
- 3 Press the continuous menu key at the right end of the soft key display.
- 4 Press the [M-CODE] soft key. The M code group setting screen appears.
- 5 Press the [(OPRT)] soft key.
- 6 Press the continuous menu key at the right end of the soft key display.
- 7 Press the [READ] soft key.
- 8 Press the [EXEC] soft key.
- 9 During input, "INPUT" blinks in the lower-right corner of the screen.

File name

The fixed file name M-CODE is used.

File format, restrictions

Refer to the operator's manual of each CNC.

M code group output

The file (M code group) in the CNC memory can be output to the host computer.

Procedure

- 1 Place the CNC in the EDIT mode.
- 2 Press the function key  .
- 3 Press the continuous menu key at the right end of the soft key display.
- 4 Press the [M-CODE] soft key. The M code group setting screen appears.
- 5 Press the [(OPRT)] soft key.
- 6 Press the continuous menu key at the right end of the soft key display.
- 7 Press the [PUNCH] soft key.
- 8 Press the [EXEC] soft key.
- 9 During output, "OUTPUT" blinks in the lower-right corner of the screen.

File name

The fixed file name M-CODE is used.

File format, restrictions

Refer to the operator's manual of each CNC.

Operation history data input

The file (operation history data) on the host computer can be input to the CNC memory.

Procedure

- 1 Place the CNC in the EDIT mode.
- 2 Press the function key  .
- 3 Press the continuous menu key at the right end of the soft key display.
- 4 Press the [OPEHIS] soft key. The operation history screen appears.
- 5 Press the [(OPRT)] soft key.
- 6 Press the continuous menu key at the right end of the soft key display.
- 7 Press the [READ] soft key.
- 8 Press the [EXEC] soft key.
- 9 During input, "INPUT" blinks in the lower-right corner of the screen.

File name

The fixed file name HISTORY is used.

File format, restrictions

Refer to the operator's manual of each CNC.

Operation history data output

The file (operation history data) in the CNC memory can be output to the host computer.

Procedure

- 1 Place the CNC in the EDIT mode.
- 2 Press the function key  .
- 3 Press the continuous menu key at the right end of the soft key display.
- 4 Press the [OPEHIS] soft key. The operation history screen appears.
- 5 Press the [(OPRT)] soft key.
- 6 Press the continuous menu key at the right end of the soft key display.
- 7 Press the [PUNCH] soft key.
- 8 Press the [EXEC] soft key.
- 9 During output, "OUTPUT" blinks in the lower-right corner of the screen.

File name

The fixed file name HISTORY is used.

File format, restrictions

Refer to the operator's manual of each CNC.

17.5.2.7 Checking and changing of the connection host

Procedure

The host computer to which the FTP file transfer function attempts to make a connection as the current communication destination can be checked.

- 1 Press the function key  .
- 2 Press the continuous menu key at the right end of the soft key display.
- 3 Press the [CONNECT] soft key. The connection host change screen appears. The Ethernet functions currently available are displayed.



The upper row displays the usable embedded Ethernet function device.

The embedded port or PCMCIA card is displayed.

The lower row displays the usable Ethernet option boards. When no option board is installed, no information is displayed.

- 4 When you press the [EMBEDD] soft key, a list of the connection host computers specified with the embedded Ethernet port is displayed. If the usable embedded Ethernet function device is the PCMCIA card, the [PCMCIA] soft key is displayed instead of the [EMBEDD] soft key. When you press the [PCMCIA] soft key, a list of the connection host computers specified with the PCMCIA Ethernet card is displayed.

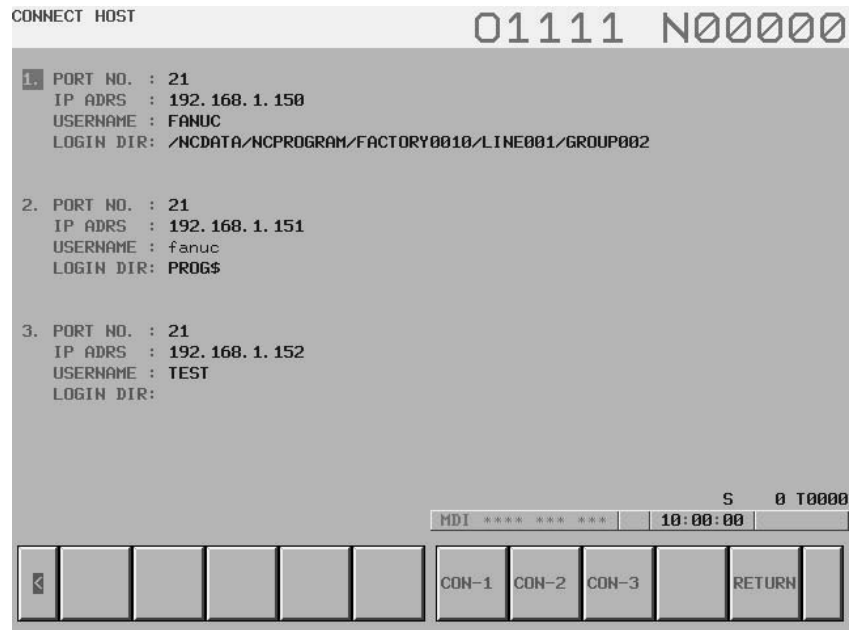
**NOTE**

The title of the host computer that is the current communication destination of the embedded Ethernet is displayed in reverse video.

- 5 The connected host can be changed by pressing the [CON-1], [CON-2], or [CON-3] soft key.

Display items

- **Port number, IP address, user name, login DIR** Those values that are set on the Ethernet parameter setting screen are displayed.

List of operations

- **CON-1** This operation changes the connected host to host 1.
- **CON-2** This operation changes the connected host to host 2.
- **CON-3** This operation changes the connected host to host 3.

17.6 EMBEDDED ETHERNET ERROR MESSAGE SCREEN

If an error occurs with each function of the embedded Ethernet function, the error message screen for the embedded Ethernet function displays an error message.

Display

Procedure

- 1 Press the function key  .
- 2 Press the continuous menu key at the right end of the soft key display.
- 3 Press the [ETHLOG] soft key. The Ethernet log screen appears. The Ethernet functions currently available are displayed.





The upper row displays the usable embedded Ethernet function device.

The embedded port or PCMCIA card is displayed.

The lower row displays the usable Ethernet option boards. When no option board is installed, no information is displayed.

- 4 By pressing the [EMBEDD] soft key or the [PCMCIA] soft key, the error message screen for the embedded Ethernet function can be displayed.
The error message screen does not differ between the embedded Ethernet port and PCMCIA Ethernet card. The same screen is shared.

- 5 Switch the screen display with the page keys  .



[Tip]

The latest error message is displayed at the top of the screen. To the right of an error message, the date and time data of the occurrence of the error is displayed. The format of date and time data is ddhmmss where dd represents a day, hh represents hours, mm represents minutes, and ss represents seconds.

Configuration

The embedded Ethernet log screen consists of the screens below.

- (1) EMB_ETH MASTER CTRL LOG screen (2 screens)
Log screen used to set the parameters of the embedded Ethernet function and display error messages at the time of embedded Ethernet initialization
- (2) EMB_ETH FOCAS1/ETHER LOG screen (2 screens)
Log screen used to display error messages related to the FOCAS1/Ethernet function (DNC1/Ethernet function)
- (3) EMB_ETH PMC LOG screen (2 screens)
Log screen used to display error messages related to the PMC online monitor functions such as FANUC LADDER-III
- (4) EMB_ETH FACTOLINK LOG screen (2 screens)
Log screen used to display error messages related to the FACTOLINK function
- (5) EMB_ETH FTP TRANSFER LOG screen (2 screens)
Log screen used to display error messages related to the FTP file transfer function

17.7 EMBEDDED ETHERNET MAINTENANCE SCREEN

With the embedded Ethernet function, a dedicated maintenance screen is available.

The maintenance screen enables operations to be checked when the embedded Ethernet function operates abnormally.

Display

Procedure

- 1 Press the function key  .
- 2 Press the continuous menu key at the right end of the soft key display.
- 3 Press the [ETHMNT] soft key. The Ethernet maintenance screen appears. The Ethernet functions currently available are displayed.





The upper row displays the usable embedded Ethernet function device.

The embedded port or PCMCIA card is displayed.

The lower row displays the usable Ethernet option boards. When no option board is installed, no information is displayed.

- 4 By pressing the [EMBEDD] soft key or the [PCMCIA] soft key, the maintenance screen for the embedded Ethernet function can be displayed.

The maintenance screen does not differ between the embedded Ethernet port and PCMCIA Ethernet card. The same screen is shared.

- 5 Switch the screen display with the page keys   .

- 6 The screen below is used to check the state of the communication cable and whether a communication destination exists. Enter the IP address of a communication destination through MDI keys, then press the [PING] soft key. Communication is performed three times with the specified communication destination, and the results are displayed.

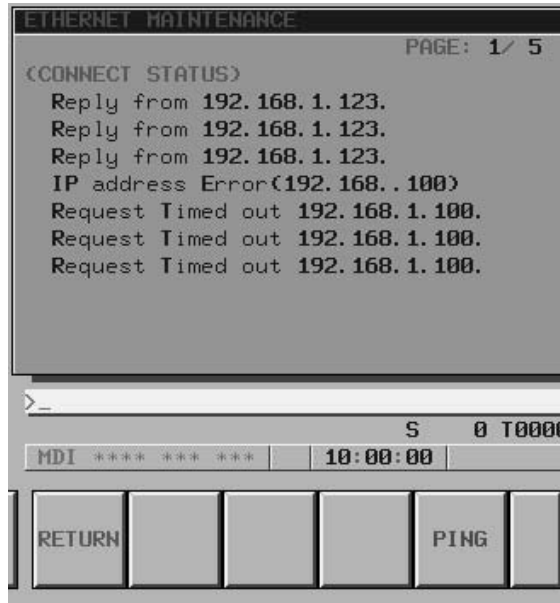

Messages displayed:

Reply from IP-address

This message indicates that a response was received from the specified communication destination and that the specified communication destination exists on the network.

Request Timed out IP-address

This message indicates that no response was received from the specified communication destination and that the specified communication destination does not exist on the network.

Check if the power to the communication destination equipment is turned on. Check also the parameter settings and network installation for errors.

IP address Error (IP-address)

The specified IP address is incorrect. Check the entered IP address.

- 7 The screen below is used to check the communication state of the embedded Ethernet function and the error detection count of the Ethernet controller.

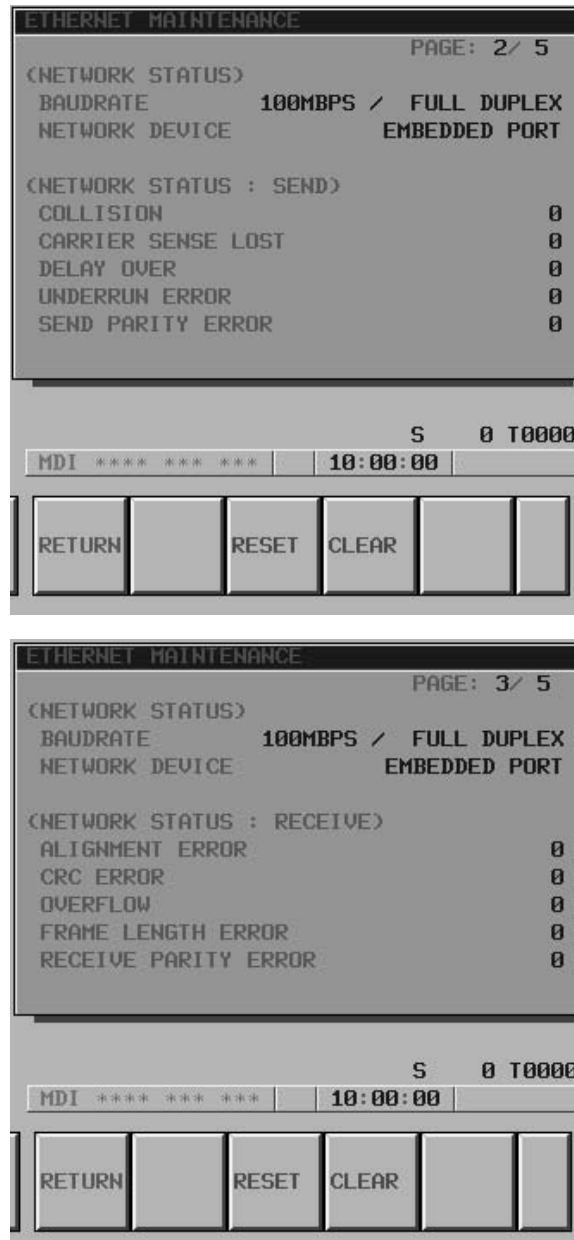

The screen consists of two pages: one page for an error detection count for transmission, and the other for an error detection count for reception.

By pressing the [CLEAR] soft key, the error detection counters for transmission and reception can be cleared to 0.

By pressing the [RESET] soft key, the current communication device can be initialized and communication can be performed from the initial state. Use this key to reset communication based on the embedded Ethernet function.

8 The screen below is used to check the state of each task of the embedded Ethernet function.

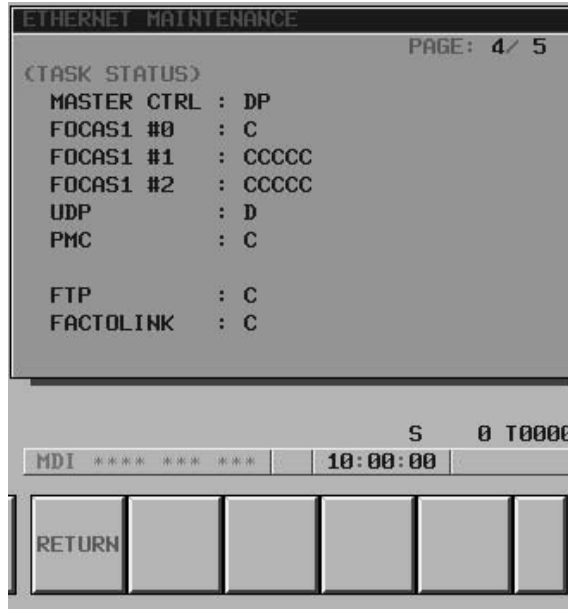

	Symbol	Meaning
MASTER CTRL	E	Ethernet controller being initialized
	D	Data being processed(NOTE)
	W	Waiting for data processing(NOTE)
	P	Waiting for parameter setting
	S	Parameters being set
FOCAS1 #0	X	Waiting for completion of Ethernet controller initialization
	E	Being activated
	C	Waiting for connection from the personal computer
	O	Connection being processed
	N	FOCAS1/Ethernet execution disabled
FOCAS1 #1,#2	X	Waiting for completion of Ethernet controller initialization
	C	Waiting for connection from the personal computer
	D	Data being processed(NOTE)
	W	Waiting for data processing(NOTE)
UDP	X	Not executed yet. Waiting for completion of Ethernet controller initialization.
	E	Being activated
	D	Data being processed(NOTE)
	W	Waiting for data processing(NOTE)

	Symbol	Meaning
PMC	X	Waiting for completion of Ethernet controller initialization
	D	Data being processed(NOTE)
	W	Waiting for data processing(NOTE)
FTP	X	Waiting for completion of Ethernet controller initialization
	D	Data being processed(NOTE)
	W	Waiting for data processing(NOTE)
FACTOLINK	X	Waiting for completion of Ethernet controller initialization
	D	Data being processed(NOTE)
	W	Waiting for data processing(NOTE)
REMOTE DIAG	X	Waiting for completion of Ethernet controller initialization
	P	Waiting for connection of machine remote diagnosis
	K	Machine remote diagnosis being connected

NOTE

A state change occurs between the states "Data being processed" and "Waiting for data processing" even when communication is not performed actually.

- 9 Information about the interface between the FTP file transfer function and CNC is displayed.



Item	Description
EMPTY COUNTER	Indicates a buffer empty count during NC program transfer from the FTP file transfer function to the CNC. This counter is initialized to 0 at power-on, then is incremented each time a certain condition is satisfied.
TOTAL SIZE	Indicates the total number of bytes transferred when one NC program is transferred using the FTP file transfer function.
READ POINTER WRITE POINTER	Indicates internal buffer management information when the FTP file transfer function is used.

17.8 DHCP/DNS FUNCTIONS

17.8.1 Overview

This additional manual explains DHCP and DNS functions of Embedded Ethernet .

By using DHCP function, CNC can get TCP/IP parameters from the DHCP server software of a PC .

(If DHCP function is not available, TCP/IP parameters need to be configured to CNC screen by manual.)

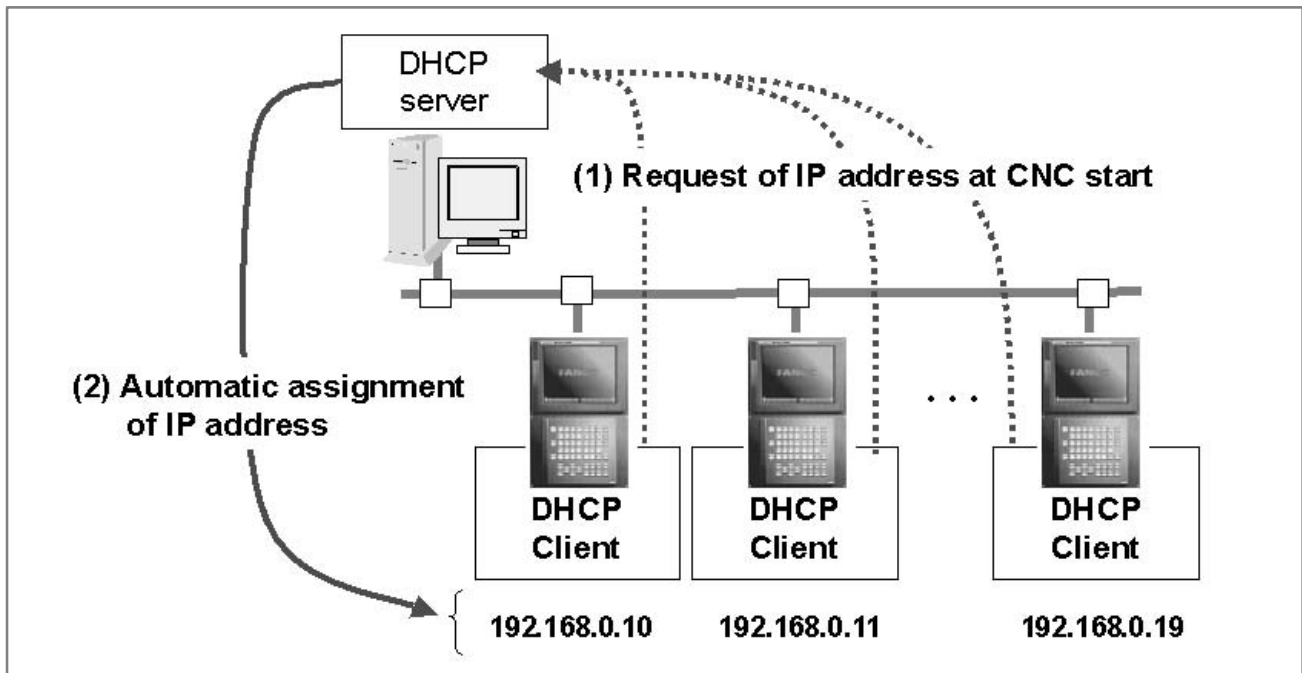

The following parameters can be configured from the DHCP server software of a PC.

- IP address
- Sub-net mask
- IP address for router
- IP address for DNS server
- Domain

(Note) DHCP : Dynamic Host Configuration Protocol

DNS : Domain Name System

By using DNS function, CNC can utilize a domain name (FQDN : fully qualified domain name, for example, www.fanuc.co.jp) in order to specify the remote communication partner, instead of an IP address.

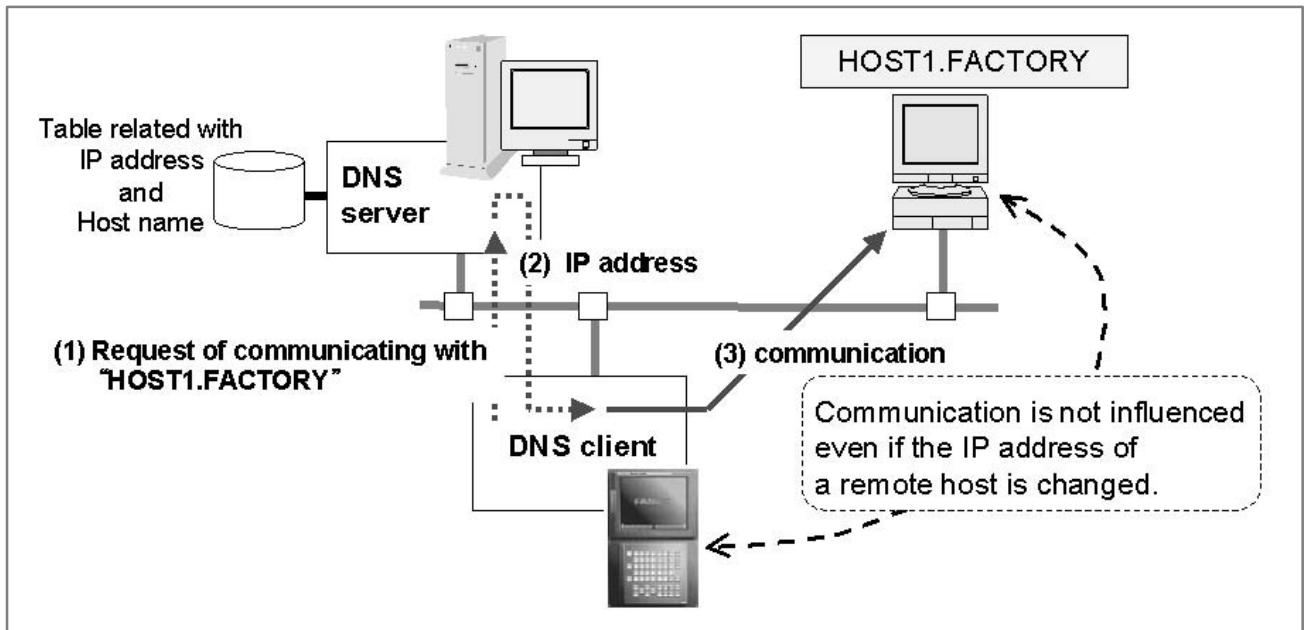

17.8.2 Settings

17.8.2.1 Parameters

For Standard Ethernet I/F

	#7	#6	#5	#4	#3	#2	#1	#0
14880		DHCP	DNS		D1ET			

[Data type] Bits

D1ET TCP, UDP and Time interval parameters, when DHCP is available.

0: The following parameters are configured automatically for FOCAS1/Ethernet function.

TCP port number	8193
UDPport number	0
Time interval	0

1: The following parameters are configured automatically for DNC1/Ethernet function.

TCP port number	8193
UDPport number	8192
Time interval	50

DNS 0: Not available

1: Available

DHCP 0: Not available

1: Available

Please reboot a CNC after re-configuring the above parameters.

(Or, please push Softkey [RESET] of Embedded Ethernet maintenance screen)

For PCMCIA LAN card

	#7	#6	#5	#4	#3	#2	#1	#0
14881		DHCP	DNS		D1ET			

17.8.2.2 Ethernet parameter screen

(1) Setting screen in the case that DHCP is available

When DHCP function works in normal, the following parameters are configured to CNC by the DHCP server of PC.

- IP address
- Sub-net mask
- IP address for router
- IP address for DNS server
- Host name
- Domain

In the case that the parameters are configured successfully



(Example of case that the default host name is configured.)



NOTE

A host name can be configured freely by using Ethernet parameter screen of CNC.
If its parameter item is empty, the host name "NC-"<MAC address> is used as default.
(Example: "NC-080019123456")

In the case that the parameters can not be configured by DHCP server

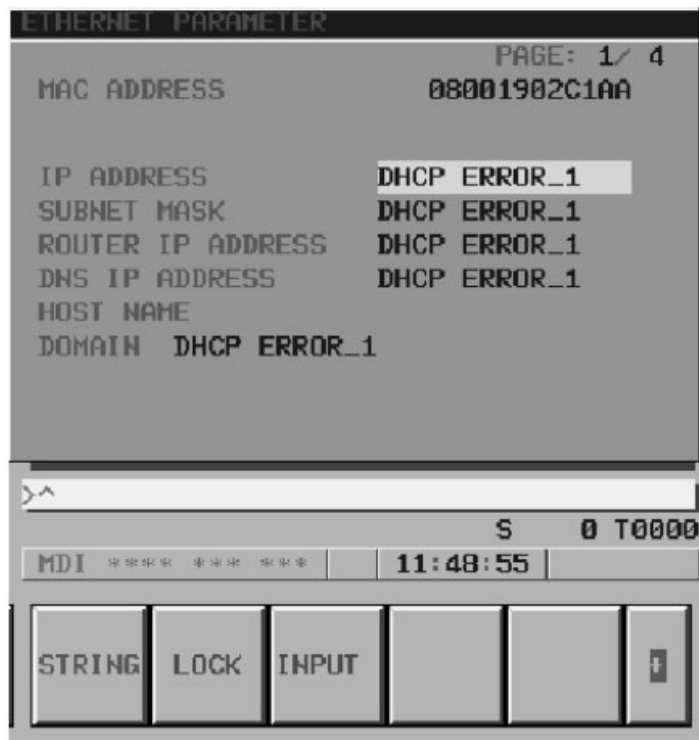

(2) Setting screen in the case that DNS is available

When DNS function is available, please set the "DNS IP address" for a remote DNS server.

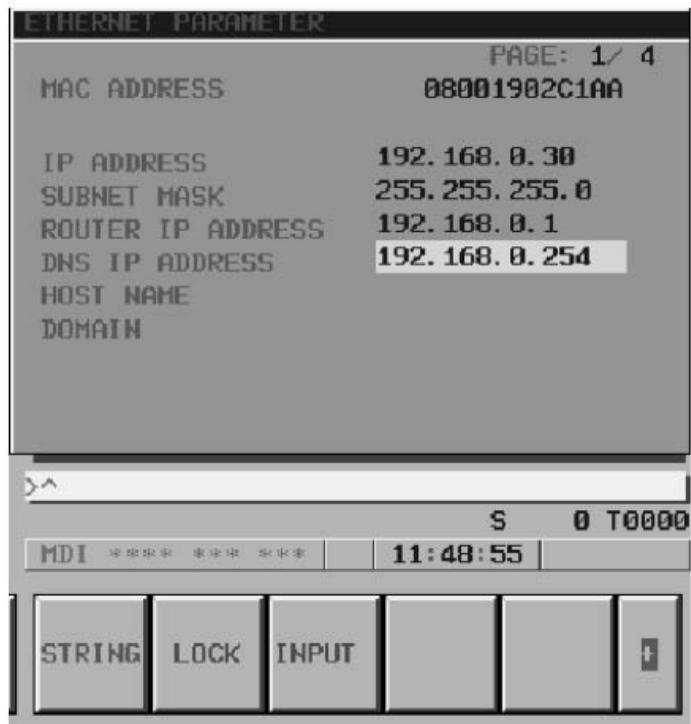

17.8.3 Application functions which can use DHCP/DNS

17.8.3.1 Applications which can utilize DHCP function

- FOCAS1/Ethernet (DNC1/Ethernet) function (Note)
 - Machine remote diagnosis function
 - FACTOLINK function
-

17.8.3.2 Application which can utilize DNS function

- FOCAS1/Ethernet (DNC1/Ethernet) function (Note)
- Machine remote diagnosis function

NOTE

When using FOCAS1/Ethernet function, DNS function of CNC need not be used. But, as described in "5. Application of DHCP and DNS to FOCAS1/ Ethernet function", a FOCAS1/Ethernet application software of PC refers to DNS server.

As for detail, please refer to "17.8.5. Application of DHCP and DNS to FOCAS1/Ethernet function".

17.8.4 Example of settings

On the condition of the following, this chapter explains the settings of DHCP/DNS server.

- 1) DHCP server and DNS server run on the same PC.
- 2) The IP address of DHCP/DNS server is "192.168.0.254".
- 3) The range of IP addresses leased by DHCP server is "192.168.0.10 to 192.168.0.29".
- 4) Domain name managed by DNS server is "factory".
- 5) There are DHCP/DNS server, CNCs and PC on the same domain "factory".

Example of system structure

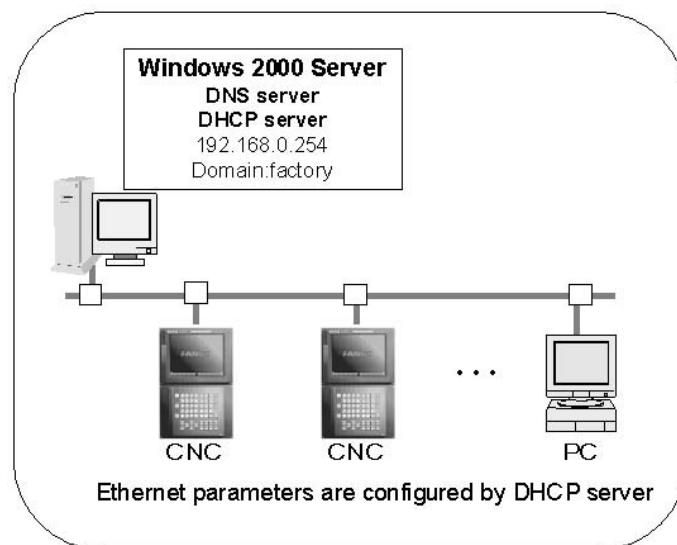

The procedures of DHCP and DNS settings are explained on next pages.

NOTE

The explanation of this chapter is an example. Please consult your factory's network administrator when applying the DHCP/DNS functions to your factory network actually.

17.8.4.1 Example of DHCP server settings on Windows2000 server

This section explains the procedure of DHCP server settings.

(1) Start of Microsoft management console (DHCP)

Click [Programs]–[Administrative Tools]–[DHCP].

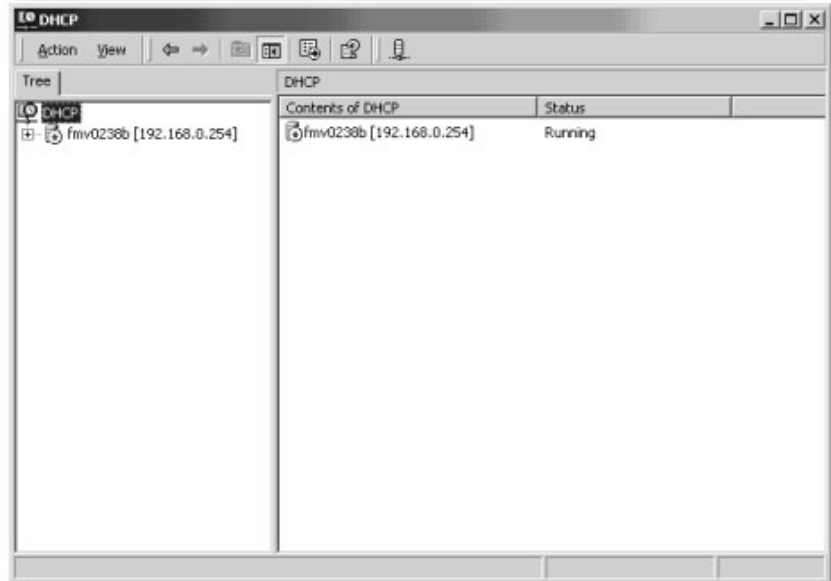

(2) Adding of scope

Click [Action]–[New Scope], and "New Scope Wizard" will start.



Click [Next]

Input "factory" to [Name], and do "FACTORY" to [Description].

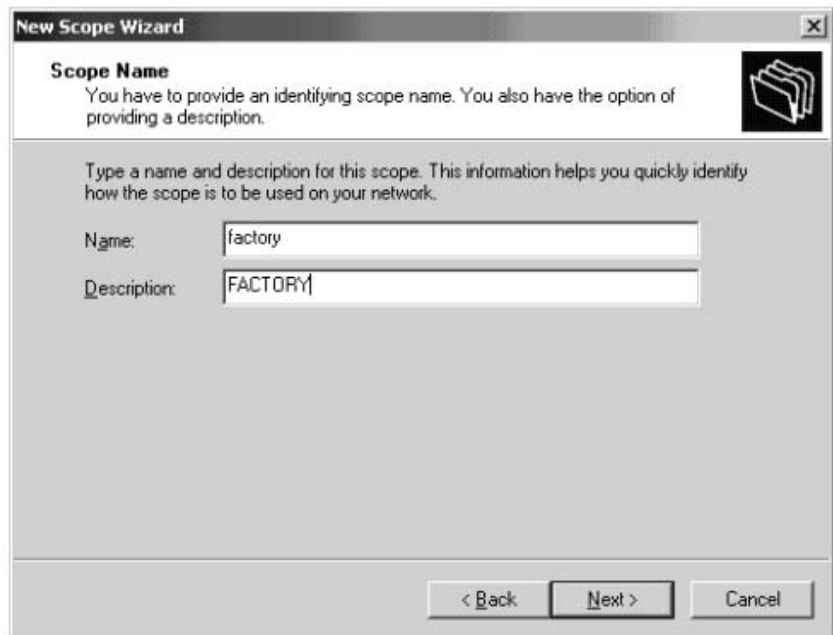

The screenshot shows the 'New Scope Wizard' dialog box. The title bar reads 'New Scope Wizard'. The main heading is 'Scope Name'. Below the heading, it says: 'You have to provide an identifying scope name. You also have the option of providing a description.' There is a folder icon on the right. Below this, it says: 'Type a name and description for this scope. This information helps you quickly identify how the scope is to be used on your network.' There are two input fields: 'Name:' with the text 'factory' and 'Description:' with the text 'FACTORY'. At the bottom, there are three buttons: '< Back', 'Next >', and 'Cancel'.

Click [Next].

Input "192.168.0.10" to [Start IP address], "192.168.0.29" to [End IP address], "24" to [Length], and "255.255.255.0" to [Subnet mask] respectively.

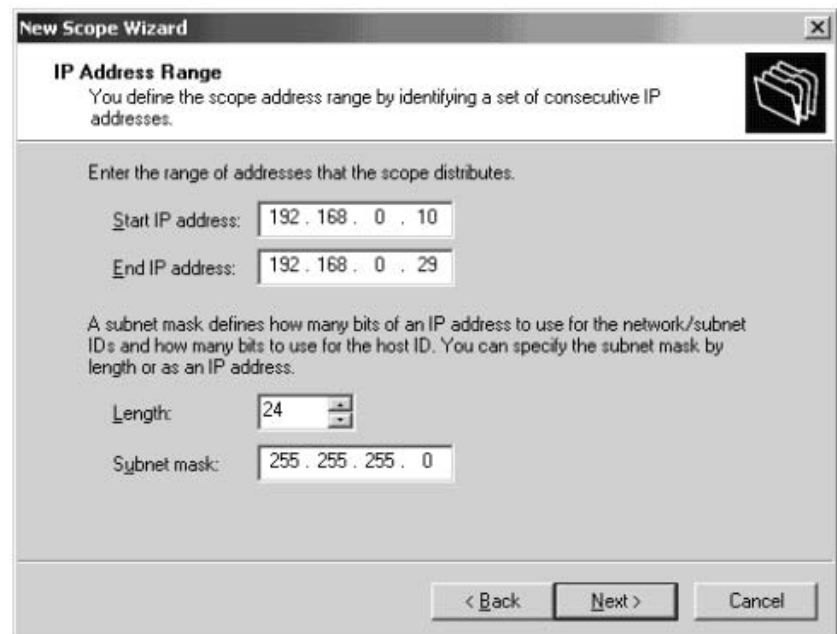

The screenshot shows the 'New Scope Wizard' dialog box. The title bar reads 'New Scope Wizard'. The main heading is 'IP Address Range'. Below the heading, it says: 'You define the scope address range by identifying a set of consecutive IP addresses.' There is a folder icon on the right. Below this, it says: 'Enter the range of addresses that the scope distributes.' There are four input fields: 'Start IP address:' with the text '192 . 168 . 0 . 10', 'End IP address:' with the text '192 . 168 . 0 . 29', 'Length:' with a spin box containing '24', and 'Subnet mask:' with the text '255 . 255 . 255 . 0'. At the bottom, there are three buttons: '< Back', 'Next >', and 'Cancel'.

Click [Next].



Click [Next] without modification.

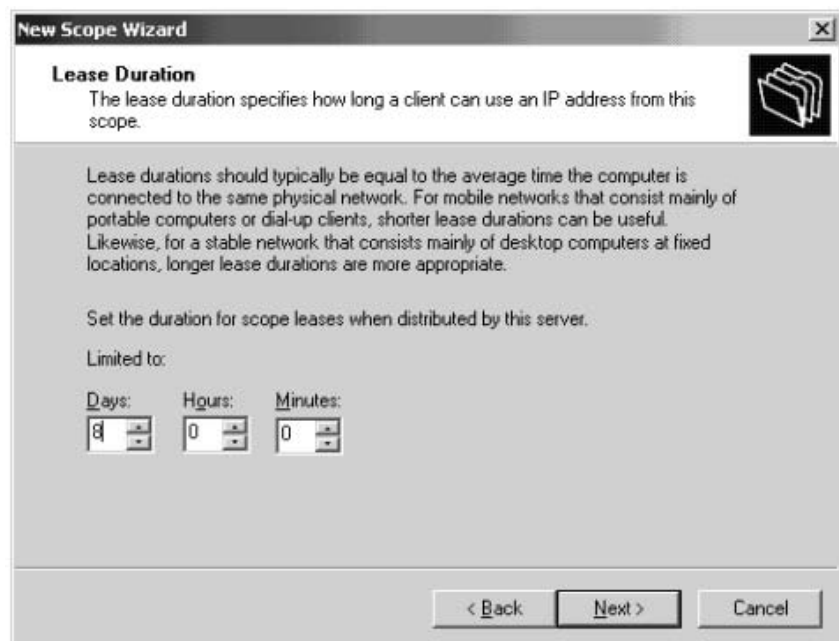

Confirm that Lease Duration is "8 days". Then click [Next].

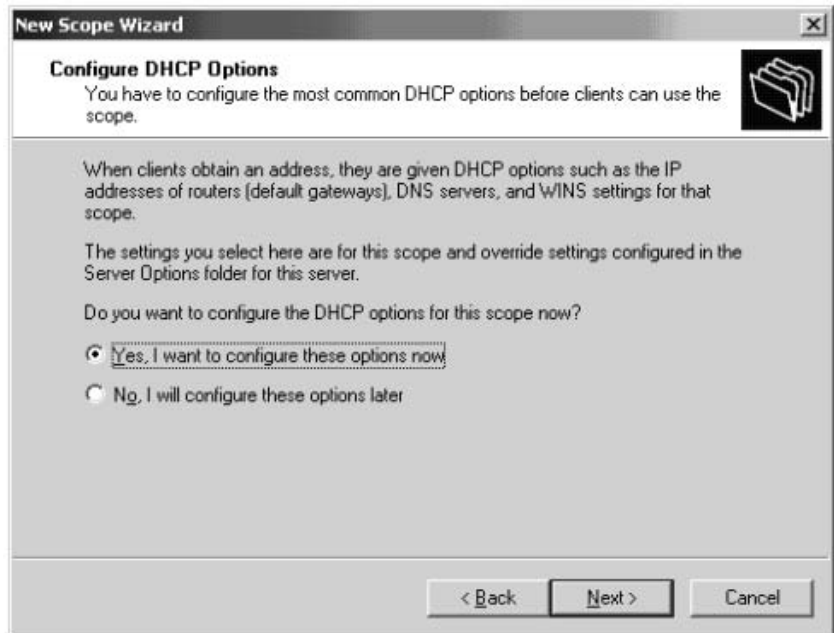

Confirm that [Yes, I want to...] is checked. Then click [Next].



Click [Next] without modification.

Input "192.168.0.254", and then click [Add].

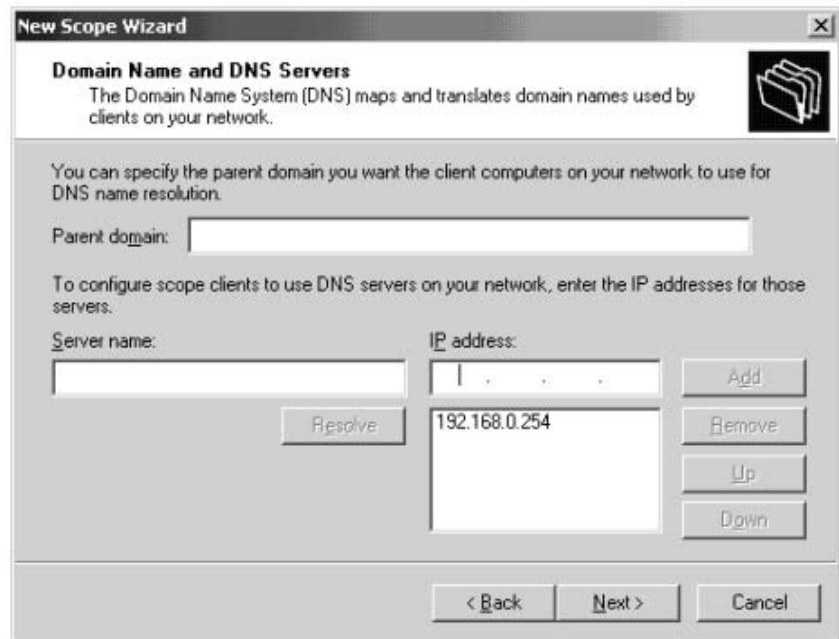

Click [Next].

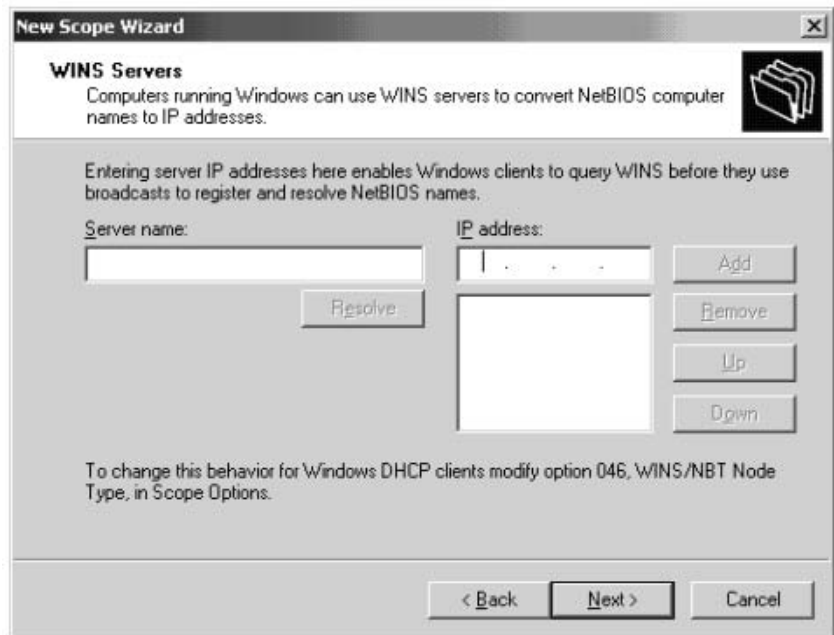

Click [Next] without modification.

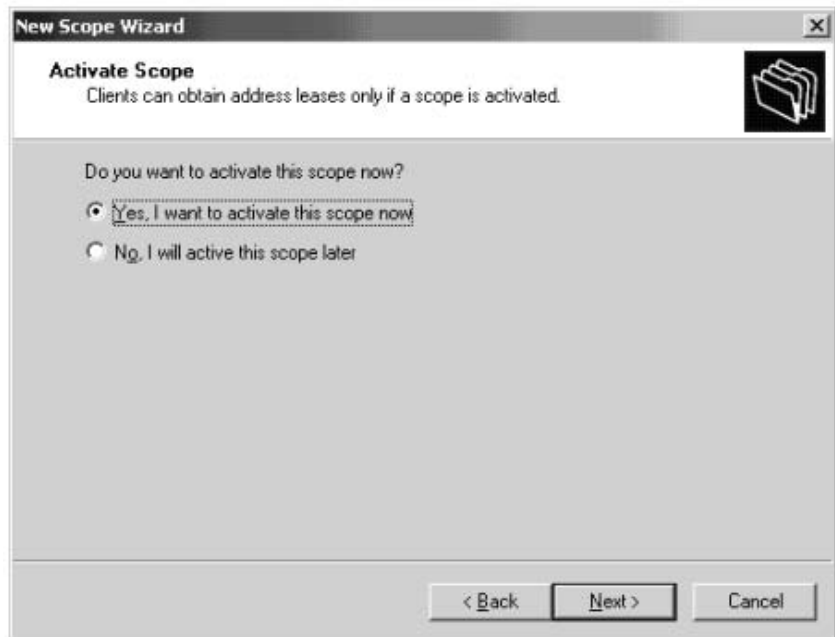

Confirm that [Yes, I want to ...] is checked. Then click [Next].



Click [Finish].

(3) Adding of scope option

Click [Scope[192.168.0.0]factory]–[Scope Options]–[Action]–[Configure Options].

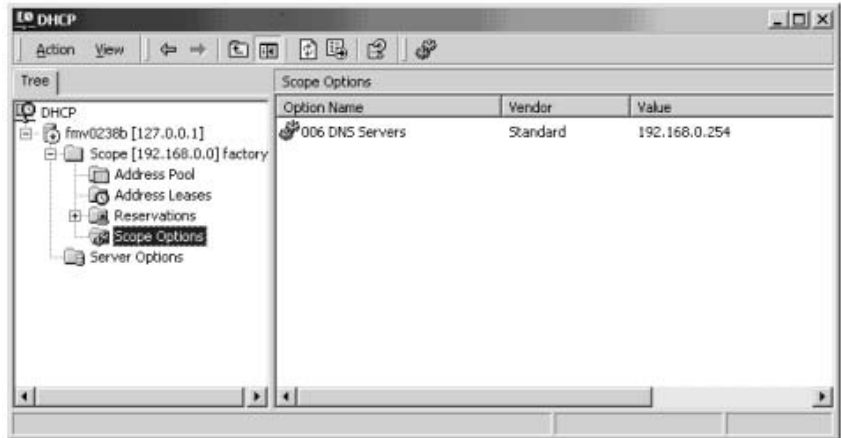

Check [DNS Domain Name], and then input "factory".

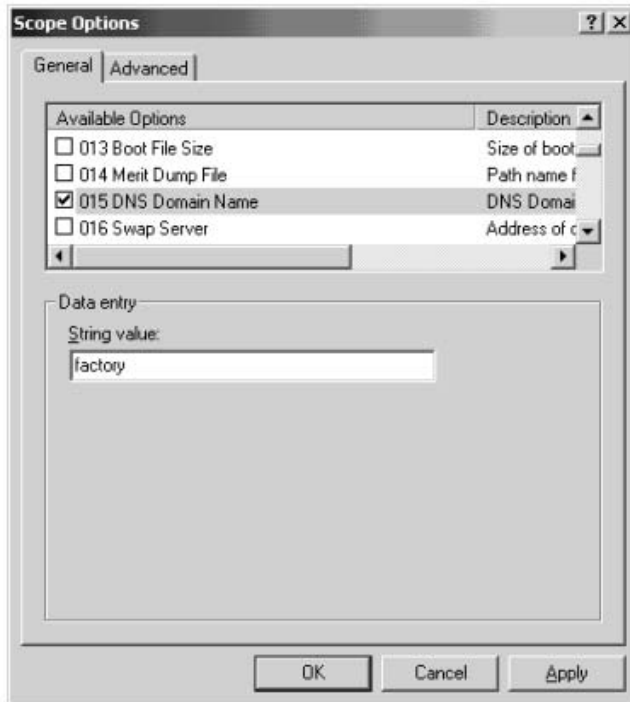

Click [OK].

The configured parameters are displayed as follows.

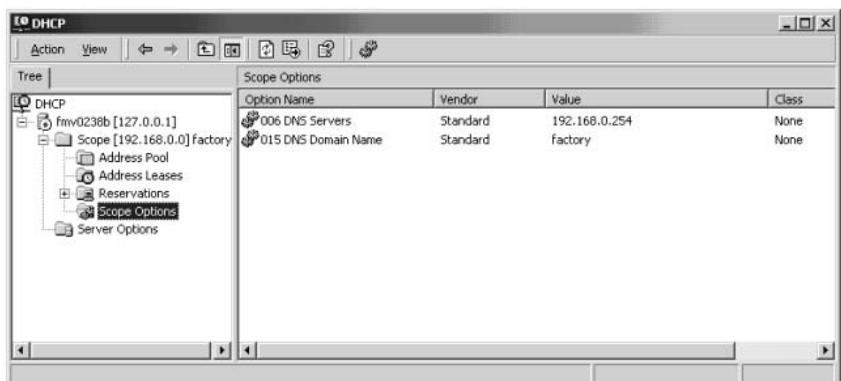

(4) Setting for referring to Dynamic DNS

Click [Scope[192.168.0.0]factory]–[Scope]–[Properties].

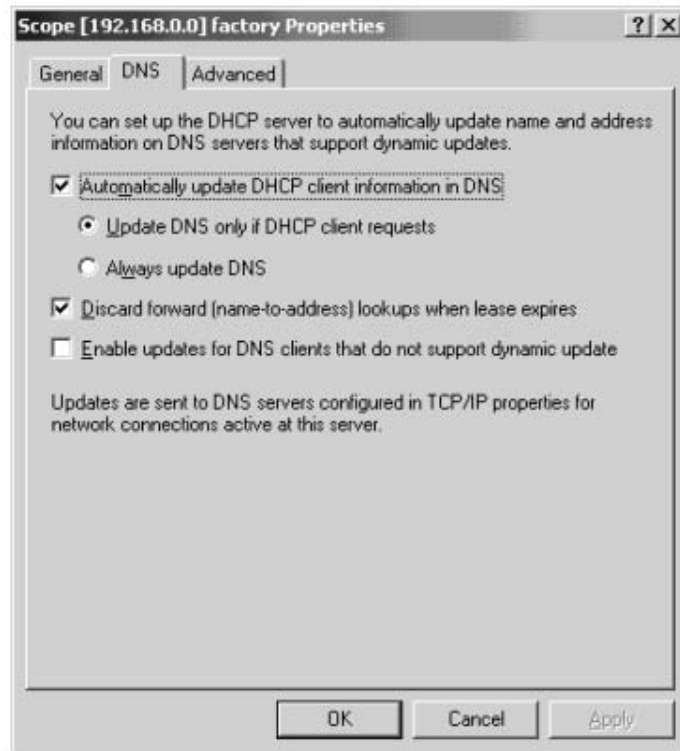

Check the items like the following figure.

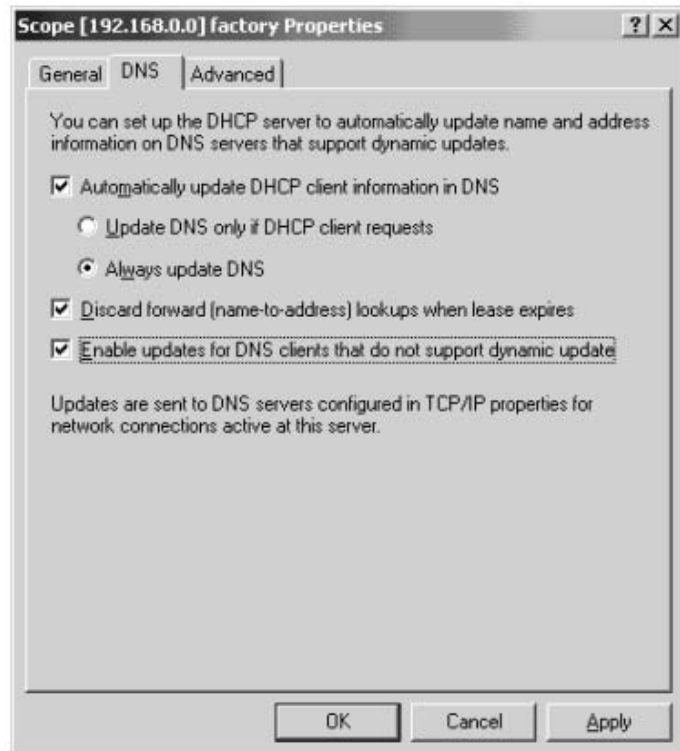

Click [OK]

Then the setting of DHCP server is finished.

17.8.4.2 Example of DNS server settings on Windows2000 Server

(1) Start of Microsoft management console (DNS)

This section explains the procedure of DNS server settings.

Click [Programs]–[Administrative Tools]–[DNS].

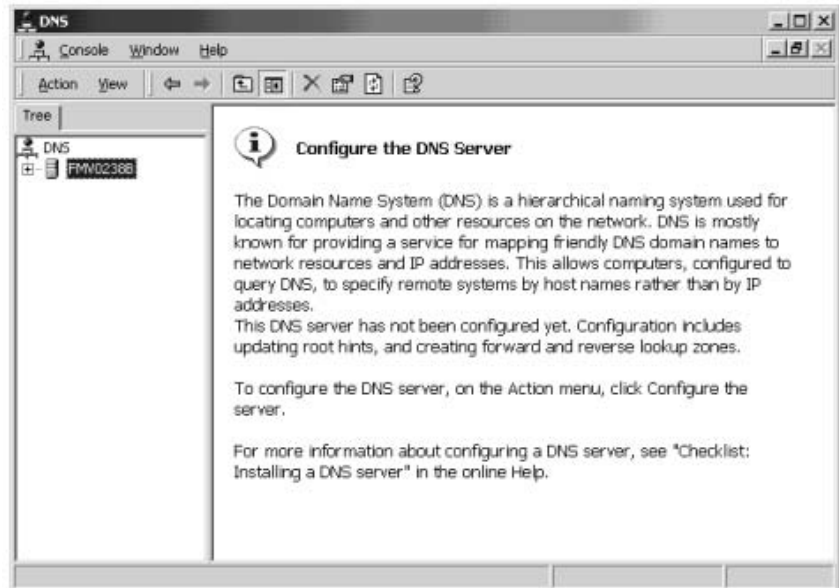

(2) Configuring of DNS server

Click [Action]–[Configure the server]. Then the Configure DNS Server Wizard will appear.



Click [Next].

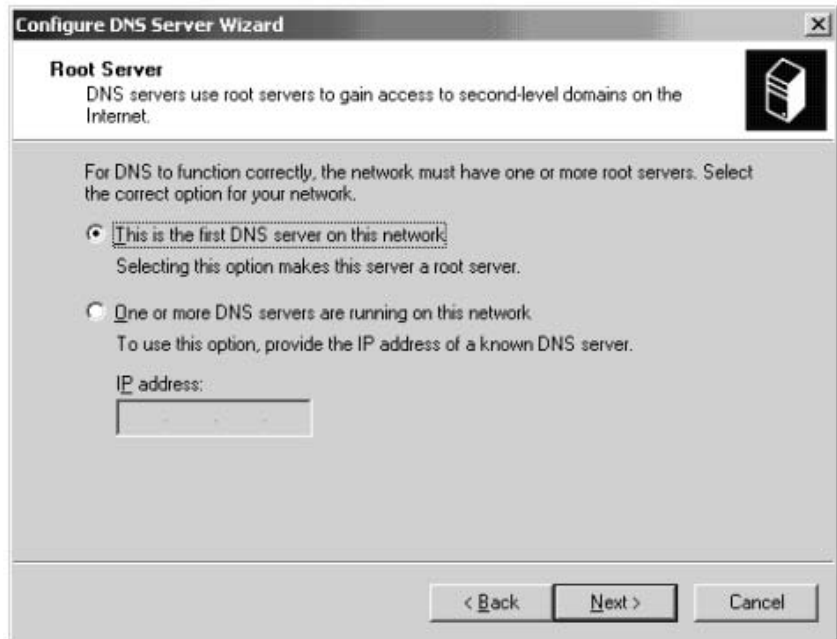

Confirm that [This is the first DNS...] is checked. Then click [Next].

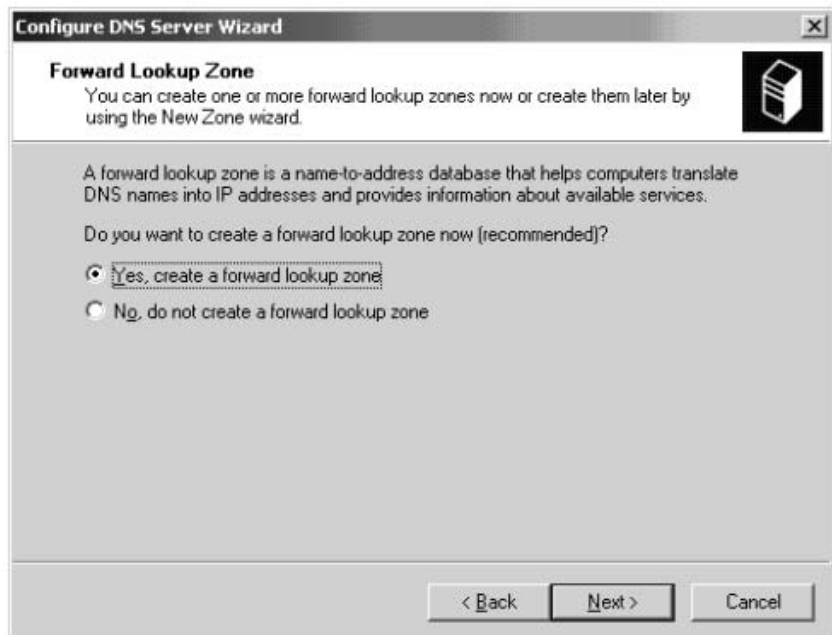

Confirm that [Yes, create a forward...] is checked. Then click [Next].



Confirm that [Standard primary] is checked. Then click [Next].
Input "factory.". (Don't forget the last period".")

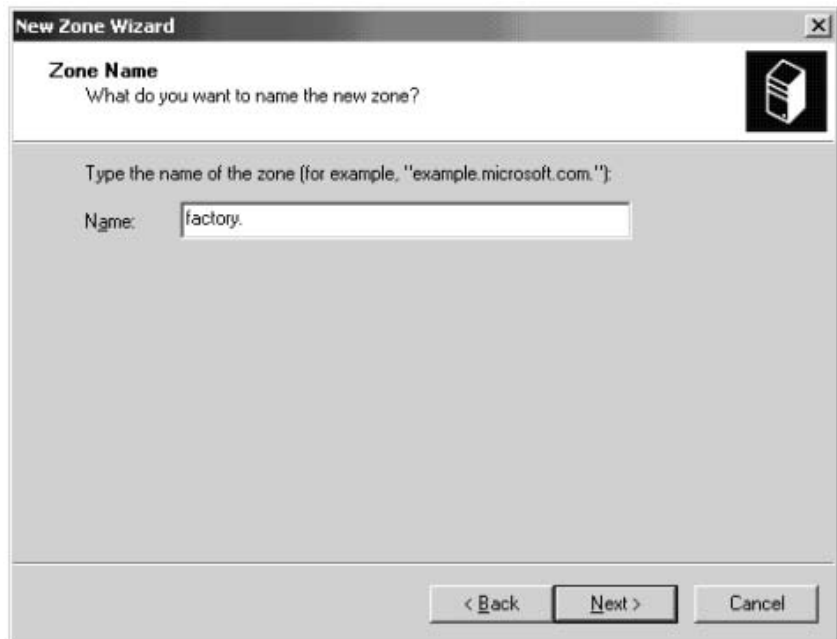

Click [Next].



Confirm that [Create a new file...] is "factory.dns". Then click [Next].

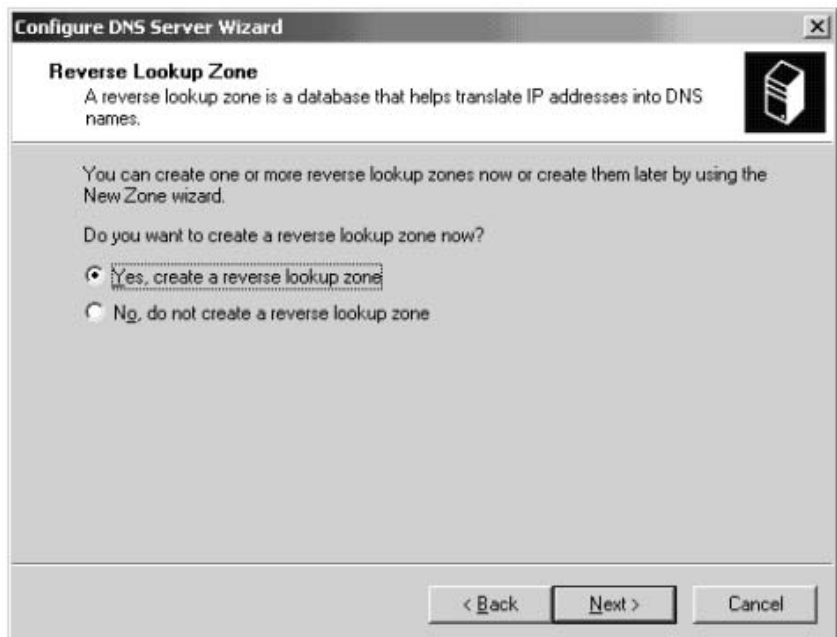

Confirm that [Yes, create...] is checked. Then click [Next].



Confirm that [Standard primary] is checked. Then click [Next].
Input "192.168.0".

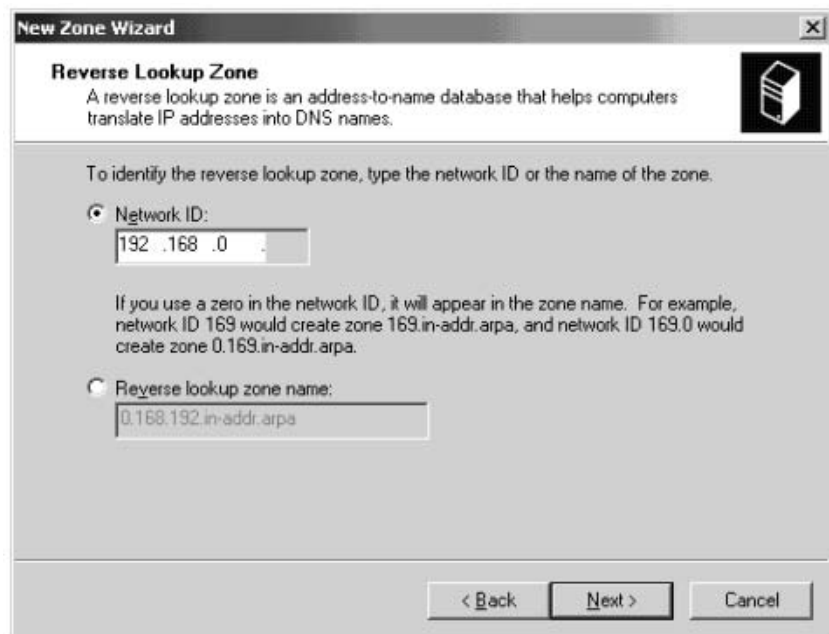

Click [Next].

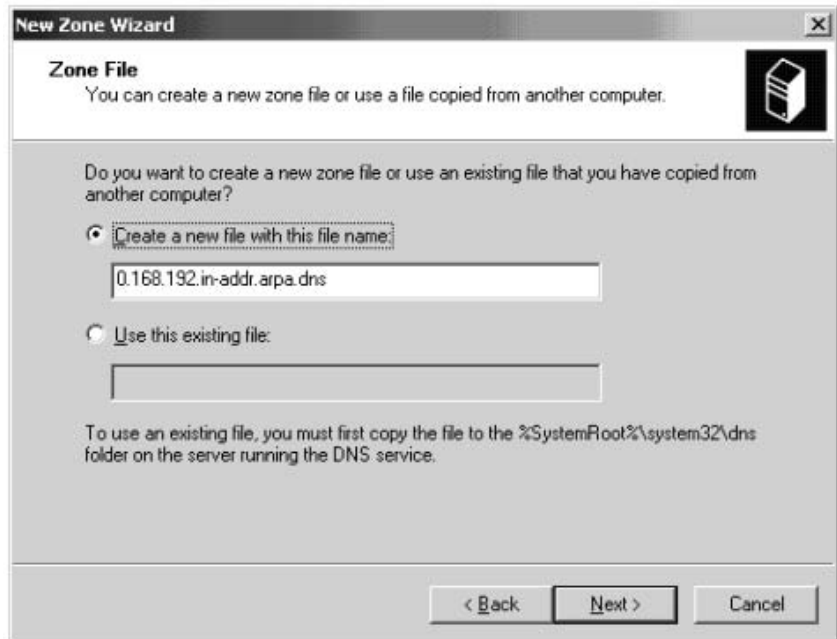

Confirm that [Create a new file...] is "0.168.192.in-addr.arpa.dns". Then click [Next].



Click [Finish].

(3) Allowing of Dynamic DNS

Click [Forward Lookup Zones]--[factory] with using the right side button.

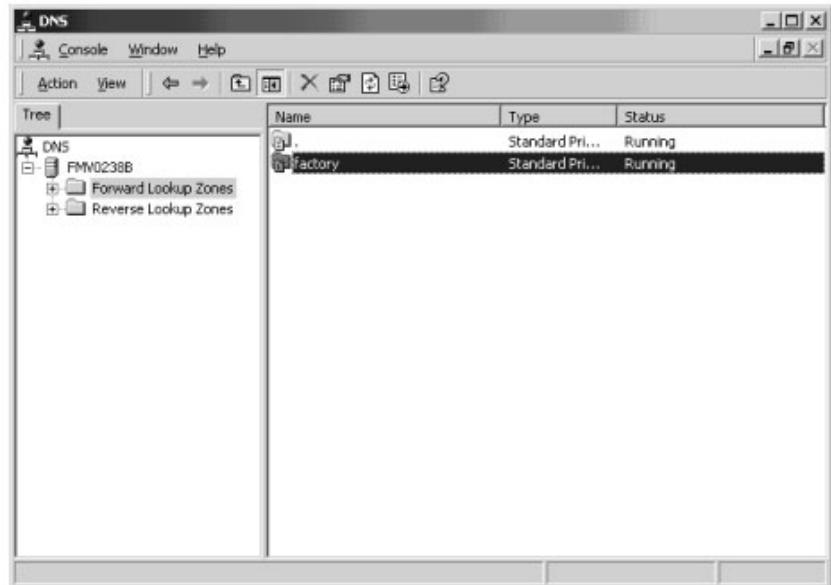

And then click [Properties].

Choose "Yes" from [Allow dynamic updates?].

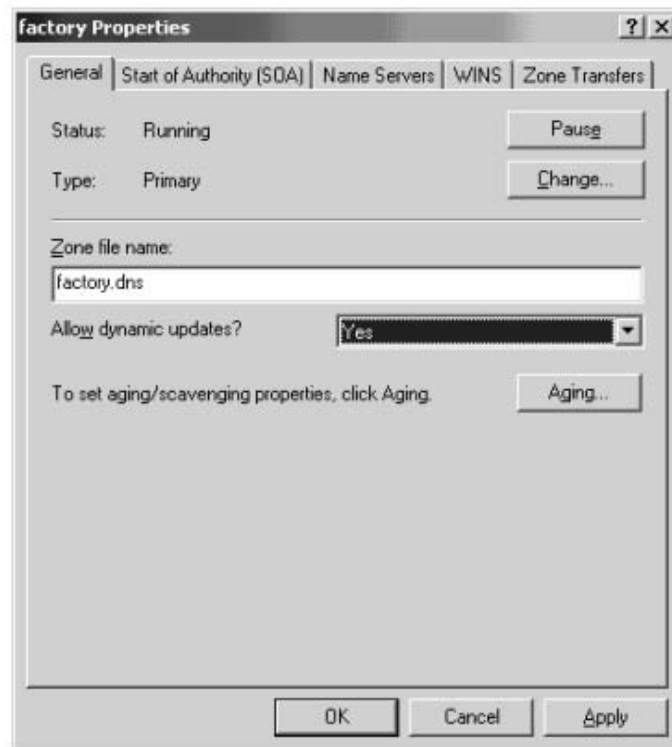

Click [OK].

Then the setting of DNS server is finished.

17.8.5 Application of DHCP and DNS to FOCAS1/Ethernet function

The Ethernet parameters of CNC can be configured by utilizing a DHCP/DNS server, without CNC setting operation.

DHCP is the network function which can assign a unique IP address to the devices on a network automatically.

17.8.5.1 Flow of action

When a CNC is rebooted

- (1) CNC with "Host Name" demands a IP address from a DHCP server.
- (2) The DHCP server sends back a unique IP address.
- (3) Furthermore, the DHCP server informs DNS server of the relationship between "Host Name" and the corresponding IP address.
The DNS server refreshes its database according to the above DHCP information.

When a FOCAS1/Ethernet application software is running

- (4) An application software calls a remote CNC with "Host Name".
- (5) The PC asks the DNS server the IP address corresponding with "Host Name".
- (6) The PC gets the IP address and tries to access the CNC.

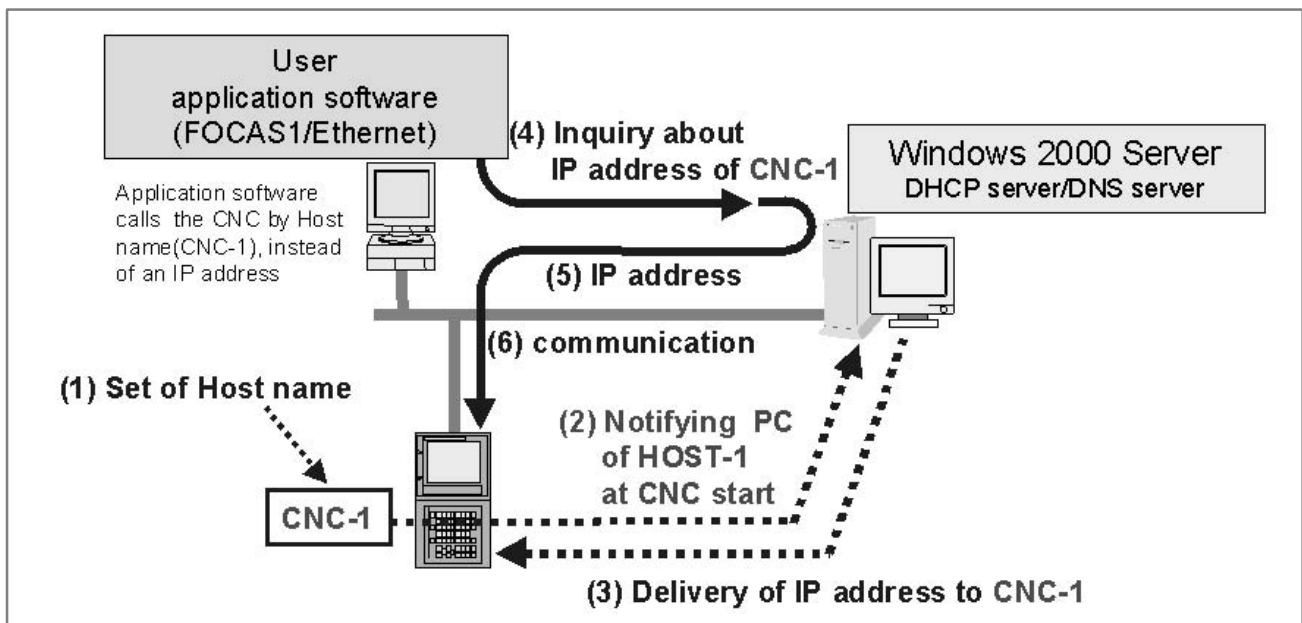

17.8.5.2

Setting of a PC

(1) Operating system

Windows2000 Server or later is recommended.
(DHCP/DNS server needs to support Dynamic DNS.)

(2) Setting of DHCP server

The following items need to be configured in DHCP server.

- 1) Range of IP addresses which can be leased by DHCP server
- 2) Sub-net mask
- 3) IP address for DNS server
- 4) Domain

As for detailed settings of DHCP server, please refer to "17.8.4.1. Example of DHCP server settings on Windows2000 Server".

(3) Setting of DNS server

The following items need to be configured in DNS server.

- 1) Dynamic DNS function

As for detailed settings of DNS server, please refer to "17.8.4.2. Example of DNS server settings on Windows2000 Server".

17.8.5.3

Settings of CNC

(1) Parameters

- 1) Parameter No.14880#6 needs to be set in order to use DHCP function of the CNC.
- 2) "Host name" is named automatically according to the following rule.
Default "Host name": NC-< MAC address of Embedded Ethernet>
Example: NC-080019123456
And "Host name" can be modified freely from CNC settings menu.
- 3) When Parameter No.14880#6 is set, Embedded Ethernet sets the default parameters automatically as follows.
In the case that Parameter No.14880#3=0 (FOCAS1/Ethernet)

TCP port number	8193
UDP port number	0
Time interval	0

 In the case that Parameter No.14880#3=1 (DNC1/Ethernet)

TCP port number	8193
UDP port number	8192
Time interval	50

17.9 TROUBLESHOOTING

This section describes troubleshooting and check items associated with the embedded Ethernet function.

17.9.1 Check Items Related to Connection with the Hub

- 1) Is an STP cable used for connection between the hub and embedded Ethernet?
- 2) Is the STP cable connected correctly?
In general, a straight cable is used for connection between the hub and communication device.
- 3) Is the power to the hub turned on?
- 4) The PCMCIA Ethernet card is used only with 10BASE-T. Is a hub for 10BASE-T used when the PCMCIA Ethernet card is used?
- 5) Is the link LED turned on when the embedded Ethernet port is used?
The link LED is not turned on when the hub is not connected or the power to the hub is not turned on.
- 6) Is the LED (for link display) of the connected hub turned on?
(Some hubs are not provided with a link LED.)
The LED is not turned on when the hub is not connected with the embedded Ethernet or the power to the CNC is not turned on.

17.9.2 Check Items Related to Connection with a Backbone

This subsection can be ignored when a network is built only with a hub to which the embedded Ethernet is connected.
The general check items are listed below. For network installation, consult with vendors specialized in this area. Install cables away from noise sources.

When a 10BASE-5 backbone is used

- 1) Are transceivers connected to the backbone cable correctly?
 - If the transceivers are connected correctly, the resistance between the backbone shield and central conductor is about 25 ohms (when terminating resistors are attached).
 - A special tool may be required for transceiver installation. (The special tool varies from one vendor to another. For details, refer to the relevant manual of each vendor.)
 - At a location where a transceiver was once installed, do not install a transceiver again. (The backbone cable can be damaged.)
- 2) Are transceivers installed at correct intervals?
 - Transceivers need to be spaced from each other by 2.5 m or more. It is recommended that transceivers be installed at intervals of an integral multiple of 2.5 m. Usually, installation locations are marked on a backbone cable.
- 3) Are terminating resistors attached?
 - A terminating resistor (50 ohms) needs to be attached to each end of the backbone cable.

- 4) Is the length of the backbone cable 500 m or less?
- 5) Does the cable (transceiver cable) connecting a hub to a transceiver satisfy the specified length?
 - Usually, the maximum allowable length of a transceiver cable is 50 m. However, the maximum allowable length of some thin cables may be less than 50 m. Check the specification of the cable.

When a 10BASE-2 backbone is used

- 1) Is the length of one cable 0.5 m or more?
 - The minimum allowable span between nodes (devices) is 0.5 m.
- 2) Is the length of the backbone cable (total length of the cables) 185 m or less?
- 3) Are terminating resistors attached?
 - A terminating resistor (50 ohms) needs to be attached to each end of the backbone cable.

17.9.3 Checking the Setting of Each Parameter

This subsection describes how to check the minimum settings required for communication.

Checking the settings on the embedded Ethernet side

- 1) Is the MAC address of the embedded Ethernet displayed?
 - The MAC address of a embedded Ethernet port is set for each CNC, and can be checked on the parameter setting screen.
 - A unique MAC address is assigned to each PCMCIA Ethernet card. When a PCMCIA Ethernet card is selected and inserted, MAC address display is provided.
- 2) Is a correct IP address set?
 - Check if an IP address already specified for another device is set.
- 3) Is a correct subnet mask set?
 - The subnet mask setting must match the subnet mask setting on the communication destination device.
- 4) Is a correct router IP address set when communication via a router is performed?

Checking the settings on the personal computer side

- 1) Is a correct IP address set?
 - Check if an IP address already specified for another device is set.
- 2) Is a correct subnet mask set?
 - The subnet mask setting must match the subnet mask setting on the communication destination device.
- 3) Is a correct router IP address set when communication via a router is performed?

17.9.4 Checking Communication

This subsection describes how to check the state of communication between the CNC and personal computer.

Checking the connection status and settings

If communication with the CNC is not satisfactory or fails from time to time, check the communication link by using the method described below. The ping command is used to check communication.

Checking from the embedded Ethernet side

See Item 6 of Section 17.7, "EMBEDDED ETHERNET MAINTENANCE SCREEN".

If no response is received from the remote device, the cause is considered to be a hardware connection error and/or software setting error. Check the hardware connection and software settings.

Checking from the personal computer side

An example where a personal computer (OS: Windows NT 4.0) is used is described below.

Method of checking:

Open the command prompt, then enter "ping NC-IP-address". A normal connection has been established if a response is received.

The example below supposes that the IP address of the CNC is 192.168.1.1.

1) When a response is received (normal)

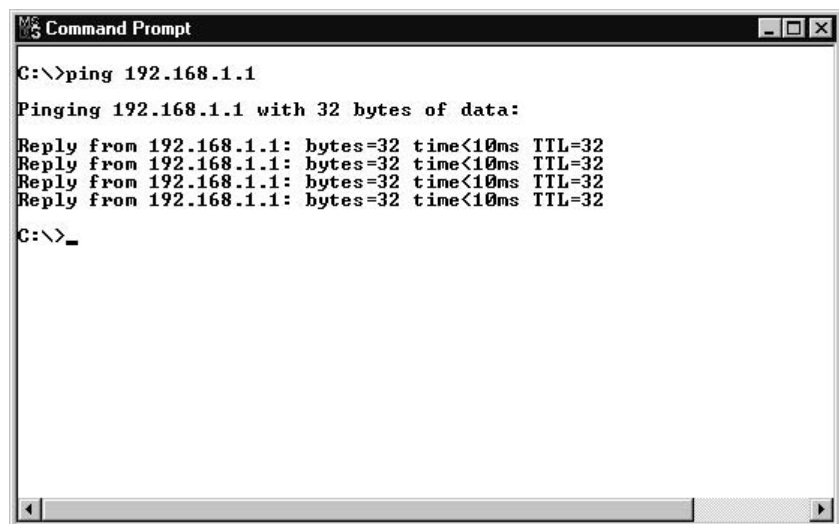

```
Command Prompt
C:\>ping 192.168.1.1
Pinging 192.168.1.1 with 32 bytes of data:
Reply from 192.168.1.1: bytes=32 time<10ms TTL=32
Reply from 192.168.1.1: bytes=32 time<10ms TTL=32
Reply from 192.168.1.1: bytes=32 time<10ms TTL=32
Reply from 192.168.1.1: bytes=32 time<10ms TTL=32
C:\>_
```

2) When no response is received (error)

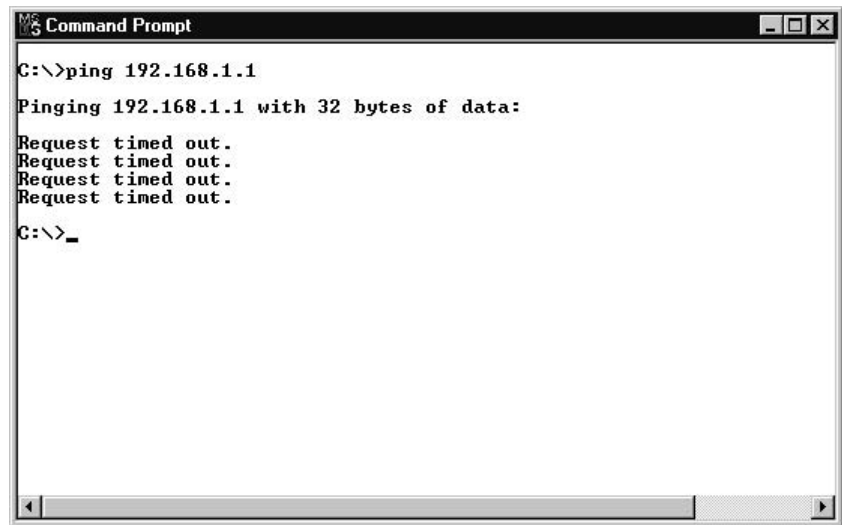

```

C:\>ping 192.168.1.1
Pinging 192.168.1.1 with 32 bytes of data:
Request timed out.
Request timed out.
Request timed out.
Request timed out.
C:\>_

```

If no response is received from the CNC, the cause is considered to be a hardware connection error and/or software setting error. Check the hardware connection and software settings.

Checking the influence of noise

The method of checking communication errors caused by noise is described below.

The ping command is used for this checking as well.

The `-t` option of the ping command is used. Until the "Ctrl + C" keys are pressed simultaneously, ping packets are transmitted.

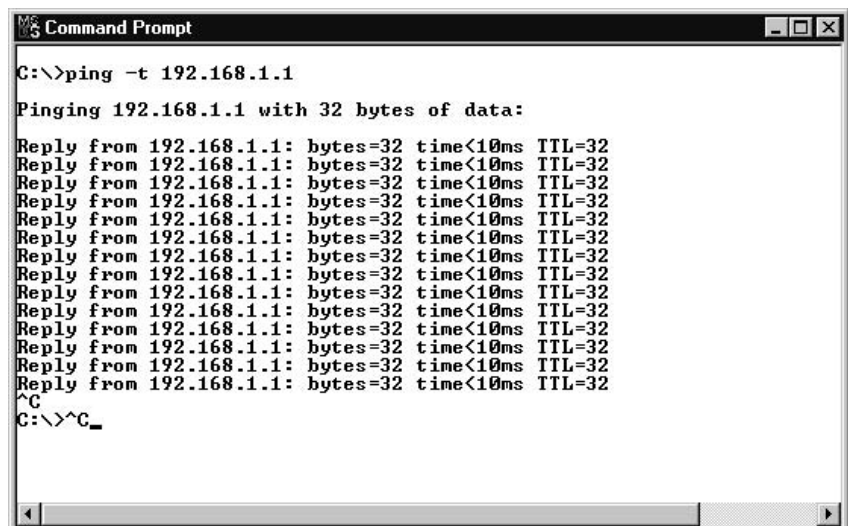

```

C:\>ping -t 192.168.1.1
Pinging 192.168.1.1 with 32 bytes of data:
Reply from 192.168.1.1: bytes=32 time<10ms TTL=32
Reply from 192.168.1.1: bytes=32 time<10ms TTL=32
Reply from 192.168.1.1: bytes=32 time<10ms TTL=32
Reply from 192.168.1.1: bytes=32 time<10ms TTL=32
Reply from 192.168.1.1: bytes=32 time<10ms TTL=32
Reply from 192.168.1.1: bytes=32 time<10ms TTL=32
Reply from 192.168.1.1: bytes=32 time<10ms TTL=32
Reply from 192.168.1.1: bytes=32 time<10ms TTL=32
Reply from 192.168.1.1: bytes=32 time<10ms TTL=32
Reply from 192.168.1.1: bytes=32 time<10ms TTL=32
Reply from 192.168.1.1: bytes=32 time<10ms TTL=32
Reply from 192.168.1.1: bytes=32 time<10ms TTL=32
Reply from 192.168.1.1: bytes=32 time<10ms TTL=32
^C
C:\>^C_

```

1. Influence of noise from peripheral equipment (device)

- 1) Turn on the power to the machine with the embedded Ethernet function for which a noise influence check is to be made, and ensure that communication is enabled.
- 2) Press the emergency stop button of the machine to turn off servo/spindle amplifier activation, then issue a ping command from the personal computer.

- 3) Count the number of lost packets (to which no response is returned).

If lost packets occur in this state, there is probably an influence of noise from peripheral equipment.

Action: Locate the noise source and recheck the cabling to eliminate the influence of noise.

2. Influence of noise from the installed machine

- 1) Next, release the emergency stop state of the machine to turn on servo/spindle amplifier activation, then issue another ping command from the personal computer.
- 2) Count the number of lost packets.

If this number is greater than the number of Item 1 above, the cause is considered to be noise generated by the machine itself. In general, the grounding of the machine or the grounding of the communication destination is defective.

Action: Check the grounding of the machine and the communication destination, and insulate the machine from the communication backbone.

17.10 ERROR MESSAGES

If an error occurs with the embedded Ethernet function, the log screen of the embedded Ethernet function displays an error message.

This section describes error messages displayed on the log screen.

The major error messages are described below.

If an error occurs, display the log screen and check the error message to identify the cause of the error.

Multiple error messages may be displayed for an error. So, check the display times of error messages.

17.10.1 EMB_ETH MASTER CTRL LOG Screen

OWN IP ADDRESS IS NOTHING

The IP address of the local node is not set. Set an IP address correctly.

OWN IP ADDRESS(???) IS INVALID

The setting (???) of the IP address of the local node is incorrect. Correct the IP address.

SUBNET MASK IS NOTHING

The subnet mask of the local node is not set. Set a correct subnet mask.

SUBNET MASK(???) IS INVALID

The setting (???) of the subnet mask of the local node is incorrect. Correct the subnet mask.

ROUTER IP ADDRESS(???) IS INVALID

The setting (???) of the IP address of the router is incorrect. Correct the IP address of the router.

TCP PORT NUMBER(???) IS INVALID

The setting (???) of the TCP port number is incorrect. Correct the TCP port number.

UDP PORT NUMBER(???) IS INVALID

The setting (???) of the UDP port number is incorrect. Correct the UDP port number.

UDP INTERVAL TIME(???) IS INVALID

The setting (???) of the time interval for UDP transmission is incorrect. Correct the time interval.

Embedded LANC SelfTest Error [???)

An error was detected when the LAN controller of the embedded Ethernet was initialized.

The error code is [???). Hardware replacement is needed.

17.10.2 EMB_ETH FOCAS1/ETHER LOG Screen

TCP PORT NUMBER(???) IS INVALID

The setting (???) of the TCP port number is incorrect. Correct the TCP port number.

Illegal Broadcast IP ADDRESS

The broadcast address for UDP transmission is incorrect. Correct the subnet mask and IP address of the local node.

Illegal Power-on Date or Time

The current time setting of the CNC is incorrect. Correct the clock of the CNC.

ALL TASKS(C1) ARE BUSY

The FOCAS1/Ethernet function or DNC1/Ethernet function is already engaged in communication with five applications. Terminate unnecessary communication applications on the personal computer.

If the cable is disconnected before communication is completed, the embedded Ethernet may need to be reset and initialized.

Err accept() [???

An error occurred when a connection request from the personal computer is being awaited. The error code is [???]. This error message is output, for example, when the embedded Ethernet is reset.

Err recv() [???

An error occurred during data reception. The error code is [???].

This error message is output, for example, when the embedded Ethernet is reset before communication is closed.

17.10.3 EMB_ETH FTP TRANSFER LOG Screen

Login User is invalid

The setting of the user name or password is incorrect. Check the user name and password.

Parameters are invalid

The port number and IP address of the host computer set on the parameter setting screen are incorrect. Check the settings of the port number and IP address.

(???) is not found

The host computer with which an attempt is made to perform FTP communication cannot be found on the network. The IP address of the host computer to be connected with is indicated by (???). Check if the power to the host computer is turned on and if the host computer is connected to the network correctly.

17.10.4 EMB_ETH FACTOLINK LOG Screen

FACTOLINK#1 IP ADDRESS(???) IS INVALID

The setting of the IP address (???) of the FACTOLINK server is incorrect. Check the setting of the IP address.

FACTOLINK#1 PORT NUMBER(???) IS INVALID

The port number (???) of the FACTOLINK server is incorrect. Check the setting of the program number.

Err ALREADY CONNECTED

An additional request is made for connection with a port already connected.

The embedded Ethernet needs to be reset.

17.11 GLOSSARY FOR ETHERNET TCP/IP

This section briefly describes Ethernet-related terms.

The descriptions below provide minimum information only. For further information, refer to relevant publications available on the market.

For Ethernet-based communication, the TCP/IP (Transmission Control Protocol/Internet Protocol) protocol is generally used. A protocol is a set of rules used to ensure smooth communication between communication devices connected via a transmission line. The TCP/IP protocol is a part of the hierarchical structure consisting of the protocols and services indicated below.

Hierarchy	Protocol/network service
Application layer	User services such as FTP
Transport layer	Protocols such as TCP and UDP
Network layer	Protocols such as IP and ICMP
Data link layer	Protocols such as ARP and RARP
MAC layer	
Physical layer	Hardware such as cables and devices

In general, the TCP/IP protocol is a generic term that represents the protocols installed in the transport layer and network layer.

IP address (INET address)

With TCP/IP, an address referred to as an IP address (INET address) is used to identify a specified communication device among the communication devices connected via Ethernet. So, for communication using TCP/IP, each communication device connected to Ethernet must have a unique IP address assigned.

An IP address is four octets (bytes) long. Usually, an IP address is represented by four 8-bit (octet or byte) fields separated by a period from each other. Each octet can have a value from 0 to 255.

An IP address consists of the address of the network to which the communication device is connected, and the host address of the communication device. Networks are classified into three classes by group size: class A, class B, and class C.

	First octet value	Network address section	Host address section
Class A	0 to 127	xxx.xxx.xxx.xxx	xxx.xxx.xxx.xxx
Class B	128 to 191	xxx.xxx.xxx.xxx	xxx.xxx.xxx.xxx
Class C	192 to 223	xxx.xxx.xxx.xxx	xxx.xxx.xxx.xxx

(A hatched portion indicates the section of each address.)

If a network supports no more than 255 communication devices, class C is generally used.

The IP addresses of all communication devices on one network have the same network address, and only the host address of each communication device is unique on the network.

An IP address with its network address and host address all set to 0 or 255 is unusable.

IP addresses are internationally managed systematically. This means that before an IP address can be used, the IP address must be obtained formally from the international organization.

If the network used by a user is a local network closed within the user's environment (not connected to an outside network), unique IP addresses may be set freely under the control and responsibility of the user. For a local network, the following network addresses can be used without formal registration: 1 address (10) for class A, 16 addresses (172.16 to 172.31) for class B, and 256 addresses (192.168.0 to 192.168.255) for class C. So, it is recommended that IP addresses with these network addresses be used for a local network.

Subnet mask (mask address)

Mask address for indicating the network address section of an IP address. For a network of class A, specify 255.0.0.0. For a network of class B, specify 255.255.0.0. For a network of class C, specify 255.255.255.0.

MAC address (Ethernet address)

A MAC address is assigned to the Ethernet control board of each communication device, and is used to identify each communication device on the MAC layer (lower part of the data link layer). A unique address obtained from an international organization is used so that no address duplication occurs among Ethernet control board suppliers.

Port number

The port number is a 16-bit integer used to associate the transport layer (TCP or UDP) of TCP/IP and a process of the application layer. Port numbers from 0 to about 8000 are called well-known port numbers and assigned to standard applications (such as Telnet and FTP). The assignment of port numbers is described in Assigned Numbers [RFC1340].

When using the FOCAS1/Ethernet function and DNC1/Ethernet function, assign port numbers other than the well-known port numbers.

Broadcast

Transmitting a message to all nodes in the same segment

Client

Device or application that requests a service

Server

Device or application that provides a service

18 TROUBLE DIAGNOSIS



18.1 TROUBLE DIAGNOSIS

18.1.1 Outline

Investigating the cause of Servo/Spindle/CNC alarms becomes easier by diagnosis according to the guidance message.
And when the thermal simulation or disturbance torque of servo axis exceeds the trouble forecast level, a trouble forecast signal can be output.

Step of diagnosis

- 1 Answer the question of the guidance message in the trouble diagnosis guidance screen by pushing soft keys [YES]/[NO].

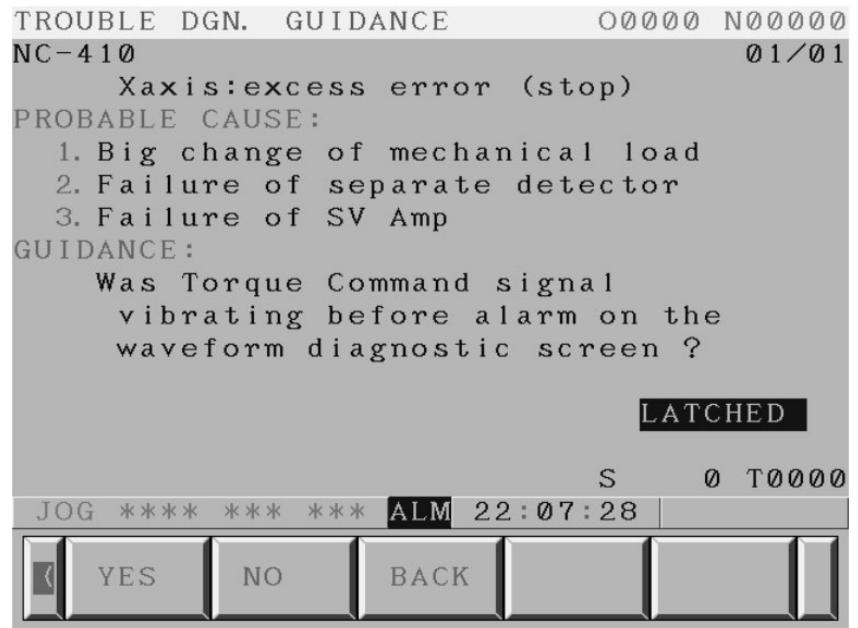

- 2 See the servo/spindle monitor information in the trouble diagnosis monitor screen and waveform of servo/spindle in the trouble diagnosis graphic screen in case of need according to the guidance message.

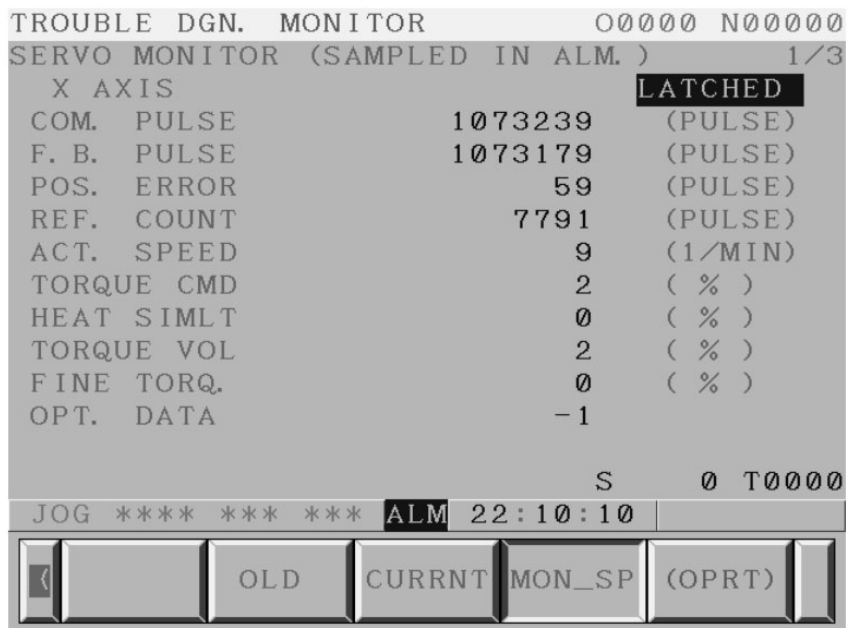

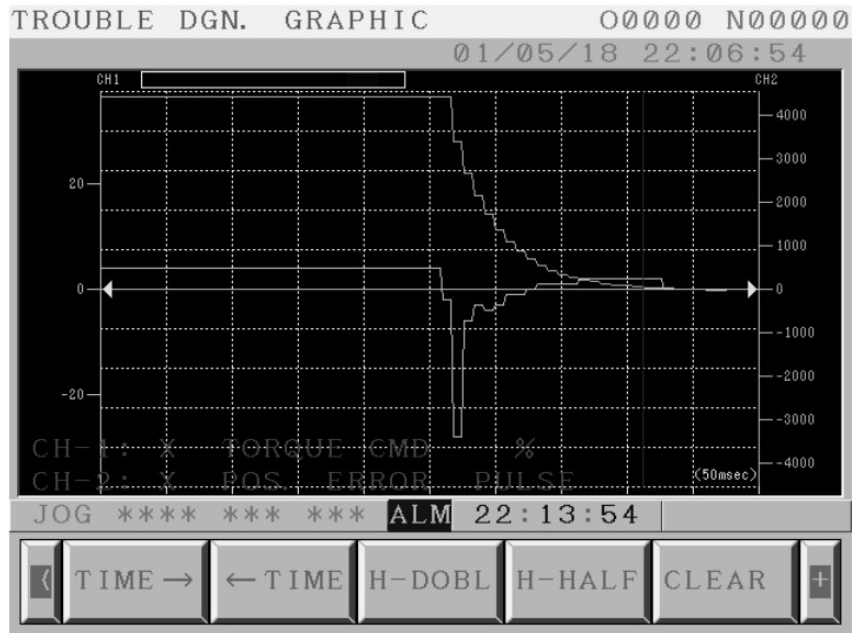

3 Finally, the guidance message in the trouble diagnosis guidance screen shows the probable cause of alarm and the method to remove the problem.

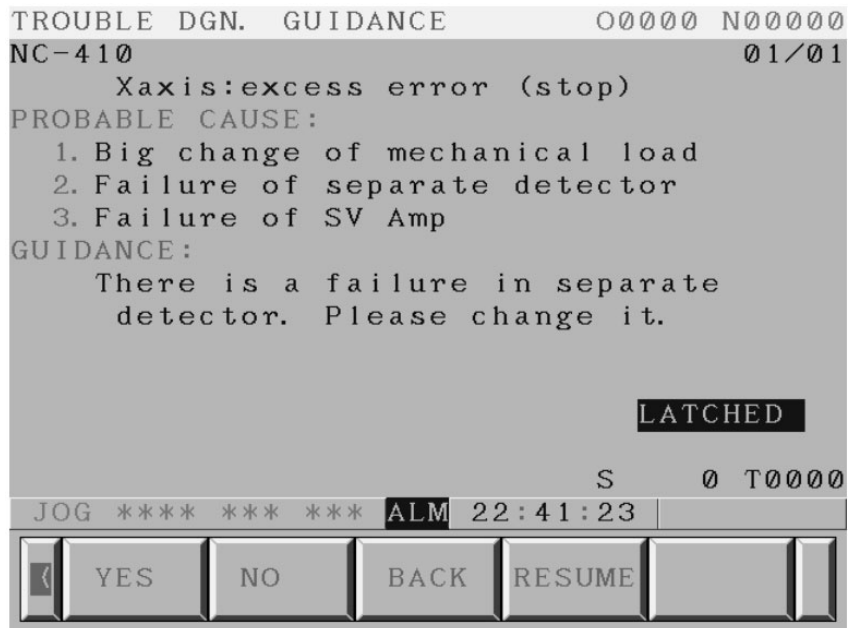

18.1.2 Trouble Diagnosis Guidance Screen

The trouble diagnosis guidance screen displays the guidance message to investigate the cause of an alarm.

Display

Display procedure

- 1 Press function key [Message].
- 2 Press the continuous menu key [>] and press soft key [GUIDE].

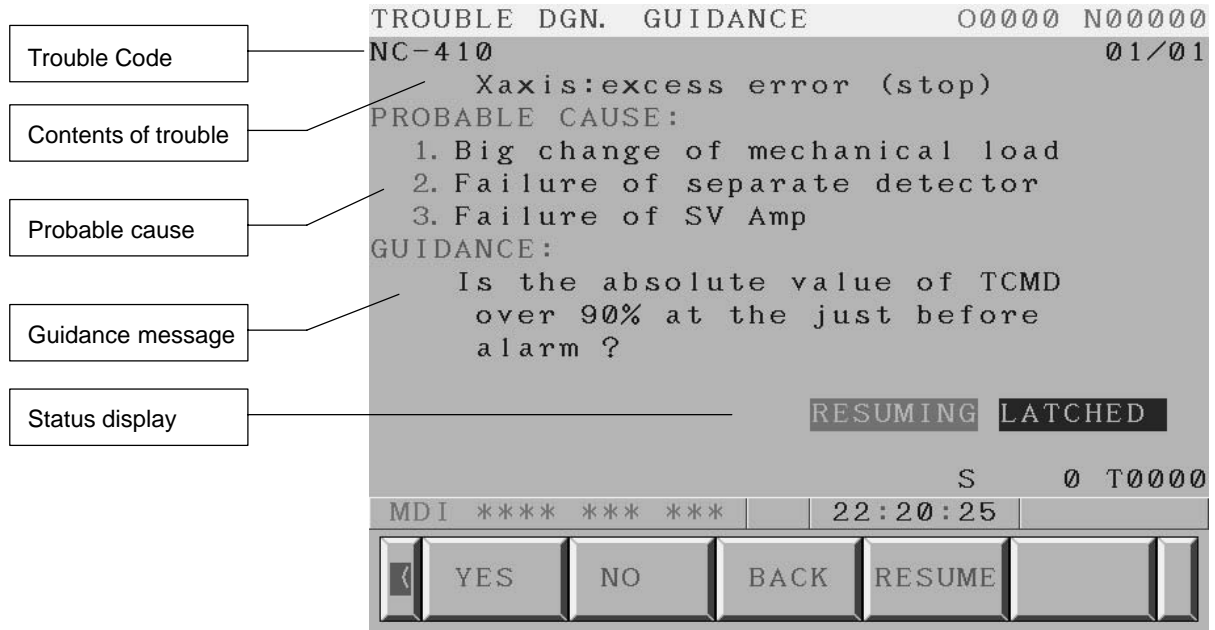

Contents of Display

- Trouble Code: Code for identifying alarm.
- Contents of Trouble: Alarm Message.
- Probable Cause: Probable Cause of alarm.
- Guidance message: Question to find the cause or answer to remove trouble is displayed.

Status display

[RESUMING]: When press soft key [RESUME] , the guidance message which was displayed before CNC power turned off is displayed again. Then [RESUMING] appears.

[LATCHED]/[SAMPLING]: [LATCHED] shows that servo/spindle monitor information is memorized. Alarm No. in the guidance screen and alarm no. which occurred when servo/spindle monitor data was memorized may be different. In this case the diagnosis may not done correctly. And then [LATCHED] blinks.

[SAMPLING] shows that servo/spindle monitor information is not memorized yet. Servo/spindle monitor information can be referred in Trouble Diagnosis Monitor Screen.

Operation

Change of Guidance

- [YES]/[NO]: Check contents of guidance message, and, answer by pressing soft key [YES] or [NO]. Then the next guidance message is displayed.
In some cases CNC automatically checks and judges contents of guidance. In this case the next guidance message is automatically displayed.
Automatic diagnosis is not done in case that CNC power turns off once after servo /spindle monitor information is memorized.
- [BACK]: Guidance message returns back 1 step.
It is possible to trace back the guidance message when [YES]/[NO] is pressed by mistake.
- [RESUME]: Guidance message which was displayed before CNC power tured off is displayed agein.If guidance is not done once, soft key [RESUME] does not appear. It is not possible to go back to the step before the point where soft key [BACK] is pressed.
Status display [RESUMING] is displayed during the guidance that starts by pressing [RESUME].

Change of alarm

When several alarms occur in same time, pressing page key [Page↓]/[Page↑] can select the guidance message.

**18.1.3
Trouble Diagnosis
Monitor Screen**

Trouble Diagnosis Monitor Screen memorizes and displays servo/spindle monitor information for investigating servo/spindle alarm.

Three kinds of data, "Data when the alarm occurs", "Data just before the alarm occurs", "Current data" can be selected and displayed.

Display

Display procedure

- 1 Press function key [Message].
- 2 Press the continuous menu key [>] and press soft key [MONIT].

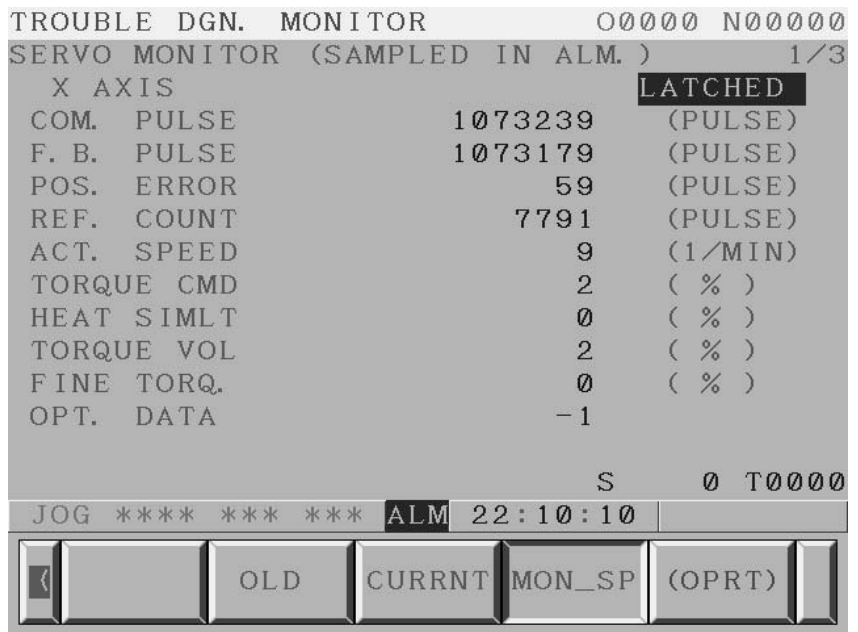

Sample of displaying data of X axis (servo) when the alarm occurred.

Data displayed in Monitor Screen

Displayed data in Monitor screen is showed below.

Display range is the range which can be displayed on screen and not capacity of system.

1) Data of servo motor

Data (Unit)	Data type	Display range	Required parameter
Accumulated command pulse (pulse)	2 Word	± 99999999	
Accumulated feedback pulse (pulse)	2 Word	± 99999999	
Position error (pulse)	2 Word	± 99999999	
Reference counter (pulse)	2 Word	± 99999999	
Actual speed (min ⁻¹)	1 Word	-32768 to +32768	
Command current (%)	1 Word	± 300	
Thermal simulation data (%)	1 Word	0 to 300	
Torque (%)	1 Word	± 300	
Disturbance torque (%) Note 1)	1 Word	± 14564	No.2104 (Cut), No2142 (Rapid)
Optional data Note 2)	1 Word	-32768 to +32767	
Optional data 2 Note 2)	1 Word	-32768 to +32768	
R-phase current (%)	1 Word	± 300	
Effective current (%)	1 Word	± 300	
Pulse coder AMR data	1 Word	0 to 255	
Internal neglect counter	1 Word	0 to +32767	
External neglect counter	1 Word	0 to +32767	
Internal correction counter	1 Word	0 to +32767	
External correction counter	1 Word	0 to +32767	
V-ready off information	1 Word	-32768 to +32768	

NOTE

1 Disturbance torque (%)

Set the following parameters to display the ratio of load torque to unexpected disturbance detection threshold.

- No.2104 (unexpected disturbance detection threshold for cutting)
- No.2142 (unexpected disturbance detection threshold for rapid traverse)

If these parameters are set to 0, load torque is displayed as it is. In this case, ±7282 means the max torque of servo moter.

2 Optional data 1, Optional data 2

Optional data 1 and Optional data 2 are used for maintenance by FANUC serviceman.

2) Data of spindle motor

Data (Unit)	Data type	Display range	Required parameter
Operation mode	Character	*****	
Gear select command	Character	*****	
Command pulse (pulse)	2 Word	± 99999999	
Command speed (min ⁻¹) Note 1)	1 Word	-32768 to +32767	No.4020 (Main)/No.4196 (Sub)
Spindle speed (min ⁻¹)	2 Word	± 99999999	
Motor speed (min ⁻¹) Note 1)	1 Word	-32768 to +32767	No.4020 (Main)/No.4196 (Sub)
Load meter (%)	1 Word	0 to 300	
Position error (pulse)	2 Word	± 99999999	
Synchronization error (pulse)	2 Word	± 99999999	
Input signals	Character	*****	
Output signals	Character	*****	

NOTE

1 Command speed (min⁻¹), Motor speed (min⁻¹)
 Set the following parameters to display Command speed (min⁻¹) and Motor speed.

- No.4020 (Maximum motor speed for Main spindle)
- No.4196 (Maximum motor speed for Sub spindle) (When Spindle switch function is used.)

Operation

Display of Servo monitor data

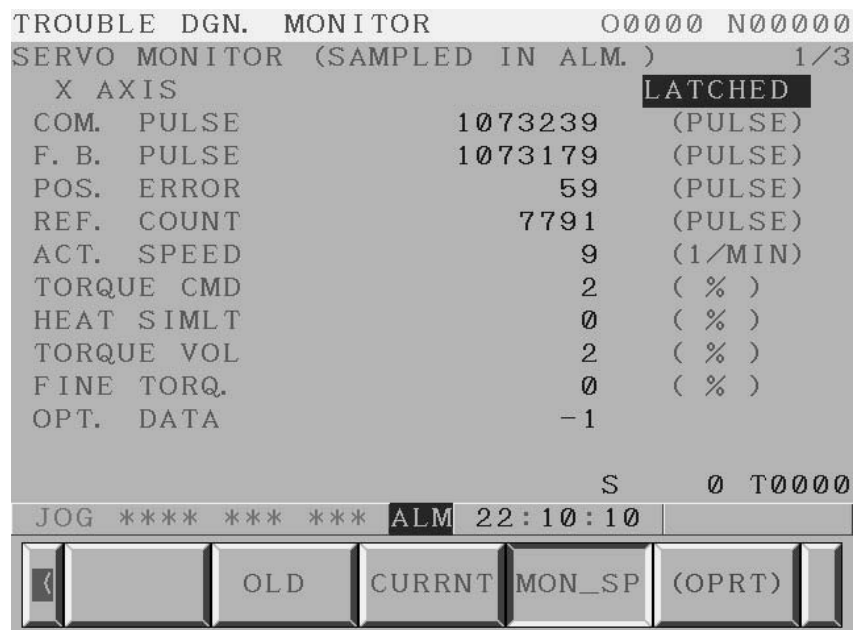

Servo monitor information is switched by pressing soft key [NEW]/[OLD]/[CURRNT].

Soft key [NEW] and [OLD] is displayed alternately.

[NEW]: Data when the alarm occurs

[OLD]: Data just before the alarm occurs

[CURRNT]: Current data

[MON_SP]: Spindle monitor information is displayed.

Display of Spindle monitor information

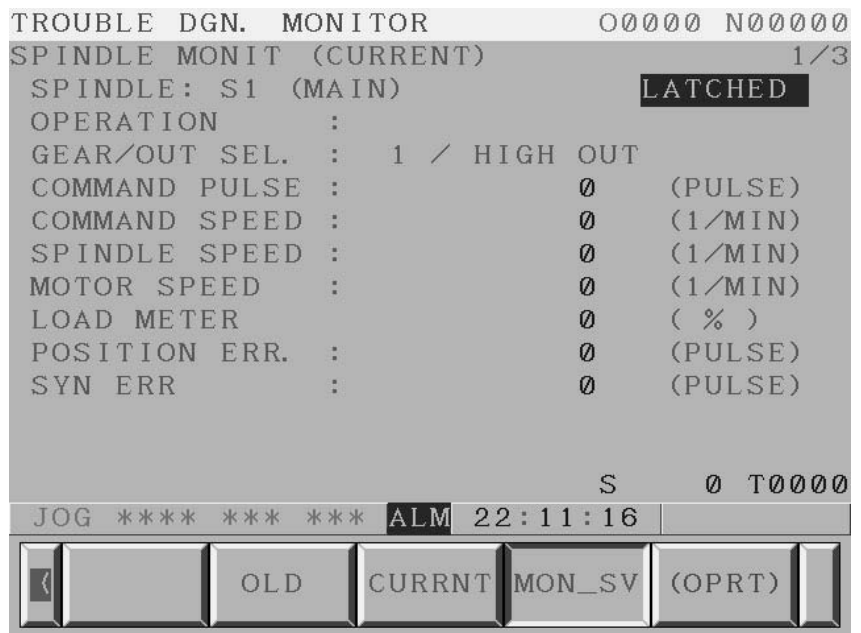

Spindle monitor information is switched by pressing soft key [NEW]/[OLD]/[CURRNT].

Soft key [NEW] and [OLD] is displayed alternately.

[NEW]: Data when the alarm occurs

[OLD]: Data just before the alarm occurs

[CURRNT]: Current data

[MON_SV]: Servo monitor information is displayed.

Change of displayed axis

Displayed axis is switched by pressing cursor key [←]/[→].

Clear of memorized data

Soft key [CLEAR] appears by pressing soft key [(OPER)]. By pressing soft keys [CLEAR] and [EXEC], "Data when the alarm occurs" and "Data just before the alarm occurs" are cleared. And status display "LATCHED" is altered to "SAMPLING".

When servo/spindle alarm occurs in "SAMPLING" status, "Data when the alarm occurs" and "Data just before the alarm occurs" are memorized, and status display "SAMPLING" is altered to "LATCHED".

When clear operation is done in either servo monitor screen or spindle monitor screen, both of servo and spindle information are cleared. And Display data of Trouble Diagnosis Graphic screen is also cleared.

18.1.4 Trouble Diagnosis Parameter Screen

Data type, data unit and trouble forecast level in the trouble diagnosis graphic screen are set in Trouble Diagnosis Parameter Screen.

Display

Display procedure

- 1 Press function key [Message].
- 2 Press the continuous menu key [>] and press soft key [W.GRPH].
- 3 Press soft key [W.PRM].

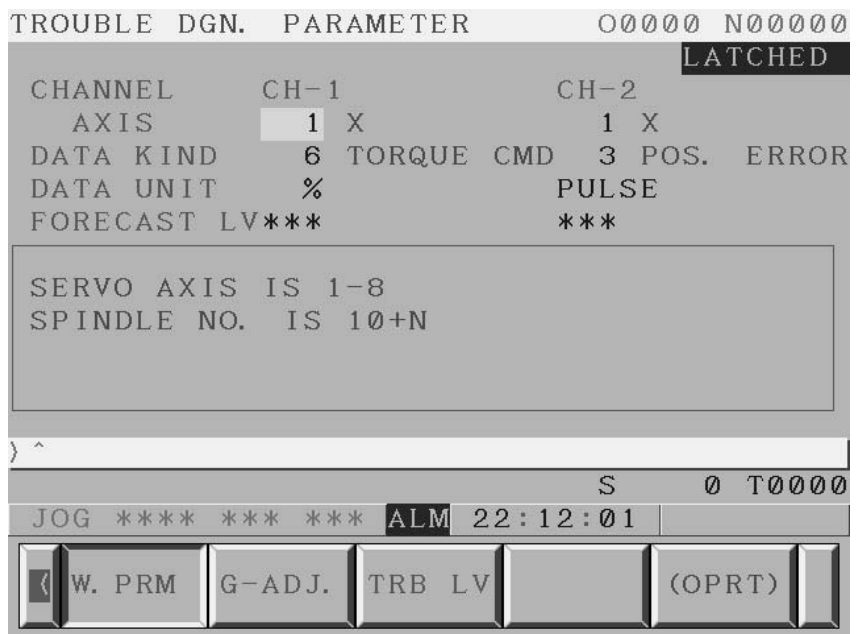

Contents of Display

- AXIS:** AXIS for Waveform display. Manual setting is available. In some cases AXIS data is set automatically for diagnosis in Trouble Diagnosis Guidance Screen.
- DATA KIND:** Data kind for Wave form display. Manual setting is available. In some cases data kind is set automatically for diagnosis in Trouble Diagnosis Guidance Screen.
- DATA UNIT:** Unit of display data. This data is set automatically according to data kind. Manual setting is invalid.
- FORECAST LV:** This data decides boundary value to output Trouble forecast signal. Manual setting is available.

Operation

Data Setting

Move cursor by Cursor key and input number by MDI key and press input key [INPUT] to set data.

AXIS: In case of servo axis, input control axis number.

(Example) Set "1" for first servo axis.

In case of spindle axis, input "10 + spindle number".

(Example) Set "11" for first spindle axis.

DATA KIND: Input data number value according to the following table.

- Data of Servo motor

Data number	Data
1	Accumulated command pulse (pulse)
2	Accumulated feedback pulse (pulse)
3	Position error (pulse)
4	Reference counter (pulse)
5	Actual speed (min^{-1})
6	Command current (%)
7	Thermal simulation data (%)
8	Torque (%)
9	Disturbance torque (%)
10	Optional data
11	R-phase current (%)
12	Effective current (%)
13	Pulse coder AMR data
14	Optional data 2

- Data of Spindle motor

Data number	Data
15	Actual speed (min^{-1})
16	Load meter (%)
17	Position error (pulse)
18	Actual speed (min^{-1}) (80msec)
19	Load meter (%) (80msec)

18.1.5 Trouble Diagnosis Graphic Screen

Servo/spindle data is automatically memorized for several seconds before alarm occurs and display and waveform of data can be displayed in Trouble Diagnosis Graphic Screen.
Maximum 2 kinds of data are displayed in the same time.

Display

Display procedure

- 1 Press function key [Message].
- 2 Press the continuous menu key [>] and press soft key [W.GRPH].
- 3 Press soft key [G-ADJ.].

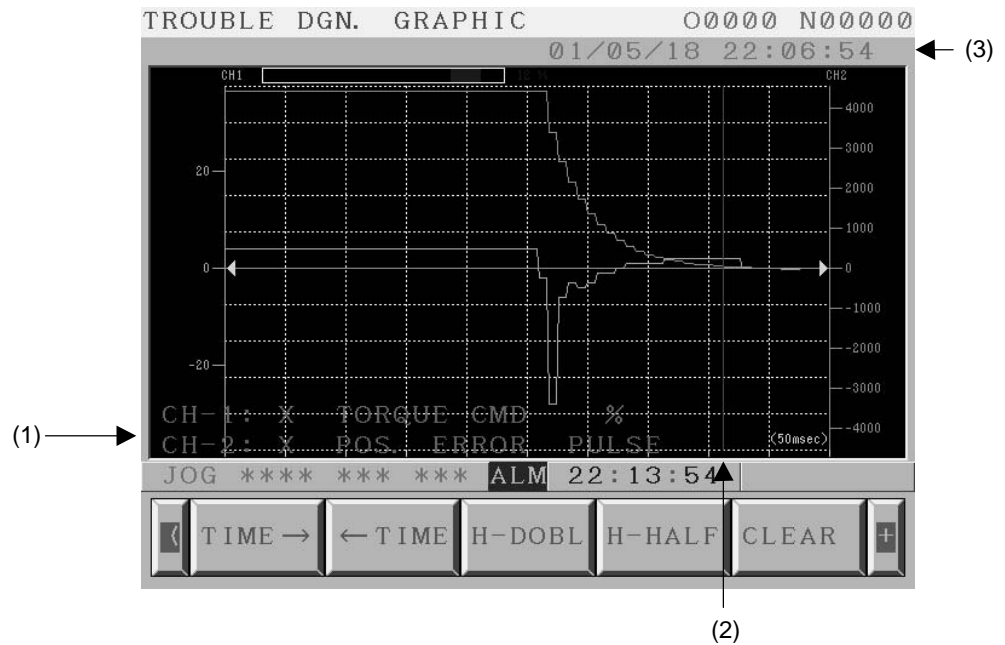

Contents of display

- (1) Contents of displayed waveform:
Channel No. : Axis name Data Kind Data unit
- (2) Red vertical line shows the position (time) of alarm.
- (3) Data and time of alarm

Operation

Change of position and magnification

When Soft key [G-ADJ.] is pressed, the following soft keys appear.

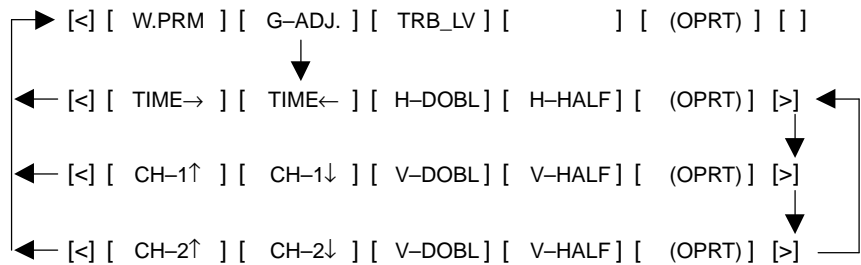

[TIME→]: Shift the waveform rightward.

[TIME←]: Shift the waveform leftward.

[H-DOBL]: Double the time scale of the waveform

[H-HALF]: Half the time scale of the waveform

[V-DOBL]: Double the height scale of the waveform

[V-HALF]: Half the height scale of the waveform

[CH-1↑]: Shift the zero point upward

[CH-1↓]: Shift the zero point downward

[CH-2↑]: Shift the zero point upward

[CH-2↓]: Shift the zero point downward

The time scale is a common scale for the channel 1 and 2.

The position and magnification of the height scale can be set for each channel.

18.1.6 Trouble Forecast Level Setting Screen (Only for Servo Axis)

Trouble forecast level is set in this screen.
Two trouble forecast levels, thermal simulation and disturbance torque, can be set.

Display

Display procedure

- 1 Press function key <Message>.
- 2 Press the continuous menu key [>] and press soft key [W.GRPH].
- 3 Press soft key [TRB LV].

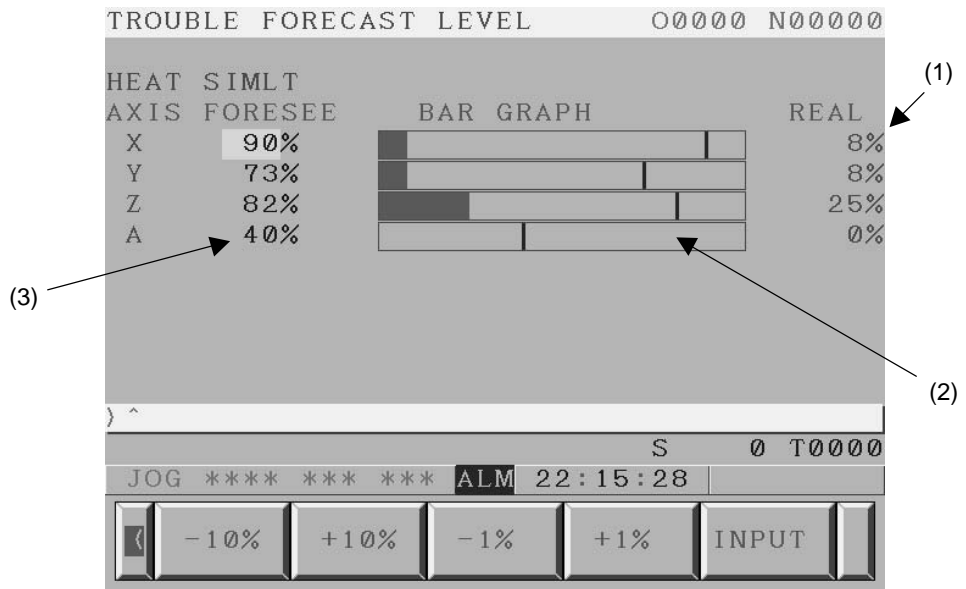

Contents of display

- (1) Current value of thermal simulation/disturbance torque is displayed with sign.
- (2) Current value of thermal simulation or disturbance torque is displayed by bar graphic.
Light Blue part: Current value of thermal simulation/disturbance torque.
Red part: Trouble forecast level.
- (3) Trouble forecast level.

Operation

Setting Trouble forecast level

- 1 Select thermal simulation or disturbance torque by page keys [Page↑]/[Page↓].
 - 2 Select axis by cursor keys [↑]/[↓].
 - 3 Input numerical value by MDI key and press [INPUT] key.
- Trouble forecast level is input into parameter No.8860 and 8861.

Change of Trouble forecast level

When Soft key [TRB LV] is pressed, the following soft keys appear.

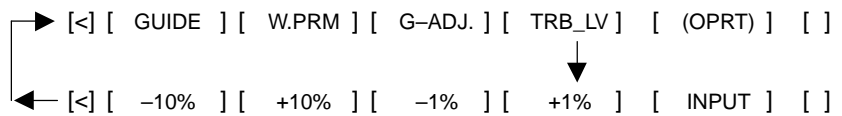

- [-10%]: Subtract 10% from Trouble forecast level.
- [+10%]: Add 10% to Trouble forecast level.
- [-1%]: Subtract 1% from Trouble forecast level.
- [+1%]: Add 1% to Trouble forecast level.
- [INPUT]: Input Trouble forecast level by MDI key.

Trouble forecast signal

When thermal simulation or disturbance torque of servo axis exceeds trouble forecast level, Trouble forecast signal TDFx (F298.0 – F298.3) is output.

Parameters TSx/TRx (No.8853/8854) need to be set to 1 to perform the trouble forecast.

Parameter

	#7	#6	#5	#4	#3	#2	#1	#0
8850								MDG

[Data type] Bit

MDG Trouble diagnosis function is:
 0 : Available.
 1 : Not available.

	#7	#6	#5	#4	#3	#2	#1	#0
8853	TS8	TS7	TS6	TS5	TS4	TS3	TS2	TS1

[Data type] Bit

TS1 to TS8 For thermal simulation data of the servo axis, trouble forecast is:
 0 : Not performed.
 1 : Performed.

	#7	#6	#5	#4	#3	#2	#1	#0
8854	TR8	TR7	TR6	TR5	TR4	TR3	TR2	TR1

[Data type] Bit

TR1 to TR8 For the disturbance torque value of the servo axis, trouble forecast is:
 0 : Not performed.
 1 : Performed.

8860	Trouble forecast level for thermal simulation
8861	Trouble forecast level for disturbance torque

[Data type] WORD AXIS

[Unit of data] %

[Valid data range] 0 to 100%

	#7	#6	#5	#4	#3	#2	#1	#0
13110								JPN

NOTE

When this parameter is set, the power must be turned off before operation is continued.

[Data type] Bit

JPN As the display language used for trouble diagnosis and machine alarm diagnosis:

0 : English has precedence.

For machine alarm diagnosis, the GUIE_USR.MEM file has precedence.

1 : Japanese has precedence.

For machine alarm diagnosis, the GUIJ_USR.MEM file has precedence.

Signal

Trouble forecast signal

TDF1 to TDF8

<F0298#0 to #7>

[Classification] Output signal

[Output condition] When thermal simulation or disturbance torque of servo axis exceeds the trouble forecast level, TDFSVx turn to 1.

Signal address

	#7	#6	#5	#4	#3	#2	#1	#0
F298	TDF8	TDF7	TDF6	TDF5	TDF4	TDF3	TDF2	TDF1

18.2 MACHINE ALARM DIAGNOSIS

18.2.1 Outline

Machine alarms (External alarm message and Macro alarm) can be diagnosed on the trouble diagnosis guidance screen in addition to CNC alarms.



Example of a trouble diagnosis guidance screen

Kind of diagnosed alarms

The following alarms can be diagnosed.

- 1 External alarm message (Alarm No.1000–1999)
- 2 Macro alarm (#3000) (Alarm No.3000–3200)

NOTE

Option functions are separately needed to use the above alarms.

Required environment

The following environment is needed to make the data which is displayed on the trouble diagnosis guidance screen.

- 1 Microsoft® Excel 97 or later version
- 2 MS-DOS® (Command prompt of Microsoft® Windows® is available.)
- 3 A personal computer included an operating system (OS) on which the above application can be executed.

Microsoft, Windows, MS-DOS are registered trademarks of Microsoft Corporation of the USA. Microsoft Excel 97 is a product whose copyright is owned by Microsoft Corporation of the USA.

18.2.2 Making Guidance Tables

Guidance tables for diagnosis of machine alarms are made by using an Excel sheet which is provided by FANUC. Making procedure of guidance tables is as follows.

- 1 Making a guidance table (1) (Using Excel)
- 2 Making a guidance table (2) (Using Excel)
- 3 Converting an Excel sheet to a memory card file. (Using Excel and MS-DOS command)

Input items and a trouble diagnosis guidance display

Input items on guidance table (1)

- Classified code
- Alarm message
- Probable cause

Input items on guidance table (2)

- Guidance message

TROUBLE DGN. GUIDANCE 00000 N00000

M -1000 01/01

Machine alarm 1000

PROBABLE CAUSE:

1. Failure of ATC
2. Tool is broken
3. Shortage of coolant

GUIDANCE:

Is amount of coolant enough?

LATCHED

S 0 T0000

MDI STOP *** ** ALM 10:42:57

YES NO BACK

Making a guidance table (1)

Alarm No., Classified code, Alarm message, Probable cause and etc. are registered into a guidance table (1).

[Guidance Table (1)]									
	CHECK	>	10	Add lines		Convert			
No.	Alarm No.	Classified code		Alarm message	Probable cause			Message ID	(Reserved)
		Code 1	Code 2		Line 1	Line 2	Line 3		
1									
2									
3									

(a)
(b)
(c)
(d)
(e)
(f)

Input items

- (a) Alarm No.
 - Input alarm numbers of the external alarm message or the macro alarm.
 - Max 5 figures (Range: 0-65535).
 - Ex.) In case of the external alarm message alarm No.1000
"1000"
 - (b) Classified code
 - Two codes (Code 1 and Code 2) are available.
 - These codes are displayed at 1st line on the trouble diagnosis guidance screen as "[Code 1] - [Code 2]".
 - Code 1
 - Input the type of the alarm and so on.
 - Max 2 characters.
- CAUTION**
A character string "NC" is reserved as the code 1 of CNC alarm. Do not use "NC" as the code 1.
- Code 2
 - Input the alarm No. and so on.
 - Max 16 characters.
 - (c) Alarm message
 - Max 32 characters * 1 line.
 - It is displayed at 2nd line on the trouble diagnosis guidance screen.
 - (d) Probable cause
 - Max 32 characters * Max 3 lines.
 - It is displayed at the part of "PROBABLE CAUSE" on the trouble diagnosis guidance screen.
 - (e) Message ID
 - A Message ID specifies a guidance message which should be displayed at first when an alarm occurs.
 - Max 6 characters with capital letters.
 - Ex.) In case of the first guidance message for the external alarm message alarm No.1000
"1000A"
 - Please refer to "2.2 Making a guidance table (2)" about the message ID and the guidance message.
 - (f) (Reserved)
 - Please input nothing at this item.

Operation of buttons

- [Check] button
 When [CheckECK] button is pushed, a range of number, a number of characters and invalid character codes are checked.
 Alarm numbers are checked if they are within 0–65535. But alarm numbers in the external alarm message and the macro alarm are actually available.
 If the result is OK, a string of the cell under the button is changed from "Unchecked" to "OK". If the result is NG, the string is changed to "NG". And the cell color becomes green. And a comment, which can display the cause of error, is added to the cell.

Ex.)

CHECK	
Unchecked	
No.	Alarm No.
1	1000
2	1001

CHECK	
OK	
No.	Alarm No.
1	1000
2	1001

CHECK		>	10	Add lines
NG				
No.	Alarm No.	Classified code		
		Code 1		Code 2
1	1000			
2	123456			
3				
4				
5				
6				

Out of range.
(0 - 65535)

- [Add lines] button
 Please push [Add lines] button in order to increase the number of alarms.
 The number is specified in a cell on the left side of the button.
- [Convert] button
 When [Convert] button is pushed, both guidance tables (1) and (2) on the Excel sheet are converted to the text type data.
 Please refer to "2.3 Converting from an Excel file to a memory card file."
- [>] button
 WhenECK [>] ECKbutton is pushed, the guidance table (2) is displayed.

Making a guidance table (2)

”Guidance message” is registered into a guidance table (2). ”Guidance message” is a question and an instruction to an operator.

[Guidance Table (2)]					
← CHECK		10	Add lines		
OK					
No.	Message ID	Guidance message	Next message ID		Comment
			YES	NO	
1					
2					
3					

(a)
(b)
(c)
(d)

Input items

(a) Message ID

A Message ID specifies a guidance message.
 Max 6 characters with capital letters.

Ex.) In case of the first message for the external alarm message alarm No.1000
 ”1000A”

Ex.) In case of the second message for the external alarm message alarm No.1000
 ”1000B”

CAUTION

Message IDs starting with ”M” are reserved for a jump to MTB’s guidance table from a CNC guidance table.

Ex.) ”M205”, ”M407”

Do not use a message ID starting with ”M” for the other purpose.

Please refer to Item ”Jump from CNC guidance table to MTB’s guidance table”.

(b) Guidance message

Write a question, an instruction and so on to operators.
 Max 32 characters * Max 4 lines.

It is displayed at the part of ”GUIDANCE” on the trouble diagnosis guidance screen.

- If 32 characters are displayed in one line, the next character is automatically displayed in a new line.
- If a new line is required on purpose, write ”\n”. ”\n” is not counted in the number of characters.
- The total number of lines must be within 4 lines.

(c) Next message ID

Next message ID specifies a guidance message which is displayed after an operator pushes a soft-key [YES]/[NO] to answer a question.
 Max 6 characters with capital letters.

- Input ”-1” when there is no next message ID to display after a soft-key [YES]/[NO] is pushed.

- Input "-1" for both YES and NO in case of the end of a diagnosis.

(d)Notes

It is possible to write some notes here.

Operation of buttons

- [Check] button
When [Check] button is pushed, a range of number, a number of characters and invalid character codes are checked.
If the result is OK, a string of the cell under the button is changed from "Unchecked" to "OK". If the result is NG, the string is changed to "NG". And the cell color becomes green. And a comment, which can display the cause of error, is added to the cell.

Ex.)

←	CHECK	←	CHECK
	Unchecked		OK
No.	Message ID	No.	Message ID
1	1000A	1	1000A
2	1000B	2	1000B

←	CHECK	10	Add lines
	NG		
No.	Message ID	Guidance me	
1	1000A	<div style="border: 1px solid black; padding: 5px;"> The maximum number of characters is 6. </div>	
2	123456A		
3			
4			
5			
6			

And when a message ID starting with "M" is found the cell color becomes sky blue.

Ex.)

No.	Message ID
1	1000A
2	1000B
3	M205

- [Add lines] button
Please push [Add lines] button in order to increase the number of the guidance messages.
The number is specified in a cell on the left side of the button.
- [←] button
When [←] button is pushed, the guidance table (1) is displayed.

Converting an Excel sheet to a memory card file

A procedure of conversion

Guidance tables on an Excel sheet is need to be converted to a memory card file which CNC can reads. A procedure of conversion is as follows.

- (1) Finish to making both guidance tables (1) and (2), and then push [Convert] button on a guidance table (1).
 - In PC, a sub folder (directory) named "GUIDEDAT" is made in the folder where an Excel sheet is installed. And text type files are made in this sub folder.
- (2) Execute "TXT2MEM.BAT" at MS-DOS prompt. "TXT2MEM.BAT" is also installed in the same folder as an Excel sheet.

Ex.) In case that an Excel sheet is installed in a folder "D:\FLOW\"
Type "TXT2MEM" and push an enter key.

```
D:\FLOW>TXT2MEM[Enter]
```

- (3) A file named "GUIE_USR.MEM" (for English) or "GUIJ_USR.MEM" (for Japanese) is made in the same folder as an Excel sheet.
- (4) Load "GUIE_USR.MEM" or "GUIJ_USR.MEM" into a CNC via a memory card by the boot function. Then it is possible to diagnose the machine alarms.

It is possible to load both of "GUIE_USR.MEM" and "GUIJ_USR.MEM". In this case one of them can be selected by a parameter JPN (No.13110#0). When this parameter is set, power must be powered off.

When only one of them is loaded, loaded file is available irrespective of a parameter JPN (No.13110#0).

Jump from CNC guidance table to MTB's guidance table

As a result of CNC alarm diagnosis, the alarm may be caused by machine trouble.

Considering such a case, it is possible to jump to MTB's guidance table from CNC guidance table by the special message IDs starting with "M". If the flowing special message IDs stating with "M" are created in MTB's guidance table, a jump to MTB's guidance table from CNC guidance table becomes available.

Reserved message IDs

No.	Message ID	Alarm name	Presumed cause
1	M205	Rigid mode DI OFF	The rigid mode DI signal (G061.0) is not set to 1 when the rigid tapping is executed.
2	M409	Abnormal load detected	A mechanical collision or twist occurred, resulting in a load torque higher than a normal operation value.
3	M410	Excessive stop error	A mechanical collision or twist occurred, disabling an axis from reaching a target position.
4	M411	Excessive move error	A mechanical collision or twist occurred, disabling an axis from moving.
5	M420	Excessive torque difference	Two axes to be moved synchronously lost mechanical synchronism with each other, resulting in a large torque difference.
6	M421	Excessive semi-closed loop error	With a closed-loop machine, a shift occurred between the motion of the motor and the motion of the separate detector for a cause such as a mechanical twist.
7	M436	OVC alarm	A mechanical collision or twist occurred, resulting in a large load and the flow of an excessive current.

CAUTION

All message IDs starting with "M" are reserved for a jump to MTB's guidance table from a CNC guidance table. In the future, a message ID to which a jump is made from a CNC guidance table may be added. So, do not use a message ID starting with "M" which may or may not be included in the table above for the other purpose.

Parameter

	#7	#6	#5	#4	#3	#2	#1	#0
13110								JPN

[Data type] Bit

JPN Language used in the trouble diagnosis and the machine alarm diagnosis

0 : English is prior.

In case of the machine alarm diagnosis, a file "GUIE_USR.MEM" is prior.

1 : Japanese is prior.

In case of the machine alarm diagnosis, a file "GUIJ_USR.MEM" is prior.

NOTE

When this parameter is set, power must be turned off before operation is continued.

Caution

- 1 This function is an option function.
- 2 Equipment for making the guidance tables (Microsoft Excel and a personal computer with an operating system (OS) and so on) is separately needed.

18.3

αi SERVO WARNING INTERFACE

General

The *αi* servo system can report the warning status before one of the following target alarms occurs.

When the warning status is entered, a report to the PMC is issued.

For example, this signal can be used by the machine for retracting tools from the time a warning occurs by the time a servo alarm occurs.

Signal

Servo warning detail signals SVWRN1 to 4 <F093#4 to #7>

[Classification] Output signal

[Function] Reports the warning signal corresponding to the state of the servo amplifier.

[Output condition] The following table shows the warning statuses of the servo amplifier and their corresponding warning signals.

Corresponding alarm messages	Warning status signals (F93)				Time from when a warning state signal is issued to until an alarm occurs
	SVWRN4 (#7)	SVWRN3 (#6)	SVWRN2 (#5)	SVWRN1 (#4)	
444 n AXIS: INV. COOLING FAN FAILURE	1	0	0	0	One minute
601 n AXIS: INV. RADIATOR FAN FAILURE	1	0	0	1	Until overheat occurs (inconstant)
443 n AXIS: CNV. COOLING FAN FAILURE	1	1	0	0	One minute
606 n AXIS: CNV. RADIATOR FAN FAILURE	1	1	0	1	Until overheat occurs (inconstant)
431 n AXIS: CNV. OVERLOAD	1	1	1	0	One minute
607 n AXIS: CNV. SINGLE PHASE FAILURE	1	1	1	1	PSMR: Five seconds, PSM: One minute

A timing chart for handling a warning is shown below.

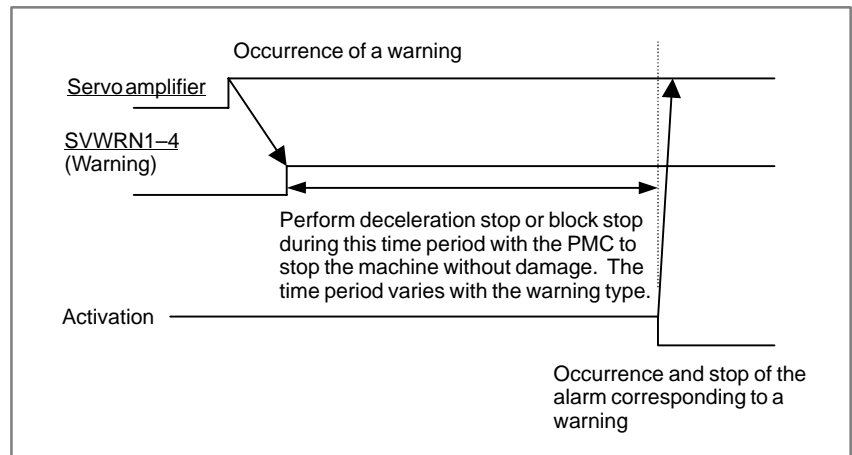

Signal address

	#7	#6	#5	#4	#3	#2	#1	#0
F903	SVWRN4	SVWRN3	SVWRN2	SVWRN1				

18.4 WARNING INTERFACE FOR THE *αi* SPINDLE

Overview

For the *αi* spindle, the warning state can be reported before an alarm is issued. When the warning state is entered, a report to the PMC is sent. For example, this signal can be used for retracting tools or reducing cutting load from the time a warning occurs by the time an overheat alarm occurs. In addition, diagnostic information also contains warning numbers.

Signal

Spindle warning detailed signals SPWRN1 to 9 <F264#0 to #7, F265#0>

[Classification] Output

[Function] Reports the warning number corresponding to the state of the *αi* spindle amplifier.

[Output condition] When the *αi* spindle is in the warning state, a warning number consisting of SPWRN1 to SPWRN9 is output as nine-bit binary data. If warnings occurred on multiple *αi* spindle amplifiers, the warning number of the *αi* spindle having the smallest axis number is output. However, when there is no *αi* spindle or the system configuration of the spindle includes an additional spindle that is older than the *αi* spindle, this function is invalid for all spindles. The warning numbers and their descriptions are shown below.

Warning number	Contents	Details
56	Internal fan stopped	If the internal fan stops, the warning signal is output. Since the spindle continues to operate at this time, use the PMC to perform processing as needed. About one minute after the warning signal is output, an alarm occurs.
88	Radiator cooling fan stopped	If the radiator cooling fan stops, the warning signal is output. Since the spindle continues to operate at this time, use the PMC to perform processing as needed. If the main circuit overheats, an alarm occurs.
04	Open-phase detected in the converter main power supply	If an open-phase is detected in the main power supply, the warning signal is output. Since the spindle continues to operate at this time, use the PMC to perform processing as needed. About one minute (for the PSM) or about five seconds (for the PSMR) after the warning signal is output, an alarm occurs.

Warning number	Contents	Details
58	Converter main circuit overloaded	If the main circuit of the PSM is overloaded, the warning signal is output. Since the spindle continues to operate at this time, use the PMC to perform processing as needed. About one minute after the warning signal is output, an alarm occurs.
59	Converter cooling fan stopped	If the PSM cooling fan stops, the warning signal is output. Since the spindle continues to operate at this time, use the PMC to perform processing as needed. About one minute after the warning signal is output, an alarm occurs.
113	Converter radiator cooling fan stopped	If the PSM radiator cooling fan stops, the warning signal is output. Since the spindle continues to operate at this time, use the PMC to perform processing as needed. If the PSM main circuit overheats, an alarm occurs.

Signal address

	#7	#6	#5	#4	#3	#2	#1	#0
F264	SPWRN8	SPWRN7	SPWRN6	SPWRN5	SPWRN4	SPWRN3	SPWRN2	SPWRN1
F265								SPWRN9

Diagnosis screen

The status of a warning is displayed on the following diagnostic screen.

712	Warning status of first spindle
713	Warning status of second spindle
732	Warning status of third spindle
733	Warning status of fourth spindle

The number of a warning caused on each spindle is indicated.
If there is no warning, 0 is indicated.

NOTE

NOTE

- 1 For spindles that are older than the αi spindle, this function is invalid.
- 2 When the system configuration of the spindle (even another spindle) includes an additional spindle that is older than the αi spindle, this function is invalid.

19 INTERFACES RELATED TO Series 20i MACRO

The following diagram shows the relationships between interface signals used among the CNC, PMC, and MACRO when a machining guidance function is implemented using the CNC macro executor.

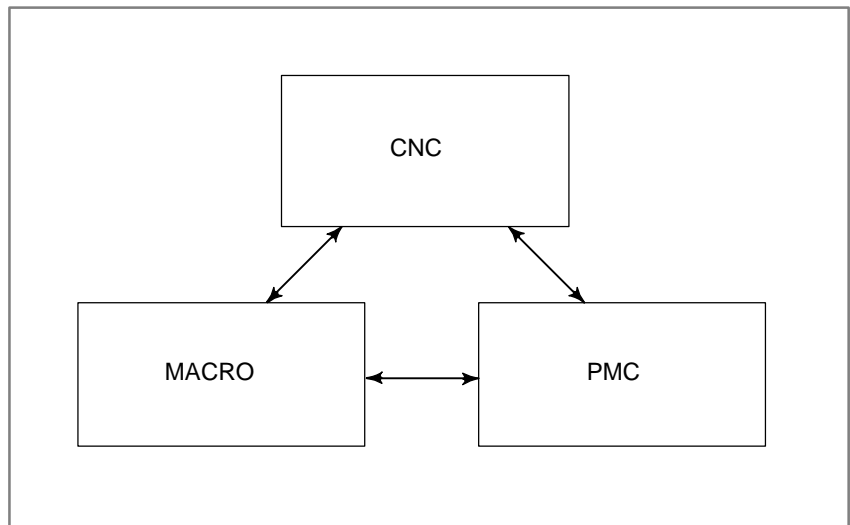

Part of the R area in the PMC is used as addresses for signals related to MACRO.

19.1 SIGNALS USED BY MACHINING GUIDANCE FUNCTION (20i-F/T)

PMC → MACRO

Coordinate origin

Datum plane setup signals

First-axis datum plane setup signal

ORG1: Specifies a datum plane with the origin (0) set at the current value of the first axis.

Second-axis datum plane setup signal

ORG2: Specifies a datum plane with the origin (0) set at the current value of the second axis.

Third-axis datum plane setup signal

ORG3: Specifies a datum plane with the origin (0) set at the current value of the third axis (for the F series only).

The first, second, and third axes correspond to the X-, Y-, and Z-axes (20i-F) or the X- and Z-axes (20i-T), respectively. The above signals are active when they are 1.

Using a datum plane setup signal requires that bit 5 of parameter No. 1201 (AWK) be set to 1 (for the F series only).

	#7	#6	#5	#4	#3	#2	#1	#0
R950						ORG3	ORG2	ORG1

Data setup

Data setup signal

Data setup signal

DEST: When this signal is 1, it reads data about the current position of the axis specified on the data entry screen and sets it as an entry item.

	#7	#6	#5	#4	#3	#2	#1	#0
R951								DEST

Signals related to automatic operation

Machining guidance menu select signals

	#7	#6	#5	#4	#3	#2	#1	#0
R952				GMN4	GMN3	GMN2	GMN1	GMN0

Machining guidance menu select signal					Machining guidance menu to be selected	
GMN4	GMN3	GMN2	GMN1	GMN0	F	T
0	0	0	0	0	Not selected (machining guidance menu-based machining is not performed)	
0	0	0	0	1	Linear machining	Linear machining
0	0	0	1	0	Circular machining	Circular machining
0	0	0	1	1	Corner machining	Corner machining
0	0	1	0	0	Pocketing	Roughing
0	0	1	0	1	Pattern positioning	Threading
0	0	1	1	0	Facing	Grooving
0	0	1	1	1	Side cutting	Hole making
0	1	0	0	0	Limit machining	—
0	1	0	0	1	Roughing	—
0	1	0	1	0	Hole making	—

Constant surface speed function (T series only)

Spindle stop S05: When this signal is 1, it outputs a spindle stop command (M05).

Spindle reverse rotation S04: When this signal is 1, it outputs a spindle reverse rotation command (M04).

Spindle normal rotation S03: When this signal is 1, it outputs a spindle normal rotation command (M03).

NOTE

For the 20i-F, setting bit 6 of parameter No. 9323 (SFN) to 1 enables an S command (spindle rotation speed) to be output together with the spindle normal/reverse rotation command.

A value set in machining guidance-common parameter No. 6 is used as the spindle speed.

Feed-per-minute specification

FMIN: When this signal is 1, it puts the machine tool in the feed-per-minute mode.

Feed-per-revolution specification

FREV: When this signal is 1, it puts the machine tool in the feed-per-revolution mode.

Constant surface speed function disable

CSF: When this signal is 1, it disables the constant surface speed function.

Constant surface speed function enable

CSN: When this signal is 1, it enables the constant surface speed function.

	#7	#6	#5	#4	#3	#2	#1	#0
R956	S05	S04	S03		FMIN	FREV	CSF	CSN

Timing of constant surface speed, spindle start, stop signals

The following descriptions use the timing chart shown below as an example.

- (1) When the constant surface speed function enable button is pressed, the PMC sets the CSN signal (bit 0 of R956) to 1 to request MACRO to put the machine tool in the constant surface speed mode.
- (2) When the CSN becomes 1, MACRO sets the SSCE signal (bit 1 of R957) to 1 to put the machine tool in the constant surface speed mode.
- (3) When the SSCE signal becomes 1, the PMC resets the CSN to 0.
- (4) When the CSN becomes 0, MACRO resets the SSCE to 0 to terminate the sequence. This timing chart applies also to the constant surface speed function disable (CSF) signal, spindle normal rotation (S03), spindle reverse rotation (S04), and spindle stop (S05) commands (bits 1, 5, 6, and 7 of R956).

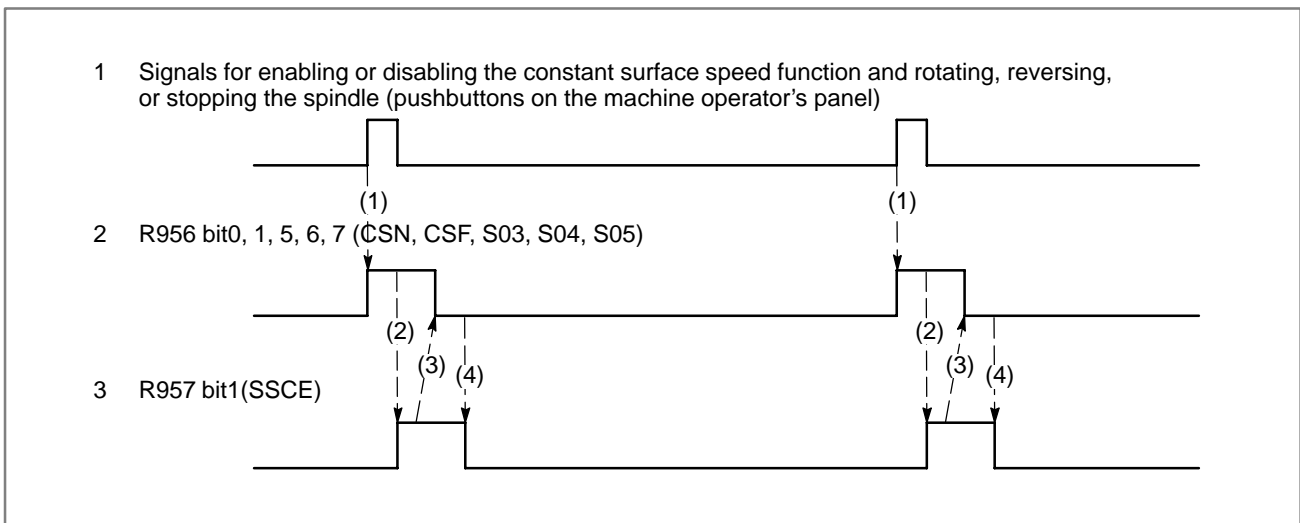

Timing of signals for specifying feed per minute and feed per revolution

The following descriptions use the timing chart shown below as an example.

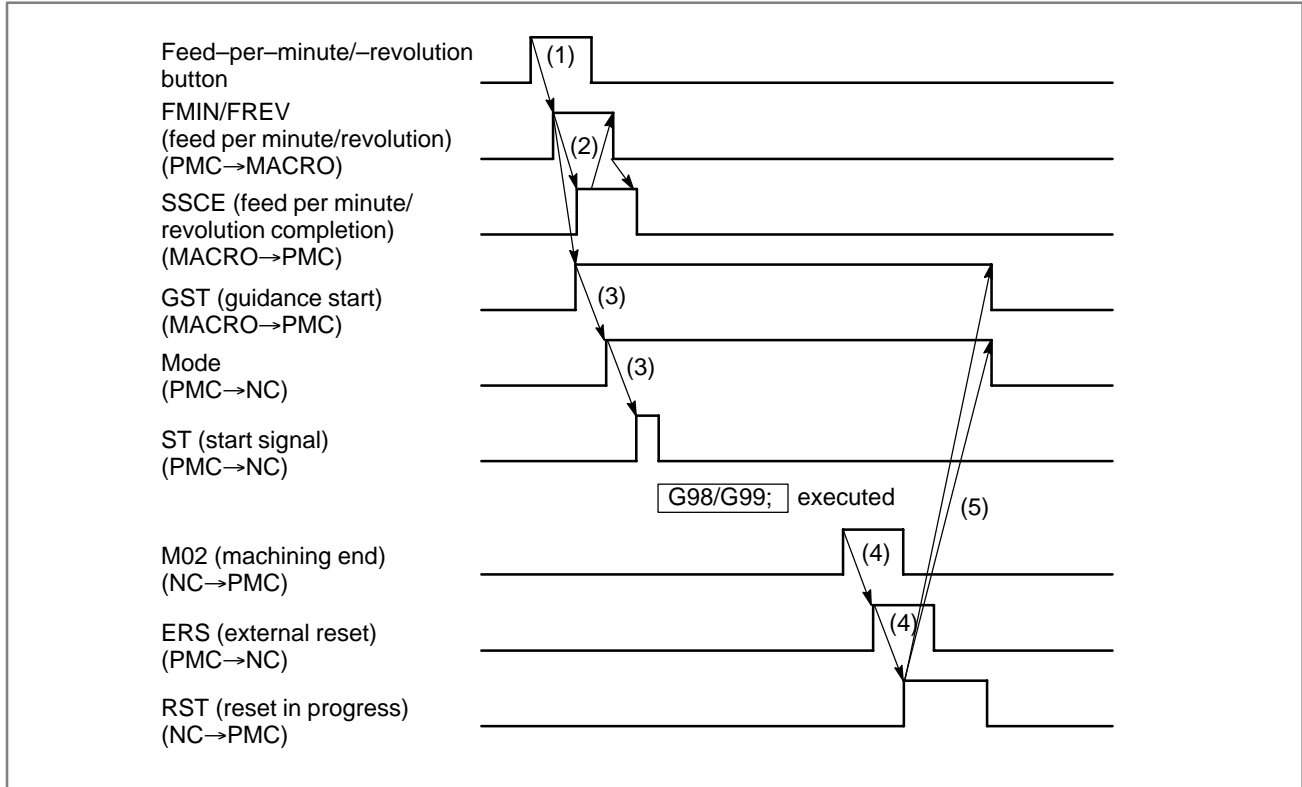

- (1) When the feed-per-minute/-revolution button is pressed, the PMC sets the FMIN/FREV signal to 1 to request MACRO to make preparation for feed-per-minute/-revolution mode switching.
- (2) When the FMIN/FREV signal becomes 1, MACRO sets the SSCE and GST signals to 1. When the SSCE signal becomes 1, the PMC resets the FMIN/FREV signal to 0. When the FMIN/FREV signal becomes 0, MACRO resets the SSCE signal to 0 to deselect the feed-per-minute/-revolution feed mode.
- (3) When the GST signal becomes 1, the PMC enters the MEM mode and turns on the start signal ST, thus causing the feed-per-minute/-revolution command (G98/G99;) to be executed.
- (4) When the feed-per-minute/-revolution command ends, the NC outputs M02, causing the PMC to reset the external reset signal ERS to 0 for causing a reset.
- (5) When a reset occurs, the PMC returns from the MEM mode to the previous mode, and MACRO resets the GST signal to 0.

Teaching/playback function

Teaching (cutting) TCH: When this signal is 1, it registers a cutting operation that is supposed to end at the current position in memory.

Teaching (rapid traverse) RCH: When this signal is 1, it registers a rapid traverse operation that is supposed to end at the current position in memory.

Playback PLB: This signal causes a taught machining operation to be repeated.

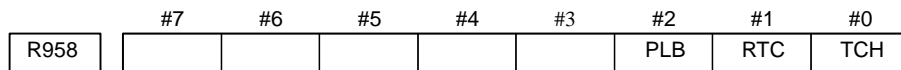

Timing of signals for teaching

The following descriptions use the timing chart shown below as an example.

- (1) When the teaching button is pressed, the PMC sets the TCH or RTC (bit 0 or 1 of R956) to 1 to request MACRO to perform teaching. At the same time, it turns on the axis interlock signal *IT to disable axis shift during teaching by MACRO.
- (2) When the TCH/RTC becomes 1, MACRO fetches teaching data and stores it in memory, then sets the TCE (bit 0 of R957) to 1.
- (3) When the TCE becomes 1, the PMC resets the TCH/RTC to 0 to release axis interlock.
- (4) When the TCH/RTC becomes 0, MACRO resets the TCE to 0 to terminate this sequence. This timing chart applies also to M codes M03, M04, M05, M06, M08, and M09 (bits 2, 3, 4, 5, 6, and 7 of R959).

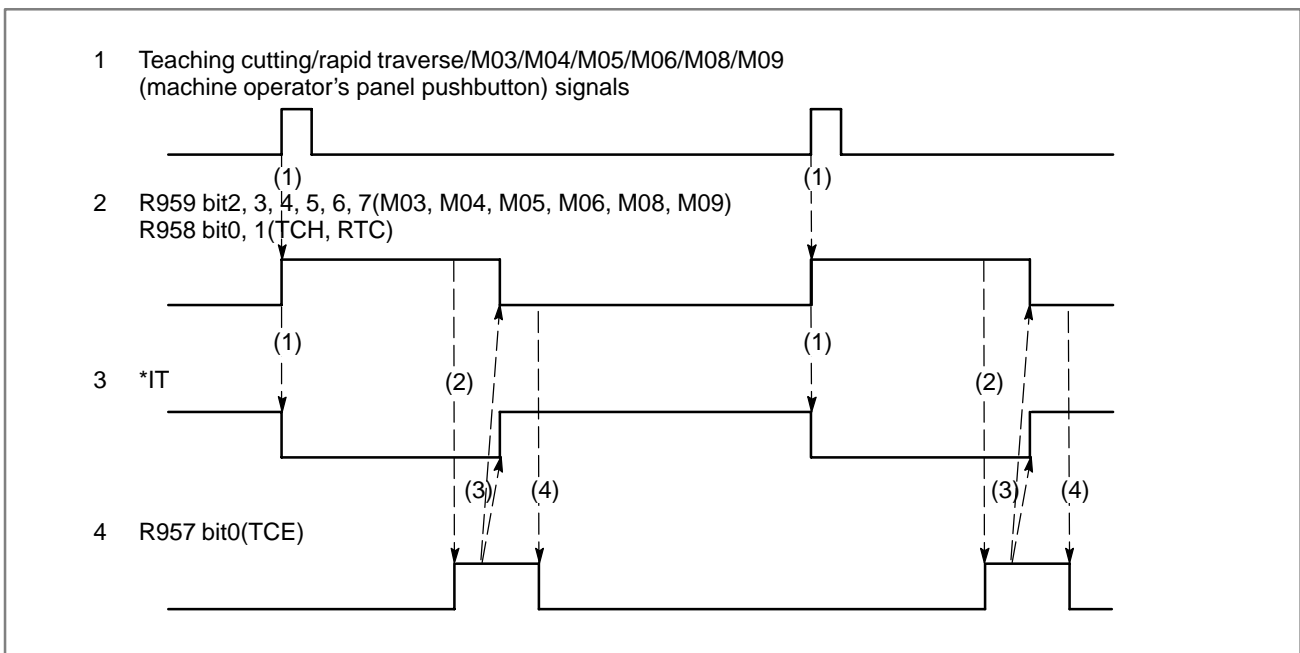

Playback signal timing

The following descriptions use the timing chart shown below as an example.

- (1) When the playback button is pressed, the PMC sets the PLB signal to 1 to request MACRO to make preparation for playback execution.
- (2) When the PLB signal becomes 1, MACRO sets the GST signal to 1 after finishing preparation for playback.
- (3) When the GST signal becomes 1, the PMC enters the MEM mode and turns on the start signal ST, thus starting playback machining.
- (4) When machining ends, the NC outputs M02, so the PMC sets the external reset signal ERS to 1 for causing a reset.
- (5) When a reset occurs, the PMC resets the PLB signal to 0, and MACRO resets the GST signal to 0, thus terminating playback.

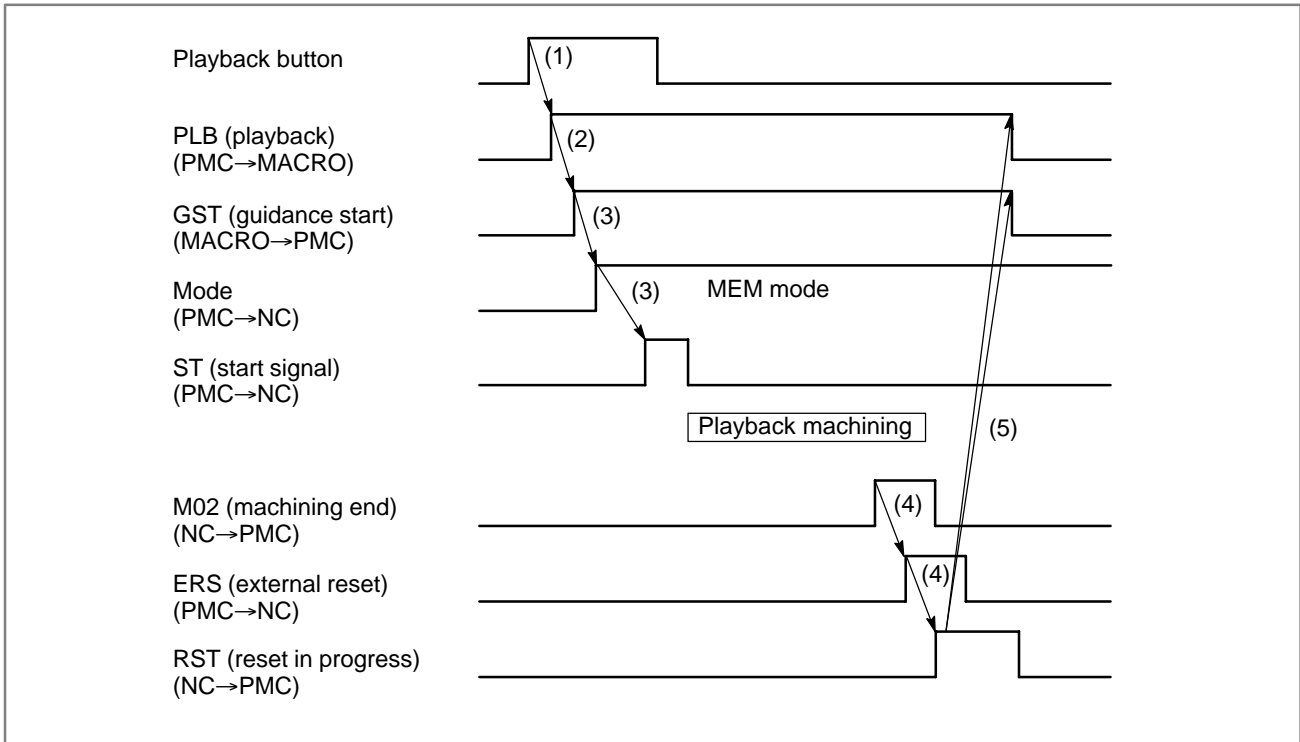

M code teaching

M code teaching M03 to M06, M08, and M09:

When these signals are 1, they save M codes in memory.

	#7	#6	#5	#4	#3	#2	#1	#0
R959	M09	M08	M06	M05	M04	M03		

MACRO → CNCMachining data setup signals

These signals are used for manual handle/jog feed (linear/circular feed).

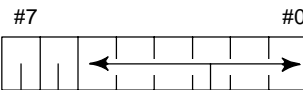
Address	Size	Linear feed	Circular feed
R961	1 byte	0: Neither linear nor circular feed is performed. 1: Linear feed 2: Circular feed (clockwise) 3: Circular feed (counterclockwise)	
R962 to R965	4 bytes	X-axis approach direction	X-axis coordinate for circle center position (X0)
R966 to R969	4 bytes	Y axis approach direction	Y axis coordinate for circle center position (Y0)
R970 to R973	4 bytes	Distance from the origin to the line (P)	Circle radius (R)
R974	1 byte	Travel direction when the guidance handle is rotated forward 0: +90 degrees with the approach direction 1: -90 degrees with the approach direction	0: Machining inside the circle 1: Machining outside the circle
R975	1 byte	 <p>Reset these bits to 0.</p> <p>Specify a forbidden area if the limit function is enabled.</p> <p>0: The forbidden area is in the same direction as the approach direction. 1: The forbidden area is in the direction opposite to the approach direction.</p> <p>Specify whether to enable the limit function.</p> <p>0: Disable 1: Enable</p>	
R979	1 byte	Setup change notification	

- If neither linear nor circular feed is to be performed, reset R961 to 0. R962 to R974 may be set to any value, however.
- The setup change notification signal (R979) indicates to the NC that data for linear or circular feed has been changed.

The procedure for this follows:

- 1 Set data at R961 to R 974.
- 2 After setting the data, reset R979 to 0.
- 3 The NC starts reading the data.
- 4 When the NC finishes reading, it sets R979 to 1.

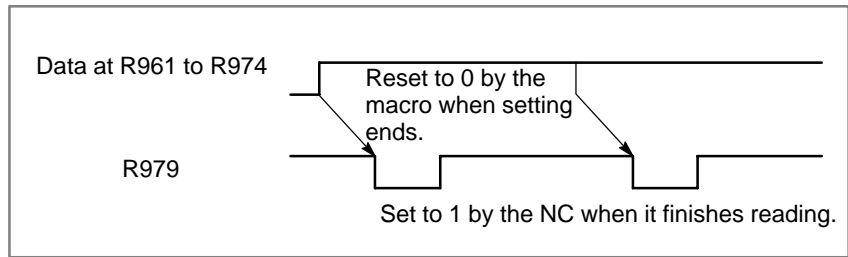

Address	Size	Linear feed	Circular feed
R980 to R963	4 bytes	Distance from the current position to the specified line	Distance from the current position to the specified circle

CAUTION
Be careful not change the data.

MACRO → PMC

Machining guidance mode signals

Machining guidance mode signals GMD4 to GMD0:

Each of these signals indicates the current guidance mode. The relationships between each of these signals and the selected mode are the same as for the machining guidance menu select signal (R952) explained above.

	#7	#6	#5	#4	#3	#2	#1	#0
R954				GMD4	GMD3	GMD2	GMD1	GMD0

Machining guidance start signal GST

Machining guidance stop signal GSP

	#7	#6	#5	#4	#3	#2	#1	#0
R955							GSP	GST

Pressing the [Input End] key (on the standard MDI, “INSERT”) sets the GST to 1. Transfer this signal as the ST for the CNC using the PMC ladder program. The specified machining guidance operation begins.
Pressing the [Input Restart] key (on the standard MDI, “ALTER”) sets the GSP to 1. Transfer this signal as the RST for the CNC using the PMC ladder program. The current machining guidance operation ends.

Timing of signals for machining guidance-based automatic operation

The following descriptions use the timing chart shown below as an example.

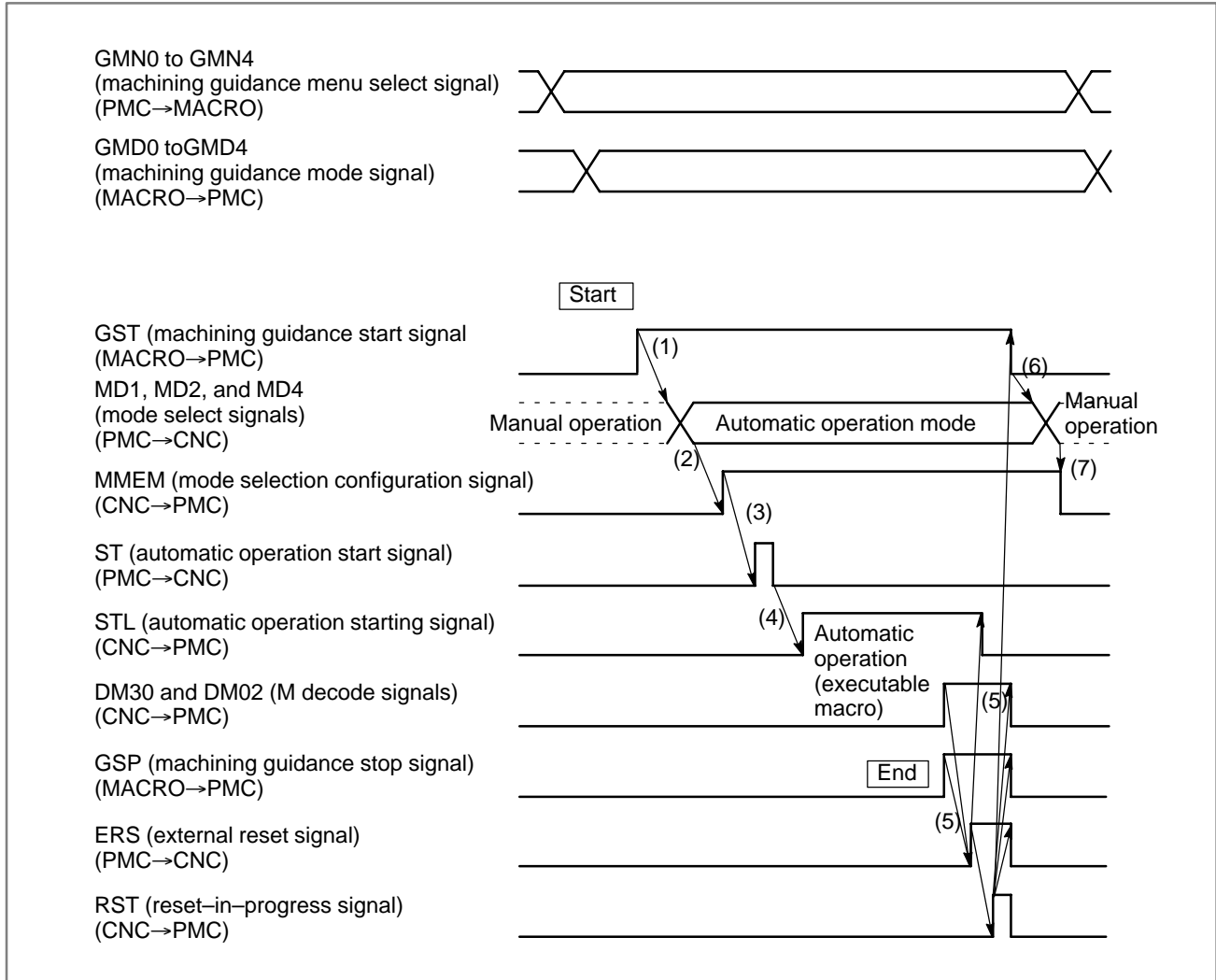

- (1) When the input end key is pressed after machining data is input, MACRO sets the GST signal to 1. When the GST becomes 1, the PMC sets the mode select signal to automatic operation mode.
- (2) On confirming that the automatic operation mode is selected, the CNC sets the MMEM signal to 1.
- (3) When the MMEM signal becomes 1, the PMC turns on the automatic operation start signal to request to start automatic operation.
- (4) When the ST signal becomes 1, the CNC begins automatic operation, starting operation based on the machining guidance execution macro.
- (5) When the execution macro-based operation ends, M02 is output. MACRO outputs the machining guidance stop signal GSP. When the CNC outputs M02, the PMC sets the external reset signal ERS to 1 to reset the CNC. When the CNC is reset, MACRO clears the GST and GSP signals to 0.
- (6) When the GST signal becomes 0, the PMC returns the mode select signal to the state previous to 2 (manual).

- (7) When the GST becomes 0, and the mode select signal returns to the previous state, the CNC resets the mode selection configuration signal MMEM to 0 to terminate machining guidance-based automatic operation.

Timing of signals for machining guidance-based manual operation

The following descriptions use the timing chart shown below as an example.

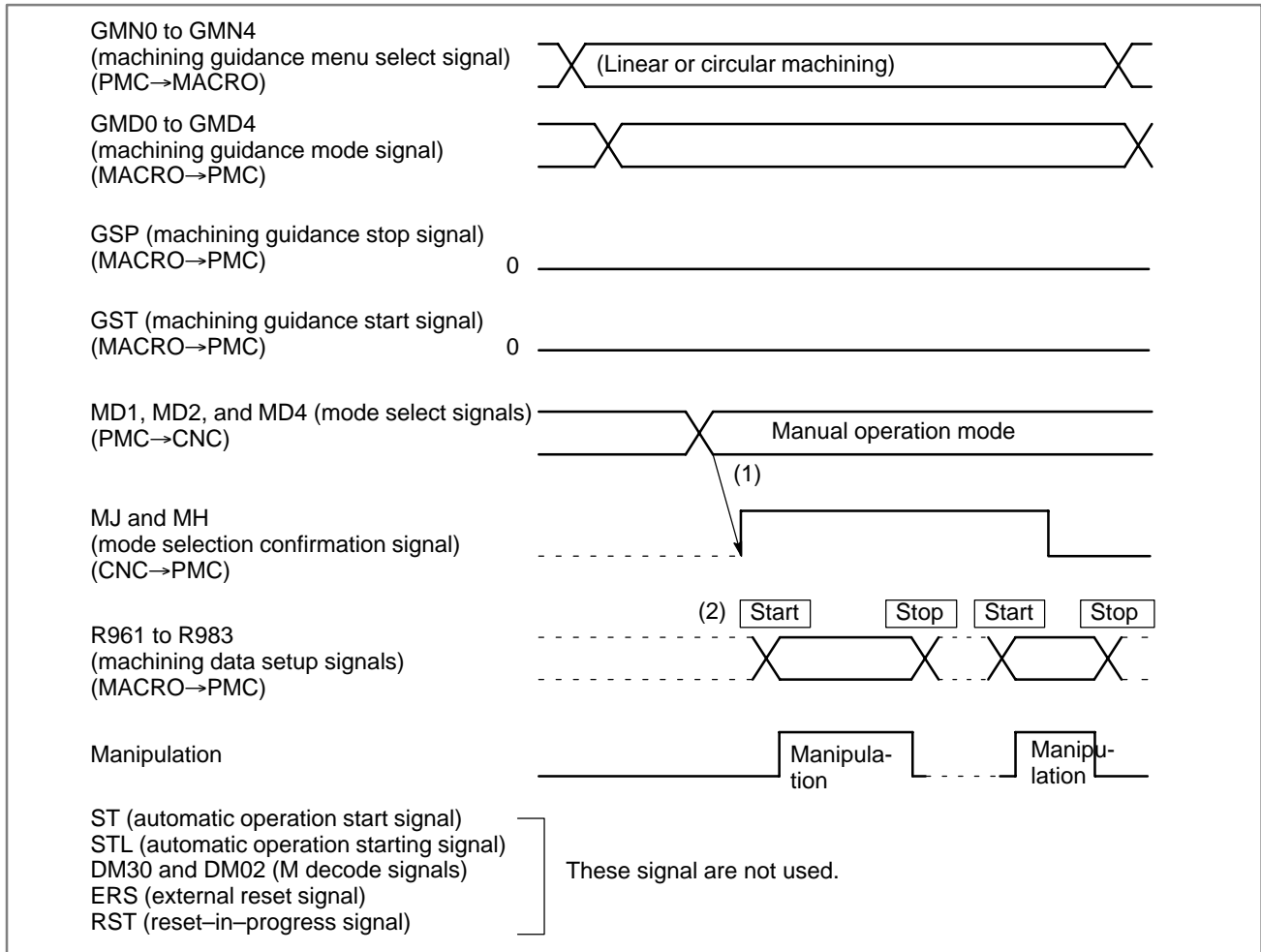

When a line or circle is selected from the machining guidance menu, the PMC sets the machining guidance menu select signal (one of GMN0 to GMN4). According to this signal, MACRO sets a machining guidance mode signal (one of GMD0 to GMD4) to inform the PMC that the selected mode has been entered.

- (1) When a manual mode is selected, the PMC sets the mode select signal to manual mode (JOG or HANDL mode).

(Always select the manual mode for machining guidance-based manual operation.)

When the mode select signal changes to the manual mode, the CNC sets the mode selection confirmation signal MJ or MH.

- (2) When the input end key is pressed after the machining data is entered, MACRO sets data at R961 to R983.

- (3) Rotating the handle causes the specified linear or circular machining to be performed according to the specified machining data.

Constant surface speed function

Constant surface speed function accepted signal

SSCE: When this signal is 1, it indicates that MACRO has accepted a request for constant surface speed control.

Teaching function

Teaching accepted signal

TCE: When this signal is 1, it indicates that MACRO has accepted a request for teaching.

	#7	#6	#5	#4	#3	#2	#1	#0
R957							SSCE	TCE

CNC → MACRO

Circular machining approach direction signal

	#7	#6	#5	#4	#3	#2	#1	#0
R984							SIN	COS

Each of these signals represents the sign of a unit vector in an approach direction when the handle is rotated clockwise during circular machining. (0: Positive 1: Negative)

For example:

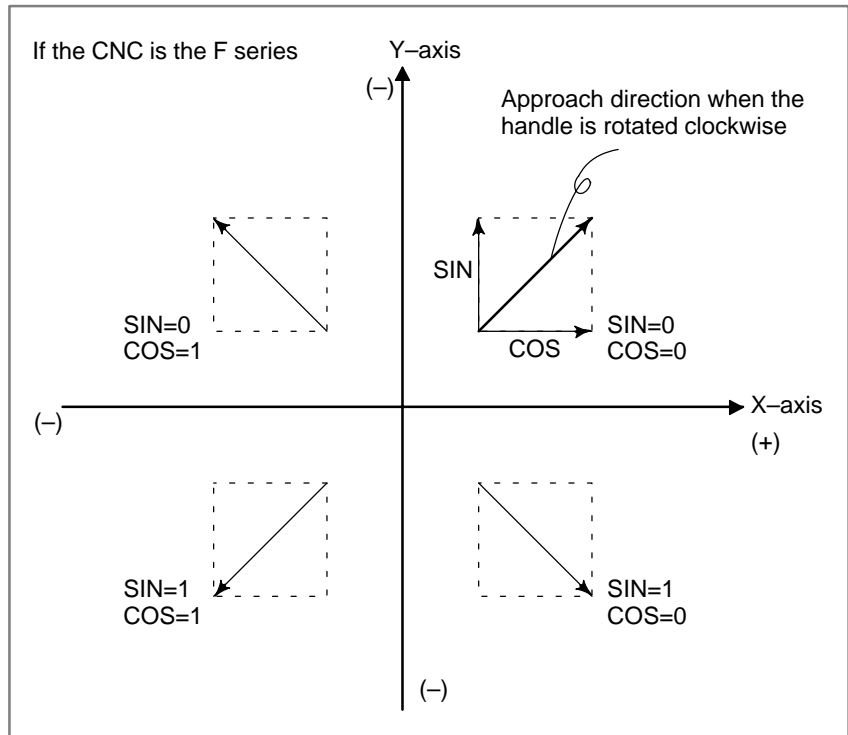

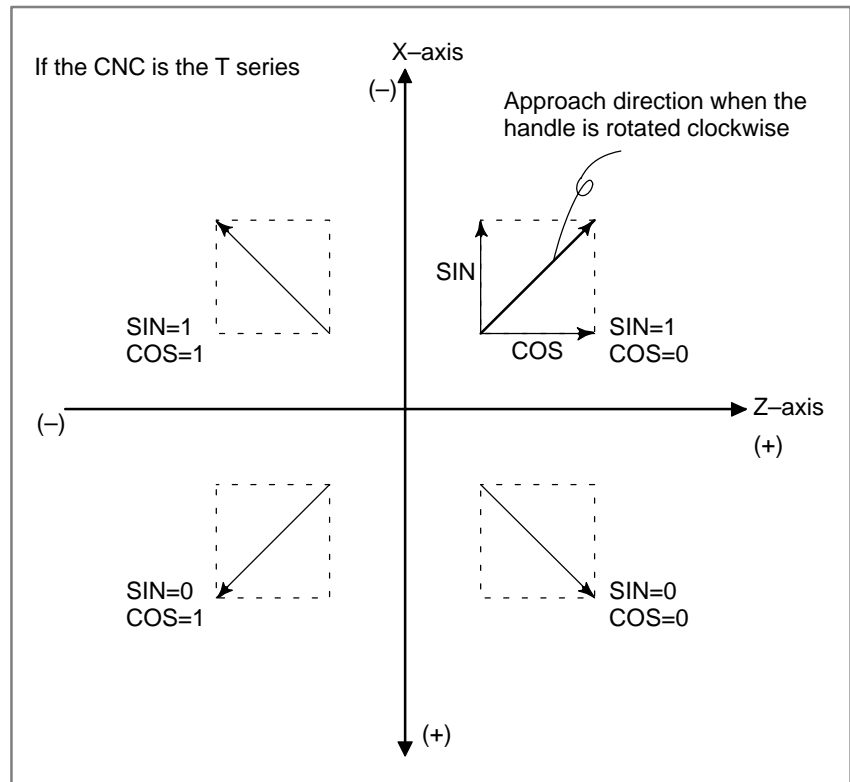

Cutting axis

Circular cutting clockwise/counterclockwise rotation:

CW/CCW: This signal indicates the direction of circular cutting.

1: Counterclockwise

0: Clockwise

Guidance axis shift (cutting)

GUID: When this signal is 1, it indicates that guidance handle-based cutting caused an axis shift.

Guidance axis shift (approach)

APRC: When this signal is 1, it indicates that guidance handle-based approaching caused an axis shift.

First-axis shift

1AXIS: When this signal is 1, it indicates that the first axis has shifted.

Second-axis shift

2AXIS: When this signal is 1, it indicates that the second axis has shifted.

Third-axis shift

3AXIS: When this signal is 1, it indicates that the third axis has shifted.

The first, second, and third axes correspond to the X-, Y-, and Z-axes (20i-F) and the X- and Z-axes (20i-T), respectively.

	#7	#6	#5	#4	#3	#2	#1	#0
R985	CW/CCW	GUID	APRC			3AXIS	2AXIS	1AXIS

19.2 SIGNALS USED FOR POLYGON LIMIT MACHINING (20i-F)

Limit data setup signals

MACRO → PMC

Address	Set data	
R961	4: Specifies a line.	5: Specifies a limit condition.
R962 to R965	Line tilt ($\text{COS}\theta \times 2^{30}$)	Inner datum point coordinate first axis
R966 to R969	Line tilt ($\text{SIN}\theta \times 2^{30}$)	Inner datum point coordinate second axis
R970 to R973	Distance from the origin to the line	—
R974	Line number (0 to 5)	—
R970	—	Number of lines (1 to 6)
R971	—	Outside/inside the limit area 0: Outside forbidden 1: Inside forbidden
R976	—	Plane selection Lower 4 bits: Plane first axis Upper 4 bits: Plane second axis 1: X-axis 2: Y-axis 3: Z-axis
R978	Setup change notification	Setup change notification

MACRO → PMC



Polygon limit mode request signal

MLRQ: MACRO requests the PMC to switch to the polygon limit mode.

PMC → CNC

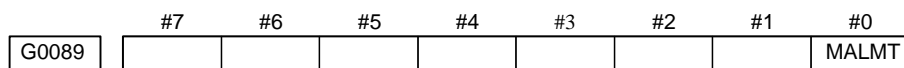

Polygon limit enable/disable signal

MALMT: When this signal 1, it enables the polygon limit.

Timing of signals for polygon limit machining

The following descriptions use the timing chart shown below as an example.

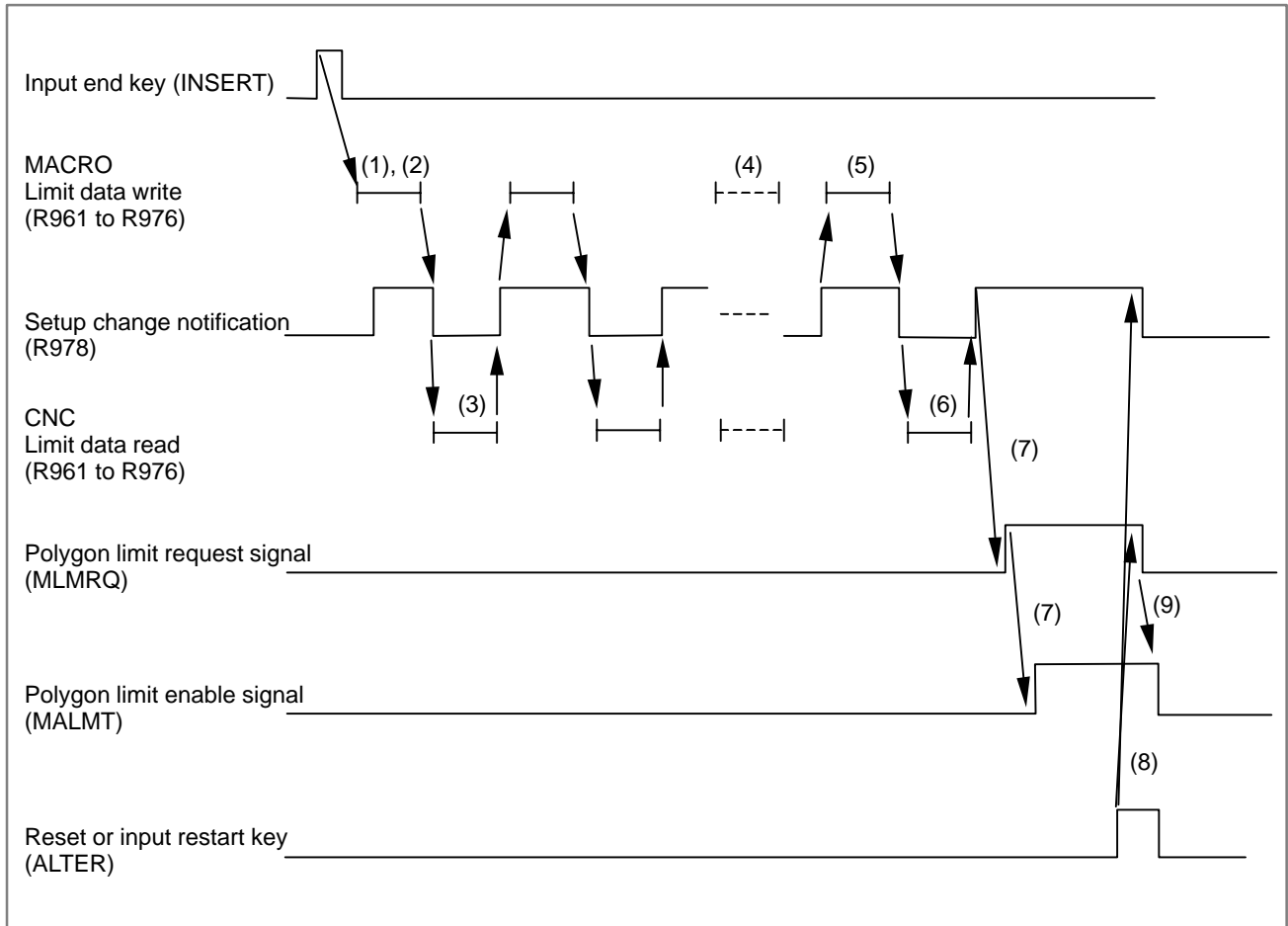

- (1) When the input end key (INSERT) key is pressed after limit figure data is entered on the data input screen, MACRO calculates data for the sides of the polygon and limit conditions.
- (2) After entering the figure data for the first line (line tilt, distance from the origin, and line number) at each address, MACRO resets the setup change notification signal (R978) to 0, and informs the CNC that data for the first line has been entered.
- (3) On detecting that R978 is 0, the CNC reads data from R961 to R976, then sets R978 to 1 to inform MACRO that data reading is completed.
- (4) In response to the above notification, MACRO repeats steps 2 and 3 for all sides (lines) of the polygon.
- (5) After sending data about all sides of the polygon to the CNC, MACRO sets a limit condition definition (5) at R961, and enters limit condition data to R962 to R976. After this, MACRO resets the setup notification signal (R978) to 0.
- (6) When the CNC detects that R978 is 0, it reads data from R961 to R976. When reading ends, the CNC sets R978 to 1 to inform MACRO of it.

- (7) MACRO sets the polygon limit mode request signal (MLMRQ) to 1. On detecting that the signal is 1, the PMC sets the polygon limit enable signal (MALNT) to 1. After this, the CNC enables the polygon limit function according to the limit figure data it received so far.
- (8) To disable the polygon limit function, press the reset key on the MDI/LCD unit or press the input restart key (ALTER). On detecting that either key has been pressed, MACRO resets the setup change notification signal (R978) and the polygon limit mode request signal (MLMRQ) to 0.
- (9) On detecting that the MILRQ signal is 0, the PMC resets the polygon limit enable signal (MALMT) to 0, thus disabling the polygon limit function.

APPENDIX

A

INTERFACE BETWEEN CNC AND PMC



A.1 LIST OF ADDRESSES

A.1.1 Series 16i/18i/160i/180i/ 160is/180is List of Addresses (One-path Control)

Interface addresses among CNC, PMC and Machine Tool are as follows:

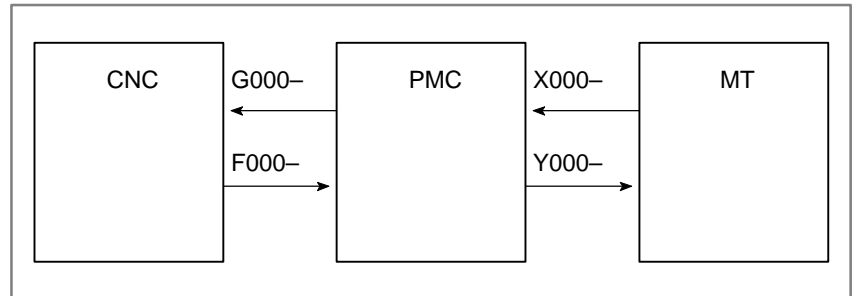

Following shows table of addresses:

In an item where both T series and M series are described, some signals are covered with shade () in the signal address figure as shown below. This means either T series or M series does not have this signal. Upper part is for T series and lower part is for M series.

[Example 1]

Signals EXLM and ST are common signals, STLK is for T series only and RLSOT and RVS are for M series only.

	#7	#6		#2	#1	#0	
G007	RLSOT	EXLM	⋮	ST	STLK	RVS	T series M series

MT → PMC

Address	Bit number								
	7	6	5	4	3	2	1	0	
X000									
X001									
X002									
X003									
X004	SKIP	ESKIP SKIP6	-MIT2 SKIP5	+MIT2 SKIP4	-MIT1 SKIP3	+MIT1 SKIP2	ZAE SKIP8	XAE SKIP7	(T series)
	SKIP	ESKIP SKIP6	SKIP5	SKIP4	SKIP3	ZAE SKIP2	YAE SKIP8	XAE SKIP7	(M series)
X005									
X006									
X007									
X008				*ESP					
X009	*DEC8	*DEC7	*DEC6	*DEC5	*DEC4	*DEC3	*DEC2	*DEC1	
X010									
X011									
X012									

PMC → CNC

Address	Bit number							
	#7	6	5	4	3	2	1	0
G000	ED7	ED6	ED5	ED4	ED3	ED2	ED1	ED0
G001	ED15	ED14	ED13	ED12	ED11	ED10	ED9	ED8
G002	ESTB	EA6	EA5	EA4	EA3	EA2	EA1	EA0
G003								
G004			MFIN3	MFIN2	FIN			
G005	BFIN	AFL		BFIN	TFIN	SFIN	EFIN	MFIN
G006		SKIPP		OVC		*ABSM		SRN
G007	RLSOT	EXLM	*FLWU	RLSOT3		ST	STLK	RVS
G008	ERS	RRW	*SP	*ESP	*BSL		*CSL	*IT
G009				PN16	PN8	PN4	PN2	PN1
G010	*JV7	*JV6	*JV5	*JV4	*JV3	*JV2	*JV1	*JV0
G011	*JV15	*JV14	*JV13	*JV12	*JV11	*JV10	*JV9	*JV8
G012	*FV7	*FV6	*FV5	*FV4	*FV3	*FV2	*FV1	*FV0
G013	*AFV7	*AFV6	*AFV5	*AFV4	*AFV3	*AFV2	*AFV1	*AFV0
G014							ROV2	ROV1
G015								
G016	F1D							MSDFON
G017								
G018	HS2D	HS2C	HS2B	HS2A	HS1D	HS1C	HS1B	HS1A
G019	RT		MP2	MP1	HS3D	HS3C	HS3B	HS3A
G020								
G021								
G022								
G023	ALNGH	RGHTH						
G024	EPN7	EPN6	EPN5	EPN4	EPN3	EPN2	EPN1	EPN0

	7	6	5	4	3	2	1	0
G025	EPNS		EPN13	EPN12	EPN11	EPN10	EPN9	EPN8
G026		*SSTP4			SWS4		PC4SLC	PC3SLC
G027	CON		*SSTP3	*SSTP2	*SSTP1	SWS3	SWS2	SWS1
G028	PC2SLC	SPSTP	*SCPF	*SUCPF		GR2	GR1	
G029		*SSTP	SOR	SAR		GR31		GR21
G030	SOV7	SOV6	SOV5	SOV4	SOV3	SOV2	SOV1	SOV0
G031	PKESS2	PKESS1		GR4I				
G032	R08I	R07I	R06I	R05I	R04I	R03I	R02I	R01I
G033	SIND	SSIN	SGN		R12I	R11I	R10I	R09I
G034	R08I2	R07I2	R06I2	R05I2	R04I2	R03I2	R02I2	R01I2
G035	SIND2	SSIN2	SGN2		R12I2	R11I2	R10I2	R09I2
G036	R08I3	R07I3	R06I3	R05I3	R04I3	R03I3	R02I3	R01I3
G037	SIND3	SSIN3	SGN3		R12I3	R11I3	R10I3	R09I3
G038	*BECLP	*BEUCP			SPPHS	SPSYC		*PLSST
G039	GOQSM	WOQSM	OFN5	OFN4	OFN3	OFN2	OFN1	OFN0
G040	WOSET	PRC	S2TLS					OFN6
G041	HS2ID	HS2IC	HS2IB	HS2IA	HS1ID	HS1IC	HS1IB	HS1IA
G042	DMMC				HS3ID	HS3IC	HS3IB	HS3IA
G043	ZRN		DNCI			MD4	MD2	MD1
G044							MLK	BDT1
G045	BDT9	BDT8	BDT7	BDT6	BDT5	BDT4	BDT3	BDT2
G046	DRN	KEY4	KEY3	KEY2	KEY1		SBK	KEYPRM
G047	TL128	TL64	TL32	TL16	TL08	TL04	TL02	TL01
G048	TLRST	TLRSTI	TLSKP					TL256
G049	*TLV7	*TLV6	*TLV5	*TLV4	*TLV3	*TLV2	*TLV1	*TLV0

	7	6	5	4	3	2	1	0
G050							*TLV9	*TLV8
G051	*CHLD	CHPST			*CHP8	*CHP4	*CHP2	*CHP0
G052	RMTDI7	RMTDI6	RMTDI5	RMTDI4	RMTDI3	RMTDI2	RMTDI1	RMTDI0
G053	CDZ	SMZ			UINT			TMRON
G054	UI007	UI006	UI005	UI004	UI003	UI002	UI001	UI000
G055	UI015	UI014	UI013	UI012	UI011	UI010	UI009	UI008
G056	UI023	UI022	UI021	UI020	UI019	UI018	UI017	UI016
G057	UI031	UI030	UI029	UI028	UI027	UI026	UI025	UI024
G058		STWD	STRD		EXWT	EXSTP	EXRD	MINP
G059							TRRTN	TRESC
G060	*TSB							
G061			RGTSP2	RGTSP1				RGTAP
G062		RTNT	PDT2	PDT1			*CRTOF	
G063			NOZAGC					
G064		ESRSYC						
G065	HCSKP4	HCSKP3	HCSKP2	HCSKP1				
G066	EKSET		MSPC	RTRCT		HOBCAN	ENBKY	IGNVRY
G067					MCHK	MMOD	MRVM	
G068								
G069								
G070	MRDYA	ORCMA	SFRA	SRVA	CTH1A	CTH2A	TLMHA	TLMLA
G071	RCHA	RSLA	INTGA	SOCNA	MCFNA	SPSLA	*ESPA	ARSTA
G072	RCHHGA	MFNHGA	INCMDA	OVRA	DEFMDA	NRROA	ROTAA	INDXA
G073				DSCNA	SORSLA	MPOFA	SLVA	MORCMA
G074	MRDYB	ORCMB	SFRB	SRVB	CTH1B	CTH2B	TLMHB	TLMLB

	7	6	5	4	3	2	1	0
G075	RCHB	RSLB	INTGB	SOCNB	MCFNB	SPSLB	*ESPB	ARSTB
G076	RCHHGB	MFNHGB	INCMDB	OVRB	DEFMDB	NRROB	ROTAB	INDXB
G077				DSCNB	SORSLB	MPOFB	SLVB	MORCMB
G078	SHA07	SHA06	SHA05	SHA04	SHA03	SHA02	SHA01	SHA00
G079					SHA11	SHA10	SHA09	SHA08
G080	SHB07	SHB06	SHB05	SHB04	SHB03	SHB02	SHB01	SHB00
G081					SHB11	SHB10	SHB09	SHB08
G082	Reserve for order made macro							
G083	Reserve for order made macro							
G084								
G085								
G086					-Ja	+Ja	-Jg	+Jg
G087								
G088								
G089								
G090	G2SLC	G2Y	G2Z	G2X		G2RVY	G2RVZ	G2RVX
G091					SRLNI3	SRLNI2	SRLNI1	SRLNI0
G092				BGEN	BGIALM	BGION	IOLS	IOLACK
G093								
G094								
G095								
G096	HROV	*HROV6	*HROV5	*HROV4	*HROV3	*HROV2	*HROV1	*HROV0
G097								
G098	EKC7	EKC6	EKC5	EKC4	EKC3	EKC2	EKC1	EKC0
G099								

	7	6	5	4	3	2	1	0
G100	+J8	+J7	+J6	+J5	+J4	+J3	+J2	+J1
G101								
G102	-J8	-J7	-J6	-J5	-J4	-J3	-J2	-J1
G103								
G104	+EXL8	+EXL7	+EXL6	+EXL5	+EXL4	+EXL3	+EXL2	+EXL1
G105	-EXL8	-EXL7	-EXL6	-EXL5	-EXL4	-EXL3	-EXL2	-EXL1
G106	MI8	MI7	MI6	MI5	MI4	MI3	MI2	MI1
G107								
G108	MLK8	MLK7	MLK6	MLK5	MLK4	MLK3	MLK2	MLK1
G109								
G110	+LM8	+LM7	+LM6	+LM5	+LM4	+LM3	+LM2	+LM1
G111								
G112	-LM8	-LM7	-LM6	-LM5	-LM4	-LM3	-LM2	-LM1
G113								
G114	*+L8	*+L7	*+L6	*+L5	*+L4	*+L3	*+L2	*+L1
G115								
G116	*-L8	*-L7	*-L6	*-L5	*-L4	*-L3	*-L2	*-L1
G117								
G118	*+ED8	*+ED7	*+ED6	*+ED5	*+ED4	*+ED3	*+ED2	*+ED1
G119								
G120	*-ED8	*-ED7	*-ED6	*-ED5	*-ED4	*-ED3	*-ED2	*-ED1
G121								
G122	<small>PK8 PKESS2</small>	<small>PK7 PKESS1</small>	PK6	PK5	PK4	PK3	PK2	PK1
	PKESS2	PKESS1						
G123								

(T series)
(M series)

	7	6	5	4	3	2	1	0
G124	DTCH8	DTCH7	DTCH6	DTCH5	DTCH4	DTCH3	DTCH2	DTCH1
G125	IUDD8	IUDD7	IUDD6	IUDD5	IUDD4	IUDD3	IUDD2	IUDD1
G126	SVF8	SVF7	SVF6	SVF5	SVF4	SVF3	SVF2	SVF1
G127								
G128								
G129								
G130	*IT8	*IT7	*IT6	*IT5	*IT4	*IT3	*IT2	*IT1
G131								
G132					+MIT4	+MIT3	+MIT2	+MIT1
G133								
G134					-MIT4	-MIT3	-MIT2	-MIT1
G135								
G136	EAX8	EAX7	EAX6	EAX5	EAX4	EAX3	EAX2	EAX1
G137								
G138	SYNC8	SYNC7	SYNC6	SYNC5	SYNC4	SYNC3	SYNC2	SYNC1
G139								
G140	SYNCJ8	SYNCJ7	SYNCJ6	SYNCJ5	SYNCJ4	SYNCJ3	SYNCJ2	SYNCJ1
G141								
G142	EBUFA	ECLRA	ESTPA	ESOFA	ESBKA	EMBUFA	ELCKZA	EFINA
G143	EMSBKA	EC6A	EC5A	EC4A	EC3A	EC2A	EC1A	EC0A
G144	EIF7A	EIF6A	EIF5A	EIF4A	EIF3A	EIF2A	EIF1A	EIF0A
G145	EIF15A	EIF14A	EIF13A	EIF12A	EIF11A	EIF10A	EIF9A	EIF8A
G146	EID7A	EID6A	EID5A	EID4A	EID3A	EID2A	EID1A	EID0A
G147	EID15A	EID14A	EID13A	EID12A	EID11A	EID10A	EID9A	EID8A
G148	EID23A	EID22A	EID21A	EID20A	EID19A	EID18A	EID17A	EID16A

	7	6	5	4	3	2	1	0
G149	EID31A	EID30A	EID29A	EID28A	EID27A	EID26A	EID25A	EID24A
G150	DRNE	RTE	OVCE				ROV2E	ROV1E
G151	*FV7E	*FV6E	*FV5E	*FV4E	*FV3E	*FV2E	*FV1E	*FV0E
G152								
G153								
G154	EBUGB	ECLRB	ESTPB	ESOFB	ESBKB	EMBUGB	ELCKZB	EFINB
G155	EMSBKB	EC6B	EC5B	EC4B	EC3B	EC2B	EC1B	EC0B
G156	EIF7B	EIF6B	EIF5B	EIF4B	EIF3B	EIF2B	EIF1B	EIF0B
G157	EIF15B	EIF14B	EIF13B	EIF12B	EIF11B	EIF10B	EIF9B	EIF8B
G158	EID7B	EID6B	EID5B	EID4B	EID3B	EID2B	EID1B	EID0B
G159	EID15B	EID14B	EID13B	EID12B	EID11B	EID10B	EID9B	EID8B
G160	EID23B	EID22B	EID21B	EID20B	EID19B	EID18B	EID17B	EID16B
G161	EID31B	EID30B	EID29B	EID28B	EID27B	EID26B	EID25B	EID24B
G162								
G163								
G164								
G165								
G166	EBUGC	ECLRC	ESTPC	ESOFC	ESBKC	EMBUGC	ELCKZC	EFINC
G167	EMSBKC	EC6C	EC5C	EC4C	EC3C	EC2C	EC1C	EC0C
G168	EIF7C	EIF6C	EIF5C	EIF4C	EIF3C	EIF2C	EIF1C	EIF0C
G169	EIF15C	EIF14C	EIF13C	EIF12C	EIF11C	EIF10C	EIF9C	EIF8C
G170	EID7C	EID6C	EID5C	EID4C	EID3C	EID2C	EID1C	EID0C
G171	EID15C	EID14C	EID13C	EID12C	EID11C	EID10C	EID9C	EID8C
G172	EID23C	EID22C	EID21C	EID20C	EID19C	EID18C	EID17C	EID16C
G173	EID31C	EID30C	EID29C	EID28C	EID27C	EID26C	EID25C	EID24C

	7	6	5	4	3	2	1	0
G174								
G175								
G176								
G177								
G178	EBUGD	ECLRD	ESTPD	ESOFD	ESBKD	EMBUGD	ELCKZD	EFIND
G179	EMSBKD	EC6D	EC5D	EC4D	EC3D	EC2D	EC1D	EC0D
G180	EIF7D	EIF6D	EIF5D	EIF4D	EIF3D	EIF2D	EIF1D	EIF0D
G181	EIF15D	EIF14D	EIF13D	EIF12D	EIF11D	EIF10D	EIF9D	EIF8D
G182	EID7D	EID6D	EID5D	EID4D	EID3D	EID2D	EID1D	EID0D
G183	EID15D	EID14D	EID13D	EID12D	EID11D	EID10D	EID9D	EID8D
G184	EID23D	EID22D	EID21D	EID20D	EID19D	EID18D	EID17D	EID16D
G185	EID31D	EID30D	EID29D	EID28D	EID27D	EID26D	EID25D	EID24D
G186								
G187								
G188								
G189								
G190								
G191								
G192	IGVRY8	IGVRY7	IGVRY6	IGVRY5	IGVRY4	IGVRY3	IGVRY2	IGVRY1
G193								
G194								
G195								
G196								
G197					MTD	MTC	MTB	MTA
G198	NPOS8	NPOS7	NPOS6	NPOS5	NPOS4	NPOS3	NPOS2	NPOS1

	7	6	5	4	3	2	1	0
G199							IOLBH3	IOLBH2
G200	EASIP8	EASIP7	EASIP6	EASIP5	EASIP4	EASIP3	EASIP2	EASIP1
G201			JGRD3	JGRD2	JGRD1			
G202								
G203						FTCLR	FTCAL	FTCMD
G204	MRDYC	ORCML	SFRC	SRVC	CTH1C	CTH2C	TLMHC	TMLC
G205	RCHC	RSLC	INTGC	SOCNC	MCFNC	SPSLC	*ESPC	ARSTC
G206	RCHHGC	MFNHGC	INCMDC	OVRC	DEFMDC	NRROC	ROTAC	INDXC
G207				DSCNC	SORSCLC	MPOFC	SLVC	MORCMC
G208	SHC07	SHC06	SHC05	SHC04	SHC03	SHC02	SHC01	SHC00
G209					SHC11	SHC10	SHC09	SHC08
G210								
G211								
G212								
G213								
G214								
G215								
G216								
G217								
G218								
G219								
G220								
G221								
G222								
G223								

	7	6	5	4	3	2	1	0
G224								
G225								
G226								
G227								
G228								
G229								
G230								
G231								
G232								
G233								
G234								
G235								
G236								
G237								
G238								
G239								
G240								
G241								
G242								
G243								
G244								
G245								
G246								
G247								
G248								

	7	6	5	4	3	2	1	0
G249								
G250								
G251								
G252								
G253								
G254								
G255								
G256								
G257								
G258								
G259								
G260								
G261								
G262								
G263								
G264								
G265								
G266	MRDYD	ORCMD	SFRD	SRVD	CTH1D	CTH2D	TLMHD	TLMLD
G267	RCHD	RSLD	INTGD	SOCND	MCFND	SPSLD	*ESPD	ARSTD
G268	RCHHGD	MFNHGD	INCMDD	OVRD	DEFMDD	NRROD	ROTAD	INDXD
G269				DSCND	SORSLD	MPOFD	SLVD	MORCMD
G270	SHD07	SHD06	SHD05	SHD04	SHD03	SHD02	SHD01	SHD00
G271					SHD11	SHD10	SHD09	SHD08
G272	R08I4	R07I4	R06I4	R05I4	R04I4	R03I4	R02I4	R01I4
G273	SIND4	SSIN4	SGN4		R12I4	R11I4	R10I4	R09I4

	7	6	5	4	3	2	1	0
G274								
G275								
G276	UI107	UI106	UI105	UI104	UI103	UI102	UI101	UI100
G277	UI115	UI114	UI113	UI112	UI111	UI110	UI109	UI108
G278	UI123	UI122	UI121	UI120	UI119	UI118	UI117	UI116
G279	UI131	UI130	UI129	UI128	UI127	UI126	UI125	UI124
G280	UI207	UI206	UI205	UI204	UI203	UI202	UI201	UI200
G281	UI215	UI214	UI213	UI212	UI211	UI210	UI209	UI208
G282	UI223	UI222	UI221	UI220	UI219	UI218	UI217	UI216
G283	UI231	UI230	UI229	UI228	UI227	UI226	UI225	UI224
G284	UI307	UI306	UI305	UI304	UI303	UI302	UI301	UI300
G285	UI315	UI314	UI313	UI312	UI311	UI310	UI309	UI308
G286	UI323	UI322	UI321	UI320	UI319	UI318	UI317	UI316
G287	UI331	UI330	UI329	UI328	UI327	UI326	UI325	UI324
G288								
G289								
G290								
G291								
G292	ITCD							
G293								
G294								
G295								
G296								
G297								
G298								

	7	6	5	4	3	2	1	0
G299								
G300								
G301								
G302								
G303								
G304								
G305								
G306								
G307								
G308								
G309								
G310								
G311								
G312								
G313								
G314								
G315								
G316								
G317								
G318								
G319								

CNC → PMC

Address	Bit number							
	7	6	5	4	3	2	1	0
F000	OP	SA	STL	SPL				RWD
F001	MA		TAP	ENB	DEN	BAL	RST	AL
F002	MDRN	CUT		SRNMV	THRD	CSS	RPDO	INCH
F003	MTCHIN	MEDT	MMEM	MRMT	MMDI	MJ	MH	MINC
F004			MREF	MAFL	MSBK	MABSM	MMLK	MBDT1
F005	MBDT9	MBDT8	MBDT7	MBDT6	MBDT5	MBDT4	MBDT3	MBDT2
F006								
F007	BF			BF	TF	SF	EFD	MF
F008			MF3	MF2				EF
F009	DM00	DM01	DM02	DM30				
F010	M07	M06	M05	M04	M03	M02	M01	M00
F011	M15	M14	M13	M12	M11	M10	M09	M08
F012	M23	M22	M21	M20	M19	M18	M17	M16
F013	M31	M30	M29	M28	M27	M26	M25	M24
F014	M207	M206	M205	M204	M203	M202	M201	M200
F015	M215	M214	M213	M212	M211	M210	M209	M208
F016	M307	M306	M305	M304	M303	M302	M301	M300
F017	M315	M314	M313	M312	M311	M310	M309	M308
F018								
F019								
F020								
F021								
F022	S07	S06	S05	S04	S03	S02	S01	S00
F023	S15	S14	S13	S12	S11	S10	S09	S08
F024	S23	S22	S21	S20	S19	S18	S17	S16

	7	6	5	4	3	2	1	0
F025	S31	S30	S29	S28	S27	S26	S25	S24
F026	T07	T06	T05	T04	T03	T02	T01	T00
F027	T15	T14	T13	T12	T11	T10	T09	T08
F028	T23	T22	T21	T20	T19	T18	T17	T16
F029	T31	T30	T29	T28	T27	T26	T25	T24
F030	B07	B06	B05	B04	B03	B02	B01	B00
F031	B15	B14	B13	B12	B11	B10	B09	B08
F032	B23	B22	B21	B20	B19	B18	B17	B16
F033	B31	B30	B29	B28	B27	B26	B25	B24
F034	SRSRDY	SRSP1R	SRSP2R	SRSP3R	SRSP4R	GR3O	GR2O	GR1O
F035								SPAL
F036	R08O	R07O	R06O	R05O	R04O	R03O	R02O	R01O
F037					R12O	R11O	R10O	R09O
F038					ENB3	ENB2	SUCLP	SCLP
F039					CHPCYL	CHPMD	ENB4	
F040	AR7	AR6	AR5	AR4	AR3	AR2	AR1	AR0
F041	AR15	AR14	AR13	AR12	AR11	AR10	AR09	AR08
F042								
F043								
F044				SYCAL	FSPPH	FSPSY	FSCSL	
F045	ORARA	TLMA	LDT2A	LDT1A	SARA	SDTA	SSTA	ALMA
F046	MORA2A	MORA1A	PORA2A	SLVSA	RCFNA	RCHPA	CFINA	CHPA
F047				EXOFA	SORENA	MSOVRA	INCSTA	PC1DTA
F048								
F049	ORARB	TLMB	LDT2B	LDT1B	SARB	SDTB	SSTB	ALMB

	7	6	5	4	3	2	1	0
F050	MORA2B	MORA1B	PORA2B	SLVSB	RCFNB	RCHPB	CFINB	CHPB
F051				EXOFB	SORENB	MSOVRB	INCSTB	PC1DTB
F052								
F053	EKENB			BGEACT	RPALM	RPBSY	PRGDPL	INHKY
F054	UO007	UO006	UO005	UO004	UO003	UO002	UO001	UO000
F055	UO015	UO014	UO013	UO012	UO011	UO010	UO009	UO008
F056	UO107	UO106	UO105	UO104	UO103	UO102	UO101	UO100
F057	UO115	UO114	UO113	UO112	UO111	UO110	UO109	UO108
F058	UO123	UO122	UO121	UO120	UO119	UO118	UO117	UO116
F059	UO131	UO130	UO129	UO128	UO127	UO126	UO125	UO124
F060						ESCAN	ESEND	EREND
F061							BCLP	BUCLP
F062	PRTSF			S2MES	S1MES			
F063	PSYN					PSAR	PSE2	PSE1
F064					TLCHB	TLCHI	TLNW	TLCH
F065	HOBSYN	SYNMOD	MSPCF	RTRCTF			RGSPM	RGSP
F066	EXHPCC	MHPCC	PECK2				RTPT	G08MD
F067								
F068								
F069	RMTDO7	RMTDO6	RMTDO5	RMTDO4	RMTDO3	RMTDO2	RMTDO1	RMTDO0
F070	PSW08	PSW07	PSW06	PSW05	PSW04	PSW03	PSW02	PSW01
F071	PSW16	PSW15	PSW14	PSW13	PSW12	PSW11	PSW10	PSW09
F072	OUT7	OUT6	OUT5	OUT4	OUT3	OUT2	OUT1	OUT0
F073				ZRNO		MD4O	MD2O	MD1O
F074								

	7	6	5	4	3	2	1	0
F075	SPO	KEYO	DRNO	MLKO	SBKO	BDTO		
F076			ROV2O	ROV1O	RTAP		MP2O	MP1O
F077		RTO			HS1DO	HS1CO	HS1BO	HS1AO
F078	*FV7O	*FV6O	*FV5O	*FV4O	*FV3O	*FV2O	*FV1O	*FV0O
F079	*JV7O	*JV6O	*JV5O	*JV4O	*JV3O	*JV2O	*JV1O	*JV0O
F080	*JV15O	*JV14O	*JV13O	*JV12O	*JV11O	*JV10O	*JV9O	*JV8O
F081	- J4O	+ J4O	- J3O	+ J3O	- J2O	+ J2O	- J1O	+ J1O
F082						RVSL		
F083								
F084								
F085								
F086								
F087								
F088								
F089								
F090					ABTSP3	ABTSP2	ABTSP1	ABTQSV
F091								
F092			TRSPS		TRACT			
F093	SVWRN4	SVWRN3	SVWRN2	SVWRN1				LIFOVR
F094	ZP8	ZP7	ZP6	ZP5	ZP4	ZP3	ZP2	ZP1
F095								
F096	ZP28	ZP27	ZP26	ZP25	ZP24	ZP23	ZP22	ZP21
F097								
F098	ZP38	ZP37	ZP36	ZP35	ZP34	ZP33	ZP32	ZP31
F099								

	7	6	5	4	3	2	1	0
F100	ZP48	ZP47	ZP46	ZP45	ZP44	ZP43	ZP42	ZP41
F101								
F102	MV8	MV7	MV6	MV5	MV4	MV3	MV2	MV1
F103								
F104	INP8	INP7	INP6	INP5	INP4	INP3	INP2	INP1
F105								
F106	MVD8	MVD7	MVD6	MVD5	MVD4	MVD3	MVD2	MVD1
F107								
F108	MMI8	MMI7	MMI6	MMI5	MMI4	MMI3	MMI2	MMI1
F109								
F110	MDTCH8	MDTCH7	MDTCH6	MDTCH5	MDTCH4	MDTCH3	MDTCH2	MDTCH1
F111								
F112	EADEN8	EADEN7	EADEN6	EADEN5	EADEN4	EADEN3	EADEN2	EADEN1
F113								
F114	TRQL8	TRQL7	TRQL6	TRQL5	TRQL4	TRQL3	TRQL2	TRQL1
F115								
F116	FRP8	FRP7	FRP6	FRP5	FRP4	FRP3	FRP2	FRP1
F117								
F118	SYN80	SYN70	SYN60	SYN50	SYN40	SYN30	SYN20	SYN10
F119								
F120	ZRF8	ZRF7	ZRF6	ZRF5	ZRF4	ZRF3	ZRF2	ZRF1
F121								
F122	HDO7	HDO6	HDO5	HDO4	HDO3	HDO2	HDO1	HDO0
F123								
F124	+OT8	+OT7	+OT6	+OT5	+OT4	+OT3	+OT2	+OT1

	7	6	5	4	3	2	1	0
F125								
F126	-OT8	-OT7	-OT6	-OT5	-OT4	-OT3	-OT2	-OT1
F127								
F128								
F129	*EAXSL		EOV0					
F130	EBSYA	EOTNA	EOTPA	EGENA	EDENA	EIALA	ECKZA	EINPA
F131							EABUFA	EMFA
F132	EM28A	EM24A	EM22A	EM21A	EM18A	EM14A	EM12A	EM11A
F133	EBSYB	EOTNB	EOTPB	EGENB	EDENB	EIALB	ECKZB	EINPB
F134							EABUFB	EMFB
F135	EM28B	EM24B	EM22B	EM21B	EM18B	EM14B	EM12B	EM11B
F136	EBSYC	EOTNC	EOTPC	EGENC	EDENC	EIALC	ECKZC	EINPC
F137							EABUFC	EMFC
F138	EM28C	EM24C	EM22C	EM21C	EM18C	EM14C	EM12C	EM11C
F139	EBSYD	EOTND	EOTPD	EGEND	EDEND	EIALD	ECKZD	EINPD
F140							EABUFD	EMFD
F141	EM28D	EM24D	EM22D	EM21D	EM18D	EM14D	EM12D	EM11D
F142	EM48A	EM44A	EM42A	EM41A	EM38A	EM34A	EM32A	EM31A
F143								
F144								
F145	EM48B	EM44B	EM42B	EM41B	EM38B	EM34B	EM32B	EM31B
F146								
F147								
F148	EM48C	EM44C	EM42C	EM41C	EM38C	EM34C	EM32C	EM31C
F149								

	7	6	5	4	3	2	1	0
F150								
F151	EM48D	EM44D	EM42D	EM41D	EM38D	EM34D	EM32D	EM31D
F152								
F153								
F154								
F155								
F156								
F157								
F158								
F159								
F160								
F161								
F162								
F163								
F164								
F165								
F166								
F167								
F168	ORARC	TLMC	LDT2C	LDT1C	SARC	SDTC	SSTC	ALMC
F169	MORA2C	MORA1C	PORA2C	SLVSC	RCFNC	RCHPC	CFINC	CHPC
F170				EXOFC	SORENC	MSOVR	INCSTC	PC1DTC
F171								
F172	PBATL	PBATZ						
F173								
F174								

	7	6	5	4	3	2	1	0
F175								
F176								
F177	EDGN	EPARM	EVAR	EPRG	EWGIO	ESTPIO	ERDIO	IOLNK
F178					SRLNO3	SRLNO2	SRLNO1	SRLNO0
F179								
F180	CLRCH8	CLRCH7	CLRCH6	CLRCH5	CLRCH4	CLRCH3	CLRCH2	CLRCH1
F181								
F182	EACNT8	EACNT7	EACNT6	EACNT5	EACNT4	EACNT3	EACNT2	EACNT1
F183								
F184								
F185								
F186								
F187								
F188								
F189								
F190								
F191								
F192								
F193								
F194								
F195								
F196								
F197					MFSYND	MFSYNC	MFSYNB	MFSYNA
F198								
F199								

	7	6	5	4	3	2	1	0
F200								
F201								
F202								
F203								
F204								
F205								
F206								
F207								
F208	EGBM8	EGBM7	EGBM6	EGBM5	EGBM4	EGBM3	EGBM2	EGBM1
F209								
F210								
F211								
F212								
F213								
F214								
F215								
F216								
F217								
F218								
F219								
F220								
F221								
F222								
F223								
F224								

	7	6	5	4	3	2	1	0
F225								
F226								
F227								
F228								
F229								
F230								
F231								
F232								
F233								
F234								
F235								
F236								
F237								
F238								
F239								
F240								
F241								
F242								
F243								
F244								
F245								
F246								
F247								
F248								
F249								

	7	6	5	4	3	2	1	0
F250								
F251								
F252								
F253								
F254								
F255								
F256								
F257								
F258								
F259								
F260								
F261								
F262								
F263								
F264	SPWRN8	SPWRN7	SPWRN6	SPWRN5	SPWRN4	SPWRN3	SPWRN2	SPWRN1
F265								SPWRN9
F266	ORARD	TLMD	LDT2D	LDT1D	SARD	SDTD	SSTD	ALMD
F267	MORA2D	MORA1D	PORA2D	SLVSD	RCFND	RCHPD	CFIND	CHPD
F268				EXOFD	SOREND	MSOVRD	INCSTD	PC1DTD
F269								
F270								
F271								
F272								
F273								
F274								

	7	6	5	4	3	2	1	0
F275								
F276	UO023	UO022	UO021	UO020	UO019	UO018	UO017	UO016
F277	UO031	UO030	UO029	UO028	UO027	UO026	UO025	UO024
F278								
F279								
F280	UO207	UO206	UO205	UO204	UO203	UO202	UO201	UO200
F281	UO215	UO214	UO213	UO212	UO211	UO210	UO209	UO208
F282	UO223	UO222	UO221	UO220	UO219	UO218	UO217	UO216
F283	UO231	UO230	UO229	UO228	UO227	UO226	UO225	UO224
F284	UO307	UO306	UO305	UO304	UO303	UO302	UO301	UO300
F285	UO315	UO314	UO313	UO312	UO311	UO310	UO309	UO308
F286	UO323	UO322	UO321	UO320	UO319	UO318	UO317	UO316
F287	UO331	UO330	UO329	UO328	UO327	UO326	UO325	UO324
F288								
F289								
F290								
F291								
F292								
F293								
F294								
F295								
F296								
F297								
F298	TDF8	TDF7	TDF6	TDF5	TDF4	TDF3	TDF2	TDF1
F299								

	7	6	5	4	3	2	1	0
F300								
F301								
F302								
F303								
F304								
F305								
F306								
F307								
F308								
F309								
F310								
F311								
F312								
F313								
F314								
F315								

A.1.2 Series 16i/18i/160i/180i/ 160is/180is List of Addresses (Two-path Control)

Interface addresses among CNC, PMC and Machine Tool are as follows:

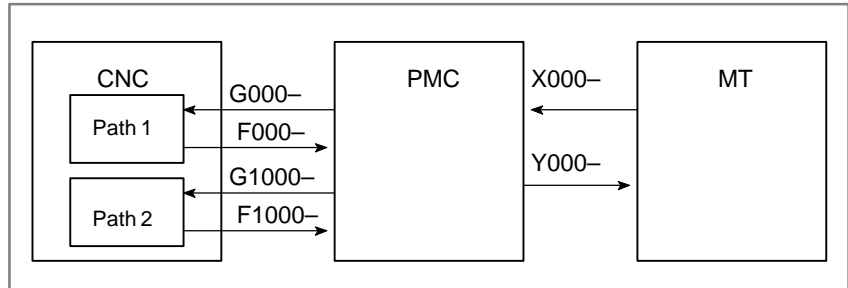

Signals addresses for each path are usually assigned as follows:

Signal address	Contents
G000–G512	Signals on path 1(PMC→CNC)
F000–F512	Signals on path 1(CNC→PMC)
G1000–G1512	Signals on path 2(PMC→CNC)
F1000–F1512	Signals on path 2(CNC→PMC)

However, for the signals common to both paths, those signals are assigned to path 1. Interface signals between the CNC and PMC are as shown below:

The signals with suffix #1 are those for path 1 and the signals with suffix #2 are those for path 2.

MT → PMC

Address	Bit number								
	7	6	5	4	3	2	1	0	
X000									
X001									
X002									
X003									
X004	SKIP #1	ESKIP SKIP6 #1	-MIT2 #1 SKIP5 #1	+MIT2 #1 SKIP4 #1	-MIT1 #1 SKIP3 #1	+MIT1 #1 SKIP2 #1	ZAE #1 SKIP8 #1	XAE #1 SKIP7 #1	(T series)
	SKIP #1	ESKIP SKIP6 #1	SKIP5 #1	SKIP4 #1	SKIP3 #1	ZAE #1 SKIP2 #1	YAE #1 SKIP8 #1	XAE #1 SKIP7 #1	(M series)
X005									
X006									
X007	*DEC8 #2	*DEC7 #2	*DEC6 #2	*DEC5 #2	*DEC4 #2	*DEC3 #2	*DEC2 #2	*DEC1 #2	
X008				*ESP					
X009	*DEC8 #1	*DEC7 #1	*DEC6 #1	*DEC5 #1	*DEC4 #1	*DEC3 #1	*DEC2 #1	*DEC1 #1	
X010									
X011									
X012									
X013	SKIP #2	SKIP6 #2	-MIT2 #2 SKIP5 #2	+MIT2 #2 SKIP4 #2	-MIT1 #2 SKIP3 #2	+MIT1 #2 SKIP2 #2	ZAE #2 SKIP8 #2	XAE #2 SKIP7 #2	(T series)
	SKIP #2	SKIP6 #2	SKIP5 #2	SKIP4 #2	SKIP3 #2	ZAE #2 SKIP2 #2	YAE #2 SKIP8 #2	XAE #2 SKIP7 #2	(M series)

PMC → CNC Path 1

Address	Bit number							
	7	6	5	4	3	2	1	0
G000	ED7 #1	ED6 #1	ED5 #1	ED4 #1	ED3 #1	ED2 #1	ED1 #1	ED0 #1
G001	ED15 #1	ED14 #1	ED13 #1	ED12 #1	ED11 #1	ED10 #1	ED9 #1	ED8 #1
G002	ESTB #1	EA6 #1	EA5 #1	EA4 #1	EA3 #1	EA2 #1	EA1 #1	EA0 #1
G003								
G004			MFIN3 #1	MFIN2 #1	FIN #1			
G005	BFIN #1	AFL #1		BFIN #1	TFIN #1	SFIN #1	EFIN #1	MFIN #1
G006		SKIPP #1		OVC #1		*ABSM #1		SRN #1
G007	RLSOT #1	EXLM #1	*FLWP #1	RLSOT3 #1		ST #1	STLK #1	RVS #1
G008	ERS #1	RRW #1	*SP #1	*ESP #1	*BSL #1		*CSL #1	*IT #1
G009				PN16 #1	PN8 #1	PN4 #1	PN2 #1	PN1 #1
G010	*JV7 #1	*JV6 #1	*JV5 #1	*JV4 #1	*JV3 #1	*JV2 #1	*JV1 #1	*JV0 #1
G011	*JV15 #1	*JV14 #1	*JV13 #1	*JV12 #1	*JV11 #1	*JV10 #1	*JV9 #1	*JV8 #1
G012	*FV7 #1	*FV6 #1	*FV5 #1	*FV4 #1	*FV3 #1	*FV2 #1	*FV1 #1	*FV0 #1
G013	*AFV7 #1	*AFV6 #1	*AFV5 #1	*AFV4 #1	*AFV3 #1	*AFV2 #1	*AFV1 #1	*AFV0 #1
G014							ROV2 #1	ROV1 #1
G015								
G016	F1D #1							MSDFON #1
G017								
G018	HS2D #1	HS2C #1	HS2B #1	HS2A #1	HS1D #1	HS1C #1	HS1B #1	HS1A #1
G019	RT #1		MP2 #1	MP1 #1	HS3D #1	HS3C #1	HS3B #1	HS3A #1
G020								
G021								
G022								
G023	ALNGH #1	RGHTH #1						
G024	EPN7 #1	EPN6 #1	EPN5 #1	EPN4 #1	EPN3 #1	EPN2 #1	EPN1 #1	EPN0 #1

	7	6	5	4	3	2	1	0
G025	EPNS#1		EPN13#1	EPN12#1	EPN11#1	EPN10#1	EPN9#1	EPN8#1
G026		*SSTP4#1			SWS4#1		PC4SLC#1	PC3SLC#1
G027	CON #1		*SSTP3#1	*SSTP2#1	*SSTP1#1	SWS3 #1	SWS2 #1	SWS1 #1
G028	PC2SLC#1	SPSTP#1	*SCPF#1	*SUCPF#1		GR2 #1	GR1 #1	
G029		*SSTP#1	SOR #1	SAR #1		GR31 #1		GR21 #1
G030	SOV7 #1	SOV6 #1	SOV5 #1	SOV4 #1	SOV3 #1	SOV2 #1	SOV1 #1	SOV0 #1
G031	PKESS2#1	PKESS1#1		GR4I#1				
G032	R08I #1	R07I #1	R06I #1	R05I #1	R04I #1	R03I #1	R02I #1	R01I #1
G033	SIND #1	SSIN #1	SGN #1		R12I #1	R11I #1	R10I #1	R09I #1
G034	R08I2 #1	R07I2 #1	R06I2 #1	R05I2 #1	R04I2 #1	R03I2 #1	R02I2 #1	R01I2 #1
G035	SIND2#1	SSIN2#1	SGN2#1		R12I2 #1	R11I2 #1	R10I2 #1	R09I2 #1
G036	R08I3 #1	R07I3 #1	R06I3 #1	R05I3 #1	R04I3 #1	R03I3 #1	R02I3 #1	R01I3 #1
G037	SIND3#1	SSIN3#1	SGN3#1		R12I3 #1	R11I3 #1	R10I3 #1	R09I3 #1
G038	*BECLP #1	*BEUCP #1			SPPHS SPPHS #1	SPSYC SPSYC #1		*PLSST#1
G039	GOQSM#1	WOQSM#1	OFN5 #1	OFN4 #1	OFN3 #1	OFN2 #1	OFN1 #1	OFN0 #1
G040	WOSET #1	PRC #1	S2TLS#1					OFN6 #1
G041	HS2ID#1	HS2IC#1	HS2IB#1	HS2IA#1	HS1ID#1	HS1IC#1	HS1IB#1	HS1IA#1
G042					HS3ID#1	HS3IC#1	HS3IB#1	HS3IA#1
G043	ZRN #1		DNCI #1			MD4 #1	MD2 #1	MD1 #1
G044							MLK #1	BDT1 #1
G045	BDT9 #1	BDT8 #1	BDT7 #1	BDT6 #1	BDT5 #1	BDT4 #1	BDT3 #1	BDT2 #1
G046	DRN #1	KEY4 #1	KEY3 #1	KEY2 #1	KEY1 #1		SBK #1	KEYPRM#1
G047	TL128 #1	TL64 #1	TL32 #1	TL16 #1	TL08 #1	TL04 #1	TL02 #1	TL01 #1
G048	TLRST#1	TLRSTI#1	TLSKP#1					TL256 #1
G049	*TLV7 #1	*TLV6 #1	*TLV5 #1	*TLV4#1	*TLV3 #1	*TLV2 #1	*TLV1 #1	*TLV0 #1

	7	6	5	4	3	2	1	0
G050							*TLV9 #1	*TLV8 #1
G051	*CHLD #1	CHPST #1			*CHP8 #1	*CHP4 #1	*CHP2 #1	*CHP0 #1
G052								
G053	CDZ #1	SMZ #1			UINT #1			TMRON #1
G054	UI007 #1	UI006 #1	UI005 #1	UI004 #1	UI003 #1	UI002 #1	UI001 #1	UI000 #1
G055	UI015 #1	UI014 #1	UI013 #1	UI012 #1	UI011 #1	UI010 #1	UI009 #1	UI008 #1
G056	UI023 #1	UI022 #1	UI021 #1	UI020 #1	UI019 #1	UI018 #1	UI017 #1	UI016 #1
G057	UI031 #1	UI030 #1	UI029 #1	UI028 #1	UI027 #1	UI026 #1	UI025 #1	UI024 #1
G058					EXWT #1	EXSTP #1	EXRD #1	MINP #1
G059							TRRTN #1	TRESC #1
G060	*TSB #1							
G061			RGTS2 #1	RGTS1 #1				RGTA #1
G062		RTNT #1	PDT2 #1	PDT1 #1			*CRTOF #1	
G063		INFD #1	NOZAGC #1		SLSPB	SLSPA	NOWT	HEAD
G064		ESRSYC #1			SLPCB	SLPCA		
G065	HCSKP4 #1	HCSKP3 #1	HCSKP2 #1	HCSKP1 #1				
G066	EKSET		MSPC #1	RTRCT #1		HOBCAN #1	ENBKY	IGNVRY #1
G067								
G068								
G069								
G070	MRDYA #1	ORCMA #1	SFRA #1	SRVA #1	CTH1A #1	CTH2A #1	TLMHA #1	TLMLA #1
G071	RCHA #1	RSLA #1	INTGA #1	SOCNA #1	MCFNA #1	SPSLA #1	*ESPA #1	ARSTA #1
G072	RCHGA #1	MFNHGA #1	INCMDA #1	OVRA #1	DEFMDA #1	NRROA #1	ROTA #1	INDXA #1
G073				DSCNA #1	SORSLA #1	MPOFA #1	SLVA #1	MORCMA #1
G074	MRDYB #1	ORCMB #1	SFRB #1	SRVB #1	CTH1B #1	CTH2B #1	TLMHB #1	TLMLB #1

	7	6	5	4	3	2	1	0
G075	RCHB#1	RSLB#1	INTGB#1	SOCNB#1	MCFNB#1	SPSLB#1	*ESPB#1	ARSTB#1
G076	RCHHGB#1	MFNHGB#1	INCMDB#1	OVRB#1	DEFMDB#1	NRROB#1	ROTAB#1	INDXB#1
G077				DSCNB#1	SORSLB#1	MPOFB#1	SLVB#1	MORCMB#1
G078	SHA07#1	SHA06#1	SHA05#1	SHA04#1	SHA03#1	SHA02#1	SHA01#1	SHA00#1
G079					SHA11#1	SHA10#1	SHA09#1	SHA08#1
G080	SHB07#1	SHB06#1	SHB05#1	SHB04#1	SHB03#1	SHB02#1	SHB01#1	SHB00#1
G081					SHB11#1	SHB10#1	SHB09#1	SHB08#1
G082	Reserved for order made macro							
G083	Reserved for order made macro							
G084								
G085								
G086								
G087								
G088								
G089								
G090	G2SLC#1	G2Y#1	G2Z#1	G2X#1		G2RVY#1	G2RVZ#1	G2RVX#1
G091					SRLNI3#1	SRLNI2#1	SRLNI1#1	SRLNI0#1
G092				BGEN#1	BGIALM#1	BGION#1	IOLS#1	IOLACK#1
G093								
G094								
G095								
G096	HROV#1	*HROV6#1	*HROV5#1	*HROV4#1	*HROV3#1	*HROV2#1	*HROV1#1	*HROV0#1
G097								
G098	EKC7	EKC6	EKC5	EKC4	EKC3	EKC2	EKC1	EKC0
G099								

	7	6	5	4	3	2	1	0
G100	+J8 #1	+J7 #1	+J6 #1	+J5 #1	+J4 #1	+J3 #1	+J2 #1	+J1 #1
G101								
G102	-J8 #1	-J7 #1	-J6 #1	-J5 #1	-J4 #1	-J3 #1	-J2 #1	-J1 #1
G103								
G104	+EXL8 #1	+EXL7 #1	+EXL6 #1	+EXL5 #1	+EXL4 #1	+EXL3 #1	+EXL2 #1	+EXL1 #1
G105	-EXL8 #1	-EXL7 #1	-EXL6 #1	-EXL5 #1	-EXL4 #1	-EXL3 #1	-EXL2 #1	-EXL1 #1
G106	MI8 #1	MI7 #1	MI6 #1	MI5 #1	MI4 #1	MI3 #1	MI2 #1	MI1 #1
G107								
G108	MLK8 #1	MLK7 #1	MLK6 #1	MLK5 #1	MLK4 #1	MLK3 #1	MLK2 #1	MLK1 #1
G109								
G110	+LM8 #1	+LM7 #1	+LM6 #1	+LM5 #1	+LM4 #1	+LM3 #1	+LM2 #1	+LM1 #1
G111								
G112	-LM8 #1	-LM7 #1	-LM6 #1	-LM5 #1	-LM4 #1	-LM3 #1	-LM2 #1	-LM1 #1
G113								
G114	*+L8 #1	*+L7 #1	*+L6 #1	*+L5 #1	*+L4 #1	*+L3 #1	*+L2 #1	*+L1 #1
G115								
G116	*-L8 #1	*-L7 #1	*-L6 #1	*-L5 #1	*-L4 #1	*-L3 #1	*-L2 #1	*-L1 #1
G117								
G118	*+ED8 #1	*+ED7 #1	*+ED6 #1	*+ED5 #1	*+ED4 #1	*+ED3 #1	*+ED2 #1	*+ED1 #1
G119								
G120	*-ED8 #1	*-ED7 #1	*-ED6 #1	*-ED5 #1	*-ED4 #1	*-ED3 #1	*-ED2 #1	*-ED1 #1
G121								
G122	PKESS2 #1	PK7 #1	PK6 #1	PK5 #1	PK4 #1	PK3 #1	PK2 #1	PK1 #1
	PKESS2 #1	PKESS1 #1						
G123								

(T series)
(M series)

	7	6	5	4	3	2	1	0
G124	DTCH8 #1	DTCH7 #1	DTCH6 #1	DTCH5 #1	DTCH4 #1	DTCH3 #1	DTCH2 #1	DTCH1 #1
G125	IUDD8 #1	IUDD7 #1	IUDD6 #1	IUDD5 #1	IUDD4 #1	IUDD3 #1	IUDD2 #1	IUDD1 #1
G126	SVF8 #1	SVF7 #1	SVF6 #1	SVF5 #1	SVF4 #1	SVF3 #1	SVF2 #1	SVF1 #1
G127								
G128	MIX8	MIX7	MIX6	MIX5	MIX4	MIX3	MIX2	MIX1
G129								
G130	*IT8 #1	*IT7 #1	*IT6 #1	*IT5 #1	*IT4 #1	*IT3 #1	*IT2 #1	*IT1 #1
G131								
G132					+MIT4 #1	+MIT3 #1	+MIT2 #1	+MIT1 #1
G133								
G134					-MIT4 #1	-MIT3 #1	-MIT2 #1	-MIT1 #1
G135								
G136	EAX8 #1	EAX7 #1	EAX6 #1	EAX5 #1	EAX4 #1	EAX3 #1	EAX2 #1	EAX1 #1
G137								
G138	SYNC8 #1	SYNC7 #1	SYNC6 #1	SYNC5 #1	SYNC4 #1	SYNC3 #1	SYNC2 #1	SYNC1 #1
G139								
G140	SYNCJ8 #1	SYNCJ7 #1	SYNCJ6 #1	SYNCJ5 #1	SYNCJ4 #1	SYNCJ3 #1	SYNCJ2 #1	SYNCJ1 #1
G141								
G142	EBUFA #1	ECLRA #1	ESTPA #1	ESOFA #1	ESBKA #1	EMBUFA #1	ELCKZA #1	EFINA #1
G143	EMSBKA #1	EC6A #1	EC5A #1	EC4A #1	EC3A #1	EC2A #1	EC1A #1	EC0A #1
G144	EIF7A #1	EIF6A #1	EIF5A #1	EIF4A #1	EIF3A #1	EIF2A #1	EIF1A #1	EIF0A #1
G145	EIF15A #1	EIF14A #1	EIF13A #1	EIF12A #1	EIF11A #1	EIF10A #1	EIF9A #1	EIF8A #1
G146	EID7A #1	EID6A #1	EID5A #1	EID4A #1	EID3A #1	EID2A #1	EID1A #1	EID0A #1
G147	EID15A #1	EID14A #1	EID13A #1	EID12A #1	EID11A #1	EID10A #1	EID9A #1	EID8A #1
G148	EID23A #1	EID22A #1	EID21A #1	EID20A #1	EID19A #1	EID18A #1	EID17A #1	EID16A #1

	7	6	5	4	3	2	1	0
G149	EID31A#1	EID30A#1	EID29A#1	EID28A#1	EID27A#1	EID26A#1	EID25A#1	EID24A#1
G150	DRNE#1	RTE #1	OVCE#1				ROV2E#1	ROV1E#1
G151	*FV7E#1	*FV6E#1	*FV5E#1	*FV4E#1	*FV3E#1	*FV2E#1	*FV1E#1	*FV0E#1
G152								
G153								
G154	EBUFB#1	ECLRB#1	ESTPB#1	ESOFB#1	ESBKB#1	EMBUFB#1	ELCKZB#1	EFINB#1
G155	EMSBKB#1	EC6B #1	EC5B #1	EC4B #1	EC3B #1	EC2B #1	EC1B #1	EC0B #1
G156	EIF7B#1	EIF6B#1	EIF5B#1	EIF4B#1	EIF3B#1	EIF2B#1	EIF1B#1	EIF0B#1
G157	EIF15B#1	EIF14B#1	EIF13B#1	EIF12B#1	EIF11B#1	EIF10B#1	EIF9B#1	EIF8B#1
G158	EID7B#1	EID6B#1	EID5B#1	EID4B#1	EID3B#1	EID2B#1	EID1B#1	EID0B#1
G159	EID15B#1	EID14B#1	EID13B#1	EID12B#1	EID11B#1	EID10B#1	EID9B#1	EID8B#1
G160	EID23B#1	EID22B#1	EID21B#1	EID20B#1	EID19B#1	EID18B#1	EID17B#1	EID16B#1
G161	EID31B#1	EID30B#1	EID29B#1	EID28B#1	EID27B#1	EID26B#1	EID25B#1	EID24B#1
G162								
G163								
G164								
G165								
G166	EBUFC#1	ECLRC#1	ESTPC#1	ESOFB#1	ESBKC#1	EMBUFC#1	ELCKZC#1	EFINC#1
G167	EMSBKC#1	EC6C #1	EC5C #1	EC4C #1	EC3C #1	EC2C #1	EC1C #1	EC0C #1
G168	EIF7C#1	EIF6C#1	EIF5C#1	EIF4C#1	EIF3C#1	EIF2C#1	EIF1C#1	EIF0C#1
G169	EIF15C#1	EIF14C#1	EIF13C#1	EIF12C#1	EIF11C#1	EIF10C#1	EIF9C#1	EIF8C#1
G170	EID7C#1	EID6C#1	EID5C#1	EID4C#1	EID3C#1	EID2C#1	EID1C#1	EID0C#1
G171	EID15C#1	EID14C#1	EID13C#1	EID12C#1	EID11C#1	EID10C#1	EID9C#1	EID8C#1
G172	EID23C#1	EID22C#1	EID21C#1	EID20C#1	EID19C#1	EID18C#1	EID17C#1	EID16C#1
G173	EID31C#1	EID30C#1	EID29C#1	EID28C#1	EID27C#1	EID26C#1	EID25C#1	EID24C#1

	7	6	5	4	3	2	1	0
G174								
G175								
G176								
G177								
G178	EBUFD #1	ECLRD #1	ESTPD #1	ESOFD #1	ESBKD #1	EMBUFD #1	ELCKZD #1	EFIND #1
G179	EMSBKD #1	EC6D #1	EC5D #1	EC4D #1	EC3D #1	EC2D #1	EC1D #1	EC0D #1
G180	EIF7D #1	EIF6D #1	EIF5D #1	EIF4D #1	EIF3D #1	EIF2D #1	EIF1D #1	EIF0D #1
G181	EIF15D #1	EIF14D #1	EIF13D #1	EIF12D #1	EIF11D #1	EIF10D #1	EIF9D #1	EIF8D #1
G182	EID7D #1	EID6D #1	EID5D #1	EID4D #1	EID3D #1	EID2D #1	EID1D #1	EID0D #1
G183	EID15D #1	EID14D #1	EID13D #1	EID12D #1	EID11D #1	EID10D #1	EID9D #1	EID8D #1
G184	EID23D #1	EID22D #1	EID21D #1	EID20D #1	EID19D #1	EID18D #1	EID17D #1	EID16D #1
G185	EID31D #1	EID30D #1	EID29D #1	EID28D #1	EID27D #1	EID26D #1	EID25D #1	EID24D #1
G186								
G187								
G188								
G189								
G190	OVLS8 #1	OVLS7 #1	OVLS6 #1	OVLS5 #1	OVLS4 #1	OVLS3 #1	OVLS2 #1	OVLS1 #1
G191								
G192	IGVRY8 #1	IGVRY7 #1	IGVRY6 #1	IGVRY5 #1	IGVRY4 #1	IGVRY3 #1	IGVRY2 #1	IGVRY1 #1
G193								
G194								
G195								
G196								
G197								
G198	NPOS8 #1	NPOS7 #1	NPOS6 #1	NPOS5 #1	NPOS4 #1	NPOS3 #1	NPOS2 #1	NPOS1 #1

	7	6	5	4	3	2	1	0
G199								
G200	EASIP8#1	EASIP7#1	EASIP6#1	EASIP5#1	EASIP4#1	EASIP3#1	EASIP2#1	EASIP1#1
G201			JGRD3#1	JGRD2#1	JGRD1#1			
G202								
G203								
G204	MRDYC#1	ORCMC#1	SFRC#1	SRVC#1	CTH1C#1	CTH2C#1	TLMHC#1	TLMLC#1
G205	RCHC#1	RSLC#1	INTGC#1	SOCNC#1	MCFNC#1	SPSLC#1	*ESPC#1	ARSTC#1
G206	RCHHGC#1	MFNHGC#1	INCMDC#1	OVRC#1	DEFMDC#1	NRROC#1	ROTBC#1	INDXC#1
G207				DSCNC#1	SORSLC#1	MPOFC#1	SLVC#1	MORCMC#1
G208								
G209								
G210								
G211								
G212								
G213								
G214								
G215								
G216								
G217								
G218								
G219								
G220								
G221								
G222								
G223								

	7	6	5	4	3	2	1	0
G224								
G225								
G226								
G227								
G228								
G229								
G230								
G231								
G232								
G233								
G234								
G235								
G236								
G237								
G238								
G239								
G240								
G241								
G242								
G243								
G244								
G245								
G246								
G247								
G248								

	7	6	5	4	3	2	1	0
G249								
G250								
G251								
G252								
G253								
G254								
G255								
G256								
G257								
G258								
G259								
G260								
G261								
G262								
G263								
G264								
G265								
G266	MRDYD#1	ORCMD#1	SFRD#1	SRVD#1	CTH1D#1	CTH2D#1	TLMHD#1	TLMLD#1
G267	RCHD#1	RSLD#1	INTGD#1	SOCND#1	MCFND#1	SPSLD#1	*ESPD#1	ARSTD#1
G268	RCHGHD#1	MFNHGD#1	INCMDD#1	OVRD#1	DEFMDD#1	NRROD#1	ROTB#1	INDXD#1
G269				DSCND#1	SORSLD#1	MPOFD#1	SLVD#1	MORCMD#1
G270	SHD07#1	SHD06#1	SHD05#1	SHD04#1	SHD03#1	SHD02#1	SHD01#1	SHD00#1
G271					SHD11#1	SHD10#1	SHD09#1	SHD08#1
G272	R08I4#1	R07I4#1	R06I4#1	R05I4#1	R04I4#1	R03I4#1	R02I4#1	R01I4#1
G273	SIND4#1	SSIN4#1	SGN4#1		R12I4#1	R11I4#1	R10I4#1	R09I4#1

	7	6	5	4	3	2	1	0
G274								
G275								
G276	UI107 #1	UI106 #1	UI105 #1	UI104 #1	UI103 #1	UI102 #1	UI101 #1	UI100 #1
G277	UI115 #1	UI114 #1	UI113 #1	UI112 #1	UI111 #1	UI110 #1	UI109 #1	UI108 #1
G278	UI123 #1	UI122 #1	UI121 #1	UI120 #1	UI119 #1	UI118 #1	UI117 #1	UI116 #1
G279	UI131 #1	UI130 #1	UI129 #1	UI128 #1	UI127 #1	UI126 #1	UI125 #1	UI124 #1
G280	UI207 #1	UI206 #1	UI205 #1	UI204 #1	UI203 #1	UI202 #1	UI201 #1	UI200 #1
G281	UI215 #1	UI214 #1	UI213 #1	UI212 #1	UI211 #1	UI210 #1	UI209 #1	UI208 #1
G282	UI223 #1	UI222 #1	UI221 #1	UI220 #1	UI219 #1	UI218 #1	UI217 #1	UI216 #1
G283	UI231 #1	UI230 #1	UI229 #1	UI228 #1	UI227 #1	UI226 #1	UI225 #1	UI224 #1
G284	UI307 #1	UI306 #1	UI305 #1	UI304 #1	UI303 #1	UI302 #1	UI301 #1	UI300 #1
G285	UI315 #1	UI314 #1	UI313 #1	UI312 #1	UI311 #1	UI310 #1	UI309 #1	UI308 #1
G286	UI323 #1	UI322 #1	UI321 #1	UI320 #1	UI319 #1	UI318 #1	UI317 #1	UI316 #1
G287	UI331 #1	UI330 #1	UI329 #1	UI328 #1	UI327 #1	UI326 #1	UI325 #1	UI324 #1
G288								
G289								
G290								
G291								
G292	ITCD #1							
G293								
G294								
G295								
G296								
G297								
G298	TDF8 #1	TDF7 #1	TDF6 #1	TDF5 #1	TDF4 #1	TDF3 #1	TDF2 #1	TDF1 #1

	7	6	5	4	3	2	1	0
G299								
G300								
G301								
G302								
G303								
G304								
G305								
G306								
G307								
G308								
G309								
G310								
G311								
G312								
G313								
G314								
G315								
G316								
G317								
G318								
G319								

PMC → CNC Path 2

Address	Bit number							
	7	6	5	4	3	2	1	0
G1000	ED7#2	ED6#2	ED5#2	ED4#2	ED3#2	ED2#2	ED1#2	ED0#2
G1001	ED15#2	ED14#2	ED13#2	ED12#2	ED11#2	ED10#2	ED9#2	ED8#2
G1002	ESTB#2	EA6#2	EA5#2	EA4#2	EA3#2	EA2#2	EA1#2	EA0#2
G1003								
G1004			MFIN3#2	MFIN2#2	FIN#2			
G1005	BFIN#2	AFL#2		BFIN#2	TFIN#2	SFIN#2	EFIN#2	MFIN#2
G1006		SKIPP#2		OVC#2		*ABSM#2		SRN#2
G1007	RLSOT#2	EXLM#2	*FLWP#2	RLSOT3#2		ST#2	STLK#2	RVS#2
G1008	ERS#2	RRW#2	*SP#2	*ESP#2	*BSL#2		*CSL#2	*IT#2
G1009				PN16#2	PN8#2	PN4#2	PN2#2	PN1#2
G1010	*JV7#2	*JV6#2	*JV5#2	*JV4#2	*JV3#2	*JV2#2	*JV1#2	*JV0#2
G1011	*JV15#2	*JV14#2	*JV13#2	*JV12#2	*JV11#2	*JV10#2	*JV9#2	*JV8#2
G1012	*FV7#2	*FV6#2	*FV5#2	*FV4#2	*FV3#2	*FV2#2	*FV1#2	*FV0#2
G1013	*AFV7#2	*AFV6#2	*AFV5#2	*AFV4#2	*AFV3#2	*AFV2#2	*AFV1#2	*AFV0#2
G1014							ROV2#2	ROV1#2
G1015								
G1016	F1D#2							MSDFON#2
G1017								
G1018	HS2D#2	HS2C#2	HS2B#2	HS2A#2	HS1D#2	HS1C#2	HS1B#2	HS1A#2
G1019	RT#2		MP2#2	MP1#2	HS3D#2	HS3C#2	HS3B#2	HS3A#2
G1020								
G1021								
G1022								
G1023	ALNGH#2	RGHTH#2						
G1024	EPN7#2	EPN6#2	EPN5#2	EPN4#2	EPN3#2	EPN2#2	EPN1#2	EPN0#2

	7	6	5	4	3	2	1	0
G1025	EPNS#2		EPN13#2	EPN12#2	EPN11#2	EPN10#2	EPN9#2	EPN8#2
G1026		*SSTP4#2			SWS4#2		PC4SLC#2	PC3SLC#2
G1027	CON#2		*SSTP3#2	*SSTP2#2	*SSTP1#2	SWS3#2	SWS2#2	SWS1#2
G1028	PC2SLC#2	SPSTP#2	*SCPF#2	*SUCPF#2		GR2#2	GR1#2	
G1029		*SSTP#2	SOR#2	SAR#2		GR31#2		GR21#2
G1030	SOV7#2	SOV6#2	SOV5#2	SOV4#2	SOV3#2	SOV2#2	SOV1#2	SOV0#2
G1031	PKESS2#2	PKESS1#2		GR41#2				
G1032	R081#2	R071#2	R061#2	R051#2	R041#2	R031#2	R021#2	R011#2
G1033	SIND#2	SSIN#2	SGN#2		R121#2	R111#2	R101#2	R091#2
G1034	R0812#2	R0712#2	R0612#2	R0512#2	R0412#2	R0312#2	R0212#2	R0112#2
G1035	SIND2#2	SSIN2#2	SGN2#2		R1212#2	R1112#2	R1012#2	R0912#2
G1036	R0813#2	R0713#2	R0613#2	R0513#2	R0413#2	R0313#2	R0213#2	R0113#2
G1037	SIND3#2	SSIN3#2	SGN3#2		R1213#2	R1113#2	R1013#2	R0913#2
G1038	*BECLP#2	*BEUCP#2			SPPHS#2	SPSYC#2		*PLSST#2
G1039	GOQSM#2	WOQSM#2	OFN5#2	OFN4#2	OFN3#2	OFN2#2	OFN1#2	OFN0#2
G1040	WOSET#2	PRC#2	S2TLS#2					OFN6#2
G1041	HS2ID#2	HS2IC#2	HS2IB#2	HS2IA#2	HS1ID#2	HS1IC#2	HS1IB#2	HS1IA#2
G1042					HS3ID#2	HS3IC#2	HS3IB#2	HS3IA#2
G1043	ZRN#2		DNC1#2			MD4#2	MD2#2	MD1#2
G1044							MLK#2	BDT1#2
G1045	BDT9#2	BDT8#2	BDT7#2	BDT6#2	BDT5#2	BDT4#2	BDT3#2	BDT2#2
G1046	DRN#2	KEY4#2	KEY3#2	KEY2#2	KEY1#2		SBK#2	KEYPRM#2
G1047	TL128#2	TL64#2	TL32#2	TL16#2	TL08#2	TL04#2	TL02#2	TL01#2
G1048	TLRST#2	TLRST1#2	TLSKP#2					TL256#2
G1049	*TLV7#2	*TLV6#2	*TLV5#2	*TLV4#2	*TLV3#2	*TLV2#2	*TLV1#2	*TLV0#2

	7	6	5	4	3	2	1	0
G1050							*TLV9 #2	*TLV8 #2
G1051	*CHLD #2	CHPST #2			*CHP8 #2	*CHP4 #2	*CHP2 #2	*CHP0 #2
G1052								
G1053	CDZ #2	SMZ #2			UINT #2			TMRON #2
G1054	UI007 #2	UI006 #2	UI005 #2	UI004 #2	UI003 #2	UI002 #2	UI001 #2	UI000 #2
G1055	UI015 #2	UI014 #2	UI013 #2	UI012 #2	UI011 #2	UI010 #2	UI009 #2	UI008 #2
G1056	UI023 #2	UI022 #2	UI021 #2	UI020 #2	UI019 #2	UI018 #2	UI017 #2	UI016 #2
G1057	UI031 #2	UI030 #2	UI029 #2	UI028 #2	UI027 #2	UI026 #2	UI025 #2	UI024 #2
G1058					EXWT #2	EXSTP #2	EXRD #2	MINP #2
G1059							TRRTN #2	TRESC #2
G1060	*TSB #2							
G1061			RGTS2 #2	RGTS1 #2				RGTA #2
G1062		RTNT #2	PDT2 #2	PDT1 #2			*CRTOF #2	
G1063		INFD #2	NOZAGC #2					
G1064		ESRSYC #2						
G1065	HCSKP4 #2	HCSKP3 #2	HCSKP2 #2	HCSKP1 #2				
G1066			MSPC #2	RTRCT #2		HOBCAN #2		IGNVRY #2
G1067								
G1068								
G1069								
G1070	MRDYA #2	ORCMA #2	SFRA #2	SRVA #2	CTH1A #2	CTH2A #2	TLMHA #2	TLMLA #2
G1071	RCHA #2	RSLA #2	INTGA #2	SOCNA #2	MCFNA #2	SPSLA #2	*ESPA #2	ARSTA #2
G1072	RCHGA #2	MFHGA #2	INCMDA #2	OVRA #2	DEFMDA #2	NRROA #2	ROTA #2	INDXA #2
G1073				DSCNA #2	SORSLA #2	MPOFA #2	SLVA #2	MORCMA #2
G1074	MRDYB #2	ORCMB #2	SFRB #2	SRVB #2	CTH1B #2	CTH2B #2	TLMHB #2	TLMLB #2

	7	6	5	4	3	2	1	0
G1075	RCHB #2	RSLB #2	INTGB #2	SOCNB #2	MCFNB #2	SPSLB #2	*ESPB #2	ARSTB #2
G1076	RCHHGB #2	MFNHGB #2	INCMDB #2	OVRB #2	DEFMDB #2	NRROB #2	ROTAB #2	INDXB #2
G1077				DSCNB #2	SORSLB #2	MPOFB #2	SLVB #2	MORCMB #2
G1078	SHA07 #2	SHA06 #2	SHA05 #2	SHA04 #2	SHA03 #2	SHA02 #2	SHA01 #2	SHA00 #2
G1079					SHA11 #2	SHA10 #2	SHA09 #2	SHA08 #2
G1080	SHB07 #2	SHB06 #2	SHB05 #2	SHB04 #2	SHB03 #2	SHB02 #2	SHB01 #2	SHB00 #2
G1081					SHB11 #2	SHB10 #2	SHB09 #2	SHB08 #2
G1082	Reserved for order made macro							
G1083	Reserved for order made macro							
G1084								
G1085								
G1086								
G1087								
G1088								
G1089								
G1090	G2SLC #2	G2Y #2	G2Z #2	G2X #2		G2RVY #2	G2RVZ #2	G2RVX #2
G1091					SRLNI3 #2	SRLNI2 #2	SRLNI1 #2	SRLNI0 #2
G1092				BGEN #2	BGIALM #2	BGION #2	IOLS #2	IOLACK #2
G1093								
G1094								
G1095								
G1096	HROV #2	*HROV6 #2	*HROV5 #2	*HROV4 #2	*HROV3 #2	*HROV2 #2	*HROV1 #2	*HROV0 #2
G1097								
G1098								
G1099								

	7	6	5	4	3	2	1	0
G1100	+J8#2	+J7#2	+J6#2	+J5#2	+J4#2	+J3#2	+J2#2	+J1#2
G1101								
G1102	-J8#2	-J7#2	-J6#2	-J5#2	-J4#2	-J3#2	-J2#2	-J1#2
G1103								
G1104	+EXL8#2	+EXL7#2	+EXL6#2	+EXL5#2	+EXL4#2	+EXL3#2	+EXL2#2	+EXL1#2
G1105	-EXL8#2	-EXL7#2	-EXL6#2	-EXL5#2	-EXL4#2	-EXL3#2	-EXL2#2	-EXL1#2
G1106	MI8#2	MI7#2	MI6#2	MI5#2	MI4#2	MI3#2	MI2#2	MI1#2
G1107								
G1108	MLK8#2	MLK7#2	MLK6#2	MLK5#2	MLK4#2	MLK3#2	MLK2#2	MLK1#2
G1109								
G1110	+LM8 #2	+LM7 #2	+LM6 #2	+LM5 #2	+LM4 #2	+LM3 #2	+LM2 #2	+LM1 #2
G1111								
G1112	-LM8 #2	-LM7 #2	-LM6 #2	-LM5 #2	-LM4 #2	-LM3 #2	-LM2 #2	-LM1 #2
G1113								
G1114	*+L8#2	*+L7#2	*+L6#2	*+L5#2	*+L4#2	*+L3#2	*+L2#2	*+L1#2
G1115								
G1116	*-L8#2	*-L7#2	*-L6#2	*-L5#2	*-L4#2	*-L3#2	*-L2#2	*-L1#2
G1117								
G1118	*+ED8#2	*+ED7#2	*+ED6#2	*+ED5#2	*+ED4#2	*+ED3#2	*+ED2#2	*+ED1#2
G1119								
G1120	*-ED8#2	*-ED7#2	*-ED6#2	*-ED5#2	*-ED4#2	*-ED3#2	*-ED2#2	*-ED1#2
G1121								
G1122	PKESS2#2	PK7#2	PK6 #2	PK5 #2	PK4 #2	PK3 #2	PK2 #2	PK1 #2
		PKESS1#2						
	PKESS2#2	PKESS1#2						
G1123								

(T series)

(M series)

	7	6	5	4	3	2	1	0
G1124	DTCH8 #2	DTCH7 #2	DTCH6 #2	DTCH5 #2	DTCH4 #2	DTCH3 #2	DTCH2 #2	DTCH1 #2
G1125	IUDD8 #2	IUDD7 #2	IUDD6 #2	IUDD5 #2	IUDD4 #2	IUDD3 #2	IUDD2 #2	IUDD1 #2
G1126	SVF8 #2	SVF7 #2	SVF6 #2	SVF5 #2	SVF4 #2	SVF3 #2	SVF2 #2	SVF1 #2
G1127								
G1128								
G1129								
G1130	*IT8 #2	*IT7 #2	*IT6 #2	*IT5 #2	*IT4 #2	*IT3 #2	*IT2 #2	*IT1 #2
G1131								
G1132					+MIT4 #2	+MIT3 #2	+MIT2 #2	+MIT1 #2
G1133								
G1134					-MIT4 #2	-MIT3 #2	-MIT2 #2	-MIT1 #2
G1135								
G1136	EAX8 #2	EAX7 #2	EAX6 #2	EAX5 #2	EAX4 #2	EAX3 #2	EAX2 #2	EAX1 #2
G1137								
G1138	SYNC8 #2	SYNC7 #2	SYNC6 #2	SYNC5 #2	SYNC4 #2	SYNC3 #2	SYNC2 #2	SYNC1 #2
G1139								
G1140	SYNCJ8 #2	SYNCJ7 #2	SYNCJ6 #2	SYNCJ5 #2	SYNCJ4 #2	SYNCJ3 #2	SYNCJ2 #2	SYNCJ1 #2
G1141								
G1142	EBUFA #2	ECLRA #2	ESTPA #2	ESOFA #2	ESBKA #2	EMBUFA #2	ELCKZA #2	EFINA #2
G1143	EMSBKA #2	EC6A #2	EC5A #2	EC4A #2	EC3A #2	EC2A #2	EC1A #2	EC0A #2
G1144	EIF7A #2	EIF6A #2	EIF5A #2	EIF4A #2	EIF3A #2	EIF2A #2	EIF1A #2	EIF0A #2
G1145	EIF15A #2	EIF14A #2	EIF13A #2	EIF12A #2	EIF11A #2	EIF10A #2	EIF9A #2	EIF8A #2
G1146	EID7A #2	EID6A #2	EID5A #2	EID4A #2	EID3A #2	EID2A #2	EID1A #2	EID0A #2
G1147	EID15A #2	EID14A #2	EID13A #2	EID12A #2	EID11A #2	EID10A #2	EID9A #2	EID8A #2
G1148	EID23A #2	EID22A #2	EID21A #2	EID20A #2	EID19A #2	EID18A #2	EID17A #2	EID16A #2

	7	6	5	4	3	2	1	0
G1149	EID31A#2	EID30A#2	EID29A#2	EID28A#2	EID27A#2	EID26A#2	EID25A#2	EID24A#2
G1150	DRNE#2	RTE#2	OVCE#2				ROV2E#2	ROV1E#2
G1151	*FV7E#2	*FV6E#2	*FV5E#2	*FV4E#2	*FV3E#2	*FV2E#2	*FV1E#2	*FV0E#2
G1152								
G1153								
G1154	EBUFB#2	ECLRB#2	ESTPB#2	ESOFB#2	ESBKB#2	EMBUFB#2	ELCKZB#2	EFINB#2
G1155	EMSBKB#2	EC6B#2	EC5B#2	EC4B#2	EC3B#2	EC2B#2	EC1B#2	EC0B#2
G1156	EIF7B#2	EIF6B#2	EIF5B#2	EIF4B#2	EIF3B#2	EIF2B#2	EIF1B#2	EIF0B#2
G1157	EIF15B#2	EIF14B#2	EIF13B#2	EIF12B#2	EIF11B#2	EIF10B#2	EIF9B#2	EIF8B#2
G1158	EID7B#2	EID6B#2	EID5B#2	EID4B#2	EID3B#2	EID2B#2	EID1B#2	EID0B#2
G1159	EID15B#2	EID14B#2	EID13B#2	EID12B#2	EID11B#2	EID10B#2	EID9B#2	EID8B#2
G1160	EID23B#2	EID22B#2	EID21B#2	EID20B#2	EID19B#2	EID18B#2	EID17B#2	EID16B#2
G1161	EID31B#2	EID30B#2	EID29B#2	EID28B#2	EID27B#2	EID26B#2	EID25B#2	EID24B#2
G1162								
G1163								
G1164								
G1165								
G1166	EBUFC#2	ECLRC#2	ESTPC#2	ESOFB#2	ESBKC#2	EMBUFC#2	ELCKZC#2	EFINC#2
G1167	EMSBKC#2	EC6C#2	EC5C#2	EC4C#2	EC3C#2	EC2C#2	EC1C#2	EC0C#2
G1168	EIF7C#2	EIF6C#2	EIF5C#2	EIF4C#2	EIF3C#2	EIF2C#2	EIF1C#2	EIF0C#2
G1169	EIF15C#2	EIF14C#2	EIF13C#2	EIF12C#2	EIF11C#2	EIF10C#2	EIF9C#2	EIF8C#2
G1170	EID7C#2	EID6C#2	EID5C#2	EID4C#2	EID3C#2	EID2C#2	EID1C#2	EID0C#2
G1171	EID15C#2	EID14C#2	EID13C#2	EID12C#2	EID11C#2	EID10C#2	EID9C#2	EID8C#2
G1172	EID23C#2	EID22C#2	EID21C#2	EID20C#2	EID19C#2	EID18C#2	EID17C#2	EID16C#2
G1173	EID31C#2	EID30C#2	EID29C#2	EID28C#2	EID27C#2	EID26C#2	EID25C#2	EID24C#2

	7	6	5	4	3	2	1	0
G1174								
G1175								
G1176								
G1177								
G1178	EBUFD#2	ECLRD#2	ESTPD#2	ESOFD#2	ESBKD#2	EMBUFD#2	ELCKZD#2	EFIND#2
G1179	EMSBKD#2	EC6D#2	EC5D#2	EC4D#2	EC3D#2	EC2D#2	EC1D#2	EC0D#2
G1180	EIF7D#2	EIF6D#2	EIF5D#2	EIF4D#2	EIF3D#2	EIF2D#2	EIF1D#2	EIF0D#2
G1181	EIF15D#2	EIF14D#2	EIF13D#2	EIF12D#2	EIF11D#2	EIF10D#2	EIF9D#2	EIF8D#2
G1182	EID7D#2	EID6D#2	EID5D#2	EID4D#2	EID3D#2	EID2D#2	EID1D#2	EID0D#2
G1183	EID15D#2	EID14D#2	EID13D#2	EID12D#2	EID11D#2	EID10D#2	EID9D#2	EID8D#2
G1184	EID23D#2	EID22D#2	EID21D#2	EID20D#2	EID19D#2	EID18D#2	EID17D#2	EID16D#2
G1185	EID31D#2	EID30D#2	EID29D#2	EID28D#2	EID27D#2	EID26D#2	EID25D#2	EID24D#2
G1186								
G1187								
G1188								
G1189								
G1190	OVLS8#2	OVLS7#2	OVLS6#2	OVLS5#2	OVLS4#2	OVLS3#2	OVLS2#2	OVLS1#2
G1191								
G1192	IGVRY8#2	IGVRY7#2	IGVRY6#2	IGVRY5#2	IGVRY4#2	IGVRY3#2	IGVRY2#2	IGVRY1#2
G1193								
G1194								
G1195								
G1196								
G1197								
G1198	NPOS8#2	NPOS7#2	NPOS6#2	NPOS5#2	NPOS4#2	NPOS3#2	NPOS2#2	NPOS1#2

	7	6	5	4	3	2	1	0
G1199								
G1200	EASIP8#2	EASIP7#2	EASIP6#2	EASIP5#2	EASIP4#2	EASIP3#2	EASIP2#2	EASIP1#2
G1201			JGRD3#2	JGRD2#2	JGRD1#2			
G1202								
G1203								
G1204	MRDYC#2	ORCMC#2	SFRC#2	SRVC#2	CTH1C#2	CTH2C#2	TLMHC#2	TLMLC#2
G1205	RCHC#2	RSLC#2	INTGC#2	SOCNC#2	MCFNC#2	SPSLC#2	*ESPC#2	ARSTC#2
G1206	RCHHGC#2	MFNHGC#2	INCMDC#2	OVRC#2	DEFMDC#2	NRROC#2	ROTBC#2	INDXC#2
G1207				DSCNC#2	SORSLC#2	MPOFC#2	SLVC#2	MORCMC#2
G1208								
G1209								
G1210								
G1211								
G1212								
G1213								
G1214								
G1215								
G1216								
G1217								
G1218								
G1219								
G1220								
G1221								
G1222								
G1223								

	7	6	5	4	3	2	1	0
G1224								
G1225								
G1226								
G1227								
G1228								
G1229								
G1230								
G1231								
G1232								
G1233								
G1234								
G1235								
G1236								
G1237								
G1238								
G1239								
G1240								
G1241								
G1242								
G1243								
G1244								
G1245								
G1246								
G1247								
G1248								

	7	6	5	4	3	2	1	0
G1249								
G1250								
G1251								
G1252								
G1253								
G1254								
G1255								
G1256								
G1257								
G1258								
G1259								
G1260								
G1261								
G1262								
G1263								
G1264								
G1265								
G1266	MRDYD#2	ORCMD#2	SFRD#2	SRVD#2	CTH1D#2	CTH2D#2	TLMHD#2	TLMLD#2
G1267	RCHD#2	RSLD#2	INTGD#2	SOCND#2	MCFND#2	SPSLD#2	*ESPD#2	ARSTD#2
G1268	RCHGHD#2	MFNHGD#2	INCMD#2	OVRD#2	DEFMDD#2	NRROD#2	ROTB#2	INDXD#2
G1269				DSCND#2	SORSRD#2	MPOFD#2	SLVD#2	MORCMD#2
G1270	SHD07#2	SHD06#2	SHD05#2	SHD04#2	SHD03#2	SHD02#2	SHD01#2	SHD00#2
G1271					SHD11#2	SHD10#2	SHD09#2	SHD08#2
G1272	R08I4#2	R07I4#2	R06I4#2	R05I4#2	R04I4#2	R03I4#2	R02I4#2	R01I4#2
G1273	SIND4#2	SSIN4#2	SGN4#2		R12I4#2	R11I4#2	R10I4#2	R09I4#2

	7	6	5	4	3	2	1	0
G1274								
G1275								
G276	UI107 #2	UI106 #2	UI105 #2	UI104 #2	UI103 #2	UI102 #2	UI101 #2	UI100 #2
G277	UI115 #2	UI114 #2	UI113 #2	UI112 #2	UI111 #2	UI110 #2	UI109 #2	UI108 #2
G278	UI123 #2	UI122 #2	UI121 #2	UI120 #2	UI119 #2	UI118 #2	UI117 #2	UI116 #2
G279	UI131 #2	UI130 #2	UI129 #2	UI128 #2	UI127 #2	UI126 #2	UI125 #2	UI124 #2
G280	UI207 #2	UI206 #2	UI205 #2	UI204 #2	UI203 #2	UI202 #2	UI201 #2	UI200 #2
G281	UI215 #2	UI214 #2	UI213 #2	UI212 #2	UI211 #2	UI210 #2	UI209 #2	UI208 #2
G282	UI223 #2	UI222 #2	UI221 #2	UI220 #2	UI219 #2	UI218 #2	UI217 #2	UI216 #2
G283	UI231 #2	UI230 #2	UI229 #2	UI228 #2	UI227 #2	UI226 #2	UI225 #2	UI224 #2
G284	UI307 #2	UI306 #2	UI305 #2	UI304 #2	UI303 #2	UI302 #2	UI301 #2	UI300 #2
G285	UI315 #2	UI314 #2	UI313 #2	UI312 #2	UI311 #2	UI310 #2	UI309 #2	UI308 #2
G286	UI323 #2	UI322 #2	UI321 #2	UI320 #2	UI319 #2	UI318 #2	UI317 #2	UI316 #2
G287	UI331 #2	UI330 #2	UI329 #2	UI328 #2	UI327 #2	UI326 #2	UI325 #2	UI324 #2
G1288								
G1289								
G1290								
G1291								
G1292	ITCD#2							
G1293								
G1294								
G1295								
G1296								
G1297								
G1298								

	7	6	5	4	3	2	1	0
G1299								
G1300								
G1301								
G1302								
G1303								
G1304								
G1305								
G1306								
G1307								
G1308								
G1309								
G1310								
G1311								
G1312								
G1313								
G1314								
G1315								
G1316								
G1317								
G1318								
G1319								

CNC Path 1 → PMC

Address	Bit number							
	7	6	5	4	3	2	1	0
F000	OP#1	SA#1	STL#1	SPL#1				RWD#1
F001	MA#1		TAP#1	ENB#1	DEN#1	BAL#1	RST#1	AL#1
F002	MDRN#1	CUT#1		SRNMV#1	THRD#1	CSS#1	RPDO#1	INCH#1
F003	MTCHIN#1	MEDT#1	MMEM#1	MRMT#1	MMDI#1	MJ#1	MH#1	MINC#1
F004			MREF#1	MAFL#1	MSBK#1	MABSM#1	MMLK#1	MBDT1#1
F005	MBDT9#1	MBDT8#1	MBDT7#1	MBDT6#1	MBDT5#1	MBDT4#1	MBDT3#1	MBDT2#1
F006								
F007	BF#1			BF#1	TF#1	SF#1	EFD#1	MF#1
F008			MF3#1	MF2#1				EF#1
F009	DM00#1	DM01#1	DM02#1	DM30#1				
F010	M07#1	M06#1	M05#1	M04#1	M03#1	M02#1	M01#1	M00#1
F011	M15#1	M14#1	M13#1	M12#1	M11#1	M10#1	M09#1	M08#1
F012	M23#1	M22#1	M21#1	M20#1	M19#1	M18#1	M17#1	M16#1
F013	M31#1	M30#1	M29#1	M28#1	M27#1	M26#1	M25#1	M24#1
F014	M207#1	M206#1	M205#1	M204#1	M203#1	M202#1	M201#1	M200#1
F015	M215#1	M214#1	M213#1	M212#1	M211#1	M210#1	M209#1	M208#1
F016	M307#1	M306#1	M305#1	M304#1	M303#1	M302#1	M301#1	M300#1
F017	M315#1	M314#1	M313#1	M312#1	M311#1	M310#1	M309#1	M308#1
F018								
F019								
F020								
F021								
F022	S07#1	S06#1	S05#1	S04#1	S03#1	S02#1	S01#1	S00#1
F023	S15#1	S14#1	S13#1	S12#1	S11#1	S10#1	S09#1	S08#1
F024	S23#1	S22#1	S21#1	S20#1	S19#1	S18#1	S17#1	S16#1

	7	6	5	4	3	2	1	0
F025	S31#1	S30#1	S29#1	S28#1	S27#1	S26#1	S25#1	S24#1
F026	T07#1	T06#1	T05#1	T04#1	T03#1	T02#1	T01#1	T00#1
F027	T15#1	T14#1	T13#1	T12#1	T11#1	T10#1	T09#1	T08#1
F028	T23#1	T22#1	T21#1	T20#1	T19#1	T18#1	T17#1	T16#1
F029	T31#1	T30#1	T29#1	T28#1	T27#1	T26#1	T25#1	T24#1
F030	B07#1	B06#1	B05#1	B04#1	B03#1	B02#1	B01#1	B00#1
F031	B15#1	B14#1	B13#1	B12#1	B11#1	B10#1	B09#1	B08#1
F032	B23#1	B22#1	B21#1	B20#1	B19#1	B18#1	B17#1	B16#1
F033	B31#1	B30#1	B29#1	B28#1	B27#1	B26#1	B25#1	B24#1
F034	SRSDY#1	SRSP1R#1	SRSP2R#1	SRSP3R#1	SRSP4R#1	GR3O#1	GR2O#1	GR1O#1
F035								SPAL#1
F036	R08O#1	R07O#1	R06O#1	R05O#1	R04O#1	R03O#1	R02O#1	R01O#1
F037					R12O#1	R11O#1	R10O#1	R09O#1
F038					ENB3#1	ENB2#1	SUCLP#1	SCLP#1
F039					CHPCYL#1	CHPMD#1	ENB4#1	
F040	AR7#1	AR6#1	AR5#1	AR4#1	AR3#1	AR2#1	AR1#1	AR0#1
F041	AR15#1	AR14#1	AR13#1	AR12#1	AR11#1	AR10#1	AR09#1	AR08#1
F042								
F043								
F044				SYCAL SYCAL #1	FSPPH FSPPH #1	FSPSY FSPSY #1	FSCSL#1	
F045	ORARA#1	TLMA#1	LDT2A#1	LDT1A#1	SARA#1	SDTA#1	SSTA#1	ALMA#1
F046	MORA2A#1	MORA1A#1	PORA2A#1	SLVSA#1	RCFNA#1	RCHPA#1	CFINA#1	CHPA#1
F047				EXOFA#1	SORENA#1	MSOVRA#1	INCSTA#1	PC1DTA#1
F048								
F049	ORARB#1	TLMB#1	LDT2B#1	LDT1B#1	SARB#1	SDTB#1	SSTB#1	ALMB#1

	7	6	5	4	3	2	1	0
F050	MORA2B#1	MORA1B#1	PORA2B#1	SLVSB#1	RCFNB#1	RCHPB#1	CFINB#1	CHPB#1
F051				EXOFB#1	SORENB#1	MSOVRB#1	INCSTB#1	PC1DTB#1
F052								
F053	EKENB			BGEACT#1	RPALM#1	RPBSY#1	PRGDPL	INHKY
F054	UO007#1	UO006#1	UO005#1	UO004#1	UO003#1	UO002#1	UO001#1	UO000#1
F055	UO015#1	UO014#1	UO013#1	UO012#1	UO011#1	UO010#1	UO009#1	UO008#1
F056	UO107#1	UO106#1	UO105#1	UO104#1	UO103#1	UO102#1	UO101#1	UO100#1
F057	UO115#1	UO114#1	UO113#1	UO112#1	UO111#1	UO110#1	UO109#1	UO108#1
F058	UO123#1	UO122#1	UO121#1	UO120#1	UO119#1	UO118#1	UO117#1	UO116#1
F059	UO131#1	UO130#1	UO129#1	UO128#1	UO127#1	UO126#1	UO125#1	UO124#1
F060						ESCAN#1	ESEND#1	EREND#1
F061							BCLP#1	BUCLP#1
F062	PRTSF#1			S2MES#1	S1MES#1			
F063	PSYN#1	WATO#1				PSAR#1	PSE2#1	PSE1#1
F064	TIALM	TICLK	COSP			TLCHI#1	TLNW#1	TLCH#1
F065	HOBSYN#1	SYNMOD#1	MSPCF#1	RTRCTF#1			RGSPM#1	RGSP#1
F066			PECK2#1				RTPT#1	G08MD#1
F067								
F068								
F069								
F070	PSW08#1	PSW07#1	PSW06#1	PSW05#1	PSW04#1	PSW03#1	PSW02#1	PSW01#1
F071	PSW16#1	PSW15#1	PSW14#1	PSW13#1	PSW12#1	PSW11#1	PSW10#1	PSW09#1
F072	OUT7#1	OUT6#1	OUT5#1	OUT4#1	OUT3#1	OUT2#1	OUT1#1	OUT0#1
F073				ZRNO#1		MD4O#1	MD2O#1	MD1O#1
F074								

	7	6	5	4	3	2	1	0
F075	SPO#1	KEYO#1	DRNO#1	MLKO#1	SBKO#1	BDTO#1		
F076			ROV2O#1	ROV1O#1	RTAP#1		MP2O#1	MP1O#1
F077		RTO#1			HS1DO#1	HS1CO#1	HS1BO#1	HS1AO#1
F078	*FV7O#1	*FV6O#1	*FV5O#1	*FV4O#1	*FV3O#1	*FV2O#1	*FV1O#1	*FV0O#1
F079	*JV7O#1	*JV6O#1	*JV5O#1	*JV4O#1	*JV3O#1	*JV2O#1	*JV1O#1	*JV0O#1
F080	*FV15O#1	*FV14O#1	*FV13O#1	*FV12O#1	*FV11O#1	*FV10O#1	*FV9O#1	*FV8O#1
F081	-J4O#1	+J4O#1	-J3O#1	+J3O#1	-J2O#1	+J2O#1	-J1O#1	+J1O#1
F082						RVSL#1		
F083								
F084								
F085								
F086								
F087								
F088								
F089								
F090						ABTSP2#1	ABTSP1#1	ABTQSV#1
F091								
F092			TRSPS#1		TRACT#1			
F093	SVWRN4#1	SVWRN3#1	SVWRN2#1	SVWRN1#1				LIFOVR#1
F094	ZP8#1	ZP7#1	ZP6#1	ZP5#1	ZP4#1	ZP3#1	ZP2#1	ZP1#1
F095								
F096	ZP28#1	ZP27#1	ZP26#1	ZP25#1	ZP24#1	ZP23#1	ZP22#1	ZP21#1
F097								
F098	ZP38#1	ZP37#1	ZP36#1	ZP35#1	ZP34#1	ZP33#1	ZP32#1	ZP31#1
F099								

	7	6	5	4	3	2	1	0
F100	ZP48#1	ZP47#1	ZP46#1	ZP45#1	ZP44#1	ZP43#1	ZP42#1	ZP41#1
F101								
F102	MV8#1	MV7#1	MV6#1	MV5#1	MV4#1	MV3#1	MV2#1	MV1#1
F103								
F104	INP8#1	INP7#1	INP6#1	INP5#1	INP4#1	INP3#1	INP2#1	INP1#1
F105								
F106	MVD8#1	MVD7#1	MVD6#1	MVD5#1	MVD4#1	MVD3#1	MVD2#1	MVD1#1
F107								
F108	MMI8#1	MMI7#1	MMI6#1	MMI5#1	MMI4#1	MMI3#1	MMI2#1	MMI1#1
F109								
F110	MDTCH8#1	MDTCH7#1	MDTCH6#1	MDTCH5#1	MDTCH4#1	MDTCH3#1	MDTCH2#1	MDTCH1#1
F111								
F112	EADEN8#1	EADEN7#1	EADEN6#1	EADEN5#1	EADEN4#1	EADEN3#1	EADEN2#1	EADEN1#1
F113								
F114	TRQL8#1	TRQL7#1	TRQL6#1	TRQL5#1	TRQL4#1	TRQL3#1	TRQL2#1	TRQL1#1
F115								
F116	FRP8#1	FRP7#1	FRP6#1	FRP5#1	FRP4#1	FRP3#1	FRP2#1	FRP1#1
F117								
F118	SYN8O#1	SYN7O#1	SYN6O#1	SYN5O#1	SYN4O#1	SYN3O#1	SYN2O#1	SYN1O#1
F119								
F120	ZRF8#1	ZRF7#1	ZRF6#1	ZRF5#1	ZRF4#1	ZRF3#1	ZRF2#1	ZRF1#1
F121								
F122	HDO7#1	HDO6#1	HDO5#1	HDO4#1	HDO3#1	HDO2#1	HDO1#1	HDO0#1
F123								
F124	+OT8#1	+OT7#1	+OT6#1	+OT5#1	+OT4#1	+OT3#1	+OT2#1	+OT1#1

	7	6	5	4	3	2	1	0
F125								
F126	-OT8#1	-OT7#1	-OT6#1	-OT5#1	-OT4#1	-OT3#1	-OT2#1	-OT4#1
F127								
F128								
F129	*EAXSL#1		EOV0#1					
F130	EBSYA#1	EOTNA#1	EOTPA#1	EGENA#1	EDENA#1	EIALA#1	ECKZA#1	EINPA#1
F131							EABUFA#1	EMFA#1
F132	EM28A#1	EM24A#1	EM22A#1	EM21A#1	EM18A#1	EM14A#1	EM12A#1	EM11A#1
F133	EBSYB#1	EOTNB#1	EOTPB#1	EGENB#1	EDENB#1	EIALB#1	ECKZB#1	EINPB#1
F134							EABUFB#1	EMFB#1
F135	EM28B#1	EM24B#1	EM22B#1	EM21B#1	EM18B#1	EM14B#1	EM12B#1	EM11B#1
F136	EBSYC#1	EOTNC#1	EOTPC#1	EGENC#1	EDENC#1	EIALC#1	ECKZC#1	EINPC#1
F137							EABUFC#1	EMFC#1
F138	EM28C#1	EM24C#1	EM22C#1	EM21C#1	EM18C#1	EM14C#1	EM12C#1	EM11C#1
F139	EBSYD#1	EOTND#1	EOTPD#1	EGEND#1	EDEND#1	EIALD#1	ECKZD#1	EINPD#1
F140							EABUFD#1	EMFD#1
F141	EM28D#1	EM24D#1	EM22D#1	EM21D#1	EM18D#1	EM14D#1	EM12D#1	EM11D#1
F142	EM48A#1	EM44A#1	EM42A#1	EM41A#1	EM38A#1	EM34A#1	EM32A#1	EM31A#1
F143								
F144								
F145	EM48B#1	EM44B#1	EM42B#1	EM41B#1	EM38B#1	EM34B#1	EM32B#1	EM31B#1
F146								
F147								
F148	EM48C#1	EM44C#1	EM42C#1	EM41C#1	EM38C#1	EM34C#1	EM32C#1	EM31C#1
F149								

	7	6	5	4	3	2	1	0
F150								
F151	EM48D#1	EM44D#1	EM42D#1	EM41D#1	EM38D#1	EM34D#1	EM32D#1	EM31D#1
F152								
F153								
F154								
F155								
F156								
F157								
F158								
F159								
F160								
F161								
F162								
F163								
F164								
F165								
F166								
F167								
F168	ORARC#1	TLMC#1	LDT2C#1	LDT1C#1	SARC#1	SDTC#1	SSTC#1	ALMC#1
F169	MORA2C#1	MORA1C#1	PORA2C#1	SLVSC#1	RCFNC#1	RCHPC#1	CFINC#1	CHPC#1
F170				EXOFC#1	SORENC#1	MSOVRC#1	INCSTC#1	PC1DTC#1
F171								
F172	PBATL#1	PBATZ#1						
F173								
F174								

	7	6	5	4	3	2	1	0
F175								
F176								
F177	EDGN#1	EPARM#1	EVAR#1	EPRG#1	EWIO#1	ESTPIO#1	ERDIO#1	IOLNK#1
F178					SRLNO3#1	SRLNO2#1	SRLNO1#1	SRLNO0#1
F179								
F180	CLRCH8#1	CLRCH7#1	CLRCH6#1	CLRCH5#1	CLRCH4#1	CLRCH3#1	CLRCH2#1	CLRCH1#1
F181								
F182	EACNT8#1	EACNT7#1	EACNT6#1	EACNT5#1	EACNT4#1	EACNT3#1	EACNT2#1	EACNT1#1
F183								
F184								
F185								
F186								
F187								
F188								
F189								
F190								
F191								
F192								
F193								
F194								
F195								
F196								
F197								
F198								
F199								

	7	6	5	4	3	2	1	0
F200								
F201								
F202								
F203								
F204								
F205								
F206								
F207								
F208								
F209								
F210								
F211								
F212								
F213								
F214								
F215								
F216								
F217								
F218								
F219								
F220								
F221								
F222								
F223								
F224								

	7	6	5	4	3	2	1	0
F225								
F226								
F227								
F228								
F229								
F230								
F231								
F232								
F233								
F234								
F235								
F236								
F237								
F238								
F239								
F240								
F241								
F242								
F243								
F244								
F245								
F246								
F247								
F248								
F249								

	7	6	5	4	3	2	1	0
F250								
F251								
F252								
F253								
F254								
F255								
F256								
F257								
F258								
F259								
F260								
F261								
F262								
F263								
F264	SPWRN8#1	SPWRN7#1	SPWRN6#1	SPWRN5#1	SPWRN4#1	SPWRN3#1	SPWRN2#1	SPWRN1#1
F265								SPWRN9#1
F266	ORARD#1	TLMD#1	LDT2D#1	LDT1D#1	SARD#1	SDTD#1	SSTD#1	ALMD#1
F267	MORA2D#1	MORA1D#1	PORA2D#1	SLVSD#1	RCFND#1	RCHPD#1	CFIND#1	CHPD#1
F268				EXOFD#1	SOREND#1	MSOVRD#1	INCSTD#1	PC1DTD#1
F269								
F270								
F271								
F272								
F273								
F274								

	7	6	5	4	3	2	1	0
F275								
F276	UO023 #1	UO022 #1	UO021 #1	UO020 #1	UO019 #1	UO018 #1	UO017 #1	UO016 #1
F277	UO031 #1	UO030 #1	UO029 #1	UO028 #1	UO027 #1	UO026 #1	UO025 #1	UO024 #1
F278								
F279								
F280	UO207 #1	UO206 #1	UO205 #1	UO204 #1	UO203 #1	UO202 #1	UO201 #1	UO200 #1
F281	UO215 #1	UO214 #1	UO213 #1	UO212 #1	UO211 #1	UO210 #1	UO209 #1	UO208 #1
F282	UO223 #1	UO222 #1	UO221 #1	UO220 #1	UO219 #1	UO218 #1	UO217 #1	UO216 #1
F283	UO231 #1	UO230 #1	UO229 #1	UO228 #1	UO227 #1	UO226 #1	UO225 #1	UO224 #1
F284	UO307 #1	UO306 #1	UO305 #1	UO304 #1	UO303 #1	UO302 #1	UO301 #1	UO300 #1
F285	UO315 #1	UO314 #1	UO313 #1	UO312 #1	UO311 #1	UO310 #1	UO309 #1	UO308 #1
F286	UO323 #1	UO322 #1	UO321 #1	UO320 #1	UO319 #1	UO318 #1	UO317 #1	UO316 #1
F287	UO331 #1	UO330 #1	UO329 #1	UO328 #1	UO327 #1	UO326 #1	UO325 #1	UO324 #1
F288								
F289								
F290								
F291								
F292								
F293								
F294								
F295								
F296								
F297								
F298	TDF9 #1	TDF7 #1	TDF6 #1	TDF5 #1	TDF4 #1	TDF3 #1	TDF2 #1	TDF1 #1
F299								

	7	6	5	4	3	2	1	0
F300								
F301								
F302								
F303								
F304								
F305								
F306								
F307								
F308								
F309								
F310								
F311								
F312								
F313								
F314								
F315								

CNC Path 2→PMC

Address	Bit number							
	7	6	5	4	3	2	1	0
F1000	OP#2	SA#2	STL#2	SPL#2				RWD#2
F1001	MA#2		TAP#2	ENB#2	DEN#2	BAL#2	RST#2	AL#2
F1002	MDRN#2	CUT#2		SRNMV#2	THRD#2	CSS#2	RPDO#2	INCH#2
F1003	MTCHIN#2	MEDT#2	MMEM#2	MRMT#2	MMDI#2	MJ#2	MH#2	MINC#2
F1004			MREF#2	MAFL#2	MSBK#2	MABSM#1	MMLK#2	MBDT1#2
F1005	MBDT9#2	MBDT8#2	MBDT7#2	MBDT6#2	MBDT5#2	MBDT4#2	MBDT3#2	MBDT2#2
F1006								
F1007	BF#2			BF#2	TF#2	SF#2	EFD#2	MF#2
F1008			MF3#2	MF2#2				EF#2
F1009	DM00#2	DM01#2	DM02#2	DM30#2				
F010	M07#2	M06#2	M05#2	M04#2	M03#2	M02#2	M01#2	M00#2
F1011	M15#2	M14#2	M13#2	M12#2	M11#2	M10#2	M09#2	M08#2
F1012	M23#2	M22#2	M21#2	M20#2	M19#2	M18#2	M17#2	M16#2
F1013	M31#2	M30#2	M29#2	M28#2	M27#2	M26#2	M25#2	M24#2
F1014	M207#2	M206#2	M205#2	M204#2	M203#2	M202#2	M201#2	M200#2
F1015	M215#2	M214#2	M213#2	M212#2	M211#2	M210#2	M209#2	M208#2
F1016	M307#2	M306#2	M305#2	M304#2	M303#2	M302#2	M301#2	M300#2
F1017	M315#2	M314#2	M313#2	M312#2	M311#2	M310#2	M309#2	M308#2
F1018								
F1019								
F1020								
F1021								
F1022	S07#2	S06#2	S05#2	S04#2	S03#2	S02#2	S01#2	S00#2
F1023	S15#2	S14#2	S13#2	S12#2	S11#2	S10#2	S09#2	S08#2
F1024	S23#2	S22#2	S21#2	S20#2	S19#2	S18#2	S17#2	S16#2

	7	6	5	4	3	2	1	0
F1025	S31#2	S30#2	S29#2	S28#2	S27#2	S26#2	S25#2	S24#2
F1026	T07#2	T06#2	T05#2	T04#2	T03#2	T02#2	T01#2	T00#2
F1027	T15#2	T14#2	T13#2	T12#2	T11#2	T10#2	T09#2	T08#2
F1028	T23#2	T22#2	T21#2	T20#2	T19#2	T18#2	T17#2	T16#2
F1029	T31#2	T30#2	T29#2	T28#2	T27#2	T26#2	T25#2	T24#2
F1030	B07#2	B06#2	B05#2	B04#2	B03#2	B02#2	B01#2	B00#2
F1031	B15#2	B14#2	B13#2	B12#2	B11#2	B10#2	B09#2	B08#2
F1032	B23#2	B22#2	B21#2	B20#2	B19#2	B18#2	B17#2	B16#2
F1033	B31#2	B30#2	B29#2	B28#2	B27#2	B26#2	B25#2	B24#2
F1034	SRSDY#2	SRSP1R#2	SRSP2R#2	SRSP3R#2	SRSP4R#2	GR3O#2	GR2O#2	GR1O#2
F1035								SPAL#2
F1036	R08O#2	R07O#2	R06O#2	R05O#2	R04O#2	R03O#2	R02O#2	R01O#2
F1037					R12O#2	R11O#2	R10O#2	R09O#2
F1038					ENB3#2	ENB2#2	SUCLP#2	SCLP#2
F1039					CHPCYL#2	CHPMD#2	ENB4#2	
F1040	AR7#2	AR6#2	AR5#2	AR4#2	AR3#2	AR2#2	AR1#2	AR0#2
F1041	AR15#2	AR14#2	AR13#2	AR12#2	AR11#2	AR10#2	AR09#2	AR08#2
F1042								
F1043								
F1044					FSPPH#2	FSPSY#2	FSCSL#2	
F1045	ORARA#2	TLMA#2	LDT2A#2	LDT1A#2	SARA#2	SDTA#2	SSTA#2	ALMA#2
F1046	MORA2A#2	MORA1A#2	PORA2A#2	SLVSA#2	RCFNA#2	RCHPA#2	CFINA#2	CHPA#2
F1047				EXOFA#2	SORENA#2	MSOVRA#2	INCSTA#2	PC1DTA#2
F1048								
F1049	ORARB#2	TLMB#2	LDT2B#2	LDT1B#2	SARB#2	SDTB#2	SSTB#2	ALMB#2

	7	6	5	4	3	2	1	0
F1050	MORA2B #2	MORA1B #2	PORA2B #2	SLVSB #2	RCFNB #2	RCHPB #2	CFINB #2	CHPB #2
F1051				EXOFB #2	SORENB #2	MSOVRB #2	INCSTB #2	PC1DTB #2
F1052								
F1053				BGEACT #2	RPALM #2	RPBSY #2		
F1054	UO007 #2	UO006 #2	UO005 #2	UO004 #2	UO003 #2	UO002 #2	UO001 #2	UO000 #2
F1055	UO015 #2	UO014 #2	UO013 #2	UO012 #2	UO011 #2	UO010 #2	UO009 #2	UO008 #2
F1056	UO107 #2	UO106 #2	UO105 #2	UO104 #2	UO103 #2	UO102 #2	UO101 #2	UO100 #2
F1057	UO115 #2	UO114 #2	UO113 #2	UO112 #2	UO111 #2	UO110 #2	UO109 #2	UO108 #2
F1058	UO123 #2	UO122 #2	UO121 #2	UO120 #2	UO119 #2	UO118 #2	UO117 #2	UO116 #2
F1059	UO131 #2	UO130 #2	UO129 #2	UO128 #2	UO127 #2	UO126 #2	UO125 #2	UO124 #2
F1060						ESCAN #2	ESEND #2	EREND #2
F1061							BCLP #2	BUCLP #2
F1062	PRTSF #2			S2MES #2	S1MES #2			
F1063	PSYN #2	WATO #2				PSAR #2	PSE2 #2	PSE1 #2
F1064						TLCHI #2	TLNW #2	TLCH #2
F1065	HOBYSYN #2	SYNMOD #2	MSPCF #2	RTRCTF #2			RGSPM #2	RGSP #2
F1066			PECK2 #2				RTPT #2	G08MD #2
F1067								
F1068								
F1069								
F1070	PSW08 #2	PSW07 #2	PSW06 #2	PSW05 #2	PSW04 #2	PSW03 #2	PSW02 #2	PSW01 #2
F1071	PSW16 #2	PSW15 #2	PSW14 #2	PSW13 #2	PSW12 #2	PSW11 #2	PSW10 #2	PSW09 #2
F1072	OUT7 #2	OUT6 #2	OUT5 #2	OUT4 #2	OUT3 #2	OUT2 #2	OUT1 #2	OUT0 #2
F1073				ZRNO #2		MD4O #2	MD2O #2	MD1O #2
F1074								

	7	6	5	4	3	2	1	0
F1075	SPO#2	KEYO#2	DRNO#2	MLKO#2	SBKO#2	BDTO#2		
F1076			ROV2O#2	ROV1O#2	RTAP#2		MP2O#2	MP1O#2
F1077		RTO#2			HS1DO#2	HS1CO#2	HS1BO#2	HS1AO#2
F1078	*FV7O#2	*FV6O#2	*FV5O#2	*FV4O#2	*FV3O#2	*FV2O#2	*FV1O#2	*FV0O#2
F1079	*JV7O#2	*JV6O#2	*JV5O#2	*JV4O#2	*JV3O#2	*JV2O#2	*JV1O#2	*JV0O#2
F1080	*FV15O#2	*FV14O#2	*FV13O#2	*FV12O#2	*FV11O#2	*FV10O#2	*FV09O#2	*FV08O#2
F1081	-J4O#2	+J4O#2	-J3O#2	+J3O#2	-J2O#2	+J2O#2	-J1O#2	+J1O#2
F1082						RVSL#2		
F1083								
F1084								
F1085								
F1086								
F1087								
F1088								
F1089								
F1090						ABTSP2#2	ABTSP1#2	ABTQSV#2
F1091								
F1092			TRSPS#2		TRACT#2			
F1093	SVWRN4#2	SVWRN3#2	SVWRN2#2	SVWRN1#2				LIFOVR#2
F1094	ZP8#2	ZP7#2	ZP6#2	ZP5#2	ZP4#2	ZP3#2	ZP2#2	ZP1#2
F1095								
F1096	ZP28#2	ZP27#2	ZP26#2	ZP25#2	ZP24#2	ZP23#2	ZP22#2	ZP21#2
F1097								
F1098	ZP38#2	ZP37#2	ZP36#2	ZP35#2	ZP34#2	ZP33#2	ZP32#2	ZP31#2
F1099								

	7	6	5	4	3	2	1	0
F1100	ZP48#2	ZP47#2	ZP46#2	ZP45#2	ZP44#2	ZP43#2	ZP42#2	ZP41#2
F1101								
F1102	MV8#2	MV7#2	MV6#2	MV5#2	MV4#2	MV3#2	MV2#2	MV1#2
F1103								
F1104	INP8#2	INP7#2	INP6#2	INP5#2	INP4#2	INP3#2	INP2#2	INP1#2
F1105								
F1106	MVD8#2	MVD7#2	MVD6#2	MVD5#2	MVD4#2	MVD3#2	MVD2#2	MVD1#2
F1107								
F1108	MMI8#2	MMI7#2	MMI6#2	MMI5#2	MMI4#2	MMI3#2	MMI2#2	MMI1#2
F1109								
F1110	MDTCH8#2	MDTCH7#2	MDTCH6#2	MDTCH5#2	MDTCH4#2	MDTCH3#2	MDTCH2#2	MDTCH1#2
F1111								
F1112	EADEN8#2	EADEN7#2	EADEN6#2	EADEN5#2	EADEN4#2	EADEN3#2	EADEN2#2	EADEN1#2
F1113								
F1114	TRQL8#2	TRQL7#2	TRQL6#2	TRQL5#2	TRQL4#2	TRQL3#2	TRQL2#2	TRQL1#2
F1115								
F1116	FRP8#2	FRP7#2	FRP6#2	FRP5#2	FRP4#2	FRP3#2	FRP2#2	FRP1#2
F1117								
F1118	SYN8O#2	SYN7O#2	SYN6O#2	SYN5O#2	SYN4O#2	SYN3O#2	SYN2O#2	SYN1O#2
F1119								
F1120	ZRF8#2	ZRF7#2	ZRF6#2	ZRF5#2	ZRF4#2	ZRF3#2	ZRF2#2	ZRF1#2
F1121								
F1122	HDO7#2	HDO6#2	HDO5#2	HDO4#2	HDO3#2	HDO2#2	HDO1#2	HDO0#2
F1123								
F1124	+OT8#2	+OT7#2	+OT6#2	+OT5#2	+OT4#2	+OT3#2	+OT2#2	+OT1#2

	7	6	5	4	3	2	1	0
F1125								
F1126	-OT8#2	-OT7#2	-OT6#2	-OT5#2	-OT4#2	-OT3#2	-OT2#2	-OT1#2
F1127								
F1128								
F1129	*EAXSL#2		EOV0#2					
F1130	EBSYA#2	EOTNA#2	EOTP#2	EGENA#2	EDENA#2	EIALA#2	ECKZA#2	EINPA#2
F1131							EABUFA#2	EMFA#2
F1132	EM28A#2	EM24A#2	EM22A#2	EM21A#2	EM18A#2	EM14A#2	EM12A#2	EM11A#2
F1133	EBSYB#2	EOTNB#2	EOTB#2	EGENB#2	EDENB#2	EIALB#2	ECKZB#2	EINPB#2
F1134							EABUFB#2	EMFB#2
F1135	EM28B#2	EM24B#2	EM22B#2	EM21B#2	EM18B#2	EM14B#2	EM12B#2	EM11B#2
F1136	EBSYC#2	EOTNC#2	EOTC#2	EGENC#2	EDENC#2	EIALC#2	ECKZC#2	EINPC#2
F1137							EABUFC#2	EMFC#2
F1138	EM28C#2	EM24C#2	EM22C#2	EM21C#2	EM18C#2	EM14C#2	EM12C#2	EM11C#2
F1139	EBSYD#2	EOTND#2	EOTD#2	EGEND#2	EDEND#2	EIALD#2	ECKZD#2	EINPD#2
F1140							EABUFD#2	EMFD#2
F1141	EM28D#2	EM24D#2	EM22D#2	EM21D#2	EM18D#2	EM14D#2	EM12D#2	EM11D#2
F1142	EM48A#2	EM44A#2	EM42A#2	EM41A#2	EM38A#2	EM34A#2	EM32A#2	EM31A#2
F1143								
F1144								
F1145	EM48B#2	EM44B#2	EM42B#2	EM41B#2	EM38B#2	EM34B#2	EM32B#2	EM31B#2
F1146								
F1147								
F1148	EM48C#2	EM44C#2	EM42C#2	EM41C#2	EM38C#2	EM34C#2	EM32C#2	EM31C#2
F1149								

	7	6	5	4	3	2	1	0
F1150								
F1151	EM48D #2	EM44D #2	EM42D #2	EM41D #2	EM38D #2	EM34D #2	EM32D #2	EM31D #2
F1152								
F1153								
F1154								
F1155								
F1156								
F1157								
F1158								
F1159								
F1160								
F1161								
F1162								
F1163								
F1164								
F1165								
F1166								
F1167								
F1168	ORARC #2	TLMC #2	LDT2C #2	LDT1C #2	SARC #2	SDTC #2	SSTC #2	ALMC #2
F1169	MORA2C #2	MORA1C #2	PORA2C #2	SLVSC #2	RCFNC #2	RCHPC #2	CFINC #2	CHPC #2
F1170				EXOFC #2	SORENC #2	MSOVR #2	INCSTC #2	PC1DTC #2
F1171								
F1172	PBATL #2	PBATZ #2						
F1173								
F1174								

	7	6	5	4	3	2	1	0
F1175								
F1176								
F1177	EDGN# ²	EPARM# ²	EVAR# ²	EPRG# ²	EWIO# ²	ESTPIO# ²	ERDIO# ²	IOLNK# ²
F1178					SRLNO3# ²	SRLNO2# ²	SRLNO1# ²	SRLNO0# ²
F1179								
F1180	CLRCH8# ²	CLRCH7# ²	CLRCH6# ²	CLRCH5# ²	CLRCH4# ²	CLRCH3# ²	CLRCH2# ²	CLRCH1# ²
F1181								
F1182	EACNT8# ²	EACNT7# ²	EACNT6# ²	EACNT5# ²	EACNT4# ²	EACNT3# ²	EACNT2# ²	EACNT1# ²
F1183								
F1184								
F1185								
F1186								
F1187								
F1188								
F1189								
F1190								
F1191								
F1192								
F1193								
F1194								
F1195								
F1196								
F1197								
F1198								
F1199								

	7	6	5	4	3	2	1	0
F1200								
F1201								
F1202								
F1203								
F1204								
F1205								
F1206								
F1207								
F1208								
F1209								
F1210								
F1211								
F1212								
F1213								
F1214								
F1215								
F1216								
F1217								
F1218								
F1219								
F1220								
F1221								
F1222								
F1223								
F1224								

	7	6	5	4	3	2	1	0
F1225								
F1226								
F1227								
F1228								
F1229								
F1230								
F1231								
F1232								
F1233								
F1234								
F1235								
F1236								
F1237								
F1238								
F1239								
F1240								
F1241								
F1242								
F1243								
F1244								
F1245								
F1246								
F1247								
F1248								
F1249								

	7	6	5	4	3	2	1	0
F1250								
F1251								
F1252								
F1253								
F1254								
F1255								
F1256								
F1257								
F1258								
F1259								
F1260								
F1261								
F1262								
F1263								
F1264	SPWRN8#2	SPWRN7#2	SPWRN6#2	SPWRN5#2	SPWRN4#2	SPWRN3#2	SPWRN2#2	SPWRN1#2
F1265								SPWRN9#2
F1266	ORARD#2	TLMD#2	LDT2D#2	LDT1D#2	SARD#2	SDTD#2	SSTD#2	ALMD#2
F1267	MORA2D#2	MORA1D#2	PORA2D#2	SLVSD#2	RCFND#2	RCHPD#2	CFIND#2	CHPD#2
F1268				EXOFD#2	SOREND#2	MSOVRD#2	INCSTD#2	PC1DTD#2
F1269								
F1270								
F1271								
F1272								
F1273								
F1274								

	7	6	5	4	3	2	1	0
F1275								
F1276	UO023#2	UO022#2	UO021#2	UO020#2	UO019#2	UO018#2	UO017#2	UO016#2
F1277	UO031#2	UO030#2	UO029#2	UO028#2	UO027#2	UO026#2	UO025#2	UO024#2
F1278								
F1279								
F1280	UO207#2	UO206#2	UO205#2	UO204#2	UO203#2	UO202#2	UO201#2	UO200#2
F1281	UO215#2	UO214#2	UO213#2	UO212#2	UO211#2	UO210#2	UO209#2	UO208#2
F1282	UO223#2	UO222#2	UO221#2	UO220#2	UO219#2	UO218#2	UO217#2	UO216#2
F1283	UO231#2	UO230#2	UO229#2	UO228#2	UO227#2	UO226#2	UO225#2	UO224#2
F1284	UO307#2	UO306#2	UO305#2	UO304#2	UO303#2	UO302#2	UO301#2	UO300#2
F1285	UO315#2	UO314#2	UO313#2	UO312#2	UO311#2	UO310#2	UO309#2	UO308#2
F1286	UO323#2	UO322#2	UO321#2	UO320#2	UO319#2	UO318#2	UO317#2	UO316#2
F1287	UO331#2	UO330#2	UO329#2	UO328#2	UO327#2	UO326#2	UO325#2	UO324#2
F1288								
F1289								
F1290								
F1291								
F1292								
F1293								
F1294								
F1295								
F1296								
F1297								
F1298	TDF8#2	TDF7#2	TDF6#2	TDF5#2	TDF4#2	TDF3#2	TDF2#2	TDF1#2
F1299								

	7	6	5	4	3	2	1	0
F1300								
F1301								
F1302								
F1303								
F1304								
F1305								
F1306								
F1307								
F1308								
F1309								
F1310								
F1311								
F1312								
F1313								
F1314								
F1315								

**A.1.3
Series 21i/210i/210is
Address List**

The figure below illustrates the addresses of interface signals between the CNC and PMC.

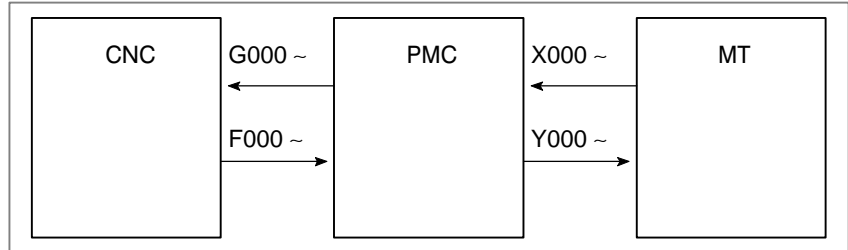

Following shows table of addresses:

In an item where both T series and M series are described, some signals are covered with shade () in the signal address figure as shown below. This means either T series or M series does not have this signal. Upper part is for T series and lower part is for M series.

[Example 1]

Signals EXLM and ST are common signals, STLK is for T series only and RLSOT and RVS are for M series only.

	#7	#6		#2	#1	#0	
G007	RLSOT	EXLM		ST	STLK	RVS	T series M series

**Notes when using the
PMC-SA1**

When the PMC-SA1 is used, transmittable signals are restricted as shown below.

Signal address	Description
G000 to G255	Signals transmitted from the PMC to the CNC when the PMC-SA1 is used
F000 to F255	Signals transmitted from the CNC to the PMC when the PMC-SA1 is used

As seen from the above table, signals at G256 and higher and those at F256 cannot be used in a system having the PMC-SA1. Therefore, features requiring these signals cannot be used.

**Notes when using the
PMC-SB7**

When the PMC-SB7 is used, transmittable signals are restricted as shown below.

Signal address	Description
G000 to G512	Signals transmitted from the PMC to the CNC when the PMC-SB7 is used
F000 to F512	Signals transmitted from the CNC to the PMC when the PMC-SB7 is used

MT → PMC

Address	Bit number								
	7	6	5	4	3	2	1	0	
X000									
X001									
X002									
X003									
X004	SKIP	ESKIP SKIP6	MIT2 SKIP5	MIT2 SKIP4	MIT1 SKIP3	MIT1 SKIP2	ZAE SKIP8	XAE SKIP7	(T series)
	SKIP	ESKIP				ZAE	YAE	XAE	(M series)
X005									
X006									
X007									
X008				*ESP					
X009				*DEC5	*DEC4	*DEC3	*DEC2	*DEC1	
X010									
X011									
X012									

● T series/M series

PMC → CNC

Address	Bit number							
	7	6	5	4	3	2	1	0
G000	ED7	ED6	ED5	ED4	ED3	ED2	ED1	ED0
G001	ED15	ED14	ED13	ED12	ED11	ED10	ED9	ED8
G002	ESTB	EA6	EA5	EA4	EA3	EA2	EA1	EA0
G003								
G004			MFIN3	MFIN2	FIN			
G005	BFIN	AFL		BFIN	TFIN	SFIN	EFIN	MFIN
G006		SKIPP		OVC		*ABSM		SRN
G007	RLSOT	EXLM	*FLWU	RLSOT3		ST	STLK	
G008	ERS	RRW	*SP	*ESP	*BSL		*CSL	*IT
G009				PN16	PN8	PN4	PN2	PN1
G010	*JV7	*JV6	*JV5	*JV4	*JV3	*JV2	*JV1	*JV0
G011	*JV15	*JV14	*JV13	*JV12	*JV11	*JV10	*JV9	*JV8
G012	*FV7	*FV6	*FV5	*FV4	*FV3	*FV2	*FV1	*FV0
G013								
G014							ROV2	ROV1
G015								
G016	F1D							
G017								
G018	HS2D	HS2C	HS2B	HS2A	HS1D	HS1C	HS1B	HS1A
G019	RT		MP2	MP1	HS3D	HS3C	HS3B	HS3A
G020								
G021								
G022								
G023								
G024								

	7	6	5	4	3	2	1	0
G025								
G026								
G027	CON		*SSTP3	*SSTP2	*SSTP1	SWS3	SWS2	SWS1
G028	PC2SLC	SPSTP	*SCPF	*SUCPF		GR2	GR1	
G029		*SSTP	SOR	SAR		GR31		GR21
G030	SOV7	SOV6	SOV5	SOV4	SOV3	SOV2	SOV1	SOV0
G031	PKESS2	PKESS1						
G032	R08I	R07I	R06I	R05I	R04I	R03I	R02I	R01I
G033	SIND	SSIN	SGN		R12I	R11I	R10I	R09I
G034	R08I2	R07I2	R06I2	R05I2	R04I2	R03I2	R02I2	R01I2
G035	SIND2	SSIN2	SGN2		R12I2	R11I2	R10I2	R09I2
G036	R08I3	R07I3	R06I3	R05I3	R04I3	R03I3	R02I3	R01I3
G037	SIND3	SSIN3	SGN3		R12I3	R11I3	R10I3	R09I3
G038	*BECLP	*BEUCP			SPPHS	SPSYC		
G039	GOQSM	WOQSM	OFN5	OFN4	OFN3	OFN2	OFN1	OFN0
G040	WOSET	PRC	S2TLS					
G041	HS2ID	HS2IC	HS2IB	HS2IA	HS1ID	HS1IC	HS1IB	HS1IA
G042	DMMC				HS3ID	HS3IC	HS3IB	HS3IA
G043	ZRN		DNCI			MD4	MD2	MD1
G044							MLK	BDT1
G045	BDT9	BDT8	BDT7	BDT6	BDT5	BDT4	BDT3	BDT2
G046	DRN	KEY4	KEY3	KEY2	KEY1		SBK	KEYPRM
G047	TL128	TL64	TL32	TL16	TL08	TL04	TL02	TL01
G048	TLRST	TLRSTI	TLSKP					TL256
G049	*TLV7	*TLV6	*TLV5	*TLV4	*TLV3	*TLV2	*TLV1	*TLV0

	7	6	5	4	3	2	1	0
G050							*TLV9	*TLV8
G051								
G052	RMTDI7	RMTDI6	RMTDI5	RMTDI4	RMTDI3	RMTDI2	RMTDI1	RMTDI0
G053	CDZ	SMZ			UINT			TMRON
G054	UI007	UI006	UI005	UI004	UI003	UI002	UI001	UI000
G055	UI015	UI014	UI013	UI012	UI011	UI010	UI009	UI008
G056	UI023	UI022	UI021	UI020	UI019	UI018	UI017	UI016
G057	UI031	UI030	UI029	UI028	UI027	UI026	UI025	UI024
G058					EXWT	EXSTP	EXRD	MINP
G059								
G060	*TSB							
G061			RGTS2P	RGTS1P				RGTAP
G062		RTNT					*CRTOF	
G063			NOZAGC					
G064		ESRSYC						
G065								
G066	EKSET						ENBKY	IGNVRY
G067								
G068								
G069								
G070	MRDYA	ORCMA	SFRA	SRVA	CTH1A	CTH2A	TLMHA	TLMLA
G071	RCHA	RSLA	INTGA	SOCNA	MCFNA	SPSLA	*ESPA	ARSTA
G072	RCHHGA	MFNHGA	INCMDA	OVRA	DEFMDA	NRROA	ROTAA	INDXA
G073				DSCNA	SORSLA	MPOFA	SLVA	MORCMA
G074	MRDYB	ORCMB	SFRB	SRVB	CTH1B	CTH2B	TLMHB	TLMLB

	7	6	5	4	3	2	1	0
G075	RCHB	RSLB	INTGB	SOCNB	MCFNB	SPSLB	*ESPB	ARSTB
G076	RCHHGB	MFNHGB	INCMDB	OVRB	DEFMDB	NRROB	ROTAB	INDXB
G077				DSCNB	SORSLB	MPOFB	SLVB	MORCMB
G078	SHA07	SHA06	SHA05	SHA04	SHA03	SHA02	SHA01	SHA00
G079					SHA11	SHA10	SHA09	SHA08
G080	SHB07	SHB06	SHB05	SHB04	SHB03	SHB02	SHB01	SHB00
G081					SHB11	SHB10	SHB09	SHB08
G082	Reserved order-made macro							
G083	Reserved order-made macro							
G084								
G085								
G086								
G087								
G088								
G089								
G090	G2SLC	G2Y	G2Z	G2X		G2RVY	G2RVZ	G2RVX
G091					SRLNI3	SRLNI2	SRLNI1	SRLNI0
G092				BGEN	BGIALM	BGION	IOLS	IOLACK
G093								
G094								
G095								
G096	HROV	*HROV6	*HROV5	*HROV4	*HROV3	*HROV2	*HROV1	*HROV0
G097								
G098	EKC7	EKC6	EKC5	EKC4	EKC3	EKC2	EKC1	EKC0
G099								

	7	6	5	4	3	2	1	0
G100				+J5	+J4	+J3	+J2	+J1
G101								
G102				-J5	-J4	-J3	-J2	-J1
G103								
G104								
G105								
G106				MI5	MI4	MI3	MI2	MI1
G107								
G108				MLK5	MLK4	MLK3	MLK2	MLK1
G109								
G110				+LM5	+LM4	+LM3	+LM2	+LM1
G111								
G112				-LM5	-LM4	-LM3	-LM2	-LM1
G113								
G114				*+L5	*+L4	*+L3	*+L2	*+L1
G115								
G116				*-L5	*-L4	*-L3	*-L2	*-L1
G117								
G118				*+ED5	*+ED4	*+ED3	*+ED2	*+ED1
G119								
G120				*-ED5	*-ED4	*-ED3	*-ED2	*-ED1
G121								
G122	PKESS2	PKESS1						
G123								

	7	6	5	4	3	2	1	0
G124				DTCH5	DTCH4	DTCH3	DTCH2	DTCH1
G125				IUDD5	IUDD4	IUDD3	IUDD2	IUDD1
G126				SVF5	SVF4	SVF3	SVF2	SVF1
G127								
G128								
G129								
G130				*IT5	*IT4	*IT3	*IT2	*IT1
G131								
G132				+MIT5	+MIT4	+MIT3	+MIT2	+MIT1
G133								
G134				-MIT5	-MIT4	-MIT3	-MIT2	-MIT1
G135								
G136				EAX5	EAX4	EAX3	EAX2	EAX1
G137								
G138				SYNC5	SYNC4	SYNC3	SYNC2	SYNC1
G139								
G140				SYNCJ5	SYNCJ4	SYNCJ3	SYNCJ2	SYNCJ1
G141								
G142	EBUFA	ECLRA	ESTPA	ESOFA	ESBKA	EMBUFA	ELCKZA	EFINA
G143	EMSBKA	EC6A	EC5A	EC4A	EC3A	EC2A	EC1A	EC0A
G144	EIF7A	EIF6A	EIF5A	EIF4A	EIF3A	EIF2A	EIF1A	EIF0A
G145	EIF15A	EIF14A	EIF13A	EIF12A	EIF11A	EIF10A	EIF9A	EIF8A
G146	EID7A	EID6A	EID5A	EID4A	EID3A	EID2A	EID1A	EID0A
G147	EID15A	EID14A	EID13A	EID12A	EID11A	EID10A	EID9A	EID8A
G148	EID23A	EID22A	EID21A	EID20A	EID19A	EID18A	EID17A	EID16A

	7	6	5	4	3	2	1	0
G149	EID31A	EID30A	EID29A	EID28A	EID27A	EID26A	EID25A	EID24A
G150	DRNE	RTE	OVCE				ROV2E	ROV1E
G151	*FV7E	*FV6E	*FV5E	*FV4E	*FV3E	*FV2E	*FV1E	*FV0E
G152								
G153								
G154	EBUFB	ECLRB	ESTPB	ESOFB	ESBKB	EMBUFB	ELCKZB	EFINB
G155	EMSBKB	EC6B	EC5B	EC4B	EC3B	EC2B	EC1B	EC0B
G156	EIF7B	EIF6B	EIF5B	EIF4B	EIF3B	EIF2B	EIF1B	EIF0B
G157	EIF15B	EIF14B	EIF13B	EIF12B	EIF11B	EIF10B	EIF9B	EIF8B
G158	EID7B	EID6B	EID5B	EID4B	EID3B	EID2B	EID1B	EID0B
G159	EID15B	EID14B	EID13B	EID12B	EID11B	EID10B	EID9B	EID8B
G160	EID23B	EID22B	EID21B	EID20B	EID19B	EID18B	EID17B	EID16B
G161	EID31B	EID30B	EID29B	EID28B	EID27B	EID26B	EID25B	EID24B
G162								
G163								
G164								
G165								
G166	EBUFC	ECLRC	ESTPC	ESOFC	ESBKC	EMBUFC	ELCKZC	EFINC
G167	EMSBKC	EC6C	EC5C	EC4C	EC3C	EC2C	EC1C	EC0C
G168	EIF7C	EIF6C	EIF5C	EIF4C	EIF3C	EIF2C	EIF1C	EIF0C
G169	EIF15C	EIF14C	EIF13C	EIF12C	EIF11C	EIF10C	EIF9C	EIF8C
G170	EID7C	EID6C	EID5C	EID4C	EID3C	EID2C	EID1C	EID0C
G171	EID15C	EID14C	EID13C	EID12C	EID11C	EID10C	EID9C	EID8C
G172	EID23C	EID22C	EID21C	EID20C	EID19C	EID18C	EID17C	EID16C
G173	EID31C	EID30C	EID29C	EID28C	EID27C	EID26C	EID25C	EID24C

	7	6	5	4	3	2	1	0
G174								
G175								
G176								
G177								
G178	EBUGD	ECLRD	ESTPD	ESOFD	ESBKD	EMBUGD	ELCKZD	EFIND
G179	EMSBKD	EC6D	EC5D	EC4D	EC3D	EC2D	EC1D	EC0D
G180	EIF7D	EIF6D	EIF5D	EIF4D	EIF3D	EIF2D	EIF1D	EIF0D
G181	EIF15D	EIF14D	EIF13D	EIF12D	EIF11D	EIF10D	EIF9D	EIF8D
G182	EID7D	EID6D	EID5D	EID4D	EID3D	EID2D	EID1D	EID0D
G183	EID15D	EID14D	EID13D	EID12D	EID11D	EID10D	EID9D	EID8D
G184	EID23D	EID22D	EID21D	EID20D	EID19D	EID18D	EID17D	EID16D
G185	EID31D	EID30D	EID29D	EID28D	EID27D	EID26D	EID25D	EID24D
G186								
G187								
G188								
G189								
G190								
G191								
G192				IGVRY5	IGVRY4	IGVRY3	IGVRY2	IGVRY1
G193								
G194								
G195								
G196								
G197								
G198				NPOS5	NPOS4	NPOS3	NPOS2	NPOS1

	7	6	5	4	3	2	1	0
G199								
G200				EASIP5	EASIP4	EASIP3	EASIP2	EASIP1
G201			JGRD3	JGRD2	JGRD1			
G202								
G203								
G204								
G205								
G206								
G207								
G208								
G209								
G210								
G211								
G212								
G213								
G214								
G215								
G216								
G217								
G218								
G219								
G220								
G221								
G222								
G223								

	7	6	5	4	3	2	1	0
G224								
G225								
G226								
G227								
G228								
G229								
G230								
G231								
G232								
G233								
G234								
G235								
G236								
G237								
G238								
G239								
G240								
G241								
G242								
G243								
G244								
G245								
G246								
G247								
G248								

	7	6	5	4	3	2	1	0
G249								
G250								
G251								
G252								
G253								
G254								
G255								
G256								
G257								
G258								
G259								
G260								
G261								
G262								
G263								
G264								
G265								
G266								
G267								
G268								
G269								
G270								
G271								
G272								
G273								

	7	6	5	4	3	2	1	0
G274								
G275								
G276	UI107	UI106	UI105	UI104	UI103	UI102	UI101	UI100
G277	UI115	UI114	UI113	UI112	UI111	UI110	UI109	UI108
G278	UI123	UI122	UI121	UI120	UI119	UI118	UI117	UI116
G279	UI131	UI130	UI129	UI128	UI127	UI126	UI125	UI124
G280	UI207	UI206	UI205	UI204	UI203	UI202	UI201	UI200
G281	UI215	UI214	UI213	UI212	UI211	UI210	UI209	UI208
G282	UI223	UI222	UI221	UI220	UI219	UI218	UI217	UI216
G283	UI231	UI230	UI229	UI228	UI227	UI226	UI225	UI224
G284	UI307	UI306	UI305	UI304	UI303	UI302	UI301	UI300
G285	UI315	UI314	UI313	UI312	UI311	UI310	UI309	UI308
G286	UI323	UI322	UI321	UI320	UI319	UI318	UI317	UI316
G287	UI331	UI330	UI329	UI328	UI327	UI326	UI325	UI324
G288								
G289								
G290								
G291								
G292								
G293								
G294								
G295								
G296								
G297								
G298								

	7	6	5	4	3	2	1	0
G299								
G300								
G301								
G302								
G303								
G304								
G305								
G306								
G307								
G308								
G309								
G310								
G311								

CNC → PMC

Address	Bit number							
	7	6	5	4	3	2	1	0
F000	OP	SA	STL	SPL				RWD
F001	MA		TAP	ENB	DEN	BAL	RST	AL
F002	MDRN	CUT		SRNMV	THRD	CSS	RPDO	INCH
F003	MTCHIN	MEDT	MMEM	MRMT	MMDI	MJ	MH	MINC
F004			MREF	MAFL	MSBK	MABSM	MMLK	MBDT1
F005	MBDT9	MBDT8	MBDT7	MBDT6	MBDT5	MBDT4	MBDT3	MBDT2
F006								
F007	BF			BF	TF	SF	EFD	MF
F008			MF3	MF2				EF
F009	DM00	DM01	DM02	DM30				
F010	M07	M06	M05	M04	M03	M02	M01	M00
F011	M15	M14	M13	M12	M11	M10	M09	M08
F012	M23	M22	M21	M20	M19	M18	M17	M16
F013	M31	M30	M29	M28	M27	M26	M25	M24
F014	M207	M206	M205	M204	M203	M202	M201	M200
F015	M215	M214	M213	M212	M211	M210	M209	M208
F016	M307	M306	M305	M304	M303	M302	M301	M300
F017	M315	M314	M313	M312	M311	M310	M309	M308
F018								
F019								
F020								
F021								
F022	S07	S06	S05	S04	S03	S02	S01	S00
F023	S15	S14	S13	S12	S11	S10	S09	S08
F024	S23	S22	S21	S20	S19	S18	S17	S16

	7	6	5	4	3	2	1	0
F025	S31	S30	S29	S28	S27	S26	S25	S24
F026	T07	T06	T05	T04	T03	T02	T01	T00
F027	T15	T14	T13	T12	T11	T10	T09	T08
F028	T23	T22	T21	T20	T19	T18	T17	T16
F029	T31	T30	T29	T28	T27	T26	T25	T24
F030	B07	B06	B05	B04	B03	B02	B01	B00
F031	B15	B14	B13	B12	B11	B10	B09	B08
F032	B23	B22	B21	B20	B19	B18	B17	B16
F033	B31	B30	B29	B28	B27	B26	B25	B24
F034	SRSRDY	SRSP1R	SRSP2R			GR3O	GR2O	GR1O
F035								SPAL
F036	R08O	R07O	R06O	R05O	R04O	R03O	R02O	R01O
F037					R12O	R11O	R10O	R09O
F038					ENB3	ENB2	SUCLP	SCLP
F039								
F040	AR7	AR6	AR5	AR4	AR3	AR2	AR1	AR0
F041	AR15	AR14	AR13	AR12	AR11	AR10	AR09	AR08
F042								
F043								
F044				SYCAL	FSPPH	FSPSY	FSCSL	
F045	ORARA	TLMA	LDT2A	LDT1A	SARA	SDTA	SSTA	ALMA
F046	MORA2A	MORA1A	PORA2A	SLVSA	RCFNA	RCHPA	CFINA	CHPA
F047				EXOFA	SORENA	MSOVRA	INCSTA	PC1DTA
F048								
F049	ORARB	TLMB	LDT2B	LDT1B	SARB	SDTB	SSTB	ALMB

	7	6	5	4	3	2	1	0
F050	MORA2B	MORA1B	PORA2B	SLVSB	RCFNB	RCHPB	CFINB	CHPB
F051				EXOFB	SORENB	MSOVRB	INCSTB	PC1DTB
F052								
F053	EKENB			BGEACT	RPALM	RPBSY	PRGDPL	INHKY
F054	UO007	UO006	UO005	UO004	UO003	UO002	UO001	UO000
F055	UO015	UO014	UO013	UO012	UO011	UO010	UO009	UO008
F056	UO107	UO106	UO105	UO104	UO103	UO102	UO101	UO100
F057	UO115	UO114	UO113	UO112	UO111	UO110	UO109	UO108
F058	UO123	UO122	UO121	UO120	UO119	UO118	UO117	UO116
F059	UO131	UO130	UO129	UO128	UO127	UO126	UO125	UO124
F060						ESCAN	ESEND	EREND
F061							BCLP	BUCLP
F062	PRTSF			S2MES	S1MES			
F063	PSYN							
F064						TLCHI	TLNW	TLCH
F065							RGSPM	RGSP
F066			PECK2				RTPT	G08MD
F067								
F068								
F069	RMTDO7	RMTDO6	RMTDO5	RMTDO4	RMTDO3	RMTDO2	RMTDO1	RMTDO0
F070	PSW08	PSW07	PSW06	PSW05	PSW04	PSW03	PSW02	PSW01
F071	PSW16	PSW15	PSW14	PSW13	PSW12	PSW11	PSW10	PSW09
F072	OUT7	OUT6	OUT5	OUT4	OUT3	OUT2	OUT1	OUT0
F073				ZRNO		MD4O	MD2O	MD1O
F074								

	7	6	5	4	3	2	1	0
F075	SPO	KEYO	DRNO	MLKO	SBKO	BDTO		
F076			ROV2O	ROV1O	RTAP		MP2O	MP1O
F077		RTO			HS1DO	HS1CO	HS1BO	HS1AO
F078	*FV7O	*FV6O	*FV5O	*FV4O	*FV3O	*FV2O	*FV1O	*FV0O
F079	*JV7O	*JV6O	*JV5O	*JV4O	*JV3O	*JV2O	*JV1O	*JV0O
F080	*JV15O	*JV14O	*JV13O	*JV12O	*JV11O	*JV10O	*JV9O	*JV8O
F081	- J4O	+ J4O	- J3O	+ J3O	- J2O	+ J2O	- J1O	+ J1O
F082								
F083								
F084								
F085								
F086								
F087								
F088								
F089								
F090						ABTSP2	ABTSP1	ABTQSV
F091								
F092								
F093	SVWRN4	SVWRN3	SVWRN2	SVWRN1				LIFOVR
F094				ZP5	ZP4	ZP3	ZP2	ZP1
F095								
F096				ZP25	ZP24	ZP23	ZP22	ZP21
F097								
F098				ZP35	ZP34	ZP33	ZP32	ZP31
F099								

	7	6	5	4	3	2	1	0
F100				ZP45	ZP44	ZP43	ZP42	ZP41
F101								
F102				MV5	MV4	MV3	MV2	MV1
F103								
F104				INP5	INP4	INP3	INP2	INP1
F105								
F106				MVD5	MVD4	MVD3	MVD2	MVD1
F107								
F108				MMI5	MMI4	MMI3	MMI2	MMI1
F109								
F110				MDTCH5	MDTCH4	MDTCH3	MDTCH2	MDTCH1
F111								
F112				EADEN5	EADEN4	EADEN3	EADEN2	EADEN1
F113								
F114				TRQL5	TRQL4	TRQL3	TRQL2	TRQL1
F115								
F116								
F117								
F118								
F119								
F120				ZRF5	ZRF4	ZRF3	ZRF2	ZRF1
F121								
F122								HDO0
F123								
F124				+OT5	+OT4	+OT3	+OT2	+OT1

	7	6	5	4	3	2	1	0
F125								
F126				-OT5	-OT4	-OT3	-OT2	-OT1
F127								
F128								
F129	*EAXSL		EOV0					
F130	EBSYA	EOTNA	EOTPA	EGENA	EDENA	EIALA	ECKZA	EINPA
F131							EABUFA	EMFA
F132	EM28A	EM24A	EM22A	EM21A	EM18A	EM14A	EM12A	EM11A
F133	EBSYB	EOTNB	EOTPB	EGENB	EDENB	EIALB	ECKZB	EINPB
F134							EABUFB	EMFB
F135	EM28B	EM24B	EM22B	EM21B	EM18B	EM14B	EM12B	EM11B
F136	EBSYC	EOTNC	EOTPC	EGENC	EDENC	EIALC	ECKZC	EINPC
F137							EABUFC	EMFC
F138	EM28C	EM24C	EM22C	EM21C	EM18C	EM14C	EM12C	EM11C
F139	EBSYD	EOTND	EOTPD	EGEND	EDEND	EIALD	ECKZD	EINPD
F140							EABUFD	EMFD
F141	EM28D	EM24D	EM22D	EM21D	EM18D	EM14D	EM12D	EM11D
F142	EM48A	EM44A	EM42A	EM41A	EM38A	EM34A	EM32A	EM31A
F143								
F144								
F145	EM48B	EM44B	EM42B	EM41B	EM38B	EM34B	EM32B	EM31B
F146								
F147								
F148	EM48C	EM44C	EM42C	EM41C	EM38C	EM34C	EM32C	EM31C
F149								

	7	6	5	4	3	2	1	0
F150								
F151	EM48D	EM44D	EM42D	EM41D	EM38D	EM34D	EM32D	EM31D
F152								
F153								
F154								
F155								
F156								
F157								
F158								
F159								
F160								
F161								
F162								
F163								
F164								
F165								
F166								
F167								
F168								
F169								
F170								
F171								
F172	PBATL	PBATZ						
F173								
F174								

	7	6	5	4	3	2	1	0
F175								
F176								
F177	EDGN	EPARM	EVAR	EPRG	EWGIO	ESTPIO	ERDIO	IOLNK
F178					SRLNO3	SRLNO2	SRLNO1	SRLNO0
F179								
F180				CLRCH5	CLRCH4	CLRCH3	CLRCH2	CLRCH1
F181								
F182				EACNT5	EACNT4	EACNT3	EACNT2	EACNT1
F183								
F184								
F185								
F186								
F187								
F188								
F189								
F190								
F191								
F192								
F193								
F194								
F195								
F196								
F197								
F198								
F199								

	7	6	5	4	3	2	1	0
F200								
F201								
F202								
F203								
F204								
F205								
F206								
F207								
F208								
F209								
F210								
F211								
F212								
F213								
F214								
F215								
F216								
F217								
F218								
F219								
F220								
F221								
F222								
F223								
F224								

	7	6	5	4	3	2	1	0
F225								
F226								
F227								
F228								
F229								
F230								
F231								
F232								
F233								
F234								
F235								
F236								
F237								
F238								
F239								
F240								
F241								
F242								
F243								
F244								
F245								
F246								
F247								
F248								
F249								

	7	6	5	4	3	2	1	0
F250								
F251								
F252								
F253								
F254								
F255								
F256								
F257								
F258								
F259								
F260								
F261								
F262								
F263								
F264	SPWRN8	SPWRN7	SPWRN6	SPWRN5	SPWRN4	SPWRN3	SPWRN2	SPWRN1
F265								SPWRN9
F266								
F267								
F268								
F269								
F270								
F271								
F272								
F273								
F274								

	7	6	5	4	3	2	1	0
F275								
F276	UO023	UO022	UO021	UO020	UO019	UO018	UO017	UO016
F277	UO031	UO030	UO029	UO028	UO027	UO026	UO025	UO024
F278								
F279								
F280	UO207	UO206	UO205	UO204	UO203	UO202	UO201	UO200
F281	UO215	UO214	UO213	UO212	UO211	UO210	UO209	UO208
F282	UO223	UO222	UO221	UO220	UO219	UO218	UO217	UO216
F283	UO231	UO230	UO229	UO228	UO227	UO226	UO225	UO224
F284	UO307	UO306	UO305	UO304	UO303	UO302	UO301	UO300
F285	UO315	UO314	UO313	UO312	UO311	UO310	UO309	UO308
F286	UO323	UO322	UO321	UO320	UO319	UO318	UO317	UO316
F287	UO331	UO330	UO329	UO328	UO327	UO326	UO325	UO324
F288								
F289								
F290								
F291								
F292								
F293								
F294								
F295								
F296								
F297								
F298								
F299								

	7	6	5	4	3	2	1	0
F300								
F301								
F302								
F303								
F304								
F305								
F306								
F307								
F308								
F309								
F310								
F311								
F312								
F313								
F314								
F315								

A.1.4 Series 20i Address List

The following dialog shows the relationships between the addresses for the interface signals between the CNC and PMC.

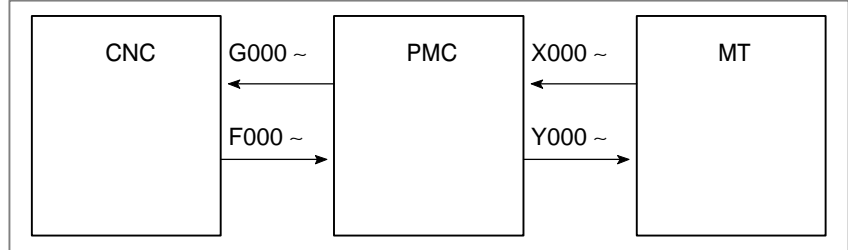

If a signal in an item common to both T and F series is disabled for either model, its name is indicated by hatching () as shown below.

[Example 1]

EXLM and ST are common to both T and F series. STLK is valid only for the T series. RLSOT is valid only for the F series.

G007	#7	#6	#2	#1	#0	
	RLSOT	EXLM	ST	STLK		
						T series F series

MT → PMC

Address	Bit number							
	7	6	5	4	3	2	1	0
X000								
X001								
X002								
X003								
X004	SKIP	ESKIP	-MIT2	+MIT2	-MIT1	+MIT1		
X005								
X006								
X007								
X008				*ESP				
X009					*DEC4	*DEC3	*DEC2	*DEC1
X010								
X011								
X012								

● T series and F series

PMC → CNC

Address	Bit number							
	7	6	5	4	3	2	1	0
G000	ED7	ED6	ED5	ED4	ED3	ED2	ED1	ED0
G001	ED15	ED14	ED13	ED12	ED11	ED10	ED9	ED8
G002	ESTB	EA6	EA5	EA4	EA3	EA2	EA1	EA0
G003								
G004			MFIN3	MFIN2	FIN			
G005		AFL			TFIN	SFIN	EFIN	MFIN
G006		SKIPP		OVC		*ABSM		SRN
G007	RLSOT	EXLM	*FLWU			ST	STLK	
G008	ERS	RRW	*SP	*ESP				*IT
G009				PN16	PN8	PN4	PN2	PN1
G010	*JV7	*JV6	*JV5	*JV4	*JV3	*JV2	*JV1	*JV0
G011	*JV15	*JV14	*JV13	*JV12	*JV11	*JV10	*JV9	*JV8
G012	*FV7	*FV6	*FV5	*FV4	*FV3	*FV2	*FV1	*FV0
G013								
G014							ROV2	ROV1
G015								
G016								
G017								
G018	HS2D	HS2C	HS2B	HS2A	HS1D	HS1C	HS1B	HS1A
G019	RT		MP2	MP1	HS3D	HS3C	HS3B	HS3A
G020					HS4D	HS4C	HS4B	HS4A
G021								
G022								
G023			HDLF					
G024								

	7	6	5	4	3	2	1	0
G025								
G026								
G027								
G028						GR2	GR1	
G029		*SSTP	SOR	SAR				
G030	SOV7	SOV6	SOV5	SOV4	SOV3	SOV2	SOV1	SOV0
G031								
G032	R08I	R07I	R06I	R05I	R04I	R03I	R02I	R01I
G033	SIND	SSIN	SGN		R12I	R11I	R10I	R09I
G034								
G035								
G036								
G037								
G038								
G039								
G040		PRC						
G041	HS2ID	HS2IC	HS2IB	HS2IA	HS1ID	HS1IC	HS1IB	HS1IA
G042					HS3ID	HS3IC	HS3IB	HS3IA
G043	ZRN		DNCI			MD4	MD2	MD1
G044							MLK	BDT1
G045								
G046	DRN	KEY4	KEY3	KEY2	KEY1		SBK	KEYPRM
G047								
G048								
G049								

	7	6	5	4	3	2	1	0
G050								
G051	*CHLD	CHPST			*CHP8	*CHP4	*CHP2	*CHP0
G052	RMTDI7	RMTDI6	RMTDI5	RMTDI4	RMTDI3	RMTDI2	RMTDI1	RMTDI0
G053	CDZ	SMZ			UINT			TMRON
G054	UI007	UI006	UI005	UI004	UI003	UI002	UI001	UI000
G055	UI015	UI014	UI013	UI012	UI011	UI010	UI009	UI008
G056	UI023	UI022	UI021	UI020	UI019	UI018	UI017	UI016
G057	UI031	UI030	UI029	UI028	UI027	UI026	UI025	UI024
G058					EXWT	EXSTP	EXRD	MINP
G059								
G060								
G061								RGTAP
G062							*CRTOF	
G063								
G064								
G065								
G066	EKSET						ENBKY	IGNVRY
G067	HCREQ	HCABT						
G068								
G069								
G070	MRDYA	ORCMA	SFRA	SRVA	CTH1A	CTH2A	TLMHA	TLMLA
G071	RCHA	RSLA	INTGA	SOCNA	MCFNA	SPSLA	*ESPA	ARSTA
G072	RCHHGA	MFNHGA	INCMDA	OVRA	DEFMDA	NRROA	ROTAA	INDXA
G073				DSCNA		MPOFA	SLVA	MORCMA
G074								

	7	6	5	4	3	2	1	0
G075								
G076								
G077								
G078	SHA07	SHA06	SHA05	SHA04	SHA03	SHA02	SHA01	SHA00
G079					SHA11	SHA10	SHA09	SHA08
G080								
G081								
G082								
G083								
G084								
G085								
G086					-Ja	+Ja	-Jg	+Jg
G087	MP42	MP41		MP32	MP31		MP22	MP21
G088	HS4ID	HS4IC	HS4IB	HS4IA				
G089								
G090								
G091					SRLNI3	SRLNI2	SRLNI1	SRLNI0
G092				BGEN	BGIALM	BGION	IOLS	IOLACK
G093								
G094								
G095								
G096	HROV	*HROV6	*HROV5	*HROV4	*HROV3	*HROV2	*HROV1	*HROV0
G097								
G098	EKC7	EKC6	EKC5	EKC4	EKC3	EKC2	EKC1	EKC0
G099								

	7	6	5	4	3	2	1	0
G100					+J4	+J3	+J2	+J1
G101								
G102					-J4	-J3	-J2	-J1
G103								
G104								
G105								
G106					MI4	MI3	MI2	MI1
G107								
G108					MLK4	MLK3	MLK2	MLK1
G109								
G110					+LM4	+LM3	+LM2	+LM1
G111								
G112					-LM4	-LM3	-LM2	-LM1
G113								
G114					*+L4	*+L3	*+L2	*+L1
G115								
G116					*-L4	*-L3	*-L2	*-L1
G117								
G118								
G119								
G120								
G121								
G122								
G123								

	7	6	5	4	3	2	1	0
G124					DTCH4	DTCH3	DTCH2	DTCH1
G125					IUDD4	IUDD3	IUDD2	IUDD1
G126					SVF4	SVF3	SVF2	SVF1
G127								
G128								
G129								
G130					*IT4	*IT3	*IT2	*IT1
G131								
G132					+MIT4	+MIT3	+MIT2	+MIT1
G133								
G134					-MIT4	-MIT3	-MIT2	-MIT1
G135								
G136					EAX4	EAX3	EAX2	EAX1
G137								
G138								
G139								
G140								
G141								
G142	EBUFA	ECLRA	ESTPA	ESOFA	ESBKA	EMBUFA	ELCKZA	EFINA
G143	EMSBKA	EC6A	EC5A	EC4A	EC3A	EC2A	EC1A	EC0A
G144	EIF7A	EIF6A	EIF5A	EIF4A	EIF3A	EIF2A	EIF1A	EIF0A
G145	EIF15A	EIF14A	EIF13A	EIF12A	EIF11A	EIF10A	EIF9A	EIF8A
G146	EID7A	EID6A	EID5A	EID4A	EID3A	EID2A	EID1A	EID0A
G147	EID15A	EID14A	EID13A	EID12A	EID11A	EID10A	EID9A	EID8A
G148	EID23A	EID22A	EID21A	EID20A	EID19A	EID18A	EID17A	EID16A

	7	6	5	4	3	2	1	0
G149	EID31A	EID30A	EID29A	EID28A	EID27A	EID26A	EID25A	EID24A
G150	DRNE	RTE	OVCE				ROV2E	ROV1E
G151	*FV7E	*FV6E	*FV5E	*FV4E	*FV3E	*FV2E	*FV1E	*FV0E
G152								
G153								
G154	EUBFB	ECLRB	ESTPB	ESOFB	ESBKB	EMBUFB	ELCKZB	EFINB
G155	EMSBKB	EC6B	EC5B	EC4B	EC3B	EC2B	EC1B	EC0B
G156	EIF7B	EIF6B	EIF5B	EIF4B	EIF3B	EIF2B	EIF1B	EIF0B
G157	EIF15B	EIF14B	EIF13B	EIF12B	EIF11B	EIF10B	EIF9B	EIF8B
G158	EID7B	EID6B	EID5B	EID4B	EID3B	EID2B	EID1B	EID0B
G159	EID15B	EID14B	EID13B	EID12B	EID11B	EID10B	EID9B	EID8B
G160	EID23B	EID22B	EID21B	EID20B	EID19B	EID18B	EID17B	EID16B
G161	EID31B	EID30B	EID29B	EID28B	EID27B	EID26B	EID25B	EID24B
G162								
G163								
G164								
G165								
G166	EUBFC	ECLRC	ESTPC	ESOFC	ESBKC	EMBUFC	ELCKZC	EFINC
G167	EMSBKC	EC6C	EC5C	EC4C	EC3C	EC2C	EC1C	EC0C
G168	EIF7C	EIF6C	EIF5C	EIF4C	EIF3C	EIF2C	EIF1C	EIF0C
G169	EIF15C	EIF14C	EIF13C	EIF12C	EIF11C	EIF10C	EIF9C	EIF8C
G170	EID7C	EID6C	EID5C	EID4C	EID3C	EID2C	EID1C	EID0C
G171	EID15C	EID14C	EID13C	EID12C	EID11C	EID10C	EID9C	EID8C
G172	EID23C	EID22C	EID21C	EID20C	EID19C	EID18C	EID17C	EID16C
G173	EID31C	EID30C	EID29C	EID28C	EID27C	EID26C	EID25C	EID24C

	7	6	5	4	3	2	1	0
G174								
G175								
G176								
G177								
G178	EBUGD	ECLRD	ESTPD	ESOFD	ESBKD	EMBUGD	ELCKZD	EFIND
G179	EMSBKD	EC6D	EC5D	EC4D	EC3D	EC2D	EC1D	EC0D
G180	EIF7D	EIF6D	EIF5D	EIF4D	EIF3D	EIF2D	EIF1D	EIF0D
G181	EIF15D	EIF14D	EIF13D	EIF12D	EIF11D	EIF10D	EIF9D	EIF8D
G182	EID7D	EID6D	EID5D	EID4D	EID3D	EID2D	EID1D	EID0D
G183	EID15D	EID14D	EID13D	EID12D	EID11D	EID10D	EID9D	EID8D
G184	EID23D	EID22D	EID21D	EID20D	EID19D	EID18D	EID17D	EID16D
G185	EID31D	EID30D	EID29D	EID28D	EID27D	EID26D	EID25D	EID24D
G186								
G187								
G188								
G189								
G190								
G191								
G192					IGVRY4	IGVRY3	IGVRY2	IGVRY1
G193								
G194								
G195								
G196								
G197								
G198					NPOS4	NPOS3	NPOS2	NPOS1

	7	6	5	4	3	2	1	0
G199							IOLBH3	IOLBH2
G200								
G201			JGRD3	JGRD2	JGRD1			
G202								
G203								
G204								
G205								
G206								
G207								
G208								
G209								
⋮								
⋮								
G276	UI107	UI106	UI105	UI104	UI103	UI102	UI101	UI100
G277	UI115	UI114	UI113	UI112	UI111	UI110	UI109	UI108
G278	UI123	UI122	UI121	UI120	UI119	UI118	UI117	UI116
G279	UI131	UI130	UI129	UI128	UI127	UI126	UI125	UI124
G280	UI207	UI206	UI205	UI204	UI203	UI202	UI201	UI200
G281	UI215	UI214	UI213	UI212	UI211	UI210	UI209	UI208
G282	UI223	UI222	UI221	UI220	UI219	UI218	UI217	UI216
G283	UI231	UI230	UI229	UI228	UI227	UI226	UI225	UI224
G284	UI307	UI306	UI305	UI304	UI303	UI302	UI301	UI300
G285	UI315	UI314	UI313	UI312	UI311	UI310	UI309	UI308
G286	UI323	UI322	UI321	UI320	UI319	UI318	UI317	UI316
G287	UI331	UI330	UI329	UI328	UI327	UI326	UI325	UI324

CNC → PMC

Address	Bit number							
	7	6	5	4	3	2	1	0
F000	OP	SA	STL	SPL				RWD
F001	MA		TAP	ENB	DEN	BAL	RST	AL
F002	MDRN	CUT		SRNMV	THRD	CSS	RPDO	INCH
F003	MTCHIN	MEDT	MMEM	MRMT	MMDI	MJ	MH	
F004			MREF	MAFL	MSBK	MABSM	MMLK	MBDT1
F005								
F006								
F007					TF	SF	EFD	MF
F008			MF3	MF2				EF
F009	DM00	DM01	DM02	DM30				
F010	M07	M06	M05	M04	M03	M02	M01	M00
F011	M15	M14	M13	M12	M11	M10	M09	M08
F012	M23	M22	M21	M20	M19	M18	M17	M16
F013	M31	M30	M29	M28	M27	M26	M25	M24
F014	M207	M206	M205	M204	M203	M202	M201	M200
F015	M215	M214	M213	M212	M211	M210	M209	M208
F016	M307	M306	M305	M304	M303	M302	M301	M300
F017	M315	M314	M313	M312	M311	M310	M309	M308
F018								
F019								
F020								
F021								
F022	S07	S06	S05	S04	S03	S02	S01	S00
F023	S15	S14	S13	S12	S11	S10	S09	S08
F024	S23	S22	S21	S20	S19	S18	S17	S16

	7	6	5	4	3	2	1	0
F025	S31	S30	S29	S28	S27	S26	S25	S24
F026	T07	T06	T05	T04	T03	T02	T01	T00
F027	T15	T14	T13	T12	T11	T10	T09	T08
F028	T23	T22	T21	T20	T19	T18	T17	T16
F029	T31	T30	T29	T28	T27	T26	T25	T24
F030								
F031								
F032								
F033								
F034	SRSRDY	SRSP1R				GR3O	GR2O	GR1O
F035								
F036	R08O	R07O	R06O	R05O	R04O	R03O	R02O	R01O
F037					R12O	R11O	R10O	R09O
F038								
F039					CHPCYL	CHPMD		
F040								
F041								
F042								
F043								
F044								
F045	ORARA	TLMA	LDT2A	LDT1A	SARA	SDTA	SSTA	ALMA
F046	MORA2A	MORA1A	PORA2A	SLVSA	RCFNA	RCHPA	CFINA	CHPA
F047				EXOFA			INCSTA	PC1DEA
F048								
F049								

	7	6	5	4	3	2	1	0
F050								
F051								
F052								
F053	EKENB			BGEACT	RPALM	RPBSY	PRGDPL	INHKY
F054	UO007	UO006	UO005	UO004	UO003	UO002	UO001	UO000
F055	UO015	UO014	UO013	UO012	UO011	UO010	UO009	UO008
F056	UO107	UO106	UO105	UO104	UO103	UO102	UO101	UO100
F057	UO115	UO114	UO113	UO112	UO111	UO110	UO109	UO108
F058	UO123	UO122	UO121	UO120	UO119	UO118	UO117	UO116
F059	UO131	UO130	UO129	UO128	UO127	UO126	UO125	UO124
F060							ESEND	EREND
F061					HCEXE	HCAB2		
F062	PRTSF							AICC
F063								
F064								
F065							RGSPM	RGSP
F066						FEED0		G08MD
F067								
F068								
F069	RMTDO7	RMTDO6	RMTDO5	RMTDO4	RMTDO3	RMTDO2	RMTDO1	RMTDO0
F070								
F071								
F072	OUT7	OUT6	OUT5	OUT4	OUT3	OUT2	OUT1	OUT0
F073				ZRNO		MD40	MD20	MD10
F074								

	7	6	5	4	3	2	1	0
F075	SPO	KEYO	DRNO	MLKO	SBKO	BDO		
F076			ROV2O	ROV1O	RTAP		MP2O	MP1O
F077		RTO			HS1DO	HS1CO	HS1BO	HS1AO
F078	*FV7O	*FV6O	*FV5O	*FV4O	*FV3O	*FV2O	*FV1O	*FV0O
F079	*JV7O	*JV6O	*JV5O	*JV4O	*JV3O	*JV2O	*JV1O	*JV0O
F080	*JV15O	*JV14O	*JV13O	*JV12O	*JV11O	*JV10O	*JV9O	*JV8O
F081	- J4O	+ J4O	- J3O	+ J3O	- J2O	+ J2O	- J1O	+ J1O
F082								
F083								
F084								
F085								
F086								
F087								
F088								
F089								
F090							ABTSP1	ABTQSV
F091								
F092								
F093	SVWRN4	SVWRN3	SVWRN2	SVWRN1				LIFOVR
F094					ZP4	ZP3	ZP2	ZP1
F095								
F096					ZP24	ZP23	ZP22	ZP21
F097								
F098								
F099								

	7	6	5	4	3	2	1	0
F100								
F101								
F102					MV4	MV3	MV2	MV1
F103								
F104					INP4	INP3	INP2	INP1
F105								
F106					MVD4	MVD3	MVD2	MVD1
F107								
F108					MMI4	MMI3	MMI2	MMI1
F109								
F110					MDTCH4	MDTCH3	MDTCH2	MDTCH1
F111								
F112					EADEN4	EADEN3	EADEN2	EADEN1
F113								
F114							TRQL2	TRQL1
F115								
F116								
F117								
F118								
F119								
F120					ZRF4	ZRF3	ZRF2	ZRF1
F121								
F122								HDO0
F123								
F124								

	7	6	5	4	3	2	1	0
F125								
F126								
F127								
F128								
F129	*EAXSL		EOV0					
F130	EBSYA	EOTNA	EOTPA	EGENA	EDENA	EIALA	ECKZA	EINPA
F131							EABUFA	EMFA
F132	EM28A	EM24A	EM22A	EM21A	EM18A	EM14A	EM12A	EM11A
F133	EBSYB	EOTNB	EOTPB	EGENB	EDENB	EIALB	ECKZB	EINPB
F134							EABUFB	EMFB
F135	EM28B	EM24B	EM22B	EM21B	EM18B	EM14B	EM12B	EM11B
F136	EBSYC	EOTNC	EOTPC	EGENC	EDENC	EIALC	ECKZC	EINPC
F137							EABUFC	EMFC
F138	EM28C	EM24C	EM22C	EM21C	EM18C	EM14C	EM12C	EM11C
F139	EBSYD	EOTND	EOTPD	EGEND	EDEND	EIALD	ECKZD	EINPD
F140							EABUFD	EMFD
F141	EM28D	EM24D	EM22D	EM21D	EM18D	EM14D	EM12D	EM11D
F142	EM48A	EM44A	EM42A	EM41A	EM38A	EM34A	EM32A	EM31A
F143								
F144								
F145	EM48B	EM44B	EM42B	EM41B	EM38B	EM34B	EM32B	EM31B
F146								
F147								
F148	EM48C	EM44C	EM42C	EM41C	EM38C	EM34C	EM32C	EM31C
F149								

	7	6	5	4	3	2	1	0
F150								
F151	EM48D	EM44D	EM42D	EM41D	EM38D	EM34D	EM32D	EM31D
F152								
F153								
F154								
F155								
F156								
F157								
F158								
F159								
F160								
F161								
F162								
F163								
F164								
F165								
F166								
F167								
F168								
F169								
F170								
F171								
F172	PBATL	PBATZ						
F173								
F174								

	7	6	5	4	3	2	1	0
F175								
F176								
F177	EDGN	EPARM	EVAR	EPRG	EWLIO	ESTPIO	ERDIO	IOLNK
F178					SRLNO3	SRLNO2	SRLNO1	SRLNO0
F179								
F180								
F181								
F182					EACNT4	EACNT3	EACNT2	EACNT1
F183								
F184								
F185								
F186								
F187								
F188								
F189								
F190								
F191								
F192								
F193								
F194								
F195								
:								
F264	SPWRN8	SPWRN7	SPWRN6	SPWRN5	SPWRN4	SPWRN3	SPWRN2	SPWRN1

	7	6	5	4	3	2	1	0
F265								SPWRN9
⋮					⋮			
F276	UO023	UO022	UO021	UO020	UO019	UO018	UO017	UO016
F277	UO031	UO030	UO029	UO028	UO027	UO026	UO025	UO024
F278								
F279								
F280	UO207	UO206	UO205	UO204	UO203	UO202	UO201	UO200
F281	UO215	UO214	UO213	UO212	UO211	UO210	UO209	UO208
F282	UO223	UO222	UO221	UO220	UO219	UO218	UO217	UO216
F283	UO231	UO230	UO229	UO228	UO227	UO226	UO225	UO224
F284	UO307	UO306	UO305	UO304	UO303	UO302	UO301	UO300
F285	UO315	UO314	UO313	UO312	UO311	UO310	UO309	UO308
F286	UO323	UO322	UO321	UO320	UO319	UO318	UO317	UO316
F287	UO331	UO330	UO329	UO328	UO327	UO326	UO325	UO324
⋮					⋮			
F298					TDF4	TDF3	TDF2	TDF1

A.2 SIGNAL SUMMARY

A.2.1 Signal Summary (In Order of Functions)

○	: Available
●	: Available only with 2-path control
-	: Unavailable

Function	Signal name	Symbol	Address	T series	M series	Section
Data input/output with I/O Link	Power Mate background operation signal	BGEN	G092#4	○	○	13.8
	Power Mate read/write alarm signal	BGIALM	G092#3	○	○	13.8
	Power Mate read/write busy signal	BGION	G092#2	○	○	13.8
	Slave diagnosis selection signal	EDGN	F177#7	○	○	13.8
	Slave parameter selection signal	EPARM	F177#6	○	○	13.8
	Slave program selection signal	EPRG	F177#4	○	○	13.8
	Slave external read start signal	ERDIO	F177#1	○	○	13.8
	Slave read/write stop signal	ESTPIO	F177#2	○	○	13.8
	Slave macro variable selection signal	EVAR	F177#5	○	○	13.8
	Slave external write start signal	EWGIO	F177#3	○	○	13.8
	External read start signal	EXRD	G058#1	○	○	13.8, 13.5
	External read/punch stop signal	EXSTP	G058#2	○	○	13.8, 13.5
	External punch start signal	EXWT	G058#3	○	○	13.8, 13.5
	I/O Link check signal	IOLACK	G092#0	○	○	13.8
	Slave I/O Link selection signal	IOLINK	F177#0	○	○	13.8
	I/O Link specification signal	IOLS	G092#1	○	○	13.8
	Read/punch alarm signal	RPALM	F053#3	○	○	13.8, 13.5
	Read/punch busy signal	RPBSY	F053#2	○	○	13.8, 13.5
Group number specification signals	SRLNI0 to SRLNI3	G091#0 to #3	○	○	13.8	
Group number output signals	SRLNO0 to SRLNO3	F178#0 to #3	○	○	13.8	
External I/O device control	External read start signal	EXRD	G058#1	○	○	13.5
	External punch start signal	EXWT	G058#3	○	○	
	External read/punch stop signal	EXSTP	G058#2	○	○	
	Background editing signal	BGEACT	F053#4	○	○	
	Read/punch busy signal	RPBSY	F053#2	○	○	
	Read/punch alarm signal	RPALM	F053#3	○	○	
α i servo warning interface	Servo warning detail signals	SVWRN1 to 4	F093#4 to #7	○	○	18.3

Function	Signal name	Symbol	Address	T series	M series	Section
α i spindle warning interface	Spindle warning detailed signals	SPWRN1 to 9	F264#0 to #7, F265#0	○	○	18.4
Alarm signal	Alarm signal	AL	F001#0	○	○	2.4
	Battery alarm signal	BAL	F001#2	○	○	
Abnormal load detection	Abnormal load detection ignore signal	IUDD1 to IUDD8	G125	○	○	2.10
	Servo axis abnormal load detected signal	ABTQSV	F090#0	○	○	
	First-spindle abnormal load detected signal	ABTSP1	F090#1	○	○	
	Second-spindle abnormal load detected signal	ABTSP2	F090#2	○	○	9.15
Third-spindle abnormal load detected signal	ABTSP3	F090#3	○	○		
Position display neglect	Position display neglect signals	NPOS1 to NPOS8	G198	○	○	12.1.10
Multiple M commands in a single block	2nd M function code signals	M200 to M215	F014 to F015	○	○	8.3
	3rd M function code signals	M300 to M315	F016 to F017	○	○	
	2nd M function strobe signal	MF2	F008#4	○	○	
	3rd M function strobe signal	MF3	F008#5	○	○	
Inch/metric conversion	Inch input signal	INCH	F002#0	○	○	11.4
Index table indexing (M series)	B-axis clamp signal	BCLP	F061#1	—	○	11.11
	B-axis clamp completion signal	*BECLP	G038#7	—	○	
	B-axis unclamp signal	BUCLP	F061#0	—	○	
	B-axis unclamp completion signal	*BEUCP	G038#6	—	○	
In-position check	In-position signals	INP1 to INP8	F104	○	○	7.2.6.1
AI contour control / AI nano contour control / AI advanced control	AI contour control, AI nano contour control, or AI advanced control mode signal	AICC	F062#0	—	○	7.1.16 7.1.17
F 1-digit feed (M series)	F 1-digit feed selection signal	F1D	G016#7	—	○	7.1.5
Error detection (T series)	Error detection signal	SMZ	G053#6	○	—	7.2.6.3
Overtravel signal	Overtravel signals	*+L1 to *+L8	G114	○	○	2.3.1
		*-L1 to *-L8	G116	○	○	
Override cancel	Override cancel signal	OVC	G006#4	○	○	7.1.7.4
Feedrate override	Feedrate override signals	*FV0 to *FV7	G012	○	○	7.1.7.2
Optional block skip/addition of optional block skip	Optional block skip signals	BDT1, BDT2 to BDT9	G044#0, G045	○	○	5.5
	Optional block skip check signals	MBDT1, MBDT2 to MBDT9	G004#0, F005	○	○	
Rotation area interference check	Rotation area interference check disable signal	ITCD	G292#7	○	○	2.3.7

Function	Signal name	Symbol	Address	T series	M series	Section
External key input	External key input mode selection signal	ENBKY	G066#1	○	○	15.5
	Key code signals	EKC0 to EKC7	G098	○	○	
	Key code read signal	EKSET	G066#7	○	○	
	Key code read completion signal	EKENB	F053#7	○	○	
	Key input disable signal	INHKY	F053#0	○	○	
	Program screen display mode signal	PRGDPL	F053#1	○	○	
External deceleration	External deceleration signals	*+ED1 to *+ED8	G118	○	○	7.1.9
		*-ED1 to *-ED8	G120	○	○	
External data input	Data signals for external data input	ED0 to ED15	G000, G001	○	○	15.2
	Address signals for external data input	EA0 to EA6	G002#0 to #6	○	○	
	Read signal for external data input	ESTB	G002#7	○	○	
	Read completion signal for external data input	EREND	F060#0	○	○	
	Search completion signal for external data input	ESEND	F060#1	○	○	
	Search cancel signal for external data input	ESCAN	F060#2	○	○	
External motion function (M series)	External operation signal	EF	F008#0	—	○	11.8
External program input	External program input start signal	MINP	G058#0	○	○	13.7
External workpiece number search	Workpiece number search signals	PN1, PN2, PN4, PN8, PN16	G009#0 to 4	○	○	15.3
Expanded External Workpiece Number Search	Expanded workpiece number search signals	EPN0 to EPN13	G024#0 to G025#5	○	○	15.3.2
	Expanded workpiece number search start signal	EPNS	G025#7	○	○	
Custom macro signal	Input signals for custom macro	UI000 to UI015	G054, G055	○	○	11.6.1
	Input signals for custom macro (Extended signals)	UI016 to UI031 UI100 to UI131 UI200 to UI231 UI300 to UI331	G056, G057 G276 to G279 G280 to G283 G284 to G287	○	○	
	Output signals for custom macro	UO000 to UO015	F054, F055	○	○	
		UO100 to UO131	F056 to F059	○	○	
	Output signals for custom macro (Extended signals)	UO016 to UO031 UO200 to UO231 UO300 to UO331	F276, F277 F280 to F283 F284 to F287	○	○	
Run hour and part count display	Target part count reached signal	PRTSF	F062#7	○	○	12.1.11
	General-purpose integrating meter start signal	TMRON	G053#0	○	○	
Screen hard copy function	Hard copy stop request signal	HCABT	G067#6	○	○	13.9
	Hard copy request signal	HCREQ	G067#7	○	○	
	Hard copy stop request acceptance flag	HCAB2	F061#2	○	○	
	Hard copy in-progress signal	HCEXE	F061#3	○	○	

Function	Signal name	Symbol	Address	T series	M series	Section
Screen erase/automatic screen erase	Automatic screen erase disable signal	*CRTOF	G062#1	○	○	12.1.19
Hobbing machine function (M series) Simple electronic gearbox (M series) General-purpose retract	Retract signal	RTRCT	G066#4	○	○	1.13 1.14.1 1.14.2 1.14.4 1.16
	Retract completed signal	RTRCTF	F065#4	○	○	1.13 1.14.1 1.14.2 1.14.4 1.16
	EGB mode signal	SYNMOD	F065#6	—	○	1.13 1.14
Simple synchronous control	Simple synchronous axis selection signals	SYNC1 to SYNC8	G138	○	○	1.6
	Simple synchronous manual feed axis selection signals	SYNCJ1 to SYNCJ8	G140	—	○	
Angular axis control/arbitrary-axis angular axis control	Angular axis control disable signal for perpendicular axis	NOZAGC	G063#5	○	○	1.11
Path selection	Path selection signal (tool post selection signal)	HEAD	G063#0	●	●	2.7
Tool axis direction handle feed function/tool axis direction handle feed B (M series)	Tool axis direction handle feed mode signal	ALNGH	G023#7	—	○	3.4.1
	Tool axis right-angle direction handle feed mode signal	RGHTH	G023#6	—	○	3.4.2
Tool life management	Tool change signal	TLCH	F064#0	○	○	10.3
	Tool change reset signal	TLRST	G048#7	○	○	
	Individual tool change signal	TLCHI	F064#2	—	○	
	Tool life arrival notice signal	TLCHB	F064#3	—	○	10.3.3
	Individual tool change reset signal	TLRSTI	G048#6	—	○	10.3
	Tool skip signal	TLSKP	G048#5	○	○	
	New tool selection signal	TLNW	F064#1	○	○	
	Tool group number selection signals	TL01 to TL256	G047#0 to G048#0	—	○	
		TL01 to TL64	G047#0 to #6	○	—	
Tool life count override signals	*TLV0 to *TLV9	G049#0 to G050#1	—	○		
Tool retraction and return	Tool retraction signal	TRESC	G059#0	○	○	5.8
	Tool retraction mode signal	TRACT	F092#3	○	○	
	Tool return signal	TRRTN	F059#1	○	○	
	Tool return completion signal	TRSPS	F092#5	○	○	

Function	Signal name	Symbol	Address	T series	M series	Section
Automatic tool length measurement (M series)/automatic tool offset (T series)	Measuring position reached signals	XAE	X004#0	○	○	14.2
		YAE	X004#1	—	○	
		ZAE	X004#2	—	○	
		ZAE	X004#1	○	—	
Direct input of tool offset value measured B (T series)	Tool offset value write mode selection signal	GOQSM	G039#7	○	—	14.4.2
	Tool offset value write signals	+MIT1, +MIT2	X004#2, #4	○	—	
		—MIT1, —MIT2	X004#3, #5	○	—	
	Tool offset number selection signals	OFN0 to OFN5, OFN6	G039#0 to #5, G040#0	○	—	
	Workpiece coordinate system shift value write mode selection signal	WOQSM	G039#6	○	—	
Workpiece coordinate system shift value write signal	WOSET	G040#7	○	—		
Input of tool offset value measured A (T series)	Position record signal	PRC	G040#6	○	—	14.4.1
High-speed M/S/T/B interface	Miscellaneous function completion signal	MFIN	G005#0	○	○	8.4
	Spindle function completion signal	SFIN	G005#2	○	○	
	Tool function completion signal	TFIN	G005#3	○	○	
	2nd auxiliary function completion signal	BFIN	G005#4	○	—	
		BFIN	G005#7	—	○	
	2nd M function completion signal	MFIN2	G004#4	○	○	
	3rd M function completion signal	MFIN3	G004#5	○	○	
	External operation signal for high-speed interface	EFD	F007#1	—	○	
External operation function completion signal	EFIN	G005#1	—	○		
High-speed cycle machining skip function	Skip signals for high-speed cycle machining	HCSKP1 to HCSKP4	G065#4 to 7	○	○	11.19
High-speed skip signal	High-speed skip status signals	HDO0 to HDO7	F122	○	○	14.3.2
Trouble diagnosis	Trouble forecast signals	TDF1 to 8	F298#0 to #7	○	○	18.1.6
Canned cycle (M series)/canned cycle for hole machining (T series)	Tapping signal	TAP	F001#5	○	○	11.7
Servo off (mechanical handle)	Servo off signals	SVF1 to SVF8	G126	○	○	1.2.8
Servo/spindle motor velocity detection	Motor velocity detection function enable signal	MSDFON	G016#0	○	○	2.11
	Servo motor velocity detection signals	DSV1 to DSV8	Y(n+0)	○	○	
	Spindle motor velocity detection signals	DSP1, DSP2, DSP3	Y(n+1)#0 to #2	○	○	

Function	Signal name	Symbol	Address	T series	M series	Section
Cycle start/feed hold	Cycle start signal	ST	G007#2	○	○	5.1
	Feed hold signal	*SP	G008#5	○	○	
	Automatic operation signal	OP	F000#7	○	○	
	Cycle start lamp signal	STL	F000#5	○	○	
	Feed hold lamp signal	SPL	F000#4	○	○	
Cs contour control	Cs contour control change signal	CON	G027#7	○	○	9.9
	Cs contour control change completion signal	FSCSL	F044#1	○	○	
Cs-axis coordinate establishment function	Cs-axis coordinate establishment request signal	CSF11	G274#4	○	○	9.9.2
	Cs-axis coordinate establishment alarm signal	CSFO1	F274#4	○	○	
	Cs-axis coordinate establishment status signal	CSPENA	F048#4	○	○	
Outputting the movement state of an axis	Axis moving signals	MV1 to MV8	F102	○	○	1.2.5
	Axis moving direction signals	MVD1 to MVD8	F106	○	○	
Actual spindle speed output	Actual spindle speed signals	AR0 to AR15	F040, F041	○	—	9.7
Constant surface speed control	Constant surface speed signal	CSS	F002#2	○	○	9.5
Spindlepositioning	Spindle stop completion signal	SPSTP	G028#6	○	—	9.8
	Spindle unclamp signal	SUCLP	F038#1	○	—	
	Spindle unclamp completion signal	*SUCPF	G028#4	○	—	
	Spindle clamp signal	SCLP	F038#0	○	—	
	Spindle clamp completion signal	*SCPF	G028#5	○	—	
Spindleorientation	Spindle orientation external stop position command signals	SHA00 to SHA11	G078#0 to G079#3	○	○	9.13
		SHB00 to SBH11	G080#0 to G081#3	○	○	
		SHC00 to SHC11	G208#0 to G209#3	○	○	9.15
		SHD00 to SHD11	G270#0 to G270#3	○	○	
Spindle simple synchronous control	Spindle simple synchronous control signal	ESRSYC	G064#6	○	○	9.16
	First spindle parking signal	PKESS1	G122#6 (G031#6)	○	○	
	Second spindle parking signal	PKESS2	G122#7 (G031#7)	○	○	
	Phase error monitor signal	SYCAL	F044#4	○	○	
Polygonalturning with two spindles	Polygon spindle stop signal	*PLSST	G038#0	○	—	6.10.2
	Spindle polygon speed reached signal	PSAR	F063#2	○	—	
	Master axis not reached signal	PSE1	F063#0	○	—	
	Polygon synchronous axis not reached signal	PSE2	F063#1	○	—	

Function	Signal name	Symbol	Address	T series	M series	Section
Spindle serial output/spindle analog output	Torque limit command LOW signals (serial spindle)	TLMLA	G070#0	○	○	9.2 9.15
		TLMLB	G074#0	○	○	
		TLMLC	G204#0	○	○	
		TLMLD	G266#0	○	○	
	Torque limit command HIGH signals (serial spindle)	TLMHA	G070#1	○	○	
		TLMHB	G074#1	○	○	
		TLMHC	G204#1	○	○	
		TLMHD	G266#1	○	○	
	Clutch/gear signals (serial spindle)	CTH1A, CTH2A	G070#3, #2	○	○	
		CTH1B, CTH2B	G074#3, #2	○	○	
		CTH1C, CTH2C	G204#3, #2	○	○	
		CTH1D, CTH2D	G266#3, #2	○	○	
	CCW command signals (serial spindle)	SRVA	G070#4	○	○	
		SRVB	G074#4	○	○	
		SRVC	G204#4	○	○	
		SRVD	G266#4	○	○	
	CW command signals (serial spindle)	SFRA	G070#5	○	○	
		SFRB	G074#5	○	○	
		SFRC	G204#5	○	○	
		SFRD	G266#5	○	○	
	Orientation command signals (serial spindle)	ORCMA	G070#6	○	○	
		ORCMB	G074#6	○	○	
		ORCMC	G204#6	○	○	
		ORCMD	G266#6	○	○	
	Machine ready signals (serial spindle)	MRDYA	G070#7	○	○	
		MRDYB	G074#7	○	○	
		MRDYC	G204#7	○	○	
		MRDYD	G266#7	○	○	
	Alarm reset signals (serial spindle)	ARSTA	G071#0	○	○	
		ARSTB	G075#0	○	○	
		ARSTC	G205#0	○	○	
		ARSTD	G267#0	○	○	
Emergency stop signals (serial spindle)	*ESPA	G071#1	○	○		
	*ESPB	G075#1	○	○		
	*ESPC	G205#1	○	○		
	*ESPD	G267#1	○	○		

Function	Signal name	Symbol	Address	T series	M series	Section
Spindle serial output/spindle analog output	Spindle selection signals (serial spindle)	SPSLA	G071#2	○	○	9.2 9.15
		SPSLB	G075#2	○	○	
		SPSLC	G205#2	○	○	
		SPSLD	G267#2	○	○	
	Power line switch completion signals (serial spindle)	MCFNA	G071#3	○	○	
		MCFNB	G075#3	○	○	
		MCFNC	G205#3	○	○	
		MCFND	G267#3	○	○	
	Soft start/stop cancel signals (serial spindle)	SOCNA	G071#4	○	○	
		SOCNB	G075#4	○	○	
		SOCNC	G205#4	○	○	
		SOCND	G267#4	○	○	
	Speed integral signals (serial spindle)	INTGA	G071#5	○	○	
		INTGB	G075#5	○	○	
		INTGC	G205#5	○	○	
		INTGD	G267#5	○	○	
	Output switch request signals (serial spindle)	RSLA	G071#6	○	○	
		RSLB	G075#6	○	○	
		RSLC	G205#6	○	○	
		RSLD	G267#6	○	○	
	Power line status check signals (serial spindle)	RCHA	G071#7	○	○	
		RCHB	G075#7	○	○	
		RCHC	G205#7	○	○	
		RCHD	G267#7	○	○	
	Orientation stop position change command signals (serial spindle)	INDXA	G072#0	○	○	
		INDXB	G076#0	○	○	
		INDXC	G206#0	○	○	
		INDXD	G268#0	○	○	
	Rotational direction command signals for orientation stop position change (serial spindle)	ROTAA	G072#1	○	○	
		ROTAB	G076#1	○	○	
		ROTAC	G206#1	○	○	
		ROTAD	G268#1	○	○	
Shortcut command signals for orientation stop position change (serial spindle)	NRROA	G072#2	○	○		
	NRROB	G076#2	○	○		
	NRROC	G206#2	○	○		
	NRROD	G268#2	○	○		

Function	Signal name	Symbol	Address	T series	M series	Section
Spindle serial output/spindle analog output	Differential speed mode command signals (serial spindle)	DEFMDA	G072#3	○	○	9.2 9.15
		DEFMDB	G076#3	○	○	
		DEFMDC	G206#3	○	○	
		DEFMDD	G268#3	○	○	
	Analog override signals (serial spindle)	OVRA	G072#4	○	○	
		OVRB	G076#4	○	○	
		OVRC	G206#4	○	○	
		OVRD	G268#4	○	○	
	Incremental command externally set orientation signals (serial spindle)	INCMDA	G072#5	○	○	
		INCMDB	G076#5	○	○	
		INCMDC	G206#5	○	○	
		INCMDD	G268#5	○	○	
	Spindle switch MAIN MCC contact status signals (serial spindle)	MFNHGA	G072#6	○	○	
		MFNHGB	G076#6	○	○	
		MFNHGC	G206#6	○	○	
		MFNHGD	G268#6	○	○	
	Spindle switch HIGH MCC contact status signals (serial spindle)	RCHHGA	G072#7	○	○	
		RCHHGB	G076#7	○	○	
		RCHHGC	G206#7	○	○	
		RCHHGD	G268#7	○	○	
	Magnetic sensor orientation command signals (serial spindle)	MORCMA	G073#0	○	○	
		MORCMB	G077#0	○	○	
		MORCMC	G207#0	○	○	
		MORCMD	G269#0	○	○	
	Subordinate operation mode command signals (serial spindle)	SLVA	G073#1	○	○	
		SLVB	G077#1	○	○	
		SLVC	G207#1	○	○	
		SLVD	G269#1	○	○	
	Motor power cutoff command signals (serial spindle)	MPOFA	G073#2	○	○	
		MPOFB	G077#2	○	○	
		MPOFC	G207#2	○	○	
		MPOFD	G269#2	○	○	
Disconnection detection disable signal	DSCNA	G073#4	○	○		
	DSCNB	G077#4	○	○		
	DSCNC	G207#4	○	○		
	DSCND	G269#4	○	○		

Function	Signal name	Symbol	Address	T series	M series	Section
Spindle serial output/spindle analog output	Alarm signals (serial spindle)	ALMA	F045#0	○	○	9.2 9.15
		ALMB	F049#0	○	○	
		ALMC	F168#0	○	○	
		ALMD	F266#0	○	○	
	Speed zero signals (serial spindle)	SSTA	F045#1	○	○	
		SSTB	F049#1	○	○	
		SSTC	F168#1	○	○	
		SSTD	F266#1	○	○	
	Speed detection signals (serial spindle)	SDTA	F045#2	○	○	
		SDTB	F049#2	○	○	
		SDTC	F168#2	○	○	
		SDTD	F266#2	○	○	
	Speed arrival signals (serial spindle)	SARA	F045#3	○	○	
		SARB	F049#3	○	○	
		SARC	F168#3	○	○	
		SARD	F266#3	○	○	
	Load detection signals 1 (serial spindle)	LDT1A	F045#4	○	○	
		LDT1B	F049#4	○	○	
		LDT1C	F168#4	○	○	
		LDT1D	F266#4	○	○	
	Load detection signals 2 (serial spindle)	LDT2A	F045#5	○	○	
		LDT2B	F049#5	○	○	
		LDT2C	F168#5	○	○	
		LDT2D	F266#5	○	○	
	Torque limit signals (serial spindle)	TLMA	F045#6	○	○	
		TLMB	F049#6	○	○	
		TLMC	F168#6	○	○	
		TLMD	F266#6	○	○	
	Orientation completion signals (serial spindle)	ORARA	F045#7	○	○	
		ORARB	F049#7	○	○	
		ORARC	F168#7	○	○	
		ORARD	F266#7	○	○	
Power line switch signals (serial spindle)	CHPA	F046#0	○	○		
	CHPB	F050#0	○	○		
	CHPC	F169#0	○	○		
	CHPD	F267#0	○	○		

Function	Signal name	Symbol	Address	T series	M series	Section
Spindle serial output/spindle analog output	Spindle switch completion signals (serial spindle)	CFINA	F046#1	○	○	9.2 9.15
		CFINB	F050#1	○	○	
		CFINC	F169#1	○	○	
		CFIND	F267#1	○	○	
	Output switch signals (serial spindle)	RCHPA	F046#2	○	○	
		RCHPB	F050#2	○	○	
		RCHPC	F169#2	○	○	
		RCHPD	F267#2	○	○	
	Output switch completion signals (serial spindle)	RCFNA	F046#3	○	○	
		RCFNB	F050#3	○	○	
		RCFNC	F169#3	○	○	
		RCFND	F267#3	○	○	
	Subordinate operation status signals (serial spindle)	SLVSA	F046#4	○	○	
		SLVSB	F050#4	○	○	
		SLVSC	F169#4	○	○	
		SLVSD	F267#4	○	○	
	Position coder orientation proximity signal (serial spindle)	PORA2A	F046#5	○	○	
		PORA2B	F050#5	○	○	
		PORA2C	F169#5	○	○	
		PORA2D	F267#5	○	○	
	Magnetic sensor orientation completion signals (serial spindle)	MORA1A	F046#6	○	○	
		MORA1B	F050#6	○	○	
		MORA1C	F169#6	○	○	
		MORA1D	F267#6	○	○	
	Magnetic sensor orientation proximity signals (serial spindle)	MORA2A	F046#7	○	○	
		MORA2B	F050#7	○	○	
		MORA2C	F169#7	○	○	
		MORA2D	F267#7	○	○	
	Position coder one-rotation signal detection status signals (serial spindle)	PC1DTA	F047#0	○	○	
		PC1DTB	F051#0	○	○	
		PC1DTC	F170#0	○	○	
		PC1DTD	F268#0	○	○	
Incremental orientation mode signals (serial spindle)	INCSTA	F047#1	○	○		
	INCSTB	F051#1	○	○		
	INCSTC	F170#1	○	○		
	INCSTD	F268#1	○	○		

Function	Signal name	Symbol	Address	T series	M series	Section
Spindle serial output/spindle analog output	Motor activation off status signal	EXOFA	F047#4	○	○	9.2 9.15
		EXOFB	F051#4	○	○	
		EXOFC	F170#4	○	○	
		EXOFD	F268#4	○	○	
Spindle speed control	Spindle stop signal	*SSTP	G029#6	○	○	9.3
	Spindle orientation signal	SOR	G029#5	○	○	
	Spindle speed override signals	SOV0 to SOV7	G030	○	○	
	Spindle speed arrival signal	SAR	G029#4	○	○	
	Spindle enable signal	ENB	F001#4	○	○	
	Gear selection signals (output)	GR10, GR20, GR30	F034#0 to #2	—	○	
	Gear selection signals (input)	GR1, GR2	G028#1, #2	○	○	
S 12-bit code signals	R010 to R120	F036#0 to F037#3	○	○		
Spindle speed fluctuation detection	Spindle fluctuation detection alarm signal	SPAL	F035#0	○	○	9.6
Spindle synchronous control	Spindle synchronous control signal	SPSYC	G038#2	○	○	9.12
	Spindle phase synchronous control signal	SPPHS	G038#3	○	○	
	Spindle synchronous speed control completion signal	FSPSY	F044#2	○	○	
	Spindle phase synchronous control completion signal	FSPPH	F044#3	○	○	
	Phase error monitor signal	SYCAL	F044#4	○	○	
Manual linear/circular interpolation	Feed axis and direction selection signals	+Jg, -Jg, +Ja, -Ja	G086#0 to #3	○	○	3.5
Manual handle feed	Manual handle feed axis selection signals	HS1A to HS1D	G018#0 to #3	○	○	3.2
		HS2A to HS2D	G018#4 to #7	○	○	
		HS3A to HS3D	G019#0 to #3	—	○	
		HS4A to HS4D	G020#0 to #3	—	○	
	Manual handle feed amount selection signals (incremental feed signals)	MP1, MP2	G019#4, #5	○	○	
		MP21, MP22	G087#0, #1	○	○	
		MP31, MP32	G087#3, #4	○	○	
	MP41, MP42	G087#6, #7	—	○		
Manual handle interrupt	Manual handle interrupt axis selection signals	HS11A to HS11D	G041#0 to #3	○	○	3.3
		HS21A to HS21D	G041#4 to #7	○	○	
		HS31A to HS31D	G042#0 to #3	—	○	
		HS41A to HS41D	G088#4 to #7	—	○	

Function	Signal name	Symbol	Address	T series	M series	Section
Manual Handle Retrace	Check mode handle valid signal	MCHK	G067#3	○	—	5.3.4
	Check mode signal	MMOD	G067#2	○	—	
	Check mode backward movement inhibition signal	MRVM	G067#1	○	—	
	Check mode backward movement signal	MRVMD	F091#0	○	—	
	Inversion inhibition signal	MNCHG	F091#1	○	—	
	Backward movement inhibition signal	MRVSP	F091#2	○	—	
Manual reference position return	Manual reference position return selection signal	ZRN	G043#7	○	○	4.1
	Manual reference position return selection check signal	MREF	F004#5	○	○	
	Reference position return deceleration signal	*DEC1 to *DEC8	X009	○	○	
	Reference position return end signal	ZP1 to ZP8	F094	○	○	
	Reference position establishment signal	ZRF1 to ZRF8	F120	○	○	
Stop position setting for jog feed	Signals for setting the jog feed stop position	JGRD1 to 3	G201#3 to #5	○	—	3.9
Jogfeed/incremental feed	Feed axis and direction selection signals	+J1 to +J8	G100	○	○	3.1
		−J1 to −J8	G102	○	○	
	Manual feedrate override signals	*JV0 to *JV15	G010, G011	○	○	
	Manual rapid traverse selection signals	RT	G019#7	○	○	
CNC ready signal	CNC ready signal	MA	F001#7	○	○	2.2
	Servo ready signal	SA	F000#6	○	○	
Small hole peck drilling cycle (M series)	Overload torque signal	SKIP	X004#7	—	○	11.17
	Small hole peck drilling—in-progress signal	PECK2	F066#5	—	○	
Status output signal	Rapid traversing signal	RPDO	F002#1	○	○	2.8
	Cutting feed signal	CUT	F002#6	○	○	
Serial spindle	Ready signal for serial spindle operation	SRSRDY	F034#7	○	○	9.17
	Ready signals for the first to fourth serial spindle operations	SRSP1R SRSP2R SRSP3R SRSP4R	F034#6 F034#5 F034#4 F034#3	○	○	
Single block	Single block signal	SBK	G046#1	○	○	5.3.3
	Single block check signal	MSBK	F004#3	○	○	
Skip function	Skip signals	SKIP	X004#7	○	○	14.3.1
		SKIPP	G006#6	○	—	

Function	Signal name	Symbol	Address	T series	M series	Section
Start lock/interlock	Start lock signal	STLK	G007#1	○	—	2.5
	Interlock signal	*IT	G008#0	○	○	
	Interlock signal for each axis	*IT1 to *IT8	G130	○	○	
	Manual feed interlock signal for each axis and direction	+MIT1, +MIT2	X004#2, #4	○	—	
	Manual feed interlock signal for each axis and direction	−MIT1, −MIT2	X004#3, #5	○	—	
	Interlock signal for each axis and direction	+MIT1 to +MIT4	G132#0 to #3	—	○	
		−MIT1 to −MIT4	G134#0 to #3	—	○	
	Cutting block start interlock signal	*CSL	G008#1	○	○	
Block start interlock signal	*BSL	G008#3	○	○		
Stored stroke check	Stored stroke limit switching signals in axis direction	+EXL1 to +EXL8	G104	○	○	2.3.2
		−EXL1 to −EXL8	G105	○	○	
	Stored stroke limit change signal	EXLM	G007#6	○	○	2.3.2
	Stroke limit external setting signals	+LM1 to +LM8	G110	—	○	
		−LM1 to −LM8	G112	—	○	
	Stroke limit release signal	RLSOT	G007#7	—	○	
Stroke limit reached signals	+OT1 to +OT8	F124	—	○		
	−OT1 to −OT8	F126	—	○		
Stored stroke limit 2, 3	Stroke limit 3 release signal	RLSOT3	G007#4	○	○	2.3.3
Super CAPi T	Conversational mode start signal	PDT1	G062#4	○	—	
	Restart operation notification signal	PDT2	G062#5	○	—	
Controlled axis detach	Controlled axis detach signals	DTCH1 to DTCH8	G124	○	○	1.2.4
	Controlled axis detach status signals	MDTCH1 to MDTCH8	F110	○	○	
Absolute position detection	Absolute position detector battery voltage zero alarm signal	PBATZ	F172#6	○	○	1.4.2
	Absolute position detector battery voltage low alarm signal	PBATL	F172#7	○	○	
Advanced preview	Advanced preview control mode signal	G08MD	F066#0	○	○	7.1.13
Software operator's panel	Software operator's panel signal (MD1)	MD1O	F073#0	○	○	12.1.15
	Software operator's panel signal (MD2)	MD2O	F073#1	○	○	
	Software operator's panel signal (MD4)	MD4O	F073#2	○	○	
	Software operator's panel signal (ZRN)	ZRNO	F073#4	○	○	
	Software operator's panel signals (+J1 to +J4)	+J1O to +J4O	F081#0, #2, #4, #6	○	○	
	Software operator's panel signals (−J1 to −J4)	−J1O to −J4O	F081#1, #3, #5, #7	○	○	
	Software operator's panel signal (RT)	RTO	F077#6	○	○	

Function	Signal name	Symbol	Address	T series	M series	Section
Software operator's panel	Software operator's panel signal (HS1A)	HS1AO	F077#0	○	○	12.1.15
	Software operator's panel signal (HS1B)	HS1BO	F077#1	○	○	
	Software operator's panel signal (HS1C)	HS1CO	F077#2	○	○	
	Software operator's panel signal (HS1D)	HS1DO	F077#3	○	○	
	Software operator's panel signal (MP1)	MP1O	F076#0	○	○	
	Software operator's panel signal (MP2)	MP2O	F076#1	○	○	
	Software operator's panel signals (*JV0 to *JV15)	*JV00 to *JV15O	F079, F080	○	○	
	Software operator's panel signals (*FV0 to *FV7)	*FV00 to *FV7O	F078	○	○	
	Software operator's panel signal (ROV1)	ROV1O	F076#4	○	○	
	Software operator's panel signal (ROV2)	ROV2O	F076#5	○	○	
	Software operator's panel signal (BDT)	BDTO	F075#2	○	○	
	Software operator's panel signal (SBK)	SBKO	F075#3	○	○	
	Software operator's panel signal (MLK)	MLKO	F075#4	○	○	
	Software operator's panel signal (DRN)	DRNO	F075#5	○	○	
	Software operator's panel signals (KEY1 to KEY4)	KEYO	F075#6	○	○	
	Software operator's panel signal (*SP)	SPO	F075#7	○	○	
Software operator's panel general-purpose switch signals	OUT0 to OUT7	F072	○	○		
Second feedrate override	Second feedrate override signals	*AFV0 to *AVF7	G013	○	○	7.1.7.3
Second figure tool offset	Second figure tool offset signal	G2SLC	G090#7	○	—	10.2
	Second figure tool offset axis select signal	G2Y	G090#6	○	—	
		G2Z	G090#5	○	—	
		G2X	G090#4	○	—	
	Tool offset direction signal	G2RVY	G090#2	○	—	
		G2RVZ	G090#1	○	—	
G2RVX		G090#0	○	—		
Second reference position return/3rd, 4th reference position return	2nd reference position return completion signals	ZP21 to ZP28	F096	○	○	4.5
	3rd reference position return completion signals	ZP31 to ZP38	F098	○	○	
	4th reference position return completion signals	ZP41 to ZP48	F100	○	○	
Multi-stage skip	Skip signals	SKIP2 to SKIP6, SKIP7, SKIP8	X004#2 to #6, #0, #1	○	○	14.3.3

Function	Signal name	Symbol	Address	T series	M series	Section
Canned cycle (M series)/multiple repetitive turning canned cycle (T series)	Chamfering signal	CDZ	G053#7	○	—	11.9
Chuck/tailstock barrier (T series)	Tailstock barrier selection signal	*TSB	G060#7	○	—	2.3.4
Chopping function	Chopping pause signal	*CHLD	G051#7	—	○	1.12
	Chopping start signal	CHPST	G051#6	—	○	
	Chopping speed override signals	*CHP8 to *CHP0	G051#0 to #3	—	○	
	Chopping mode signal	CHPMD	F039#2	—	○	
	Chopping operation signal	CHPCYL	F039#3	—	○	
Butt-type reference position return setting	Torque limit reached signals for butt-type reference position setting	CLRCH1 to CLRCH8	F180	○	○	4.7
DNC operation	DNC operation selection signal	DNCI	G043#5	○	○	5.11
	DNC operation selection confirmation signal	MRMT	F003#4	○	○	
Periodic maintenance screen	Output signal indicating the expiration of the service life managed by periodic maintenance	LIFOVR	F093#0	○	○	12.1.22
Electronics gear box 2 pair	EGB mode confirmation signal	EGBM1 to EGBM8	F208	—	○	1.14.4
Synchronous control	Synchronous control axis selection signals	SYNC1 to SYNC8	G138	○	—	1.8
	Parking signals	PK1 to PK8	G122	○	—	
	Synchronous control under way signals	SYN10 to SYN80	F118	○	—	
Synchronous control	Synchronous control axis selection signals	SYNC1 to SYNC7	G138#0 to #6	●	—	1.9
	Synchronous/composite/superimposed control under way signals	SYN10 to SYN70	F118#0 to #6	●	—	
Dry run	Dry run signal	DRN	G046#7	○	○	5.3.2
	Dry run check signal	MDRN	F002#7	○	○	
Torque limit skip (T series)	Torque limit reached signals	TRQL1 to TRQL8	F114	○	—	14.3.4
Spindle speed control for two-path lathe	Spindle command selection signals	SLSPA, SLSPB	G063#2, #3	●	—	9.4
	Spindle feedback selection signals	SLPCA, SLPCB	G064#2, #3	●	—	
	Spindle command signal	COSP	F064#5	●	—	
Measurement direct input of tool offset value measured B for 2-spindle lathe	Spindle measurement select signal	S2TLS	G040#5	○	—	14.4
	Spindle 1 under measurement signal	S1MES	F062#3	○	—	
	Spindle 2 under measurement signal	S2MES	F062#4	○	—	
Simultaneous input and output operation (M series)	Input and run simultaneous mode selection signal	STRD	G058#5	—	○	13.6
	Output and run simultaneous mode selection signal	STWD	G058#6	—	○	
Thread cutting	Thread cutting signal	THRD	F002#3	○	○	6.4.1

Function	Signal name	Symbol	Address	T series	M series	Section
Tool post interference check (T series, two-path control)	Tool post interference check signal	TICLK	F064#6	●	—	2.3.5
	Tool post interference alarm signal	TIALM	F064#7	●	—	
Rapid traverse override	Rapid traverse override signals	ROV1, ROV2	G014#0, #1	○	○	7.1.7.1
	1% step rapid traverse override selection signals	HROV	G096#7	○	○	
	1% step rapid traverse override signals	*HROV0 to *HROV6	G096#0 to #6	○	○	
Direct operation by PMC/MMC	Direct operation selection signal	DMMC	G042#7	○	○	15.6
PMC axis control/PMC axis speed control function	Control axis selection signals (PMC axis control)	EAX1 to EAX8	G136	○	○	15.1
	Axis control superimposed command signal	EASIP1 to EASIP8	G200	○	○	
	Axis control command signals (PMC axis control)	EC0A to EC6A	G143#0 to #6	○	○	
		EC0B to EC6B	G155#0 to #6	○	○	
		EC0C to EC6C	G167#0 to #6	○	○	
		EC0D to EC6D	G179#0 to #6	○	○	
	Axis control feedrate signals (PMC axis control)	EIF0A to EIF15A	G144, G145	○	○	
		EIF0B to EIF15B	G156, G157	○	○	
		EIF0C to EIF15C	G168, G169	○	○	
		EIF0D to EIF15D	G180, G181	○	○	
	Axis control command read signals (PMC axis control)	EBUFA	G142#7	○	○	
		EBUFB	G154#7	○	○	
		EBUFC	G166#7	○	○	
		EBUFD	G178#7	○	○	
	Axis control data signals (PMC axis control)	EID0A to EID31A	G146 to G149	○	○	
		EID0B to EID31B	G158 to G161	○	○	
		EID0C to EID31C	G170 to G173	○	○	
		EID0D to EID31D	G182 to G185	○	○	
	Axis control command read completion signals (PMC axis control)	EBSYA	F130#7	○	○	
		EBSYB	F133#7	○	○	
		EBSYC	F136#7	○	○	
		EBSYD	F139#7	○	○	
	Reset signals (PMC axis control)	ECLRA	G142#6	○	○	
ECLRB		G154#6	○	○		
ECLRC		G166#6	○	○		
ECLRD		G178#6	○	○		

Function	Signal name	Symbol	Address	T series	M series	Section
PMC axis control/PMC axis speed control function	Axis control temporary stop signals (PMC axis control)	ESTPA	G142#5	○	○	15.1
		ESTPB	G154#5	○	○	
		ESTPC	G166#5	○	○	
		ESTPD	G178#5	○	○	
	Block stop signals (PMC axis control)	ESBKA	G142#3	○	○	
		ESBKB	G154#3	○	○	
		ESBKC	G166#3	○	○	
		ESBKD	G178#3	○	○	
	Block stop disable signals (PMC axis control)	EMSBKA	G143#7	○	○	
		EMSBKB	G155#7	○	○	
		EMSBKC	G167#7	○	○	
		EMSBKD	G179#7	○	○	
	Auxiliary function code signals (PMC axis control)	EM11A to EM48A	F132, F142	○	○	
		EM11B to EM48B	F135, F145	○	○	
		EM11C to EM48C	F138, F148	○	○	
		EM11D to EM48D	F141, F151	○	○	
	Auxiliary function strobe signals (PMC axis control)	EMFA	F131#0	○	○	
		EMFB	F134#0	○	○	
		EMFC	F137#0	○	○	
		EMFD	F140#0	○	○	
	Auxiliary function completion signals (PMC axis control)	EFINA	G142#0	○	○	
		EFINB	G154#0	○	○	
		EFINC	G166#0	○	○	
		EFIND	G178#0	○	○	
	Servo off signals (PMC axis control)	ESOFA	G142#4	○	○	
		ESOFB	G154#4	○	○	
		ESOFC	G166#4	○	○	
		ESOFD	G178#4	○	○	
	Buffering disable signals (PMC axis control)	EMBUFA	G142#2	○	○	
		EMBUFB	G154#2	○	○	
		EMBUFC	G166#2	○	○	
		EMBUFD	G178#2	○	○	
	Accumulated zero check signal	ELCKZA	G142#1	○	○	
		ELCKZB	G154#1	○	○	
		ELCKZC	G166#1	○	○	
		ELCKZD	G178#1	○	○	
	Control axis selection status signals (PMC axis control)	*EAXSL	F129#7	○	○	

Function	Signal name	Symbol	Address	T series	M series	Section
PMC axis control/PMC axis speed control function	In-position signals (PMC axis control)	EINPA	F130#0	○	○	15.1
		EINPB	F133#0	○	○	
		EINPC	F136#0	○	○	
		EINPD	F139#0	○	○	
	Following zero checking signals (PMC axis control)	ECKZA	F130#1	○	○	
		ECKZB	F133#1	○	○	
		ECKZC	F136#1	○	○	
		ECKZD	F139#1	○	○	
	Alarm signals (PMC axis control)	EIALA	F130#2	○	○	
		EIALB	F133#2	○	○	
		EIALC	F136#2	○	○	
		EIALD	F139#2	○	○	
	Axis moving signals (PMC axis control)	EGENA	F130#4	○	○	
		EGENB	F133#4	○	○	
		EGENC	F136#4	○	○	
		EGEND	F139#4	○	○	
	Auxiliary function executing signals (PMC axis control)	EDENA	F130#3	○	○	
		EDENB	F133#3	○	○	
		EDENC	F136#3	○	○	
		EDEND	F139#3	○	○	
	Negative-direction overtravel signals (PMC axis control)	EOTNA	F130#6	○	○	
		EOTNB	F133#6	○	○	
		EOTNC	F136#6	○	○	
		EOTND	F139#6	○	○	
	Positive-direction overtravel signals (PMC axis control)	EOTPA	F130#5	○	○	
		EOTPB	F133#5	○	○	
		EOTPC	F136#5	○	○	
		EOTPD	F139#5	○	○	
Feedrate override signals (PMC axis control)	*FV0E to *FV7E	G151	○	○		
Override cancellation signal (PMC axis control)	OVCE	G150#5	○	○		
Rapid traverse override signals (PMC axis control)	ROV1E, ROV2E	G150#0, #1	○	○		
Dry run signal (PMC axis control)	DRNE	G150#7	○	○		
Manual rapid traverse selection signal (PMC axis control)	RTE	G150#6	○	○		
Override 0% signal (PMC axis control)	EOV0	F129#5	○	○		
Skip signal (PMC axis control)	ESKIP	X004#6	○	○		

Function	Signal name	Symbol	Address	T series	M series	Section
PMC axis control/PMC axis speed control function	Distribution completion signals (PMC axis control)	EADEN1 to EADEN8	F112	○	○	15.1
	Buffer full signals (PMC axis control)	EABUFA	F131#1	○	○	
		EABUFB	F134#1	○	○	
		EABUFC	F137#1	○	○	
		EABUFD	F140#1	○	○	
Controlling signals (PMC axis control)	EACNT1 to EACNT8	F182	○	○		
Spindle output control by the PMC	Spindle motor speed command selection signals	SIND	G033#7	○	○	15.4
		SIND2	G035#7	○	○	
		SIND3	G037#7	○	○	
		SIND4	G273#7	○	○	
	Spindle motor speed command signals	R011 to R121	G032#0 to G033#3	○	○	
		R0112 to R1212	G034#0 to G035#3	○	○	
		R0113 to R1213	G036#0 to G037#3	○	○	
		R0114 to R1214	G272#0 to G273#3	○	○	
	Spindle motor command polarity selection signals	SSIN	G033#6	○	○	
		SSIN2	G035#6	○	○	
		SSIN3	G037#6	○	○	
		SSIN4	G273#6	○	○	
	Spindle motor command polarity command signals	SGN	G033#5	○	○	
		SGN2	G035#5	○	○	
		SGN3	G037#5	○	○	
		SGN4	G273#5	○	○	
Emergency stop	Emergency stop signal	*ESP	G008#4	○	○	2.1
		*ESP	X008#4	○	○	
FANUC SERVO MOTOR β SERIES I/O LINK OPTION MANUAL HANDLE INTERFACE (PERIPHERAL DEVICE CONTROL)	Manual handle feed generator selection signals	IOLBH2	G199#0	○	○	16.1
	Manual handle feed generator selection signals	IOLBH3	G199#1	○	○	
VRDY off alarm ignore signal	All-axis VRDY off alarm ignore signal	IGNVRY	G066#0	○	○	2.9
	Each-axis VRDY off alarm ignore signal	IGVRY1 to IGVRY8	G192	○	○	
Fine Torque Sensing	Torque sensing command signal	FTCMD	G203#0	○	○	12.1.23
	Statistical calculation start signal	FTCAL	G203#1	○	○	
	Store counter clear signal	FTCLR	G203#2	○	○	
Follow-up	Follow-up signal	*FLWU	G007#5	○	○	1.2.7

Function	Signal name	Symbol	Address	T series	M series	Section
Flexible synchronization control	Flexible synchronization control mode select signals	MTA to MTD	G197#0 to #3	—	○	1.15
	Flexible synchronization control mode select signal switching accepted signals	MFSYNA to MFSYND	F197#0 to #3	—	○	
Floating reference position return	Floating reference position return end signals	FRP1 to FRP8	F116	○	○	4.6
Program restart	Program restart signal	SRN	G006#0	○	○	5.7
	Program restart under way signal	SRNMV	F002#4	○	○	
Position switch	Position switch signals	PSW01 to PSW16	F070#0 to F071#7	○	○	1.2.9
Miscellaneous function/2nd auxiliary function	Miscellaneous function code signals	M00 to M31	F010 to F013	○	○	8.1
	Miscellaneous function strobe signal	MF	F007#0	○	○	
	Decode M signals	DM00	F009#7	○	○	
		DM01	F009#6	○	○	
		DM02	F009#5	○	○	
		DM30	F009#4	○	○	
	Spindle function code signals	S00 to S31	F022 to F025	○	○	
	Spindle function strobe signal	SF	F007#2	○	○	
	Tool function code signals	T00 to T31	F026 to F029	○	○	
	Tool function strobe signal	TF	F007#3	○	○	
	2nd auxiliary function code signals	B00 to B31	F030 to F033	○	○	
	2nd auxiliary function strobe signal	BF	F007#4	○	—	
		BF	F007#7	—	○	
	End signal	FIN	G004#3	○	○	
Distribution end signal	DEN	F001#3	○	○		
Auxiliary function lock	Auxiliary function lock signal	AFL	G005#6	○	○	8.2
	Auxiliary function lock check signal	MAFL	F004#4	○	○	
Hobbing function (T series)/Function for hobbing machine (M series)	One-rotation position manual set signal	MSPC	G066#5	○	○	1.13
	One-rotation position setting completed signal	MSPCF	F065#5	○	○	
	Cancel-sync-with-C-axis signal	HOB CAN	G066#2	○	○	
	Sync-with-C-axis signal	HOBSYN	F065#7	○	○	
	Retract signal	RTRCT	G066#4	○	○	
	Retract completed signal	RTRCTF	F065#4	○	○	
Polygonal turning	Polygon synchronization under way signal	PSYN	F063#7	○	—	6.10.1
Machine lock	All-axis machine lock signal	MLK	G044#1	○	○	5.3.1
	Each-axis machine lock signal	MLK1 to MLK8	G108	○	○	
	All-axis machine lock check signal	MMLK	F004#1	○	○	
Waiting M code (two-path control)	No-wait signal	NOWT	G063#1	●	●	8.5
	Waiting signal	WATO	F063#6	●	●	

Function	Signal name	Symbol	Address	T series	M series	Section
Manual absolute on/off	Manual absolute signal	*ABSM	G006#2	○	○	5.4
	Manual absolute check signal	MABSM	F004#2	○	○	
Multi-spindle control (T series)	Spindle selection signals	SWS1	G027#0	○	○	9.10
		SWS2	G027#1	○	○	
		SWS3	G027#2	○	○	
		SWS4	G026#4	○	○	
Multi-spindle control (T series)	Individual spindle stop signals	*SSTP1	G027#3	○	○	9.10
		*SSTP2	G027#4	○	○	
		*SSTP3	G027#5	○	○	
		*SSTP4	G026#6	○	○	
	Gear selection signals (input)	GR21	G029#0	○	○	
		GR31	G029#2	○	○	
		GR41	G031#4	○	○	
	2nd position coder selection signal	PC2SLC	G028#7	○	○	
	3rd position coder selection signal	PC3SLC	G026#0	○	○	
	4th position coder selection signal	PC4SLC	G026#1	○	○	
	Spindle enable signals	ENB2	F038#2	○	○	
ENB3		F038#3	○	○		
ENB4		F039#1	○	○		
Mirror image	Mirror image signals	MI1 to MI8	G106	○	○	1.2.6
	Mirror image check signals	MMI1 to MMI8	F108	○	○	
Memory protection key	Memory protection signals	KEY1 to KEY4	G046#3 to #6	○	○	12.2.3
	Parameter write setting signal	KEYPRM	G046#0	○	○	
Mode selection	Mode selection signals	MD1, MD2, MD4	G043#3 to #2	○	○	2.6
	Manual data input selection check signal	MMDI	F003#3	○	○	
	Automatic operation selection check signal	MMEM	F003#5	○	○	
	Memory edit selection check signal	MEDT	F003#6	○	○	
	Manual handle feed selection check signal	MH	F003#1	○	○	
	Incremental feed selection check signal	MINC	F003#0	○	○	
	Jog feed selection check signal	MJ	F003#2	○	○	
	TEACH IN selection check signal	MTCHIN	F003#7	○	○	
Rigid tapping	Rigid tapping signal	RGTAP	G061#0	○	○	9.11
	Spindle rotation direction signals	RGSP	F065#0	—	○	
		RGSPM	F065#1	—	○	
	Rigid tapping-in-progress signal	RTAP	F076#3	○	○	
	Rigid tapping spindle selection signals	RGTSP1, RGTSP2	G061#4, #5	○	—	

Function	Signal name	Symbol	Address	T series	M series	Section
Retraction for rigid tapping	Rigid tapping retraction start signal	RTNT	G062#6	—	○	5.13
	Rigid tapping retraction completion signal	RTPT	F066#1	—	○	
High-precision contour control by RISC (M series)	HPCC mode signal	MHPCC	F066#6	—	○	7.1.14
	HPCC operation signal	EXHPCC	F066#7	—	○	7.1.19
Reset and rewind	External reset signal	ERS	G008#7	○	○	5.2
	Reset & rewind signal	RRW	G008#6	○	○	
	Resetting signal	RST	F001#1	○	○	
	Rewinding signal	RWD	F000#0	○	○	
Retrace (M series)	Retrace signal	RVS	G007#0	—	○	11.15
	Retrace-in-progress signal	RVSL	F082#2	—	○	
Remote buffer	Input signals for remote buffer	RMTDI0 to RMTDI7	G052	○	○	13.2
	Output signals for remote buffer	RMTDO0 to RMTDO7	F069	○	○	
Interrupt type custom macro	Interrupt signal for custom macro	UINT	G053#3	○	○	11.6.2

A.2.2

List of Signals (In Order of Symbols)

○	: Available
●	: Available only with 2-path control
—	: Unavailable

Group	Symbol	Signal name	Address	T series	M series	Reference item
	*+ED1 to *+ED8	External deceleration signal	G118	○	○	7.1.9
	*+L1 to *+L8	Overtravel signal	G114	○	○	2.3.1
	*-ED1 to *-ED8	External deceleration signal	G120	○	○	7.1.9
	*-L1 to *-L8	Overtravel signal	G116	○	○	2.3.1
	*ABSM	Manual absolute signal	G006#2	○	○	5.4
	*AFV0 to *AFV7	2nd feedrate override signal	G013	○	○	7.1.7.3
	*BECLP	B-axis clamp completion signal	G038#7	—	○	11.11
	*BEUCP	B-axis unclamp completion signal	G038#6	—	○	11.11
	*BSL	Block start interlock signal	G008#3	○	○	2.5
	*CHLD	Chopping hold signal	G051#7	—	○	1.12
	*CHP8 to *CHP0	Chopping feedrate override signals	G051#0 to #3	—	○	1.12
	*CRTOF	Automatic erase CRT screen display cancel signal	G062#1	○	○	12.1.19
	*CSL	Cutting block start interlock signal	G008#1	○	○	2.5
	*DEC1 to *DEC8	Deceleration signal for reference position return	X009	○	○	4.1
	*EAXSL	Control axis selection status signal(PMC axis control)	F129#7	○	○	15.1
*	*ESP	Emergency stop signal	X008#4	○	○	2.1
	*ESP		G008#4	○	○	
	*ESPA	Emergency stop signal (serial spindle)	G071#1	○	○	9.2, 9.15
	*ESPB		G075#1	○	○	
	*ESPC		G205#1	○	○	
	*ESPD		G267#1	○	○	
	*FLWU	Follow-up signal	G007#5	○	○	1.2.7
	*FV0 to *FV7	Feedrate override signal	G012	○	○	7.1.7.2
	*FV0E to *FV7E	Feedrate override signal (PMC axis control)	G151	○	○	15.1
	*FV0O to *FV7O	Software operator's panel signal(*FV0 to *FV7)	F078	○	○	12.1.15
*HROV0 to *HROV6	1% step rapid traverse override signal	G096#0 to #6	○	○	7.1.7.1	
*IT	Interlock signal	G008#0	○	○	2.5	
*IT1 to *IT8	Interlock signal for each axis	G130	○	○	2.5	
*JV0 to *JV15	Manual feedrate override signal	G010,G011	○	○	3.1	
*JV0O to *JV15O	Software operator's panel signal(*JV0 to *JV15)	F079,F080	○	○	12.1.15	
*PLSST	Polygon spindle stop signal	G038#0	○	—	6.10.2	
*SCPF	Spindle clamp completion signal	G028#5	○	—	9.8	
*SP	Feed hold signal	G008#5	○	○	5.1	

Group	Symbol	Signal name	Address	T series	M series	Reference item
*	*SSTP	Spindle stop signal	G029#6	○	○	9.3
	*SSTP1	Individual spindle stop signals	G027#3	○	○	9.10
	*SSTP2		G027#4	○	○	
	*SSTP3		G027#5	○	○	
	*SSTP4		G026#6	○	○	
	*SUCPF	Spindle unclamp completion signal	G028#4	○	—	9.8
	*TLV0 to *TLV9	Tool life count override signal	G049#0 to G050#1	—	○	10.3
*TSB	Tailstock barrier select signal	G060#7	○	—	2.3.4	
+	+EXL1 to +EXL8	Axis direction dependent stored stroke limit switch signal	G104	○	○	2.3.2
	+J1 to +J8	Feed axis and direction selection signal	G100	○	○	3.1
	+J10 to +J40	Software operator's panel signal(+J1 to +J4)	F081#0,#2,#4,#6	○	○	12.1.15
	+Jg, -Jg, +Ja, -Ja	Feed axis and direction selection signals	G086#0 to #3	○	○	3.5
	+LM1 to +LM8	Stroke limit external setting signal	G110	—	○	2.3.2
	+MIT1,+MIT2	Manual feed interlock signal for each axis	X004#2,#4	○	—	2.5
	+MIT1,+MIT2	Tool offset write signal	X004#2,#4	○	—	14.4.2
	+MIT1 to +MIT4	Interlock signal for each axis and direction	G132#0 to #3	—	○	2.5
+OT1 to +OT8	Stroke limit reached signals	F124	—	○	2.3.2	
-	-EXL1 to -EXL8	Axis direction dependent stored stroke limit switch signal	G105	○	○	2.3.2
	-J1 to -J8	Feed axis and direction selection signal	G102	○	○	3.1
	-J10 to -J40	Software operator's panel signal(-J1 to -J4)	F081#1,#3,#5,#7	○	○	12.1.15
	-LM1 to -LM8	Stroke limit external setting signal	G112	—	○	2.3.2
	-MIT1,-MIT2	Manual feed interlock signal for each axis	X004#3,#5	○	—	2.5
	-MIT1,-MIT2	Tool offset write signal	X004#3,#5	○	—	14.4.2
	-MIT1 to -MIT4	Interlock signal for each axis and direction	G134#0 to #3	—	○	2.5
-OT1 to -OT8	Stroke limit reached signals	F126	—	○	2.3.2	
A	ABTQSV	Servo axis abnormal load detected signal	F090#0	○	○	2.10
	ABTSP1	First-spindle abnormal load detected signal	F090#1	○	○	2.10
	ABTSP2	Second-spindle abnormal load detected signal	F090#2	○	○	2.10
	ABTSP3	Third-spindle abnormal load detected signal	F090#3	○	○	9.15
	AFL	Miscellaneous function lock signal	G005#6	○	○	8.2
	AICC	AI contour control, AI nano contour control, or AI advanced control mode signal	F062#0	—	○	7.1.16 7.1.17
	AL	Alarm signal	F001#0	○	○	2.4

Group	Symbol	Signal name	Address	T series	M series	Reference item
A	ALMA	Alarm signal (serial spindle)	F045#0	○	○	9.2, 9.15
	ALMB		F049#0	○	○	
	ALMC		F168#0	○	○	
	ALMD		F266#1	○	○	
	ALNGH	Tool axis direction handle feed mode signal	G023#7	–	○	3.4.1
	AR0 to AR15	Actual spindle speed signal	F040,F041	○	–	9.7
	ARSTA	Alarm reset signal (serial spindle)	G071#0	○	○	9.2, 9.15
	ARSTB		G075#0	○	○	
	ARSTC		G205#0	○	○	
	ARSTD		G267#0	○	○	
B	B00 to B31	2nd auxiliary function code signal	F030 to F033	○	○	8.1
	BAL	Battery alarm signal	F001#2	○	○	2.4
	BCLP	B-axis clamp signal	F061#1	–	○	11.11
	BDT1,BDT2 to BDT9	Optional block skip signal	G044#0,G045	○	○	5.5
	BDTO	Software operator's panel signal(BDT)	F075#2	○	○	12.1.15
	BF	2nd auxiliary function strobe signal	F007#4	○	–	8.1
	BF		F007#7	–	○	
	BFIN	2nd auxiliary function completion signal	G005#4	○	–	8.4
	BFIN		G005#7	–	○	
	BGEACT	Background busy signal	F053#4	○	○	13.8, 13.5
	BGEN	Power Mate background busy signal	G092#4	○	○	13.8
	BGIALM	Power Mate read/write alarm signal	G092#3	○	○	
	BGION	Power Mate read/write inprogress signal	G092#2	○	○	
	BUCLP	B-axis unclamp signal	F061#0	–	○	11.11
C	CDZ	Chamfering signal	G053#7	○	–	11.9
	CFINA	Spindle switch completion signal (serial spindle)	F046#1	○	○	9.2, 9.15
	CFINB		F050#1	○	○	
	CFINC		F169#1	○	○	
	CFIND		F267#1	○	○	
	CHPA	Power line switch signal (serial spindle)	F046#0	○	○	9.2, 9.15
	CHPB		F050#0	○	○	
	CHPC		F169#0	○	○	
	CHPD		F267#0	○	○	
	CHPCYL	Chopping cycle signal	F039#3	–	○	1.12
	CHPMD	Chopping-in-progress signal	F039#2	–	○	
	CHPST	Chopping start signal	G051#6	–	○	
	CLRCH1 to CLRCH8	Torque limit reach signals for butt-type reference position setting	F180	○	○	4.7

Group	Symbol	Signal name	Address	T series	M series	Reference item
C	CON	Cs contour control change signal	G027#7	○	○	9.9
	COSP	Spindle command signal	F064#5	●	—	9.4
	CSF11	Cs-axis coordinate establishment request signal	G274#4	○	○	9.9.2
	CSFO1	Cs-axis coordinate establishment alarm signal	F274#4	○	○	
	CSPENA	Cs-axis coordinate establishment status signal	F048#4	○	○	
	CSS	Constant surface speed signal	F002#2	○	○	9.5
	CTH1A,CTH2A	Clutch/gear signal (serial spindle)	G070#3,#2	○	○	9.2, 9.15
	CTH1B,CTH2B		G074#3,#2	○	○	
	CTH1C,CTH2C		G204#3,#2	○	○	
	CTH1D,CTH2D		G266#3,#2	○	○	
	CUT	Cutting feed signal	F002#6	○	○	2.8
D	DEFMDA	Differential mode command signal (serial spindle)	G072#3	○	○	9.2, 9.15
	DEFMDB		G076#3	○	○	
	DEFMDC		G206#3	○	○	
	DEFMDD		G268#3	○	○	
	DEN	Distribution end signal	F001#3	○	○	8.1
	DM00	Decode M signal	F009#7	○	○	8.1
	DM01		F009#6	○	○	
	DM02		F009#5	○	○	
	DM30		F009#4	○	○	
	DMMC	Direct operation select signal	G042#7	○	○	15.6
	DNCI	DNC operation select signal	G043#5	○	○	5.11
	DRN	Dry run signal	G046#7	○	○	5.3.2
	DRNE	Dry run signal (PMC axis control)	G150#7	○	○	15.1
	DRNO	Software operator's panel signal(DRN)	F075#5	○	○	12.1.15
	DSCNA	Disconnection detection disbale signal (serial spindle)	G073#4	○	○	9.2 9.15
	DSCNB		G077#4	○	○	
	DSCNC		G207#4	○	○	
	DSCND		G269#4	○	○	
	DSP1, DSP2, DSP3	Spindle motor speed detection signals	Y(n+1)#0 to #2	○	○	2.11
	DSV1 to DSV8	Servo motor speed detection signals	Y(n+0)	○	○	
DTCH1 to DTCH8	Controlled axis detach signal	G124	○	○	1.2.4	
E	EA0 to EA6	Address signal for external data input	G002#0 to #6	○	○	15.2
	EABUFA	Buffer full signal (PMC axis control)	F131#1	○	○	15.1
	EABUFB		F134#1	○	○	
	EABUFC		F137#1	○	○	
	EABUFD		F140#1	○	○	
	EACNT1 to EACNT8	Controlling signal (PMC axis control)	F182	○	○	
	EADEN1 to EADEN8	Distribution completion signal(PMC axis control)	F112	○	○	

Group	Symbol	Signal name	Address	T series	M series	Reference item
E	EAX1 to EAX8	Control axis select signal (PMC axis control)	G136	○	○	15.1
	EASIP1 to EASIP8	Axis control superimposed command signal	G200	○	○	
	EBSYA	Axis control command read completion signal (PMC axis control)	F130#7	○	○	15.1
	EBSYB		F133#7	○	○	
	EBSYC		F136#7	○	○	
	EBSYD		F139#7	○	○	
	EBUFA	Axis control command read signal(PMC axis control)	G142#7	○	○	15.1
	EBUFB		G154#7	○	○	
	EBUFC		G166#7	○	○	
	EBUFD		G178#7	○	○	
	EC0A to EC6A	Axis control command signal (PMC axis control)	G143#0 to #6	○	○	15.1
	EC0B to EC6B		G155#0 to #6	○	○	
	EC0C to EC6C		G167#0 to #6	○	○	
	EC0D to EC6D		G179#0 to #6	○	○	
	ECKZA	Following zero checking signal (PMC axis control)	F130#1	○	○	15.1
	ECKZB		F133#1	○	○	
	ECKZC		F136#1	○	○	
	ECKZD		F139#1	○	○	
	ECLRA	Reset signal (PMC axis control)	G142#6	○	○	15.1
	ECLRB		G154#6	○	○	
	ECLRC		G166#6	○	○	
	ECLRD		G178#6	○	○	
	ED0 to ED15	Data signal for external data input	G000,G001	○	○	15.2
	EDENA	Auxiliary function executing signal (PMC axis control)	F130#3	○	○	15.1
	EDENB		F133#3	○	○	
	EDENC		F136#3	○	○	
	EDEND		F139#3	○	○	
EDGN	Slave diagnosis selection signal	F177#7	○	○	13.8	
EF	External operation signal	F008#0	—	○	11.8	
EFD	External operation signal for high-speed interface	F007#1	—	○	8.4	
EFIN	External operation function completion signal	G005#1	—	○		
EFINA	Auxiliary function completion signal (PMC axis control)	G142#0	○	○	15.1	
EFINB		G154#0	○	○		
EFINC		G166#0	○	○		
EFIND		G178#0	○	○		
EGBM1 to EGBM8	EGB mode confirmation signal	F208	—	○	1.14.4	

Group	Symbol	Signal name	Address	T series	M series	Reference item	
E	EGENA	Axis moving signal (PMC axis control)	F130#4	○	○	15.1	
	EGENB		F133#4	○	○		
	EGENC		F136#4	○	○		
	EGEND		F139#4	○	○		
	EIALA	Alarm signal (PMC axis control)	F130#2	○	○		
	EIALB		F133#2	○	○		
	EIALC		F136#2	○	○		
	EIALD		F139#2	○	○		
	EID0A to EID31A	Axis control data signal (PMC axis control)	G146 to G149	○	○		
	EID0B to EID31B		G158 to G161	○	○		
	EID0C to EID31C		G170 to G173	○	○		
	EID0D to EID31D		G182 to G185	○	○		
	EIF0A to EIF15A	Axis control feedrate signal (PMC axis control)	G144,G145	○	○		
	EIF0B to EIF15B		G156,G157	○	○		
	EIF0C to EIF15C		G168,G169	○	○		
	EIF0D to EIF15D		G180,G181	○	○		
	EINPA	In-position signal (PMC axis control)	F130#0	○	○		
	EINPB		F133#0	○	○		
	EINPC		F136#0	○	○		
	EINPD		F139#0	○	○		
	EKC0 to EKC7	Key code signal	G098	○	○		15.5
	EKENB	Key code read completion signal	F053#7	○	○		
	EKSET	key code read signal	G066#7	○	○		
	ELCKZA	Accumulated zero check signal	G142#1	○	○		15.1
ELCKZB	G154#1		○	○			
ELCKZC	G166#1		○	○			
ELCKZD	G178#1		○	○			
EM11A to EM48A	Auxiliary function code signal (PMC axis control)	F132,F142	○	○			
EM11B to EM48B		F135,F145	○	○			
EM11C to EM48C		F138,F148	○	○			
EM11D to EM48D		F141,F151	○	○			
EMBUFA	Buffering disable signal (PMC axis control)	G142#2	○	○			
EMBUFB		G154#2	○	○			
EMBUFC		G166#2	○	○			
EMBUFD		G178#2	○	○			
EMFA	Auxiliary function strobe signal (PMC axis control)	F131#0	○	○			
EMFB		F134#0	○	○			
EMFC		F137#0	○	○			
EMFD		F140#0	○	○			

Group	Symbol	Signal name	Address	T series	M series	Reference item
E	EMSBKA	Block stop disable signal (PMC axis control)	G143#7	○	○	15.1
	EMSBKB		G155#7	○	○	
	EMSBKC		G167#7	○	○	
	EMSBKD		G179#7	○	○	
	ENB	Spindle enable signal	F001#4	○	○	9.3
	ENB2		F038#2	○	—	9.10
	ENB3		F038#3	○	—	
	ENB4		F039#1	○	—	
	ENBKY	External key input mode selection signal	G066#1	○	○	15.5
	EOTNA	Negative-direction overtravel signal (PMC axis control)	F130#6	○	○	15.1
	EOTNB		F133#6	○	○	
	EOTNC		F136#6	○	○	
	EOTND		F139#6	○	○	
	EOTPA	Positive-direction overtravel signal (PMC axis control)	F130#5	○	○	
	EOTPB		F133#5	○	○	
	EOTPC		F136#5	○	○	
	EOTPD		F139#5	○	○	
	EOV0	Override 0% signal (PMC axis control)	F129#5	○	○	
	EPARM	Slave parameter selection signal	F177#6	○	○	13.8
	EPN0 to EPN13	Expanded workpiece number search signals	G024#0 to G025#5	○	○	15.3.2
	EPNS	Expanded workpiece number search start signal	G025#7	○	○	
	EPRG	Slave program selection signal	F177#4	○	○	13.8
	ERDIO	Slave external read start signal	F177#1	○	○	
	EREND	Read completion signal for external data input	F060#0	○	○	15.2
	ERS	External reset signal	G008#7	○	○	5.2
	ESBKA	Block stop signal (PMC axis control)	G142#3	○	○	15.1
	ESBKB		G154#3	○	○	
	ESBKC		G166#3	○	○	
	ESBKD		G178#3	○	○	
	ESEND	Search completion signal for external data input	F060#1	○	○	15.2
	ESKIP	Skip signal (PMC axis control)	X004#6	○	○	15.1
	ESOFA	Servo off signal (PMC axis control)	G142#4	○	○	
	ESOFB		G154#4	○	○	
ESOFC	G166#4		○	○		
ESOFD	G178#4		○	○		
ESRSYC	Simple spindle synchronous control signal	G064#6	○	○	9.16	
ESTB	Read signal for external data input	G002#7	○	○	15.2	
ESCAN	Search cancel signal for external data input	F060#2	○	○		

Group	Symbol	Signal name	Address	T series	M series	Reference item
E	ESTPA	Axis control temporary stop signal (PMC axis control)	G142#5	○	○	15.1
	ESTPB		G154#5	○	○	
	ESTPC		G166#5	○	○	
	ESTPD		G178#5	○	○	
	ESTPIO	Slave read/write stop signal	F177#2	○	○	13.8
	EVAR	Slave macro variable selection signal	F177#5	○	○	
	EWGIO	Slave external write start signal	F177#3	○	○	
	EXHPCC	HPCC operation signal	F066#7	—	○	7.1.14
	EXLM	Stored stroke limit select signal	G007#6	○	○	2.3.2
	EXOFA	Motor activation off status signal (serial spindle)	F047#4	○	○	9.2 9.15
	EXOFB		F051#4	○	○	
	EXOFC		F170#4	○	○	
	EXOFD		F268#4	○	○	
	EXRD	External read start signal	G058#1	○	○	13.8, 13.5
	EXSTP	External read/punch stop signal	G058#2	○	○	
EXWT	External punch start signal	G058#3	○	○		
F	F1D	F1 – digit feed select signal	G016#7	—	○	7.1.5
	FIN	Completion signal	G004#3	○	○	8.1
	FRP1 to FRP8	Floating reference position return end signal	F116	○	○	4.6
	FSCSL	Cs contour control change completion signal	F044#1	○	○	9.9
	FSPPH	Spindle phase synchronous control completion signal	F044#3	○	○	9.12
	FSPSY	Spindle synchronous speed control completion signal	F044#2	○	○	
	FTCAL	Statistical calculation start signal	G203#1	○	○	12.1.23
	FTCLR	Store counter clear signal	G203#2	○	○	
	FTCMD	Torque sensing command signal	G203#0	○	○	
G	G08MD	Advanced preview control mode signal	F066#0	—	○	7.1.13
	G2RVX	Tool offset direction signal	G090#0	○	—	10.2
	G2RVY		G090#2	○	—	
	G2RVZ		G090#1	○	—	
	G2SLC	Second figure tool offset signal	G090#7	○	—	
	G2X	Second figure tool offset axis select signal	G090#4	○	—	
	G2Y		G090#6	○	—	
	G2Z		G090#5	○	—	
	GOQSM	Tool offset value write mode select signal	G039#7	○	—	14.4.2
	GR1,GR2	Gear selection signal (input)	G028#1,#2	○	○	9.3
	GR10,GR20,GR30	Gear selection signal (output)	F034#0 to #2	—	○	

Group	Symbol	Signal name	Address	T series	M series	Reference item
G	GR21	Gear selection signal (input)	G029#0	○	○	9.10
	GR31		G029#2	○	○	
	GR41		G031#4	○	○	
H	HCAB2	Hard copy stop request acceptance flag	F061#2	○	○	13.9
	HCABT	Hard copy stop request signal	G067#6	○	○	
	HCEXE	Hard copy in-progress signal	F061#3	○	○	
	HCREQ	Hard copy request signal	G067#7	○	○	
	HCSKP1 to HCSKP4	Skip signals for high-speed cycle machining	G065#4 to 7	○	○	11.19
	HDO0 to HDO7	High-speed skip status signal	F122	○	○	14.3.2
	HEAD	Path selection signal (Tool post selection signal)	G063#0	●	●	2.7
	HOBCAN	Cancel-sync-with-C-axis signal	G066#2	○	○	1.13
	HOBSYN	Sync-with-C-axis signal	F065#7	○	○	
	HROV	1% step rapid traverse override select signal	G096#7	○	○	7.1.7.1
	HS1A to HS1D	Manual handle feed axis selection signal	G018#0 to #3	○	○	3.2
	HS1AO	Software operator's panel signal(HS1A)	F077#0	○	○	12.1.15
	HS1BO	Software operator's panel signal(HS1B)	F077#1	○	○	
	HS1CO	Software operator's panel signal(HS1C)	F077#2	○	○	
	HS1DO	Software operator's panel signal(HS1D)	F077#3	○	○	
	HS1IA to HS1ID	Manual handle interruption axis select signal	G041#0 to #3	○	○	3.3
	HS2A to HS2D	Manual handle feed axis selection signal	G018#4 to #7	○	○	3.2
	HS2IA to HS2ID	Manual handle interruption axis select signal	G041#4 to #7	○	○	3.3
	HS3A to HS3D	Manual handle feed axis selection signal	G019#0 to #3	○	○	3.2
	HS3IA to HS3ID	Manual handle interruption axis select signal	G042#0 to #3	○	○	3.3
HS4A to HS4D	Manual handle feed axis select signals	G020#0 to #3	–	○	3.2	
HS4IA to HS4ID	Manual handle feed axis select signals	G088#4 to #7	–	○	3.3	
I	IGNVRY	All-axis VRDY OFF alarm ignore signal	G066#0	○	○	2.9
	IGVRY1 to IGVRY8	Each-axis VRDY OFF alarm ignore signal	G192	○	○	
	INCH	Inch input signal	F002#0	○	○	11.4
	INCMDA	Incremental command external setting type orientation signal (serial spindle)	G072#5	○	○	9.2, 9.15
	INCMDB		G076#5	○	○	
	INCMDC		G206#5	○	○	
	INCMDD		G268#5	○	○	
	INCSTA	Incremental method orientation signal (serial spindle)	F047#1	○	○	
	INCSTB		F051#1	○	○	
	INCSTC		F170#1	○	○	
	INCSTD		F268#1	○	○	

Group	Symbol	Signal name	Address	T series	M series	Reference item
I	INDXA	Orientation stop position change signal (serial spindle)	G072#0	○	○	9.2, 9.15
	INDXB		G076#0	○	○	
	INDXC		G206#0	○	○	
	INDXD		G268#0	○	○	
	INHKY	Key input disable signal	F053#0	○	○	15.5
	INP1 to INP8	In-position signal	F104	○	○	7.2.6.1
	INTGA	Signal for controlling velocity integration (serial spindle)	G071#5	○	○	9.2, 9.15
	INTGB		G075#5	○	○	
	INTGC		G205#5	○	○	
	INTGD		G267#5	○	○	
	IOLACK	I/O Link confirmation signal	G092#0	○	○	13.8
	IOLBH2	Manual handle feed generator selection signals	G199#0	○	○	16.1
	IOLBH3		G199#1	○	○	
	IOLNK	Slave I/O Link selection signal	F177#0	○	○	13.8
	IOLS	I/O Link specification signal	G092#1	○	○	13.8
ITCD	Rotation area interference check disable signal	G292#7	○	○	2.3.7	
IUDD1 to IUDD8	Abnormal load detection ignore signal	G125	○	○	2.10	
J	JGRD1 to 3	Signals for setting the jog feed stop position	G201#3 to #5	○	—	3.9
K	KEY1 to KEY4	Memory protect signal	G046#3 to #6	○	○	12.2.3
	KEYO	Software operator's panel signal(KEY1 to KEY4)	F075#6	○	○	12.1.15
	KEYPRM	Parameter write setting signal	G046#0	○	○	12.2.3
L	LDT1A	Load detection signal 1 (serial spindle)	F045#4	○	○	9.2, 9.15
	LDT1B		F049#4	○	○	
	LDT1C		F168#4	○	○	
	LDT1D		F266#4	○	○	
	LDT2A	Load detection signal 2 (serial spindle)	F045#5	○	○	
	LDT2B		F049#5	○	○	
	LDT2C		F168#5	○	○	
	LDT2D		F266#5	○	○	
	LIFOVR	Output signal indicating the expiration of the service life managed by periodic maintenance	F093#0	○	○	
M	M00 to M31	Miscellaneous function code signal	F010 to F013	○	○	8.1
	M200 to M215	2nd M function code signal	F014 to F015	○	○	8.3
	M300 to M315	3rd M function code signal	F016 to F017	○	○	8.3
	MA	CNC ready signal	F001#7	○	○	2.2
	MABSM	Manual absolute check signal	F004#2	○	○	5.4
	MAFL	Miscellaneous function lock check signal	F004#4	○	○	8.2
	MBDT1,MBDT2 to MBDT9	Optional block skip check signal	F004#0,F005	○	○	5.5

Group	Symbol	Signal name	Address	T series	M series	Reference item
M	MCFNA	Power line switch completion signal (serial spindle)	G071#3	○	○	9.2, 9.15
	MCFNB		G075#3	○	○	
	MCFNC		G205#3	○	○	
	MCFND		G267#3	○	○	
	MCHK	Check mode handle valid signal	G067#3	○	—	5.3.4
	MD1,MD2,MD4	Mode selection signal	G043#0 to #2	○	○	2.6
	MD1O	Software operator's panel signal(MD1)	F073#0	○	○	12.1.15
	MD2O	Software operator's panel signal(MD2)	F073#1	○	○	
	MD4O	Software operator's panel signal(MD4)	F073#2	○	○	
	MDRN	Dry run check signal	F002#7	○	○	5.3.2
	MDTCH1 to MDTCH8	Controlled axis detach status signal	F110	○	○	1.2.4
	MEDT	Memory edit select check signal	F003#6	○	○	2.6
	MF	Auxiliary function strobe signal	F007#0	○	○	8.1
	MF2	2nd M function strobe signal	F008#4	○	○	8.3
	MF3	3rd M function strobe signal	F008#5	○	○	
	MFIN	Auxiliary function completion signal	G005#0	○	○	8.4
	MFIN2	2nd M function completion signal	G004#4	○	○	
	MFIN3	3rd M function completion signal	G004#5	○	○	
	MFNHGA	Main spindle MCC status signal while changing spindles signal (serial spindle)	G072#6	○	○	9.2, 9.15
	MFNHGB		G076#6	○	○	
	MFNHGC		G206#6	○	○	
	MFNHGD		G268#6	○	○	
	MFSYNA to MFSYND	Flexible synchronization control mode select signal switching accepted signals	F197#0 to #3	—	○	1.15
	MH	Manual handle feed select check signal	F003#1	○	○	2.6
	MHPCC	HPCC mode signal	F066#6	—	○	7.1.14 7.1.19
	MI1 to MI8	Mirror image signal	G106	○	○	1.2.6
	MINC	Incremental feed select check signal	F003#0	○	○	2.6
	MINP	External program input start signal	G058#0	○	○	13.7
	MIX1 to MIX7	Composite control axis selection signals	G128#0 to #6	●	—	1.9
	MJ	JOG feed select check signal	F003#2	○	○	2.6
	MLK	All-axis machine lock signal	G044#1	○	○	5.3.1
	MLK1 to MLK8	Each-axis machine lock signal	G108	○	○	
	MLKO	Software operator's panel signal(MLK)	F075#4	○	○	12.1.15
	MMDI	Manual data input select check signal	F003#3	○	○	2.6
MMEM	Automatic operation select check signal	F003#5	○	○		
MMI1 to MMI8	Mirror image check signal	F108	○	○	1.2.6	
MMLK	All-axis machine lock check signal	F004#1	○	○	5.3.1	

Group	Symbol	Signal name	Address	T series	M series	Reference item
M	MMOD	Check mode signal	G067#2	○	—	5.3.4
	MNCHG	Inversion inhibition signal	F091#1	○	—	
	MORA1A	Signal for completion of spindle orientation with a magnetic sensor (serial spindle)	F046#6	○	○	9.2, 9.15
	MORA1B		F050#6	○	○	
	MORA1C		F169#6	○	○	
	MORA1D		F267#6	○	○	
	MORA2A	Signal for approximate spindle orientation with a magnetic sensor (serial spindle)	F046#7	○	○	
	MORA2B		F050#7	○	○	
	MORA2C		F169#7	○	○	
	MORA2D		F267#7	○	○	
	MORCMA	Command for spindle orientation with a magnetic sensor (serial spindle)	G073#0	○	○	
	MORCMB		G077#0	○	○	
	MORCMC		G207#0	○	○	
	MORCMD		G269#0	○	○	
	MP1,MP2	Manual handle feed amount selection signal (incremental feed signal)	G019#4,#5	○	○	3.2
	MP1O	Software operator's panel signal(MP1)	F076#0	○	○	12.1.15
	MP2O	Software operator's panel signal(MP2)	F076#1	○	○	
	MP21, MP22	Manual handle feed travel distance select signals (incremental feed signals)	G087#0,#1	○	○	3.2
	MP31, MP32	Manual handle feed travel distance select signals (incremental feed signals)	G087#3,#4	○	○	
	MP41, MP42	Manual handle feed travel distance select signals (incremental feed signals)	G087#6,#7	—	○	
	MPOFA	Motor power stop signal (serial spindle)	G073#2	○	○	9.2, 9.15
	MPOFB		G077#2	○	○	
	MPOFC		G207#2	○	○	
	MPOFD		G269#2	○	○	
	MRDYA	Machine ready signal (serial spindle)	G070#7	○	○	
	MRDYB		G074#7	○	○	
	MRDYC		G204#7	○	○	
	MRDYD		G266#7	○	○	
	MREF	Manual reference position return selection check signal	F004#5	○	○	4.1
	MRMT	DNC operation select check signal	F003#4	○	○	5.11
MRVM	Check mode backward movement inhibition signal	G067#1	○	—	5.3.4	
MRVMD	Check mode backward movement signal	F091#0	○	—		
MRVSP	Backward movement inhibition signal	F091#2	○	—		
MSBK	Single block check signal	F004#3	○	○	5.3.3	
MSDFON	Motor speed detection function enable signal	G016#0	○	○	2.11	

Group	Symbol	Signal name	Address	T series	M series	Reference item
M	MSPC	One-rotation position manual set signal	G066#5	○	○	1.13
	MSPCF	One-rotation position setting completed signal	F065#5	○	○	
	MTA to MTD	Flexible synchronization control mode select signals	G197#0 to #3	—	○	1.15
	MTCHIN	TEACH IN select check signal	F003#7	○	○	2.6
	MV1 to MV8	Axis moving signal	F102	○	○	1.2.5
	MVD1 to MVD8	Axis moving direction signal	F106	○	○	
N	NOWT	No-wait signal	G063#1	●	●	8.5
	NOZAGC	Perpendicular/angular axis control disable signal	G063#5	○	○	1.11
	NPOS1 to NPOS8	Position display neglect signal	G198	○	○	12.1.10
	NRROA	Short-distant movement command while changing the orientation stop position signal (serial spindle)	G072#2	○	○	9.2, 9.15
	NRROB		G076#2	○	○	
	NRROC		G206#2	○	○	
	NRROD		G268#2	○	○	
O	OFN0 to OFN5, OFN6	Tool offset number select signal	G039#0 to #5, G040#0	○	—	14.4.2
	OP	Automatic operation signal	F000#7	○	○	5.1
	ORARA	Orientation completion signal (serial spindle)	F045#7	○	○	9.2, 9.15
	ORARB		F049#7	○	○	
	ORARC		F168#7	○	○	
	ORARD		F266#7	○	○	
	ORCMA	Orientation command signal (serial spindle)	G070#6	○	○	9.2, 9.15
	ORCMB		G074#6	○	○	
	ORCMC		G204#6	○	○	
	ORCMD		G266#6	○	○	
	OUT0 to OUT7	Software operator's panel general-purpose switch signal	F072	○	○	12.1.15
	OVC	Override cancel signal	G006#4	○	○	7.1.7.4
	OVCE	Override cancellation signal (PMC axis control)	G150#5	○	○	15.1
	OVLS1 to OVLS7	Superimposed control axis selection signals	G190#0 to #6	●	—	1.9
	OVRA	Analog override command signal (serial spindle)	G072#4	○	○	9.2, 9.15
	OVRB		G076#4	○	○	
	OVRC		G206#4	○	○	
OVRD	G268#4		○	○		
P	PBATL	Absolute position detector battery voltage low alarm signal	F172#7	○	○	1.4.2
	PBATZ	Absolute position detector battery voltage zero alarm signal	F172#6	○	○	

Group	Symbol	Signal name	Address	T series	M series	Reference item
P	PC1DEA	Signal indicating the status of the detected one-rotation position coder signal (serial spindle)	F047#0	○	○	9.2, 9.15
	PC1DEB		F051#0	○	○	
	PC1DEC		F170#0	○	○	
	PC1DED		F268#0	○	○	
	PC2SLC	2nd position coder selection signal	G028#7	○	—	9.10
	PC3SLC	3rd position coder selection signal	G026#0	○	○	
	PC4SLC	4th position coder selection signal	G026#1	○	○	
	PDT1	Conversation mode selection signal	G062#4	○	—	
	PDT2	Restart operation notification signal	G062#5	○	—	
	PECK2	Small-diameter peck drilling in progress signal	F066#5	—	○	11.17
	PK1 to PK8	Parking signals	G122	○	—	1.8
	PK1 to PK7	Parking signals	G122#0 to #6	●	—	1.9
	PKESS1	First spindle synchronous control signal	G122#6 (G031#6)	○	○	9.16
	PKESS2	Second spindle synchronous control signal	G122#7 (G031#7)	○	○	
	PN1,PN2,PN4,PN8,PN16	Workpiece number search signal	G009#0 to 4	○	○	15.3
	PORA2A	Signal for approximate spindle orientation with a position coder (serial spindle)	F046#5	○	○	9.2, 9.15
	PORA2B		F050#5	○	○	
	PORA2C		F169#5	○	○	
	PORA2D		F267#5	○	○	
	PRC	Position record signal	G040#6	○	—	14.4.1
	PRGDPL	program screen display mode signal	F053#1	○	○	15.5
	PRTSF	Target parts count reached signal	F062#7	○	○	12.1.11
	PSAR	Spindle polygon speed arrival signal	F063#2	○	—	6.10.2
	PSE1	Master axis not arrival signal	F063#0	○	—	
PSE2	Polygon synchronous axis not arrival signal	F063#1	○	—		
PSW01 to PSW16	Position switch signal	F070#0 to F071#7	○	○	1.2.9	
PSYN	Polygon synchronization under way signal	F063#7	○	—	6.10.1	
R	R011 to R121	Spindle motor speed command signal	G032#0 to G033#3	○	○	15.4
	R0112 to R1212		G034#0 to G035#3	○	○	
	R0113 to R1213		G036#0 to G037#3	○	○	
	R0114 to R1214		G272#0 to G273#3	○	○	
	R010 to R120	S12-bit code signal	F036#0 to F037#3	○	○	9.3

Group	Symbol	Signal name	Address	T series	M series	Reference item
R	RCFNA	Output switch completion signal (serial spindle)	F046#3	○	○	9.2, 9.15
	RCFNB		F050#3	○	○	
	RCFNC		F169#3	○	○	
	RCFND		F1267#3	○	○	
	RCHA	Power line status check signal (serial spindle)	G071#7	○	○	
	RCHB		G075#7	○	○	
	RCHC		G205#7	○	○	
	RCHD		G267#7	○	○	
	RCHHGA	High-output MCC status signal while a magnetic sensor (serial spindle)	G072#7	○	○	
	RCHHGB		G076#7	○	○	
	RCHHGC		G206#7	○	○	
	RCHHGD		G268#7	○	○	
	RCHPA	Output switch signal (serial spindle)	F046#2	○	○	
	RCHPB		F050#2	○	○	
	RCHPC		F169#2	○	○	
	RCHPD		F267#2	○	○	
	RGHTH	Tool axis perpendicular direction handle feed mode signal	G023#6	—	○	3.4.2
	RGSPM	Spindle rotation direction signal	F065#1	—	○	9.11
	RGSPP		F065#0	—	○	
	RGTAP	Rigid tapping signal	G061#0	○	○	
	RGTSP1,RGTSP2	Rigid tapping spindle selection signal	G061#4,#5	○	—	
	RLSOT	Stroke check release signal	G007#7	—	○	2.3.2
	RLSOT3	Stroke check 3 release signal	G007#4	○	○	2.3.3
	RMTDI0 to RMTDI7	Input signal for remote buffer	G052	○	○	13.2
	RMTDO0 to RMTDO7	Output signal for remote buffer	F069	○	○	
	ROTAA	Rotation direction command while changing the orientation stop position signal (serial spindle)	G072#1	○	○	9.2, 9.15
	ROTAB		G076#1	○	○	
	ROTAC		G206#1	○	○	
	ROTAD		G268#1	○	○	
	ROV1,ROV2	Rapid traverse override signal	G014#0,#1	○	○	7.1.7.1
	ROV1E,ROV2E	Rapid traverse override signal(PMC axis control)	G150#0,#1	○	○	15.1
	ROV1O	Software operator's panel signal(ROV1)	F076#4	○	○	12.1.15
ROV2O	Software operator's panel signal(ROV2)	F076#5	○	○		
RPALM	Read/punch alarm signal	F053#3	○	○	13.8, 13.5	
RPBSY	Read/punch in-progress signal	F053#2	○	○		
RPDO	Rapid traversing signal	F002#1	○	○	2.8	
RRW	Reset&rewind signal	G008#6	○	○	5.2	

Group	Symbol	Signal name	Address	T series	M series	Reference item
R	RSLA	Output switch request signal (serial spindle)	G071#6	○	○	9.2, 9.15
	RSLB		G075#6	○	○	
	RSLC		G205#6	○	○	
	RSLD		G267#6	○	○	
	RST	Reset signal	F001#1	○	○	5.2
	RT	Manual rapid traverse selection signal	G019#7	○	○	3.1
	RTAP	Rigid tapping in-progress signal	F076#3	○	○	9.11
	RTE	Manual rapid traverse selection signal (PMC axis control)	G150#6	○	○	15.1
	RTO	Software operator's panel signal(RT)	F077#6	○	○	12.1.15
	RTNT	Rigid tapping retraction start signal	G062#6	—	○	5.13
	RTPT	Rigid tapping retraction completion signal	F066#1	—	○	
	RTRCT	Retract signal	G066#4	○	○	1.13 1.3 1.14.1 1.14.2 1.14.4 1.16
	RTRCTF	Retract completion signal	F065#4	○	○	
	RVS	Retrace signal	G007#0	—	○	11.15
	RVSL	Retrace-in-progress signal	F082#2	—	○	
RWD	Rewinding signal	F000#0	○	○	5.2	
S	S00 to S31	Spindle speed code signal	F022 to F025	○	○	8.1
	S1MES	Spindle 1 under measurement signal	F062#3	○	—	14.4
	S2MES	Spindle 2 under measurement signal	F062#4	○	—	
	S2TLS	Spindle measurement select signal	G040#5	○	—	
	SA	Servo ready signal	F000#6	○	○	2.2
	SAR	Spindle speed arrival signal	G029#4	○	○	9.3
	SARA	Speed arrival signal (serial spindle)	F045#3	○	○	9.2, 9.15
	SARB		F049#3	○	○	
	SARC		F168#3	○	○	
	SARD		F266#3	○	○	
	SBK	Single block signal	G046#1	○	○	5.3.3
	SBKO	Software operator's panel signal(SBK)	F075#3	○	○	12.1.15
	SCLP	Spindle clamp signal	F038#0	○	—	9.8
	SDTA	Speed detection signal (serial spindle)	F045#2	○	○	9.2, 9.15
	SDTB		F049#2	○	○	
	SDTC		F168#2	○	○	
	SDTD		F266#2	○	○	
	SF	Spindle speed strobe signal	F007#2	○	○	8.1
SFIN	Spindle function completion signal	G005#2	○	○	8.4	

Group	Symbol	Signal name	Address	T series	M series	Reference item
S	SFRA	CW command signal (serial spindle)	G070#5	○	○	9.2, 9.15
	SFRB		G074#5	○	○	
	SFRC		G204#5	○	○	
	SFRD		G266#5	○	○	
	SGN	Spindle motor command polarity select signal	G033#5	○	○	15.4
	SGN2		G035#5	○	○	
	SGN3		G037#5	○	○	
	SGN4		G273#5	○	○	
	SHA00 to SHA11	Spindle orientation external stop position command signal	G078#0 to G079#3	○	○	9.13
	SHB00 to SHB11		G080#0 to G081#3	○	○	
	SHC00 to SHC11		G208#0 to G209#3	○	○	9.15
	SHD00 to SHD11		G270#0 to G271#3	○	○	
	SIND	Spindle motor speed command select signal	G033#7	○	○	15.4
	SIND2		G035#7	○	○	
	SIND3		G037#7	○	○	
	SIND4		G273#7	○	○	
	SKIP	Skip signal	X004#7	○	○	14.3.1
		Overload torque signal	X004#7	—	○	11.17
	SKIP2 to SKIP6, SKIP7, SKIP8	Skip signal	X004#2 to #6, #0, #1	○	○	14.3.3
	SKIPP	Skip signal	G006#6	○	—	14.3.1
	SLPCA, SLPCB	Spindle return select signal	G064#2, #3	●	—	9.4
	SLSPA, SLSPB	Spindle command select signal	G063#2, #3	●	—	
	SLVA	Slave operation command signal (serial spindle)	G073#1	○	○	9.2, 9.15
	SLVB		G077#1	○	○	
	SLVC		G207#1	○	○	
	SLVD		G269#1	○	○	
	SLVSA	Slave operation status signal (serial spindle)	F046#4	○	○	9.2, 9.15
	SLVSB		F050#4	○	○	
	SLVSC		F169#4	○	○	
	SLVSD		F267#4	○	○	
SMZ	Error detect signal	G053#6	○	—	7.2.6.3	
SOCNA	Soft start/stop cancel signal (serial spindle)	G071#4	○	○	9.2, 9.15	
SOCNB		G075#4	○	○		
SOCNC		G205#4	○	○		
SOCND		G267#4	○	○		

Group	Symbol	Signal name	Address	T series	M series	Reference item
S	SOR	Spindle orientation signal	G029#5	○	○	9.3
	SOV0 to SOV7	Spindle speed override signal	G030	○	○	
	SPAL	Spindle fluctuation detection alarm signal	F035#0	○	○	9.6
	SPL	Feed hold lamp signal	F000#4	○	○	5.1
	SPO	Software operator's panel signal(*SP)	F075#7	○	○	12.1.15
	SPPHS	Spindle phase synchronous control signal	G038#3	○	○	9.12
	SPSLA	Spindle select signal (serial spindle)	G071#2	○	○	9.2, 9.15
	SPSLB		G075#2	○	○	
	SPSLC		G205#2	○	○	
	SPSLD		G267#2	○	○	
	SPSTP	Spindle stop complete signal	G028#6	○	—	9.8
	SPSYC	Spindle synchronous control signal	G038#2	○	○	9.12
	SPWRN1 to 9	Spindle warning detailed signals	F264#0 to #7, F265#0	○	○	18.4
	SRLNI0 to SRLNI3	Group number specification signals	G091#0 to #3	○	○	13.8
	SRLNO0 to SRLNO3	Group number output signals	F178#0 to #3	○	○	
	SRN	Program restart signal	G006#0	○	○	5.7
	SRNMV	Program restart under way signal	F002#4	○	○	
	SRSRDY	Ready signal for serial spindle operation	F034#7	○	○	9.17
	SRSP1R to SRSP4R	Ready signals for the first to fourth serial spindle operations	F034#6 to #3	○	○	
	SRVA	CCW command signal (serial spindle)	G070#4	○	○	9.2, 9.15
	SRVB		G074#4	○	○	
	SRVC		G204#4	○	○	
	SRVD		G266#4	○	○	
	SSIN	Spindle motor command polarity select signal	G033#6	○	○	15.4
	SSIN2		G035#6	○	○	
	SSIN3		G037#6	○	○	
	SSIN4		G273#6	○	○	
	SSTA	Speed zero signal (serial spindle)	F045#1	○	○	9.2, 9.15
	SSTB		F049#1	○	○	
	SSTC		F168#1	○	○	
	SSTD		F266#1	○	○	
	ST	Cycle start lamp signal	G007#2	○	○	5.1
	STL	Cycle start signal	F000#5	○	○	
	STLK	Start lock signal	G007#1	○	—	2.5
STRD	Input and run simultaneous mode select signal	G058#5	—	○	13.6	
STWD	Output and run simultaneous mode select signal	G058#6	—	○		
SUCLP	Spindle unclamp signal	F038#1	○	—	9.8	

Group	Symbol	Signal name	Address	T series	M series	Reference item
S	SVF1 to SVF8	Servo off signal	G126	○	○	1.2.8
	SVWRN1 to 4	Servo warning detail signals	F093#4 to #7	○	○	18.3
	SWS1	Spindle selection signals	G027#0	○	○	9.10
	SWS2		G027#1	○	○	
	SWS3		G027#2	○	○	
	SWS4		G026#3	○	○	
	SYCAL	Phase error monitor signal	F044#4	○	○	9.16
	SYN1O to SYN8O	Synchronous control under way signals	F118	○	—	1.8
	SYN1O to SYN7O	Synchronous/composite/superimposed control under way signals	F118#0 to #6	●	—	1.9
	SYNC1 to SYNC8	Simple synchronous axis select signal	G138	○	○	1.6
	SYNC to SYNC8	Synchronous control axis selection signals	G138	○	—	1.8
	SYNC to SYNC7		G138#0 to #6	●	—	1.9
	SYNCJ1 to SYNCJ8	Simple synchronous manual feed axis select signal	G140	—	○	1.6
SYNMOD	EGB mode signal	F065#6	—	○	1.13 1.14	
T	T00 to T31	Tool function code signal	F026 to F029	○	○	8.1
	TAP	Tapping signal	F001#5	○	○	11.7
	TDF1 to 8	Trouble forecast signals	F298#0 to #7	○	○	18.1.6
	TF	Tool function strobe signal	F007#3	○	○	8.1
	TFIN	Tool function completion signal	G005#3	○	○	8.4
	THRD	Thread cutting signal	F002#3	○	○	6.4.1
	TIALM	Tool post interference alarm signal	F064#7	●	—	2.3.5
	TICLK	Tool post interference check signal	F064#6	●	—	
	TL01 to TL64	Tool group number select signal	G047#0 to #6	○	—	10.3
	TL01 to TL256		G047#0 to G048#0	—	○	
	TLCH	Tool change signal	F064#0	○	○	
	TLCHB	Tool life arrival notice signal	F064#3	—	○	10.3.3
	TLCHI	Individual tool change signal	F064#2	—	○	10.3
	TLMA	Torque limit signal (serial spindle)	F045#6	○	○	9.2, 9.15
	TLMB		F049#6	○	○	
	TLMC		F168#6	○	○	
	TLMD		F266#6	○	○	
	TLMHA	Torque limit command HIGH signal (serial spindle)	G070#1	○	○	
TLMHB	G074#1		○	○		
TLMHC	G204#1		○	○		
TLMHD	G266#1		○	○		

Group	Symbol	Signal name	Address	T series	M series	Reference item
T	TLMLA	Torque limit command LOW signal (serial spindle)	G070#0	○	○	9.2, 9.15
	TLMLB		G074#0	○	○	
	TLMLC		G204#0	○	○	
	TLMLD		G266#0	○	○	
	TLNW	New tool select signal	F064#1	○	○	10.3
	TLRST	Tool change reset signal	G048#7	○	○	
	TLRSTI	Individual tool change reset signal	G048#6	—	○	
	TLSKP	Tool skip signal	G048#5	○	○	
	TMRON	General-purpose integrating meter start signal	G053#0	○	○	12.1.11
	TRACT	Tool retraction mode signal	F092#3	○	○	5.8
	TRESC	Tool retraction signal	G059#0	○	○	
	TRQL1 to TRQL8	Torque limit reached signal	F114	○	○	14.3.4
	TRRTN	Tool return signal	G059#1	○	○	5.8
	TRSPS	Tool return completion signal	F092#5	○	○	
U	UI000 to UI015	Input signal for custom macro	G054,G055	○	○	11.6.1
	UI016 to UI031 UI100 to UI131 UI200 to UI231 UI300 to UI331	Input signals for custom macro (Extended signals)	G056,G057 G276 to G279 G280 to G283 G284 to G287	○	○	11.6.1
	UINT	Interrupt signal for custom macro	G053#3	○	○	11.6.2
	UO000 to UO015	Output signal for custom macro	F054,F055	○	○	11.6.1
	UO100 to UO131		F056 to F059	○	○	
	UO016 to UO031 UO200 to UO231 UO300 to UO331	Output signals for custom macro (Extended signals)	F276,F277 F280 to F283 F284 to F287	○	○	11.6.1
W	WATO	Waiting signal	F063#6	●	●	8.5
	WOQSM	Workpiece coordinate system shift value write mode select signal	G039#6	○	—	14.4.2
	WOSET	Workpiece coordinate system shift value write signal	G040#7	○	—	
X	XAE	Measuring position reached signal	X004#0	○	○	14.2
Y	YAE		X004#1	—	○	
Z	ZAE		X004#1	○	—	
	ZAE		X004#2	—	○	
	ZP1 to ZP8	Reference position return end signal	F094	○	○	4.1
	ZP21 to ZP28	2nd reference position return end signal	F096	○	○	4.5
	ZP31 to ZP38	3rd reference position return end signal	F098	○	○	
	ZP41 to ZP48	4th reference position return end signal	F100	○	○	
	ZRF1 to ZRF8	Reference position establishment signal	F120	○	○	4.1
	ZRN	Manual reference position return selection signal	G043#7	○	○	
ZRNO	Software operator's panel signal(ZRN)	F073#4	○	○	12.1.15	

A.2.3**List of Signals
(In Order of Addresses)**

○	: Available
●	: Available only with 2-path control
–	: Unavailable

Address	Signal name	Symbol	T series	M series	Reference Item
X004#0	Measuring position reached signal	XAE	○	○	14.2
X004#1		YAE	–	○	
X004#1		ZAE	○	–	
X004#2		ZAE	–	○	
X004#2,#4	Manual feed interlock signal for each axis	+MIT1,+MIT2	○	–	2.5
X004#2,#4	Tool offset write signal	+MIT1,+MIT2	○	–	14.4.2
X004#2 to #6,#0,#1	Skip signal	SKIP2 to SKIP6, SKIP7,SKIP8	○	○	14.3.3
X004#3,#5	Manual feed interlock signal for each axis	-MIT1,-MIT2	○	–	2.5
X004#3,#5	Tool offset write signal	-MIT1,-MIT2	○	–	14.4.2
X004#6	Skip signal (PMC axis control)	ESKIP	○	○	15.1
X004#7	Skip signal	SKIP	○	○	14.3.1
X004#7	Overload torque signal	SKIP	–	○	11.17
X008#4	Emergency stop signal	*ESP	○	○	2.1
X009	Reference position return deceleration signal	*DEC1 to *DEC8	○	○	4.1
Y(n+0)	Servo motor speed detection signals	DSV1 to DSV8	○	○	2.11
Y(n+1)#0 to #2	Spindle motor speed detection signals	DSP1, DSP2, DSP3	○	○	
G000,G001	Data signal for external data input	ED0 to ED15	○	○	15.2
G002#0 to #6	Address signal for external data input	EA0 to EA6	○	○	
G002#7	Read signal for external data input	ESTB	○	○	
G004#3	End signal	FIN	○	○	8.1
G004#4	2nd M function completion signal	MFIN2	○	○	8.4
G004#5	3rd M function completion signal	MFIN3	○	○	
G005#0	Auxiliary function completion signal	MFIN	○	○	
G005#1	External operation function completion signal	EFIN	–	○	
G005#2	Spindle function completion signal	SFIN	○	○	
G005#3	Tool function completion signal	TFIN	○	○	
G005#4	2nd auxiliary function completion signal	BFIN	○	–	
G005#6	Auxiliary function lock signal	AFL	○	○	8.2
G005#7	2nd auxiliary function completion signal	BFIN	–	○	8.4
G006#0	Program restart signal	SRN	○	○	5.7
G006#2	Manual absolute signal	*ABSM	○	○	5.4
G006#4	Override cancel signal	OVC	○	○	7.1.7.4
G006#6	Skip signal	SKIPP	○	–	14.3.1
G007#0	Retrace signal	RVS	–	○	11.15

Address	Signal name	Symbol	T series	M series	Reference Item
G007#1	Start lock signal	STLK	○	–	2.5
G007#2	Cycle start signal	ST	○	○	5.1
G007#4	Stroke check 3 release signal	RLSOT3	○	○	2.3.3
G007#5	Follow-up signal	*FLWU	○	○	1.2.7
G007#6	Stored stroke limit select signal	EXLM	○	○	2.3.2
G007#7	Stroke limit release signal	RLSOT	–	○	
G008#0	Interlock signal	*IT	○	○	2.5
G008#1	Cutting block start interlock signal	*CSL	○	○	
G008#3	Block start interlock signal	*BSL	○	○	
G008#4	Emergency stop signal	*ESP	○	○	2.1
G008#5	Feed hold signal	*SP	○	○	5.1
G008#6	Reset & rewind signal	RRW	○	○	5.2
G008#7	External reset signal	ERS	○	○	
G009#0 to 4	Workpiece number search signal	PN1,PN2,PN4, PN8,PN16	○	○	15.3
G010,G011	Manual feedrate override signal	*JV0 to *JV15	○	○	3.1
G012	Feedrate override signal	*FV0 to *FV7	○	○	7.1.7.2
G013	2nd feedrate override signal	*AFV0 to *AFV7	○	○	7.1.7.3
G014#0,#1	Rapid traverse override signal	ROV1,ROV2	○	○	7.1.7.1
G016#0	Motor speed detection function enable signal	MSDFON	○	○	2.11
G016#7	F1-digit feed select signal	F1D	–	○	7.1.5
G018#0 to #3	Manual handle feed axis selection signal	HS1A to HS1D	○	○	3.2
G018#4 to #7		HS2A to HS2D	○	○	
G019#0 to #3		HS3A to HS3D	○	○	
G019#4,#5	Manual handle feed amount selection signal (incremental feed signal)	MP1,MP2	○	○	
G019#7	Manual rapid traverse selection signal	RT	○	○	3.1
G020#0 to #3	Manual handle feed axis select signals	HS4A to HS4D	–	○	3.2
G023#6	Tool axis perpendicular direction handle feed mode signal	RGHTH	–	○	3.4.2
G023#7	Tool axis direction handle feed mode signal	ALNGH	–	○	3.4
G024#0 to G025#5	Expanded workpiece number search signals	EPN0 to EPN13	○	○	15.3.2
G025#7	Expanded workpiece number search start signal	EPNS	○	○	
G026#0	3rd position coder selection signal	PC3SLC	○	○	9.10
G026#1	4th position coder selection signal	PC4SLC	○	○	
G026#3	Spindle selection signals	SWS4	○	○	
G026#6	Individual spindle stop signals	*SSTP4	○	○	
G027#0	Spindle selection signal	SWS1	○	○	9.10
G027#1		SWS2	○	○	
G027#2		SWS3	○	○	

Address	Signal name	Symbol	T series	M series	Reference Item
G027#3	Stop signal in each spindle	*SSTP1	○	○	9.10
G027#4		*SSTP2	○	○	
G027#5		*SSTP3	○	○	
G027#7	Cs contour control switch signal	CON	○	○	9.9
G028#1,#2	Gear selection signal (input)	GR1,GR2	○	○	9.3
G028#4	Spindle unclamp completion signal	*SUCPF	○	—	9.8
G028#5	Spindle clamp completion signal	*SCPF	○	—	
G028#6	Spindle stop complete signal	SPSTP	○	—	
G028#7	2nd position coder selection signal	PC2SLC	○	—	9.10
G029#0	Gear select signal (input)	GR21	○	○	
G029#2		GR31	○	○	
G029#4	Spindle speed arrival signal	SAR	○	○	9.3
G029#5	Spindle orientation signal	SOR	○	○	
G029#6	Spindle stop signal	*SSTP	○	○	
G030	Spindle speed override signal	SOV0 to SOV7	○	○	
G031#4	Gear selection signals (input)	GR41	○	○	9.10
G032#0 to G033#3	Spindle motor speed command signal	R011 to R12I	○	○	15.4
G033#5	Spindle motor command polarity select signal	SGN	○	○	
G033#6		SSIN	○	○	
G033#7	Spindle motor speed command select signal	SIND	○	○	
G034#0 to G035#3	Spindle motor speed command signal	R01I2 to R12I2	○	○	
G035#5	Spindle motor command polarity select signal	SGN2	○	○	
G035#6	Spindle motor command polarity select signal	SSIN2	○	○	
G035#7	Spindle motor speed command select signal	SIND2	○	○	
G036#0 to G037#3	Spindle motor speed command signal	R01I3 to R12I3	○	○	
G037#5	Spindle motor command polarity select signal	SGN3	○	○	
G037#6	Spindle motor command polarity select signal	SSIN3	○	○	
G037#7	Spindle motor speed command select signal	SIND3	○	○	
G038#0	Polygon spindle stop signal	*PLSST	○	—	6.10.2
G038#2	Spindle synchronous control signal	SPSYC	○	○	9.12
G038#3	Spindle phase synchronous control signal	SPPHS	○	○	
G038#6	B-axis unclamp completion signal	*BEUCP	—	○	11.11
G038#7	B-axis clamp completion signal	*BECLP	—	○	
G039#0 to #5,G040#0	Tool offset number select signal	OFN0 to OFN5, OFN6	○	—	14.4.2
G039#6	Workpiece coordinate system shift value write mode select signal	WOQSM	○	—	
G039#7	Tool offset value write mode select signal	GOQSM	○	—	
G040#5	Spindle measurement select signal	S2TLS	○	—	14.4
G040#6	Position record signal	PRC	○	—	14.4.1

Address	Signal name	Symbol	T series	M series	Reference Item
G040#7	Workpiece coordinate system shift value write signal	WOSET	○	–	14.4.2
G041#0 to #3	Manual handle interrupt axis selection signal	HS1IA to HS1ID	○	○	3.3
G041#4 to #7		HS2IA to HS2ID	○	○	
G042#0 to #3		HS3IA to HS3ID	○	○	
G042#7	Direct operation select signal	DMMC	○	○	15.6
G043#0 to #2	Mode selection signal	MD1,MD2,MD4	○	○	2.6
G043#5	DNC operation select signal	DNCI	○	○	5.11
G043#7	Manual reference position return selection signal	ZRN	○	○	4.1
G044#0,G045	Optional block skip signal	BDT1, BDT2 to BDT9	○	○	5.5
G044#1	All-axis machine lock signal	MLK	○	○	5.3.1
G046#0	Parameter write setting signal	KEYPRM	○	○	12.2.3
G046#1	Single block signal	SBK	○	○	5.3.3
G046#3 to #6	Memory protect signal	KEY1 to KEY4	○	○	12.2.3
G046#7	Dry run signal	DRN	○	○	5.3.2
G047#0 to #6	Tool group number select signal	TL01 to TL64	○	–	10.3
G047#0 to G048#0		TL01 to TL256	–	○	
G048#5	Tool skip signal	TLSKP	○	○	
G048#6	Individual tool change reset signal	TLRSTI	–	○	
G048#7	Tool change reset signal	TLRST	○	○	
G049#0 to G050#1	Tool life count override signal	*TLV0 to *TLV9	–	○	
G051#0 to #3	Chopping feedrate override signals	*CHP8 to *CHP0	–	○	
G051#6	Chopping start signal	CHPST	–	○	1.12
G051#7	Chopping hold signal	*CHLD	–	○	
G052	Input signal for remote buffer	RMTDI0 to RMTDI7	○	○	13.2
G053#0	General-purpose integrating meter start signal	TMRON	○	○	12.1.11
G053#3	Interrupt signal for custom macro	UINT	○	○	11.6.2
G053#6	Error detect signal	SMZ	○	–	7.2.6.3
G053#7	Chamferring signal	CDZ	○	–	11.9
G054,G055	Input signal for custom macro	UI000 to UI015	○	○	11.6.1
G056,G057	Input signals for custom macro (Extended signals)	UI016 to UI031	○	○	11.6.1
G058#0	External start signal program input	MINP	○	○	13.7
G058#1	External read start signal	EXRD	○	○	13.8, 13.5
G058#2	External read/punch stop signal	EXSTP	○	○	
G058#3	External punch start signal	EXWT	○	○	
G058#5	Input and run simultaneous mode select signal	STRD	–	○	13.6
G058#6	Output and run simultaneous mode select signal	STWD	–	○	
G059#0	Tool retraction signal	TRESC	○	○	5.8
G059#1	Tool return signal	TRRTN	○	○	
G060#7	Tail stock barrier select signal	*TSB	○	–	2.3.4

Address	Signal name	Symbol	T series	M series	Reference Item
G061#0	Rigid tapping signal	RGTAP	○	○	9.11
G061#4,#5	Rigid tap spindle select signal	RGTSP1, RGTSP2	○	—	
G062#1	Automatic erase CRT screen display cancel signal	*CRTOF	○	○	12.1.19
G062#4	Conversation mode selection signal	PDT1	○	—	
G062#5	Restart operation notification signal	PDT2	○	—	
G062#6	Rigid tapping retraction start signal	RTNT	—	○	5.13
G063#0	Path selection signal (Tool post selection signal)	HEAD	●	●	2.7
G063#1	No—wait signal	NOWT	●	●	8.5
G063#2,#3	Spindle command select signal	SLSPA,SLSPB	●	—	9.4
G063#5	Perpendicular/angular axis control disable signal	NOZAGC	○	○	1.11
G064#2,#3	Spindle feedback select signal	SLPCA,SLPCB	●	—	9.4
G064#6	Simple spindle synchronous control signal	ESRSYC	○	○	9.16
G065#4 to 7	Skip signals for high—speed cycle machining	HCSKP1 to HCSKP4	○	○	11.19
G066#0	All—axis VRDY OFF alarm ignore signal	IGNVRY	○	○	2.9
G066#1	External key input mode selection signal	ENBKY	○	○	15.5
G066#2	Cancel—sync—with—C—axis signal	HOBKAN	○	○	1.13
G066#4	Retract signal	RTRCT	○	○	1.13 1.14.1 1.14.2 1.14.4 1.16
G066#5	One—rotation position manual set signal	MSPC	○	○	1.13
G066#7	Key code read signal	EKSET	○	○	15.5
G067#1	Check mode backward movement inhibition signal	MRVM	○	—	5.3.4
G067#2	Check mode signal	MMOD	○	—	
G067#3	Check mode handle valid signal	MCHK	○	—	
G067#6	Hard copy stop request signal	HCABT	○	○	13.9
G067#7	Hard copy request signal	HCREQ	○	○	
G070#0	Torque limit command LOW signal (serial spindle)	TLMLA	○	○	9.2
G070#1	Torque limit command HIGH signal (serial spindle)	TLMHA	○	○	
G070#3,#2	Clutch/gear signal (serial spindle)	CTH1A,CTH2A	○	○	
G070#4	CCW command signal (serial spindle)	SRVA	○	○	
G070#5	CW command signal (serial spindle)	SFRA	○	○	
G070#6	Orientation command signal (serial spindle)	ORCMA	○	○	
G070#7	Machine ready completion signal (serial spindle)	MRDYA	○	○	
G071#0	Alarm reset signal (serial spindle)	ARSTA	○	○	
G071#1	Emergency stop signal (serial spindle)	*ESPA	○	○	
G071#2	Spindle select signal (serial spindle)	SPSLA	○	○	
G071#3	Power line switch completion signal (serial spindle)	MCFNA	○	○	
G071#4	Soft start stop cancel signal (serial spindle)	SOCNA	○	○	

Address	Signal name	Symbol	T series	M series	Reference Item
G071#5	Signal for controlling velocity integration (serial spindle)	INTGA	○	○	9.2 9.15
G071#6	Output switch request signal (serial spindle)	RSLA	○	○	9.2
G071#7	Power line status check signal (serial spindle)	RCHA	○	○	
G072#0	Orientation stop position change signal (serial spindle)	INDXA	○	○	9.2 9.15
G072#1	Rotation direction command while changing the orientation stop position signal (serial spindle)	ROTAA	○	○	
G072#2	Short-distant movement command while changing the orientation stop position signal (serial spindle)	NRROA	○	○	
G072#3	Differential mode command signal (serial spindle)	DEFMDA	○	○	
G072#4	Analog override command signal (serial spindle)	OVRA	○	○	
G072#5	Incremental command external setting type orientation signal (serial spindle)	INCMDA	○	○	
G072#6	Main spindle MCC status signal while changing spindles signal (serial spindle)	MFNHGA	○	○	
G072#7	High-output MCC status signal while a magnetic sensor (serial spindle)	RCHHGA	○	○	
G073#0	Command for spindle orientation with a magnetic sensor (serial spindle)	MORCMA	○	○	
G073#1	Slave operation command signal (serial spindle)	SLVA	○	○	
G073#2	Motor power stop signal (serial spindle)	MPOFA	○	○	
G073#4	Disconnection detection disable signal (serial spindle)	DSCNA	○	○	
G074#0	Torque limit command LOW signal (serial spindle)	TLMLB	○	○	
G074#1	Torque limit command HIGH signal (serial spindle)	TLMHB	○	○	
G074#3,#2	Clutch/gear signal (serial spindle)	CTH1B,CTH2B	○	○	
G074#4	CCW command signal (serial spindle)	SRVB	○	○	
G074#5	CW command signal (serial spindle)	SFRB	○	○	
G074#6	Orientation command signal (serial spindle)	ORCMB	○	○	
G074#7	Machine ready completion signal (serial spindle)	MRDYB	○	○	
G075#0	Alarm reset signal (serial spindle)	ARSTB	○	○	
G075#1	Emergency stop signal (serial spindle)	*ESPB	○	○	
G075#2	Spindle select signal (serial spindle)	SPSLB	○	○	
G075#3	Power line switch completion signal (serial spindle)	MCFNB	○	○	
G075#4	Soft start stop cancel signal (serial spindle)	SOCNB	○	○	
G075#5	Signal for controlling velocity integration (serial spindle)	INTGB	○	○	9.2 9.15
G075#6	Output switch request signal (serial spindle)	RSLB	○	○	9.2
G075#7	Power line status check signal (serial spindle)	RCHB	○	○	

Address	Signal name	Symbol	T series	M series	Reference Item
G076#0	Orientation stop position change signal (serial spindle)	INDXB	○	○	9.2 9.15
G076#1	Rotation direction command while changing the orientation stop position signal (serial spindle)	ROTAB	○	○	
G076#2	Short-distant movement command while changing the orientation stop position signal (serial spindle)	NRROB	○	○	
G076#3	Differential mode command signal (serial spindle)	DEFMDB	○	○	
G076#4	Analog override command signal (serial spindle)	OVRB	○	○	9.2 9.15
G076#5	Incremental command external setting type orientation signal (serial spindle)	INCMDB	○	○	
G076#6	Main spindle MCC status signal while changing spindles signal (serial spindle)	MFNHGB	○	○	
G076#7	High-output MCC status signal while a magnetic sensor (serial spindle)	RCHHGB	○	○	
G077#0	Command for spindle orientation with a magnetic sensor (serial spindle)	MORCMB	○	○	
G077#1	Slave operation command signal (serial spindle)	SLVB	○	○	
G077#2	Motor power stop signal (serial spindle)	MPOFB	○	○	
G077#4	Disconnection detection disable signal (serial spindle)	DSCNB	○	○	9.13
G078#0 to G079#3 G080#0 to G081#3	Spindle orientation external stop position command signal	SHA00 to SHA11 SHB00 to SHB11	○ ○	○ ○	
G086#0 to #3	Feed axis and direction selection signals	+Jg, -Jg, +Ja, -Ja	○	○	3.5
G087#0,#1	Manual handle feed travel distance select signals (incremental feed signals)	MP21, MP22	○	○	3.2
G087#3,#4	Manual handle feed travel distance select signals (incremental feed signals)	MP31, MP32	○	○	
G087#6,#7	Manual handle feed travel distance select signals (incremental feed signals)	MP41, MP42	-	○	
G088#4 to #7	Manual handle feed axis select signals	HS4IA to HS4ID	-	○	10.2
G090#0	Tool offset direction signal	G2RVX	○	-	
G090#1	Tool offset direction signal	G2RVZ	○	-	
G090#2	Tool offset direction signal	G2RVY	○	-	
G090#4	Second figure tool offset axis select signal	G2RVX	○	-	
G090#5	Second figure tool offset axis select signal	G2RVZ	○	-	
G090#6	Second figure tool offset axis select signal	G2RVY	○	-	
G090#7	Second figure tool offset signal	G2SLC	○	-	13.8
G091#0 to #3	Group number specification signals	SRLNI0 to SRLNI3	○	○	
G092#0	I/O Link confirmation signal	IOLACK	○	○	
G092#1	I/O Link specification signal	IOLS	○	○	
G092#2	Power Mate read/write inprogress signal	BGION	○	○	
G092#3	Power Mate read/write alarm signal	BGIALM	○	○	
G092#4	Power Mate background busy signal	BGEN	○	○	7.1.7.1
G096#0 to #6 G096#7	1% step rapid traverse override signal 1% step rapid traverse override select signal	*HROV0 to *HROV6 HROV	○ ○	○ ○	

Address	Signal name	Symbol	T series	M series	Reference Item
G098	Key code signal	EKC0 to EKC7	○	○	15.5
G100	Feed axis and direction selection signal	+J1 to +J8	○	○	3.1
G102		-J1 to -J8	○	○	
G104	Axis direction dependent stored stroke limit switch signal	+EXL1 to +EXL8	○	○	2.3.2
G105		-EXL1 to -EXL8	○	○	
G106	Mirror image signal	M1 to M8	○	○	1.2.6
G108	Each-axis machine lock signal	MLK1 to MLK8	○	○	5.3.1
G110	Stroke limit external setting signal	+LM1 to +LM8	—	○	2.3.2
G112		-LM1 to -LM8	—	○	
G114	Overtravel signal	*+L1 to *+L8	○	○	2.3.1
G116		*-L1 to *-L8	○	○	
G118	External deceleration signal	*+ED1 to *+ED8	○	○	7.1.9
G120		*-ED1 to *-ED8	○	○	
G122	Parking signals	PK1 to PK8	○	—	1.8
G122#0 to #6		PK1 to PK7	●	—	1.9
G122#6 (G031#6)	First spindle synchronous control signal	PKESS1	○	○	9.16
G122#7 (G031#7)	Second spindle synchronous control signal	PKESS2	○	○	
G124	Controlled axis detach signal	DTCH1 to DTCH8	○	○	1.2.4
G125	Abnormal load detection ignore signal	IUDD1 to IUDD8	○	○	2.10
G126	Servo off signal	SVF1 to SVF8	○	○	1.2.8
G128#0 to #6	Composite control axis selection signals	MIX1 to MIX7	●	—	1.9
G130	Interlock signal for each axis	*IT1 to *IT8	○	○	2.5
G132#0 to #3	Interlock signal for each axis and direction	+MIT1 to +MIT4	—	○	
G134#0 to #3		-MIT1 to -MIT4	—	○	
G136	Control axis select signal (PMC axis control)	EAX1 to EAX8	○	○	15.1
G138	Simple synchronous axis select signal	SYNC1 to SYNC8	○	○	1.6
G138	Synchronous control axis selection signals	SYNC1 to SYNC8	○	—	1.8
G138#0 to #6		SYNC1 to SYNC7	●	—	1.9
G140	Simple synchronous manual feed axis select signal	SYNCJ1 to SYNCJ8	—	○	1.6

Address	Signal name	Symbol	T series	M series	Reference Item
G142#0	Auxiliary function completion signal (PMC axis control)	EFINA	○	○	15.1
G142#1	Accumulated zero check signal	ELCKZA	○	○	
G142#2	Buffering disable signal (PMC axis control)	EMBUFA	○	○	
G142#3	Block stop signal (PMC axis control)	ESBKA	○	○	
G142#4	Servo off signal (PMC axis control)	ESOFA	○	○	
G142#5	Axis control temporary stop signal (PMC axis control)	ESTPA	○	○	
G142#6	Reset signal (PMC axis control)	ECLRA	○	○	
G142#7	Axis control command read signal (PMC axis control)	EBUFA	○	○	
G143#0 to #6	Axis control command signal (PMC axis control)	EC0A to EC6A	○	○	
G143#7	Block stop disable signal (PMC axis control)	EMSBKA	○	○	
G144,G145	Axis control feedrate signal (PMC axis control)	EIF0A to EIF15A	○	○	
G146 to G149	Axis control data signal (PMC axis control)	EID0A to EID31A	○	○	
G150#0,#1	Rapid traverse override signal (PMC axis control)	ROV1E,ROV2E	○	○	
G150#5	Override cancel signal (PMC axis control)	OVCE	○	○	

Address	Signal name	Symbol	T series	M series	Reference Item
G150#6	Manual rapid traverse selection signal (PMC axis control)	RTE	○	○	15.1
G150#7	Dry run signal (PMC axis control)	DRNE	○	○	
G151	Feedrate override signal (PMC axis control)	*FV0E to *FV7E	○	○	
G154#0	Auxiliary function completion signal (PMC axis control)	EFINB	○	○	
G154#1	Accumulated zero check signal	ELCKZB	○	○	
G154#2	Buffering disable signal (PMC axis control)	EMBUFB	○	○	
G154#3	Block stop signal (PMC axis control)	ESBKB	○	○	
G154#4	Servo off signal (PMC axis control)	ESOFB	○	○	
G154#5	Axis control temporary stop signal (PMC axis control)	ESTPB	○	○	
G154#6	Reset signal (PMC axis control)	ECLRB	○	○	
G154#7	Axis control command read signal (PMC axis control)	EBUFB	○	○	
G155#0 to #6	Axis control command signal (PMC axis control)	EC0B to EC6B	○	○	
G155#7	Block stop disable signal (PMC axis control)	EMSBKB	○	○	
G156,G157	Axis control feedrate signal (PMC axis control)	EIF0B to EIF15B	○	○	
G158 to G161	Axis control data signal (PMC axis control)	EID0B to EID31B	○	○	
G166#0	Auxiliary function completion signal (PMC axis control)	EFINC	○	○	
G166#1	Accumulated zero check signal	ELCKZC	○	○	
G166#2	Buffering disable signal (PMC axis control)	EMBUFC	○	○	
G166#3	Block stop signal (PMC axis control)	ESBKC	○	○	
G166#4	Servo off signal (PMC axis control)	ESOFC	○	○	
G166#5	Axis control temporary stop signal (PMC axis control)	ESTPC	○	○	
G166#6	Reset signal (PMC axis control)	ECLRC	○	○	
G166#7	Axis control command read signal (PMC axis control)	EBUFC	○	○	
G167#0 to #6	Axis control command signal (PMC axis control)	EC0C to EC6C	○	○	
G167#7	Block stop disable signal (PMC axis control)	EMSBKC	○	○	
G168,G169	Axis control feedrate signal (PMC axis control)	EIF0C to EIF15C	○	○	
G170 to G173	Axis control data signal (PMC axis control)	EID0C to EID31C	○	○	
G178#0	Auxiliary function completion signal (PMC axis control)	EFIND	○	○	
G178#1	Accumulated zero check signal	ELCKZD	○	○	
G178#2	Buffering disable signal (PMC axis control)	EMBUFD	○	○	
G178#3	Block stop signal (PMC axis control)	ESBKD	○	○	
G178#4	Servo off signal (PMC axis control)	ESOFD	○	○	
G178#5	Axis control temporary stop signal (PMC axis control)	ESTPD	○	○	
G178#6	Reset signal (PMC axis control)	ECLRD	○	○	
G178#7	Axis control command read signal (PMC axis control)	EBUFD	○	○	
G179#0 to #6	Axis control command signal (PMC axis control)	EC0D to EC6D	○	○	
G179#7	Block stop disable signal (PMC axis control)	EMSBKD	○	○	
G180,G181	Axis control feedrate signal (PMC axis control)	EIF0D to EIF15D	○	○	
G182 to G185	Axis control data signal (PMC axis control)	EID0D to EID31D	○	○	

Address	Signal name	Symbol	T series	M series	Reference Item
G190#0 to #6	Superimposed control axis selection signals	OVLS1 to OVLS7	●	–	1.9
G192	Each-axis VRDY OFF alarm ignore signal	IGVRY1 to IGVRY8	○	○	2.9
G197#0 to #3	Flexible synchronization control mode select signals	MTA to MTD	–	○	1.15
G198	Position display neglect signal	NPOS1 to NPOS8	○	○	12.1.10
G199#0	Manual handle feed generator selection signals	IOLBH2	○	○	16.1
G199#1	Manual handle feed generator selection signals	IOLBH3	○	○	
G200	Axis control superimposed command signal	EASIP1 to EASIP8	○	○	15.1
G201#3 to #5	Signals for setting the jog feed stop position	JGRD1 to 3	○	–	3.9
G203#0	Torque sensing command signal	FTCMD	○	○	12.1.23
G203#1	Statistical calculation start signal	FTCAL	○	○	
G203#2	Store counter clear signal	FTCLR	○	○	
G204#0	Torque limit command LOW signal (serial spindle)	TLMLC	○	○	9.2 9.15
G204#1	Torque limit command HIGH signal (serial spindle)	TLMHC	○	○	
G204#3,#2	Clutch/gear signal (serial spindle)	CTH1C,CTH2C	○	○	
G204#4	CCW command signal (serial spindle)	SRVC	○	○	
G204#5	CW command signal (serial spindle)	SFRC	○	○	
G204#6	Orientation command signal (serial spindle)	ORCMC	○	○	
G204#7	Machine ready signal (serial spindle)	MRDYC	○	○	
G205#0	Alarm reset signal (serial spindle)	ARSTC	○	○	
G205#1	Emergency stop signal (serial spindle)	*ESPC	○	○	
G205#2	Spindle select signal (serial spindle)	SPSLC	○	○	
G205#3	Power line switch completion signal (serial spindle)	MCFNC	○	○	
G205#4	Soft start/stop cancel signal (serial spindle)	SOCNC	○	○	
G205#5	Signal for controlling velocity integration (serial spindle)	INTGC	○	○	
G205#6	Output switch request signal (serial spindle)	RSLC	○	○	
G205#7	Power line status check signal (serial spindle)	RCHC	○	○	
G206#0	Orientation stop position change signal (serial spindle)	INDXC	○	○	
G206#1	Rotation direction command while changing the orientation stop position signal (serial spindle)	ROTAC	○	○	
G206#2	Short-distant movement command while changing the orientation stop position signal (serial spindle)	NRROC	○	○	
G206#3	Differential mode command signal (serial spindle)	DEFMDC	○	○	
G206#4	Analog override command signal (serial spindle)	OVRC	○	○	
G206#5	Incremental command external setting type orientation signal (serial spindle)	INCMDC	○	○	
G206#6	Main spindle MCC status signal while changing spindles signal (serial spindle)	MFNHGC	○	○	
G206#7	High-output MCC status signal while a magnetic sensor (serial spindle)	RCHHGC	○	○	
G207#0	Command for spindle orientation with a magnetic sensor (serial spindle)	MORCMC	○	○	
G207#1	Slave operation command signal (serial spindle)	SLVC	○	○	

Address	Signal name	Symbol	T series	M series	Reference Item
G207#2	Motor power stop signal (serial spindle)	MPOFC	○	○	9.2 9.15
G207#4	Disconnection detection disbale signal (serial spindle)	DSCNC	○	○	
G208#0 to G209#3	Spindle orientation stop position external command signal	SHC00 to SHC11	○	○	9.15
G266#0	Torque limit command LOW signal (serial spindle)	TMLD	○	○	9.2 9.15
G266#1	Torque limit command HIGH signal (serial spindle)	TLMHD	○	○	
G266#3, #2	Clutch/gear signal (serial spindle)	CTH1D, CTH2D	○	○	
G266#4	CCW command signal (serial spindle)	SRVD	○	○	
G266#5	CW command signal (serial spindle)	SFRD	○	○	
G266#6	Orientation command signal (serial spindle)	ORCMD	○	○	
G266#7	Machine ready completion signal (serial spindle)	MRDYD	○	○	
G267#0	Alarm reset signal (serial spindle)	ARSTD	○	○	
G267#1	Emergency stop signal (serial spindle)	*ESPD	○	○	
G267#2	Spindle select signal (serial spindle)	SPSLD	○	○	
G267#3	Power line switch completion signal (serial spindle)	MCFND	○	○	
G267#4	Soft start stop cancel signal (serial spindle)	SOCND	○	○	
G267#5	Signal for controlling velocity integration (serial spindle)	INTGD	○	○	
G267#6	Output switch request signal (serial spindle)	RSLD	○	○	
G267#7	Power line status check signal (serial spindle)	RCHD	○	○	
G268#0	Orientation stop position change signal (serial spindle)	INDXD	○	○	
G268#1	Rotation direction command while changing the orientation stop position signal (serial spindle)	ROTAD	○	○	
G268#2	Short-distant movement command while changing the orientation stop position signal (serial spindle)	NRROD	○	○	
G268#3	Differential mode command signal (serial spindle)	DEFMDD	○	○	
G268#4	Analog override command signal (serial spindle)	OVRD	○	○	
G268#5	Incremental command external setting type orientation signal (serial spindle)	INCMDD	○	○	
G268#6	Main spindle MCC status signal while changing spindles signal (serial spindle)	MFNHGD	○	○	
G268#7	High-output MCC status signal while a magnetic sensor (serial spindle)	RCHHGD	○	○	
G269#0	Command for spindle orientaion with a magnetic sensor (serial spindle)	MORCMD	○	○	
G269#1	Slave operation command signal (serial spindle)	SLVD	○	○	
G269#2	Motor power stop signal (serial spindle)	MROFD	○	○	
G269#4	Disconnection detection disbale signal (serial spindle)	DSCND	○	○	
G270#0 to G271#3	Spindle orientation stop position external command signal	SHD00 to SHD11	○	○	
G272#0 to G273#3	Spindle motor speed command signal	R01I4 to R12I4	○	○	15.4
G273#5	Spindle motor command polarity select signal	SGN4	○	○	
G273#6	Spindle motor command polarity select signal	SSIN4	○	○	
G273#7	Spindle motor speed command select signal	SIND4	○	○	
G274#4	Cs-axis coordinate establishment request signal	CSF11	○	○	9.9.2

Address	Signal name	Symbol	T series	M series	Reference Item
G276 to G279 G280 to G283 G284 to G287	Input signals for custom macro (Extended signals)	UI100 to UI131 UI200 to UI231 UI300 to UI331	○	○	11.6.1
G292#7	Rotation area interference check disable signal	ITCD	○	○	2.3.7
F000#0	Rewinding signal	RWD	○	○	5.2
F000#4	Feed hold lamp signal	SPL	○	○	5.1
F000#5	Cycle start lamp signal	STL	○	○	5.1
F000#6	Servo ready completion signal	SA	○	○	2.2
F000#7	Automatic operation signal	OP	○	○	5.1
F001#0	Alarm signal	AL	○	○	2.4
F001#1	Resetting signal	RST	○	○	5.2
F001#2	Battery alarm signal	BAL	○	○	2.4
F001#3	Distribution end signal	DEN	○	○	8.1
F001#4	Spindle enable signal	ENB	○	○	9.3
F001#5	Tapping signal	TAP	○	○	11.7
F001#7	CNC signal	MA	○	○	2.2
F002#0	Inch input signal	INCH	○	○	11.4
F002#1	Rapid traversing signal	RPDO	○	○	2.8
F002#2	Constant surface speed signal	CSS	○	○	9.5
F002#3	Thread cutting signal	THRD	○	○	6.4.1
F002#4	Program restart under way signal	SRNMV	○	○	5.7
F002#6	Cutting feed signal	CUT	○	○	2.8
F002#7	Dry run check signal	MDRN	○	○	5.3.2
F003#0	Incremental feed select check signal	MINC	○	○	2.6
F003#1	Manual handle feed select check signal	MH	○	○	
F003#2	Jog feed select check signal	MJ	○	○	
F003#3	Manual data input select check signal	MMDI	○	○	
F003#4	DNC operation selection confirm signal	MRMT	○	○	5.11
F003#5	Automatic operation select check signal	MMEM	○	○	2.6
F003#6	Memory edit select check signal	MEDT	○	○	
F003#7	TEACH IN select check signal	MTCHIN	○	○	
F004#0,F005	Optional block skip check signal	MBDT1,MBDT2 to MBDT9	○	○	5.5
F004#1	All-axis machine lock check signal	MMLK	○	○	5.3.1
F004#2	Manual absolute check signal	MABSM	○	○	5.4
F004#3	Single block check signal	MSBK	○	○	5.3.3
F004#4	Auxiliary function lock check signal	MAFL	○	○	8.2
F004#5	Manual reference position return selection check signal	MREF	○	○	4.1
F007#0	Miscellaneous function strobe signal	MF	○	○	8.1
F007#1	External operation signal for high-speed interface	EFD	—	○	8.4

Address	Signal name	Symbol	T series	M series	Reference Item
F007#2	Spindle-speed function strobe signal	SF	○	○	8.1
F007#3	Tool function strobe signal	TF	○	○	
F007#4	2nd auxiliary function strobe signal	BF	○	—	
F007#7		BF	—	○	
F008#0	External operation signal	EF	—	○	11.8
F008#4	2nd M function strobe signal	MF2	○	○	8.3
F008#5	3rd M function strobe signal	MF3	○	○	
F009#4	Decode M signal	DM30	○	○	8.1
F009#5		DM02	○	○	
F009#6		DM01	○	○	
F009#7		DM00	○	○	
F010 to F013	Miscellaneous function code signal	M00 to M31	○	○	8.3
F014 to F015	2nd M function code signal	M200 to M215	○	○	
F016 to F017	3rd M function code signal	M300 to M315	○	○	
F022 to F025	Spindle speed code signal	S00 to S31	○	○	8.1
F026 to F029	Tool function code signal	T00 to T31	○	○	
F030 to F033	2nd miscellaneous function code signal	B00 to B31	○	○	
F034#0 to #2	Gear selection signal (output)	GR10,GR20, GR30	—	○	9.3
F034#6 to #3	Ready signals for the first to fourth serial spindle operations	SRSP1R to SRSP4R	○	○	9.9.2
F034#7	Ready signal for serial spindle operation	SRSRDY	○	○	18.1.6
F035#0	Spindle fluctuation detection alarm signal	SPAL	○	○	9.6
F036#0 to F037#3S	12-bit code signal	R010 to R120	○	○	9.3
F038#0	Spindle clamp signal	SCLP	○	—	9.8
F038#1	Spindle unclamp signal	SUCLP	○	—	
F038#2	Spindle enable signals	ENB2	○	○	9.10
F038#3		ENB3	○	○	
F039#1		ENB4	○	○	
F039#2	Chopping-in-progress signal	CHPMD	—	○	1.12
F039#3	Chopping cycle signal	CHPCYL	—	○	
F040,F041	Actual spindle speed signal	AR0 to AR15	○	—	9.7
F044#1	Cs contour control switch completion signal	FSCSL	○	○	9.9
F044#2	Spindle synchronous speed control completion signal	FSPSY	○	○	9.12 9.16
F044#3	Spindle phase synchronous control completion signal	FSPPH	○	○	
F044#4	Spindle synchronous control alarm signal	SYCAL	○	○	
F045#0	Alarm signal (serial spindle)	ALMA	○	○	9.2
F045#1	Speed zero signal (serial spindle)	SSTA	○	○	

Address	Signal name	Symbol	T series	M series	Reference Item
F045#2	Speed detection signal (serial spindle)	SDTA	○	○	9.2
F045#3	Speed arrival signal (serial spindle)	SARA	○	○	
F045#4	Load detection signal 1 (serial spindle)	LDT1A	○	○	
F045#5	Load detection signal 2 (serial spindle)	LDT2A	○	○	
F045#6	Torque limit signal (serial spindle)	TLMA	○	○	
F045#7	Orientation completion signal (serial spindle)	ORARA	○	○	
F046#0	Power line switch signal (serial spindle)	CHPA	○	○	
F046#1	Spindle switch completion signal (serial spindle)	CFINA	○	○	
F046#2	Output switch signal (serial spindle)	RCHPA	○	○	
F046#3	Output switch completion signal (serial spindle)	RCFNA	○	○	
F046#4	Slave operation status signal (serial spindle)	SLVSA	○	○	9.2 9.15
F046#5	Signal for approximate spindle orientation with a position coder (serial spindle)	PORA2A	○	○	
F046#6	Signal for completion of spindle orientation with a magnetic sensor (serial spindle)	MORA1A	○	○	
F046#7	Signal for approximate spindle orientation with a magnetic sensor (serial spindle)	MORA2A	○	○	
F047#0	Signal indicating the status of the detected one-rotation position coder signal (serial spindle)	PC1DTA	○	○	
F047#1	Incremental method orientation signal (serial spindle)	INCSTA	○	○	
F047#4	Motor activation off status signal (serial spindle)	EXOFA	○	○	
F048#4	Cs-axis coordinate establishment status signal	CSPENA	○	○	9.9.2
F049#0	Alarm signal (serial spindle)	ALMB	○	○	9.2
F049#1	Speed zero signal (serial spindle)	SSTB	○	○	
F049#2	Speed detection signal (serial spindle)	SDTB	○	○	
F049#3	Speed arrival signal (serial spindle)	SARB	○	○	
F049#4	Load detection signal 1 (serial spindle)	LDT1B	○	○	
F049#5	Load detection signal 2 (serial spindle)	LDT2B	○	○	
F049#6	Torque limit signal (serial spindle)	TLMB	○	○	
F049#7	Orientation completion signal (serial spindle)	ORARB	○	○	
F050#0	Power line switch signal (serial spindle)	CHPB	○	○	
F050#1	Spindle switch completion signal (serial spindle)	CFINB	○	○	
F050#2	Output switch signal (serial spindle)	RCHPB	○	○	9.2 9.15
F050#3	Output switch completion signal (serial spindle)	RCFNB	○	○	
F050#4	Slave operation status signal (serial spindle)	SLVSB	○	○	
F050#5	Signal for approximate spindle orientation with a position coder (serial spindle)	PORA2B	○	○	
F050#6	Signal for completion of spindle orientation with a magnetic sensor (serial spindle)	MORA1B	○	○	
F050#7	Signal for approximate spindle orientation with a magnetic sensor (serial spindle)	MORA2B	○	○	

Address	Signal name	Symbol	T series	M series	Reference Item
F051#0	Signal indicating the status of the detected one-rotation position coder signal (serial spindle)	PC1DTB	○	○	9.2 9.15
F051#1	Incremental method orientation signal (serial spindle)	INCSTB	○	○	
F051#4	Motor activation off status signal (serial spindle)	EXOFB	○	○	
F053#0	Key input disable signal	INHKY	○	○	15.5
F053#1	Program screen display mode signal	PRGDPL	○	○	
F053#2	Read/punch in-progress signal	RPBSY	○	○	13.8, 13.5
F053#3	Read/punch alarm signal	RPALM	○	○	
F053#4	Background busy signal	BGEACT	○	○	
F053#7	Key code read completion signal	EKENB	○	○	15.5
F054, F055	Output signal for custom macro	UO000 to UO015	○	○	11.6.1
F056 to F059		UO100 to UO131	○	○	
F060#0	Read completion signal for external data input	EREND	○	○	15.2
F060#1	Search completion signal for external data input	ESEND	○	○	
F060#2	Search cancel signal for external data input	ESCAN	○	○	
F061#0	B-axis unclamp signal	BUCLP	–	○	11.11
F061#1	B-axis clamp signal	BCLP	–	○	
F061#2	Hard copy stop request acceptance flag	HCAB2	○	○	13.9
F061#3	Hard copy in-progress signal	HCEXE	○	○	
F062#0	AI contour control, AI nano contour control, or AI advanced control mode signal	AICC	–	○	7.1.16 7.1.17
F062#3	Spindle 1 under measurement signal	S1MES	○	–	14.4
F062#4	Spindle 2 under measurement signal	S2MES	○	–	
F062#7	Target part count reached signal	PRTSF	○	○	12.1.11
F063#0	Master axis not arrival signal	PSE1	○	–	6.10.2
F063#1	Polygon synchronous axis not arrival signal	PSE2	○	–	
F063#2	Spindle polygon speed arrival signal	PSAR	○	–	
F063#6	Waiting signal	WATO	●	●	8.5
F063#7	Polygon synchronization under way signal	PSYN	○	–	6.10.1
F064#0	Tool change signal	TLCH	○	○	10.3
F064#1	New tool select signal	TLNW	○	○	
F064#2	Individual tool change signal	TLCHI	–	○	
F064#3	Tool life arrival notice signal	TLCHB	–	○	10.3.3
F064#5	Spindle command signal	COSP	●	–	9.4
F064#6	Tool post interference check signal	TICLK	●	–	2.3.5
F064#7	tool post interference alarm signal	TIALM	●	–	
F065#0	Spindle rotation direction signal	RGSPP	–	○	9.11
F065#1		RGSPM	–	○	

Address	Signal name	Symbol	T series	M series	Reference Item
F065#4	Retract completion signal	RTRCTF	○	○	1.13 1.14.1 1.14.2 1.14.4 1.16
F065#5	One-rotation position setting completed signal	MSPCF	○	○	1.13
F065#6	EGB mode signal	SYNMOD	—	○	1.13 1.14
F065#7	Sync-with-C-axis signal	HOBSYN	○	○	1.13
F066#0	Lock-ahead control mode signal	G08MD	○	○	7.1.13
F066#1	Rigid tapping retraction completion signal	RTPT	—	○	5.13
F066#5	Small-diameter peck drilling in progress signal	PECK2	—	○	11.17
F066#6	HPCC mode signal	MHPCC	—	○	7.1.14
F066#7	HPCC operation signal	EXHPCC	—	○	
F069	Output signal for remote buffer	RMTDO0 to RMTDO7	○	○	13.2
F070#0 to F071#7	Position switch signal	PSW01 to PSW16	○	○	1.2.9
F072	Software operator's panel general-purpose switch signal	OUT0 to OUT7	○	○	12.1.15
F073#0	Software operator's panel signal (MD1)	MD1O	○	○	
F073#1	Software operator's panel signal (MD2)	MD2O	○	○	
F073#2	Software operator's panel signal (MD4)	MD4O	○	○	
F073#4	Software operator's panel signal (ZRN)	ZRNO	○	○	
F075#2	Software operator's panel signal (BDT)	BDTO	○	○	
F075#3	Software operator's panel signal (SBK)	SBKO	○	○	
F075#4	Software operator's panel signal (MLK)	MLKO	○	○	
F075#5	Software operator's panel signal (DRN)	DRNO	○	○	
F075#6	Software operator's panel signal (KEY1 to KEY4)	KEYO	○	○	
F075#7	Software operator's panel signal (*SP)	SPO	○	○	
F076#0	Software operator's panel signal (MP1)	MP1O	○	○	
F076#1	Software operator's panel signal (MP2)	MP2O	○	○	
F076#3	Rigid tapping mode signal	RTAP	○	○	
F076#4	Software operator's panel signal (ROV1)	ROV1O	○	○	12.1.15
F076#5	Software operator's panel signal (ROV2)	ROV2O	○	○	
F077#0	Software operator's panel signal (HS1A)	HS1AO	○	○	
F077#1	Software operator's panel signal (HS1B)	HS1BO	○	○	
F077#2	Software operator's panel signal (HS1C)	HS1CO	○	○	
F077#3	Software operator's panel signal (HS1D)	HS1DO	○	○	
F077#6	Software operator's panel signal (RT)	RTO	○	○	
F078	Software operator's panel signal (*FV0 to *FV7)	*FV0O to *FV7O	○	○	
F079,F080	Software operator's panel signal (*JV0 to *JV15)	*JV0O to *JV15O	○	○	
F081#0,#2,#4,#6	Software operator's panel signal (+J1 to +J4)	+J1O to +J4O	○	○	
F081#1,#3,#5,#7	Software operator's panel signal (-J1 to -J4)	-J1O to -J4O	○	○	

Address	Signal name	Symbol	T series	M series	Reference Item
F082#2	Retrace-in-progress signal	RVSL	–	○	11.15
F090#0	Servo axis abnormal load detected signal	ABTQSV	○	○	2.10
F090#1	First-spindle abnormal load detected signal	ABTSP1	○	○	
F090#2	Second-spindle abnormal load detected signal	ABTSP2	○	○	
F090#3	Abnormal load detection for the third spindle	ABTSP3	○	○	9.15
F091#0	Check mode backward movement signal	MRVMD	○	–	5.3.4
F091#1	Inversion inhibition signal	MNCHG	○	–	
F091#2	Backward movement inhibition signal	MRVSP	○	–	
F092#3	Tool retraction mode signal	TRACT	○	○	5.8
F092#5	Tool return completion signal	TRSPS	○	○	
F093#0	Output signal indicating the expiration of the service life managed by periodic maintenance	LIFOVR	○	○	12.1.22
F093#4 to #7	Servo warning detail signals	SVWRN1 to 4	○	○	18.3
F094	Reference position return end signal	ZP1 to ZP8	○	○	4.1
F096	2nd reference position return end signal	ZP21 to ZP28	○	○	4.5
F098	3rd reference position return end signal	ZP31 to ZP38	○	○	
F100	4th reference position return end signal	ZP41 to ZP48	○	○	
F102	Axis moving signal	MV1 to MV8	○	○	1.2.5
F104	In-position signal	INP1 to INP8	○	○	7.2.6.1
F106	Axis moving direction signal	MVD1 to MVD8	○	○	1.2.5
F108	Mirror image check signal	MMI1 to MMI8	○	○	1.2.6
F110	Controlled axis detach status signal	MDTCH1 to MDTCH8	○	○	1.2.4
F112	Distribution completion signal (PMC axis control)	EADEN1 to EADEN8	○	○	15.1
F114	Torque limit reached signal	TRQL1 to TRQL8	○	○	14.3.4
F116	Floating reference position return end signal	FRP1 to FRP8	○	○	4.6
F118	Synchronous control under way signals	SYN10 to SYN80	○	–	1.8
F118#0 to #6	Synchronous/composite/superimposed control under way signals	SYN10 to SYN70	●	–	1.9
F120	Reference position establishment signal	ZRF1 to ZRF8	○	○	4.1
F122	High-speed skip status signal	HDO0 to HDO7	○	○	14.3.2
F124	Stroke limit reached signals	+OT1 to +OT8	–	○	2.3.2
F126	Stroke limit reached signals	–OT1 to –OT8	–	○	
F129#5	Override 0% signal (PMC axis control)	EOV0	○	○	15.1
F129#7	Control axis selection status signal (PMC axis control)	*EAXSL	○	○	
F130#0	In-position signal (PMC axis control)	EINPA	○	○	
F130#1	Following zero checking signal (PMC axis control)	ECKZA	○	○	
F130#2	Alarm signal (PMC axis control)	EIALA	○	○	
F130#3	Auxiliary function executing signal (PMC axis control)	EDENA	○	○	
F130#4	Axis moving signal (PMC axis control)	EGENA	○	○	

Address	Signal name	Symbol	T series	M series	Reference Item
F130#5	Positive-direction overtravel signal (PMC axis control)	EOTPA	○	○	15.1
F130#6	Negative-direction overtravel signal (PMC axis control)	EOTNA	○	○	
F130#7	Axis control command read completion signal (PMC axis control)	EBSYA	○	○	
F131#0	Auxiliary function strobe signal (PMC axis control)	EMFA	○	○	
F131#1	Bufferful signal (PMC axis control)	EABUFA	○	○	
F132,F142	Auxiliary function code signal (PMC axis control)	EM11A to EM48A	○	○	
F133#0	In-position signal (PMC axis control)	EINPB	○	○	
F133#1	Following zero checking signal (PMC axis control)	ECKZB	○	○	
F133#2	Alarm signal (PMC axis control)	EIALB	○	○	
F133#3	Auxiliary function executing signal (PMC axis control)	EDENB	○	○	
F133#4	Axis moving signal (PMC axis control)	EGENB	○	○	
F133#5	Positive-direction overtravel signal (PMC axis control)	EOTPB	○	○	
F133#6	Negative-direction overtravel signal (PMC axis control)	EOTNB	○	○	
F133#7	Axis control command read completion signal (PMC axis control)	EBSYB	○	○	
F134#0	Auxiliary function strobe signal (PMC axis control)	EMFB	○	○	
F134#1	Bufferful signal (PMC axis control)	EABUFB	○	○	
F135,F145	Auxiliary function code signal (PMC axis control)	EM11B to EM48B	○	○	
F136#0	In-position signal (PMC axis control)	EINPC	○	○	
F136#1	Following zero checking signal (PMC axis control)	ECKZC	○	○	
F136#2	Alarm signal (PMC axis control)	EIALC	○	○	
F136#3	Auxiliary function executing signal (PMC axis control)	EDENC	○	○	
F136#4	Axis moving signal (PMC axis control)	EGENC	○	○	
F136#5	Positive-direction overtravel signal (PMC axis control)	EOTPC	○	○	
F136#6	Negative-direction overtravel signal (PMC axis control)	EOTNC	○	○	
F136#7	Axis control command read completion signal (PMC axis control)	EBSYC	○	○	
F137#0	Auxiliary function strobe signal (PMC axis control)	EMFC	○	○	
F137#1	Buffer full signal (PMC axis control)	EABUFC	○	○	
F138,F148	Auxiliary function code signal (PMC axis control)	EM11C to EM48C	○	○	
F139#0	In-position signal (PMC axis control)	EINPD	○	○	
F139#1	Following zero checking signal (PMC axis control)	ECKZD	○	○	
F139#2	Alarm signal (PMC axis control)	EIALD	○	○	
F139#3	Auxiliary function executing signal (PMC axis control)	EDEND	○	○	
F139#4	Axis moving signal (PMC axis control)	EGEND	○	○	
F139#5	Positive-direction overtravel signal (PMC axis control)	EOTPD	○	○	
F139#6	Negative-direction overtravel signal (PMC axis control)	EOTND	○	○	
F139#7	Axis control command read completion signal (PMC axis control)	EBSYD	○	○	

Address	Signal name	Symbol	T series	M series	Reference Item
F140#0	Auxiliary function strobe signal (PMC axis control)	EMFD	○	○	15.1
F140#1	Buffer full signal (PMC axis control)	EABUFD	○	○	
F141,F151	Auxiliary function code signal (PMC axis control)	EM11D to EM48D	○	○	
F168#0	Alarm signal (serial spindle)	ALMC	○	○	9.2 9.15
F168#1	Speed zero signal (serial spindle)	SSTC	○	○	
F168#2	Speed detection signal (serial spindle)	SDTC	○	○	
F168#3	Speed arrival signal (serial spindle)	SARC	○	○	
F168#4	Load detection signal 1 (serial spindle)	LDT1C	○	○	
F168#5	Load detection signal 2 (serial spindle)	LDT2C	○	○	
F168#6	Torque limit signal (serial spindle)	TLMC	○	○	
F168#7	Orientation completion signal (serial spindle)	ORARC	○	○	
F269#0	Power line switch signal (serial spindle)	CHPC	○	○	
F169#1	Spindle switch completion signal (serial spindle)	CFINC	○	○	
F169#2	Output switch signal (serial spindle)	RCHPC	○	○	
F169#3	Output switch completion signal (serial spindle)	RCFNC	○	○	
F169#4	Slave operation status signal (serial spindle)	SLVSC	○	○	
F169#5	Signal for approximate spindle orientation with a position coder (serial spindle)	PORA2C	○	○	
F169#6	Signal for completion of spindle orientation with a magnetic sensor (serial spindle)	MORA1C	○	○	
F169#7	Signal for approximate spindle orientation with a magnetic sensor (serial spindle)	MORA2C	○	○	
F170#0	Signal indicating the status of the detected one-rotation position coder signal (serial spindle)	PC1DTC	○	○	
F170#1	Incremental method orientation signal (serial spindle)	INCSTC	○	○	
F170#4	Motor activation off status signal (serial spindle)	EXOFC	○	○	
F172#6	Absolute position detector battery voltage zero alarm signal	PBATZ	○	○	1.4.2
F172#7	Absolute position detector battery voltage low alarm signal	PBATL	○	○	
F177#0	Slave I/O Link selection signal	IOLNK	○	○	13.8
F177#1	Slave external read start signal	ERDIO	○	○	
F177#2	Slave read/write stop signal	ESTPIO	○	○	
F177#3	Slave external write start signal	EWTIO	○	○	
F177#4	Slave program selection signal	EPRG	○	○	
F177#5	Slave macro variable selection signal	EVAR	○	○	
F177#6	Slave parameter selection signal	EPARM	○	○	
F177#7	Slave diagnosis selection signal	EDGN	○	○	
F178#0 to #3	Group number output signals	SRLNO0 to SRLNO3	○	○	
F180	Torque limit reach signals for butt-type reference position setting	CLRCH1 to CLRCH8	○	○	4.7
F182	Controlling signal (PMC axis control)	EACNT1 to EACNT8	○	○	15.1

Address	Signal name	Symbol	T series	M series	Reference Item
F197#0 to #3	Flexible synchronization control mode select signal switching accepted signals	MFSYNA to MFSYND	–	○	1.15
F208	EGB mode confirmation signal	EGBM1 to EGBM8	–	○	1.14.4
F264#0 to #7, F265#0	Spindle warning detailed signals	SPWRN1 to 9	○	○	18.4
F266#1	Alarm signal (serial spindle)	ALMD	○	○	9.2 9.15
F266#1	Speed zero signal (serial spindle)	SSTD	○	○	
F266#2	Speed detection signal (serial spindle)	SDTD	○	○	
F266#3	Speed arrival signal (serial spindle)	SARD	○	○	
F266#4	Load detection signal 1 (serial spindle)	LDT1D	○	○	
F266#5	Load detection signal 2 (serial spindle)	LDT2D	○	○	
F266#6	Torque limit signal (serial spindle)	TLMD	○	○	
F266#7	Orientation completion signal (serial spindle)	ORARD	○	○	
F267#0	Power line switch signal (serial spindle)	CHPD	○	○	
F267#1	Spindle switch completion signal (serial spindle)	CFIND	○	○	
F267#2	Output switch signal (serial spindle)	RCHPD	○	○	
F267#3	Output switch completion signal (serial spindle)	RCFND	○	○	
F267#4	Slave operation status signal (serial spindle)	SLVSD	○	○	
F267#5	Signal for approximate spindle orientation with a position coder (serial spindle)	PORA2D	○	○	
F267#6	Signal for completion of spindle orientation with a magnetic sensor (serial spindle)	MORA1D	○	○	
F267#7	Signal for approximate spindle orientation with a magnetic sensor (serial spindle)	MORA2D	○	○	
F268#0	Signal indicating the status of the detected one-rotation position coder signal (serial spindle)	PC1DTD	○	○	
F268#1	Incremental method orientation signal (serial spindle)	INCSTD	○	○	
F268#4	Motor activation off status signal (serial spindle)	EXOFD	○	○	9.15
F274#4	Cs-axis coordinate establishment alarm signal	CSFO1	○	○	9.9.2
F276, F277 F280 to F283 F284 to F287	Output signals for custom macro (Extended signals)	UO016 to UO031 UO200 to UO231 UO300 to UO331	○	○	11.6.1
F298#0 to #7	Trouble forecast signals	TDF1 to 8	○	○	18.1.6

≪ **Symbols** ≫

αi Servo warning interface, 2008

≪ **Numbers** ≫

2nd reference position return/3rd, 4th reference position return, 560

≪ **A** ≫

Abnormal load detection, 443
 About differences among pitch error compensation, straightness compensation, and gradient compensation (for reference purposes), 81
 Absolute position detection, 95
 Acceleration/deceleration control, 943
 Actual speed display, 1605
 Actual spindle speed output (T series), 1064
 Advanced preview control, 798
 AI advanced preview control (M series), 895
 AI contour control/AI nano contour control (M series), 856
 AI high-precision contour control/AI nano high-precision contour control (M series), 897
 Alarm signal, 421
 Alarms and messages, 202
 Angular axis control/arbitrary angular axis control, 244
 Application functions which can use DHCP/DNS, 1955
 Application of DHCP and DNS to FOCAS1/Ethernet function, 1972
 Application which can utilize DNS function, 1955
 Applications which can utilize DHCP function, 1955
 Automatic acceleration/deceleration, 943
 Automatic corner deceleration, 790
 Automatic corner override (M series), 780
 Automatic feedrate control function, 826
 Automatic operation, 601
 Automatic tool length measurement (M series)/automatic tool offset (T series), 1730
 Auxiliary function, 971
 Auxiliary function lock, 985
 Axis control, 1

≪ **B** ≫

B-axis control (T series), 228
 Background editing, 1643
 Backlash compensation, 59
 Balance cut (2-path control for T series), 653
 Bell-shaped acceleration/deceleration after cutting feed interpolation, 956
 Bidirectional pitch error compensation, 68

Butt-type reference position setting, 566

≪ **C** ≫

Canned cycle (M series)/canned cycle for drilling (T series), 1453
 Canned cycle (T series)/multiple repetitive canned cycle (T series), 1466
 Check items related to connection with a backbone, 1974
 Checking and changing of the connection host, 1940
 Checking communication, 1976
 Checking the setting of each parameter, 1975
 Check items related to connection with the hub, 1974
 Chopping function (M series), 248
 Chuck/tailstock barrier (T series), 373
 Circular interpolation, 673
 Clock function, 1520
 CNC ready signal, 353
 Command format, 1138
 Communication parameter input method, 1916
 Composite control, 184
 Configuring a large network, 1903, 1910, 1916
 Connection among spindle, spindle motor, and position coder, 1128
 Constant surface speed control, 1052
 Constant velocity command position control, 1837
 Continuous high-speed skip function, 1751
 Control point compensation of tool length compensation along tool axis, 1285
 Controlled axes, 2
 Controlled axes detach, 15
 Conversational programming with graphic function, 1645
 Coordinate system rotation, 1489
 Corner control, 965
 Cs axis coordinate setup function, 1101
 Cs contour control, 1086
 Custom macro, 1346
 Custom macro variables common to two-path control (T series (two-path control)), 1361
 Cutter compensation, 1270
 Cutter compensation B, C (M series), 1270
 Cutting feedrate clamp, 761
 Cycle start/feed hold, 602
 Cylindrical interpolation, 704
 Cylindrical interpolation cutting point compensation (M series), 707

≪ **D** ≫

Data input/output functions based on the I/O Link, 1697
 Decimal point programming/pocket calculator type decimal point programming, 1322
 Definition of warning, caution, and note, 203

DHCP/DNS functions, 1950
 Direct operation by PMC or OPEN CNC, 1870
 Direction-sensitive high-speed position switch, 39
 Display data on the diagnosis screen, 1134
 Display of hardware and software configuration, 1532
 Display/set, 1520
 Display/set/edit, 1519
 Displaying alarm history, 1527
 Displaying operating monitor, 1549
 Displaying operation history, 1521
 DNC operation, 655
 DNC operation by a PC connected to the HSSB PORT2, 1871
 DNC operation by the PMC or OPEN CNC (PC with HSSB connection), 1870
 DNC1 interface, 1671
 DNC1/Ethernet function, 1892
 DNC2 interface, 1680
 Dry run, 615

«E»

Edit, 1635
 Electric gear box (M series), 279
 Electronic gear box 2 pair (M series), 315
 EMB_ETH FACTOLINK log screen, 1980
 EMB_ETH FOCAS1/Ether log screen, 1980
 EMB_ETH FTP transfer log screen, 1980
 EMB_ETH MASTER CTRL log screen, 1979
 Embedded Ethernet and PCMCIA Ethernet, 1889
 Embedded Ethernet error message screen, 1942
 Embedded Ethernet function, 1888
 Embedded Ethernet maintenance screen, 1944
 Embedded Ethernet operations, 1926
 Embedded Macro, 1363
 Embedded macro for milling (M series), 1376
 Embedded measurement macros (M series), 1422
 Emergency stop, 350
 Encrypting programs, 1648
 Entering compensation values, 1758
 Erase screen display/automatic erase screen display, 1568
 Error compensation, 49
 Error detect (T series), 969
 Error messages, 1979
 Ethernet parameter screen, 1953
 Exact stop/exact stop mode/tapping mode/cutting mode (M series), 651
 Example of DHCP server settings on Windows2000 server, 1957
 Example of DNS server settings on Windows2000 server, 1965
 Example of settings, 1956
 Examples of applications, 210

Expanded external workpiece number search, 1854
 Exponential interpolation (M series), 742
 Extended bidirectional pitch error compensation, 77
 Extended function of the linear scale with absolute addressing reference marks, 593
 External data input, 1839
 External deceleration, 784
 External I/O device control, 1681
 External key input, 1864
 External motion function (M series), 1464
 External operator message logging and display, 1566
 External program input, 1692
 External touch panel interface, 1575
 External workpiece number search, 1851

«F»

FACTOLINK function, 1890, 1926
 FACTOLINK parameter setting screen, 1897
 FANUC SERVO MOTOR β series I/O link option manual handle interface (peripheral device control), 1880
 FANUC two-byte character code table, 1629
 Feed forward in rapid traverse, 970
 Feed per minute, 763
 Feed per revolution/manual feed per revolution, 766
 Feed stop function, 786
 Feedrate clamping by arc radius (M series), 787
 Feedrate control, 758
 Feedrate control method, 905
 Feedrate control/acceleration and deceleration control, 757
 Feedrate inverse time specification (M series), 771
 Feedrate override, 775
 Fine torque sensing, 1588
 Flexible synchronization control (M series), 337
 Floating reference position return, 563
 Flow of action, 1972
 FOCAS1/Ethernet function, 1891
 FOCAS1/Ethernet parameter setting screen, 1904
 Follow-up, 23
 FSSB setting, 97
 FTP file transfer function, 1894, 1927
 FTP file transfer parameter setting screen, 1911
 Functional differences between the embedded Ethernet function and the Ethernet function based on the option board, 1894

«G»

G code system (T series), 1325
 General purpose retract, 345
 Glossary for Ethernet, 1981
 Gradient compensation, 65

Graphic display/dynamic graphic display/background graphic, 1540

«H»

Handle-synchronous feed, 509, 525
 Helical interpolation, 696
 Helical interpolation B (M series), 747
 Help function, 1526
 High speed cycle cutting, 1339
 High-precision contour control by RISC (M series), 810
 High-speed cycle machining retracting, 1507
 High-speed cycle machining skip function, 1514
 High-speed linear interpolation (M series), 934
 High-speed M/S/T/B interface, 991
 High-speed position switch, 32
 High-speed signal, 1740
 Hobbing function (T series)/function for hobbing machine (M series), 262
 Host file deletion, 1930
 Host file list display, 1927
 Host file search, 1930
 Hypothetical axis interpolation, 746

«I»

In-position check, 965
 In-position check independently of feed/rapid traverse, 967
 Inch/metric conversion, 1334
 Increment system, 7
 Index table indexing function (M series), 1476
 Input of measured workpiece origin offsets, 1780
 Input of offset value measured A (T series), 1758
 Input of tool offset value measured B (T series), 1760
 Input/output of data, 1655
 Input/output of various types of data, 1934
 Interface between CNC and PMC, 2031
 Interface with the power mate CNC, 1879
 Interfaces related to Series 20i MACRO, 2012
 Interpolation function, 666
 Interpolation type pitch error compensation, 79
 Interpolation type straightness compensation, 82
 Interruption type custom macro, 1358
 Involute interpolation (M series), 698

«J»

Jog feed/incremental feed, 461

«L»

Linear acceleration/deceleration after cutting feed interpolation, 952
 Linear acceleration/deceleration before cutting feed interpolation, 959
 Linear interpolation, 670
 Linear interpolation (G28, G30, G53), 753
 Linear scale I/F with absolute address referenced mark (A/B phase)/linear scale with distance-coded reference marks (serial), 573
 List of addresses, 2032
 List of functions, 1890
 List of signals, 2161
 List of signals (in order of addresses), 2204
 List of signals (in order of functions), 2161
 List of signals (in order of symbols), 2184
 Look-ahead acceleration/deceleration before interpolation, 813, 899
 Look-ahead bell-shaped acceleration/deceleration before interpolation time constant change function (M series), 937

«M»

M code group check function, 997
 M29 and G84 (G74) are specified in the same block, 1156
 Machine alarm diagnosis, 1999
 Machine coordinate system, 118
 Machine lock, 612
 Machining condition selecting, 1614
 Macro compiler/executer, 1499
 Making guidance tables, 2000
 Manual absolute on/off, 636
 Manual handle feed, 470
 Manual handle interruption, 478
 Manual handle retrace (T series), 621
 Manual intervention and return, 658
 Manual linear/circular interpolation, 492
 Manual numeric command, 518
 Manual operation, 460
 Manual reference position return, 533
 Manual rigid tapping (M Series), 515
 Measurement, 1728
 Memory protection key, 1637
 Mirror image, 20
 Mirror image for double turrets (T series), 1474
 Miscellaneous function/2nd auxiliary function, 972
 Mode selection, 429
 Multi-language display, 1563
 Multi-spindle control, 1109
 Multi-step skip, 1744
 Multiple M commands in a single block, 987

«N»

Name of axes, 5

NC program output, 1932
 No. of registered programs, 1636
 Normal direction control (M series), 736
 Notes on interface with the PMC, 1148
 Notes on using the FACTOLINK function for the first time, 1896
 Notes on using the FOCAS1/Ethernet function for the first time, 1903
 Notes on using the FTP file transfer function for the first time, 1910
 NURBS interpolation (M series), 751

«O»

One touch macro call, 1872
 One-digit F code feed (M series), 768
 Optional block skip/addition of optional block skip, 639
 Other functions, 1628
 Outputting the movement state of an axis, 18
 Override, 772
 Override cancel, 779
 Overtravel check, 355
 Overtravel signal, 355

«P»

Parameter set supporting screen, 1606
 Parameter setting of the FACTOLINK function, 1896
 Parameter setting of the FOCAS1/Ethernet function, 1903
 Parameter setting of the FTP file transfer function, 1910
 Parameters, 1900, 1914, 1952
 Parameters related to servo, 90
 Part program storage length, 1635
 Password function, 1640
 Path selection/display of optional path names (two-path control), 437
 Periodic maintenance screen, 1578
 Playback, 1644
 PMC axis control, 1786
 PMC Axis control expansion, 1833
 PMC control function, 1785
 Polar coordinate interpolation, 701
 Polygonal turning, 713
 Polygonal turning (T series), 712
 Polygonal turning with two spindles, 718
 Position display neglect, 1533
 Position switch, 27
 Positioning, 667
 Positioning by optimal acceleration, 852
 Preparations for operation, 349
 Program command, 1321

Program configuration, 1331
 Program copy between two paths, 1645
 Program restart, 644

«R»

Rapid traverse bell-shaped acceleration/deceleration, 949
 Rapid traverse block overlap, 947
 Rapid traverse override, 772
 Rapid traverse rate, 758
 Reader/puncher interface, 1656
 Ready signals for serial spindle operation, 1237
 Reference position establishment, 532
 Reference position return, 557
 Reference position shift, 554
 Remote buffer, 1670
 Remote diagnosis, 1564
 Reset and rewind, 607
 Retrace (M series), 1495
 Retraction for rigid tapping (M series), 659
 Rigid tapping, 1126
 Rigid tapping specification, 1133
 Rigid-tapping bell-sharped acceleration/deceleration (M series), 1198
 RISC processor operation (AI high-precision contour control/AI Nano high-precision contour control/tool length compensation along the tool axis/three-dimensional cutter compensation/tool tip control/three-dimensional circular interpolation) (M Series), 922
 Rotary axis roll over, 127
 Rotary table dynamic fixture offset (M series), 130
 Rotation area interference check, 388
 Run hour and parts count display, 1534

«S»

Scaling (M Series), 1485
 Screen hard copy function, 1721
 Second feedrate override, 778
 Self-diagnosis, 1531
 Sequence number comparison and stop, 643
 Series 16i/18i/160i/180i/160is/180is list of address (one-path control), 2032
 Series 16i/18i/160i/180i/160is/180is list of address (two-path control), 2060
 Series 20i address list, 2142
 Series 21i/210i/210is address list, 2114
 Servo off (mechanical handle), 25
 Servo tuning screen, 1528
 Servo/spindle motor speed detection, 454
 Setting each axis, 5
 Setting of a PC, 1973
 Setting the embedded Ethernet function, 1896

Setting the reference position without dogs, 546
 Settings, 1952
 Settings of CNC, 1973
 Settings related to servo-controlled axes, 90
 Settings related with coordinate systems, 118
 Signals for the rigid tapping function, 1142
 Signals related to gear switching, 1144
 Signals related to S code output, 1143
 Signals related to second spindle/third spindle rigid tapping, 1146
 Signals used by machining guidance function (20i-F/T), 2013
 Signals used for polygon limit machining (20i-F), 2026
 Simple electric gear box (G80, G81), 279
 Simple spindle synchronous control, 1225
 Simple synchronous control, 139
 Simultaneous input and output operations (M series), 1689
 Single block, 618
 Single direction positioning, 689
 Skip function, 1737
 Skip function for EGB axis (M series), 1754
 Small hole peck drilling cycle (M series), 1500
 Smooth interpolation (M series), 744
 Software operator's panel, 1552
 Specifying G84 (G74) for rigid tapping by parameters, 1160
 Specifying the rotation axis, 11
 Spindle electronic gear box (M series), 291
 Spindle orientation, 1207
 Spindle output control by the PMC, 1856
 Spindle output switching, 1211
 Spindle positioning (T series), 1065
 Spindle serial output/spindle analog output, 1003
 Spindle setting and tuning screen, 1528
 Spindle speed control, 1011
 Spindle speed control for two-path lathe, 1040
 Spindle speed fluctuation detection, 1059
 Spindle speed function, 1001
 Spindle speed function (S code output), 1002
 Spindle synchronous control, 1203
 Spiral interpolation, conical interpolation (M series), 748
 Stamping the machining time, 1551
 Start lock/interlock, 423
 Status output signal, 439
 Stop position setting for JOG feed, 523
 Stored pitch error compensation, 49
 Stored stroke check 1, 358
 Stored stroke limit 2, 3, 365
 Straightness compensation, 61
 Stroke limit check before move, 384
 Superimposed control, 187
 Switching between the embedded Ethernet devices, 1924

Synchronous control, 177
 Synchronous control (T series), 164
 Synchronous control and composite control (T series (two-path control)), 174

« T »

Tandem control, 155
 Tentative absolute coordinate setting (M series), 115
 Testing a program, 612
 Thread cutting, 680
 Thread cutting cycle retract (T series), 687
 Three-dimensional circular interpolation (M series), 755
 Three-dimensional coordinate conversion, 1492
 Three-dimensional cutter compensation (M series), 1296
 Three/four-spindle serial output, 1213
 Timing charts for rigid tapping specification, 1151
 Timing to cancel rigid tapping mode, 1164
 Tool axis direction handle feed function, 481
 Tool axis direction handle feed function/tool axis direction handle feed function B (M series), 481
 Tool axis direction tool length compensation (M series), 1280
 Tool axis perpendicular direction handle feed function, 486
 Tool center point control (M series), 1306
 Tool compensation value/tool compensation number/tool compensation memory, 1243
 Tool function, 1240
 Tool functions, 1239
 Tool length measurement (M series), 1729
 Tool length/workpiece origin measurement B (M series), 1781
 Tool life arrival notice signal (M series), 1268
 Tool life management, 1259
 Tool life management B (M series), 1268
 Tool nose radius compensation (T series), 1276
 Tool offset pairs (400 pairs) and tool offset pairs (999 pairs) (T series), 1251
 Tool post interference check (T series (two-path control)), 379
 Tool retraction and return, 647
 Torque limit skip, 1748
 Touch panel, 1571
 Trouble diagnosis, 1983, 1984
 Trouble diagnosis graphic screen, 1994
 Trouble diagnosis guidance screen, 1986
 Trouble diagnosis monitor screen, 1988
 Trouble diagnosis parameter screen, 1992
 Trouble forecast level setting screen (only for servo axis), 1996
 Troubleshooting, 224, 1974

« U »

Using the DNC1/Ethernet function on a small network, 1909
 Using the FACTOLINK function on a small network, 1902

Using the FOCAS1/Ethernet function on a small network, 1908

Using the FTP file transfer function on a small network, 1915

« V »

VRDY OFF alarm ignore signal, 441

« W »

Waiting M code (two-path control), 995

Warning Interface for the α i Spindle, 2010

Waveform diagnosis display, 1529

When M29 is specified before G84 (G74), 1152

Workpiece coordinate system/addition of workpiece coordinate system pair, 120

Revision Record

FANUC Series 16i/160i/160is/18i/180i/180is/21i/210i/210is-MODEL B CONNECTION MANUAL (FUNCTION) (B-63523EN-1)

03	Sep., 2004	<ul style="list-style-type: none"> ● Addition of Series 20i-MODEL B ● Addition of signals ● Addition of parameters ● Addition of functions 				
02	Nov., 2001	<ul style="list-style-type: none"> ● Addition of Series 160is/180is/210is-MODEL B ● Addition of Series 18i/180i/180is-MB5 ● Addition of signals ● Addition of parameters ● Addition of functions 				
01	June., 2001	_____				
Edition	Date	Contents	Edition	Date	Contents	

